

APPENDIX
CHAPTER ILHR 20

State of Wisconsin Department of Industry, Labor & Human Relations Division of Safety & Buildings Box 7263 Madison, WI 53707 Wisconsin Statutes 101.63, 101.33		WISCONSIN UNIFORM BUILDING PERMIT APPLICATION <small>(See instructions on back)</small>		APPLICATION NO.
PERMIT REQUESTED <input type="checkbox"/> STRUCTURE <input type="checkbox"/> HVAC <input type="checkbox"/> ELEC <input type="checkbox"/> PLUMBING		PARCEL NO.		
Owner's Name _____ Mailing Address _____ Telephone _____		Contractor's Name _____ Mailing Address _____ Telephone _____		
PROJECT LOCATION Building Address _____		Subdivision Name _____ Lot No. _____ Block No. _____		
Zoning District _____ Lot Area _____ Sq. Ft.		Setbacks: Front _____ ft. Rear _____ ft. Left _____ ft. Right _____ ft.		
1. PROJECT <input type="checkbox"/> New <input type="checkbox"/> Addition <input type="checkbox"/> Extension <input type="checkbox"/> Repair <input type="checkbox"/> Garage <input type="checkbox"/> Raze <input type="checkbox"/> Attached <input type="checkbox"/> Move <input type="checkbox"/> Detached <input type="checkbox"/> Foundation <input type="checkbox"/> Water plan no. (if applicable)	3. TYPE <input type="checkbox"/> Single Family <input type="checkbox"/> Two Family <input type="checkbox"/> Other	6. ELECTRICAL Entrance Panel _____ amp Service: _____ <input type="checkbox"/> In-ground <input type="checkbox"/> Outside	8. HVAC EQUIPMENT <input type="checkbox"/> Forced Air Furnace <input type="checkbox"/> Radiant Baseboard or Panel <input type="checkbox"/> Heat Pump <input type="checkbox"/> Boiler <input type="checkbox"/> Central Air Conditioning <input type="checkbox"/> Other	12. ENERGY SOURCE Fuel: _____ LP Gas _____ Nat. Gas _____ Fuel Oil _____ Electric _____ Wood _____ Solar _____ Coal _____ Other _____
2. AREA Basements _____ Sq. Ft. Living Area _____ Sq. Ft. Garage _____ Sq. Ft.	4. CONST. TYPE <input type="checkbox"/> Site constructed <input type="checkbox"/> Manufactured	7. FOUNDATION <input type="checkbox"/> Concrete <input type="checkbox"/> Masonry <input type="checkbox"/> Treated Wood <input type="checkbox"/> Other	10. PLUMBING Sewer _____ <input type="checkbox"/> Municipal <input type="checkbox"/> Septic Permit No. _____	13. HEAT LOSS (Calculated) Envelope _____ BTU/HR Infiltration _____ BTU/HR
		5. STORIES <input type="checkbox"/> 1 Story <input type="checkbox"/> 2 Story <input type="checkbox"/> Other	9. USE <input type="checkbox"/> Residential <input type="checkbox"/> Commercial <input type="checkbox"/> Other	14. ESTIMATED COST \$ _____
The applicant agrees to comply with the Wisconsin Uniform Building Code and other Municipal Ordinances and with the conditions of this permit; understands that the issuance of the permit creates no legal liability, express or implied, on the Department or Municipality; and certifies that all the above information is accurate.				
SIGNATURE OF APPLICANT _____		DATE _____		
CONDITIONS OF APPROVAL This permit is issued pursuant to the following conditions. Failure to comply may result in suspension or revocation of this permit or other penalty.				
ISSUING JURISDICTION		VILLAGES CITY TOWN COUNTY ESTATE		
NAME _____		MUNIC. NO. _____		
FEES: Plan Review _____ \$ Inspection _____ \$ Wis. Permit Seal _____ \$ Other _____ \$ TOTAL _____ \$	PERMIT (S) ISSUED: _____ <input type="checkbox"/> Construction <input type="checkbox"/> HVAC <input type="checkbox"/> Electrical <input type="checkbox"/> Plumbing <input type="checkbox"/> Other	WIS. UNIFORM PERMIT REAL NO. _____	PERMIT ISSUED BY: _____ NAME _____ DATE _____ CERT. NO. _____	
<small>DILHR 99D 6873 (R-1-1987)</small>		<small>WHITE - Issuing Jurisdiction YELLOW - DILHR GREEN - Inspector PINK - Owner/Agent</small>		

Site Info

SUBDIVISION _____
 LOT NO. _____ BLOCK NO. _____
 ZONING DISTRICT _____
 _____X____Y____SEC____T____N____E or W
 SETBACKS:
 FRONT YARD _____ feet
 REAR YARD _____ feet
 LEFT YARD _____ feet
 RIGHT YARD _____ feet

WISCONSIN UNIFORM BUILDING PERMIT

Inspection

PHASE	RHG	FNL
FOUNDATION		
CONSTRUCTION		
INSULATION		
PLUMBING		
HEAT/VENT/AC		
ELECTRICAL		
OCCUPANCY		

const; hvac; elec; plumb;

NOTICE OF NONCOMPLIANCE

This issuing jurisdiction shall notify the applicant in writing of any violations to be corrected. All cited violations shall be corrected within 30 days after notification, unless extension of time is granted.

Issued to

OWNER (AGENT)
 BUILDING SITE ADDRESS
 CITY, VILLAGE TOWN, COUNTY

Issued by

MUNICIPALITY OR AUTHORIZED AGENCY	
PERSON ISSUING	CERT. NO.
DATE ISSUED	TELEPHONE NUMBER

affix uniform permit seal here (where applicable)

Keep this card posted until final inspection has been made. Inspections shall be arranged 48 hrs. in advance. Work shall not proceed until the inspector has approved the various stages of construction or the 48 hr. period since notification has elapsed. This permit will expire 24 months after the date of issuance if construction has not commenced.

DUW-620-5824

Register, February, 1985, No. 350

APPENDIX

CHAPTER ILHR 21

FASTENER SCHEDULE TABLE

Description of Building Materials/Connection	Number and Type of Fastener ^{1 2 3 4}
Joist to sill or girder, toe nail	2-16d, 3-8d
Bridging to joist, toe nail each end	2-8d
1" x 6" subfloor or less to each joist, face nail	2-8d or 2 staples, 1 3/4"
Wider than 1" x 6" subfloor to each joist, face nail	3-8d or 4 staples, 1 3/4"
2" subfloor to joist or girder, blind and face nail	2-16d
Sole plate to joist or blocking, face nail	16d at 16" o.c.
Top or sole plate to stud, end nail	2-16d
Stud to sole plate, toe nail	4-8d or 3-16d
Doubled studs, face nail	16d at 24" o.c.
Doubled top plates, face nail	16d at 16" o.c.
Top plates, laps and intersections, face nail	2-16d
Continuous header, two pieces	16d at 16" o.c. along each edge
Ceiling joists to plate, toe nail	2-16d, 3-8d
Continuous header to stud, toe nail	4-8d
Ceiling joist, laps over partitions, face nail	3-16d
Ceiling joist to parallel rafters, face nail	3-16d
Rafter to plate, toe nail	2-16d, 3-8d
1" brace to each stud and plate, face nail	2-8d or 2 staples, 1 3/4"
1" x 6" sheathing to each bearing, face nail	2-8d or 2 staples, 1 3/4"
1" x 8" sheathing to each bearing, face nail	2-8d or 3 staples, 1 3/4"
Wider than 1" x 8" sheathing to each bearing, face nail	3-8d or 4 staples, 1 3/4"
Built-up corner studs	16d at 30" o.c., 16d at 24" o.c.
Built-up girder and beams	20d at 32" o.c. at top and bottom and staggered 2-20d at ends and at each splice
2-inch planks	2-16d at each bearing
Roof rafters to ridge, valley or hip rafters, toe nail	4-16d
Roof rafters to ridge, valley or hip rafters, face nail	3-16d
Collar ties to rafters, face nail	3-8d
Plywood subfloor, roof and wall sheathing (to framing) ⁵	
1/2-inch to 5/16-inch	6d ⁵ or staple
3/8-inch to 1/2-inch	8d smooth or common, 6d deformed, or staple
1/2-inch to 1-inch	8d ⁵
1 1/4-inch to 1 1/2-inch	10d smooth or common, or 8d deformed
Fiberboard sheathing ⁷	
1/2-inch	6d common or staple, 1 1/2" long or roofing nail ¹¹
25/32-inch	8d common or staple, 1 1/2" long or roofing nail ¹¹
Gypsum sheathing, 1/2" ⁸	1 1/2" galvanized roofing nail, or 6d common, or staple
Particleboard wall sheathing (to framing) ⁶	
1/2-inch to 3/8-inch	6d common
3/8-inch to 1/2-inch	8d common or staple
Insulated sheathing	11-gauge roofing nails, 6d, 8d, or staple
Combination subfloor underlayment (to framing) ⁶	
1/2-inch and less	6d deformed
3/8-inch to 1-inch	8d deformed
1 1/4-inch to 1 1/2-inch	10d smooth ⁹ or common or 8d deformed ⁹
Panel siding (to framing) ¹⁰	
1/2-inch or less	6d
3/4-inch	8d

- ¹All nails are smooth-common, box or deformed shank except where otherwise stated.
- ²Nail is a general description and may be T-head, modified round head or round head.
- ³Staples are 16-gauge wire and have a minimum 7/16-inch o.d. crown width.
- ⁴Common or box nails may be used except where otherwise stated.
- ⁵Common or deformed shank.
- ⁶Nails spaced at 6 inches on center at edges, 12 inches at intermediate supports (10 inches at intermediate supports for floors), except 6 inches at all supports where spans are 48 inches or more.
- ⁷Nails spaced at 3 inches on center at edges, 6 inches at intermediate supports.
- ⁸Nails spaced at 4 inches on center at edges, 8 inches at intermediate supports.
- ⁹Nails spaced at 6 inches on center at edges and at intermediate supports.
- ¹⁰Corrosion-resistant siding and casing nails.
- ¹¹Galvanized roofing nails with 7/16-inch diameter head and 1½-inch length for ¼-inch sheathing and 1¾-inch for 25/32-inch sheathing.

SPAN TABLES FOR JOISTS AND RAFTERS
(Recommended by National Forest Products Association)

EXPLANATION OF TABLES

These span tables for joists and rafters are calculated on the basis of a series of modulus of elasticity (E) and fiber bending stress (F_b) values. The range of values in the tables provides allowable spans for all species and grades of nominal 2-inch framing lumber customarily used in construction.

Tables J-1 through J-6 list spans for floor and ceiling joists used over a single span with calculations based on E and the required F_b values shown.

Tables R-2 through R-15 list spans for rafters used over a single span with calculations based on F_b and the required E values shown.

Tables TSJ-1 and TSJ-2 list spans for floor joists continuous over two equal spans with calculations based on E and the required F_b values shown.

Applicable design criteria for each condition of use appear at the top of each table. While these criteria are directed principally to residential construction, they are suitable for other occupancies having similar conditions of loading. Tabulated spans for rafters also apply to other types of occupancy, since the occupancy has little bearing on roof loading.

LUMBER SIZES

Tabulated spans apply to surfaced (S4S) lumber having dimensions which conform to the American Softwood Lumber Standard, PS 20-70. These sizes are as follows:

Reference	Dressed Size (inches)	
	Surfaced Dry	Surfaced Green
2 x 4	1½ x 3½	1-9/16 x 3-9/16
2 x 6	1½ x 5½	1-9/16 x 5½
2 x 8	1½ x 7½	1-9/16 x 7½

2 x 10	1½ x 9¼	1-9/16 x 9½
2 x 12	1½ x 11¼	1-9/16 x 11½

MOISTURE CONTENT

The listed dry and green sizes are related at 19% maximum moisture content. Tabulated spans are calculated on the basis of the dry sizes and are also applicable to the corresponding green sizes. The spans in these tables are intended for use in covered structures or where moisture content in use does not exceed 19%.

SPAN MEASUREMENT

Tabulated spans are the clear distance between supports. For sloping rafters, the span is measured along the horizontal projection.

LUMBER DESIGN VALUES

Use of these span tables requires reference to the applicable design values for the various species and grades of lumber. "Design Values for Joists and Rafters", a supplement to these span tables, provide such values in convenient-to-use form. Modulus of elasticity (E) and fiber bending stress (F_b) values therein are based on the National Design Specification for Wood Construction (formerly National Design Specification for Stress Grade Lumber and Its Fastenings) and incorporate adjustments appropriate for repetitive-member use under various durations of load.

Repetitive-member use is that condition where framing members such as joists, rafters, studs, planks, decking or similar members are spaced not more than 24 inches, are not less than 3 in number and are joined by floor, roof or other load-distributing elements adequate to support the design load. Design values in bending (F_b) for such use are 15% greater than for single-member use.

The "Joists" column in the design value tables provide values for bending for repetitive-member use under normal conditions. The "Rafters" column if the design value tables provide values for bending for repetitive-member use adjusted for snow-loading.

ROOF LOADS

Rafter spans are tabulated for the most common roof loads. For roof loads intermediate between those tabulated, straight line interpolation may be used.

LUMBER IDENTIFICATION

When used with the tabulated spans in these tables, lumber should be identified by the grademark of an agency recognized as being competent by the Board of Review of the American Lumber Standards Committee or the Canadian Lumber Standards Administrative Board.

USE OF THE SPAN TABLES

Spans for floor and ceiling joists are calculated on the basis of the modulus of elasticity (E) with the required fiber bending stress (F_b) listed below each span. Spans for rafters are calculated on the basis of fiber bending stress (F_b) with the required modulus of elasticity (E) listed below each span. Use of the tables is illustrated in the examples which follow.

Example 1. Floor joists. Assume a required span of 12'-9", a live load of 40 psf and joists spaced 16 inches on centers. Table J-1 shows that a grade of 2 x 8 having an E value of 1,600,000 psi and an F_b value of 1250 psi would have a span of 12'-10", which satisfies the condition.

Example 2. Rafters. Assume a horizontal projection span of 13'-0", a live load of 30 psf, dead load of 15 psf and rafters spaced 16 inches on centers. Table R-2 shows that a 2x8 having an F_b value of 1300 psi and an E value of 1,000,000 psi would have a span of 13'-3" of horizontal projection.

Since many combinations of size, spacing, E and F_b values are possible, it is recommended that the users examine the tables to determine which combination fits their particular case most effectively.

TABLE J-1
FLOOR JOISTS

40 Lbs. Per Sq. Ft. Live Load
(All rooms except those used for sleeping areas and attic floors.)

DESIGN CRITERIA:
Deflection - For 40 lbs. per sq. ft. live load, limited to span in inches divided by 360.
Strength - Live Load of 40 lbs. per sq. ft. plus dead load of 10 lbs. per sq. ft. determines the required floor stress value.

JOIST SIZE SPACING (IN)	Modulus of Elasticity, "E", in 1,000,000 psi																			
	0.4	0.5	0.6	0.7	0.8	0.9	1.0	1.1	1.2	1.3	1.4	1.5	1.6	1.7	1.8	1.9	2.0	2.2	2.4	
12.0	6-9	7-3	7-9	8-2	8-6	8-10	9-2	9-6	9-9	10-0	10-3	10-6	10-9	10-11	11-2	11-4	11-7	11-11	12-3	
	4-6	7-0	7-5	7-9	8-2	8-6	8-9	9-1	9-4	9-7	9-10	10-0	10-3	10-6	10-8	10-10	11-1	11-5	11-9	
	4-7	5-9	6-20	6-50	6-80	7-10	7-40	7-70	7-90	8-0	8-1	8-4	8-6	8-9	9-11	10-2	10-4	10-10	11-2	
	5-9	6-3	6-7	7-0	7-3	7-7	7-10	8-1	8-4	8-7	8-9	9-0	9-2	9-4	9-6	9-8	9-10	10-2	10-6	10-10
	5-4	5-9	6-2	6-6	6-9	7-0	7-3	7-6	7-9	7-11	8-2	8-4	8-6	8-8	8-10	8-10	8-10	9-2	9-6	9-9
13.7	4-7	5-0	5-3	5-6	5-9	6-2	6-5	6-7	6-10	7-0	7-3	7-5	7-7	7-9	7-11	8-0	8-2	8-4	8-7	8-10
	4-6	5-0	5-3	5-6	5-9	6-2	6-5	6-7	6-10	7-0	7-3	7-5	7-7	7-9	7-11	8-0	8-2	8-4	8-7	8-10
	4-6	5-0	5-3	5-6	5-9	6-2	6-5	6-7	6-10	7-0	7-3	7-5	7-7	7-9	7-11	8-0	8-2	8-4	8-7	8-10
	4-6	5-0	5-3	5-6	5-9	6-2	6-5	6-7	6-10	7-0	7-3	7-5	7-7	7-9	7-11	8-0	8-2	8-4	8-7	8-10
	4-6	5-0	5-3	5-6	5-9	6-2	6-5	6-7	6-10	7-0	7-3	7-5	7-7	7-9	7-11	8-0	8-2	8-4	8-7	8-10
16.0	4-6	5-0	5-3	5-6	5-9	6-2	6-5	6-7	6-10	7-0	7-3	7-5	7-7	7-9	7-11	8-0	8-2	8-4	8-7	8-10
	4-6	5-0	5-3	5-6	5-9	6-2	6-5	6-7	6-10	7-0	7-3	7-5	7-7	7-9	7-11	8-0	8-2	8-4	8-7	8-10
	4-6	5-0	5-3	5-6	5-9	6-2	6-5	6-7	6-10	7-0	7-3	7-5	7-7	7-9	7-11	8-0	8-2	8-4	8-7	8-10
	4-6	5-0	5-3	5-6	5-9	6-2	6-5	6-7	6-10	7-0	7-3	7-5	7-7	7-9	7-11	8-0	8-2	8-4	8-7	8-10
	4-6	5-0	5-3	5-6	5-9	6-2	6-5	6-7	6-10	7-0	7-3	7-5	7-7	7-9	7-11	8-0	8-2	8-4	8-7	8-10
19.2	4-6	5-0	5-3	5-6	5-9	6-2	6-5	6-7	6-10	7-0	7-3	7-5	7-7	7-9	7-11	8-0	8-2	8-4	8-7	8-10
	4-6	5-0	5-3	5-6	5-9	6-2	6-5	6-7	6-10	7-0	7-3	7-5	7-7	7-9	7-11	8-0	8-2	8-4	8-7	8-10
	4-6	5-0	5-3	5-6	5-9	6-2	6-5	6-7	6-10	7-0	7-3	7-5	7-7	7-9	7-11	8-0	8-2	8-4	8-7	8-10
	4-6	5-0	5-3	5-6	5-9	6-2	6-5	6-7	6-10	7-0	7-3	7-5	7-7	7-9	7-11	8-0	8-2	8-4	8-7	8-10
	4-6	5-0	5-3	5-6	5-9	6-2	6-5	6-7	6-10	7-0	7-3	7-5	7-7	7-9	7-11	8-0	8-2	8-4	8-7	8-10
24.0	4-6	5-0	5-3	5-6	5-9	6-2	6-5	6-7	6-10	7-0	7-3	7-5	7-7	7-9	7-11	8-0	8-2	8-4	8-7	8-10
	4-6	5-0	5-3	5-6	5-9	6-2	6-5	6-7	6-10	7-0	7-3	7-5	7-7	7-9	7-11	8-0	8-2	8-4	8-7	8-10
	4-6	5-0	5-3	5-6	5-9	6-2	6-5	6-7	6-10	7-0	7-3	7-5	7-7	7-9	7-11	8-0	8-2	8-4	8-7	8-10
	4-6	5-0	5-3	5-6	5-9	6-2	6-5	6-7	6-10	7-0	7-3	7-5	7-7	7-9	7-11	8-0	8-2	8-4	8-7	8-10
	4-6	5-0	5-3	5-6	5-9	6-2	6-5	6-7	6-10	7-0	7-3	7-5	7-7	7-9	7-11	8-0	8-2	8-4	8-7	8-10
32.0	4-6	5-0	5-3	5-6	5-9	6-2	6-5	6-7	6-10	7-0	7-3	7-5	7-7	7-9	7-11	8-0	8-2	8-4	8-7	8-10
	4-6	5-0	5-3	5-6	5-9	6-2	6-5	6-7	6-10	7-0	7-3	7-5	7-7	7-9	7-11	8-0	8-2	8-4	8-7	8-10
	4-6	5-0	5-3	5-6	5-9	6-2	6-5	6-7	6-10	7-0	7-3	7-5	7-7	7-9	7-11	8-0	8-2	8-4	8-7	8-10
	4-6	5-0	5-3	5-6	5-9	6-2	6-5	6-7	6-10	7-0	7-3	7-5	7-7	7-9	7-11	8-0	8-2	8-4	8-7	8-10
	4-6	5-0	5-3	5-6	5-9	6-2	6-5	6-7	6-10	7-0	7-3	7-5	7-7	7-9	7-11	8-0	8-2	8-4	8-7	8-10

	11.4	12.3	13.0	13.8	14.4	14.11	15.5	15.11	16.5	16.10	17.3	17.8	18.0	18.5	18.9	18.1	19.5	20.1	20.8
	450	520	590	660	720	780	830	890	940	990	1040	1090	1140	1190	1230	1280	1320	1410	1490
	10.10	11.8	12.5	13.1	13.8	14.3	14.8	15.3	15.8	16.1	16.5	16.11	17.3	17.7	17.11	18.3	18.7	19.2	19.9
	470	540	620	690	750	810	870	930	980	1040	1090	1140	1190	1240	1280	1340	1390	1470	1560
2x10	10.4	11.1	11.10	12.5	13.0	13.6	14.0	14.6	14.11	15.3	15.8	16.0	16.5	16.9	17.3	17.4	17.8	18.3	18.9
	500	580	650	720	790	850	920	980	1040	1090	1150	1200	1250	1310	1360	1410	1460	1580	1640
	9.9	10.6	11.1	11.8	12.3	12.9	13.2	13.7	14.0	14.5	14.9	15.1	15.5	15.9	16.3	16.4	16.7	17.2	17.8
	530	610	690	770	840	910	970	1040	1100	1160	1220	1280	1330	1390	1440	1500	1550	1650	1690
	9.0	9.8	10.4	10.10	11.4	11.10	12.3	12.8	13.0	13.4	13.8	14.0	14.4	14.7	14.11	15.2	15.5	15.11	16.5
	570	660	750	830	900	980	1050	1120	1190	1250	1310	1380	1440	1500	1560	1610	1670	1780	1880
	32.0				10.4	10.9	11.1	11.6	11.10	12.2	12.6	12.9	13.0	13.3	13.6	13.9	14.0	14.6	14.11
					1000	1080	1150	1240	1310	1380	1440	1520	1580	1640	1700	1770	1830	1970	2080
	12.0	13.10	14.11	15.10	16.8	17.5	18.1	18.9	19.11	20.6	21.0	21.6	21.11	22.5	22.10	23.3	23.7	24.5	25.1
	450	520	590	660	720	780	830	890	940	990	1040	1090	1140	1190	1230	1280	1320	1410	1490
	13.7	15.3	14.3	15.2	15.11	16.8	17.4	17.11	18.6	19.1	19.7	20.1	20.6	21.0	21.5	21.10	22.3	23.4	24.0
	470	550	620	690	750	810	870	930	980	1040	1090	1140	1190	1240	1290	1340	1380	1470	1560
2x12	12.7	13.8	14.4	15.2	15.10	16.5	17.0	17.7	18.1	18.7	19.1	19.6	19.11	20.4	20.9	21.1	21.6	22.2	22.10
	500	580	650	720	790	860	920	980	1040	1090	1150	1200	1250	1310	1360	1410	1460	1550	1640
	11.10	12.9	13.6	14.3	14.11	15.6	16.0	16.7	17.0	17.6	17.11	18.4	18.9	19.2	19.6	19.10	20.2	20.10	21.6
	530	610	690	770	840	910	970	1040	1100	1160	1220	1280	1330	1380	1440	1500	1550	1650	1750
	11.0	11.10	12.7	13.3	13.10	14.4	14.11	15.4	15.10	16.3	16.8	17.0	17.5	17.9	18.1	18.5	18.9	19.4	19.11
	570	660	750	830	900	980	1050	1120	1190	1250	1310	1380	1440	1500	1550	1610	1670	1780	1880
	32.0				12.7	13.1	13.6	13.11	14.4	14.9	15.2	15.6	15.10	16.2	16.5	16.9	17.0	17.7	18.1
					1000	1080	1150	1220	1300	1380	1450	1520	1580	1650	1700	1770	1830	1950	2070

Note: The required extreme fiber stress in bending, "F_b", in pounds per square inch is shown below each span.

TABLE J-2
FLOOR JOISTS
30 lbs. Per Sq. Ft. Live Load
(All rooms used for sleeping areas and attic floors.)

DESIGN CRITERIA:
Deflection - For 30 lbs. per sq. ft. live load.
Limited to span in inches divided by 360.
Strength - Live Load of 30 lbs. per sq. ft. plus
dead load of 10 lbs. per sq. ft. distributed
the required fiber stress value.

JOIST SIZE SPACING (IN)	Modulus of Elasticity, "E", in 1,000,000 psi																			
	0.4	0.5	0.6	0.7	0.8	0.9	1.0	1.1	1.2	1.3	1.4	1.5	1.6	1.7	1.8	1.9	2.0	2.2	2.4	
12.0	7-5	8-0	8-6	8-11	9-4	9-9	10-1	10-5	10-9	11-0	11-3	11-7	11-10	12-0	12-3	12-6	12-9	13-1	13-6	
	4-0	4-4	4-8	5-0	5-7	6-4	7-0	7-5	8-0	8-10	8-6	9-0	9-6	10-0	10-6	11-0	11-6	12-0	12-6	13-0
13.7	7-1	7-8	8-2	8-7	9-1	9-4	9-9	10-0	10-3	10-6	10-10	11-1	11-3	11-6	11-9	12-1	12-2	12-7	13-1	
	4-6	5-0	5-3	6-0	6-7	7-0	7-3	8-0	8-4	8-10	10-10	10-6	11-0	11-6	12-0	12-6	13-0	13-6	14-0	15-0
16.0	6-8	7-3	7-9	8-2	8-6	8-10	8-2	8-6	8-9	9-0	10-0	10-6	10-3	10-6	10-9	11-2	11-4	11-7	12-3	
	4-6	4-9	5-3	5-6	6-0	6-3	6-6	7-0	7-3	7-6	8-0	8-3	8-6	8-9	9-2	9-5	9-7	10-0	10-6	11-0
19.2	6-4	6-10	7-3	7-8	8-0	8-4	8-8	8-11	9-2	9-5	9-8	9-10	10-1	10-4	10-6	10-8	10-10	11-3	11-7	
	5-0	5-6	6-0	6-7	7-4	8-0	8-8	9-4	10-10	10-7	11-3	11-8	12-4	12-9	13-5	14-0	14-5	15-0	15-6	16-0
24.0	5-11	6-4	6-9	7-1	7-5	7-9	8-0	8-3	8-6	8-9	8-11	9-2	9-4	9-7	9-9	9-11	10-1	10-5	10-9	
	5-0	5-5	6-0	7-0	8-0	8-8	9-5	10-2	10-8	11-5	12-1	12-7	13-3	13-9	14-5	15-1	15-6	16-0	16-6	16-6
32.0	5-0	5-0	5-0	5-0	5-0	5-0	5-0	5-0	5-0	5-0	5-0	5-0	5-0	5-0	5-0	5-0	5-0	5-0	5-0	5-0
	5-0	5-0	5-0	5-0	5-0	5-0	5-0	5-0	5-0	5-0	5-0	5-0	5-0	5-0	5-0	5-0	5-0	5-0	5-0	5-0
12.0	9-10	10-7	11-3	11-10	12-4	12-10	13-4	13-9	14-2	14-6	14-11	15-3	15-7	15-10	16-2	16-9	17-4	17-10	17-10	
	4-0	4-4	4-8	5-0	5-7	6-4	7-0	7-5	8-0	8-10	8-6	9-0	9-6	10-0	10-6	11-0	11-6	12-0	12-6	13-0
13.7	9-4	10-1	10-8	11-4	12-8	12-3	12-8	13-2	13-6	13-11	14-3	14-7	14-11	15-2	15-6	15-9	16-0	16-7	17-0	
	4-6	5-0	5-3	6-0	6-7	7-0	7-3	8-0	8-4	9-0	9-6	10-10	10-6	11-0	11-6	12-0	12-6	13-0	13-6	14-0
16.0	8-11	9-7	10-2	10-9	11-3	11-8	12-1	12-6	12-10	13-2	13-6	13-10	14-2	14-5	14-8	15-0	15-3	15-9	16-2	
	4-6	5-0	5-3	6-0	6-7	7-0	7-3	8-0	8-4	9-0	9-6	10-10	10-6	11-0	11-6	12-0	12-6	13-0	13-6	14-0
19.2	8-5	9-0	9-7	10-1	10-7	11-0	11-4	11-9	12-1	12-5	12-9	13-4	13-8	13-7	13-10	14-1	14-4	14-9	15-3	
	5-0	5-6	6-0	6-7	7-4	8-0	8-8	9-4	10-10	10-7	11-3	11-8	12-4	12-9	13-5	14-0	14-5	15-0	15-6	16-0
24.0	7-8	8-5	8-11	9-4	9-10	10-2	10-7	10-11	11-3	11-8	11-10	12-1	12-4	12-7	12-10	13-1	13-4	13-8	14-2	
	5-0	5-5	6-0	7-0	8-0	8-8	9-5	10-2	10-8	11-5	12-1	12-7	13-3	13-9	14-5	15-1	15-6	16-2	17-0	18-0
32.0	5-0	5-0	5-0	5-0	5-0	5-0	5-0	5-0	5-0	5-0	5-0	5-0	5-0	5-0	5-0	5-0	5-0	5-0	5-0	5-0
	5-0	5-0	5-0	5-0	5-0	5-0	5-0	5-0	5-0	5-0	5-0	5-0	5-0	5-0	5-0	5-0	5-0	5-0	5-0	5-0

12.0	440	12-6	13-6	14-4	15-1	15-9	16-6	17-0	17-6	18-0	18-6	19-0	19-5	19-10	20-3	20-8	21-0	21-5	22-1	22-9
		11-1	12-11	13-8	14-5	15-1	15-8	16-3	16-9	17-3	17-9	18-2	18-7	19-0	19-4	19-9	20-1	20-5	21-1	21-9
13.7	460	530	600	670	730	790	840	890	900	950	1010	1060	1110	1160	1200	1250	1300	1340	1430	1510
16.0	480	550	630	700	770	830	880	940	950	1000	1060	1110	1160	1220	1270	1320	1380	1410	1500	1590
18.2	510	600	720	800	880	940	1000	1070	1080	1130	1190	1240	1290	1350	1400	1450	1500	1500	1600	1690
24.0	550	640	720	800	880	950	1020	1080	1150	1210	1270	1330	1390	1450	1510	1560	1620	1620	1720	1820
32.0					11-4	11-10	12-3	12-8	13-0	13-4	14-4	15-1	15-5	15-9	16-1	16-5	16-8	17-0	17-6	18-0
	15-2	16-5	17-5	18-4	19-2	19-11	20-8	21-4	21-11	22-6	23-1	23-7	24-2	24-8	25-1	25-7	26-0	26-10	27-3	27-9
12.0	440	510	570	640	700	750	810	860	910	960	1010	1060	1100	1150	1200	1240	1280	1370	1450	1510
13.7	460	530	600	670	730	790	840	900	950	1010	1060	1110	1160	1200	1250	1300	1340	1430	1510	1590
16.0	480	560	630	700	770	830	890	950	1000	1060	1110	1160	1220	1270	1320	1380	1410	1500	1590	1690
18.2	510	600	720	800	880	940	1000	1070	1130	1190	1240	1290	1350	1400	1450	1500	1500	1600	1690	1790
24.0	550	640	720	800	880	950	1020	1080	1150	1210	1270	1330	1390	1450	1510	1560	1620	1620	1720	1820
32.0					11-4	11-10	12-3	12-8	13-0	13-4	14-4	15-1	15-5	15-9	16-1	16-5	16-8	17-0	17-6	18-0
	15-2	16-5	17-5	18-4	19-2	19-11	20-8	21-4	21-11	22-6	23-1	23-7	24-2	24-8	25-1	25-7	26-0	26-10	27-3	27-9
12.0	440	510	570	640	700	750	810	860	910	960	1010	1060	1100	1150	1200	1240	1280	1370	1450	1510
13.7	460	530	600	670	730	790	840	900	950	1010	1060	1110	1160	1200	1250	1300	1340	1430	1510	1590
16.0	480	560	630	700	770	830	890	950	1000	1060	1110	1160	1220	1270	1320	1380	1410	1500	1590	1690
18.2	510	600	720	800	880	940	1000	1070	1130	1190	1240	1290	1350	1400	1450	1500	1500	1600	1690	1790
24.0	550	640	720	800	880	950	1020	1080	1150	1210	1270	1330	1390	1450	1510	1560	1620	1620	1720	1820
32.0					13-10	14-4	14-11	15-4	15-10	16-3	16-8	17-0	17-5	17-9	18-1	18-5	18-9	19-4	19-11	20-10
	15-2	16-5	17-5	18-4	19-2	19-11	20-8	21-4	21-11	22-6	23-1	23-7	24-2	24-8	25-1	25-7	26-0	26-10	27-3	27-9

Note: The required extreme fiber stress in bending, "F_b", in pounds per square inch is shown below each span.

TABLE J-3
CEILING JOISTS

20 Lbs. Per Sq. Ft. Live Load
(Limited attic storage where development of future rooms is not possible)
(Plaster Ceiling)

DESIGN CRITERIA:
Deflection - For 20 lbs. per sq. ft. live load.
Limited to span in inches divided by 360.
Strength - Live load of 20 lbs. per sq. ft. plus
dead load of 10 lbs. per sq. ft. determines
required fiber stress value.

JOIST SIZE SPACING (IN)	Modulus of Elasticity, "E", in 1,000,000 psi																			
	0.4	0.5	0.6	0.7	0.8	0.9	1.0	1.1	1.2	1.3	1.4	1.5	1.6	1.7	1.8	1.9	2.0	2.2	2.4	
12.0	5-5	5-10	6-2	6-6	6-10	7-1	7-4	7-7	7-10	8-0	8-3	8-5	8-7	8-9	8-11	9-1	9-5	9-7	9-10	
	4-30	5-00	5-60	6-30	6-90	7-40	7-90	8-50	9-00	9-50	9-90	10-40	10-90	11-30	11-70	12-20	12-60	13-40	14-20	
	5-2	5-7	5-11	6-3	6-6	6-9	7-0	7-3	7-6	7-8	7-10	8-1	8-3	8-5	8-7	8-8	8-10	9-2	9-5	
	4-50	5-20	5-90	6-50	7-20	7-70	8-30	8-80	9-40	9-90	10-40	10-90	11-40	11-90	12-30	12-70	13-20	14-00	14-90	
	4-11	5-4	5-8	5-11	6-2	6-5	6-8	6-11	7-1	7-3	7-6	7-8	7-10	8-0	8-1	8-3	8-5	8-8	8-11	
16.0	4-70	5-50	6-20	6-90	7-50	8-10	8-70	9-30	9-90	10-40	10-90	11-40	12-00	12-40	12-90	13-40	13-90	14-80	15-70	
	4-8	5-0	5-4	5-7	5-10	6-1	6-3	6-6	6-8	6-10	7-0	7-2	7-4	7-6	7-8	7-9	7-11	8-2	8-5	
	5-00	5-80	6-60	7-30	8-00	8-70	9-30	9-90	10-50	11-10	11-60	12-20	12-70	13-20	13-70	14-20	14-70	15-70	16-60	
	4-4	4-8	4-11	5-2	5-5	5-8	5-10	6-0	6-2	6-4	6-6	6-8	6-10	7-0	7-1	7-3	7-4	7-7	7-10	
	5-40	6-30	7-10	7-90	8-60	9-30	10-00	10-70	11-30	11-90	12-50	13-10	13-70	14-20	14-80	15-30	15-90	16-90	17-90	
24.0	8-6	9-2	9-9	10-3	10-9	11-2	11-7	11-11	12-3	12-7	12-11	13-3	13-6	13-9	14-1	14-4	14-7	15-0	15-6	
	4-30	5-00	5-60	6-30	6-90	7-40	7-90	8-50	9-00	9-50	9-90	10-40	10-90	11-30	11-70	12-20	12-60	13-40	14-20	
	8-2	8-9	9-4	9-10	10-3	10-8	11-1	11-5	11-9	12-1	12-4	12-8	12-11	13-2	13-5	13-8	13-11	14-4	14-9	
	4-50	5-20	5-90	6-50	7-20	7-70	8-30	8-80	9-40	9-90	10-40	10-90	11-40	11-90	12-30	12-70	13-20	14-00	14-90	
	7-9	8-4	8-10	9-4	9-8	10-2	10-6	10-10	11-2	11-5	11-9	12-0	12-3	12-6	12-9	13-0	13-3	13-8	14-1	
16.0	4-70	5-50	6-20	6-90	7-50	8-10	8-70	9-30	9-90	10-40	10-90	11-40	12-00	12-40	12-90	13-40	13-90	14-80	15-70	
	7-3	7-10	8-4	8-9	9-2	9-6	9-10	10-2	10-6	10-9	11-1	11-4	11-7	11-9	12-0	12-3	12-5	12-10	13-3	
	5-00	5-80	6-60	7-30	8-00	8-70	9-30	9-90	10-50	11-10	11-60	12-20	12-70	13-20	13-70	14-20	14-70	15-70	16-60	
	6-9	7-3	7-9	8-2	8-6	8-10	9-2	9-6	9-9	10-0	10-3	10-6	10-9	10-11	11-2	11-4	11-7	11-11	12-3	
	5-40	6-30	7-10	7-90	8-60	9-30	10-00	10-70	11-30	11-90	12-50	13-10	13-70	14-20	14-80	15-30	15-90	16-90	17-90	

2x8	12.0	11.3	12.1	12.10	13.6	14.2	14.8	15.3	15.9	16.2	16.7	17.0	17.5	17.10	18.2	18.5	18.10	19.2	19.10	20.5
		430	500	560	630	680	740	790	850	900	950	990	1040	1090	1130	1170	1220	1260	1340	1420
	13.7	10.9	11.7	12.3	12.11	13.6	14.1	14.7	15.0	15.6	15.11	16.3	16.8	17.0	17.5	17.9	18.0	18.4	18.11	19.6
		450	520	590	650	720	770	830	880	940	990	1040	1090	1140	1180	1230	1270	1320	1400	1490
	16.0	10.2	11.0	11.8	12.3	12.10	13.4	13.10	14.3	14.8	15.1	15.6	15.10	16.2	16.6	16.10	17.2	17.5	18.0	18.6
		470	550	620	690	750	810	870	930	990	1040	1090	1140	1200	1240	1290	1340	1390	1480	1570
	19.2	9.7	10.4	11.0	11.7	12.1	12.7	13.0	13.5	13.10	14.2	14.7	14.11	15.3	15.6	15.10	16.1	16.5	16.11	17.5
		500	580	660	730	800	870	930	990	1050	1110	1160	1220	1270	1320	1370	1420	1470	1570	1660
	24.0	5.0	6.30	7.10	7.90	8.60	9.30	10.00	10.70	11.30	11.90	12.50	13.10	13.70	14.20	14.80	15.30	15.90	16.90	17.90
		540	630	710	790	860	930	1000	1070	1130	1190	1250	1310	1370	1420	1480	1530	1590	1690	1790
2x10	12.0	14.4	15.5	16.5	17.3	18.0	18.9	19.5	20.1	20.8	21.2	21.9	22.3	22.9	23.2	23.8	24.1	24.6	25.3	26.0
		430	500	560	630	680	740	790	850	900	950	990	1040	1090	1130	1170	1220	1260	1340	1420
	13.7	13.8	14.9	15.8	16.6	17.3	17.11	18.7	19.2	19.9	20.3	20.9	21.3	21.9	22.2	22.7	23.0	23.5	24.2	24.10
		450	520	590	650	720	770	830	880	940	990	1040	1090	1140	1180	1230	1270	1320	1400	1490
	16.0	13.0	14.0	14.11	15.8	16.5	17.0	17.8	18.3	18.9	19.3	19.9	20.2	20.8	21.1	21.6	21.10	22.3	22.11	23.8
		470	550	620	690	750	810	870	930	990	1040	1090	1140	1200	1240	1290	1340	1390	1480	1570
	19.2	12.3	13.2	14.0	14.9	15.5	16.0	16.7	17.2	17.8	18.1	18.7	19.0	19.5	19.10	20.2	20.7	20.11	21.7	22.3
		500	580	660	730	800	870	930	990	1050	1110	1160	1220	1270	1320	1370	1420	1470	1570	1660
	24.0	11.4	12.3	13.0	13.8	14.4	14.11	15.5	15.11	15.5	15.10	17.3	17.8	18.0	18.5	18.9	19.1	19.5	20.1	20.8
		540	630	710	790	860	930	1000	1070	1130	1190	1250	1310	1370	1420	1480	1530	1590	1690	1790

Note: The required extreme fiber stress in bending, "F_b", in pounds per square inch is shown below each span.

TABLE J-4
CEILING JOISTS
20 Lbs. Per Sq. Ft. Live Load
(Limit load attic storage where development of future rooms is not possible)
(Drywall Ceiling)

DESIGN CRITERIA:
Deflection - For 20 lbs. per sq. ft. live load.
Limited to span in inches divided by 240.
Strength - Live load of 20 lbs. per sq. ft. plus dead load of 10 lbs. per sq. ft. determines required fiber stress value.

JOIST SIZE SPACING (IN)	Modulus of Elasticity, "E", in 1,000,000 psi																			
	0.4	0.5	0.6	0.7	0.8	0.9	1.0	1.1	1.2	1.3	1.4	1.5	1.6	1.7	1.8	1.9	2.0	2.2	2.4	
2x4	6-2	6-8	7-1	7-6	7-10	8-1	8-5	8-8	8-11	9-2	9-5	9-8	9-10	10-0	10-3	10-5	10-7	10-11	11-3	
	5-11	6-5	6-9	7-2	7-6	7-9	8-1	8-4	8-7	8-9	9-0	9-3	9-5	9-7	9-9	10-0	10-2	10-6	10-9	
	5-8	6-1	6-5	6-9	7-1	7-5	7-8	7-11	8-1	8-4	8-7	8-9	8-11	9-1	9-4	9-6	9-8	9-11	10-3	
	5-4	5-9	6-1	6-5	6-8	6-11	7-2	7-5	7-8	7-10	8-1	8-3	8-5	8-7	8-9	8-11	9-1	9-4	9-8	
	4-11	5-4	5-8	5-11	6-2	6-5	6-8	6-11	7-1	7-3	7-6	7-8	7-10	8-0	8-1	8-3	8-5	8-8	8-11	
	4-10	5-0	5-4	5-8	6-0	6-4	6-8	7-0	7-4	7-8	8-0	8-4	8-8	9-0	9-4	9-8	10-0	10-4	10-8	11-2
	3-10	4-0	4-4	4-8	5-0	5-4	5-8	6-0	6-4	6-8	7-0	7-4	7-8	8-0	8-4	8-8	9-0	9-4	9-8	10-2
	3-8	4-0	4-4	4-8	5-0	5-4	5-8	6-0	6-4	6-8	7-0	7-4	7-8	8-0	8-4	8-8	9-0	9-4	9-8	10-2
	3-6	3-8	4-0	4-2	4-4	4-6	4-8	5-0	5-2	5-4	5-6	5-8	6-0	6-2	6-4	6-6	6-8	7-0	7-2	7-4
	3-4	3-6	3-8	4-0	4-2	4-4	4-6	4-8	5-0	5-2	5-4	5-6	5-8	6-0	6-2	6-4	6-6	6-8	7-0	7-2
2x6	8-4	9-0	9-6	10-0	10-6	11-0	11-4	11-8	12-0	12-4	12-8	13-0	13-4	13-8	14-0	14-4	14-8	15-2	15-6	
	8-2	8-8	9-4	10-0	10-6	11-0	11-4	11-8	12-2	12-6	13-0	13-4	13-8	14-2	14-6	15-0	15-4	15-8	16-2	
	8-0	8-6	9-2	9-8	10-4	11-0	11-6	12-0	12-4	12-8	13-2	13-6	14-0	14-4	14-8	15-2	15-6	16-0	16-4	
	7-8	8-4	9-0	9-6	10-2	10-8	11-4	12-0	12-4	12-8	13-2	13-6	14-0	14-4	14-8	15-2	15-6	16-0	16-4	
	7-6	8-2	8-8	9-4	10-0	10-6	11-2	11-8	12-2	12-6	13-0	13-4	13-8	14-2	14-6	15-0	15-4	15-8	16-2	
	7-4	8-0	8-6	9-2	9-8	10-4	11-0	11-6	12-0	12-4	12-8	13-2	13-6	14-0	14-4	14-8	15-2	15-6	16-0	16-4
	7-2	7-8	8-4	9-0	9-6	10-2	10-8	11-4	11-8	12-2	12-6	13-0	13-4	13-8	14-2	14-6	15-0	15-4	15-8	16-2
	7-0	7-6	8-2	8-8	9-4	10-0	10-6	11-2	11-6	12-0	12-4	12-8	13-2	13-6	14-0	14-4	14-8	15-2	15-6	16-0
	6-10	7-0	7-10	8-0	8-10	9-0	9-10	10-0	10-10	11-0	11-10	12-0	12-10	13-0	13-10	14-0	14-10	15-0	15-10	16-0
	6-8	7-8	8-8	9-8	10-8	11-8	12-8	13-8	14-8	15-8	16-8	17-8	18-8	19-8	20-8	21-8	22-8	23-8	24-8	25-8

12.0	12-10	13-10	14-8	15-6	16-2	16-10	17-5	18-0	18-6	19-0	19-6	19-11	20-5	20-10	21-2	21-7	21-11	22-8	23-4
	560	660	740	820	900	970	1040	1110	1170	1240	1300	1360	1420	1480	1540	1600	1650	1760	1860
13.7	12-3	13-3	14-1	14-10	15-6	16-1	16-8	17-2	17-9	18-2	18-8	19-1	19-6	19-11	20-3	20-8	21-0	21-8	22-4
	590	690	770	860	940	1010	1090	1160	1230	1300	1360	1420	1490	1550	1610	1670	1730	1840	1950
16.0	11-8	12-7	13-4	14-1	14-8	15-3	15-10	16-4	16-10	17-3	17-9	18-2	18-6	18-11	19-3	19-7	19-11	20-7	21-2
	620	720	810	900	980	1070	1140	1220	1290	1360	1430	1500	1570	1630	1690	1760	1820	1940	2050
19.2	11-0	11-10	12-7	13-3	13-10	14-5	14-11	15-5	15-10	16-3	16-8	17-1	17-5	17-9	18-2	18-5	18-9	19-5	19-11
	660	770	870	960	1050	1130	1220	1300	1370	1450	1520	1590	1660	1730	1800	1870	1930	2060	2180
24.0	10-2	11-0	11-8	12-3	12-10	13-4	13-10	14-3	14-8	15-1	15-6	15-10	16-2	16-6	16-10	17-2	17-5	18-0	18-6
	710	830	930	1030	1130	1220	1310	1400	1480	1560	1640	1720	1790	1870	1940	2010	2080	2220	2350
12.0	16-5	17-8	18-9	19-9	20-8	21-6	22-3	22-11	23-8	24-3	24-10	25-5	26-0	26-6	27-1	27-6	28-0	28-11	29-9
	560	660	740	820	900	970	1040	1110	1170	1240	1300	1360	1420	1480	1540	1600	1650	1760	1860
13.7	15-8	16-11	17-11	18-11	19-9	20-6	21-3	21-11	22-7	23-3	23-9	24-4	24-10	25-5	25-10	26-4	26-10	27-8	28-6
	590	690	770	860	940	1010	1090	1160	1230	1300	1360	1420	1490	1550	1610	1670	1730	1840	1950
16.0	14-11	16-0	17-0	17-11	18-9	19-6	20-2	20-10	21-6	22-1	22-7	23-2	23-8	24-1	24-7	25-0	25-5	26-3	27-1
	620	720	810	900	990	1070	1140	1220	1290	1360	1430	1500	1570	1630	1690	1760	1820	1940	2050
19.2	14-0	15-1	16-0	16-11	17-8	18-4	19-0	19-7	20-2	20-9	21-3	21-9	22-3	22-8	23-2	23-7	23-11	24-9	25-5
	660	770	870	960	1050	1130	1220	1300	1370	1450	1520	1590	1660	1730	1800	1870	1930	2060	2180
24.0	13-0	14-0	14-11	15-8	16-5	17-0	17-8	18-3	18-9	19-3	19-9	20-2	20-8	21-1	21-6	21-10	22-3	22-11	23-8
	710	830	930	1030	1130	1220	1310	1400	1480	1560	1640	1720	1790	1870	1940	2010	2080	2220	2350

Note: The required extreme fiber stress in bending, "F_b", in pounds per square inch is shown below each span.

**TABLE JS
CEILING JOISTS**
10 Lbs. Per Sq. Ft. Live Load
(No attic storage and roof slope not steeper than 3 in 12)

DESIGN CRITERIA:
Deflection - For 10 lbs. per sq. ft. live load,
Limited to span in inches divided by 360.
Strength - live load of 10 lbs. per sq. ft. plus
dead load of 5 lbs. per sq. ft. determines
required fiber stress value.

JOIST SIZE SPACING (IN)	Modulus of Elasticity, "E", in 1,000,000 psi																			
	0.4	0.5	0.6	0.7	0.8	0.9	1.0	1.1	1.2	1.3	1.4	1.5	1.6	1.7	1.8	1.9	2.0	2.2	2.4	
12.0	6-10	7-4	7-10	8-3	8-7	8-11	9-3	9-7	9-10	10-1	10-4	10-7	10-10	11-1	11-3	11-6	11-8	12-1	12-5	
	3-6	4-0	4-6	5-0	5-4	5-8	6-3	6-7	7-10	7-5	7-9	8-30	8-60	9-00	9-30	9-70	10-00	10-70	11-30	
	6-6	7-0	7-6	7-10	8-3	8-7	8-10	8-10	8-5	8-8	8-20	8-20	8-80	9-00	9-40	10-0	10-10	10-50	11-10	
	3-6	4-0	4-70	5-20	5-70	6-10	6-60	7-00	7-40	7-80	8-20	8-60	9-00	9-40	9-80	10-30	10-60	11-00	11-80	
	6-2	6-8	7-1	7-6	7-10	8-1	8-5	8-9	8-11	9-2	9-5	9-8	9-10	10-0	10-3	10-5	10-7	10-11	10-11	11-3
16.0	5-10	6-2	6-8	7-0	7-4	7-8	7-11	8-2	8-5	8-8	8-10	9-1	9-3	9-5	9-8	9-10	10-0	10-4	10-7	
	4-0	4-60	5-20	5-80	6-30	6-90	7-40	7-90	8-30	8-80	9-20	9-70	10-10	10-50	10-90	11-30	11-70	12-50	13-20	
	5-5	5-10	6-2	6-6	6-10	7-1	7-4	7-7	7-10	8-0	8-3	8-5	8-7	8-9	8-11	9-1	9-3	9-7	9-10	
	4-30	5-00	5-60	6-30	6-90	7-40	7-90	8-50	9-00	9-50	9-90	10-40	10-90	11-30	11-70	12-20	12-60	13-40	14-20	
	10-9	11-7	12-3	12-11	13-5	14-1	14-7	15-0	15-6	15-11	16-3	16-8	17-0	17-4	17-9	18-0	18-4	18-11	19-6	
18.2	3-6	4-0	4-60	5-00	5-40	5-80	6-30	6-70	7-10	7-50	7-90	8-30	8-60	9-00	9-30	9-70	10-00	10-70	11-30	
	10-3	11-1	11-9	12-4	12-11	13-5	13-11	14-4	14-9	15-2	15-7	15-11	15-3	15-7	15-11	15-11	15-3	15-7	16-8	
	3-6	4-0	4-70	5-20	5-70	6-10	6-60	7-00	7-40	7-80	8-20	8-60	9-00	9-40	9-70	10-10	10-50	11-10	11-80	
	9-9	10-6	11-2	11-9	12-3	12-9	13-3	13-8	14-1	14-5	14-9	15-2	15-6	15-9	16-1	16-4	16-8	17-2	17-8	
	9-2	9-10	10-6	11-1	11-7	12-0	12-5	12-10	13-3	13-7	14-1	14-3	14-7	14-10	15-2	15-5	15-8	16-2	16-8	
24.0	3-6	4-0	4-60	5-20	5-80	6-30	6-90	7-40	7-90	8-30	8-80	9-20	9-70	10-10	10-50	10-90	11-30	11-70	12-50	
	8-6	9-2	9-9	10-3	10-9	11-2	11-7	11-11	12-3	12-7	12-11	13-3	13-6	13-9	14-1	14-4	14-7	15-0	15-6	
	4-30	5-00	5-60	6-30	6-90	7-40	7-90	8-50	9-00	9-50	9-90	10-40	10-90	11-30	11-70	12-20	12-60	13-40	14-20	
	10-9	11-7	12-3	12-11	13-5	14-1	14-7	15-0	15-6	15-11	16-3	16-8	17-0	17-4	17-9	18-0	18-4	18-11	19-6	
	3-6	4-0	4-70	5-20	5-70	6-10	6-60	7-00	7-40	7-80	8-20	8-60	9-00	9-40	9-70	10-10	10-50	11-10	11-80	

12.0	14-2	15-3	16-2	17-0	17-10	18-6	19-2	19-10	20-5	20-11	21-5	21-11	22-5	22-11	23-4	23-9	24-2	24-11	25-8
	340	400	450	500	540	590	630	670	710	750	790	830	860	900	930	970	1000	1070	1130
13.7	13-6	14-7	15-6	16-3	17-0	17-9	18-4	18-11	19-6	20-0	20-6	21-0	21-5	21-11	22-4	22-9	23-1	23-10	24-7
	360	410	470	520	570	610	660	700	740	780	820	860	900	940	970	1010	1050	1110	1180
16.0	12-10	13-10	14-8	15-6	16-2	16-10	17-5	18-0	18-6	19-0	19-6	19-11	20-5	20-10	21-2	21-7	21-11	22-6	23-4
	380	440	490	550	600	650	690	740	780	830	870	910	950	990	1030	1060	1100	1170	1240
19.2	12-1	13-0	13-10	14-7	15-3	15-10	16-5	16-11	17-5	17-11	18-4	18-9	19-2	19-7	19-11	20-4	20-8	21-4	21-11
	400	460	520	580	630	690	740	790	830	880	920	970	1010	1050	1090	1130	1170	1250	1320
24.0	11-3	12-1	12-10	13-6	14-2	14-8	15-3	15-9	16-2	16-7	17-0	17-5	17-10	18-2	18-6	18-10	19-2	19-10	20-5
	430	500	560	630	680	740	790	850	900	950	980	1040	1090	1130	1170	1220	1260	1340	1420
12.0	18-0	19-5	20-8	21-9	22-9	23-8	24-6	25-3	26-0	26-9	27-5	28-0	28-7	29-2	29-9	30-4	30-10	31-0	32-9
	340	400	450	500	540	590	630	670	710	750	790	830	860	900	930	970	1000	1070	1130
13.7	17-3	18-7	19-9	20-9	21-9	22-7	23-5	24-2	24-10	25-7	26-2	26-10	27-5	27-11	28-6	29-0	29-6	30-5	31-4
	360	410	470	520	570	610	660	700	740	780	820	860	900	940	970	1010	1050	1110	1180
16.0	16-5	17-8	18-9	19-9	20-9	21-6	22-3	22-11	23-8	24-3	24-10	25-5	26-0	26-6	27-1	27-6	28-0	28-11	29-9
	380	440	490	550	600	650	690	740	780	830	870	910	950	990	1030	1060	1100	1170	1240
19.2	15-5	16-7	17-8	18-7	19-5	20-2	20-11	21-7	22-3	22-10	23-5	23-11	24-6	25-0	25-5	25-11	26-4	27-3	28-0
	400	460	520	580	630	690	740	790	830	880	920	970	1010	1050	1090	1130	1170	1250	1320
24.0	14-4	15-5	16-5	17-3	18-0	18-9	19-5	20-1	20-9	21-2	21-9	22-3	22-9	23-2	23-8	24-1	24-6	25-3	26-0
	430	500	560	630	680	740	790	850	900	950	990	1040	1090	1130	1170	1220	1260	1340	1420

Note: The required extreme fiber stress in bonding, "F," in pounds per square inch is shown below each span.

TABLE 15
CEILING JOISTS

10 Lbs. Per Sq. Ft. Live Load
(No attic storage and roof slope not steeper than 3 in 12)
(Drywall Ceiling)

DESIGN CRITERIA:
Deflection - For 10 lbs. per sq. ft. live load.
Limited to span in inches divided by 240.
Strength - live load of 10 lbs. per sq. ft. plus
dead load of 5 lbs. per sq. ft. determines
required fiber stress value.

JOIST SIZE SPACING (IN)	Modulus of Elasticity, "E", in 1,000,000 psi																			
	0.4	0.5	0.6	0.7	0.8	0.9	1.0	1.1	1.2	1.3	1.4	1.5	1.6	1.7	1.8	1.9	2.0	2.2	2.4	
12.0	7.10	8.5	8.11	9.5	9.70	10.3	10.7	10.71	11.3	11.7	11.10	12.2	12.5	12.9	13.17	13.2	13.4	13.9	14.3	
	4.50	5.20	5.90	6.50	7.10	7.70	8.30	8.90	9.50	9.80	10.30	10.80	11.30	11.80	12.20	12.70	13.10	14.00	14.80	
	13.7	4.70	5.40	6.10	6.80	7.40	8.00	8.60	9.20	9.70	10.30	10.80	11.30	11.80	12.30	12.80	13.20	13.70	14.60	
	2x4	7.1	7.8	8.1	8.7	8.11	8.4	8.8	9.11	9.3	9.6	10.2	10.4	10.7	10.10	11.0	11.3	11.5	11.9	12.2
		4.80	5.70	6.30	7.20	7.80	8.50	9.10	9.70	10.30	10.80	11.40	11.90	12.40	12.90	13.40	13.90	14.40	15.40	16.30
		19.2	5.20	6.10	6.80	7.60	8.30	9.00	9.70	10.30	10.90	11.50	12.10	12.70	13.20	13.80	14.30	14.80	15.30	16.30
2x6		6.2	6.8	7.1	7.6	7.10	8.1	8.5	8.8	9.11	9.2	9.5	9.8	9.70	10.3	10.3	10.5	10.7	10.11	11.3
		5.60	6.60	7.40	8.20	9.00	9.70	10.40	11.10	11.70	12.40	13.00	13.60	14.20	14.80	15.40	16.00	16.50	17.60	18.60
		12.3	13.3	14.1	14.9	15.6	16.1	16.6	17.2	17.8	18.2	18.8	19.1	19.6	19.11	20.3	20.6	21.0	21.6	22.4
	4.50	5.20	5.90	6.50	7.10	7.70	8.30	8.90	9.50	9.80	10.30	10.80	11.30	11.80	12.20	12.70	13.10	14.00	14.80	
	13.7	4.70	5.40	6.10	6.80	7.40	8.00	8.60	9.20	9.70	10.30	10.80	11.30	11.80	12.30	12.80	13.20	13.70	14.60	
	16.0	11.2	12.6	12.9	13.5	14.1	14.7	15.2	15.7	16.1	16.6	16.11	17.4	17.8	18.3	18.5	18.9	19.1	19.8	20.3
4.90		5.70	6.50	7.20	7.80	8.50	9.10	9.70	10.30	10.80	11.40	11.90	12.40	12.90	13.40	13.90	14.40	15.40	16.30	
19.2		5.20	6.10	6.90	7.60	8.30	9.00	9.70	10.30	10.90	11.50	12.10	12.70	13.20	13.80	14.30	14.80	15.30	16.30	
2x8		9.8	10.6	11.2	11.9	12.3	12.9	13.3	13.8	14.7	14.5	14.9	15.2	15.6	15.9	16.1	16.4	16.8	17.2	17.8
		5.80	6.60	7.40	8.20	9.00	9.70	10.40	11.10	11.70	12.40	13.00	13.60	14.20	14.80	15.40	16.00	16.50	17.50	18.60

12.0	16.2	17.5	18.6	19.6	20.5	21.2	21.11	22.8	23.4	24.0	24.7	25.2	25.8	26.2	26.9	27.2	27.8	28.7	29.5
	450	520	590	650	710	770	830	880	930	980	1030	1080	1130	1180	1220	1270	1310	1400	1480
	15.6	16.8	17.9	18.8	19.5	20.3	21.0	21.8	22.4	22.11	23.6	24.0	24.7	25.1	25.7	26.0	26.6	27.4	28.1
13.7	470	540	610	680	740	800	860	920	970	1030	1080	1130	1180	1230	1280	1320	1370	1460	1550
	14.8	15.10	16.10	17.9	18.6	19.3	19.11	20.7	21.2	21.9	22.4	22.10	23.4	23.10	24.3	24.8	25.2	25.11	26.9
	490	570	650	720	780	850	910	970	1030	1080	1140	1190	1240	1290	1340	1380	1440	1540	1630
19.2	13.10	14.11	15.10	16.8	17.6	18.2	18.5	19.5	19.11	20.5	21.0	21.6	22.10	22.5	22.10	23.3	23.8	24.5	25.2
	520	610	690	760	830	900	970	1030	1090	1150	1210	1270	1320	1380	1430	1490	1530	1630	1730
	12.10	13.10	14.8	15.6	16.2	16.10	17.5	18.0	18.6	19.0	19.6	19.11	20.5	20.10	21.2	21.7	21.11	22.8	23.4
24.0	560	660	740	820	900	970	1040	1110	1170	1240	1300	1360	1420	1480	1540	1600	1650	1760	1860
	20.8	22.3	23.8	24.10	26.0	27.1	28.0	28.11	29.9	30.7	31.4	32.1	32.9	33.5	34.1	34.8	35.4	36.5	37.5
	490	520	590	650	710	770	830	880	930	980	1030	1080	1130	1180	1220	1270	1310	1400	1490
13.7	19.9	21.3	22.7	23.9	24.10	25.10	26.10	27.8	28.6	29.3	30.0	30.8	31.4	32.0	32.7	33.2	33.9	34.70	35.10
	470	540	610	680	740	800	860	920	970	1030	1080	1130	1180	1230	1280	1320	1370	1460	1550
	18.9	20.2	21.6	22.7	23.8	24.7	25.5	26.3	27.1	27.9	28.6	29.2	29.9	30.5	31.0	31.6	32.1	33.1	34.1
16.0	490	570	650	720	780	850	910	970	1030	1080	1140	1190	1240	1290	1340	1390	1440	1540	1630
	17.8	19.0	20.2	21.3	22.3	23.2	23.11	24.9	25.5	26.2	26.10	27.5	28.0	28.7	29.2	29.8	30.2	31.2	32.1
	520	610	690	760	830	900	970	1030	1090	1150	1210	1270	1320	1380	1430	1480	1530	1630	1730
19.2	16.5	17.8	18.9	19.9	20.8	21.6	22.3	22.11	23.8	24.3	24.10	25.5	26.0	26.6	27.1	27.6	28.0	28.11	29.9
	560	660	740	820	900	970	1040	1110	1170	1240	1300	1360	1420	1480	1540	1600	1650	1760	1860
	24.0	24.0	24.0	24.0	24.0	24.0	24.0	24.0	24.0	24.0	24.0	24.0	24.0	24.0	24.0	24.0	24.0	24.0	24.0

Note: The required extreme fiber stress in bending, "F_b", in pounds per square inch is shown below each span.

TABLE R-2
FLAT OR SLOPED RAFTERS
Supporting Drywall Ceiling
 (Flat roof or cathedral ceiling with no attic space)

Live Load - 30 lb. per sq. ft.
 Use in Zone 2

DESIGN CRITERIA:

Strength - 15 lbs. per sq. ft. dead load plus 30
 lbs. per sq. ft. live load determines required
 fiber stress.

Deflection - For 30 lbs. per sq. ft. live load.
 Limited to span in inches divided by 240.

RAFTER SIZE SPACING (IN) (IN)		Extreme Fiber Stress in Bending, "F _b " (psi).										
		300	400	500	600	700	800	900	1000	1100	1200	1300
2x6	12.0	5-10 0.13	6-8 0.19	7-6 0.27	8-2 0.36	8-10 0.45	9-6 0.55	10-0 0.66	10-7 0.77	11-1 0.89	11-7 1.01	12-1 1.14
	13.7	5-5 0.12	6-3 0.18	7-0 0.25	7-8 0.33	8-3 0.42	8-10 0.52	9-5 0.61	9-11 0.72	10-5 0.83	10-10 0.95	11-3 1.07
	16.0	5-0 0.11	5-10 0.17	6-6 0.24	7-1 0.31	7-8 0.39	8-2 0.48	8-8 0.57	9-2 0.67	9-7 0.77	10-0 0.88	10-5 0.99
	19.2	4-7 0.10	5-4 0.15	5-11 0.22	6-6 0.28	7-0 0.36	7-6 0.44	7-11 0.52	8-4 0.61	8-9 0.70	9-2 0.80	9-6 0.90
	24.0	4-1 0.09	4-9 0.14	5-4 0.19	5-10 0.25	6-3 0.32	6-8 0.39	7-1 0.46	7-6 0.54	7-10 0.63	8-2 0.72	8-8 0.81
2x8	12.0	7-8 0.13	8-10 0.19	9-10 0.27	10-10 0.36	11-8 0.45	12-6 0.55	13-3 0.66	13-11 0.77	14-8 0.89	15-3 1.01	15-11 1.14
	13.7	7-2 0.12	8-3 0.18	9-3 0.25	10-1 0.33	10-11 0.42	11-8 0.52	12-5 0.61	13-1 0.72	13-8 0.83	14-4 0.95	14-11 1.07
	16.0	6-7 0.11	7-8 0.17	8-7 0.24	9-4 0.31	10-1 0.39	10-10 0.48	11-6 0.57	12-1 0.67	12-8 0.77	13-3 0.88	13-9 0.99
	19.2	6-1 0.10	7-0 0.15	7-10 0.22	8-7 0.28	9-3 0.36	9-10 0.44	10-6 0.52	11-0 0.61	11-7 0.70	12-1 0.80	12-7 0.90
	24.0	5-5 0.09	6-3 0.14	7-0 0.19	7-8 0.25	8-3 0.32	8-10 0.39	9-4 0.46	9-10 0.54	10-4 0.63	10-10 0.72	11-3 0.81

2x10	12.0	9-9 0.13	11-3 0.19	12-7 0.27	13-9 0.36	14-11 0.45	15-11 0.55	16-11 0.66	17-10 0.77	18-8 0.89	19-6 1.01	20-4 1.14
	13.7	9-1 0.12	10-6 0.18	11-9 0.25	12-11 0.33	13-11 0.42	14-11 0.52	15-10 0.61	16-8 0.72	17-6 0.83	18-3 0.95	19-0 1.07
	16.0	8-5 0.11	9-9 0.17	10-11 0.24	11-11 0.31	12-11 0.39	13-9 0.48	14-8 0.57	15-5 0.67	16-2 0.77	16-11 0.88	17-7 0.99
	19.2	7-8 0.10	8-11 0.15	9-11 0.22	10-11 0.28	11-9 0.36	12-7 0.44	13-4 0.52	14-1 0.61	14-9 0.70	15-5 0.80	16-1 0.90
	24.0	6-11 0.09	8-0 0.14	8-11 0.19	9-9 0.25	10-6 0.32	11-3 0.39	11-11 0.46	12-7 0.54	13-2 0.63	13-9 0.72	14-4 0.81
2x12	12.0	11-10 0.13	13-8 0.19	15-4 0.27	16-9 0.36	18-1 0.45	19-4 0.55	20-6 0.66	21-8 0.77	22-8 0.89	23-9 1.01	24-8 1.14
	13.7	11-1 0.12	12-10 0.18	14-4 0.25	15-8 0.33	16-11 0.42	18-1 0.52	19-3 0.61	20-3 0.72	21-3 0.83	22-2 0.95	23-1 1.07
	16.0	10-3 0.11	11-10 0.17	13-3 0.24	14-6 0.31	15-8 0.39	16-9 0.48	17-9 0.57	18-9 0.67	19-8 0.77	20-6 0.88	21-5 0.99
	19.2	9-5 0.10	10-10 0.15	12-1 0.22	13-3 0.28	14-4 0.36	15-4 0.44	16-3 0.52	17-1 0.61	17-11 0.70	18-9 0.80	19-6 0.90
	24.0	8-5 0.09	9-8 0.14	10-10 0.19	11-10 0.25	12-10 0.32	13-8 0.39	14-6 0.46	15-4 0.54	16-1 0.63	16-9 0.72	17-5 0.81

Note: The required modulus of elasticity, "E", in 1,000,000 pounds per square inch is shown below each span.

TABLE R-2 (cont.)

RAFTERS: Spans are measured along the horizontal projection and loads are considered as applied on the horizontal projection.

Extreme Fiber Stress in Bending, "F _b " (psi).											RAFTER SPACING SIZE (IN)		
1400	1500	1600	1700	1800	1900	2000	2100	2200	2400	2700			
12-6 1.28	13-0 1.41	13-5 1.56	13-10 1.71	14-2 1.86	14-7 2.02	15-0 2.18	15-4 2.34	15-8 2.51				12.0	
11-9 1.19	12-2 1.32	12-6 1.46	12-11 1.60	13-3 1.74	13-8 1.89	14-0 2.04	14-4 2.19	14-8 2.35				13.7	
10-10 1.10	11-3 1.22	11-7 1.35	11-11 1.48	12-4 1.61	12-8 1.75	13-0 1.89	13-3 2.03	13-7 2.18	14-2 2.48			16.0	2x6
9-11 1.01	10-3 1.12	10-7 1.23	10-11 1.35	11-3 1.47	11-6 1.59	11-10 1.72	12-2 1.85	12-5 1.99	13-0 2.26			19.2	
8-10 0.90	9-2 1.00	9-6 1.10	9-9 1.21	10-0 1.31	10-4 1.43	10-7 1.54	10-10 1.66	11-1 1.78	11-7 2.02	12-4 2.41		24.0	
16-6 1.28	17-1 1.41	17-8 1.56	18-2 1.71	18-9 1.86	19-3 2.02	19-9 2.18	20-3 2.34	20-8 2.51				12.0	2x8
15-5 1.19	16-0 1.32	16-6 1.46	17-0 1.60	17-6 1.74	18-0 1.89	18-5 2.04	18-11 2.19	19-4 2.35				13.7	
14-4 1.10	14-10 1.22	15-3 1.35	15-9 1.48	16-3 1.61	16-8 1.75	17-1 1.89	17-6 2.03	17-11 2.18	18-9 2.48			16.0	
13-1 1.01	13-6 1.12	13-11 1.23	14-5 1.35	14-10 1.47	15-2 1.59	15-7 1.72	16-0 1.85	16-4 1.99	17-1 2.26			19.2	
11-8 0.90	12-1 1.00	12-6 1.10	12-10 1.21	13-3 1.31	13-7 1.43	13-11 1.54	14-4 1.66	14-8 1.78	15-3 2.02	16-3 2.41		24.0	

21-1 1.28	21-10 1.41	22-6 1.56	23-3 1.71	23-11 1.86	24-6 2.02	25-2 2.18	25-10 2.34	26-5 2.51			12.0	2x10
19-8 1.19	20-5 1.32	21-1 1.46	21-9 1.60	22-4 1.74	22-11 1.89	23-7 2.04	24-2 2.19	24-8 2.35			13.7	
18-3 1.10	18-11 1.22	19-6 1.35	20-1 1.48	20-8 1.61	21-3 1.75	21-10 1.89	22-4 2.03	22-10 2.18	23-11 2.48		16.0	
16-8 1.01	17-3 1.12	17-10 1.23	18-4 1.35	18-11 1.47	19-5 1.59	19-11 1.72	20-5 1.85	20-10 1.99	21-10 2.26		19.2	
14-11 0.90	15-5 1.00	15-11 1.10	16-5 1.21	16-11 1.31	17-4 1.43	17-10 1.54	18-3 1.66	18-8 1.78	19-6 2.02	20-8 2.41	24.0	
25-7 1.28	26-6 1.41	27-5 1.56	28-3 1.71	29-1 1.86	29-10 2.02	30-7 2.18	31-4 2.34	32-1 2.51			12.0	2x12
24-0 1.19	24-10 1.32	25-7 1.46	26-5 1.60	27-2 1.74	27-11 1.89	28-8 2.04	29-4 2.19	30-0 2.35			13.7	
22-2 1.10	23-0 1.22	23-9 1.35	24-5 1.48	25-2 1.61	25-10 1.75	26-6 1.89	27-2 2.03	27-10 2.18	29-1 2.48		16.0	
20-3 1.01	21-0 1.12	21-8 1.23	22-4 1.35	23-0 1.47	23-7 1.59	24-2 1.72	24-10 1.85	25-5 1.99	26-6 2.26		19.2	
18-1 0.90	18-9 1.00	19-4 1.10	20-0 1.21	20-6 1.31	21-1 1.43	21-8 1.54	22-2 1.66	22-8 1.78	23-9 2.02	25-2 2.41	24.0	

Note: The required modulus of elasticity, "E", in 1,000,000 pounds per square inch is shown below each span.

TABLE R-3
FLAT OR SLOPED RAFTERS
Supporting Drywall Ceiling
 (Flat roof or cathedral ceiling with no attic space)
 Live Load - 40 lbs. per sq. ft.
 Use in Zone 1

DESIGN CRITERIA:

Strength - 15 lbs. per sq. ft. dead load plus 40 lbs. per sq. ft. live load determines required fiber stress.

Deflection - For 40 lbs. per sq. ft. live load. Limited to span in inches divided by 240.

RAFTER SIZE SPACING (IN) (IN)		Extreme Fiber Stress in Bending, "F _b " (psi).										
		300	400	500	600	700	800	900	1000	1100	1200	1300
2x6	12.0	5-3 0.12	6-1 0.19	6-9 0.27	7-5 0.35	8-0 0.44	8-7 0.54	9-1 0.65	9-7 0.76	10-0 0.88	10-6 1.00	10-11 1.13
	13.7	4-11 0.12	5-8 0.18	6-4 0.25	6-11 0.33	7-6 0.42	8-0 0.51	8-6 0.61	8-11 0.71	9-5 0.82	9-10 0.93	10-3 1.05
	16.0	4-6 0.11	5-3 0.17	5-10 0.23	6-5 0.31	6-11 0.39	7-5 0.47	7-10 0.56	8-3 0.66	8-8 0.76	9-1 0.86	9-5 0.98
	19.2	4-2 0.10	4-9 0.15	5-4 0.21	5-10 0.28	6-4 0.35	6-9 0.43	7-2 0.51	7-7 0.60	7-11 0.69	8-3 0.79	8-8 0.89
	24.0	3-8 0.09	4-3 0.14	4-9 0.19	5-3 0.25	5-8 0.31	6-1 0.38	6-5 0.46	6-9 0.54	7-1 0.62	7-5 0.71	7-9 0.80
	12.0	6-11 0.12	8-0 0.19	8-11 0.27	9-9 0.35	10-7 0.44	11-3 0.54	12-0 0.65	12-7 0.76	13-3 0.88	13-10 1.00	14-5 1.13
2x8	13.7	6-6 0.12	7-6 0.18	8-4 0.25	9-2 0.33	9-11 0.42	10-7 0.51	11-2 0.61	11-10 0.71	12-5 0.82	12-11 0.93	13-6 1.05
	16.0	6-0 0.11	6-11 0.17	7-9 0.23	8-6 0.31	9-2 0.39	9-9 0.47	10-4 0.56	10-11 0.66	11-6 0.76	12-0 0.86	12-6 0.98
	19.2	5-6 0.10	6-4 0.15	7-1 0.21	7-9 0.28	8-4 0.35	8-11 0.43	9-6 0.51	10-0 0.60	10-6 0.69	10-11 0.79	11-5 0.89
	24.0	4-11 0.09	5-8 0.14	6-4 0.19	6-11 0.25	7-6 0.31	8-0 0.38	8-6 0.46	8-11 0.54	9-4 0.62	9-9 0.71	10-2 0.80

2x10	12.0	8-10 0.12	10-2 0.19	11-5 0.27	12-6 0.35	13-6 0.44	14-5 0.54	15-3 0.65	16-1 0.76	16-11 0.88	17-8 1.00	18-4 1.13
	13.7	8-3 0.12	9-6 0.18	10-8 0.25	11-8 0.33	12-7 0.42	13-6 0.51	14-3 0.61	15-1 0.71	15-10 0.82	16-6 0.93	17-2 1.05
	16.0	7-8 0.11	8-10 0.17	9-10 0.23	10-10 0.31	11-8 0.39	12-6 0.47	13-3 0.56	13-11 0.66	14-8 0.76	15-3 0.86	15-11 0.98
	19.2	7-0 0.10	8-1 0.15	9-0 0.21	9-10 0.28	10-8 0.35	11-5 0.43	12-1 0.51	12-9 0.60	13-4 0.69	13-11 0.79	14-6 0.89
	24.0	6-3 0.09	7-2 0.14	8-1 0.19	8-10 0.25	9-6 0.31	10-2 0.38	10-10 0.46	11-5 0.54	11-11 0.62	12-6 0.71	13-0 0.80
2x12	12.0	10-9 0.12	12-5 0.19	13-10 0.27	15-2 0.35	16-5 0.44	17-6 0.54	18-7 0.65	19-7 0.76	20-6 0.88	21-5 1.00	22-4 1.13
	13.7	10-0 0.12	11-7 0.18	12-11 0.25	14-2 0.33	15-4 0.42	16-5 0.51	17-5 0.61	18-4 0.71	19-3 0.82	20-1 0.93	20-11 1.05
	16.0	9-3 0.11	10-9 0.17	12-0 0.23	13-2 0.31	14-2 0.39	15-2 0.47	16-1 0.56	17-0 0.66	17-9 0.76	18-7 0.86	19-4 0.98
	19.2	8-6 0.10	9-10 0.15	10-11 0.21	12-0 0.28	12-11 0.35	13-10 0.43	14-8 0.51	15-6 0.60	16-3 0.69	17-0 0.79	17-8 0.89
	24.0	7-7 0.09	8-9 0.14	9-10 0.19	10-9 0.25	11-7 0.31	12-5 0.38	13-2 0.46	13-10 0.54	14-6 0.62	15-2 0.71	15-9 0.80

Note: The required modulus of elasticity, "E", in 1,000,000 pounds per square inch is shown below each span.

TABLE R-3 (cont.)

RAFTERS: Spans are measured along the horizontal projection and loads are considered as applied on the horizontal projection.

Extreme Fiber Stress in Bending, "F _b " (psi).											RAFTER SPACING SIZE (IN) (IN)		
1400	1500	1600	1700	1800	1900	2000	2100	2200	2400	2700			
11-4 1.26	11-9 1.40	12-1 1.54	12-6 1.68	12-10 1.83	13-2 1.99	13-6 2.15	13-10 2.31	14-2 2.48				12.0	
10-7 1.18	11-0 1.31	11-4 1.44	11-8 1.57	12-0 1.72	12-4 1.86	12-8 2.01	13-0 2.16	13-3 2.32				13.7	
9-10 1.09	10-2 1.21	10-6 1.33	10-10 1.46	11-1 1.59	11-5 1.72	11-9 1.86	12-0 2.00	12-4 2.15	12-10 2.45			16.0	2x6
8-11 0.99	9-3 1.10	9-7 1.22	9-10 1.33	10-2 1.45	10-5 1.57	10-8 1.70	11-0 1.83	11-3 1.96	11-9 2.23			19.2	
8-0 0.89	8-3 0.99	8-7 1.09	8-10 1.19	9-1 1.30	9-4 1.41	9-7 1.52	9-10 1.63	10-0 1.75	10-6 2.00	11-1 2.38		24.0	
14-11 1.26	15-5 1.40	16-0 1.54	16-5 1.68	16-11 1.83	17-5 1.99	17-10 2.15	18-3 2.31	18-9 2.48				12.0	2x8
14-0 1.18	14-6 1.31	14-11 1.44	15-5 1.57	15-10 1.72	16-3 1.86	16-8 2.01	17-1 2.16	17-6 2.32				13.7	
12-11 1.09	13-5 1.21	13-10 1.33	14-3 1.46	14-8 1.59	15-1 1.72	15-5 1.86	15-10 2.00	16-3 2.15	16-11 2.45			16.0	
11-10 0.99	12-3 1.10	12-7 1.22	13-0 1.33	13-5 1.45	13-9 1.57	14-1 1.70	14-6 1.83	14-10 1.96	15-5 2.23			19.2	
10-7 0.89	10-11 0.99	11-3 1.09	11-8 1.19	12-0 1.30	12-4 1.41	12-7 1.52	12-11 1.63	13-3 1.75	13-10 2.00	14-8 2.38		24.0	

19-1 1.26	19-9 1.40	20-4 1.54	21-0 1.68	21-7 1.83	22-2 1.99	22-9 2.15	23-4 2.31	23-11 2.48			12.0	2x10
17-10 1.18	18-5 1.31	19-1 1.44	19-8 1.57	20-2 1.72	20-9 1.86	21-4 2.01	21-10 2.16	22-4 2.32			13.7	
16-6 1.09	17-1 1.21	17-8 1.33	18-2 1.46	18-9 1.59	19-3 1.72	19-9 1.86	20-2 2.00	20-8 2.15	21-7 2.45		16.0	
15-1 0.99	15-7 1.10	16-1 1.22	16-7 1.33	17-1 1.45	17-7 1.57	18-0 1.70	18-5 1.83	18-11 1.96	19-9 2.23		19.2	
13-6 0.89	13-11 0.99	14-5 1.09	14-10 1.19	15-3 1.30	15-8 1.41	16-1 1.52	16-6 1.63	16-11 1.75	17-8 2.00	18-9 2.38	24.0	
23-2 1.26	24-0 1.40	24-9 1.54	25-6 1.68	26-3 1.83	27-0 1.99	27-8 2.15	28-5 2.31	29-1 2.48			12.0	2x12
21-8 1.18	22-5 1.31	23-2 1.44	23-11 1.57	24-7 1.72	25-3 1.86	25-11 2.01	26-7 2.16	27-2 2.32			13.7	
20-1 1.09	20-9 1.21	21-5 1.33	22-1 1.46	22-9 1.59	23-5 1.72	24-0 1.86	24-7 2.00	25-2 2.15	26-3 2.45		16.0	
18-4 0.99	19-0 1.10	19-7 1.22	20-2 1.33	20-9 1.45	21-4 1.57	21-11 1.70	22-5 1.83	23-0 1.96	24-0 2.23		19.2	
16-5 0.89	17-0 0.99	17-6 1.09	18-1 1.19	18-7 1.30	19-1 1.41	19-7 1.52	20-1 1.63	20-6 1.75	21-5 2.00	22-9 2.38	24.0	

Note: The required modulus of elasticity, "E", in 1,000,000 pounds per square inch is shown below each span.

TABLE R-5
FLAT OR SLOPED RAFTERS
 Supporting Plaster Ceiling
 (Flat roof or cathedral ceiling with no attic space)
 Live Load - 30 lb. per sq. ft.

Use in Zone 2

DESIGN CRITERIA:

Strength - 15 lbs. per sq. ft. dead load plus 30 lbs. per sq. ft. live load determines required fiber stress.

Deflection - For 30 lbs. per sq. ft. live load. Limited to Span in inches divided by 360.

RAFTER SIZE SPACING (IN) (IN)		Extreme Fiber Stress in Bending, "F _b " (psi).									
		300	400	500	600	700	890	900	1000	1100	1200
2x6	12.0	5-10	6-8	7-6	8-2	8-10	9-6	10-0	10-7	11-1	11-7
		0.19	0.29	0.41	0.54	0.68	0.83	0.99	1.15	1.33	1.52
	13.7	5-5	6-3	7-0	7-8	8-3	8-10	9-5	9-11	10-5	10-10
		0.18	0.27	0.38	0.50	0.63	0.77	0.92	1.08	1.25	1.42
	16.0	5-0	5-10	6-6	7-1	7-8	8-2	8-8	9-2	9-7	10-0
		0.16	0.25	0.35	0.46	0.59	0.72	0.85	1.00	1.15	1.31
19.2	4-7	5-4	5-11	6-6	7-0	7-6	7-11	8-4	8-9	9-2	
	0.15	0.23	0.32	0.42	0.53	0.65	0.78	0.91	1.05	1.20	
24.0	4-1	4-9	5-4	5-10	6-3	6-8	7-1	7-6	7-10	8-2	
	0.13	0.21	0.29	0.38	0.48	0.58	0.70	0.82	0.94	1.07	
2x8	12.0	7-8	8-10	9-10	10-10	11-8	12-6	13-3	13-11	14-8	15-3
		0.19	0.29	0.41	0.54	0.68	0.83	0.99	1.15	1.33	1.52
	13.7	7-2	8-3	9-3	10-1	10-11	11-8	12-5	13-1	13-8	14-4
		0.18	0.27	0.38	0.50	0.63	0.77	0.92	1.08	1.25	1.42
	16.0	6-7	7-8	8-7	9-4	10-1	10-10	11-6	12-1	12-8	13-3
		0.16	0.25	0.35	0.46	0.59	0.72	0.85	1.00	1.15	1.31
19.2	6-1	7-0	7-10	8-7	9-3	9-10	10-6	11-0	11-7	12-1	
	0.15	0.23	0.32	0.42	0.53	0.65	0.78	0.91	1.05	1.20	
24.0	5-5	6-3	7-0	7-8	8-3	8-10	9-4	9-10	10-4	10-10	
	0.13	0.21	0.29	0.38	0.48	0.58	0.70	0.82	0.94	1.07	

2x10	12.0	9-9 0.19	11-3 0.29	12-7 0.41	13-9 0.54	14-11 0.68	15-11 0.83	16-11 0.99	17-10 1.15	18-8 1.33	19-6 1.52
	13.7	9-1 0.18	10-6 0.27	11-9 0.38	12-11 0.50	13-11 0.63	14-11 0.77	15-10 0.92	16-8 1.08	17-6 1.25	18-3 1.42
	16.0	8-5 0.16	9-9 0.25	10-11 0.35	11-11 0.46	12-11 0.59	13-9 0.72	14-8 0.85	15-5 1.00	16-2 1.15	16-11 1.31
	19.2	7-8 0.15	8-11 0.23	9-11 0.32	10-11 0.42	11-9 0.53	12-7 0.65	13-4 0.78	14-1 0.91	14-9 1.05	15-5 1.20
	24.0	6-11 0.13	8-0 0.21	8-11 0.29	9-9 0.38	10-6 0.48	11-3 0.58	11-11 0.70	12-7 0.82	13-2 0.94	13-9 1.07
2x12	12.0	11-10 0.19	13-8 0.29	15-4 0.41	16-9 0.54	18-1 0.68	19-4 0.83	20-6 0.99	21-8 1.15	22-8 1.33	23-9 1.52
	13.7	11-1 0.18	12-10 0.27	14-4 0.38	15-8 0.50	16-11 0.63	18-1 0.77	19-3 0.92	20-3 1.08	21-3 1.25	22-2 1.42
	16.0	10-3 0.16	11-10 0.25	13-3 0.35	14-6 0.46	15-8 0.59	16-9 0.72	17-9 0.85	18-9 1.00	19-8 1.15	20-6 1.31
	19.2	9-5 0.15	10-10 0.23	12-1 0.32	13-3 0.42	14-4 0.53	15-4 0.65	16-3 0.78	17-1 0.91	17-11 1.05	18-9 1.20
	24.0	8-5 0.13	9-8 0.21	10-10 0.29	11-10 0.38	12-10 0.48	13-8 0.58	14-6 0.70	15-4 0.82	16-1 0.94	16-9 1.07

Note: The required modulus of elasticity, "E", in 1,000,000 pounds per square inch is shown below each span.

TABLE R-5 (cont.)

RAFTERS: Spans are measured along the horizontal projection and loads are considered as applied on the horizontal projection.

Extreme Fiber Stress in Bending, "F _b " (psi).									RAFTER SPACING SIZE (IN) (IN)	
1300	1400	1500	1600	1700	1800	1900	2000	2100		
12-1 1.71	12-6 1.91	13-0 2.12	13-5 2.34	13-10 2.56					12.0	2x6
11-3 1.60	11-9 1.79	12-2 1.98	12-6 2.19	12-11 2.39					13.7	
10-5 1.48	10-10 1.66	11-3 1.84	11-7 2.02	11-11 2.22	12-4 2.41				16.0	
9-6 1.35	9-11 1.51	10-3 1.68	10-7 1.85	10-11 2.02	11-3 2.20	11-6 2.39	11-10 2.58		19.2	
8-6 1.21	8-10 1.35	9-2 1.50	9-6 1.65	9-9 1.81	10-0 1.97	10-4 2.14	10-7 2.31	10-10 2.48	24.0	
15-11 1.71	16-6 1.91	17-1 2.12	17-8 2.34	18-2 2.56					12.0	
14-11 1.60	15-5 1.79	16-0 1.98	16-6 2.19	17-0 2.39					13.7	
13-9 1.48	14-4 1.66	14-10 1.84	15-3 2.02	15-9 2.22	16-3 2.41				16.0	
12-7 1.35	13-1 1.51	13-6 1.68	13-11 1.85	14-5 2.02	14-10 2.20	15-2 2.39	15-7 2.58		19.2	
11-3 1.21	11-8 1.35	12-1 1.50	12-6 1.65	12-10 1.81	13-3 1.97	13-7 2.14	13-11 2.31	14-4 2.48	24.0	

20-4 1.71	21-1 1.91	21-10 2.12	22-6 2.34	23-3 2.56					12.0	2x10
19-0 1.60	19-8 1.79	20-5 1.98	21-1 2.19	21-9 2.39					13.7	
17-7 1.48	18-3 1.66	18-11 1.84	19-6 2.02	20-1 2.22	20-8 2.41				16.0	
16-1 1.35	16-8 1.51	17-3 1.68	17-10 1.85	18-4 2.02	18-11 2.20	19-5 2.39	19-11 2.58		19.2	
14-4 1.21	14-11 1.35	15-5 1.50	15-11 1.65	16-5 1.81	16-11 1.97	17-4 2.14	17-10 2.31	18-3 2.48	24.0	
24-8 1.71	25-7 1.91	26-6 2.12	27-5 2.34	28-3 2.56					12.0	2x12
23-1 1.60	24-0 1.79	24-10 1.98	25-7 2.19	26-5 2.39					13.7	
21-5 1.48	22-2 1.66	23-0 1.84	23-9 2.02	24-5 2.22	25-2 2.41				16.0	
19-6 1.35	20-3 1.51	21-0 1.68	21-8 1.85	22-4 2.02	23-0 2.20	23-7 2.39	24-2 2.58		19.2	
17-5 1.21	18-1 1.35	18-9 1.50	19-4 1.65	20-0 1.81	20-6 1.97	21-1 2.14	21-8 2.31	22-2 2.48	24.0	

Note: The required modulus of elasticity, "E", in 1,000,000 pounds per square inch is shown below each span.

TABLE R-6
 FLAT OR SLOPED RAFTERS
 Supporting Plaster Ceiling
 (Flat roof or cathedral ceiling with no attic space)
 Live Load - 40 lb. per sq. ft.

Use in Zone 1

DESIGN CRITERIA:

Strength - 15 lbs. per sq. ft. dead load plus 40
 lbs. per sq. ft. live load determines required
 fiber stress.

Deflection - For 40 lbs. per sq. ft. live load.
 Limited to span in inches divided by 360.

RAFTER SIZE SPACING (IN) (IN)	Extreme Fiber Stress in Bending, "F _b " (psi).										
	300	400	500	600	700	800	900	1000	1100	1200	
2x6	12.0	5-3 0.19	6-1 0.29	6-9 0.40	7-5 0.53	8-0 0.67	8-7 0.82	9-1 0.97	9-7 1.14	10-0 1.31	10-6 1.50
	13.7	4-11 0.18	5-8 0.27	6-4 0.38	6-11 0.50	7-6 0.62	8-0 0.76	8-6 0.91	8-11 1.07	9-5 1.23	9-10 1.40
	16.0	4-6 0.16	5-3 0.25	5-10 0.35	6-5 0.46	6-11 0.58	7-5 0.71	7-10 0.84	8-3 0.99	8-8 1.14	9-1 1.30
	19.2	4-2 0.15	4-9 0.23	5-4 0.32	5-10 0.42	6-4 0.53	6-9 0.64	7-2 0.77	7-7 0.90	7-11 1.04	8-3 1.18
	24.0	3-8 0.13	4-3 0.20	4-9 0.28	5-3 0.37	5-8 0.47	6-1 0.58	6-5 0.69	6-9 0.81	7-1 0.93	7-5 1.06
2x8	12.0	6-11 0.19	8-0 0.29	8-11 0.40	9-9 0.53	10-7 0.67	11-3 0.82	12-0 0.97	12-7 1.14	13-3 1.31	13-10 1.50
	13.7	6-6 0.18	7-6 0.27	8-4 0.38	9-2 0.50	9-11 0.62	10-7 0.76	11-2 0.91	11-10 1.07	12-5 1.23	12-11 1.40
	16.0	6-0 0.16	6-11 0.25	7-9 0.35	8-6 0.46	9-2 0.58	9-9 0.71	10-4 0.84	10-11 0.99	11-6 1.14	12-0 1.30
	19.2	5-6 0.15	6-4 0.23	7-1 0.32	7-9 0.42	8-4 0.53	8-11 0.64	9-6 0.77	10-0 0.90	10-6 1.04	10-11 1.18
	24.0	4-11 0.13	5-8 0.20	6-4 0.28	6-11 0.37	7-6 0.47	8-0 0.58	8-6 0.69	8-11 0.81	9-4 0.93	9-9 1.06

2x10	12.0	8-10 0.19	10-2 0.29	11-5 0.40	12-6 0.53	13-6 0.67	14-5 0.82	15-3 0.97	16-1 1.14	16-11 1.31	17-8 1.50
	13.7	8-3 0.18	9-6 0.27	10-8 0.38	11-8 0.50	12-7 0.62	13-6 0.76	14-3 0.91	15-1 1.07	15-10 1.23	16-6 1.40
	16.0	7-8 0.16	8-10 0.25	9-10 0.35	10-10 0.46	11-8 0.58	12-6 0.71	13-3 0.84	13-11 0.99	14-8 1.14	15-3 1.30
	19.2	7-0 0.15	8-1 0.23	9-0 0.32	9-10 0.42	10-8 0.53	11-5 0.64	12-1 0.77	12-9 0.90	13-4 1.04	13-11 1.18
	24.0	6-3 0.13	7-2 0.20	8-1 0.28	8-10 0.37	9-6 0.47	10-2 0.58	10-10 0.69	11-5 0.81	11-11 0.93	12-6 1.06
	12.0	10-9 0.19	12-5 0.29	13-10 0.40	15-2 0.53	16-5 0.67	17-6 0.82	18-7 0.97	19-7 1.14	20-6 1.31	21-5 1.50
2x12	13.7	10-0 0.18	11-7 0.27	12-11 0.38	14-2 0.50	15-4 0.62	16-5 0.76	17-5 0.91	18-4 1.07	19-3 1.23	20-1 1.40
	16.0	9-3 0.16	10-9 0.25	12-0 0.35	13-2 0.46	14-2 0.58	15-2 0.71	16-1 0.84	17-0 0.99	17-9 1.14	18-7 1.30
	19.2	8-6 0.15	9-10 0.23	10-11 0.32	12-0 0.42	12-11 0.53	13-10 0.64	14-8 0.77	15-6 0.90	16-3 1.04	17-0 1.18
	24.0	7-7 0.13	8-9 0.20	9-10 0.28	10-9 0.37	11-7 0.47	12-5 0.58	13-2 0.69	13-10 0.81	14-6 0.93	15-2 1.06

Note: The required modulus of elasticity, "E", in 1,000,000 pounds per square inch is shown below each span.

TABLE R-6 (cont.)

RAFTERS: Spans are measured along the horizontal projection and loads are considered as applied on the horizontal projection.

Extreme Fiber Stress in Bending, "F _b " (psi).									RAFTER SPACING SIZE (IN)	
1300	1400	1500	1600	1700	1800	1900	2000	2100	(IN)	(IN)
10-11 1.69	11-4 1.89	11-9 2.09	12-1 2.31	12-6 2.53					12.0	2x6
10-3 1.58	10-7 1.77	11-0 1.96	11-4 2.16	11-8 2.36	12-0 2.57				13.7	
9-5 1.46	9-10 1.63	10-2 1.81	10-6 2.00	10-10 2.19	11-1 2.38	11-5 2.58			16.0	
8-8 1.34	8-11 1.49	9-3 1.65	9-7 1.82	9-10 2.00	10-2 2.18	10-5 2.36	10-8 2.55		19.2	
7-9 1.19	8-0 1.33	8-3 1.48	8-7 1.63	8-10 1.79	9-1 1.95	9-4 2.11	9-7 2.28	9-10 2.45	24.0	
14-5 1.69	14-11 1.89	15-5 2.09	16-0 2.31	16-5 2.53					12.0	
13-6 1.58	14-0 1.77	14-6 1.96	14-11 2.16	15-5 2.36	15-10 2.57				13.7	
12-6 1.46	12-11 1.63	13-5 1.81	13-10 2.00	14-3 2.19	14-8 2.38	15-1 2.58			16.0	
11-5 1.34	11-10 1.49	12-3 1.65	12-7 1.82	13-0 2.00	13-5 2.18	13-9 2.36	14-1 2.55		19.2	
10-2 1.19	10-7 1.33	10-11 1.48	11-3 1.63	11-8 1.79	12-0 1.95	12-4 2.11	12-7 2.28	12-11 2.45	24.0	

18-4 1.69	19-1 1.89	19-9 2.09	20-4 2.31	21-0 2.53					12.0	2x10
17-2 1.58	17-10 1.77	18-5 1.96	19-1 2.16	19-8 2.36	20-2 2.57				13.7	
15-11 1.46	16-6 1.63	17-1 1.81	17-8 2.00	18-2 2.19	18-9 2.38	19-3 2.58			16.0	
14-6 1.34	15-1 1.49	15-7 1.65	16-1 1.82	16-7 2.00	17-1 2.18	17-7 2.36	18-0 2.55		19.2	
13-0 1.19	13-6 1.33	13-11 1.48	14-5 1.63	14-10 1.79	15-3 1.95	15-8 2.11	16-1 2.28	16-6 2.45	24.0	
22-4 1.69	23-2 1.89	24-0 2.09	24-9 2.31	25-6 2.53					12.0	2x12
20-11 1.58	21-8 1.77	22-5 1.96	23-2 2.16	23-11 2.36	24-7 2.57				13.7	
19-4 1.46	20-1 1.63	20-9 1.81	21-5 2.00	22-1 2.19	22-9 2.38	23-5 2.58			16.0	
17-8 1.34	18-4 1.49	19-0 1.65	19-7 1.82	20-2 2.00	20-9 2.18	21-4 2.36	21-11 2.55		19.2	
15-9 1.19	16-5 1.33	17-0 1.48	17-6 1.63	18-1 1.79	18-7 1.95	19-1 2.11	19-7 2.28	20-1 2.45	24.0	

Note: The required modulus of elasticity, "E", in 1,000,000 pounds per square inch is shown below each span.

TABLE R-8
FLAT OR LOW SLOPE RAFTERS
 No Ceiling Load
 Slope 3 in 12 or less
 Live Load - 30 lb. per sq. ft.
 Use in Zone 2

DESIGN CRITERIA:
 Strength - 10 lbs. per sq. ft. dead load plus 30 lbs. per sq. ft. live load determines required fiber stress.
 Deflection - For 30 lbs. per sq. ft. live load. Limited to span in inches divided by 240.

RAFTER SIZE SPACING (IN)		Extreme Fiber Stress In Bending, "F _b " (psi).										
		300	400	500	600	700	800	900	1000	1100	1200	1300
2x6	12.0	6-2 0.15	7-1 0.23	7-11 0.32	8-8 0.43	9-5 0.54	10-0 0.66	10-8 0.78	11-3 0.92	11-9 1.06	12-4 1.21	12-10 1.36
	13.7	5-9 0.14	6-8 0.22	7-5 0.30	8-2 0.40	8-9 0.50	9-5 0.61	10-0 0.73	10-6 0.86	11-0 0.99	11-6 1.13	12-0 1.27
	16.0	5-4 0.13	6-2 0.20	6-11 0.28	7-6 0.37	8-2 0.47	8-8 0.57	9-3 0.68	9-9 0.80	10-2 0.92	10-8 1.05	11-1 1.18
	19.2	4-10 0.12	5-7 0.18	6-3 0.26	6-11 0.34	7-5 0.43	7-11 0.52	8-5 0.62	8-11 0.73	9-4 0.84	9-9 0.95	10-1 1.08
	24.0	4-4 0.11	5-0 0.16	5-7 0.23	6-2 0.30	6-8 0.38	7-1 0.46	7-6 0.55	7-11 0.65	8-4 0.75	8-8 0.85	9-1 0.96
2x8	12.0	8-1 0.15	9-4 0.23	10-6 0.32	11-6 0.43	12-5 0.54	13-3 0.66	14-0 0.78	14-10 0.92	15-6 1.06	16-3 1.21	16-10 1.36
	13.7	7-7 0.14	8-9 0.22	9-9 0.30	10-9 0.40	11-7 0.50	12-5 0.61	13-2 0.73	13-10 0.86	14-6 0.99	15-2 1.13	15-9 1.27
	16.0	7-0 0.13	8-1 0.20	9-1 0.28	9-11 0.37	10-9 0.47	11-6 0.57	12-2 0.68	12-10 0.80	13-5 0.92	14-0 1.05	14-7 1.18
	19.2	6-5 0.12	7-5 0.18	8-3 0.26	9-1 0.34	9-9 0.43	10-6 0.52	11-1 0.62	11-8 0.73	12-3 0.84	12-10 0.95	13-4 1.08
	24.0	5-9 0.11	6-7 0.16	7-5 0.23	8-1 0.30	8-9 0.38	9-4 0.46	9-11 0.55	10-6 0.65	11-0 0.75	11-6 0.85	11-11 0.96

2x10	12.0	10-4 0.15	11-11 0.23	13-4 0.32	14-8 0.43	15-10 0.54	16-11 0.66	17-11 0.78	18-11 0.92	19-10 1.06	20-8 1.21	21-6 1.36
	13.7	9-8 0.14	11-2 0.22	12-6 0.30	13-8 0.40	14-9 0.50	15-10 0.61	16-9 0.73	17-8 0.86	18-6 0.99	19-4 1.13	20-2 1.27
	16.0	8-11 0.13	10-4 0.20	11-7 0.28	12-8 0.37	13-8 0.47	14-8 0.57	15-6 0.68	16-4 0.80	17-2 0.92	17-11 1.05	18-8 1.18
	19.2	8-2 0.12	9-5 0.18	10-7 0.26	11-7 0.34	12-6 0.43	13-4 0.52	14-2 0.62	14-11 0.73	15-8 0.84	16-4 0.95	17-0 1.08
	24.0	7-4 0.11	8-5 0.16	9-5 0.23	10-4 0.30	11-2 0.38	11-11 0.46	12-8 0.55	13-4 0.65	14-0 0.75	14-8 0.85	15-3 0.96
2x12	12.0	12-7 0.15	14-6 0.23	16-3 0.32	17-9 0.43	19-3 0.54	20-6 0.66	21-9 0.78	23-0 0.92	24-1 1.06	25-2 1.21	26-2 1.36
	13.7	11-9 0.14	13-7 0.22	15-2 0.30	16-8 0.40	18-0 0.50	19-3 0.61	20-5 0.73	21-6 0.86	22-6 0.99	23-6 1.13	24-6 1.27
	16.0	10-11 0.13	12-7 0.20	14-1 0.28	15-5 0.37	16-8 0.47	17-9 0.57	18-10 0.68	19-11 0.80	20-10 0.92	21-9 1.05	22-8 1.18
	19.2	9-11 0.12	11-6 0.18	12-10 0.26	14-1 0.34	15-2 0.43	16-3 0.52	17-3 0.62	18-2 0.73	19-0 0.84	19-11 0.95	20-8 1.08
	24.0	8-11 0.11	10-3 0.16	11-6 0.23	12-7 0.30	13-7 0.38	14-6 0.46	15-5 0.55	16-3 0.65	17-0 0.75	17-9 0.85	18-6 0.96

Note: The required modulus of elasticity, "E", in 1,000,000 pounds per square inch is shown below each span.

TABLE R-8 (cont.)

RAFTERS: Spans are measured along the horizontal projection and loads are considered as applied on the horizontal projection.

Extreme Fiber Stress in Bending, "F _b " (psi).										RAFTER SPACING SIZE (IN)	
1400	1500	1600	1700	1800	1900	2000	2100	2200	2400		
13-3 1.52	13-9 1.69	14-2 1.86	14-8 2.04	15-1 2.22	15-6 2.41	15-11 2.60				12.0	2x6
12-5 1.42	12-10 1.58	13-3 1.74	13-8 1.90	14-1 2.08	14-6 2.25	14-10 2.43				13.7	
11-6 1.32	11-11 1.46	12-4 1.61	12-8 1.76	13-1 1.92	13-5 2.08	13-9 2.25	14-1 2.42	14-5 2.60		16.0	
10-6 1.20	10-10 1.33	11-3 1.47	11-7 1.61	11-11 1.75	12-3 1.90	12-7 2.05	12-10 2.21	13-2 2.37		19.2	
9-5 1.08	9-9 1.19	10-0 1.31	10-4 1.44	10-8 1.57	10-11 1.70	11-3 1.84	11-6 1.98	11-9 2.12	12-4 2.41	24.0	
17-6 1.52	18-2 1.69	18-9 1.86	19-4 2.04	19-10 2.22	20-5 2.41	20-11 2.60				12.0	
16-5 1.42	16-11 1.58	17-6 1.74	18-1 1.90	18-7 2.08	19-1 2.25	19-7 2.43				13.7	
15-2 1.32	15-8 1.46	16-3 1.61	16-9 1.76	17-2 1.92	17-8 2.08	18-2 2.25	18-7 2.42	19-0 2.60		16.0	
13-10 1.20	14-4 1.33	14-10 1.47	15-3 1.61	15-8 1.75	16-2 1.90	16-7 2.05	16-11 2.21	17-4 2.37		19.2	
12-5 1.08	12-10 1.19	13-3 1.31	13-8 1.44	14-0 1.57	14-5 1.70	14-10 1.84	15-2 1.98	15-6 2.12	16-3 2.41	24.0	

22-4 1.52	23-2 1.69	23-11 1.86	24-7 2.04	25-4 2.22	26-0 2.41	26-8 2.60				12.0	2x10
20-11 1.42	21-8 1.58	22-4 1.74	23-0 1.90	23-8 2.08	24-4 2.25	25-0 2.43				13.7	
19-4 1.32	20-0 1.46	20-8 1.61	21-4 1.76	21-11 1.92	22-6 2.08	23-2 2.25	23-8 2.42	24-3 2.60		16.0	
17-8 1.20	18-3 1.33	18-11 1.47	19-6 1.61	20-0 1.75	20-7 1.90	21-1 2.05	21-8 2.21	22-2 2.37		19.2	
15-10 1.08	16-4 1.19	16-11 1.31	17-5 1.44	17-11 1.57	18-5 1.70	18-11 1.84	19-4 1.98	19-10 2.12	20-8 2.41	24.0	
27-2 1.52	28-2 1.69	29-1 1.86	29-11 2.04	30-10 2.22	31-8 2.41	32-6 2.60				12.0	
25-5 1.42	26-4 1.58	27-2 1.74	28-0 1.90	28-10 2.08	29-7 2.25	30-5 2.43				13.7	
23-6 1.32	24-4 1.46	25-2 1.61	25-11 1.76	26-8 1.92	27-5 2.08	28-2 2.25	28-10 2.42	29-6 2.60		16.0	
21-6 1.20	22-3 1.33	23-0 1.47	23-8 1.61	24-4 1.75	25-0 1.90	25-8 2.05	26-4 2.21	26-11 2.37		19.2	
19-3 1.08	19-11 1.19	20-6 1.31	21-2 1.44	21-9 1.57	22-5 1.70	23-0 1.84	23-6 1.98	24-1 2.12	25-2 2.41	24.0	

Note: The required modulus of elasticity, "E", in 1,000,000 pounds per square inch is shown below each span.

**TABLE R-9
FLAT OR LOW SLOPE RAFTERS**

No Ceiling Load
Slope 3 in 12 or less
Live Load - 40 lbs. per sq. ft.
Use in Zone 1

DESIGN CRITERIA:
Strength - 10 lbs. per sq. ft. dead load plus 40 lbs. per sq. ft. live load determines required fiber stress.
Deflection - For 40 lbs. per sq. ft. live load, Limited to span in inches divided by 240.

RAFTER SIZE SPACING (IN) (IN)		Extreme Fiber Stress in Bending, "F _b " (psi)										
		300	400	500	600	700	800	900	1000	1100	1200	1300
2x6	12.0	5-6 0.14	6-4 0.22	7-1 0.31	7-9 0.41	8-5 0.51	9-0 0.63	9-6 0.75	10-0 0.88	10-6 1.01	11-0 1.15	11-5 1.30
	13.7	5-2 0.13	5-11 0.21	6-8 0.29	7-3 0.38	7-10 0.48	8-5 0.59	8-11 0.70	9-5 0.82	9-10 0.95	10-3 1.08	10-9 1.22
	16.0	4-9 0.12	5-6 0.19	6-2 0.27	6-9 0.35	7-3 0.44	7-9 0.54	8-3 0.65	8-8 0.76	9-1 0.88	9-6 1.00	9-11 1.12
	19.2	4-4 0.11	5-0 0.18	5-7 0.24	6-2 0.32	6-8 0.41	7-1 0.50	7-6 0.59	7-11 0.69	8-4 0.80	8-8 0.91	9-1 1.03
	24.0	3-11 0.10	4-6 0.16	5-0 0.22	5-6 0.29	5-11 0.36	6-4 0.44	6-9 0.53	7-1 0.62	7-5 0.71	7-9 0.81	8-1 0.92
2x8	12.0	7-3 0.14	8-4 0.22	9-4 0.31	10-3 0.41	11-1 0.51	11-10 0.63	12-7 0.75	13-3 0.88	13-11 1.01	14-6 1.15	15-1 1.30
	13.7	6-9 0.13	7-10 0.21	8-9 0.29	9-7 0.38	10-4 0.48	11-1 0.59	11-9 0.70	12-5 0.82	13-0 0.95	13-7 1.08	14-1 1.22
	16.0	6-3 0.12	7-3 0.19	8-1 0.27	8-11 0.35	9-7 0.44	10-3 0.54	10-11 0.65	11-6 0.76	12-0 0.88	12-7 1.00	13-1 1.12
	19.2	5-9 0.11	6-7 0.18	7-5 0.24	8-1 0.32	8-9 0.41	9-4 0.50	9-11 0.59	10-6 0.69	11-0 0.80	11-6 0.91	11-11 1.03
	24.0	5-2 0.10	5-11 0.16	6-7 0.22	7-3 0.29	7-10 0.36	8-4 0.44	8-11 0.53	9-4 0.62	9-10 0.71	10-3 0.81	10-8 0.92

2x10	12.0	9-3 0.14	10-8 0.22	11-11 0.31	13-1 0.41	14-2 0.51	15-1 0.63	16-0 0.75	16-11 0.88	17-9 1.01	18-6 1.15	19-3 1.30
	13.7	8-8 0.13	10-0 0.21	11-2 0.29	12-3 0.38	13-3 0.48	14-2 0.59	15-0 0.70	15-10 0.82	16-7 0.95	17-4 1.08	18-0 1.22
	16.0	8-0 0.12	9-3 0.19	10-4 0.27	11-4 0.35	12-3 0.44	13-1 0.54	13-11 0.65	14-8 0.76	15-4 0.88	16-0 1.00	16-8 1.12
	19.2	7-4 0.11	8-5 0.18	9-5 0.24	10-4 0.32	11-2 0.41	11-11 0.50	12-8 0.59	13-4 0.69	14-0 0.80	14-8 0.91	15-3 1.03
	24.0	6-6 0.10	7-7 0.16	8-5 0.22	9-3 0.29	10-0 0.36	10-8 0.44	11-4 0.53	11-11 0.62	12-6 0.71	13-1 0.81	13-7 0.92
2x12	12.0	11-3 0.14	13-0 0.22	14-6 0.31	15-11 0.41	17-2 0.51	18-4 0.63	19-6 0.75	20-6 0.88	21-7 1.01	22-6 1.15	23-5 1.30
	13.7	10-6 0.13	12-2 0.21	13-7 0.29	14-11 0.38	16-1 0.48	17-2 0.59	18-3 0.70	19-3 0.82	20-2 0.95	21-1 1.08	21-11 1.22
	16.0	9-9 0.12	11-3 0.19	12-7 0.27	13-9 0.35	14-11 0.44	15-11 0.54	16-11 0.65	17-9 0.76	18-8 0.88	19-6 1.00	20-3 1.12
	19.2	8-11 0.11	10-3 0.18	11-6 0.24	12-7 0.32	13-7 0.41	14-6 0.50	15-5 0.59	16-3 0.69	17-0 0.80	17-9 0.91	18-6 1.03
	24.0	7-11 0.10	9-2 0.16	10-3 0.22	11-3 0.29	12-2 0.36	13-0 0.44	13-9 0.53	14-6 0.62	15-3 0.71	15-11 0.81	16-7 0.92

Note: The required modulus of elasticity, "E", in 1,000,000 pounds per square inch is shown below each span.

TABLE R-9 (cont.)

RAFTERS: Spans are measured along the horizontal projection and loads are considered as applied on the horizontal projection.

Extreme Fiber Stress in Bending, "F _b " (psi).										RAFTER SPACING SIZE (IN)	RAFTER SPACING SIZE (IN)
1400	1500	1600	1700	1800	1900	2000	2100	2200	2400		
11-11 1.45	12-4 1.61	12-8 1.77	13-1 1.94	13-6 2.12	13-10 2.30	14-2 2.48				12.0	2x6
11-1 1.36	11-6 1.51	11-11 1.66	12-3 1.82	12-7 1.98	12-11 2.15	13-3 2.32	13-7 2.49			13.7	
10-3 1.26	10-8 1.39	11-0 1.54	11-4 1.68	11-8 1.83	12-0 1.99	12-4 2.15	12-7 2.31	12-11 2.48		16.0	
9-5 1.15	9-9 1.27	10-0 1.40	10-4 1.54	10-8 1.67	10-11 1.81	11-3 1.96	11-6 2.11	11-9 2.26	12-4 2.58	19.2	
8-5 1.03	8-8 1.14	9-0 1.25	9-3 1.37	9-6 1.50	9-9 1.62	10-0 1.75	10-3 1.89	10-6 2.02	11-0 2.30	24.0	
15-8 1.45	16-3 1.61	16-9 1.77	17-3 1.94	17-9 2.12	18-3 2.30	18-9 2.48				12.0	
14-8 1.36	15-2 1.51	15-8 1.66	16-2 1.82	16-7 1.98	17-1 2.15	17-6 2.32	17-11 2.49			13.7	
13-7 1.26	14-0 1.39	14-6 1.54	14-11 1.68	15-5 1.83	15-10 1.99	16-3 2.15	16-7 2.31	17-0 2.48		16.0	
12-5 1.15	12-10 1.27	13-3 1.40	13-8 1.54	14-0 1.67	14-5 1.81	14-10 1.96	15-2 2.11	15-6 2.26	16-3 2.58	19.2	
11-1 1.03	11-6 1.14	11-10 1.25	12-2 1.37	12-7 1.50	12-11 1.62	13-3 1.75	13-7 1.89	13-11 2.02	14-6 2.30	24.0	

20-0 1.45	20-8 1.61	21-4 1.77	22-0 1.94	22-8 2.12	23-3 2.30	23-11 2.48					12.0	2x10
18-8 1.36	19-4 1.51	20-0 1.66	20-7 1.82	21-2 1.98	21-9 2.15	22-4 2.32	22-11 2.49				13.7	
17-4 1.26	17-11 1.39	18-6 1.54	19-1 1.68	19-7 1.83	20-2 1.99	20-8 2.15	21-2 2.31	21-8 2.48			16.0	
15-10 1.15	16-4 1.27	16-11 1.40	17-5 1.54	17-11 1.67	18-5 1.81	18-11 1.96	19-4 2.11	19-10 2.26	20-8 2.58		19.2	
14-2 1.03	14-8 1.14	15-1 1.25	15-7 1.37	16-0 1.50	16-6 1.62	16-11 1.75	17-4 1.89	17-9 2.02	18-6 2.30		24.0	
24-4 1.45	25-2 1.61	26-0 1.77	26-9 1.94	27-7 2.12	28-4 2.30	29-1 2.48					12.0	2x12
22-9 1.36	23-6 1.51	24-4 1.66	25-1 1.82	25-9 1.98	26-6 2.15	27-2 2.32	27-10 2.49				13.7	
21-1 1.26	21-9 1.39	22-6 1.54	23-2 1.68	23-10 1.83	24-6 1.99	25-2 2.15	25-9 2.31	26-5 2.48			16.0	
19-3 1.15	19-11 1.27	20-6 1.40	21-2 1.54	21-9 1.67	22-5 1.81	23-0 1.96	23-6 2.11	24-1 2.26	25-2 2.58		19.2	
17-2 1.03	17-9 1.14	18-4 1.25	18-11 1.37	19-6 1.50	20-0 1.62	20-6 1.75	21-1 1.89	21-7 2.02	22-6 2.30		24.0	

Note: The required modulus of elasticity, "E", in 1,000,000 pounds per inch is shown below each span.

TABLE R-11
MEDIUM OR HIGH SLOPE RAFTERS
 No Ceiling Load
 Slope over 3 in 12
 Live Load - 30 lbs. per sq. ft.
 (Heavy roof covering)
 Use in Zone 2

DESIGN CRITERIA:
 Strength - 15 lbs. per sq. ft. dead load plus
 30 lbs. per sq. ft. live load determines
 required fiber stress.
 Deflection - For 30 lbs. per sq. ft. live load,
 Limited to span in inches divided by 180.

RAFTER SIZE SPACING (IN)	Extreme Fiber Stress in Bending, "F _b " (psi).												
	200	300	400	500	600	700	800	900	1000	1100	1200	1300	
12.0	3-0	3-8	4-3	4-9	5-3	5-8	6-0	6-5	6-9	7-1	7-5	7-8	
	0.05	0.09	0.15	0.20	0.27	0.34	0.41	0.49	0.58	0.67	0.76	0.86	
13.7	2-10	3-5	4-0	4-5	4-11	5-2	5-8	6-0	6-4	6-7	6-11	7-2	
	0.05	0.09	0.14	0.19	0.25	0.32	0.39	0.46	0.54	0.62	0.71	0.80	
16.0	2-7	3-2	3-8	4-1	4-6	4-11	5-3	5-6	5-10	6-1	6-5	6-8	
	0.04	0.08	0.13	0.18	0.23	0.29	0.36	0.43	0.50	0.58	0.66	0.74	
19.2	2-5	2-11	3-4	3-9	4-1	4-5	4-9	5-1	5-4	5-7	5-10	6-1	
	0.04	0.08	0.12	0.16	0.21	0.27	0.33	0.39	0.46	0.53	0.60	0.68	
24.0	2-2	2-7	3-0	3-4	3-8	4-0	4-3	4-6	4-9	5-0	5-3	5-5	
	0.04	0.07	0.10	0.14	0.19	0.24	0.29	0.35	0.41	0.47	0.54	0.61	
12.0	4-9	5-10	6-8	7-6	8-2	8-10	9-6	10-0	10-7	11-1	11-7	12-1	
	0.05	0.09	0.15	0.20	0.27	0.34	0.41	0.49	0.58	0.67	0.76	0.86	
13.7	4-5	5-5	6-3	7-0	7-8	8-3	8-10	9-5	9-11	10-5	10-10	11-3	
	0.05	0.09	0.14	0.19	0.25	0.32	0.39	0.46	0.54	0.62	0.71	0.80	
16.0	4-1	5-0	5-10	6-6	7-1	7-8	8-2	8-8	9-2	9-7	10-0	10-5	
	0.04	0.08	0.13	0.18	0.23	0.29	0.36	0.43	0.50	0.58	0.66	0.74	
19.2	3-9	4-7	5-4	5-11	6-6	7-0	7-6	7-11	8-4	8-9	9-2	9-6	
	0.04	0.08	0.12	0.16	0.21	0.27	0.33	0.39	0.46	0.53	0.60	0.68	
24.0	3-4	4-1	4-9	5-4	5-10	6-3	6-8	7-1	7-6	7-10	8-2	8-6	
	0.04	0.07	0.10	0.14	0.19	0.24	0.29	0.35	0.41	0.47	0.54	0.61	

	12.0	5-3	7-8	8-10	9-10	10-10	11-8	12-6	13-3	13-11	14-8	15-3	15-11
		0.05	0.09	0.15	0.20	0.27	0.34	0.41	0.49	0.58	0.67	0.76	0.86
	13.7	5-10	7-2	8-3	9-3	10-1	10-11	11-8	12-5	13-1	13-8	14-4	14-11
		0.05	0.08	0.14	0.19	0.25	0.32	0.39	0.46	0.54	0.62	0.71	0.80
2x8	16.0	5-5	6-7	7-8	8-7	9-4	10-1	10-10	11-6	12-1	12-8	13-3	13-9
		0.04	0.08	0.13	0.18	0.23	0.29	0.36	0.43	0.50	0.58	0.66	0.74
	19.2	4-11	6-1	7-0	7-10	8-7	9-3	9-10	10-6	11-0	11-7	12-1	12-7
		0.04	0.08	0.12	0.16	0.21	0.27	0.33	0.39	0.46	0.53	0.60	0.68
	24.0	4-5	5-5	6-3	7-0	7-8	8-3	8-10	9-4	9-10	10-4	10-10	11-3
		0.04	0.07	0.10	0.14	0.19	0.24	0.29	0.35	0.41	0.47	0.54	0.61
	12.0	8-0	9-9	11-3	12-7	13-9	14-11	15-11	16-11	17-10	18-8	19-6	20-4
		0.05	0.09	0.15	0.20	0.27	0.34	0.41	0.49	0.58	0.67	0.76	0.86
	13.7	7-5	9-1	10-6	11-9	12-11	13-11	14-11	15-10	16-8	17-6	18-3	19-0
		0.05	0.09	0.14	0.19	0.25	0.32	0.39	0.46	0.54	0.62	0.71	0.80
2x10	16.0	6-11	8-5	9-9	10-11	11-11	12-11	13-9	14-8	15-5	16-2	16-11	17-7
		0.04	0.08	0.13	0.18	0.23	0.29	0.36	0.43	0.50	0.58	0.66	0.74
	19.2	6-4	7-8	8-11	9-11	10-11	11-9	12-7	13-4	14-1	14-9	15-5	16-1
		0.04	0.08	0.12	0.16	0.21	0.27	0.33	0.39	0.46	0.53	0.60	0.68
	24.0	5-8	6-11	8-0	8-11	9-9	10-6	11-3	11-11	12-7	13-2	13-9	14-4
		0.04	0.07	0.10	0.14	0.19	0.24	0.29	0.35	0.41	0.47	0.54	0.61

Note: The required modulus of elasticity, "E", in 1,000,000 pounds per inch is shown below each span.

TABLE R-11 (cont.)

RAFTERS: Spans are measured along the horizontal projection and loads are considered as applied on the horizontal projection.

Extreme Fiber Stress in Bending, "F _b " (psi).												RAFTER SPACING SIZE (IN)	
1400	1500	1600	1700	1800	1900	2000	2100	2200	2400	2700	3000	(IN)	(IN)
8-0 0.96	8-3 1.06	8-6 1.17	8-9 1.28	9-0 1.39	9-3 1.51	9-6 1.63	9-9 1.76	10-0 1.88	10-5 2.15	11-1 2.56		12.0	
7-5 0.89	7-8 0.99	8-0 1.09	8-3 1.20	8-5 1.30	8-8 1.41	8-11 1.53	9-2 1.64	9-4 1.76	9-9 2.01	10-4 2.40		13.7	
6-11 0.83	7-2 0.92	7-5 1.01	7-7 1.11	7-10 1.21	8-0 1.31	8-3 1.41	8-5 1.52	8-8 1.63	9-0 1.86	9-7 2.22	10-1 2.60	16.0	2x4
6-4 0.76	6-6 0.84	6-9 0.92	6-11 1.01	7-2 1.10	7-4 1.20	7-6 1.29	7-9 1.39	7-11 1.49	8-3 1.70	8-9 2.03	9-3 2.37	19.2	
5-8 0.68	5-10 0.75	6-0 0.83	6-3 0.90	6-5 0.99	6-7 1.07	6-9 1.15	6-11 1.24	7-1 1.33	7-5 1.52	7-10 1.81	8-3 2.12	24.0	
12-6 0.96	13-0 1.06	13-5 1.17	13-10 1.28	14-2 1.39	14-7 1.51	15-0 1.63	15-4 1.76	15-8 1.88	16-5 2.15	17-5 2.56		12.0	
11-9 0.89	12-2 0.99	12-6 1.09	12-11 1.20	13-3 1.30	13-8 1.41	14-0 1.53	14-4 1.64	14-8 1.76	15-4 2.01	16-3 2.40		13.7	
10-10 0.83	11-3 0.92	11-7 1.01	11-11 1.11	12-4 1.21	12-8 1.31	13-0 1.41	13-3 1.52	13-7 1.63	14-2 1.86	15-1 2.22	15-11 2.60	16.0	2x6
9-11 0.76	10-3 0.84	10-7 0.92	10-11 1.01	11-3 1.10	11-6 1.20	11-10 1.29	12-2 1.39	12-5 1.49	13-0 1.70	13-9 2.03	14-6 2.37	19.2	
8-10 0.68	9-2 0.75	9-6 0.83	9-9 0.90	10-0 0.99	10-4 1.07	10-7 1.15	10-10 1.24	11-1 1.33	11-7 1.52	12-4 1.81	13-0 2.12	24.0	

16-6 0.96	17-1 1.06	17-8 1.17	18-2 1.28	18-9 1.39	19-3 1.51	19-9 1.63	20-3 1.76	20-8 1.88	21-7 2.15	22-11 2.56		12.0	2x8
15-5 0.89	16-0 0.99	16-6 1.09	17-0 1.20	17-6 1.30	18-0 1.41	18-5 1.53	18-11 1.64	19-4 1.76	20-8 2.01	21-5 2.40		13.7	
14-4 0.83	14-10 0.92	15-3 1.01	15-9 1.11	16-3 1.21	16-8 1.31	17-1 1.41	17-6 1.52	17-11 1.63	18-9 1.86	19-10 2.22	20-11 2.60	16.0	
13-1 0.76	13-6 0.84	13-11 0.92	14-5 1.01	14-10 1.10	15-2 1.20	15-7 1.29	16-0 1.39	16-4 1.49	17-1 1.70	18-2 2.03	19-1 2.37	19.2	
11-8 0.68	12-1 0.75	12-6 0.83	12-10 0.90	13-3 0.99	13-7 1.07	13-11 1.15	14-4 1.24	14-8 1.33	15-3 1.52	16-3 1.81	17-1 2.12	24.0	2x10
21-1 0.96	21-10 1.06	22-6 1.17	23-3 1.28	23-11 1.39	24-6 1.51	25-2 1.63	25-10 1.76	26-5 1.88	27-7 2.15	29-3 2.56		12.0	
19-8 0.89	20-5 0.99	21-1 1.09	21-9 1.20	22-4 1.30	22-11 1.41	23-7 1.53	24-2 1.64	24-8 1.76	25-10 2.01	27-4 2.40		13.7	
18-3 0.83	18-11 0.92	19-6 1.01	20-1 1.11	20-8 1.21	21-3 1.31	21-10 1.41	22-4 1.52	22-10 1.63	23-11 1.86	25-4 2.22	26-8 2.60	16.0	
16-8 0.76	17-3 0.84	17-10 0.92	18-4 1.01	18-11 1.10	19-5 1.20	19-11 1.29	20-5 1.39	20-10 1.49	21-10 1.70	23-2 2.03	24-5 2.37	19.2	2x10
14-11 0.68	15-5 0.75	15-11 0.83	16-5 0.90	16-11 0.99	17-4 1.07	17-10 1.15	18-3 1.24	18-8 1.33	19-6 1.52	20-8 1.81	21-10 2.12	24.0	

Note: The required modulus of elasticity, "E", in 1,000,000 pounds per square inch is shown below each span.

TABLE R-12
MEDIUM OR HIGH SLOPE RAFTERS

No Ceiling Load
Slope over 3 in 12
Live Load - 40 lbs. per sq. ft.
(Heavy roof covering)
Use in Zone I

DESIGN CRITERIA:

Strength - 15 lbs. per sq. ft. dead load plus 40 lbs. per sq. ft. live load determines required fiber stress.
Deflection - For 40 lbs. per sq. ft. live load. Limited to span in inches divided by 180.

RAFTER SIZE SPACING (IN)	Extreme Fiber Stress in Bending, "F _b " (psi)											
	200	300	400	500	600	700	800	900	1000	1100	1200	1300
12.0	2.9	3.4	3.10	4.4	4.9	5.1	5.5	5.9	6.1	6.5	6.8	6.11
	0.05	0.09	0.14	0.20	0.26	0.33	0.41	0.49	0.57	0.66	0.75	0.84
	2.7	3.1	3.7	4.0	4.5	4.9	5.1	5.5	5.8	6.0	6.3	6.6
13.7	0.05	0.09	0.13	0.19	0.25	0.31	0.38	0.46	0.53	0.61	0.70	0.79
	2.4	2.11	3.4	3.9	4.1	4.5	4.9	5.0	5.3	5.6	5.9	6.0
	0.04	0.08	0.12	0.17	0.23	0.29	0.35	0.42	0.49	0.57	0.65	0.73
16.0	2.2	2.8	3.1	3.5	3.9	4.0	4.4	4.7	4.10	5.1	5.3	5.6
	0.04	0.07	0.11	0.16	0.21	0.26	0.32	0.38	0.45	0.52	0.59	0.67
	1.11	2.4	2.9	3.1	3.4	3.7	3.10	4.1	4.4	4.8	4.9	4.11
19.2	0.04	0.07	0.10	0.14	0.19	0.24	0.29	0.34	0.40	0.46	0.53	0.60
	4.3	5.3	6.1	6.8	7.5	8.0	8.7	9.1	9.7	10.0	10.6	10.11
	0.05	0.09	0.14	0.20	0.26	0.33	0.41	0.49	0.57	0.66	0.75	0.84
13.7	4.0	4.11	5.8	6.4	6.11	7.6	8.0	8.6	8.11	9.5	8.10	10.3
	0.05	0.09	0.13	0.19	0.25	0.31	0.38	0.46	0.53	0.61	0.70	0.79
	3.8	4.6	5.3	5.70	6.5	6.11	7.5	7.10	8.3	8.9	9.1	9.5
16.0	0.04	0.08	0.12	0.17	0.23	0.29	0.35	0.42	0.49	0.57	0.65	0.73
	3.5	4.2	4.9	5.4	5.10	6.4	6.9	7.2	7.7	7.11	8.3	8.8
	0.04	0.07	0.11	0.16	0.21	0.26	0.32	0.38	0.45	0.52	0.59	0.67
19.2	3.0	3.8	4.3	4.9	5.3	5.8	6.1	6.5	6.9	7.1	7.5	7.9
	0.04	0.07	0.10	0.14	0.19	0.24	0.29	0.34	0.40	0.46	0.53	0.60
	2.4.0	0.04	0.07	0.10	0.14	0.19	0.24	0.29	0.34	0.40	0.46	0.53

	12.0	5-8	6-11	8-0	8-11	9-9	10-7	11-3	12-0	12-7	13-3	13-10	14-5
		0.05	0.09	0.14	0.20	0.26	0.33	0.41	0.49	0.57	0.66	0.75	0.84
	13.7	5-3	6-6	7-6	8-4	9-2	9-11	10-7	11-2	11-10	12-5	12-11	13-6
		0.05	0.09	0.13	0.19	0.25	0.31	0.38	0.46	0.52	0.61	0.70	0.79
2x8	16.0	4-11	6-0	6-11	7-9	8-6	9-2	9-9	10-4	10-11	11-6	12-0	12-6
		0.04	0.08	0.12	0.17	0.23	0.29	0.35	0.42	0.49	0.57	0.65	0.73
	19.2	4-6	5-6	6-4	7-1	7-9	8-4	8-11	9-6	10-0	10-6	10-11	11-5
		0.04	0.07	0.11	0.16	0.21	0.26	0.32	0.38	0.45	0.52	0.59	0.67
24.0	4-0	4-11	5-8	6-4	6-11	7-6	8-0	8-6	8-11	9-4	9-9	10-2	10-2
	0.04	0.07	0.10	0.14	0.19	0.24	0.29	0.34	0.40	0.46	0.53	0.60	0.60
12.0	7-2	8-10	10-2	11-5	12-6	13-6	14-5	15-3	16-1	16-11	17-8	18-4	18-4
	0.05	0.09	0.14	0.20	0.26	0.33	0.41	0.49	0.57	0.66	0.75	0.84	0.84
	13.7	6-9	8-3	9-6	10-8	11-8	12-7	13-8	14-3	15-1	15-10	16-6	17-2
	0.05	0.09	0.13	0.19	0.25	0.31	0.38	0.46	0.52	0.61	0.70	0.79	0.79
16.0	6-3	7-8	8-10	9-10	10-10	11-8	12-8	13-5	14-3	15-11	15-3	15-11	15-11
	0.04	0.08	0.12	0.17	0.23	0.29	0.35	0.42	0.49	0.57	0.65	0.73	0.73
19.2	5-8	7-0	8-1	9-0	9-10	10-8	11-5	12-1	12-9	13-4	13-11	14-6	14-6
	0.04	0.07	0.11	0.16	0.21	0.26	0.32	0.38	0.45	0.52	0.59	0.67	0.67
24.0	5-1	6-3	7-2	8-1	8-10	9-6	10-2	10-10	11-5	11-11	12-6	13-0	13-0
	0.04	0.07	0.10	0.14	0.19	0.24	0.29	0.34	0.40	0.46	0.53	0.60	0.60

Note: The required modulus of elasticity, "E", in 1,000,000 pounds per square inch is shown below each span.

TABLE R-12 (cont.)

RAFTERS: Spans are measured along the horizontal projection and loads are considered as applied on the horizontal projection.

Extreme Fiber Stress in Bending, "F _b " (psi).												RAFTER SPACING SIZE (IN) (IN)	
1400	1500	1600	1700	1800	1900	2000	2100	2200	2400	2700	3000		
7-3 0.94	7-6 1.05	7-8 1.15	7-11 1.26	8-2 1.38	8-5 1.49	8-7 1.61	8-10 1.73	9-0 1.86	9-5 2.12	10-0 2.53			12.0
6-9 0.88	7-0 0.98	7-3 1.08	7-5 1.18	7-8 1.29	7-10 1.40	8-1 1.51	8-3 1.62	8-5 1.74	8-10 1.98	9-4 2.36			13.7
6-3 0.82	6-6 0.91	6-8 1.00	6-11 1.09	7-1 1.19	7-3 1.29	7-6 1.40	7-8 1.50	7-10 1.61	8-2 1.83	8-8 2.19	9-2 2.56		16.0 2x4
5-8 0.75	5-11 0.83	6-1 0.91	6-3 1.00	6-6 1.09	6-8 1.18	6-10 1.27	7-0 1.37	7-2 1.47	7-6 1.67	7-11 2.00	8-4 2.34		19.2
5-1 0.67	5-3 0.74	5-5 0.82	5-7 0.89	5-9 0.97	5-11 1.05	6-1 1.14	6-3 1.23	6-5 1.31	6-8 1.50	7-1 1.79	7-6 2.09		24.0
11-4 0.94	11-9 1.05	12-1 1.15	12-6 1.26	12-10 1.38	13-2 1.49	13-6 1.61	13-10 1.73	14-2 1.86	14-10 2.12	15-9 2.53			12.0
10-7 0.88	11-0 0.98	11-4 1.08	11-8 1.18	12-0 1.29	12-4 1.40	12-8 1.51	13-0 1.62	13-3 1.74	13-10 1.98	14-9 2.36			13.7
9-10 0.82	10-2 0.91	10-6 1.00	10-10 1.09	11-1 1.19	11-5 1.29	11-9 1.40	12-0 1.50	12-4 1.61	12-10 1.83	13-7 2.19	14-4 2.56		16.0 2x6
8-11 0.75	9-3 0.83	9-7 0.91	9-10 1.00	10-2 1.09	10-5 1.18	10-8 1.27	11-0 1.37	11-3 1.47	11-9 1.67	12-5 2.00	13-1 2.34		19.2
8-0 0.67	8-3 0.74	8-7 0.82	8-10 0.89	9-1 0.97	9-4 1.06	9-7 1.14	9-10 1.23	10-0 1.31	10-6 1.50	11-1 1.79	11-9 2.09		24.0

14-11	15-5	16-0	16-5	16-11	17-5	17-10	18-3	18-9	19-7	20-9		
0.94	1.05	1.15	1.26	1.38	1.49	1.61	1.73	1.86	2.12	2.53		12.0
14-0	14-6	14-11	15-5	15-10	16-3	16-8	17-1	17-6	18-3	19-5		
0.88	0.98	1.08	1.18	1.29	1.40	1.51	1.62	1.74	1.98	2.36		13.7
12-11	13-5	13-10	14-3	14-8	15-1	15-5	15-10	16-3	16-11	18-0		2x8
0.82	0.91	1.00	1.09	1.19	1.29	1.40	1.50	1.61	1.83	2.19		16.0
11-10	12-3	12-7	13-0	13-5	13-9	14-1	14-6	14-10	15-5	16-5		17.3
0.75	0.83	0.91	1.00	1.08	1.18	1.27	1.37	1.47	1.67	2.00		19.2
10-7	10-11	11-3	11-8	12-0	12-4	12-7	12-11	13-3	13-10	14-8		15-5
0.67	0.74	0.82	0.89	0.97	1.06	1.14	1.23	1.31	1.50	1.79		24.0
19-1	19-9	20-4	21-0	21-7	22-2	22-9	23-4	23-11	24-11	26-6		12.0
0.94	1.05	1.15	1.26	1.38	1.49	1.61	1.73	1.86	2.12	2.53		
17-10	18-5	19-1	19-8	20-2	20-9	21-4	21-10	22-4	23-4	24-9		13.7
0.88	0.98	1.08	1.18	1.29	1.40	1.51	1.62	1.74	1.98	2.36		
16-6	17-1	17-8	18-2	18-9	19-3	19-9	20-2	20-8	21-7	22-11		24.2
0.82	0.91	1.00	1.09	1.19	1.29	1.40	1.50	1.61	1.83	2.19		16.0
15-1	15-7	16-1	16-7	17-1	17-7	18-0	18-5	18-11	19-9	20-11		22.1
0.75	0.83	0.91	1.00	1.08	1.18	1.27	1.37	1.47	1.67	2.00		19.2
13-6	13-11	14-5	14-10	15-3	15-8	16-1	16-6	16-11	17-8	18-9		24.0
0.67	0.74	0.82	0.89	0.97	1.06	1.14	1.23	1.31	1.50	1.79		

Note: The required modulus of elasticity, "E" in 1,000,000 pounds per square inch is shown below each span.

TABLE R-14
MEDIUM OR HIGH SLOPE RAFTERS
 No Ceiling Load
 Slope over 3 in 12
 Live Load - 30 lb. per sq. ft.
 (Light roof covering)
 Use in Zone 2

DESIGN CRITERIA:
 Strongth - 7 lbs. per sq. ft. dead load plus
 30 lbs. per sq. ft. live load determines
 required fiber stress.
 Deflection - For 30 lbs. per sq. ft. live load.
 Limited to span in inches divided by 180.

RAFTER SIZE SPACING (IN.)	Extreme Fiber Stress in Bending, "F _b " (psi).											
	200	300	400	500	600	700	800	900	1000	1100	1200	1300
12.0	3.4	4.1	4.8	5.3	5.8	6.3	6.8	7.1	7.5	7.9	8.2	8.6
	0.07	0.13	0.20	0.27	0.36	0.45	0.55	0.66	0.77	0.89	1.02	1.15
	3.1	3.10	4.5	4.11	5.5	5.10	6.3	6.7	8.11	7.3	7.7	7.11
13.7	0.06	0.12	0.18	0.26	0.34	0.42	0.52	0.62	0.72	0.84	0.95	1.07
2x4	2.11	3.6	4.1	4.7	5.0	5.5	5.9	6.1	6.5	6.9	7.1	7.4
	0.06	0.11	0.17	0.24	0.31	0.39	0.48	0.57	0.67	0.77	0.88	0.99
	2.8	3.3	3.9	4.2	4.7	4.11	5.3	5.7	6.2	6.2	6.5	6.8
19.2	0.05	0.10	0.15	0.22	0.28	0.36	0.44	0.52	0.61	0.71	0.80	0.91
24.0	2.4	2.11	3.4	3.9	4.1	4.5	4.8	5.0	5.3	5.6	5.9	6.0
	0.05	0.09	0.14	0.19	0.25	0.32	0.39	0.47	0.55	0.63	0.72	0.81
	5.3	6.5	7.5	8.3	9.1	9.9	10.5	11.1	11.8	12.3	12.9	13.4
12.0	0.07	0.13	0.20	0.27	0.36	0.45	0.55	0.66	0.77	0.89	1.02	1.15
13.7	4.11	6.0	6.11	7.9	8.5	9.2	9.9	10.4	10.11	11.5	12.0	12.5
	0.06	0.12	0.18	0.26	0.34	0.42	0.52	0.62	0.72	0.84	0.95	1.07
	4.6	5.6	6.5	7.2	7.10	8.5	9.1	9.7	10.1	10.7	11.1	11.6
16.0	0.06	0.11	0.17	0.24	0.31	0.39	0.48	0.57	0.67	0.77	0.88	0.99
19.2	4.2	5.1	5.10	5.6	7.2	7.9	8.3	8.9	9.2	9.2	10.1	10.6
	0.05	0.10	0.15	0.22	0.28	0.36	0.44	0.52	0.61	0.71	0.80	0.91
	3.8	4.6	5.3	5.10	6.5	7.5	8.11	8.8	9.1	9.5	9.5	9.5
24.0	0.05	0.09	0.14	0.19	0.25	0.32	0.39	0.47	0.55	0.63	0.72	0.81

	12.0	6-11	8-5	9-9	10-11	11-11	12-10	13-9	14-7	15-5	16-2	16-10	17-7
		0.07	0.13	0.20	0.27	0.36	0.45	0.55	0.66	0.77	0.89	1.02	1.15
	13.7	6-5	7-11	8-1	10-2	11-2	12-1	12-10	13-8	14-5	15-1	15-9	16-5
		0.06	0.12	0.18	0.26	0.34	0.42	0.52	0.62	0.72	0.84	0.95	1.07
2x8	16.0	6-0	7-4	8-5	9-5	10-4	11-2	11-11	12-8	13-4	14-0	14-7	15-2
		0.06	0.11	0.17	0.24	0.31	0.39	0.48	0.57	0.67	0.77	0.88	0.99
	18.2	5-5	6-8	7-8	8-7	9-5	10-2	10-11	11-5	12-2	12-9	13-4	13-10
		0.05	0.10	0.15	0.22	0.28	0.36	0.44	0.52	0.61	0.71	0.80	0.91
	24.0	4-10	5-0	6-11	7-8	8-5	9-1	9-9	10-4	10-11	11-5	11-11	12-5
		0.05	0.09	0.14	0.19	0.25	0.32	0.39	0.47	0.55	0.63	0.72	0.81
	12.0	8-9	10-9	12-5	13-11	15-2	16-5	17-7	18-7	19-8	20-7	21-6	22-5
		0.07	0.13	0.20	0.27	0.36	0.45	0.55	0.66	0.77	0.89	1.02	1.15
	13.7	8-3	10-1	11-7	13-0	14-3	15-4	16-5	17-5	18-4	19-3	20-1	20-11
		0.06	0.12	0.18	0.26	0.34	0.42	0.52	0.62	0.72	0.84	0.95	1.07
2x10	16.0	7-7	9-4	10-9	12-0	13-2	14-3	15-2	16-2	17-0	17-10	18-7	19-5
		0.07	0.12	0.19	0.26	0.34	0.43	0.53	0.63	0.74	0.85	0.97	1.09
	18.2	6-11	8-6	9-10	11-0	12-0	13-0	13-11	14-9	15-6	16-3	17-0	17-8
		0.05	0.10	0.15	0.22	0.28	0.36	0.44	0.52	0.61	0.71	0.80	0.91
	24.0	6-2	7-7	8-9	9-10	10-9	11-7	12-5	13-2	13-11	14-7	15-2	15-10
		0.05	0.09	0.14	0.19	0.25	0.32	0.39	0.47	0.55	0.63	0.72	0.81

Note: The required modulus of elasticity, "E", in 1,000,000 pounds per square inch is shown below each span.

TABLE R-14 (cont.)

RAFTERS: Spans are measured along the horizontal projection and loads are considered as applied on the horizontal projection.

Extreme Fiber Stress in Bending, "F _b " (psi).											RAFTER SPACING SIZE (IN)	
1400	1500	1600	1700	1800	1900	2000	2100	2200	2400	2700	(IN)	(IN)
8-9 1.28	9-1 1.42	9-5 1.57	9-8 1.72	10-0 1.87	10-3 2.03	10-6 2.19	10-9 2.36	11-0 2.53			12.0	2x4
8-3 1.20	8-6 1.33	8-9 1.47	9-1 1.61	9-4 1.75	9-7 1.90	9-10 2.05	10-1 2.20	10-4 2.36			13.7	
7-7 1.11	7-11 1.23	8-2 1.36	8-5 1.49	8-8 1.62	8-10 1.76	9-1 1.90	9-4 2.04	9-7 2.19	10-0 2.49		16.0	
6-11 1.01	7-2 1.12	7-5 1.24	7-8 1.36	7-11 1.48	8-1 1.60	8-4 1.73	8-6 1.86	8-9 2.00	9-1 2.28		19.2	
6-3 0.91	6-5 1.01	6-8 1.11	6-10 1.21	7-1 1.32	7-3 1.43	7-5 1.55	7-7 1.67	7-9 1.79	8-2 2.04	8-8 2.43	24.0	
13-10 1.28	14-4 1.42	14-9 1.57	15-3 1.72	15-8 1.87	16-1 2.03	16-6 2.19	16-11 2.36	17-4 2.53			12.0	
12-11 1.20	13-4 1.33	13-10 1.47	14-3 1.61	14-8 1.75	15-1 1.90	15-5 2.05	15-10 2.20	16-2 2.36			13.7	
12-0 1.11	12-5 1.23	12-9 1.36	13-2 1.49	13-7 1.62	13-11 1.76	14-4 1.90	14-8 2.04	15-0 2.19	15-8 2.49		16.0	
10-11 1.01	11-4 1.12	11-8 1.24	12-0 1.36	12-5 1.48	12-9 1.60	13-1 1.73	13-4 1.86	13-8 2.00	14-4 2.28		19.2	
9-9 0.91	10-1 1.01	10-5 1.11	10-9 1.21	11-1 1.32	11-5 1.43	11-8 1.55	12-0 1.67	12-3 1.79	12-9 2.04	13-7 2.43	24.0	

18-2 1.28	18-10 1.42	19-6 1.57	20-1 1.72	20-8 1.87	21-3 2.03	21-9 2.19	22-4 2.36	22-10 2.53			12.0	2x8
17-0 1.20	17-8 1.33	18-2 1.47	18-9 1.61	19-4 1.75	19-10 1.90	20-4 2.05	20-10 2.20	21-4 2.36			13.7	
15-9 1.11	16-4 1.23	16-10 1.36	17-4 1.49	17-11 1.62	18-4 1.76	18-10 1.90	19-4 2.04	19-9 2.19	20-8 2.49		16.0	
14-5 1.01	14-11 1.12	15-5 1.24	15-10 1.38	16-4 1.48	16-9 1.60	17-2 1.73	17-8 1.86	18-1 2.00	18-10 2.28		19.2	
12-10 0.91	13-4 1.01	13-9 1.11	14-2 1.21	14-7 1.32	15-0 1.43	15-5 1.55	15-9 1.67	16-2 1.79	16-10 2.04	17-11 2.43	24.0	2x10
23-3 1.28	24-1 1.42	24-10 1.57	25-7 1.72	26-4 1.87	27-1 2.03	27-9 2.19	28-5 2.36	29-1 2.53			12.0	
21-9 1.20	22-6 1.33	23-3 1.47	23-11 1.61	24-8 1.75	25-4 1.90	26-0 2.05	26-7 2.20	27-3 2.36			13.7	
20-1 1.22	20-10 1.35	21-6 1.49	22-2 1.63	22-10 1.78	23-5 1.93	24-1 2.08	24-8 2.24	25-3 2.40			16.0	
18-4 1.01	19-0 1.12	19-8 1.24	20-3 1.36	20-10 1.48	21-5 1.60	21-11 1.73	22-6 1.86	23-0 2.00	24-1 2.26		19.2	2x10
16-5 0.91	17-0 1.01	17-7 1.11	18-1 1.21	18-7 1.32	19-2 1.43	19-8 1.55	20-1 1.67	20-7 1.79	21-6 2.04	22-10 2.43	24.0	

Note: The required modulus of elasticity, "E", in 1,000,000 pounds per square inch is shown below each span.

TABLE R-15
MEDIUM OR HIGH SLOPE RAFTERS
 No Ceiling Load
 Slope over 3 in 12
 Live Load - 40 lb. per sq. ft.
 (Light roof covering)
 Use in Zone 1

DESIGN CRITERIA:
 Strength - 7 lbs. per sq. ft. dead load plus
 40 lbs. per sq. ft. live load determines
 required fiber stress.
 Deflection - For 40 lbs. per sq. ft. live load,
 Limited to span in inches divided by 180.

RAFTER SIZE SPACING (IN)	Extreme Fiber Stress in Bending, "F _b " (psi).											
	200	300	400	500	600	700	800	900	1000	1100	1200	1300
12.0	2-11	3-7	4-2	4-8	5-1	5-6	5-11	6-3	6-7	6-11	7-3	7-6
	0-06	0-12	0-18	0-25	0-34	0-42	0-52	0-62	0-72	0-83	0-95	1-07
	2-9	3-5	3-11	4-4	4-9	5-2	5-6	5-10	6-2	6-6	6-9	7-0
13.7	0-06	0-11	0-17	0-24	0-31	0-40	0-48	0-58	0-67	0-78	0-89	1-00
	2-7	3-2	3-7	4-0	4-5	4-9	5-1	5-5	5-8	6-0	6-3	6-6
	0-06	0-10	0-16	0-22	0-29	0-37	0-45	0-53	0-62	0-72	0-82	0-93
19.2	2-4	2-10	3-4	3-8	4-0	4-4	4-8	4-11	5-3	5-6	5-8	5-11
	0-05	0-09	0-14	0-20	0-26	0-33	0-41	0-49	0-57	0-66	0-75	0-85
	2-1	2-7	2-11	3-4	3-7	3-11	4-2	4-5	4-8	4-11	5-1	5-4
24.0	0-05	0-08	0-13	0-18	0-24	0-30	0-36	0-44	0-51	0-59	0-67	0-76
	4-8	5-8	6-7	7-4	8-0	8-8	9-3	9-10	10-4	10-10	11-4	11-10
	0-06	0-12	0-18	0-25	0-34	0-42	0-52	0-62	0-72	0-83	0-95	1-07
13.7	4-4	5-4	6-2	6-10	7-6	8-1	8-8	9-2	9-8	10-2	10-7	11-1
	0-06	0-11	0-17	0-24	0-31	0-40	0-48	0-58	0-67	0-78	0-89	1-00
	4-0	4-11	5-8	6-4	6-11	7-6	8-0	8-6	9-0	9-5	9-10	10-3
16.0	0-06	0-10	0-16	0-22	0-29	0-37	0-45	0-53	0-62	0-72	0-82	0-93
	3-8	4-6	5-2	5-9	6-4	6-10	7-4	7-9	8-2	8-7	9-0	9-4
	0-05	0-09	0-14	0-20	0-26	0-33	0-41	0-49	0-57	0-66	0-75	0-85
19.2	3-3	4-0	4-8	5-2	5-8	6-2	6-7	6-11	7-4	7-8	8-0	8-4
	0-05	0-08	0-13	0-18	0-24	0-30	0-36	0-44	0-51	0-59	0-67	0-76
	4-0	4-11	5-8	6-4	6-11	7-6	8-0	8-6	9-0	9-5	9-10	10-3
24.0	0-05	0-08	0-13	0-18	0-24	0-30	0-36	0-44	0-51	0-59	0-67	0-76
	4-8	5-8	6-7	7-4	8-0	8-8	9-3	9-10	10-4	10-10	11-4	11-10
	0-06	0-12	0-18	0-25	0-34	0-42	0-52	0-62	0-72	0-83	0-95	1-07

	12.0	5.9	7.0	8.1	9.8	10.7	11.5	12.3	12.11	13.8	14.4	14.11	15.7
		0.06	0.12	0.18	0.25	0.34	0.42	0.52	0.62	0.72	0.83	0.95	1.07
	13.7	0.06	0.11	0.17	0.24	0.31	0.40	0.48	0.58	0.67	0.78	0.89	1.00
2x8	16.0	5.3	6.6	7.6	8.4	9.2	9.11	10.7	11.3	11.10	12.5	12.11	13.6
		0.06	0.10	0.16	0.22	0.29	0.37	0.45	0.53	0.62	0.72	0.82	0.93
	19.2	4.10	5.11	6.10	7.8	8.4	9.0	9.8	10.3	10.10	11.4	11.10	12.4
		0.05	0.09	0.14	0.20	0.26	0.33	0.41	0.49	0.57	0.66	0.75	0.85
	24.0	4.4	5.3	6.1	8.10	7.6	8.1	8.8	9.2	9.8	10.2	10.7	11.0
		0.05	0.08	0.13	0.18	0.24	0.30	0.36	0.44	0.51	0.59	0.67	0.76
	12.0	7.3	9.6	11.0	12.4	13.6	14.7	15.7	16.6	17.5	18.3	19.1	19.10
		0.06	0.12	0.18	0.25	0.34	0.42	0.52	0.62	0.72	0.83	0.95	1.07
	13.7	7.3	8.11	10.4	11.6	12.7	13.8	14.7	15.5	16.4	17.1	17.10	18.7
		0.06	0.11	0.17	0.24	0.31	0.40	0.48	0.58	0.67	0.78	0.89	1.00
2x10	16.0	6.9	8.3	9.6	10.8	11.8	12.7	13.6	14.4	15.1	15.10	16.6	17.2
		0.06	0.10	0.16	0.22	0.29	0.37	0.45	0.53	0.62	0.72	0.82	0.93
	19.2	6.2	7.7	8.9	9.9	10.8	11.6	12.4	13.1	13.9	14.5	15.1	15.8
		0.05	0.09	0.14	0.20	0.26	0.33	0.41	0.49	0.57	0.66	0.75	0.85
	24.0	5.6	6.9	7.9	8.9	9.6	10.4	11.0	11.8	12.4	12.11	13.6	14.1
		0.05	0.08	0.13	0.18	0.24	0.30	0.36	0.44	0.51	0.59	0.67	0.76

Note: The required modulus of elasticity, "E", in 1,000,000 pounds per square inch is shown below each span.

TABLE R-15 (cont.)

RAFTERS: Spans are measured along the horizontal projection and loads are considered as applied on the horizontal projection.

Extreme Fiber Stress in Bending, "F _b " (psi.)													RAFTER SPACING SIZE (IN)	
	1500	1600	1700	1800	1900	2000	2100	2200	2400	2700				
1400														
7-10	8-1	8-4	8-7	8-10	9-1	9-4	9-7	9-9				12.0		
1-19	1-32	1-46	1-60	1-74	1-89	2-04	2-19	2-35						
7-4	7-7	7-10	8-0	8-3	8-6	8-9	8-11	9-2	9-7					
1-12	1-24	1-37	1-50	1-63	1-77	1-91	2-05	2-20	2-51			13.7		
6-9	7-0	7-3	7-5	7-8	7-10	8-1	8-3	8-6	8-10					
1-03	1-15	1-26	1-38	1-51	1-64	1-77	1-90	2-04	2-32			16.0		
6-2	6-5	6-7	6-10	7-0	7-2	7-4	7-7	7-9	8-1	8-7		2x4		
0-84	1-05	1-15	1-26	1-38	1-49	1-61	1-74	1-86	2-12	2-53		19.2		
5-6	5-8	5-11	6-1	6-3	6-5	6-7	6-9	6-11	7-3	7-8				
0-84	0-94	1-03	1-13	1-23	1-34	1-44	1-55	1-66	1-90	2-26		24.0		
12-3	12-8	13-1	13-6	13-11	14-3	14-8	15-0	15-4						
1-19	1-32	1-46	1-60	1-74	1-89	2-04	2-19	2-35						
11-6	11-10	12-3	12-8	13-0	13-4	13-8	14-0	14-4	15-0					
1-12	1-24	1-37	1-50	1-63	1-77	1-91	2-05	2-20	2-51			13.7		
10-7	11-0	11-4	11-8	12-0	12-4	12-8	13-0	13-4	13-11					
1-03	1-15	1-26	1-38	1-51	1-64	1-77	1-90	2-04	2-32			16.0		
9-8	10-0	10-4	10-8	11-0	11-3	11-7	11-10	12-2	12-8	13-5		2x6		
0-94	1-05	1-15	1-26	1-38	1-49	1-61	1-74	1-86	2-12	2-53		19.2		
8-8	9-0	9-3	9-7	9-10	10-1	10-4	10-7	10-10	11-4	12-0				
0-84	0-94	1-03	1-13	1-23	1-34	1-44	1-55	1-66	1-90	2-26		24.0		

16.2	16.9	17.3	17.10	18.4	19.10	19.4	19.9	20.3				12.0
1.19	1.32	1.46	1.60	1.74	1.89	2.04	2.19	2.35				
15.1	15.8	16.2	16.8	17.2	17.7	18.1	18.6	18.11	19.9			13.7
1.12	1.24	1.37	1.50	1.63	1.77	1.91	2.05	2.20	2.51			
14.0	14.6	14.11	15.5	15.10	16.4	16.9	17.2	17.6	18.4			16.0
1.03	1.15	1.26	1.38	1.51	1.64	1.77	1.90	2.04	2.32			2x8
12.9	13.3	13.8	14.1	14.6	14.11	15.3	15.8	16.0	16.9	17.9		
0.94	1.05	1.15	1.26	1.38	1.49	1.61	1.74	1.86	2.12	2.53		19.2
11.5	11.10	12.3	12.7	12.11	13.4	13.8	14.0	14.4	14.11	15.10		
0.84	0.94	1.03	1.13	1.23	1.34	1.44	1.55	1.66	1.90	2.26		24.0
20.7	21.4	22.0	22.9	23.4	24.0	24.8	25.3	25.10				
1.19	1.32	1.48	1.60	1.74	1.89	2.04	2.19	2.35				12.0
19.3	19.11	20.7	21.3	21.10	22.6	23.1	23.7	24.2	25.3			
1.12	1.24	1.37	1.50	1.63	1.77	1.91	2.05	2.20	2.51			13.7
17.10	18.6	19.1	19.8	20.3	20.10	21.4	21.10	22.4	23.4			
1.03	1.15	1.26	1.38	1.51	1.64	1.77	1.90	2.04	2.32			16.0
16.4	16.10	17.5	17.11	18.6	19.0	19.6	19.11	20.5	21.4	22.8		
0.94	1.05	1.15	1.26	1.38	1.49	1.61	1.74	1.86	2.12	2.53		19.2
14.7	15.1	15.7	16.1	16.6	17.0	17.5	17.10	18.3	19.1	20.3		
0.84	0.94	1.03	1.13	1.23	1.34	1.44	1.55	1.66	1.90	2.26		24.0

Note: The required modulus of elasticity, "E", in 1,000,000 pounds per square inch is shown below each span.

TABLE TSM-1
TWO-SPAN FLOOR JOISTS
40 Lbs. Per Sq. Ft. Live Load
(All rooms except those used for sleeping areas and attic floors)

DESIGN CRITERIA:
Deflection - For 40 lbs. per sq. ft. live load on one span and 20 lbs. per sq. ft. on other. Limited to span in inches divided by 360.
Strength - Live load of 40 lbs. per sq. ft. plus dead load of 10 lbs. per sq. ft. on both spans determines the required fiber stress value.

JOIST SIZE SPACING (IN)	Modulus of Elasticity, "E", in 1,000,000 psi																
	0.8	0.9	1.0	1.1	1.2	1.3	1.4	1.5	1.6	1.7	1.8	1.9	2.0	2.2	2.4	2.6	
12.0	10.3	10.8	11.1	11.5	11.9	12.3	12.5	12.8	13.0	13.3	13.6	13.9	14.0	14.2	14.5	14.8	
	1060	1150	1230	1310	1390	1460	1540	1610	1680	1750	1820	1880	1950	2010	2060	2140	
13.7	9.10	10.3	10.7	10.11	11.3	11.7	11.10	12.2	12.5	12.8	12.11	13.1	13.4	13.7	13.9	14.0	
	1110	1200	1290	1370	1450	1530	1610	1680	1760	1830	1900	1970	2040	2100	2170	2240	
16.0	8.4	9.9	10.1	10.5	10.8	11.0	11.3	11.6	11.9	12.0	12.3	12.6	12.8	12.11	13.2	13.4	
	1170	1260	1350	1440	1530	1610	1690	1770	1850	1920	2000	2070	2140	2210	2280	2350	
19.2	8.9	9.2	9.6	9.9	10.1	10.4	10.7	10.10	11.1	11.4	11.6	11.9	11.11	12.2	12.4	12.6	
	1240	1340	1440	1530	1620	1710	1800	1890	1960	2040	2120	2200	2280	2350	2430	2500	
24.0	8.2	8.6	8.9	9.1	9.4	9.7	9.10	10.1	10.3	10.6	10.8	10.11	11.1	11.3	11.5	11.7	
	1330	1440	1550	1650	1750	1840	1940	2030	2120	2200	2280	2370	2450	2530	2610	2690	
12.0	13.7	14.1	14.7	15.1	15.6	15.11	16.4	16.9	17.1	17.5	17.9	18.1	18.5	18.9	19.0	19.4	
	1060	1150	1230	1310	1390	1460	1540	1610	1680	1750	1820	1880	1950	2010	2080	2140	
13.7	13.0	13.6	14.0	14.5	14.10	15.3	15.8	16.0	16.4	16.8	17.0	17.4	17.7	17.11	18.2	18.6	
	1110	1200	1290	1370	1450	1530	1610	1680	1760	1830	1900	1970	2040	2110	2180	2240	
16.0	12.4	12.10	13.3	13.8	14.1	14.6	14.10	15.2	15.6	15.10	16.2	16.5	16.9	17.0	17.3	17.6	
	1170	1260	1350	1440	1530	1610	1690	1770	1850	1930	2000	2070	2150	2220	2290	2360	
19.2	11.7	12.1	12.6	12.11	13.3	13.8	14.0	14.4	14.7	14.11	15.2	15.6	15.9	16.0	16.3	16.6	
	1240	1340	1440	1530	1620	1710	1800	1880	1970	2050	2130	2200	2280	2360	2430	2500	
24.0	10.9	11.2	11.7	12.0	12.4	12.8	13.0	13.3	13.7	13.10	14.1	14.4	14.7	14.10	15.1	15.4	
	1340	1440	1550	1650	1750	1840	1940	2030	2120	2200	2280	2370	2460	2540	2620	2700	

2x10	12.0	17-4	18-0	18-8	19-3	19-10	20-4	20-10	21-4	21-10	22-3	22-8	23-1	23-6	23-11	24-3	24-8
		1060	1150	1230	1310	1390	1460	1540	1610	1680	1750	1820	1880	1950	2010	2080	2140
	13.7	16-7	17-3	17-10	18-5	19-0	19-6	20-0	20-5	20-10	21-4	21-9	22-1	22-6	22-10	23-3	23-7
		1110	1200	1290	1370	1450	1530	1610	1680	1760	1830	1900	1970	2040	2110	2170	2240
2x10	16.0	15-9	16-4	16-11	17-6	18-0	18-6	19-0	19-5	19-10	20-3	20-7	21-0	21-4	21-9	22-1	22-5
		1170	1260	1350	1440	1530	1610	1690	1770	1850	1930	2000	2070	2150	2220	2290	2360
	19.2	14-10	15-5	15-11	16-6	16-11	17-5	17-10	18-3	18-8	19-0	19-5	19-9	20-1	20-5	20-9	21-1
		1240	1340	1440	1530	1620	1710	1800	1880	1970	2050	2130	2200	2280	2360	2430	2500
2x10	24.0	13-9	14-3	14-9	15-3	15-9	16-2	16-7	16-11	17-4	17-8	18-0	18-4	18-8	19-0	19-3	19-7
		1340	1440	1550	1650	1750	1840	1940	2030	2120	2200	2280	2370	2460	2540	2620	2700
	12.0	21-1	21-11	22-8	23-5	24-1	24-9	25-5	26-0	26-7	27-1	27-7	28-1	28-7	29-1	29-6	30-0
		1060	1150	1230	1310	1390	1460	1540	1610	1680	1750	1820	1880	1950	2010	2080	2140
2x12	13.7	11-10	12-00	12-90	13-70	14-50	15-30	16-10	16-90	17-80	18-60	19-40	20-20	21-00	21-80	22-60	23-40
		1110	1200	1290	1370	1450	1530	1610	1690	1780	1860	1940	2020	2100	2180	2260	2340
	16.0	19-2	19-11	20-7	21-3	21-11	22-6	23-1	23-7	24-1	24-7	25-1	25-7	26-0	26-5	26-10	27-3
		1170	1260	1350	1440	1530	1610	1690	1770	1850	1930	2000	2070	2150	2220	2290	2360
2x12	19.2	18-0	18-9	19-5	20-0	20-7	21-2	21-8	22-3	22-8	23-2	23-7	24-0	24-5	24-10	25-3	25-7
		1240	1340	1440	1530	1620	1710	1800	1880	1970	2050	2130	2200	2280	2360	2430	2500
	24.0	16-9	17-5	18-0	18-7	19-2	19-8	20-3	20-8	21-1	21-6	21-11	22-4	22-8	23-1	23-5	23-9
		1340	1440	1550	1650	1750	1840	1940	2030	2120	2200	2280	2370	2460	2540	2620	2700

Note: The required extreme fiber stress in bending, "F_b", in pounds per square inch is shown below each span.

TABLE TSJ-2
TWO-SPAN FLOOR JOISTS
30 Lbs. Per Sq. Ft. Live Load
(All rooms used for sleeping and attic floors)

DESIGN CRITERIA:
Deflection - F or 30 lbs. per sq. ft. live load on one span and 15 lbs. per sq. ft. on other limited to span in inches divided by 360.
Strength - Live load of 30 lbs. per sq. ft. plus dead load of 10 lbs. per sq. ft. on both spans determines the required fiber stress value.

JOIST SIZE SPACING (IN)	Modulus of Elasticity, "E", in 1,000,000 psi															
	0.8	0.9	1.0	1.1	1.2	1.3	1.4	1.5	1.6	1.7	1.8	1.9	2.0	2.2	2.4	2.6
2x6	11-4	11-9	12-2	12-7	13-0	13-4	13-8	14-0	14-3	14-7	14-10	15-1	15-5	15-8	15-10	16-1
	10-30	11-10	11-90	12-70	13-40	14-20	14-90	15-60	16-30	17-00	17-60	18-30	18-90	19-50	20-10	20-70
	10-10	11-3	11-8	12-0	12-5	12-9	13-1	13-4	13-8	13-11	14-2	14-5	14-8	14-11	15-2	15-5
	10-70	11-60	12-50	13-30	14-10	14-80	15-60	16-30	17-00	17-70	18-40	19-10	19-70	20-40	21-00	21-70
	10-3	10-8	11-1	11-5	11-9	12-1	12-5	12-8	13-0	13-3	13-6	13-9	14-0	14-2	14-5	14-8
	11-30	12-20	13-10	14-00	14-90	15-60	16-40	17-20	17-90	18-70	19-40	20-10	20-80	21-50	22-10	22-80
	9-8	10-7	10-5	10-8	11-1	11-5	11-8	11-11	12-2	12-5	12-8	13-1	13-2	13-4	13-7	13-9
	12-00	13-00	13-90	14-80	15-70	16-60	17-40	18-20	19-00	19-80	20-60	21-30	22-10	22-80	23-50	24-20
	9-0	9-4	9-8	10-0	10-3	10-7	10-10	11-1	11-4	11-7	11-9	12-0	12-2	12-5	12-7	12-9
	12-90	14-00	15-00	16-00	16-90	17-90	18-80	19-60	20-50	21-30	22-20	23-00	23-80	24-60	25-30	26-10
2x8	14-11	15-6	16-1	16-7	17-1	17-7	18-0	18-5	18-70	19-2	19-7	19-11	20-3	20-7	20-11	21-3
	10-30	11-10	11-90	12-70	13-50	14-20	14-90	15-60	16-30	17-00	17-60	18-30	18-90	19-50	20-10	20-70
	14-3	14-10	15-5	15-11	16-4	16-10	17-3	17-7	18-0	18-4	18-9	19-1	19-5	19-9	20-4	20-4
	10-80	11-60	12-50	13-30	14-10	14-80	15-60	16-30	17-00	17-70	18-40	19-10	19-80	20-40	21-00	21-70
	13-7	14-1	14-7	15-1	15-6	15-11	16-4	16-9	17-1	17-5	17-9	18-1	18-5	18-9	19-0	19-4
	11-30	12-20	13-10	14-00	14-90	15-60	16-40	17-20	17-90	18-70	19-40	20-10	20-80	21-50	22-20	22-80
	21-3	13-3	13-9	14-2	14-7	15-0	15-5	15-9	16-1	16-5	16-9	17-0	17-4	17-7	17-11	18-2
	12-00	13-00	13-90	14-80	15-70	16-60	17-40	18-20	19-10	19-80	20-60	21-40	22-10	22-80	23-50	24-30
	11-10	12-4	12-9	13-2	13-7	13-11	14-3	14-7	14-11	15-3	15-6	15-10	16-1	16-4	16-7	16-10
	12-90	14-00	15-00	16-00	16-90	17-90	18-80	19-70	20-50	21-30	22-20	23-00	23-80	24-60	25-40	26-10

12.0	18-1	19-10	20-6	21-2	21-10	22-5	23-0	23-6	24-0	24-6	25-0	25-5	25-11	26-4	26-9	27-1
	1030	1110	1180	1270	1350	1420	1490	1560	1630	1700	1760	1830	1890	1950	2010	2070
	18-3	19-0	19-8	20-3	20-11	21-5	22-0	22-6	23-0	23-5	23-11	24-4	24-9	25-2	25-7	25-11
	1080	1160	1250	1330	1410	1480	1560	1630	1700	1770	1840	1910	1980	2040	2110	2170
13.7	17-4	18-0	18-8	19-3	19-10	20-4	20-11	21-4	21-10	22-3	22-8	23-1	23-6	23-11	24-3	24-8
	1120	1220	1310	1400	1480	1560	1640	1720	1790	1870	1940	2010	2080	2150	2220	2280
	16-4	16-11	17-7	18-1	18-8	19-2	19-8	20-1	20-6	20-11	21-4	21-9	22-1	22-6	22-10	23-2
	1200	1300	1390	1490	1570	1660	1740	1830	1910	1980	2060	2140	2210	2280	2350	2430
24.0	15-1	15-9	16-4	16-10	17-4	17-9	18-3	18-8	19-1	19-5	19-10	20-2	20-6	20-11	21-2	21-6
	1290	1400	1500	1600	1690	1790	1880	1970	2050	2140	2220	2300	2380	2460	2540	2610
	23-2	24-1	25-0	25-10	26-7	27-3	27-11	28-7	29-3	29-10	30-5	30-11	31-5	32-0	32-6	33-0
	1030	1110	1190	1270	1350	1420	1490	1560	1630	1700	1760	1830	1890	1950	2010	2070
13.7	22-2	23-1	23-11	24-8	25-5	26-1	26-9	27-4	27-11	28-6	29-1	29-7	30-1	30-7	31-1	31-7
	1080	1160	1250	1330	1410	1480	1560	1630	1700	1770	1840	1910	1980	2040	2110	2170
	21-1	21-11	22-8	23-5	24-1	24-9	25-5	26-0	26-7	27-1	27-7	28-1	28-7	29-1	29-6	30-0
	1130	1220	1310	1400	1480	1560	1640	1720	1790	1870	1940	2010	2080	2150	2220	2280
16.0	18-10	20-7	21-4	22-1	22-8	23-4	23-11	24-5	25-0	25-6	26-0	26-6	26-11	27-4	27-9	28-2
	1200	1300	1390	1490	1570	1660	1740	1830	1910	1980	2060	2140	2210	2280	2350	2430
	18-5	19-2	19-10	20-6	21-1	21-8	22-2	22-8	23-2	23-8	24-2	24-7	25-0	25-5	25-10	26-2
	1290	1400	1500	1600	1690	1790	1880	1970	2050	2140	2220	2300	2380	2460	2540	2610

Note: The required extreme fiber stress in bending, "F_b", in pounds per square inch is shown below each span.

DESIGN VALUES FOR JOISTS AND RAFTERS - VISUAL GRADING

These "F_b" values are for use where repetitive members are spaced not more than 24 inches. For wider spacing, the "F_b" values should be reduced 13 percent.

Values for surfaced dry or surfaced green lumber apply at 19 percent maximum moisture content in use.

Species and Grade	Size	Design Value in Bending "F _b "		Modulus of Elasticity "E"	Grading Rules Agency
		Joists	Rafters		
BALSAM FIR (Surfaced dry or surfaced green)					
Select Structural	2x4	2000	2100	1,500,000	Northeastern Lumber Manufacturers Association
No. 1		1700	1790	1,500,000	
No. 2		1400	1470	1,300,000	
No. 3		775	810	1,200,000	
Appearance		1700	1790	1,500,000	
Stud		775	810	1,200,000	Northern Hardwood & Pine Manufacturers Association
Construction	2x4	1000	1050	1,200,000	
Standard		575	600	1,200,000	
Utility		275	290	1,200,000	
Select Structural	2x5 and wider	1700	1790	1,500,000	(See notes 1 and 3).
No. 1 & Appearance		1450	1520	1,500,000	
No. 2		1200	1260	1,300,000	
No. 3		700	740	1,200,000	
Stud		700	740	1,200,000	

DOUGLAS FIR - LARCH (Surfaced dry or surfaced green)					
Dense Select Structural		2800	2940	1,900,000	
Select Structural		2400	2520	1,800,000	
Dense No. 1		2400	2520	1,900,000	
No. 1 & Appearance	2x4	2050	2150	1,800,000	
Dense No. 2		1950	2050	1,700,000	
No. 2		1650	1730	1,700,000	Western Wood
No. 3		925	970	1,500,000	Products
Stud		925	970	1,500,000	Association
					(See notes 1
Construction		1200	1260	1,500,000	and 3)
Standard	2x4	675	710	1,500,000	
Utility		325	340	1,500,000	
					West Coast
Dense Select Structural		2400	2520	1,900,000	Lumber
Select Structural		2050	2150	1,800,000	Inspection
Dense No. 1	2x5	2050	2150	1,900,000	Bureau
No. 1 & Appearance	and	1750	1840	1,800,000	
	wider				
Dense No. 2		1700	1790	1,700,000	
No. 2		1450	1520	1,700,000	
No. 3		850	890	1,500,000	
Stud		850	890	1,500,000	

DESIGN VALUES FOR JOISTS AND RAFTERS - VISUAL GRADING (Cont)

These "F_b" values are for use where repetitive members are spaced not more than 24 inches. For wider spacing, the "F_b" values should be reduced 13 percent.

Values for surfaced dry or surfaced green lumber apply at 19 percent maximum moisture content in use.

Species and Grade	Size	Design Value in Bending "F _b "		Modulus of Elasticity "E"	Grading Rules Agency
		Joists	Rafters		
EASTERN HEMLOCK (Surfaced dry or surfaced green)					
Select Structural	2x4	2050	2150	1,200,000	Northern Hardwood & Pine Manufacturers Association
No. 1		1750	1840	1,200,000	
No. 2		1450	1520	1,100,000	
No. 3		800	840	1,000,000	
Appearance		1750	1840	1,200,000	
Stud		800	840	1,000,000	Northeastern Lumber
Construction	2x4	1050	1100	1,000,000	Manufacturers Association
Standard		575	600	1,000,000	
Utility		275	290	1,000,000	
Select Structural	2x5 and wider	1750	1840	1,200,000	(See notes 1 and 3)
No. 1 & Appearance		1500	1580	1,200,000	
No. 2		1250	1310	1,100,000	
No. 3		700	740	1,000,000	
Stud		700	740	1,000,000	

EASTERN SPRUCE (Surfaced dry or surfaced green)					
Select Structural		1600	1680	1,500,000	Northeastern Lumber Manufacturers Association
No. 1		1350	1420	1,500,000	
No. 2	2x4	1100	1160	1,400,000	
No. 3		625	660	1,200,000	
Appearance		1350	1420	1,500,000	
Stud		625	660	1,200,000	Northern Hardwood
Construction		800	840	1,200,000	& Pine Manufacturers Association
Standard	2x4	450	470	1,200,000	
Utility		225	240	1,200,000	
Select Structural		1350	1420	1,500,000	(See notes 1 and 3)
No. 1 & Appearance	2x5	1150	1210	1,500,000	
No. 2	and	950	1000	1,400,000	
No. 3	wider	550	580	1,200,000	
Stud		550	580	1,200,000	

DESIGN VALUES FOR JOISTS AND RAFTERS - VISUAL GRADING (Cont)

These "F_b" values are for use where repetitive members are spaced not more than 24 inches. For wider spacing, the "F_b" values should be reduced 13 percent.

Values for surfaced dry or surfaced green lumber apply at 19 percent maximum moisture content in use.

Species and Grade	Size	Design Value in Bending "F _b "		Modulus of Elasticity "E"	Grading Rules Agency
		Joists	Rafters		
EASTERN WHITE PINE (Surfaced dry or surfaced green)					
Select Structural	2x4	1550	1630	1,200,000	Northeastern Lumber Manufacturers Association
No. 1 & Appearance		1350	1420	1,200,000	
No. 2		1100	1160	1,100,000	
No. 3		600	630	1,000,000	
Stud		600	630	1,000,000	
Construction	2x4	800	840	1,000,000	Northern Hardwood & Pine Manufacturers Association
Standard		450	470	1,000,000	
Utility		200	210	1,000,000	
Select Structural	2x5 and wider	1350	1420	1,200,000	(See notes 1 and 3)
No. 1 & Appearance		1150	1210	1,200,000	
No. 2		950	1000	1,100,000	
No. 3		550	580	1,000,000	
Stud		550	580	1,000,000	

EASTERN WHITE PINE (NORTH) (Surfaced dry or surfaced green)					Nat'l. Lumber Grades Auth. (A Canadian Agency - See notes 1, 2 and 3)
Select Structural		1550	1630	1,200,000	
No. 1 & Appearance		1350	1420	1,200,000	
No. 2	2x4	1100	1160	1,100,000	
No. 3		600	630	1,000,000	
Stud		600	630	1,000,000	
Construction		800	840	1,000,000	
Standard	2x4	450	470	1,000,000	
Utility		200	210	1,000,000	
Select Structural	2x5	1350	1420	1,200,000	
No. 1 & Appearance	and	1150	1210	1,200,000	
No. 2	wider	950	1000	1,100,000	
No. 3		550	580	1,000,000	
Stud		550	580	1,000,000	

DESIGN VALUES FOR JOISTS AND RAFTERS - VISUAL GRADING (Cont)

These "F_b" values are for use where repetitive members are spaced not more than 24 inches. For wider spacing, the "F_b" values should be reduced 13 percent.

Values for surfaced dry or surfaced green lumber apply at 19 percent maximum moisture content in use.

Species and Grade	Size	Design Value in Bending "F _b "		Modulus of Elasticity "E"	Grading Rules Agency
		Joists	Rafters		
HEM - FIR (Surfaced dry or surfaced green)					
Select Structural		1900	2000	1,500,000	Western Wood Products Association (See notes 1 and 3)
No. 1 & Appearance		1600	1680	1,500,000	
No. 2		1350	1420	1,400,000	
No. 3	2x4	725	760	1,200,000	
Stud		725	760	1,200,000	
Construction		975	1020	1,200,000	West Coast Lumber Inspection Bureau
Standard	2x4	550	580	1,200,000	
Utility		250	260	1,200,000	
Select Structural		1650	1730	1,500,000	
No. 1 & Appearance	2x5	1400	1470	1,500,000	
No. 2	and	1150	1210	1,400,000	
No. 3	wider	675	710	1,200,000	
Stud		675	710	1,200,000	

NORTHERN PINE (Surfaced dry or surfaced green)					
Select Structural		1850	1940	1,400,000	Northeastern Lumber Manufacturers Association
No. 1		1600	1680	1,400,000	
No. 2	2x4	1300	1370	1,300,000	
No. 3		725	760	1,100,000	
Appearance Stud		1400 725	1470 760	1,400,000 1,100,000	
Construction		950	1000	1,100,000	Northern Hardwood & Pine Manufacturers Association
Standard	2x4	525	550	1,100,000	
Utility		250	260	1,100,000	
Select Structural		1600	1680	1,400,000	(See notes 1 and 3)
No. 1 & Appearance	2x5	1400	1470	1,400,000	
No. 2	and	1100	1160	1,300,000	
No. 3	wider	650	680	1,100,000	
Stud		650	680	1,100,000	

DESIGN VALUES FOR JOISTS AND RAFTERS - VISUAL GRADING (Cont)

These "F_b" values are for use where repetitive members are spaced not more than 24 inches. For wider spacing, the "F_b" values should be reduced 13 percent.

Values for surfaced dry or surfaced green lumber apply at 19 percent maximum moisture content in use.

Species and Grade	Size	Design Value in Bending "F _b "		Modulus of Elasticity "E"	Grading Rules Agency
		Joists	Rafters		
PONDEROSA PINE - SUGAR PINE (PONDEROSA PINE - LODGEPOLE PINE) (Surfaced dry or surfaced green)					
Select Structural	2x4	1650	1730	1,200,000	Western Wood Products Association
No. 1 & Appearance		1400	1470	1,200,000	
No. 2		1150	1210	1,100,000	
No. 3		625	660	1,000,000	
Stud		625	660	1,000,000	
Construction	2x4	825	870	1,000,000	(See notes 1 and 3)
Standard		450	470	1,000,000	
Utility		225	240	1,000,000	
Select Structural	2x5 and wider	1400	1470	1,200,000	
No. 1 & Appearance		1200	1260	1,200,000	
No. 2		975	1020	1,100,000	
No. 3		575	600	1,000,000	
Stud		575	600	1,000,000	

SOUTHERN PINE (Surfaced dry)					Southern Pine Inspection Bureau (See note 3)
Select Structural		2300	2420	1,700,000	
Dense Select Structural		2700	2840	1,800,000	
No. 1		1950	2050	1,700,000	
No. 1 Dense		2300	2420	1,800,000	
No. 2	2x4	1650	1730	1,600,000	
No. 2 Dense		1900	2000	1,600,000	
No. 3		900	950	1,400,000	
No. 3 Dense		1050	1100	1,500,000	
Stud		900	950	1,400,000	
Construction					
Standard	2x4	1150	1210	1,400,000	
Utility		675	710	1,400,000	
		300	320	1,400,000	
Select Structural					
Dense Select Structural		2000	2100	1,700,000	
No. 1		2350	2470	1,800,000	
No. 1 Dense		1700	1790	1,700,000	
No. 1 Dense		2000	2100	1,800,000	
No. 2	2x5 and wider	1400	1470	1,600,000	
No. 2 Dense		1650	1730	1,600,000	
No. 3		800	840	1,400,000	
No. 3 Dense		925	970	1,500,000	
Stud		850	890	1,400,000	

DESIGN VALUES FOR JOISTS AND RAFTERS - VISUAL GRADING (Cont)

These "F_b" values are for use where repetitive members are spaced not more than 24 inches. For wider spacing, the "F_b" values should be reduced 13 percent. Values for surfaced dry or surfaced green lumber apply at 19 percent maximum moisture content in use.

Species and Grade	Size	Design Value In Bending "F _b "		Modulus of Elasticity "E"	Grading Rules Agency
		Joists	Rafters		
SOUTHERN PINE (Surfaced at 15 percent maximum moisture content-MD)					
Select Structural		2500	2630	1,800,000	
Dense Select Structural		2900	3050	1,900,000	
No. 1		2100	2210	1,800,000	
No. 1 Dense		2450	2570	1,900,000	
No. 2	2x4	1750	1840	1,600,000	
No. 2 Dense		2050	2150	1,700,000	Southern
No. 3		975	1020	1,500,000	Blaine
No. 3 Dense		1150	1210	1,500,000	Inspection
Stud		975	1020	1,500,000	Bureau
Construction		1250	1310	1,500,000	
Standard	2x4	725	760	1,500,000	
Utility		300	320	1,500,000	(See note 3)
Select Structural		2750	2860	1,800,000	
Dense Select Structural		2800	2930	1,900,000	
No. 1		1850	1940	1,800,000	
No. 1 Dense	2x5 and wider	2150	2260	1,900,000	
No. 2		1500	1580	1,600,000	
No. 2 Dense		1750	1840	1,700,000	
No. 3		875	920	1,500,000	
No. 3 Dense		1000	1050	1,500,000	
Stud		900	950	1,500,000	

SPRUCE - PINE - FIR (Surfaced dry or surfaced green)					Nat'l. Lumber Grades Auth. (A Canadian Agency - (See notes 1, 2 and 3)
Select Structural		1650	1730	1,500,000	
No. 1 & Appearance		1400	1470	1,500,000	
No. 2	2x4	1150	1210	1,300,000	
No. 3		650	680	1,200,000	
Stud		650	680	1,200,000	
Construction		850	890	1,200,000	
Standard	2x4	475	500	1,200,000	
Utility		225	240	1,200,000	
Select Structural	2x5	1450	1520	1,500,000	
No. 1 & Appearance	and	1200	1260	1,500,000	
No. 2	wider	1000	1050	1,300,000	
No. 3		575	600	1,200,000	
Stud		575	600	1,200,000	

DESIGN VALUES FOR JOISTS AND RAFTERS - VISUAL GRADING (Cont)

These "F_b" values are for use where repetitive members are spaced not more than 24 inches. For wider spacing, the "F_b" values should be reduced 13 percent.

Values for surfaced dry or surfaced green lumber apply at 19 percent maximum moisture content in use.

Species and Grade	Size	Design Value in Bending "F _b "		Modulus of Elasticity "E"	Grading Rules Agency
		Joists	Rafters		
WESTERN HEMLOCK (Surfaced dry or surfaced green)					
Select Structural	2x4	2100	2210	1,600,000	Western Wood Products Association (See notes 1 and 3)
No. 1 & Appearance		1800	1890	1,600,000	
No. 2		1450	1520	1,400,000	
No. 3		800	840	1,300,000	
Stud		800	840	1,300,000	
Construction					
Standard	2x4	1050	1100	1,300,000	West Coast Lumber Inspection Bureau
Utility		600	630	1,300,000	
Construction					
Select Structural	2x5 and wider	1800	1890	1,600,000	
No. 1 & Appearance		1550	1630	1,600,000	
No. 2		1250	1310	1,400,000	
No. 3		750	790	1,300,000	
Stud		750	790	1,300,000	

WHITE WOODS (WESTERN WOODS) (Surfaced dry or surfaced green)					Western Wood Products Association (See notes 1 and 3)
Select Structural		1550	1630	1,100,000	
No. 1 & Appearance	2x4	1300	1370	1,100,000	
No. 2		1050	1100	1,000,000	
No. 3		600	630	900,000	
Stud		600	630	900,000	
<hr/>					
Construction		775	810	900,000	
Standard	2x4	425	450	900,000	
Utility		200	210	900,000	
<hr/>					
Select Structural		1300	1370	1,100,000	
No. 1 & Appearance	2x5	1100	1160	1,100,000	
No. 2	and	925	970	1,000,000	
No. 3	wider	550	580	900,000	
Stud		550	580	900,000	

1. When 2-inch lumber is manufactured at a maximum moisture content of 15% (grade-marked MC-15) and used in a condition where the moisture content does not exceed 15%, the design values shown for "surfaced dry or surfaced green" lumber may be increased 8% for design value in bending " F_b ", and 5% for modulus of elasticity "E".

2. National Lumber Grades Authority is the Canadian rules writing agency responsible for preparation, maintenance and dissemination of a uniform softwood lumber grading rule for all Canadian species.

3. Design values for stud grade in 2x5 and wider size classifications apply to 5-inch and 6-inch widths only.

APPENDIX A

CHAPTER ILHR 22

DETERMINING THE LEVEL OF INSULATION

Two methods are outlined for determining the level of insulation required by section ILHR 22.06 using the following sample dwelling:

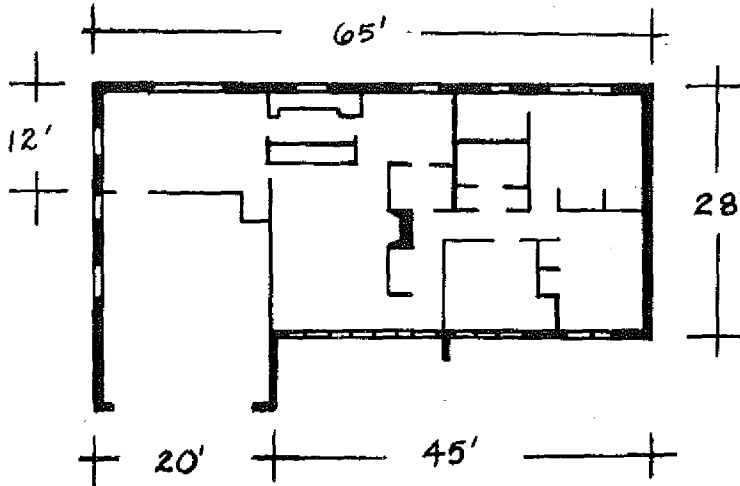

Sample dwelling: 1,500 square feet (186 lineal feet)

Gross wall area = $8.13' \times 186$ lineal feet = 1,512.18 square feet
 Opaque wall area = 1,301.69 square feet (20% framing, 80% cavity)
 Box sill area = $.81' \times 186$ lineal feet = 150.66 square feet
 Exposed foundation wall area = 108.97 square feet
 Basement window area = 15.65 square feet
 Insulated window area = 172.67 square feet
 Insulated door area = 37.82 square feet
 Ceiling area = 1,500 square feet (10% framing, 90% cavity)

METHOD I - ACCEPTABLE PRACTICE METHOD

The acceptable practice method outlined below can be used with minimum calculations for determining the acceptable level of insulation.

Problem: Using the acceptable practice method determine the level of insulation required for the 1,500 square foot dwelling in Phase 1.

Step 1: Determine the percentage window and door area.

$$\begin{aligned} \text{Percent opening area} &= \frac{\text{Window area} + \text{Door area}}{\text{Gross wall area} + \text{Box sill area}} \times 100\% \\ &= \frac{172.67 \text{ sq. ft.} + 37.82 \text{ sq. ft.}}{1512.18 \text{ sq. ft.} + 150.66 \text{ sq. ft.}} \times 100\% \\ &= \frac{210.49 \text{ sq. ft.}}{1,662.84 \text{ sq. ft.}} \times 100\% = 12.66\% \end{aligned}$$

Step 2: Determine level of insulation required for the box sill and side-walls for the given window and door area from Table A-1. (Phase 1)

Using $\frac{5}{8}$ inch plywood siding the table shows that an R-11 batt with R-1.22 fiberboard will allow up to 12.8% window and door area.

Step 3: Determine the percentage window area for the exposed foundation wall.

$$\begin{aligned} \text{Percent opening area} &= \frac{\text{Window area}}{\text{Total exposed foundation area}} \times 100\% \\ &= \frac{15.65 \text{ sq. ft.}}{108.97 \text{ sq. ft.} + 15.65 \text{ sq. ft.}} \times 100\% \\ &= 12.6\% \end{aligned}$$

Step 4: Determine the amount of exposed foundation wall: If there is 8" of wall exposed and the wall height is 8',

$$\text{Percent exposed wall} = \frac{8'' / (12'' \text{ per foot})}{8'} \times 100\% = 8.3\%$$

Step 5: Refer to Table A-2 to determine the level of insulation required for the foundation.

Using the requirements for less than 25% exposed foundation wall the table shows that an R-5.27 insulation can be used for up to 24.8% double glazed windows.

Step 6: Select the level of insulation required for the ceiling from Table A-3.

TABLE A-1
WALL INSULATION GUIDE
(Based on U_o requirements above the foundation wall)

Insulation Type	Percent Window and Door Area					
	Phase I		Phase II (4/1/79)		Phase III (4/1/80)	
	$U_o = .14$		$U_o = .13$		$U_o = .12$	
	$\frac{1}{2}$ inch Plywood Siding	Backed Aluminum Siding	$\frac{1}{2}$ inch Plywood Siding	Backed Aluminum Siding	$\frac{1}{2}$ inch Plywood Siding	Backed Aluminum Siding
R-11 Batt	11.0	12.6	8.9	10.5	6.8	8.4
R-11 Batt, R-1.22 Fiberboard	12.8	14.0	10.8	12.0	8.7	9.9
R-11 Batt, R-5.27 Extruded Polystyrene	16.4	17.0	14.4	15.0	12.4	13.0
R-11 Batt, R-10.54 Extruded Polystyrene	18.8	19.1	16.8	17.2	14.9	15.3
R-13 Batt	12.5	13.9	10.4	11.3	8.3	9.8
R-13 Batt, R-1.22 Fiberboard	14.1	15.4	12.2	13.3	10.3	11.2
R-13 Batt, R-5.27 Extruded Polystyrene	17.0	17.5	15.0	15.6	13.1	13.6
R-13 Batt, R-10.54 Extruded Polystyrene	19.2	19.5	17.3	17.6	15.3	15.6
R-19 Batt	15.3	16.2	13.2	14.2	11.2	12.2
R-19 Batt, R-1.22 Fiberboard	16.4	17.1	14.4	15.1	12.3	13.1
R-19 Batt, R-5.27 Extruded Polystyrene	18.6	19.0	16.7	17.0	14.7	15.1
R-19 Batt, R-10.54 Extruded Polystyrene	20.1	20.4	18.2	18.5	16.3	16.6

Note: The following assumptions were used to derive this table:

1. Door area = 2% of wall and box sill area.
2. Insulated doors are used with a U-value of .47.
3. Insulated windows are used with a U-value of .56.
4. The insulation type is carried down through the box sill.

TABLE A-2
EXPOSED FOUNDATION INSULATION

Foundation exposure	Requirement	Insulation type	Percent window area	
			Single glazed	Double glazed
Less than 25% of foundation exposed	$U_o = .25$	R-5.27	10.4	24.8
		R-11 batt	15.5	34.2
		Multi-cell insul. block (R-12.06)	16.0	35.0
More than 25% of foundation exposed	$U_o = .14$	R-11 batt	4.9	10.8
		R-13 batt	5.8	12.7
		Multi-cell insul. block (R-12.06)	5.5	12.0
	$U_o = .13$	R-11 batt	3.9	8.7
		R-13 batt	4.8	10.6
		Multi-cell insul. block (R-12.06)	4.5	9.9
	$U_o = .12$	R-11 batt	3.0	6.7
		R-13 batt	3.9	8.5
		Multi-cell insul. block (R-12.06)	3.5	7.8

TABLE A-3
INSULATION LEVELS REQUIRED TO MEET CEILING U VALUES

U_o Value	Insulation	R-Value Required	
		In Cavity	Over Framing
.033	Fiber glass batt	R-19 and R-13	R-13
	Fiber glass blown	12 in. (R-30)	6.4 in. (R-16)
	Rock wool	9.7 in. (R-29)	4.2 in. (R-13)
	Cellulose	8.4 in. (R-31)	2.9 in. (R-11)
.029	Fiber glass batt	R-38	R-19
	Fiber glass blown	13.6 in. (R-34)	8.1 in. (R-20)
	Rock wool	10.9 in (R-33)	5.4 in. (R-16)
	Cellulose	9.5 in. (R-35)	4.0 in. (R-15)

Note: The following assumptions are used:
 1. Fiber glass blown = R-2.5 per inch
 2. Rock wool = R-3.0 per inch
 3. Cellulose = R-3.7 per inch

METHOD II — SYSTEM DESIGN METHOD

The system design method is the more complex method of determining the level of insulation required by the code. This procedure may be used when it becomes necessary to combine various materials to comply with the code. If the window area is increased and the same wall insulation is

used, the wall section will not meet the requirements of section ILHR 22.06 (6), but the system design method can be used by adding extra insulation elsewhere.

Problem: Using the system design method, increase the opening area to 15% and determine compliance by adding extra insulation to the walls and ceiling.

Step 1: Determine the inside and outside design temperatures from Tables 22.04-A and B.

Inside temperature = 70° F

Outside temperature = -20° F

$\Delta T = T_{\text{inside}} - T_{\text{outside}} = 70 - (-20) = 90^\circ \text{ F}$.

Note: Degree days may be used for system design instead of design temperatures:

Zone 1, 9,000 degree days

Zone 2, 8,000 degree days

Zone 3, 7,500 degree days

Zone 4, 7,000 degree days

Step 2: Using section ILHR 22.06, determine the insulation values for the exterior walls above grade and the roof/ceiling for Phase I.

Exposed exterior walls above grade; $U_o = .15$

Roof/ceiling; $U_o = .033$

Step 3: Fill in the worksheet to determine requirements for building enclosure heat loss.

Step 4: Select the levels of insulation to be used and determine the U values for the ceiling, wall, box sill and foundation (shown in Figure A-1). Fill in the building enclosure worksheet.

Step 5: If the total heat loss determined through the system design method is within one percent or is less than the heat loss determined through the code requirements, the code has been satisfied.

R-VALUE DETERMINATION BY COMPONENT

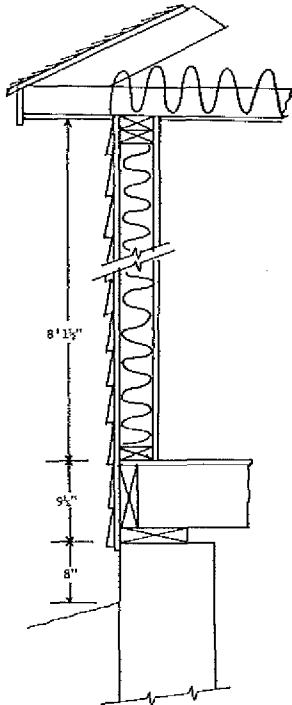

Figure A-1

<u>Ceiling</u>	<u>Cavity R</u>	<u>Joist R</u>
Top surface	.17	.17
Insulation	38.0	19.0
Wood	—	6.88
1/2" gyp. wall board	.45	.45
Bottom surface	.61	.61
	39.23	27.11
	(U = .025)	(U = .037)
<u>Wall</u>	<u>Cavity R</u>	<u>Stud R</u>
Outside surface	.17	.17
1/2" ext. siding	.77	.77
Rigid insulation	—	—
Insulation	11.00	—
Wood stud	—	4.38
1/2" gyp. wall board	.45	.45
Inside surface	.68	.68
	13.07	6.45
	(U = .070)	(U = .13)
<u>Box sill</u>	<u>R</u>	
Outside surface	.17	
1/2" ext. siding	.77	
Rigid insulation	—	
Insulation	11.00	
1 1/2" wood	1.88	
Inside surface	.68	
	14.50	
	(U = .064)	
<u>Foundation</u>	<u>R</u>	
Outside surface	.17	
8" concrete	.64	
Inside surface	.68	
Rigid insulation	5.27	
	6.76	
	(U = .15)	

WORKSHEET FOR SYSTEM DESIGN ANALYSIS

CODE REQUIREMENTS				
Component	U _o Reqd.	Area	ΔT	Heat Loss
Walls				
Above grade	.15	1512.18	90	20,414.4
Box sill	.15	150.66	70	1,581.9
Foundation	.15	124.62	70	1,308.5
Roof/Ceiling	.033	1500.00	90	4,455.0
Floor				
Over unheated spaces				
Slab-on-grade				
TOTAL				27,759.9

SYSTEM DESIGN ALTERNATIVE				
Component	U	Area	ΔT	Heat Loss
Walls				
Cavity	.070	1010.20	90	6,364.3
Solid	.13	252.60	90	2,955.4
Box sill	.064	150.66	70	675.0
Foundation	.15	108.97	70	1,114.2
Roof/Ceiling				
Cavity	.025	1350.00	90	3,037.5
Solid	.037	150.00	90	499.5
Floor				
Over unheated spaces				
Slab-on-grade				
Windows	.56	211.61	90	10,665.1
Doors	.31	37.82	90	1,055.2
Basement windows	1.13	15.65	70	1,237.9
TOTAL				27,634.1

WORKSHEET FOR SYSTEM DESIGN ANALYSIS

CODE REQUIREMENTS				
Component	U_0 Req.	Area	ΔT	Heat Loss
Walls				
Above grade				
Box sill				
Foundation				
Roof/Ceiling				
Floor				
Over unheated spaces				
Slab-on-grade				
TOTAL				

SYSTEM DESIGN ALTERNATIVE				
Component	U	Area	ΔT	Heat Loss
Walls				
Cavity				
Solid				
Box sill				
Foundation				
Roof/Ceiling				
Cavity				
Solid				
Floor				
Over unheated spaces				
Slab-on-grade				
Windows				
Doors				
Basement windows				
TOTAL				

TABLE A-1
COMMON CONSTRUCTION MATERIAL R-VALUES*

Material	Description	Density (lb per cu ft)	Per inch	For thick-
			thickness R-Value	ness listed R-Value
BUILDING	Asbestos-cement board.....	120	0.25	—
BOARD Boards,	Asbestos-cement			
panels,	board ½ in.	120	—	0.03
subflooring,	Asbestos-cement			
sheathing,	board ½ in.	120	—	0.06
woodbased panel	Gypsum or plaster			
products	board ¾ in.	60	—	0.32
	Gypsum or plaster			
	board ½ in.	50	—	0.45
	Plywood.....	34	1.25	—
	Plywood..... ¼ in.	34	—	0.31
	Plywood..... ⅜ in.	34	—	0.47
	Plywood..... ½ in.	34	—	0.62
	Plywood or wood			
	panels ¾ in.	34	—	0.93
	Insulating board			
	Sheathing, reg.			
	density ½ in.	18	—	1.32
 25/32 in.	18	—	2.06
	Sheathing, intermediate			
	density ½ in.	22	—	1.22
	Nail-base			
	sheathing..... ½ in.	25	—	1.14
	Shingle backer ¾ in.	18	—	0.94
	Shingle backer..... 5/16 in.	18	—	0.78
	Sound deadening			
	board ½ in.	15	—	1.35
	Tile and lay-in panels,			
	plain or acoustic.....	18	2.50	—
 ½ in.	18	—	1.25
 ¾ in.	18	—	1.89
	Laminated paperboard.....	30	2.00	—
	Homogeneous board from			
	re-pulped paper.....	30	2.00	—
	Hardboard			
	Medium density			
	siding 7/16 in.	40	—	0.67
	Other medium density.....	50	1.37	—
	High density, underlay.....	55	1.22	—
	High density std. tempered ..	63	1.00	—
	Particleboard			
	Low density.....	37	1.85	—

Register, February, 1985, No. 350

Material	Description	Density (lb per cu ft)	Per inch thickness R-Value	For thick- ness listed R-Value
	Medium density	50	1.06	—
	High density	62.5	0.85	—
	Underlayment ½ in.	40	—	0.82
	Wood subfloor..... ¾ in.	—	—	0.94
BUILDING PAPER	Vapor-permeable felt.....	—	—	0.06
	Vapor-seal, 2 layers of mopped 15 lb. felt	—	—	0.12
	Vapor-seal, plastic film.....	—	—	Negl.
ROOF INSULATION	Preformed, for use above deck			
	Approximately ½ in.	—	—	1.39
	Approximately 1 in.	—	—	2.78
	Approximately 1½ in.	—	—	4.17
	Approximately 2 in.	—	—	5.56
	Approximately 2½ in.	—	—	6.67
	Approximately 3 in.	—	—	8.33
	Cellular glass.....	9	2.50	—
MASONRY MATERIALS Concrete	Cement mortar	116	0.20	—
	Gypsum-fiber concrete			
	87½% gypsum, 12½% wood chips	51	0.60	—
	Lightweight aggregates	120	0.19	—
	Including expanded shale,	100	0.28	—
	clay or slate, expanded	80	0.40	—
	slags; cinders; pumice;	60	0.59	—
	vermiculite; also cellular	40	0.86	—
	concretes	30	1.11	—
		20	1.43	—
	Perlite.....	40	1.08	—
	30	1.41	—
	20	2.00	—
	Sand and gravel or stone ag- gregate (oven dried).....	140	0.11	—
	Sand and gravel or stone ag- gregate (not dried).....	140	0.08	—
Stucco.....	116	0.20	—	
MASONRY UNITS	Brick, common.....	120	0.20	—
	Brick, face.....	130	0.11	—
	Clay tile, hollow:			
	1 cell deep 3 in.	—	—	0.80
	1 cell deep 4 in.	—	—	1.11
	2 cells deep..... 6 in.	—	—	1.52
	2 cells deep..... 8 in.	—	—	1.85
	2 cells deep..... 10 in.	—	—	2.22
	3 cells deep..... 12 in.	—	—	2.50
	Concrete blocks, 3 oval core:			
	Sand & gravel			
	aggregate..... 4 in.	—	—	0.71
 8 in.	—	—	1.11
 12 in.	—	—	1.28
	Cinder aggregate ... 3 in.	—	—	0.86
 4 in.	—	—	1.11
 8 in.	—	—	1.72
 12 in.	—	—	1.89
Lightweight	3 in.	—	1.27	
aggregate(expanded	4 in.	—	1.50	
shale, clay, slate	8 in.	—	2.00	
or slag; pumice)	12 in.	—	2.27	
Concrete blocks, rectangular core				
Sand & gravel				
aggregate				
2 core, 8" 36 lb	—	—	1.04	

Material	Description	Density lb per cu ft)	Per inch thickness R-Value	For thick ness listed R-Value
	Same with filled cores	—	—	1.93
	Lightweight aggregate (expanded shale, clay, slate or slag, pumice):			
	3 core, 6" 19 lb	—	1.65	
	Same with filled cores	—	2.99	
	2 core, 8" 24 lb	—	2.18	
	Same with filled cores	—	5.03	
	3 core, 12" 38 lb	—	2.48	
	Same with filled cores	—	5.82	
	Stone, lime or sand	—	0.08	—
	Gypsum partition tile:			
	3 x 12 x 30 in. solid	—	—	1.26
	3 x 12 x 30 in. 4-cell	—	—	1.35
	4 x 12 x 30 in. 3-cell	—	—	1.67
PLASTERING MATERIALS	Cement plaster, sand aggregate	116	0.20	—
	Sand aggregate ¾ in.	—	—	0.08
	Sand aggregate ¾ in.	—	—	0.15
	Gypsum plaster:			
	Lightweight aggregate ½ in.	45	—	0.32
	Lightweight aggregate ¾ in.	45	—	0.39
	Lightweight aggregate on metal lath ¾ in.	—	—	0.47
	Perlite aggregate	45	0.67	—
	Sand aggregate	105	0.18	—
	Sand aggregate ½ in.	105	—	0.09
	Sand aggregate ¾ in.	105	—	0.11
	Sand aggregate on metal lath ¾ in.	—	—	0.1
	Vermiculite aggregate	45	0.59	—
ROOFING	Asbestos-cement shingles	120	—	0.21
	Asphalt roll roofing	70	—	0.15
	Asphalt shingles	70	—	0.44
	Built-up roofing ¾ in.	70	—	0.33
	Slate ½ in.	—	—	0.05
	Wood shingles, plain plastic film faced	—	0.94	—
SIDING MATERIALS (On flat surface)	Shingles:			
	Asbestos-cement	120	—	0.21
	Wood, 16", 7½" exposure	—	—	0.87
	Wood, double, 16", 12" exposure	—	—	1.19
	Wood, plus insulating backer board 5/16 in.	—	—	1.40
	Siding:			
	Asbestos-cement, ¼" lapped	—	—	0.21
	Asphalt roll siding	—	—	0.15
	Asphalt insulating siding (½" bd.)	—	—	1.46
	Wood drop 1 x 8"	—	—	0.79
	Wood bevel, ½" x 8" lapped	—	—	0.81

Material	Description	Density (lb per cu ft)	Per inch thickness R-Value	For thick- ness listed R-Value
	Wood bevel, $\frac{3}{4}$ x 10" lapped.....	—	—	1.05
	Wood plywood $\frac{3}{4}$ " lapped.....	—	—	0.59
	Aluminum or steel, over sheathing, hollow-backed.....	—	—	0.61
	Insulating-board backed nominal $\frac{3}{4}$ ".....	—	—	1.82
	Insulating-board backed nominal $\frac{3}{4}$ " foil backed.....	—	—	2.96
	Architectural glass.....	—	—	0.10
FINISH FLOORING MATERIALS	Carpet and fibrous pad.....	—	—	2.08
	Carpet and rubber pad.....	—	—	1.23
	Cork tile..... $\frac{3}{4}$ in.	—	—	0.28
	Terrazzo..... 1 in.	—	—	0.08
	Tile-asphalt, linoleum, vinyl, rubber.....	—	—	0.05
	Wood, hardwood finish..... $\frac{3}{4}$ in.	—	—	0.08
INSULATING MATERIALS Blanket and batt	Mineral fiber, fibrous form processed from rock, slag or glass			
	Approx. 2 to 2 $\frac{3}{4}$ "... Note 1	—	—	7
	Approx. 3 to 3 $\frac{1}{2}$ "... Note 1	—	—	11
	Approx. 5 $\frac{1}{2}$ to 6 $\frac{1}{2}$ "..... Note 1	—	—	19
Board and Slabs	Cellular glass.....	9	2.50	—
	Glass fiber, organic bonded.....	4-9	4.00	—
	Expanded rubber (rigid).....	4.5	4.55	—
	Expanded polystyrene ex- truded, plain.....	1.8	4.00	—
	Expanded polystyrene ex- truded (R-12 exp.).....	2.2	5.00	—
	Expanded polystyrene ex- truded (R-12 exp.) (Thickness 1" and greater).....	3.5	5.26	—
	Expanded polystyrene, molded beads.....	1.0	3.57	—
	Expanded polyurethane (R-11 exp.).....	1.5	6.25	—
	Mineral fiber with resin binder.	15	3.45	—
	Mineral fiberboard wet felted			
	Core or roof insulation.....	16-17	2.94	—
	Acoustical tile.....	18	2.86	—
	Acoustical tile.....	21	2.70	—
	Mineral fiberboard wet molded			
	Acoustical tile	23	2.38	—
	Wood or cane fiberboard			
	Acoustical tile..... $\frac{1}{2}$ in.	—	—	1.25
	Acoustical tile..... $\frac{3}{4}$ in.	—	—	1.89
	Interior finish (plank, tile).....	15	2.86	—
	Insulating roof deck			
Approximately..... 1 $\frac{1}{2}$ in.	—	—	4.17	
Approximately..... 2 in.	—	—	5.56	
Approximately..... 3 in.	—	—	8.33	
Wood shredded (cemented in preformed slabs).....	22	1.67	—	
Loose Fill	Cellulose insulation (milled paper or wood pulp)	2.5-3	3.70	—
	Sawdust or shavings	0.8-1.5	2.22	—
	Wood fiber, softwoods	2.0-3.5	3.33	—
	Perlite, expanded	5.0-8.0	2.70	—

Material	Description	Density lb per cu ft)	Per inch thickness R-Value	For thick ness listed R-Value
	Mineral fiber (rock, slag or glass):			
	Approximately 3"..... Note 1	8-15	—	9
	Approximately 4½"..... Note 1	8-15	—	13
	Approximately 6¾"..... Note 1	8-15	—	19
	Approximately 7¾"..... Note 1	8-15	—	24
	Silica aerogel.....	7.6	5.88	—
	Vermiculite (expanded).....	7.0-8.2	2.13	—
	4.0-6.0	2.27	—
WOODS	Maples, oak and similar hardwoods.....	45	0.91	—
	Fir, pine, and similar softwoods.....	32	1.25	—
	Fir, pine, and similar softwoods..... ¾ in.	32	—	0.94
 1½ in.	32	—	1.89
 2½ in.	32	—	3.12
 3½ in.	32	—	4.85

Note 1: R-value varies with fiber diameter. Insulation is produced by different densities; therefore, there is a wide variation in thickness for the same R-value between various manufacturers. (See Batt and Loose Fill Insulation.)

*Reprinted with permission from ASHRAE Handbook of Fundamentals 1972.

TABLE A-5
 COEFFICIENTS OF TRANSMISSION (U) OF WINDOWS, SKYLIGHTS, AND LIGHT TRANSMITTING PARTITIONS*
 (These values are for heat transfer from air to air)
 Btu per (hr) (sq ft) (F Deg)

PART A
 VERTICAL PANELS (EXTERIOR WINDOWS, SLIDING PATIO DOORS
 AND PARTITIONS)—FLAT GLASS, GLASS BLOCK AND PLASTIC
 SHEET

Description	Exterior ¹		Interior
	Winter	Summer	
Flat Glass			
single glass	1.13	1.06	0.73
insulating glass—double ²			
3/16 in. air space	0.69	0.64	0.51
¼ in. air space	0.65	0.61	0.49
½ in. air space	0.58	0.56	0.46
½ in. air space, low emissivity coating ³			
emissivity = 0.20	0.38	0.36	0.32
emissivity = 0.40	0.45	0.44	0.38
emissivity = 0.60	0.52	0.50	0.42
insulating glass—triple ²			
¼ in. air spaces	0.47	0.45	0.38
½ in. air spaces	0.36	0.35	0.30
storm windows			
1 in.-4 in. air space	0.56	0.54	0.44
Glass Block ⁴			
6 x 6 x 4 in. thick	0.60	0.57	0.46
8 x 8 x 4 in. thick	0.56	0.54	0.44
—with cavity divider	0.48	0.46	0.38
12 x 12 x 4 in. thick	0.52	0.50	0.41
—with cavity divider	0.44	0.42	0.36
12 x 12 x 2 in. thick	0.60	0.57	0.46
Single Plastic Sheet	1.09	1.00	0.70

¹See Part C for adjustment for various window and sliding patio door types.

²Double and triple refer to the number of lights of glass.

³Coating on either glass surface facing air space; all other glass surfaces uncoated.

⁴Dimensions are nominal.

*Reprinted with permission from ASHRAE Handbook of Fundamentals.

PART B
 HORIZONTAL PANELS (SKYLIGHTS)
 FLAT GLASS, GLASS BLOCK AND PLASTIC BUBBLES

Description	Exterior ¹		Interior ²
	Winter ³	Summer ³	
Flat Glass			
single glass	1.22	0.83	0.96
insulating glass—double ²			
3/16 in. air space	0.75	0.49	0.62
¼ in. air space	0.70	0.46	0.59
½ in. air space	0.66	0.44	0.56
½ in. air space, low emissivity coating ³			
emissivity = 0.20	0.46	0.31	0.39
emissivity = 0.40	0.53	0.36	0.45
emissivity = 0.60	0.60	0.40	0.50
Glass Block ⁴			
11 x 11 x 3 in. thick with cavity divider	0.53	0.35	0.44
12 x 12 x 4 in. thick with cavity divider	0.51	0.34	0.42
Plastic Bubbles ⁷			
single walled	1.15	0.80	—
double walled	0.70	0.46	—

¹For heat flow up.

²For heat flow down.

⁷Based on area of opening, not total surface area.

(See following page for Part C of this table.)

PART C
ADJUSTMENT FACTORS FOR VARIOUS WINDOW AND SLIDING PATIO DOOR
TYPES
 (Multiply U values in Parts A and B by these factors)

Description	Single Glass	Double or Triple Glass	Storm Windows
Windows			
All Glass ^a	1.00	1.00	1.00
Wood Sash—80% Glass	0.90	0.95	0.90
Wood Sash—60% Glass	0.80	0.85	0.80
Metal Sash—80% Glass	1.00	1.20	1.20 ^b
Sliding Patio Doors			
Wood Frame	0.95	1.00	—
Metal Frame	1.00	1.10	—

^aRefers to windows with negligible opaque area.

^bValue becomes 1.00 when storm sash is separated from prime window by a thermal break.

TABLE A-6
COEFFICIENTS OF TRANSMISSION (U) FOR SLAB DOORS*
 Btu per (hr) (sq ft) (F Deg)

Thickness ¹	Winter			Summer, No Storm Door
	Solid Wood, No Storm Door	Storm Door ²		
		Wood	Metal	
1 in.	0.64	0.30	0.39	0.61
1¼ in.	0.55	0.28	0.34	0.53
1½ in.	0.49	0.27	0.33	0.47
2 in.	0.43	0.24	0.29	0.42
Steel Door				
1¾ in.				
A ³	0.59	—	—	0.58
B ⁴	0.40	—	—	0.39
C ⁵	0.47	—	—	0.46

¹Nominal thickness.

²Values for wood storm doors are for approximately 50% glass; for metal storm doors values apply for any percent of glass.

³A = Mineral fiber core (2 lb/cu ft).

⁴B = Solid urethane foam core.

⁵C = Solid polystyrene core.

Note: Hollow core doors 1¾ in. thick - R = 2.17; U = 0.46
 1¾ in. thick - R = 2.22; U = 0.45

*Reprinted with permission from ASHRAE Handbook of Fundamentals.

APPENDIX B

FORMULA FOR DETERMINING
THE OVERALL U_o
OF THE WALL

$$U_o = \frac{U_{cav} A_{cav} + U_{sol} A_{sol} + U_{win} A_{win} + U_{door} A_{door} + U_{box} A_{box} + U_{found} A_{found}}{A_o}$$

Where:

- U_o = Average thermal transmittance of gross wall area
 A_o = Gross area of exterior walls.
 U_{cav} = Thermal transmittance of cavity area (usually assume 80%)
 A_{cav} = Area between wall framing where insulation may be placed.
 U_{sol} = Thermal transmittance of wood framing area.
 A_{sol} = Area of wood framing (usually assume 20%)
 U_{box} = Thermal transmittance of box sill area.
 A_{box} = Area of box sill
 U_{found} = Thermal transmittance of foundation area.
 A_{found} = Area of above grade exposed concrete.
 U_{win} = Thermal transmittance of window.
 A_{win} = Total glass area.
 U_{door} = Thermal transmittance of door.
 A_{door} = Total door area.

FORMULA FOR DETERMINING
THE OVERALL U_o
OF THE CEILING

$$U_o = \frac{U_{cav} A_{cav} + U_{sol} A_{sol} + U_{skylight} A_{skylight}}{A_o}$$

Where:

- U_o = Average thermal transmittance of gross roof/ceiling.
 A_o = Gross area of roof/ceiling assembly.
 U_{cav} = Thermal transmittance of cavity area.
 A_{cav} = Area between wood framing.
 U_{sol} = Thermal transmittance of framing.
 A_{sol} = Area of wood framing (usually assume 10%)
 $U_{skylight}$ = Thermal transmittance of skylight elements.
 $A_{skylight}$ = Area of skylight (including frame).

APPENDIX C

INSULATION, EQUIPMENT
AND CONDENSATION CONTROL

This appendix is a guide for the proper installation of insulation. The preceding appendices indicated the required amounts and types of insulation necessary to provide the various thermal resistance values for the Register, February, 1985, No. 350

building envelope. In order to attain the resistance values specified, it is important that the insulation be properly installed. This appendix includes types of materials currently available and common application practices.

Condensation control should be provided in the form of vapor barriers and thermal breaks. Vapor barriers should be installed on the warm side (area heated in winter) of all walls, ceilings, and insulated floors. All metal window, skylight, and door frames should contain a thermal break.

Insulation is manufactured in many forms and types. The most commonly used materials in residential construction are batts and blankets, rigid insulation, reflective insulation, loose fill, and sprayed insulation. The following is a list of types of materials and the federal specifications governing their characteristics.

Cork board	FS HH-I-561
Cellular glass	FS HH-I-551
Duct insulation	FS HH-I-558b
Expanded polystyrene insulation board	FS HH-I-524
Fiberboard	FS LLL-I-535 or ASTM C-208 Class C
Insulation board (urethane)*	FS HH-I-530
Insulation, thermal (perlite)	FS HH-I-574
Mineral fiber, pneumatic or poured	FS HH-I-1030A
Mineral fiber, insulation blanket	FS HH-I-521E
Perlite	FS HH-I-526a
Perimeter insulation	FS HH-I-524a
	Type II
.....	FS HH-I-558b Form A, Class 1 or 2
Reflective, thermal	FS HH-I-1552
Structural fiberboard insulation roof deck ...	AIMA IB Spec. No. 1
Cellulose; vegetable or wood fiber	FS HH-I-515b-25
Vermiculite	FS HH-I-585
Vermiculite, water repellent loose fill	FHA UM-30
Mineral fiber, roof insulation	HH-I-526c

BATTS AND BLANKETS

These materials are usually identified on the package and on the vapor barrier facing with their "R" values. Under the federal specifications, there are 3 standard products identified as R-7, R-11, and R-19. These values are based on the insulation value of the mass. Some manufacturers offer other products such as R-8, R-13 and R-22. The specific thickness of insulation required for a specific "R" value may vary from one manufacturer to another due to differences in base materials and manufacturing processes.

General Guidelines

1. Install insulation so the vapor barrier faces the interior of the dwelling.
2. Vapor barriers should not be left exposed.
3. Insulate all voids of the building envelope including small spaces, gaps, around receptacles, pipes, etc.

4. Place insulation on the cold side of pipes and ducts (see Fig. 4). Insulation is not required for supply and return air ducts in heated basements and cellars.

Ceilings

There is a variety of methods for installing blanket insulation in ceilings.

1. Fastening from below (Fig. 1b).
2. Installing unfaced (without a vapor barrier), friction-fit blankets (Fig. 2).
3. Laying the insulation in from above when the ceiling finish material is in place (Fig. 1a).

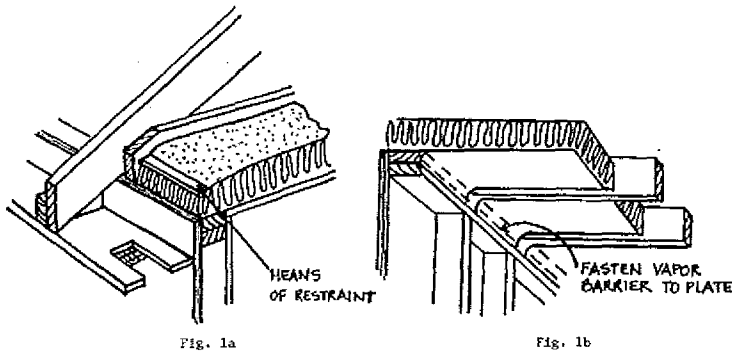
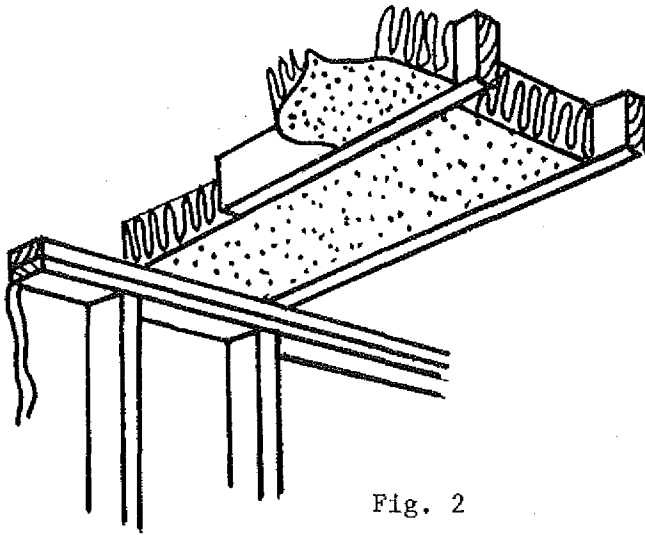

Fig. 1a

Fig. 1b

Fasten flanges to the inside of ceiling joists as shown in Fig. 1b. Extend the insulation entirely across the top plate, keeping the blanket as close to the plate as possible. Fasten vapor barrier to plate. When eave vents are used, the insulation should not block air movement from eave to space above insulation (Fig. 1a).



Insert friction-fit blankets between ceiling joists (Fig. 2). Allow insulation to overlap the top plate of the exterior wall, but not enough to block eave ventilation. The insulation should be in contact with the top of the plate to avoid heat loss and air infiltration beneath the insulation. The required vapor barrier is not shown.

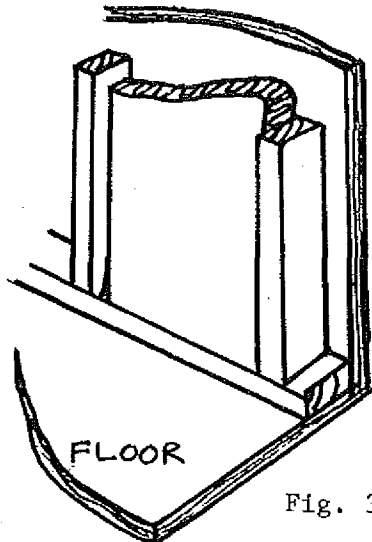

Insert blankets into stud spaces. Working from the top down, space fasteners per manufacturers recommendations, fitting flanges tightly

against face of stud (Fig. 3). Cut blankets slightly over length and fasten the vapor barrier to the top and bottom plates.

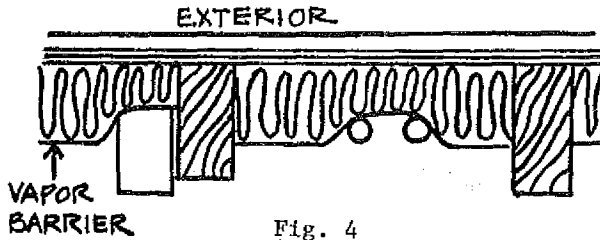

Fig. 4

Insert insulation behind (cold side in winter) pipes, ducts, and electrical boxes (Fig. 4).

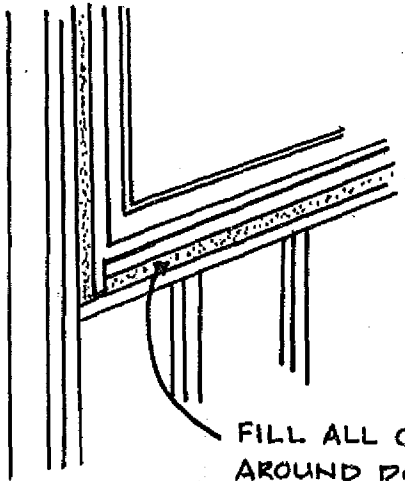

Fig. 5

**FILL ALL CRACKS
AROUND DOORS AND WINDOWS
(COVER WITH VAPOR BARRIER)**

Fill small spaces between rough framing and door and window heads, jambs and sills with pieces of insulation (Fig. 5).

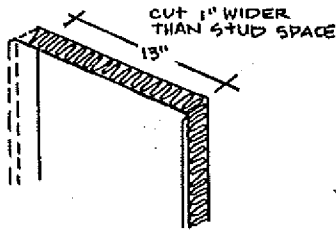

Fig. 6a

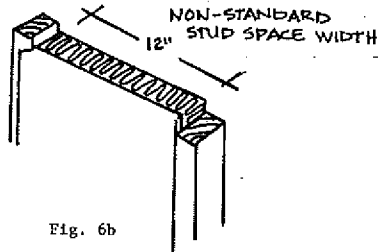

Fig. 6b

Insulate nonstandard-width stud or joist spaces by cutting the insulation and vapor barrier an inch or so wider than the space to be filled (Fig. 6a). Pull the vapor barrier on the cut side to the other stud, compressing the insulation behind it, and fasten through vapor barrier to stud face (Fig. 6b). Unfaced blankets are cut slightly oversize and fitted into place.

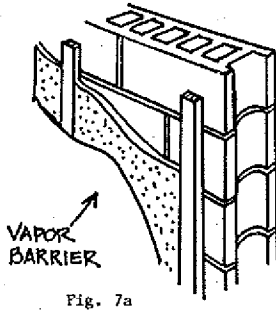

Fig. 7a

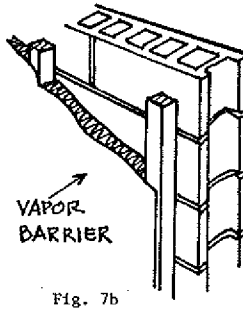

Fig. 7b

Masonry walls may be insulated by inserting insulation between furring strips spaced at 16 or 24 inches o.c. (Fig. 7a and 7b). It is recommended to apply the vapor barrier to the inside surface.

Floor and Crawl Spaces

Fig. 8a

Fig. 8b

Floors over crawl spaces (Fig. 8a) should be insulated either by insulating the foundation walls or by placing insulation on or between the joists. Insulation should be securely fastened. In all cases, the vapor barrier side of the insulation should face the floor above; that is, be adjacent to the warm side in winter. A vapor barrier should be used to cover the ground.

Dropped Soffits

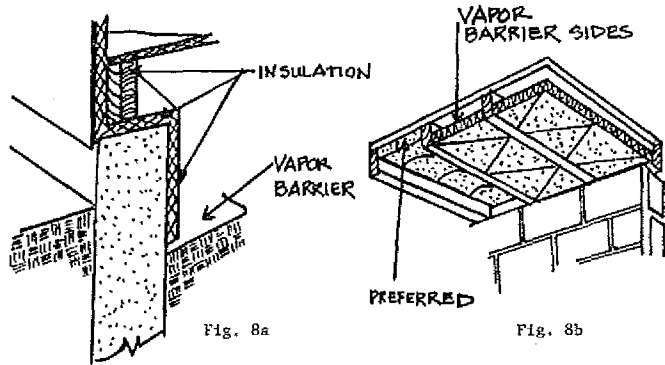
Insulation of dropped soffits over kitchen cabinets, bathtubs, showers, or similar areas, need special attention when they are exposed to the attic. If the dropped soffit is framed before ceiling finish material is applied, a "board" (plywood, hardboard, gypsumboard, etc.) should be installed over the cavity to support insulation.

In multiple dwellings with back-to-back kitchens or baths, it is necessary to extend ceiling finish material over dropped soffits to the party wall to avoid loss of acoustical control and to provide adequate fire stops.

Rigid Insulation

Rigid insulation is available in various sizes and thicknesses made of polystyrene, polyurethane, cork, cellular glass, mineral fiber (glass or rock wool), perlite, wood fiberboard, etc. They are used as insulation for masonry construction, as perimeter insulations around concrete slabs, as exterior sheathing under the weather barrier, as rigid insulations on top of roof decks, and other applications. Rigid insulations, such as polystyrene and polyurethane, are vapor barriers and, in most applications, will not require the installation of a separate barrier.

Installation Procedures

Masonry walls: Rigid insulations are applied to either face of a masonry wall (Fig. 9a and 9c) or are used as a cavity insulation between two wythes of masonry (Fig. 9b). When applied to the face of masonry walls, they are generally installed with adhesive and/or mechanical fasteners. The manufacturer's recommendation should be followed.

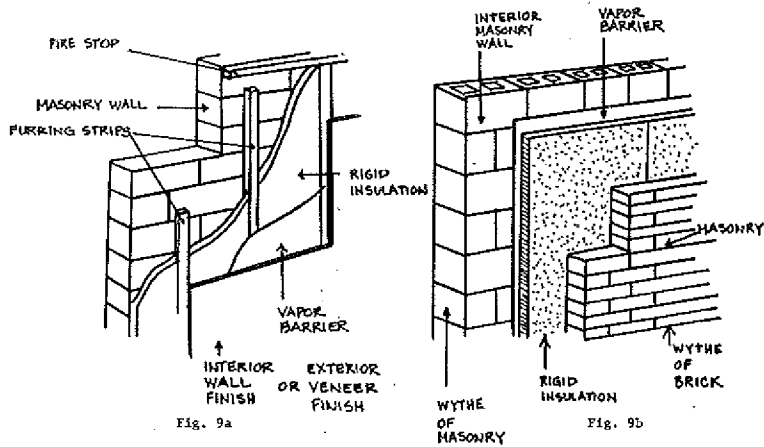

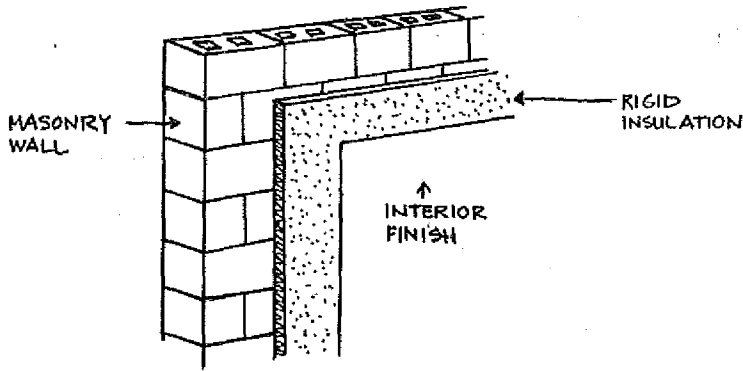

Fig. 9c

Frame Construction: When rigid insulation is used with frame construction (Fig. 10), it is usually applied as sheathing to the outside of the framing, and mechanically attached with nails to wood studs or to metal studs with screws or clips or other approved methods.

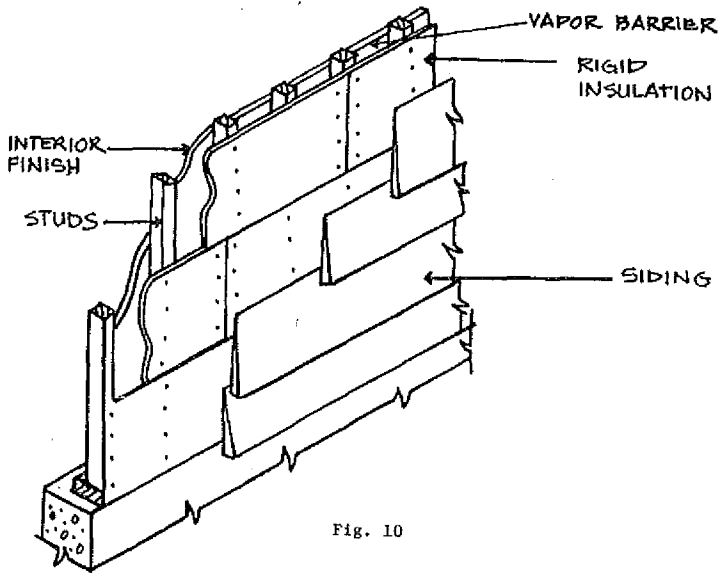

Fig. 10

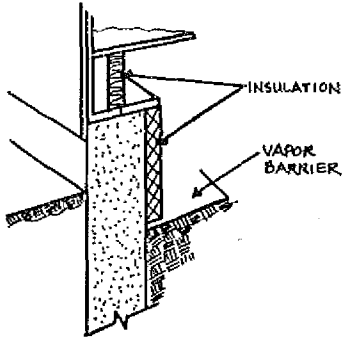

Fig. 11a

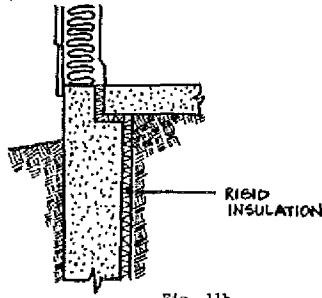

Fig. 11b

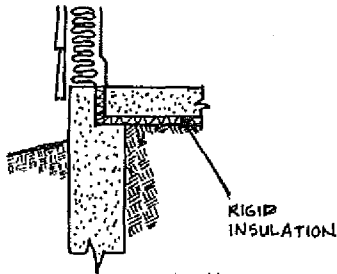

Fig. 11c

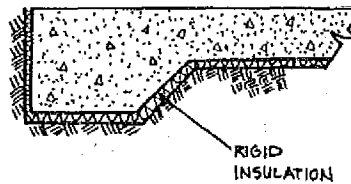

Fig. 11d

Roof Insulation: Roof insulation boards are usually installed with an approved adhesive, hot asphalt, or may be nailed to the roof sheathing. The manufacturer's instructions should be followed.

Slab-on-Grade: Rigid insulation is frequently used as insulation around the perimeter of concrete slabs-on-grade (Fig. 11b, c, d) and also may be used on the inside of foundation walls adjacent to heated crawl spaces, basements or cellars (Fig. 11a). Installation is usually accomplished with adhesive and/or mechanical fasteners. Perimeter insulation should be installed against the foundation wall or extended into the interior of the building to a distance equal to the design frost line (Fig. 11b, c and d). Where the slab bears on the foundation ledge, the insulation should be a load-bearing type.

INSULATED CONCRETE BLOCK

Concrete block manufacturers are currently producing several types of multi-celled block with improved insulating values. The thermal resistance of the block will vary depending upon the types of insulation used and the configuration of the cells. An example of a typical multi-celled block is shown below.

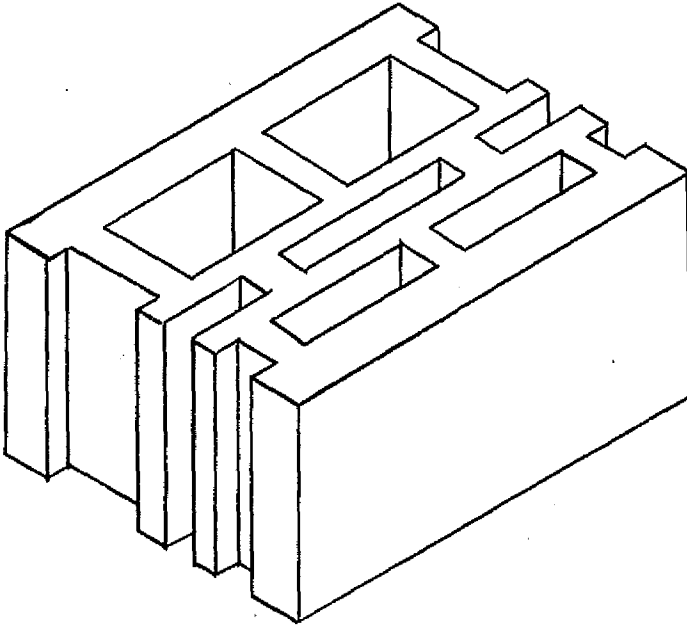

LOOSE FILL INSULATION

Materials of this type are those made from mineral fibers (rock or glass), cellulose materials (wood fibers or shredded paper), or other manufactured products that can easily be poured.

BLOWN ATTIC INSULATION

There are several factors pertaining to blown attic insulation that can cause differences in its installed thermal resistance value (R). For a given manufacturer's insulation, the installed thermal resistance (R) value depends on thickness and weight of insulating material applied per square foot. Federal specification HH-I-1030A for insulation requires that each bag of insulation be labeled to show the minimum thickness, the maxi-

imum net coverage, and the minimum weight of (that particular) insulation material required per square foot to produce resistance values of R-30, 22, 19, and 11. A bag label example for blown insulation is shown in Fig. 12.

The number of bags of blown insulation required to provide a given R-value to insulate an attic of a given size may be calculated from data provided by the manufacturer. If only the thickness of blown attic insulation is specified, and the density or number of bags is not, the desired or assumed thermal resistance (R) value may not be achieved. The important characteristic is weight per square foot. Thickness is the minimum thickness, not the average thickness experienced in the field.

Adequate baffling of the vent opening or insulation blocking should be provided so as to deflect the incoming air above the surface of the installed blown or poured insulation. Baffles should be made of durable material securely fastened. Baffles should be in place at the time of framing inspection.

Three blown insulations that provide R-19 are:

Material	Minimum Thickness	Maximum Net Coverage/Bag	Bags/1000 Sq. Ft.
Cellulose	5½"	59 sq. ft. (40 lb. bag)	17
Glass fiber	3¾"	51 sq. ft. (24 lb. bag)	20
Rock wool	6½"	26 sq. ft. (27 lb. bag)	38

Bag Label Example: The manufacturer recommends these maximum coverages at these minimum thicknesses to provide the levels of installed insulation resistance (R) values shown:

(Based on 25-pound nominal weight bag)

R-Value	Minimum Thickness	Minimum Weight per Sq. Ft.	Bags per 1000 Sq. Ft.	Maximum Net Coverage per Bag
To obtain an insulation resistance R of:	Installed insulation should not be less than:	The weight per sq. ft. of installed insulation should be not less than:	Number of bags per 1000 sq. ft. of net area should not be less than:	Contents of this bag should not cover more than:
R-30	13¾ in. thick	0.768 lbs. per sq. ft.	30	33 sq. ft.
R-22	10 in. thick	0.558 lbs. per sq. ft.	22	45 sq. ft.
R-19	8¾ in. thick	0.489 lbs. per sq. ft.	20	51 sq. ft.
R-11	5 in. thick	0.279 lbs. per sq. ft.	11	90 sq. ft.

Weight contents: not less than 24 lbs.

R-values are determined in accordance with ASTM C-687 and C-236

Fig. 12

REFLECTIVE INSULATION

Reflective insulation is composed of aluminum foil in one or more layers either plain or laminated to one or both sides of kraft paper for structural strength. The insulation value for reflective air spaces, which this type of insulation provides, varies widely depending on the direction of heat flow. They are much more efficient when the heat flow is *down*. Reflective insulations which comply with the requirements when used in a floor, may not be satisfactory in ceilings or walls, where the heat flow is

upward and horizontal, respectively. Reflective insulations are effective in controlling radiant heat energy when installed so that they face an air space. Insulation should be installed in such a manner that it is continuous, without holes or tears.

SPRAYED INSULATION

There are several types of insulation which are sprayed against the surface of the building materials or in cavities. Some of these are cellulose with binder, mineral wool with binder, and cellular foams. They may be sprayed directly on concrete, masonry, wood, plastic, or metal panels or may be sprayed between the framing members. Manufacturer's recommended instructions should be followed. To determine that the proper thickness is installed, either refer to the plans and specifications, or request a certification from the supplier that the insulation installed provides the required "R" value.

TYPICAL INSULATION THICKNESSES AND VALUES

Insulation	Approximate R-Value	Thickness
Fiber glass	11	3½"
Fiber glass	13	3¾"
Fiber glass	19	6"
Fiber glass	30	8"
Fiber glass	38	12"
Extruded Polystyrene Foam	5.4	1"
Extruded Polystyrene Foam	10.8	2"

VAPOR BARRIERS

Vapor barriers are used in conjunction with insulation to decrease the chance of moisture condensation inside the building insulation. Vapor barriers are placed on the side of the wall, ceiling or floor that is warm in winter. For equal vapor pressures, moisture vapor penetration through holes or tears in the insulation vapor barrier is proportional to the size of the opening. Holes or tears should be repaired. A snug fit of blanket flanges against the framing is necessary to prevent moisture from bypassing the vapor barrier.

EQUIPMENT

The installation of the heating system can contribute to inefficiencies. A furnace which is oversized by a factor of 2 will require 8 to 10% more fuel than a furnace of correct size. An installation that has uninsulated ducts passing through an unheated crawl or attic space will lose about 1.5 Btu per hour per square foot of duct per degree of temperature differential between duct air and outside air. This can amount to 40% of a furnace output under mild conditions. Undersized ducting will reduce the amount of circulating air and will affect the capacity of the furnace, but will normally have little effect upon its efficiency. Atmospheric combustion equipment that draws its combustion and stack-dilution air from the heated space will require up to 8% more fuel in a season to heat the required makeup air than sealed combustion equipment. Stack heat recovery devices can recover from about 4% at 450° F to 8% at 800° F.

The appliance manufacturer should be consulted when retrofitting the appliance with combustion air to assure that the appliance warranty is not affected.

Effect of Sizing Limitation on Equipment

Using the example on system design illustrated in Appendix A, an analysis was made to see what impact or problem the proposal for limiting the size of equipment to 15% above the design losses would have.

Example:

Total construction loss	27,760 Btu/hour
One air change per hour:	
Inside volume = 12,188 cu. ft.	
$Q = (12,188) (90) (.018) = 19,744$ Btu/hour	
Total infiltration loss	<u>19,744 Btu/hour</u>
	47,504 Btu/hour

Maximum furnace size:

$$47,504 \text{ Btu/hour} + 47,504 (.15) \text{ Btu/hour} = 54,630 \text{ Btu/hour}$$

COMBUSTION AIR FOR FIREPLACES

It is recommended that combustion air from the exterior be provided for all fireplaces. Masonry fireplaces can be made more energy efficient with combustion air terminating in the fireplace. The opening of the fireplace should be equipped with a door and the combustion air duct with a damper and a louver to minimize air leakage during periods of nonuse.

CONDENSATION CONTROL

Air Infiltration

The department will accept infiltration losses determined by the air crack method or an overall value of $\frac{1}{2}$ air change per hour.

The department will accept the use of engineered top-side moisture vent systems.

Relative Humidity

Winter: During the winter it is desirable to have humidity in the air in order to prevent the nostrils from becoming dry, furniture from cracking, etc. However, from an energy standpoint, it is desirable to keep the relative humidity low; the trade-off is at about 30%.

Summer: During the summer it is desirable to reduce the level of relative humidity in the building in relationship to the outside relative humidity. The relative humidity should be kept as high as possible in order to conserve energy, but low enough for comfort. The relative humidity should be kept above 55%, but less than 60%.