

CR 85-187

RULES CERTIFICATE

STATE OF WISCONSIN)
) SS
DEPT. OF INDUSTRY,)
LABOR & HUMAN RELATIONS)

RECEIVED

MAR 3 1988
4:00 pm
Revisor of Statutes
Bureau

TO ALL TO WHOM THESE PRESENTS SHALL COME, GREETINGS:

I, John T. Coughlin, Secretary of the Department of Industry, Labor and Human Relations, and custodian of the official records of said department, do hereby certify that the annexed rule(s) relating to Plumbing Code were duly approved and adopted by this department on March 2, 1988.
(Subject) (Date)

I further certify that said copy has been compared by me with the original on file in this department and that the same is a true copy thereof, and of the whole of such original.

IN TESTIMONY WHEREOF, I have hereunto set my hand and affixed the official seal of the department at 8:00 a.m. in the city of Madison, this 2nd day of March A.D. 19 88.

John T. Coughlin
Secretary

6-1-88

ORDER OF ADOPTION

Pursuant to authority vested in the Department of Industry, Labor and Human Relations by section(s) 101.02 (1), 145.02 (2) and 145.25 (2), Stats., the Department of Industry, Labor and Human Relations creates; amends; repeals and recreates; repeals and adopts rules of Wisconsin Administrative Code chapter (s):

ILHR 84 and Ind 69
(Number)

Plumbing Code
(Title)

The attached rules shall take effect on first day of the month following publication in the Wisconsin Administrative Register pursuant to section 227.22, Stats.

Adopted at Madison, Wisconsin, this

date: March 2, 1988

DEPARTMENT OF INDUSTRY, LABOR AND HUMAN
RELATIONS

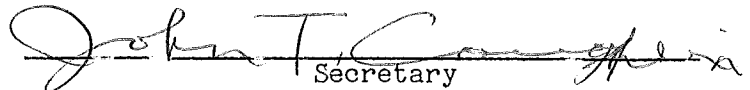
Secretary



RULES in FINAL DRAFT FORM

Rule: Chapters ILHR 84 and S. Ind 69.23

Relating to: State Uniform Plumbing Code

Clearinghouse Rule No.: 85-187

AN ORDER to repeal and recreate ILHR 84.01 to 84.60 and A-84.20 (3); and to create ILHR 82.11 (55m) and (181), A-Tables 84.30-8 and -9, A-84.40, and Ind 69.23 (5), relating to the state uniform plumbing code and fees.

ANALYSIS OF RULES

Pursuant to s. 145.02, Stats., the Department of Industry, Labor and Human Relations is responsible for the supervision of plumbing in order to safeguard the public's health. This responsibility has been delegated to the Bureau of Plumbing within the Division of Safety and Buildings which administers and enforces the State Uniform Plumbing Code, chapters ILHR 81 to 86.

Chapter ILHR 84 of the State Uniform Plumbing Code establishes minimum standards which govern the quality and installation of materials, fixtures, appliances, appurtenances and equipment to be use in plumbing. In order for the plumbing code to be effective and reasonable, the standards must be updated periodically to reflect the changing technologies and practices and new materials. The proposed rules intend to repeal and recreate the entire chapter. The revisions to chapter ILHR 84:

ILHR 84.10; Reflect the reorganization of the plumbing product approval program and voluntary listing program. Under the program, only products in the following categories will be required to obtain department approval before being sold or used as plumbing:

- chemical or biochemical treatments for private sewage systems;
- cross-connection control devices;
- health care plumbing appliances;
- laboratory plumbing appliances;
- prefabricated holding tanks and septic tanks;
- prefabricated plumbing;
- water conserving faucets and fixtures;
- water treatment devices;

Other plumbing products could be voluntarily listed with the department.

ILHR 84.11; Require the identification of plumbing products only if the applicable reference standard requires identification.

- ILHR 84.20; (a) Require kitchen sink faucets in dwelling and living units to be water conserving.

(b) Clarify that only the hangers for wall mounted water closets must conform to ANSI A112.6.1M.

(c) Clarify that the national standards referenced for plumbing fixtures relate to specific material types.

(d) Include requirements for water heaters and safety devices.

- ILHR 84.30; (a) Include tables listing acceptable materials which may be used for effluent distribution piping for private sewage systems.

(b) Create a table listing acceptable materials which may be used for exterior turf sprinkler systems.

(c) Include plastic pipe and tube as acceptable materials for water distribution systems.

- ILHR 84.50; Clarify the uses of and differences between alternate and experimental product approvals.

Chapter Ind 69 establishes fees for offsetting the costs incurred by the department for its services. The revisions to this chapter implement fees for the plumbing product approval program and voluntary listing program.

The proposed rules were developed from department prepared working drafts which included concepts of several nationally recognized model plumbing codes. The drafts were reviewed and refined with input of a citizens advisory committee. Members of that review group were:

Jim Sargent, Director, Bureau of Plumbing, Department of Industry, Labor and Human Relations

William Reigel, Master Plumbers

F. R. Badeau, Wisconsin Plumbing Contractors Association

James Barrett, City of Milwaukee, Building Inspections, Plumbing Bureau

Paul Gobster, Wisconsin Society of Professional Engineers

Gary Hamilton, Wisconsin Pipe Trades Association

Tom Nelson, Wisconsin Plumbing Contractors Association

Alex Neuwirth, Wisconsin Pipe Trades Association

Eugene Shumann, Plumbing Designer

* * * * *

Pursuant to the authority vested in the state of Wisconsin, Department of Industry, Labor and Human Relations by ss. 101.02 (1), 145.02 (2) and 145.25 (2), Stats., the department hereby repeals and recreates and creates rules interpreting ss. 145.02 (1), (3), and (5) and 145.13, as follows:

SECTION 1. ILHR 82.11 (55m) is created to read:

ILHR 82.11 (55m) "Cross-connection control device" means any mechanical device which automatically prevents backflow in a water supply system.

SECTION 2. ILHR 82.11 (181) is created to read:

ILHR 82.11 (181) "Water treatment device" means a device which:

(a) Renders inactive or removes microbiological, particulate, inorganic, organic or radioactive contaminants from water which passes through the device or the water supply system downstream of the device; or

(b) Injects into the water supply system gaseous, liquid or solid additives other than water, to render inactive microbiological, particulate, inorganic, organic or radioactive contaminants.

SECTION 3. Chapter ILHR 84 is repealed and recreated to read:

Chapter ILHR 84
PLUMBING PRODUCTS

ILHR 84.01 SCOPE. The provisions of this chapter govern the quality and installation of materials, fixtures, appliances, appurtenances, and equipment relating to plumbing.

ILHR 84.02 PENALTIES. Penalties for violations of this chapter shall be assessed in accordance with ss. 145.12 and 145.25, Stats.

ILHR 84.03 DEFINITIONS. In this chapter:

(1) "Health care plumbing appliance" means a plumbing appliance, the function of which is unique to health care activities.

(2) "Laboratory plumbing appliance" means a plumbing appliance, the function of which is unique to scientific experimentation or research activities.

(3) "Prefabricated plumbing" means concealed drain piping, vent piping or water supply piping or a combination of these types of piping, contained in a modular building component, which will not be visible for inspection when delivered to the final site of installation.

ILHR 84.10 DEPARTMENT APPROVAL. No fixture, appliance, appurtenance, material, device or product may be sold for use in a plumbing system or may be installed in a plumbing system, unless it is of a type conforming to the standards or specifications of chs. ILHR 82 and 83 and this chapter and ch. 145, Stats.

(1) If it is alleged that the approval of a fixture, appliance, appurtenance, material, device or product under this section would result in an adverse health effect or potentially adverse health effect on the waters of the state, the department may require an alternate or experimental product approval under s. ILHR 84.50.

(2) PRODUCT REVIEW AND APPROVAL. Each type of plumbing product which falls into one of the categories specified in Table 84.10 shall be approved by the department in accordance with this subsection before the product may be sold for use in a plumbing system or installed in a plumbing system. —

(a) Except as provided in subds. 1 and 2, specifications and plans or drawings for each type of product shall be submitted to the department for review. The submittal shall be accompanied by sufficient data and information to determine if the product and its performance complies with the provisions of chs. ILHR 82, 83 and this chapter and ch. 145, Stats.

1. The submitter of a cross-connection control device listed under Table 84.10, line 2 may submit in lieu of specifications, plans or drawings evidence that the product is currently listed by a nationally recognized evaluation agency acceptable to the department. Evidence substantiating the listing by an evaluation agency shall include a research report from which it can be determined that the product conforms to the appropriate requirements of s. ILHR 84.30 (5) (c).

2. The submitter of a water-conserving type of product listed under Table 84.10, line 7 may submit in lieu of specifications, plans or drawings evidence that the product is currently listed by a nationally recognized evaluation agency acceptable to the department. Evidence substantiating the listing by an evaluation agency shall include a research report from which it can be determined that the product conforms to the requirements of s. ILHR 84.20.

(b) The department may require that a submitter of a product for review have the product tested and its performance certified by an approved testing laboratory.

(c) If, upon review, the department determines that a product conforms to the provisions of chs. ILHR 82, 83 and this chapter and ch. 145, Stats., the department shall issue an approval in writing. The department may impose specific conditions in granting an approval. Violations of the conditions under which an approval is granted shall constitute a violation of this chapter.

(d) If, upon review, the department determines that a product does not conform to provisions of chs. ILHR 82, 83 and this chapter and ch. 145, Stats., the request for approval shall be denied in writing.

(e) The department shall review and make a determination on an application for a product approval within 40 business days of receipt of all fees, plans, drawings, specifications and other information required to complete the review.

(f) If an approved plumbing product is modified or additional assertions of function or performance are made, the approval shall be considered null and void, unless the change is submitted to the department for review and the approval is reaffirmed.

(g) Approvals for plumbing products issued by the department prior to November 1, 1985, shall expire 30 months after the effective date of this section.

(h) Approvals for plumbing products issued by the department after November 1, 1985, shall expire at the end of the 60th month after the date of approval issuance.

TABLE 84.10
SUBMITTALS TO DEPARTMENT

Product Categories

1. Chemical or biochemical treatments for private sewage systems
 2. Cross-connection control devices
 3. Health care plumbing appliances
 4. Laboratory plumbing appliances
 5. Prefabricated septic/holding tanks
 6. Prefabricated plumbing
 7. Water-conserving faucets, spouts and plumbing fixtures:
 - a. Kitchen sink faucets for use in dwelling units and living units.
 - b. Lavatory faucets
 - c. Shower heads
 - d. Urinals
 - e. Urinal flushing devices
 - f. Water closets
 - g. Water closet flushing devices
 8. Water treatment devices
-

*See s. 145.25, Stats., and s. ILHR 84.20 (3) concerning water conserving fixtures.

(3) **PRODUCT LISTING.** The department may list, upon request, plumbing products which conform to the standards or specifications referenced in ch. ILHR 82, 83 or this chapter, but which do not require approval under sub. (2). Each request for listing shall be made on a form provided by the department.

Note: Request for product listing is to be made on form SBD 7557 which may be obtained from Safety and Buildings Division, P.O. Box 7969, Madison, Wisconsin 53707.

(4) **REVOCAION.** The department may revoke any approval or listing issued under this section for any false statements or misrepresentation of facts or data on which the approval or listing was based, or as a result of the product's failure, or if future information indicates a potential health hazard or potential threat to the waters of the state.

(5) **LIMITATIONS.** An approval or listing of a plumbing product by the department may not be construed as an assumption of any responsibility for defects in design, construction or performance of any product nor for any damages that may result.

(6) **FEES.** Fees for product approval review and product listing shall be submitted in accordance with s. Ind 69.23.

Note: See Appendix for further explanatory material.

ILHR 84.11 IDENTIFICATION. Each length of pipe and each pipe fitting, trap, fixture, material, device and product to be used in plumbing shall be marked as required by the applicable standard specified by reference in this chapter or as specified in s. ILHR 83.15 for septic tanks and holding tanks, and s. ILHR 84.20 (5) (o) for water treatment devices.

ILHR 84.12 PENETRATIONS OF FIRE-RESISTIVE ASSEMBLIES. Penetrations of fire-resistive assemblies, such as walls and floor-ceiling systems, by plumbing systems or plumbing materials shall be protected in accordance with requirements of chs. ILHR 50 to 64.

Note: See Appendix for further explanatory material.

ILHR 84.13 CHEMICAL OR BIOCHEMICAL TREATMENTS FOR PRIVATE SEWAGE SYSTEMS.

Chemical or biochemical treatments for private sewage systems shall function and perform in accordance with the assertions submitted to the department. Chemical or biochemical treatments for private sewage systems may not directly or indirectly adversely affect bacterial action in the systems, soil hydraulic conductivity in the absorption areas, or groundwater quality beneath the systems.

ILHR 84.14 HEALTH CARE AND LABORATORY PLUMBING APPLIANCES. Health care plumbing appliances and laboratory plumbing appliances shall function and perform in accordance with the drain, vent, water supply and backflow protection requirements of ch. ILHR 82.

ILHR 84.20 PLUMBING FIXTURES, APPLIANCES AND EQUIPMENT. (1) DESIGN AND CONSTRUCTION. All plumbing fixtures, appliances and equipment shall be designed and constructed to:

- (a) Ensure durability, proper service and sanitation;
- (b) Be free from defects;
- (c) Be free from concealed fouling surfaces;
- (d) Not require undue efforts in cleaning and operating; and
- (e) Prevent nonpotable liquids, solids or gasses from being introduced into a potable water supply system through cross-connections.

(2) MATERIALS. Plumbing fixtures shall have smooth surfaces which are impervious to water.

(3) WATER CONSERVING FAUCETS, SPOUTS AND PLUMBING FIXTURES. Water conserving faucets, spouts and plumbing fixtures which meet or exceed the water conservation requirements established in par. (b) shall be installed as specified in par. (a).

(a) 1. All lavatory faucets, shower heads, urinals, urinal flushing devices, water closets and water closet flushing devices shall conform to par. (b).

2. All faucets installed on kitchen sinks of dwelling units and living units shall conform to par. (b) 4.

3. All lavatory faucets installed in public restrooms shall be of a self-closing type.

(b) 1. 'General'. Flow control or flow restricting devices shall be installed on the water inlet side or shall be an integral part of the faucet, spout or fixture. A flow controlling or restricting aerator shall be considered to be an integral part of a faucet or spout.

2. 'Lavatory faucet'. a. The maximum discharge rate of lavatory faucets shall be 3 U.S. gallons per minute at an 80 psig flowing supply pressure.

b. Lavatory faucets which are of the self-closing type shall allow a maximum of one U.S. gallon to flow through the faucet after the handle or actuator is released.

3. 'Shower heads'. The maximum discharge rate of shower heads shall be 3 U.S. gallons per minute at an 80 psig flowing supply pressure.

4. 'Sink faucets'. The maximum discharge rate of sink faucets shall be 3 U.S. gallons per minute at an 80 psig flowing supply pressure.

5. 'Urinals'. Urinals shall function properly with a maximum of 1.5 U.S. gallons per flush per fixture use at static test pressures of 20 psig and 80 psig.

6. 'Urinal flushing devices'. The flushing cycle for urinal flushing devices shall discharge a maximum of 1.5 U.S. gallons per flush per fixture use at static test pressures of 20 psig and 80 psig.

7. 'Water closets'. Water closets shall function properly with a maximum of 4 U.S. gallons per flush over the range of static test pressures specified in Table 84.20.

8. 'Water closet flushing devices'. The flushing cycle for water closet flushing devices shall discharge a maximum of 4 U.S. gallons over the range of static test pressures specified in Table 84.20.

TABLE 84.20
STATIC TEST PRESSURES
FOR WATER CLOSETS AND WATER CLOSET FLUSHING DEVICES

Tank Type	Flushometer Type	
	Siphonic	Blow Out
20 to 80 psig	25 to 80 psig	35 to 80 psig

(4) GENERAL REQUIREMENTS. (a) Fixture outlets. 1. The outlet passageway of a fixture shall be free from impairments and of sufficient size to insure proper discharge of the fixture contents under normal conditions.

2. The outlet connection of a fixture which directly connects to the drain system shall be an air and watertight joint.

(b) Installation of fixtures. 1. 'Access for cleaning'. Plumbing fixtures shall be so installed as to afford easy access for cleaning both the fixture and the area around it.

2. 'Securing wall mounted fixtures'. Wall mounted fixtures shall be rigidly supported by a hanger which is attached to structural members so that the load is not transmitted to the fixture drain connection or any other part of the plumbing system. The hanger for a wall mounted water closet shall conform to ANSI A112.6.1M.

3. 'Water supply protection'. The water supply pipes and fittings within every plumbing fixture shall be so installed as to prevent backflow.

4. 'Design of overflow'. A fixture which is provided with an overflow outlet shall be designed and installed so that standing water in the fixture cannot rise in the overflow when the fixture's stopper is closed, and so that no water remains in the overflow when the fixture is empty.

5. 'Connection of overflows'. The overflow from any fixture shall discharge into the drain system on the inlet or fixture side of the trap.

6. 'Overflows in flush tanks'. Flush tanks shall be provided with overflows discharging to the fixture served and shall be of sufficient size to prevent flooding the tank at the maximum rate at which the tanks are supplied with water.

7. 'Strainers'. All plumbing fixtures other than water closets, clinic sinks, trap standard service sinks with flush rims, urinals, standpipes and waste sinks shall be provided with strainers, cross bars or pop-up stoppers which restrict the clear opening of the waste outlet.

8. 'Flushometer valves'. Flushometer valves shall be equipped with vacuum breakers which conform to ASSE 1001. Flushometer valves may not be used where the water pressure is insufficient to properly operate them. When the valve is operated, it shall complete the cycle of operation automatically, opening fully and closing positively under the water supply pressure. Each flushometer shall be provided with a means for regulating the flow through it.

9. 'Safing'. The floors of all shower stalls, shower rooms, floor setting service sinks or receptors, sunken bathtubs or other similar fixtures shall be protected with a safing material installed beneath the finish floor of the entire fixture or room and upward along the sides to a minimum of 6 inches above the curb or maximum water level of the fixture. Safing materials shall conform to s. ILHR 84.30 (6). The corners of the fixture or room shall be safed to a height of 6 feet and at least 3 inches in each direction from the corners. The safing material shall be properly drained. Prefabricated fixtures and installations directly over an unexcavated portion of a building are exempt from safing requirements.

Note: Chapters ILHR 50 to 64 contain provisions for toilet rooms and sanitary facilities, for public buildings and places of employment concerning toilet facilities for the handicapped, fixture compartments, number of fixtures for the different types of occupancies and toilet room finishes.

Note: See Appendix for further explanatory material.

(5) PLUMBING FIXTURES AND PLUMBING APPLIANCES. (a) Automatic clothes washers. Residential type automatic clothes washers shall conform to ASSE 1007.

(b) Bathtubs. 1. a. Enameled cast iron bathtubs shall conform to ANSI A112.19.1M.

b. Porcelain enameled formed steel bathtubs shall conform to ANSI A112.19.4.

c. Plastic bathtubs shall conform to ANSI Z124.1.

2. Bathtubs shall have waste outlets and overflows at least 1-1/2 inches in diameter. A pop-up stopper or other closing device shall be provided on the waste outlet.

3. All whirlpool piping for bathtubs shall drain by gravity to the trap serving the bathtub.

4. All waterways of the whirlpool pump for a bathtub shall drain by gravity to the trap serving the bathtub.

(c) Bidets. Vitreous china bidets shall conform to the material requirements in ANSI A112.19.2M.

1. A bidet may not be located closer than 15 inches from its center to any side wall, partition, vanity or other obstruction, nor closer than 30 inches center to center from a water closet.

2. Bidets with submerged inlet fittings shall be protected by vacuum breakers which conform to ASSE 1001.

(d) Dishwashing machines. 1. Residential type dishwashing machines shall conform to ASSE 1006.

2. Commercial type dishwashing machines shall conform to ASSE 1004.

(e) Drinking fountains. 1. Drinking fountains and water coolers shall conform to ARI 1010 or ANSI A112.19.2M.

2. Drinking fountains may not be installed in toilet rooms.

3. The water supply for drinking fountains shall be provided with an adjustable valve fitted with a loose key or an automatic self-closing valve permitting regulation of the rate of flow of water. The water supply issuing from the nozzle shall be of sufficient volume and height so that persons using the fountain need not come in direct contact with the nozzle or orifice.

4. A drinking fountain may not have a waste outlet less than 1-1/4 inches in diameter.

(f) Floor drains. 1. Floor drains shall be provided with removable strainers of sufficient strength to carry the anticipated loads.

2. The floor drain shall be so constructed that it can be cleaned, and the drain inlet shall be accessible at all times.

3. Floor drains shall be of a size to efficiently serve the intended purpose. The floor drain outlet shall not be less than 2 inches in diameter.

(g) Food waste grinders. 1. Residential type food waste grinders shall conform to ASSE 1008. Commercial type food waste grinders shall conform to ASSE 1009.

2. Food waste grinders shall be connected to a drain of sufficient size to serve the unit, but not less than 1-1/2 inches in diameter.

3. Food waste grinders shall be connected to a drain and trapped separately from any other fixtures or sink compartments.

4. All food waste grinders shall be provided with an adequate supply of cold water at a sufficient flow rate to insure proper functioning of the unit.

(h) Laundry trays. Each compartment of a laundry tray shall be provided with a waste outlet not less than 1-1/2 inches in diameter.

(i) Lavatories. 1. a. Enameled cast iron lavatories shall conform to ANSI A112.19.1M.

b. Vitreous china lavatories shall conform to ANSI A112.19.2M.

c. Stainless steel lavatories shall conform to ANSI A112.19.3.

d. Porcelain enameled formed steel lavatories shall conform to ANSI A112.19.4.

e. Plastic lavatories shall conform to ANSI Z124.3.

2. Cultured marble vanity tops with an integral lavatory shall conform to ANSI Z124.3.

3. Lavatories shall have waste outlets not less than 1-1/4 inches in diameter.

(j) Showers. 1. Prefabricated plastic showers and shower compartments shall conform to ANSI Z124.2.

2. Water distribution piping from the shower valve to the shower head outlet shall be securely attached to the structure.

3. Except for combination bathtub-shower units, waste outlets serving showers shall be at least 2 inches in diameter and shall have removable strainers of sufficient strength for the anticipated loads.

4. Where a waste outlet serves more than one shower space or shower head, the waste outlet shall be at least 2 inches in diameter and the waste outlet shall be so located and the floor so pitched that waste water from one shower does not flow over the floor area serving another shower.

5. All shower compartments, regardless of shape, shall have a minimum finished interior of 900 square inches and shall be capable of encompassing a circle with a diameter of 30 inches. The minimum required area and dimension shall be measured in a horizontal plane 24 inches above the top of the threshold and may not extend beyond the centerline of the threshold. The minimum area and dimensions shall be maintained to a point 70 inches above the shower waste outlet with no protrusions other than the fixture valve or valves, showerheads, soap dishes and safety grab bars or rails.

Note: See Appendix for further explanatory materials.

(k) Sinks. 1. a. Enameled cast iron sinks shall conform to ANSI A112.19.1M.

b. Vitreous china sinks shall conform to ANSI A112.19.2M.

c. Stainless steel sinks shall conform to ANSI A112.19.3.

d. Porcelain enameled formed steel sinks shall conform to ANSI A112.19.4.

2. Sinks shall be provided with waste outlets not less than 1-1/2 inches in diameter. Sinks on which a food grinder is installed shall have a waste opening not less than 3-1/4 inches in diameter.

(l) Urinals. 1. Vitreous china urinals shall conform to ANSI A112.19.2M.

2. A urinal may not be located closer than 16 inches from its center to any side wall, partition, vanity or other obstruction, nor closer than 30 inches center to center, between urinals. When the space between stall type urinals or a stall type urinal and a side wall is less than 12 inches, the space shall be filled flush with the front and top of the urinal with nonabsorbent material.

Note: See Appendix for further explanatory material.

3. Stall type urinals shall be set into the floor and the floor shall be pitched toward the fixture.

4. Automatic siphon urinal flush tanks may not be installed.

(m) Water closets. 1. a. Vitreous china water closets shall conform to ANSI A112.19.2M.

b. Plastic water closets shall conform to ANSI Z124.4.

2. Water closets in public buildings and places of employment shall have elongated bowls and hinged, open front seats without covers.

3. Water closets in individual living units, day care centers, individual executive offices, and sleeping units of hotels and motels may be of the round bowl type, provided with hinged, closed front seat, with or without a cover.

4. In nurseries, schools and other similar places where plumbing fixtures are provided for the use of children under six years of age, water closets may be of a size and height suitable for the children's use.

5. All water closet seats shall be of smooth nonabsorbent material.

6. Each water closet shall be individually equipped with a flushing device. All flushing devices shall be readily accessible for maintenance and repair. Ballcocks and fill valves shall be of the anti-siphon type and shall conform to ASSE 1002. The critical level mark on the ballcock and fill valve shall be located at least one inch above the full opening of the overflow pipe.

7. A water closet may not be located closer than 15 inches from its center to any side wall, partition, vanity, or other obstruction, nor closer than 30 inches center to center, between water closets. There shall be at least 24 inches clearance in front of a water closet to any wall, fixture or door.

Note: See Appendix for further explanatory material.

8. No person may install or maintain pan, plunger, offset washout, washout, long hopper, frostproof and other types of water closets having invisible seals or unventilated spaces or walls not thoroughly cleansed at each flushing.

(n) Water heaters. 1. 'Listed equipment'. All water heaters shall bear the label of a listing agency approved by the department. Listing agencies approved by the department shall include:

- a. Underwriters Laboratories, Inc.;
- b. American Gas Association; and
- c. American Society of Mechanical Engineers.

2. 'Design'. a. All pressurized water heaters and pressurized hot water storage tanks, except those bearing the label of the American Society of Mechanical Engineers, shall be designed and constructed to withstand a minimum test pressure of 150% of the maximum allowable working pressure of the heater or tank.

b. All pressurized water heaters and pressurized hot water storage tanks shall be rated for a minimum working pressure of 125 psig.

c. A drain valve shall be installed at the lowest point of each water heater and hot water storage tank. Drain valves shall conform to ASSE 1005.

3. 'Safety devices'. a. Relief valves shall be listed by the American Gas Association, Underwriters Laboratories, Inc. or American Society of Mechanical Engineers when the heat input to a water heater is less than or equal to 200,000 Btu per hour.

b. Relief valves shall be listed by the American Society of Mechanical Engineers when the heat input to a water heater exceeds 200,000 Btu per hour.

c. Pressure relief valves shall be set to open at either the maximum allowable working pressure rating of the water heater or storage tank or 150 psig, whichever is smaller.

d. Temperature and pressure relief valves shall be set to open at a maximum of 210°F and in accordance with subpar. c.

4. 'Hot water dispensers'. Nonpressurized point-of-use water heaters shall conform to ASSE 1023.

(o) Water treatment devices. 1. Water softeners shall conform to WQA S-100.

2. a. Except as provided in subpar. b., water treatment devices shall function and perform in accordance with the assertions submitted to the department under s. ILHR 84.10, relating to rendering inactive or removing contaminants.

b. A water treatment device which injects a water treatment compound into a water supply system shall maintain the compound concentration in the system over the working flow rate range and pressure range of the device.

3. Except as specified in subd. 4., water treatment compounds introduced into the water supply system by a water treatment device shall be listed as an acceptable drinking water additive by a listing agency approved by the department. Listing agencies approved by the department shall include:

- a. United States Environmental Protection Agency;
- b. United States Food and Drug Administration; and
- c. National Sanitation Foundation.

4. A water supply system shall be protected from backflow when unlisted water treatment compounds, which may affect the potability of the water, are introduced into the system. The department shall determine the method of backflow protection. Water supply outlets for human use or consumption may not be installed downstream of the introduction of an unlisted water treatment compound.

5. Water treatment devices designed for contaminated water supplies shall be labeled to identify the following information:

- a. The name of the manufacturer of the device;
- b. The device's trade name; and
- c. The device's model number.

(p) Other plumbing fixtures, appliances and equipment. Plumbing fixtures, appliances and equipment not specifically covered in this subsection shall conform to the applicable performance standards of this chapter and chs. ILHR 82 and 83.

(6) FAUCETS, SPOUTS AND FIXTURE SUPPLY CONNECTORS. (a) Except for circular and semi-circular wash fountains, all faucets and showerheads shall conform to ANSI A112.18.1M.

(b) Circular and semi-circular wash fountains shall conform to the working pressure, burst pressure, discharge rate and product marking requirements of ANSI A112.18.1M.

(c) All fixture supply connectors shall be designed and constructed to withstand a minimum pressure of 100 psig at 180°F.

(d) Flexible hose and spray assemblies for residential sinks shall conform to ASSE 1025.

(e) Hand held showers shall conform to ASSE 1014.

ILHR 84.30 PLUMBING MATERIALS. (1) GENERAL. When selecting the material and size for a plumbing system, due consideration shall be given to the soil, liquid, and atmospheric environments that will eventually surround the plumbing system.

- (a) The bending or offsetting of flexible or annealed pipe or tubing shall be in accordance with the applicable material standard or the instructions of the manufacturer of the pipe or tubing.
- (b) Pipe or tubing with gouges, cuts or deep scratches may not be installed.
- (c) Pipe or tubing which has been kinked may not be installed.
- (d) The bending or offsetting of rigid pipe shall be prohibited.
- (e) Nailing plates shall be installed to protect copper or plastic pipe or tubing from puncture.

Note: See s. ILHR 84.30 (4) (f) concerning the bending of polybutylene water distribution pipe and tubing.

(2) SANITARY DRAIN AND VENT SYSTEMS. Sanitary drain systems and vent systems shall be of such material and workmanship as set forth in this subsection.

- (a) Above ground drain and vent pipe. Except as provided in s. ILHR 82.33 (2), drain pipe and vent pipe installed above ground shall conform to one of the standards listed in Table 84.30-1.

(b) Underground drain and vent pipe. Except as provided in par. (d), drain pipe and vent pipe installed underground shall conform to one of the standards listed in Table 84.30-2.

(c) Sanitary building sewer pipe. Except as provided in s. ILHR 83.15 (4) (e), sanitary building sewer pipe shall conform to one of the standards listed in Table 84.30-3.

(d) Effluent piping. 1. Except as provided in s. ILHR 83.15 (4) (e), non-perforated drain piping conveying effluent from a septic tank to the distribution piping of a nonpressurized soil absorption system shall conform to one of the standards listed in Table 84.30-3.

2. Perforated drain piping distributing septic tank effluent in a nonpressurized soil absorption system shall conform to one of the standards listed in Table 84.30-4.

3. Except as provided in s. ILHR 83.15 (4) (e), nonperforated drain piping conveying effluent from a septic tank to the distribution piping of a pressurized soil absorption system shall conform to one of the standards listed in Table 84.30-5 or as otherwise approved by the department.

4. Drain piping distributing septic tank effluent in a pressurized soil absorption system shall conform to one of the standards listed in Table 84.30-5 and shall be perforated in accordance with s. ILHR 83.14 (3) (c).

(e) Chemical drain and vent pipe. Drain systems and vent systems for chemical wastes shall be of approved corrosion resistant material. The manufacturer of the pipe shall indicate to the department the material's suitability for the concentrations of chemicals involved.

(f) Catch basins, interceptors and sumps. Catch basins, interceptors and sumps shall be constructed in a watertight manner of precast reinforced concrete, reinforced monolithic concrete, cast iron, coated 12-gauge steel, vitrified clay, fiberglass, plastic or other approved materials.

(g) Manholes. Manholes shall be constructed in a watertight manner of precast reinforced concrete, reinforced monolithic concrete, brick or block, fiberglass or other approved materials. Fiberglass manholes may be approved for use in traffic areas if the top section of the manhole is not made of fiberglass.

TABLE 84.30-1
ABOVE GROUND DRAIN AND VENT PIPE AND TUBING

Material	Standard
Acrylonitrile butadiene styrene (ABS)	ASTM D1527; ASTM D2661; ASTM F628
Brass	ASTM B43
Cast iron	ASTM A74; CISPI 301
Copper	ASTM B42; ASTM B88; ASTM B306
Galvanized steel	ASTM A53; ASTM A120
Lead	FS-WW-P-325B
Polyvinyl chloride (PVC)	ASTM D2665; ASTM D1785
Synthetic rubber hose ^a	AHAM DW-1

Note a: The installation of synthetic rubber hose is limited in use to indirect waste piping or local waste piping from dishwashers in accordance with s. ILHR 82.33 (9) (d).

TABLE 84.30-2
UNDERGROUND DRAIN AND VENT PIPE AND TUBING

Material	Standard
Acrylonitrile butadiene styrene (ABS)	ASTM D1527; ASTM D2661; ASTM F628
Cast iron	ASTM A74; CISPI 301
Concrete	ASTM C14; ASTM C76
Copper ^a	ASTM B42; ASTM B88
Polyvinyl chloride (PVC)	ASTM D2665; ASTM D1785
Vitrified clay	ASTM C700

Note a: Copper tubing, type M, may not be installed underground.

TABLE 84.30-3
SANITARY BUILDING SEWER PIPE AND TUBING

Material	Standard
Acrylonitrile butadiene styrene (ABS) ^a	ASTM D1527; ASTM D2661; ASTM D2751; ASTM F628
Acrylonitrile butadiene styrene (ABS) composite	ASTM D2680
Cast iron	ASTM A74; CISPI 301
Concrete	ASTM C14; ASTM C76
Copper ^b	ASTM B42; ASTM B88
Polyvinyl chloride (PVC) ^a	ASTM D2665; ASTM D3033; ASTM D3034 ASTM D1785
Vitrified clay	ASTM C700

Note a: Thermoplastic sewer pipe shall be installed in accordance with ASTM D2321.

Note b: Copper tubing, type M, may not be installed underground.

TABLE 84.30-4
PERFORATED EFFLUENT DISTRIBUTION PIPING FOR
NONPRESSURIZED SOIL ABSORPTION SYSTEMS

Material	Standard
Polyethylene (PE)	ASTM F405; ASTM F810
Polyvinyl chloride (PVC)	ASTM D2729
Styrene rubber (SR)	ASTM D3298

TABLE 84.30-5
EFFLUENT DISTRIBUTION PIPING FOR
PRESSURIZED SOIL ABSORPTION SYSTEMS

Material	Standard
Acrylonitrile-butadiene styrene (ABS)- Schedule 40	ASTM D2661; ASTM D1527
Polyvinyl chloride (PVC)- Schedule 40	ASTM D2665; ASTM D1785

(3) STORM AND CLEAR WATER DRAIN AND VENT SYSTEMS. Storm and clear water drain and vent systems shall be of such material and workmanship as set forth in this subsection.

(a) Above ground drain and vent pipe. Drain pipe and vent pipe installed above ground and inside a building shall conform to one of the standards listed in Table 84.30-1, except black steel pipe conforming to ASTM A53 or ASTM A120 may be used for storm water conductors. Black steel conductors may not be embedded in concrete or masonry.

(b) Underground drain and vent pipe. Drain pipe and vent pipe installed underground shall conform to one of the standards listed in Table 84.30-2.

(c) Storm building sewer pipe. Storm building sewer pipe shall conform to one of the standards listed in Table 84.30-6.

(d) Subsoil drain pipe. Subsoil drains shall be open jointed, horizontally split, or perforated pipe conforming to one of the standards listed in Table 84.30-7.

(e) Roof drains. 1. Roof drains shall be provided with removable strainers of sufficient strength to carry the anticipated loads.

2. Roof drains shall be so constructed that the drains can be cleaned and the drain inlets accessible at all time.

3. Roof drains shall be sized in accordance with ILHR 82.36 and the drain outlet shall not be less than 2-1/2 inches in diameter.

Note: See s. ILHR 82.36 (18) for additional roof drain requirements.

(f) Area drain inlets. Area drain inlets shall be constructed in a water-tight manner of precast concrete, reinforced monolithic concrete, brick or block, cast iron, coated 12 gauge steel, vitrified clay, fiberglass or other approved materials.

TABLE 84.30-6
STORM BUILDING SEWER PIPE AND TUBING

Material	Standard
Acrylonitrile butadiene styrene (ABS) ^a	ASTM D1527; ASTM D2661; ASTM D2751; ASTM F628
Acrylonitrile butadiene styrene (ABS) composite	ASTM 2680
Cast iron	ASTM A74; CISPI 301
Concrete	ASTM C14; ASTM C76
Copper ^b	ASTM B42; ASTM B88
Corrugated steel ^c	FS-WW-P-405a
Polyvinyl chloride (PVC) ^a	ASTM D2665; ASTM D3033; ASTM D3034 ASTM D1785
Vitrified clay	ASTM C700

Note a: Thermoplastic sewer pipe shall be installed in accordance with ASTM D2321.

Note b: Copper tubing, type M, may not be installed underground.

Note c: Corrugated steel pipe may be used for storm building sewers subject to the following conditions:

1. The pipe shall be sized according to ch. ILHR 82 with adjustments considered to allow for flow characteristics and configuration of the pipe; and

2. The pipe may not be installed closer than 10 feet from a building's exterior wall or foundation.

TABLE 84.30-7
SUBSOIL DRAIN PIPE AND TUBING

Material	Standard
Cast iron	ASTM A74; CISPI 301
Clay drain tile	ASTM C4
Polyethylene (PE)	ASTM F405
Polyvinyl chloride (PVC)	ASTM D2729 (Perforated only)
Styrene rubber (SR)	ASTM D3298
Vitrified clay	ASTM C700

(4) WATER SUPPLY SYSTEMS. Water supply systems shall be of such material and workmanship as set forth in this subsection. All materials in contact with water, in a water supply system, shall be suitable for use with potable water.

(a) Water quality. A water supply system shall be resistive to corrosive action and degrading action from the water being conveyed.

(b) Soil and groundwater. The installation of water supply systems shall be prohibited in soil and groundwater that is contaminated with solvents, fuels, organic compounds or other detrimental materials which will cause permeation, corrosion, degradation, or structural failure of the piping material.

1. Where detrimental conditions are suspected, a chemical analysis of the soil and groundwater conditions shall be required to ascertain the acceptability of the proposed water supply system materials for the specific installation.

2. Where a detrimental condition exists, no underground water supply system may be installed until the detrimental condition can be:

a. Eliminated and the source of the condition can be eliminated;

b. Identified and the pipe and joining method can be proven resistant to the detrimental condition; or

c. Avoided by choosing an alternate route that will not be affected by the detrimental condition.

(c) Certification of plastic pipe. Plastic pipe for a water supply system shall conform to NSF 14 and shall be certified by a nationally recognized testing agency as to conforming to NSF 14. Plastic pipe for water supply systems shall bear the certification mark of the testing agency.

(d) Water services and private water mains. 1. Water service pipe and private water mains shall conform to one of the standards listed in Table 84.30-8. Pipe and tubing for water services and private water mains shall have a minimum working pressure of 150 psig at 73.4°F.

2. A local governmental unit may by ordinance restrict the types of materials for water services and private water mains which are to be located within or beneath an area subject to an easement for a highway, street or public service right-of-way. Before adopting an ordinance restricting the types of materials for water services the local governmental unit shall submit a copy of the proposed ordinance to the department for review and approval.

3. Existing metallic water service piping or water distribution piping used for electrical grounding shall not be replaced with nonmetallic pipe or tubing until other approved electrical grounding means are provided.

(e) Water distribution pipe. 1. Except as provided in subd. 2., water distribution pipe shall have a minimum working pressure of 100 psig at 180°F and shall conform to one of the standards listed in Table 84.30-9.

2. Water distribution pipe installed underground for an exterior turf sprinkler system shall conform to one of the standards listed in Table 84.30-10. Water distribution pipe and fittings for exterior turf sprinkler systems shall have a minimum working pressure of 100 psig at 73.4°F. Water distribution pipe installed above ground for an exterior turf sprinkler system shall conform to subd. 1.

Note: Portions of a water supply system that supply water to a fire sprinkler system are to also conform to the requirements specified in s. ILHR 51.23.

(f) 1. The bending of polybutylene water service pipe or tubing shall be in accordance with the manufacturer's instructions.

2. a. The bending radius of polybutylene water distribution pipe or tubing shall meet or exceed the bending radius specified in Table 84.30-9m and shall meet or exceed the bending radius specified by the manufacturer of the pipe or tubing.

b. Polybutylene water distribution pipe or tubing shall be supported or anchored at the beginning and end of long bends in accordance with the manufacturer's instructions.

TABLE 84.30-8
PIPE AND TUBING FOR
WATER SERVICES AND PRIVATE WATER MAINS

Material	Standard
Acrylonitrile butadiene styrene (ABS) ^a	ASTM D1527; ASTM D2282
Brass	ASTM B43
Cast iron	ASTM A377; AWWA C115/A21.15
Chlorinated polyvinyl chloride (CPVC) ^a	ASTM D2846; ASTM F441; ASTM F442; ASTM F443
Copper ^b	ASTM B42; ASTM B88
Ductile iron	ASTM A377; AWWA C115/A21.15; AWWA C151/A21.51
Galvanized steel	ASTM A53; ASTM A120
Polybutylene (PB) ^a	ASTM D2662; ASTM D2666; ASTM D3000 ASTM D3309
Polyethylene (PE) ^a	ASTM D2239; ASTM D2737; ASTM D2104; ASTM D2447; ASTM D3035
Polyvinyl chloride (PVC) ^a	ASTM D1785; ASTM D2241; ASTM D2740; ASTM D2672; AWWA C900
Stainless steel	ANSI B36.19

Note a: Plastic water service systems shall be installed in accordance with ASTM D2774. See Appendix for further explanatory material.

TABLE 84.30-9
WATER DISTRIBUTION PIPE AND TUBING

Material	Standard
Brass	ASTM B43
Cast iron	ASTM A377; AWWA C115/A21.15
Chlorinated polyvinyl chloride (CPVC) ^a	ASTM D2846
Copper ^b	ASTM B42; ASTM B88
Ductile iron	ASTM A377; AWWA C115/A21.15; AWWA C151/A21.51
Galvanized steel	ASTM A53; ASTM A120
Polybutylene (PB) ^a for agricultural use and pure-water use	ASTM D3309
Stainless steel	ANSI B36.19M; ASTM A270; ASTM A450

Note a: Plastic pipe and tubing installed underground shall be in accordance with ASTM D2774. See Appendix for further explanatory material.

Note b: Copper tubing, type M, may not be installed underground.

TABLE 84.30-9m
MINIMUM BENDING RADIUS OF POLYBUTYLENE
WATER DISTRIBUTION PIPE AND TUBING

Pipe Size (inches)	Bending Radius (inches)	Tubing Size (inches)	Bending Radius (inches)
3/4	12-3/4	1/4	4-1/2
1	15-3/4	3/8	6
1-1/4	20	1/2	7-1/2
1-1/2	23	3/4	10-1/2
2	28-1/2	1	13-1/2
		1-1/4	16-1/2
		1-1/2	19-1/2
		2	25-1/2

Note: See Appendix for further explanatory material.

TABLE 84.30-10
EXTERIOR TURF SPRINKLER SYSTEM PIPE AND TUBING

Material	Standard
Acrylonitrile-butadiene styrene (ABS) ^a	ASTM D1527, D2282
Brass	ASTM B43
Cast iron	ASTM A377; AWWA C115/A21.15
Chlorinated polyvinyl chloride (CPVC) ^a	ASTM F441; ASTM F442; ASTM F443; ASTM D2846
Copper ^b	ASTM B88
Ductile iron	ASTM A377; AWWA C115/A21.15; AWWA C151/A21.51
Galvanized steel	ASTM A53; ASTM A120
Polybutylene (PB) ^a	ASTM D2666; ASTM D3000; ASTM D2662; ASTM D3309
Polyethylene (PE) ^a	ASTM D2104; ASTM D2239; ASTM D2447; ASTM D3035; ASTM D2737
Polyvinyl chloride (PVC) ^a	ASTM D1785; ASTM D2241; ASTM D2672; AWWA C900; ASTM D2740

Note a: Plastic pipe and tubing installed underground shall be in accordance with ASTM D2774. See Appendix for further explanatory material.

Note b: Copper tubing, type M, may not be installed underground.

(5) PIPE FITTINGS AND VALVES. (a) Fittings. Pipe fittings shall conform to the pipe material standards listed in this chapter or one of the standards listed in Table 84.30-11. Threaded drain pipe fittings shall be of the recessed drainage type.

(b) Water supply valves. 1. Control valves for water services and private water mains shall be designed and constructed to withstand a minimum pressure of 125 psig at 73.4°F.

2. Control valves for water distribution systems shall be designed and constructed to withstand a minimum pressure of 100 psig at 180°F.

3. A control valve for water supply piping 3/4 inches through 4 inches in diameter which serves 2 or more plumbing fixtures shall have a nominal diameter at least equal to the piping and shall have a minimum Cv factor as specified in Table 84.30-10a.

84.30-10a
MINIMUM Cv FACTORS

Nominal Valve Diameters	Cv Factors
3/4	18
1	35.5
1-1/4	61
1-1/2	107
2	175
3	255
4	340

Note: The Cv factor is defined as the flow coefficient for valves, expressing the flow rate in gallons per minute of 60° with a one psi pressure drop across the valve.

(c) Special fittings and valves. 1. Water hammer arrestors shall conform to ANSI A112.26.1 or ASSE 1010.

2. Relief valves and automatic gas shutoff devices for hot water supply systems shall conform to ANSI Z21.22.

3. Water pressure reducing valves and strainers for water pressure reducing valves for domestic supply systems shall conform to ASSE 1003.

4. Hose connection vacuum breakers shall conform to ASSE 1011 or ASSE 1019.

5. Backflow preventers with intermediate atmospheric vents shall conform to ASSE 1012.

6. Reduced pressure principle backflow preventers shall conform to ASSE 1013.

7. Backwater valves shall conform to ANSI A112.14.1.

8. Pipe applied atmospheric type vacuum breakers shall conform to ASSE 1001.

9. Laboratory faucet vacuum breakers shall conform to ASSE 1035.

10. Trap seal primer valves shall conform to ASSE 1018.

(d) Pipe saddles. Pipe saddles shall be installed in accordance with the instructions of the saddle manufacturer and the following limitations:

1. Pipe saddles may be installed on private interceptor main sewers, building sewers, underground drain and vent pipe and tubing, and where otherwise approved by the department.

2. A saddle for drain piping shall have a radius in accordance with s. ILHR 82.30 (8) (a);

3. The material of the saddle shall be compatible with the materials of the pipes which are to be connected to the saddle.

4. The hole in the pipe which is to receive the saddle shall be drilled or cored to match the saddle outlet;

5. Straps or clamps which wrap around the pipe and saddle shall be provided by the manufacturer of the saddle;

6. Saddles shall be installed with straps or clamps which wrap around the pipe and saddle; and

7. Proper hangers or bedding shall be provided to maintain alignment between the opening in the pipe and the saddle.

TABLE 84.30-11
PIPE FITTINGS

Material	Standard
Acrylonitrile butadiene styrene (ABS)	ASTM D2465; ASTM D2468; ASTM D2469; ASTM D3311; ASTM F409
Cast bronze	ANSI B16.15; ANSI B16.24
Cast copper alloy	ANSI B16.18; ANSI B16.23; ANSI B16.26; ANSI B16.32
Cast iron	ANSI B16.4; ANSI B16.12; ANSI B16.1
Chlorinated polyvinyl chloride (CPVC)	ASTM F437; ASTM F438; ASTM F439
Copper	ANSI B16.22; ANSI B16.29; ANSI B16.43
Ductile iron and gray iron	ANSI/AWWA C110/A21.10; ANSI/AWWA C153/A21.53; ANSI B16.42
Malleable iron	ANSI B16.3
Polybutylene (PB)	ASTM D3309; ASTM F845
Polyethylene (PE)	ASTM D2609; ASTM D2683; ASTM D3197; ASTM D3261
Polyvinyl chloride (PVC)	ASTM D2464; ASTM D2466; ASTM D2467; ASTM D3036; ASTM D3311; ASTM F409
Stainless steel	ASTM A403
Steel ^a	ANSI B16.5; ANSI B16.9; ANSI B16.11; ANSI B16.28
Styrene-rubber (SR)	ASTM D2852

Note a: Steel fittings and malleable iron fittings to be used in a water supply system shall be galvanized-coated in accordance with ASTM A123.

(6) SPECIAL MATERIALS. (a) Sheet lead. Sheet lead for the following uses may not weigh less than indicated in subds. 1. to 3.

1. Safe pans, 4 pounds per square foot;
2. Site-fabricated flashings for vent pipes, 3 pounds per square foot; and
3. Prefabricated flashings for vent pipes, 2-1/2 pounds per square foot.

(b) Traps and fixture drain connection fittings. Copper or tubular brass traps and fixture drain connections fittings shall be at least of 20 gage material.

(c) Sheet copper. Sheet copper for the following uses may not weigh less than indicated in subds. 1. and 2. and shall conform to ASTM B152.

1. Safe pans, 12 ounces per square foot;
2. Flashing for vent pipes, 8 ounces per square foot; and
3. Flush tank linings, 10 ounces per square foot.

(d) Cleanout plugs. Cleanout plugs shall be of brass or plastic. Brass cleanout plugs shall be used with metallic piping only and shall conform to ASTM A74. Plastic cleanout plugs shall conform to the requirements of sub. (5) (a).

(e) Flush pipes and fittings. Flush pipes and fittings shall be of non-ferrous material and shall conform to ANSI A112.19.5.

(f) Safing materials. Safing materials made from chlorinated polyethylene shall conform to ASTM D4068.

ILHR 84.40 JOINTS AND CONNECTIONS. (1) GENERAL. (a) Tightness. Joints and connections in the plumbing system shall be watertight and gastight for the pressure required by test or the system design, whichever is greater, with the exception of perforated or open joint piping.

Note: The testing requirements for tightness are in s. ILHR 82.21.

(b) Preparation of pipe ends. Pipe ends shall be prepared in accordance with the applicable pipe standard or the pipe or fitting manufacturer's instructions.

(c) Prohibited joints and connections. Unless otherwise permitted in this chapter or ch. ILHR 82 or 83, the following types of joints and connections shall be prohibited:

1. Cement or concrete joints;
2. Mastic or hot poured bituminous joints;

3. Elastomeric rolling o-rings between different diameter pipes;
4. Solvent cement joints between different types of plastic pipe; and
5. Roll grooving of galvanized steel pipe.

(2) ABS PLASTIC PIPE. Joints between acrylonitrile butadiene styrene plastic pipe or fittings shall be installed in accordance with pars. (a) to (c).

(a) Mechanical joints. Mechanical joints shall be installed in accordance with the manufacturer's instructions.

1. 'Drain and vent systems.' Mechanical push-on joints for drain and vent systems shall conform to ASTM D3212.

2. 'Water supply systems.' Mechanical push-on joints and mechanical compression-type joints for water supply systems which use a flexible elastomeric seal shall conform to ASTM D3139.

(b) Solvent cemented joints. Solvent cemented joints shall be made in accordance with ASTM D2235 and its appendix, ASTM D2661 or ASTM F628.

1. Joint surfaces shall be clean and free of moisture.

2. Solvent cement conforming to ASTM D2235 shall be applied to all joint surfaces and the joint shall be made while the cement is wet.

3. Solvent cement shall be handled in accordance with ASTM F402.

4. Solvent cement used on pipes and fittings of a water supply system shall conform to NSF 14 and shall be certified by a nationally recognized testing agency as to conforming to NSF 14. The container for the solvent cement shall bear the certification mark of the testing agency.

Note: See Appendix for further explanatory material.

(c) Threaded joints. Threaded joints shall only be used on pipes of schedule 80 or heavier. Threaded joints shall conform to ANSI B1.20.1. The pipe shall be threaded with dies specifically designed for plastic pipe. Thread lubricant or tape approved for such use shall be applied to the male threads only.

(3) BLACK STEEL PIPE. Joints between black steel pipe or fittings shall be in accordance with pars. (a) to (d).

(a) Threaded joints. Threaded joints shall conform to ANSI B1.20.1. Pipe joint compound or tape shall be used on the male threads only.

(b) Mechanical joints. Mechanical joints shall be installed in accordance with the manufacturer's instructions.

(c) Caulked joints. Caulked joints shall only be used for drain or vent piping. Caulked joints for hub and spigot piping and fittings shall be firmly packed with oakum or hemp. Molten lead shall be poured in one operation not less than one inch deep and not to extend more than 1/8 inch below the rim of the pipe, and caulked tight. Paint, varnish or other coatings may not be used on the joining material until after the joint has been tested and approved.

1. Caulked joints for drain piping shall be used only in a vertical position.

2. Caulked joints for vent piping may be used for piping in a vertical or horizontal position.

(d) Welded joints. Joints between black steel pipe or fittings may be welded.

(4) BRASS PIPE. Joints between brass pipe or fittings shall be in accordance with the provisions of pars. (a) to (d).

(a) Brazed joints. All joint surfaces to be brazed shall be cleaned bright by other than chemical means. Brazing filler metal conforming to AWS A5.8 or other approved material shall be used. The joining of water supply piping shall be made with lead-free materials. "Lead-free" shall mean a chemical composition equal to or less than 0.2% of lead.

(b) Mechanical joints. Mechanical joints shall be installed in accordance with the manufacturer's instructions. Mechanical push-on joints and mechanical compression type joints for water supply systems which use flexible elastomeric seals shall conform to ASTM D3139.

(c) Soldered joints. All joint surfaces to be soldered shall be cleaned bright by other than chemical means. A nontoxic flux shall be applied to all joint surfaces. Solder conforming to ASTM B32 or other approved material shall be used. The joining of water supply piping shall be made with lead-free materials. "Lead-free" shall mean a chemical composition equal to or less than 0.2% of lead.

(d) Threaded joints. Threaded joints shall conform to ANSI B1.20.1. Pipe joint compound or tape shall be used on the male threads only.

(5) CAST IRON PIPE. Joints between cast iron pipe or fittings shall be installed in accordance with pars. (a) and (b).

(a) Caulked joints. 1. 'Drain and vent systems.' Caulked joints for hub and spigot pipe of drain and vent systems shall be firmly packed with oakum or hemp. Molten lead shall be poured in one operation not less than one inch deep and not to extend more than 1/8 inch below the rim of the pipe, and caulked tight. Paint, varnish or other coatings may not be used on the joining material until after the joint has been tested and approved.

2. 'Water supply systems.' Joints for bell and spigot pipe of water supply systems shall be firmly packed with treated paper rope. Molten lead shall be poured in one operation to a depth of 2-1/2 inches.

(b) Mechanical joints. 1. 'Drain and vent systems.' a. Mechanical push-on joints for drain and vent systems shall have gaskets which conform to ASTM C564.

b. Mechanical sleeve joints for drain and vent systems shall have a rubber sealing sleeve conforming to ASTM C564 or CISPI 310. Where a stainless steel band assembly is used, the band assembly shall conform to CISPI 310. Mechanical joints shall be installed in accordance with the manufacturer's instructions.

2. 'Water supply systems.' Mechanical push-on joints and mechanical compression type joints for water supply systems shall conform to AWWA C111/A21.11. Lead tipped gaskets may not be used.

(c) Threaded joints. Threaded joints shall conform to ANSI B1.20.1. Pipe joint compound or tape shall be used on the male threads only.

(6) CPVC PLASTIC PIPE. Joints between chlorinated polyvinyl chloride plastic pipe or fittings shall be installed in accordance with the provisions of pars. (a) to (c).

(a) Mechanical joints. Mechanical joints shall be installed in accordance with the manufacturer's instructions. Mechanical push-on type joints which use flexible elastomeric seals shall conform to ASTM D3139.

(b) Solvent cemented joints. Solvent cemented joints shall be made in accordance with ASTM D2846 and its Appendix or ASTM F493 and its Appendix.

1. Joint surfaces shall be clean and free of moisture. A primer conforming to ASTM F656 shall be applied to all joint surfaces. The primer shall be purple in color.

2. Solvent cement conforming to ASTM F493 shall be applied to all joint surfaces and the joint shall be made while the cement is wet.

3. Solvent cement shall be handled in accordance with ASTM F402.

4. Solvent cement shall be orange in color.

5. Primer and solvent cement used on pipes and fittings of a water supply system shall conform to NSF 14 and shall be certified by a nationally recognized testing agency as to conforming to NSF 14. The containers for the primer and the solvent cement shall bear the certification mark of the testing agency.

Note: See Appendix for further explanatory material.

(c) Threaded joints. Threaded joints shall only be used on pipes of schedule 80 or heavier. Threaded joints shall conform to ANSI B1.20.1. The pipe shall be threaded with dies specifically designed for plastic pipe. Thread lubricant or tape approved for such use shall be applied to the male threads only.

(7) CONCRETE PIPE. Joints between concrete pipe or fittings shall be made by use of an elastomeric seal conforming to ASTM C443.

(8) COPPER PIPE AND TUBING. Joints between copper pipe, tubing or fittings shall be installed in accordance with pars. (a) to (e).

(a) Brazed joints. All joint surfaces to be brazed shall be cleaned bright by other than chemical means. Brazing filler metal conforming to AWS A5.8 or other approved material shall be used. The joining of water supply piping shall be made with lead-free materials. "Lead-free" shall mean a chemical composition equal to or less than 0.2% of lead.

(b) 'Flared joints.' Flared joints may be used on annealed tubing for water supply systems and shall be made by the use of a tool designed for that operation.

(c) Mechanical joints. Mechanical joints shall be installed in accordance with the manufacturer's instructions. Mechanical push-on joints and mechanical compression type joints for water supply systems which use flexible elastomeric seals shall conform to ASTM D3139.

(d) Soldered joints. All joint surfaces to be soldered shall be cleaned bright by other than chemical means. A nontoxic flux shall be applied to all joint surfaces. Solder conforming to ASTM B32 or other approved material shall be used. The joining of water supply piping shall be made with lead-free materials. "Lead-free" shall mean a chemical composition equal to or less than 0.2% of lead.

(e) Threaded joints. Threaded joints shall conform to ANSI B1.20.1. Pipe joint compound or tape shall be used on the male threads only.

(9) DUCTILE IRON PIPE. (a) Mechanical joints. Mechanical push-on joints and mechanical compression type joints for water supply systems shall conform to AWWA C111/A21.11. Lead tipped gaskets may not be used.

(b) Threaded joints. Threaded joints shall conform to ANSI B1.20.1. Pipe joint compound or tape shall be used on the male threads only.

(10) GALVANIZED STEEL PIPE. Joints between galvanized steel pipe or fittings or between galvanized steel pipe and cast iron fittings shall be installed in accordance with pars. (a) to (c).

(a) Threaded joints. Threaded joints shall conform to ANSI B1.20.1. Pipe joint compound or tape shall be used on the male threads only.

(b) Mechanical joints. Mechanical joints shall be installed in accordance with the manufacturer's instructions. Mechanical push-on joints and mechanical compression type joints for water supply systems which use flexible elastomeric seals shall conform to ASTM D3139.

(c) Caulked joints. Caulked joints shall only be used for drain or vent piping. Caulked joints for hub and spigot piping and fittings shall be firmly packed with oakum or hemp. Molten lead shall be poured in one operation not less than one inch deep and not to extend more than 1/8 inch below the rim of the pipe, and caulked tight. Paint, varnish or other coatings may not be used on the joining material until after the joint has been tested and approved.

1. Caulked joints for drain piping shall be used only for piping in a vertical position.

2. Caulked joints for vent piping may be used for piping in a vertical or horizontal position.

(11) LEAD PIPE. Joints between lead pipe or fittings shall be installed in accordance with pars. (a) and (b).

(a) Burned joints. Burned joints shall be uniformly fused together into one continuous piece. The thickness of the joint shall be at least as thick as the lead being joined. The filler metal shall be of the same material as the pipe.

(b) Wiped joints. A wiped joint shall be full wiped, having an exposed surface on each side of the joint not less than 3/4 inch and shall be at least 3/8 inch thick at the thickest point.

(12) PB PLASTIC PIPE AND TUBING. Joints between polybutylene plastic pipe and tubing or fittings shall be installed in accordance with pars. (a) to (c).

(a) Flared joints. Flared joints shall be made by use of a tool designed for that operation. Flared joints shall be made in accordance with ASTM D3140.

(b) Heat fusion joints. Heat fusion joints shall be made in accordance with ASTM D2657 and ASTM D3309. Heat fusion joints shall be of a socket fusion type.

1. Joint surfaces to be fused shall be clean and free of moisture.

2. All joint surfaces shall be heated to the temperature recommended by the pipe or fitting manufacturer and joined.

3. The joint shall be undisturbed until cool.

(c) Mechanical joints. Mechanical joints shall be installed in accordance with the manufacturer's instructions. Mechanical push-on joints and mechanical compression type joints which use flexible elastomeric seals shall conform to ASTM D3139.

(13) PE PLASTIC PIPE AND TUBING. Joints between polyethylene plastic pipe, tubing or fittings shall be in accordance with pars. (a) to (c).

(a) Flared joints. Flared joints shall be made by use of a tool designed for that operation. Flared joints shall be made in accordance with ASTM D3140.

(b) Heat fusion joints. Heat fusion joints shall be made in accordance with ASTM D2657. Heat fusion joints shall be of a socket fusion type.

1. Joint surfaces to be fused shall be clean and free of moisture.

2. All joint surfaces shall be heated to the temperature recommended by the pipe or fitting manufacturer and joined.

3. The joint shall be undisturbed until cool.

(c) Mechanical joints. Mechanical joints may be installed in accordance with the manufacturer's instructions. Mechanical push-on joints and mechanical compression type joints which use flexible elastomeric seals shall conform to ASTM D3139.

(14) PVC PLASTIC PIPE. Joints between polyvinyl chloride plastic pipe or fittings shall be in accordance with pars. (a) to (c).

(a) Mechanical joints. Mechanical joints shall be installed in accordance with the manufacturer's instructions.

1. 'Drain and vent systems.' Mechanical push-on joints for drain and vent systems shall conform to ASTM D3212.

2. 'Water supply systems.' Mechanical push-on joints and mechanical compression type joints for water supply systems which use flexible elastomeric seals shall conform to ASTM D3139.

(b) Solvent cemented joints. Solvent cemented joints shall be made in accordance with ASTM D2855.

1. Joint surfaces shall be clean and free of moisture. A primer conforming to ASTM F656 shall be applied to all joint surfaces.

2. Solvent cement conforming to ASTM D2564 shall be applied to all joint surfaces and the joint shall be made while the cement is wet.

3. Solvent cement shall be handled in accordance with ASTM F402.

4. Primer and solvent cement used on pipes and fittings of a water supply system shall conform to NSF 14 and shall be certified by a nationally recognized testing agency as to conforming to NSF 14. The containers for the primer and the solvent cement shall bear the certification mark of the testing agency.

Note: See Appendix for further explanatory material.

(c) Threaded joints. Threaded joints shall only be used on pipes of schedule 80 or heavier. Threaded joints shall conform to ANSI B1.20.1. The pipe shall be threaded with dies specifically designed for plastic pipe. Thread lubricant or tape approved for such use shall be applied to the male threads only.

(15) STAINLESS STEEL. Joints between stainless steel pipe or fittings shall be installed in accordance with the provisions of pars. (a) to (c).

(a) Mechanical joints. Mechanical joints shall be installed in accordance with the manufacturer's instructions. Mechanical push-on type joints which use flexible elastomeric seals shall conform to ASTM D3139.

(b) Threaded joints. Threaded joints shall conform to ANSI B1.20.1. Pipe joint compound or tape shall be used on the male threads only.

(c) Welded joints. Joints between stainless steel pipe or fittings may be welded.

(16) VITRIFIED CLAY PIPE. Joints between vitrified clay pipe or fittings shall be made by use of elastomeric seals conforming to ASTM C425.

(17) JOINTS BETWEEN PIPE AND FITTINGS OF DIFFERENT MATERIALS. Connections between pipes of different materials shall be made with mechanical compression type joints, installed in accordance with manufacturer's instructions or as specified in pars. (a) to (e).

(a) Copper to cast iron. Connections between copper pipe or tube and cast iron pipe shall be by means of either caulked joints in accordance with sub. (5) (a) or threaded fittings in accordance sub. (5) (c).

(b) Copper to galvanized steel. Connections between copper pipe or tube and galvanized steel pipe shall be by use of an adapter fitting. The copper pipe shall be soldered to the adapter in accordance with sub. (8) (d). The galvanized steel shall be threaded to the adapter in accordance with sub. (10) (a).

(c) Cast iron to steel or brass pipe. Connections between cast iron pipe and galvanized or black steel or brass pipe shall be by means of:

1. Caulked joints in accordance with sub. (5) (a); or
2. Threaded joints in accordance with sub. (5) (c).

(d) Plastic to other materials. 1. Connections between plastic pipe and cast iron pipe shall be by means of:

- a. Caulked joints in accordance with sub. (5) (a); or
- b. Threaded joints in accordance with sub. (5) (c).

2. Connections between different types of plastic pipe or between plastic pipe and other piping materials other than cast iron shall be by means of threaded joints in accordance with sub. (14) (c).

(e) Lead to other piping materials. Connections between lead pipe and other piping materials shall be by use of an adapter fitting conforming to s. ILHR 84.30 (5) (a). The lead pipe shall be caulked or burned to the adapter fitting in accordance with sub. (11).

(18) CONNECTION OF FIXTURES. Flanged fixtures which have integral traps shall be mechanically fastened to the drain piping by means of a compatible fitting. The joint between the fixture and the fitting shall be sealed with a watertight gasket or setting compound.

ILHR 84.50 ALTERNATE APPROVALS AND EXPERIMENTAL APPROVALS. (1) GENERAL. The provisions of chs. ILHR 82 to 84 are not intended to prevent the use of a plumbing material or product not specifically addressed therein if the plumbing material or product has been approved by the department.

(2) ALTERNATE APPROVAL. (a) Plumbing materials or products determined by the department to comply with the intent of chs. ILHR 82 to 84 and ch. 145, Stats., and not approved under s. ILHR 84.10, shall be issued an alternate approval. Alternate approvals shall be issued by the department in writing.

(b) The department may require the submission of any information deemed necessary for review. Sufficient evidence shall be submitted to the department to substantiate:

1. Assertions of function and performance; and

2. Compliance with the intent of chs. ILHR 82 to 84 and ch. 145, Stats.

(c) The department shall review and make a determination on an application for alternate approval within 3 months of receipt of all information and fees required to complete the review.

(d) The department may impose specific conditions in issuing an alternate approval, including an expiration date for the alternate approval. Violations of the conditions under which an alternate approval is issued shall constitute a violation of this chapter.

(e) If, upon review, the department determines that a plumbing material or product does not comply with the intent of chs. ILHR 82 to 84 and ch. 145, Stats., the request for alternate approval shall be denied in writing.

(3) EXPERIMENTAL APPROVAL. (a) The department may allow the installation of a plumbing material or product for the purpose of proving compliance with the intent of chs. ILHR 82 to 84 and ch. 145, Stats.

(b) An experimental approval shall be required for each plumbing material or product to be installed for the purpose of proving compliance with the intent of chs. ILHR 82 to 84 and ch. 145, Stats. A separate experimental approval shall be obtained for each project where such a product is to be used. Experimental approvals shall be issued by the department in writing. Experimental approvals shall be denied by the department in writing.

(c) The department may require the submission of any information deemed necessary for review.

(d) The department may limit the number of applications it will accept for experimental approval of products.

(e) The department shall review and make a determination on an application for experimental approval within 6 months of receipt of all information and fees required to complete the review.

(f) The department may impose specific conditions in issuing an experimental approval. Violations of the conditions under which an experimental approval is issued shall constitute a violation of this chapter.

(g) If the department issues an experimental approval:

1. Plans detailing the installation of the plumbing material or product shall be submitted to the department in accordance with s. ILHR 82.20 (4) or 83.07 (2).

2. A copy of the experimental approval shall be attached to the submitted plans and approved plans.

3. A letter of consent from the owner of the installation shall be attached to the submitted plans and approved plans. The letter shall acknowledge that the owner has received and read a copy of the experimental approval and s.ILHR 84.50.

4. The completed installation shall be inspected for compliance with the approved plans by the department. A report on the completed installation shall be written by the department.

5. A written report, from the party who was issued the experimental approval, shall be submitted to the department detailing the function and performance of the installed plumbing material or product. The report shall be completed at time intervals specified by the department, but not less than once a year.

6. On-site inspections shall be performed by the department at time intervals specified by the department, but not less than once a year. A report on the inspection shall be written by the department. The department may assess a fee for the inspection.

7. Five years after the date of the completed installation the department shall within 6 months order the removal of the plumbing material or product or issue an alternate approval.

(h) If chs. ILHR 82 to 84 or ch. 145, Stats., are revised to include or permit an experimental plumbing material or product to conform with the intent of chs. ILHR 82 to 84 and ch. 145, Stats., the department shall waive the requirements of par. (f) as to that material or product.

(4) MODIFICATIONS. If a plumbing material or product with an alternate or experimental approval or the installation of an experimentally approved plumbing material or product is modified or additional assertions of function or performance are made, the alternate or experimental approval shall be considered null and void, unless the product is resubmitted to the department for review and the approval is reaffirmed.

(5) REVOCATION. The department may revoke an alternate or experimental approval issued under this section for any false statements or misrepresentations of facts or data on which the alternate or experimental approval was based or as a result of product failure.

(6) LIMITATIONS. An alternate or experimental approval of a plumbing material or product issued by the department may not be construed as an assumption of any responsibility for defects in design, construction, or performance of any plumbing material or product nor for any damages that may result.

(7) FEES. Fees for the review of a plumbing material or product under this section and any required on-site inspections shall be submitted in accordance with s. Ind 69.23 (5) (c) or (d), and (e).

ILHR 84.60 INCORPORATION OF STANDARDS BY REFERENCE. (1) CONSENT. Pursuant to s. 227.025, Stats., the attorney general and the revisor of statutes have consented to the incorporation by reference of the standards listed in sub. (4).

(2) COPIES. Copies of the adopted standards are on file in the offices of the department, the secretary of state and the revisor of statutes. Copies may be purchased through the respective organizations listed in Tables 84.60-1 to 84.60-10.

(3) INTERIM AMENDMENTS. Interim amendments of the adopted standards shall have no effect in the state until such time as this section is correspondingly revised to reflect the changes.

(4) ADOPTION OF STANDARDS. The standards referenced in Tables 84.60-1 to 84.60-10 are hereby incorporated by reference into this chapter.

Table 84.60-1

Standard Reference Number	Title
AHAM	Association of Home Appliance Manufacturers 20 North Wacker Drive Chicago, Illinois 60606
DW-1-82	Household Dishwashers

TABLE 84.60-2

ANSI Standard Reference Number	American National Standards Institute, Inc. 1430 Broadway New York, New York 10018 Title
1. A112.6.1M-79	Supports for Off-the-Floor Plumbing Fixtures for Public Use
2. A112.14.1-75	Backwater Valves
3. A112.18.1M-79	Finished and Rough Brass Plumbing Fixture Fittings
4. A112.19.1M-79	Enameled Cast Iron Plumbing Fixtures
5. A112.19.2M-82	Vitreous China Plumbing Fixtures
6. A112.19.3-76	Stainless Steel Plumbing Fixtures (Designed for Residential Use)
7. A112.19.4-77	Porcelain Enameled Formed Steel Plumbing Fixtures
8. A112.19.5-79	Trim for Water Closet Bowls, Tanks and Urinals (Dimensional Standards)
9. A112.21.1M-80	Floor Drains
10. A112.21.2-71	Roof Drains
11. A112.26.1-84	Water Hammer Arrestors
12. B1.20.1-83	Pipe Threads, General Purpose (Inch)
13. B16.1-75	Cast Iron Pipe Flanges and Flanged Fittings, Class 25, 125, 250, and 800
14. B16.3-77	Malleable Iron Threaded Fittings, Class 150 and 300
15. B16.4-77	Cast Iron Threaded Fittings, Class 125 and 250
16. B16.5-81	Pipe Flanges and Flanged Fittings, Steel Nickel Alloy and Other Special Alloys
17. B16.9-78	Factory-Made Wrought Steel Butt Welding Fittings
18. B16.11-80	Forged Steel Fittings, Socket-Welded and Threaded
19. B16.12-83	Cast Iron Threaded Drainage Fittings
20. B16.15-78	Cast Bronze Threaded Fittings, Class 125 and 250
21. B16.18-78	Cast Copper Alloy Solder-Joint Pressure Fittings
22. B16.22-80	Wrought Copper and Copper Alloy Solder Joint Pressure Fittings
23. B16.23-76	Cast Copper Alloy Solder Joint Drainage Fittings (DWV)
24. B16.24-79	Bronze Pipe Flanges and Flanged Fittings, Class 150 and 300
25. B16.26-83	Cast Copper Alloy Fittings for Flared Copper Tubes
26. B16.28-78	Wrought Steel Butt Welding Short Radius Elbows and Returns
27. B16.29-80	Wrought Copper and Wrought Copper Alloy Solder Joint Drainage Fittings (DWV)
28. B16.32-79	Cast Copper Alloy Solder Joint Fittings for Solvent Drainage Systems
29. B16.42-79	Fittings, Class 150 and 300. Ductile Iron Pipe Flanges and Flanged
30. B16.43-82	Wrought Copper and Copper Alloy Solder Joint Fittings for Solvent Drainage Systems
31. B36.19M-85	Stainless Steel Pipe
32. Z21.22-79	Relief Valves and Automatic Gas Shutoff Devices for Hot Water Supply Systems
33. Z124.1-80	Plastic Bathtub Units
34. Z124.2-80	Plastic Shower Receptors and Shower Stalls
35. Z124.3-80	Plastic Lavatories
36. Z124.4-83	Plastic Water Closet Bowls and Tanks

TABLE 84.60-3

ARI	Air-Conditioning and Refrigeration Institute 1815 North Fort Myer Drive Arlington, Virginia 22209
Standard Reference Number	Title
ARI-1010-82	Drinking-Fountains and Self-Contained, Mechanically-Refrigerated Drinking-Water Coolers

Table 84.60-4

ASSE	American Society of Sanitary Engineering P.O. Box 9712 Bay Village, Ohio 44140
Standard Reference Number	Title
1. 1001-82	Pipe Applied Atmospheric Type Vacuum Breakers
2. 1002-79	Water Closet Flush Tank Ball Cocks
3. 1003-81	Water Pressure Reducing Valves for Domestic Water Supply Systems
4. 1004-67	Commercial Dishwashing Machines
5. 1005-67	Water Heater Drain Valves, 3/4" Iron Pipe Size
6. 1006-79	Household Dishwashers
7. 1007-79	Home Laundry Equipment
8. 1008-79	Household Food Waste Disposer Units
9. 1009-70	Commercial Food Waste Disposer Units
10. 1010-82	Water Hammer Arrestors
11. 1011-81	Hose Connection Vacuum Breakers
12. 1012-78	Backflow Preventers with Intermediate Atmospheric Vent
13. 1013-80	Reduced Pressure Principle Backflow Preventers, Including Appendix
14. 1014-79	Handheld Showers
15. 1018-78	Trap Seal Primer Valves
16. 1019-78	Wall Hydrants, Frost Proof Automatic Draining, Anti-Backflow Types
17. 1023-79	Hot Water Dispensers, Household Storage Type, Electrical
18. 1025-78	Diverters for Plumbing Faucets with Hose Spray, Anti-Siphon Type, Residential Applications
19. 1035-81	Laboratory Faucet Vacuum Breakers

Table 84.60-5

ASTM		American Society for Testing and Materials 1916 Race Street Philadelphia, Pennsylvania 19103
Standard Reference Number	Title	
1. A53-82	Pipe, Steel, Black and Hot-Dipped, Zinc-Coated Welded and Seamless, Specification for	
2. A74-82	Cast Iron Soil Pipe and Fittings, Specification for	
3. A120-82	Pipe, Steel, Black and Hot-Dipped Zinc-Coated (Galvanized) Welded and Seamless, for Ordinary Uses, Specification for	
4. A123-78	Zinc (Hot-Galvanized) Coatings on Products Fabricated from Rolled, Pressed, and Forged Steel Shapes, Plates and Strip, Specification for	
5. A270-80	Seamless and Welded Austenitic Stainless Steel Sanitary Tubing, Specification for	
6. A377-79	Gray Iron and Ductile Iron Pressure Pipe, Specification for	
7. A403-82a	Wrought Austenitic Stainless Steel Piping Fittings, Specification for	
8. A450-82	General Requirements for Carbon, Ferritic Alloy, and Austenitic Alloy Steel Tubes, Specification for	
9. B32-76	Solder Metal, Specification for	
10. B42-83	Seamless Copper Pipe, Standard Sizes, Specification for	
11. B43-80	Seamless Red Brass Pipe, Standard Sizes, Specification for	
12. B75-81a	Seamless Copper Tube, Specification for	
13. B88-83	Seamless Copper Water Tube, Specification for	
14. B152-83	Copper Sheet, Strip, Plate, and Rolled Bar, Specification for	
15. B251-81	General Requirements for Wrought Seamless Copper and Copper-Alloy Tube, Specification for	
16. B302-81	Threadless Copper Pipe, Specification for	
17. B306-81	Copper Drainage Tube (DWV), Specification for	
18. C4-62(R1981)	Clay Drain Tile, Specification for	
19. C14-82	Concrete Sewer, Storm Drain, and Culvert Pipe, Specification for	
20. C76-83	Reinforced Concrete Culvert, Storm Drain, and Sewer Pipe, Specification for	
21. C425-77(R1982)	Compression Joints for Vitrified Clay Pipe and Fittings, Specification for	
22. C443-79	Joints for Circular Concrete Sewer and Culvert Pipe, Using Rubber Gaskets, Specification for	
23. C564-70(R1982)	Rubber Gaskets for Cast Iron Soil Pipe and Fittings, Specification for	

Table 84.60-5 (continued)

Standard Reference Number	Title
24. C700-78a(R1983)	Vitrified Clay Pipe, Extra Strength, Standard Strength, and Perforated, Specification for
25. D1527-77(R1982)	Acrylonitrile-Butadiene-Styrene (ABS) Plastic Pipe, Schedules 40 and 80, Specification for
26. D1785-83	Poly (Vinyl Chloride) (PVC) Plastic Pipe, Schedules 40, 80 and 120, Specification for
27. D2104-74(R1982)	Polyethylene (PE) Plastic Pipe, Schedule 40, Specification for
28. D2235-81	Solvent Cement for Acrylonitrile-Butadiene-Styrene (ABS) Plastic Pipe and Fittings, Specification for
29. D2239-83	Polyethylene (PE) Plastic Pipe (SIDR-PR) Based on Controlled Inside Diameter, Specification for
30. D2241-83	Poly (Vinyl Chloride) (PVC) Plastic Pipe (SDR-PR), Specification for
31. D2282-82	Acrylonitrile-Butadiene-Styrene (ABS) Plastic Pipe (SDR-PR), Specification for
32. D2321-83a(R1980)	Underground Installation of Flexible Thermoplastic Sewer Pipe, Recommended Practice for
33. D2447-74(R1982)	Polyethylene (PE) Plastic Pipe, Schedules 40 and 80 Based on Outside Diameter, Specification for
34. D2464-76	Threaded Poly (Vinyl Chloride) (PVC) Plastic Pipe Fittings, Schedule 80, Specification for
35. D2465-73(R1979)	Threaded Acrylonitrile-Butadiene-Styrene (ABS) Plastic Pipe Fittings, Schedule 80, Specification for
36. D2466-78	Poly (Vinyl Chloride) (PVC) Plastic Pipe Fittings, Schedule 40, Specification for
37. D2467-76a	Socket-Type Poly (Vinyl Chloride) (PVC) Plastic Pipe Fittings, Schedule 80, Specification for
38. D2468-80	Acrylonitrile-Butadiene-Styrene (ABS), Plastic Pipe Fittings, Schedule 40, Specification for
39. D2469-76	Socket-Type Acrylonitrile-Butadiene-Styrene (ABS) Plastic Pipe Fittings, Schedule 80, Specification for
40. D2564-80	Solvent Cements for Poly (Vinyl Chloride) (PVC) Plastic Pipe and Fittings, Specification for
41. D2609-74	Plastic Insert Fittings for Polyethylene (PE) Plastic Pipe, Specification for
42. D2657-79	Heat-Joining of Polyolefin Pipe and Fittings, Specification for
43. D2661-82	Acrylonitrile-Butadiene-Styrene (ABS) Plastic Drain, Waste, and Vent Pipe and Fittings, Specification for
44. D2662-83	Polybutylene (PB) Plastic Pipe (SIDR-PR), Based on Controlled Inside Diameter, Specification for

Table 84.60-5. (continued)

Standard Reference Number	Title
45. D2665-82	Poly (Vinyl Chloride) (PVC) Plastic Drain, Waste, and Vent Pipe and Fittings, Specification for
46. D2666-83	Polybutylene (PB) Plastic Tubing, Specification for
47. D2672-80	Bell-End Poly (Vinyl Chloride) (PVC) Pipe, Specification for
48. D2680-80	Acrylonitrile-Butadiene-Styrene (ABS) Composite Sewer Piping, Specification for
49. D2683-82	Socket-Type Polyethylene Fittings for Outside Diameter-Controlled Polyethylene Pipe and Tubing, Specification for
50. D2729-83	Poly (Vinyl Chloride) (PVC) Sewer Pipe and Fittings, Specification for
51. D2737-83	Polyethylene (PE) Plastic Tubing, Specification for
52. D2740-80	Poly (Vinyl Chloride) (PVC) Plastic Tubing, Specification for
53. D2751-83a	Acrylonitrile-Butadiene-Styrene (ABS) Sewer Pipe and Fittings, Specification for
54. D2774-72(R1978)	Underground Installation of Thermoplastic Pressure Piping, Recommended Practice for
55. D2846-82	Chlorinated Polyvinyl Chloride (CPVC) Plastic Hot- and Cold-Water Distribution Systems, Specification for
56. D2852-81	Styrene-Rubber (SR) Plastic Drain Pipe and Fittings, Specification for
57. D2855-83	Making Solvent-Cemented Joints with Poly (Vinyl Chloride) (PVC) Pipe and Fittings, Recommended Practice for
58. D3000-73(R1981)	Polybutylene (PB) Plastic Pipe (SDR-PR) Based on Outside Diameter, Specification for
59. D3033-83	Type PSP Poly (Vinyl Chloride) (PVC) Sewer Pipe and Fittings, Specification for
60. D3034-83	Type PSM Poly (Vinyl Chloride) (PVC) Sewer Pipe and Fittings, Specification for
61. D3035-81	Polyethylene (PE) Plastic Pipe (SDR-PR) Based on Controlled Outside Diameter, Specification for
62. D3036-73	Socket-Type Polyvinyl Chloride (PVC) Plastic Line Couplings, Specification for
63. D3139-77	Joints for Plastic Pressure Pipes Using Flexible Elastomeric Seals, Specification for
64. D3140-72(R1977)	Flaring Polyolefin Pipe and Tubing, Recommended Practice for
65. D3197-73	Joints for Plastic Pressure Pipes Using Flexible Elastomeric Seals, Specification for
66. D3212-81	Joints for Drain and Sewer Plastic Pipes Using Flexible Elastomeric Seals, Specification for
67. D3261-82	Butt Heat Fusion Polyethylene (PE) Plastic Fittings for Polyethylene (PE) Plastic Pipe and Tubing, Specification for
68. D3298-81	Perforated Styrene-Rubber (SR) Plastic Drain Pipe, Specification for

Table 84.60-5 (continued)

Standard Reference Number	Title
69. D3309-83	Polybutylene (PB) Plastic Hot-and Cold-Water Distribution Systems, Specification for
70. D3311-82	Drain, Waste, and Vent (DWV) Plastic Fittings Patterns, Specification for
71. D4068-81	Chlorinated Polyethylene (CPE) Sheeting for Concealed Water Containment Membrane, Specification for
72. F402-80	Safe Handling of Solvent Cements and Primers Used for Joining Thermoplastic Pipe and Fittings Practice for
73. F405-82a	Corrugated Polyethylene (PE) Tubing and Fittings, Specification for
74. F409-81	Thermoplastic Accessible and Replaceable Plastic Tube and Tubular Fittings, Specification for
75. F437-82	Threaded Chlorinated Polyvinyl Chloride (CPVC) Plastic Pipe Fittings, Schedule 80, Specification for
76. F438-82	Socket-Type Chlorinated Polyvinyl Chloride (CPVC) Plastic Pipe Fittings, Schedule 40, Specification for
77. F439-82	Socket-Type Chlorinated Polyvinyl Chloride (CPVC) Plastic Pipe Fittings, Schedule 80, Specification for
78. F441-82	Chlorinated Polyvinyl Chloride (CPVC) Plastic Pipe, Schedules 40 and 80, Specification for
79. F442-82	Chlorinated Polyvinyl Chloride (CPVC) Plastic Pipe (SDR-PR), Specification for
80. F443-77	Bell-End Chlorinated Polyvinyl Chloride (CPVC) Pipe, Schedule 40, Specification for
81. F477-76(R1981)	Elastomeric Seals (Gaskets) for Joining Plastic Pipe, Specification for
82. F493-80	Solvent Cements for Chlorinated Polyvinyl Chloride (CPVC) Plastic Pipe and Fittings, Specification for
83. F628-81	Acrylonitrile-Butadiene-Styrene (ABS) Plastic Drain, Waste, and Vent Pipe Having a Foam Core, Specification for
84. F656-80	Primers for Use in Solvent Cement Joints of Poly (Vinyl Chloride)(PVC) Plastic Pipe and Fittings Specification for
85. F845-84	Plastic Insert Fittings for Polybutylene (PB) Tubing, Specification for

Table 84.60-6

AWS	American Welding Society 2501 N.W. 7th Street Miami, Florida 33125
Standard Reference Number	Title
AWS A5.8-81	Brazing Filler Metal, Specification for

Table 84.60-7

AWWA	American Water Works Association Data Processing Department 6666 West Quincy Avenue Denver, Colorado 80235
Standard Reference Number	Title
1. C110/A21.10-82	American National Standard for Ductile-Iron and Gray-Iron Fittings, 3 in. through 48 in., for Water and Other Liquids
2. C111/A21.11-80	American National Standard for Rubber-Gasket Joints for Ductile-Iron and Gray-Iron Pressure Pipe and Fittings
3. C115/A21.15-83	American National Standard for Flanged Ductile-Iron and Gray-Iron Pipe with Threaded Flanges
4. C151/A21.51-81	American National Standard for Ductile-Iron Pipe, Centrifugally Cast in Metal Molds or Sand-Lined Molds, for Water or Other Liquids
5. C153/A21.53-84	American National Standard for Ductile-Iron Compact Fittings, 3 in. through 12 in. for Water and Other Liquids
6. C900-81	American National Standard for Pressure Pipe, 4 in. through 12 in. for Water, Polyvinyl Chloride (PVC)

Table 84.60-8

CISPI

Cast Iron Soil Pipe Institute
1499 Chain Bridge Road, Suite 203
McLean, Virginia 22101

Standard Reference Number	Title
1. 301-82	Cast Iron Soil Pipe and Fittings for Hubless Cast Iron Systems for Drain, Waste or Vent, Sewer, Rainwater or Storm Drain Systems, Specification for
2. 310-82	CISPI's Patented Joints for Use in Connection with Cast Iron Systems for Drain, Waste or Vent, Sewer, Rainwater or Storm Drain Systems, Specification for

Table 84.60-9

FS

Federal Specifications*
National Bureau of Standards
Office of Engineering Standards
U.S. Department of Commerce
Washington, D.C. 20234

*Standards are available from the
Superintendent of Documents, U.S.
Government Printing Office,
Washington, D.C. 20402

Standard Reference Number	Title
WW-P-405a	Corrugated Pipe (Iron or Steel, Zinc Coated), September 1968, with Amendment 1, September 1970

Table 84.60-10

NSF	National Sanitation Foundation 3475 Plymouth Road P.O. Box 1468 Ann Arbor, Michigan 48106
-----	--

Standard Reference Number	Title
Standard 14-85	Plastic Piping Compounds and Related Materials

Table 84.60-11

WQA	Water Quality Association 4151 Naperville Road Lisle, Illinois 60532
-----	--

Standard Reference Number	Title
S-100-85	Household, Commercial and Portable Exchange Water Softeners

SECTION 4. A-84.20 (3) is repealed and recreated to read:

A-84.20 (3) ACCESSIBLE TOILET ROOMS AND SANITARY FACILITIES. The following sketches and diagrams are a reprint from the 1986-1987 edition of the Building and Heating, Ventilating and Air Conditioning, chapters ILHR 50-64. For the current accessibility requirements, contact the Bureau of Buildings and Structures, P.O. Box 7969, Madison, Wisconsin 53707.

EXAMPLES OF ACCESSIBLE TOILET COMPARTMENTS
AS SPECIFIED IN TABLE 52.04-A

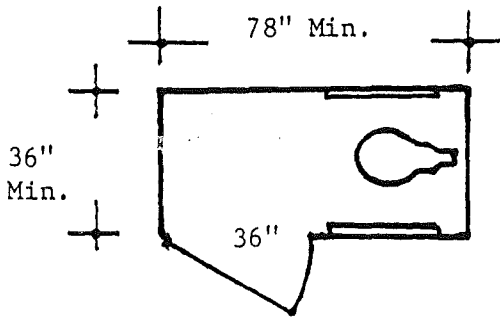

Recommended fixtures:

1. Elongated bowl;
2. Wall mounted.

Note: These are examples of toilet room compartments which are located within accessible toilet rooms.

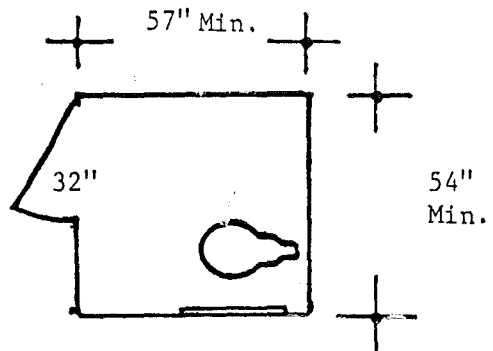
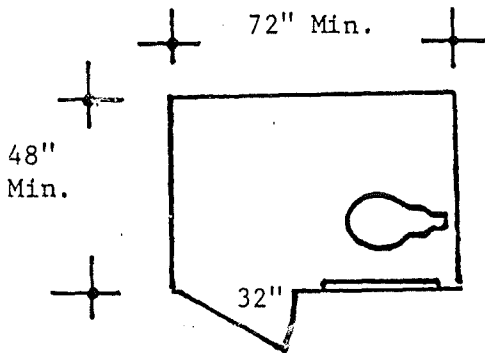
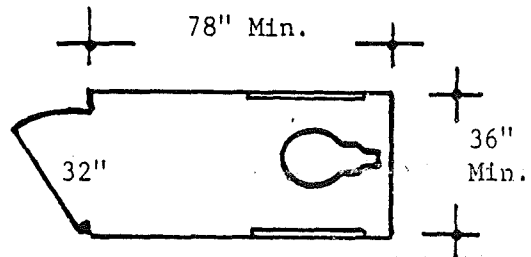
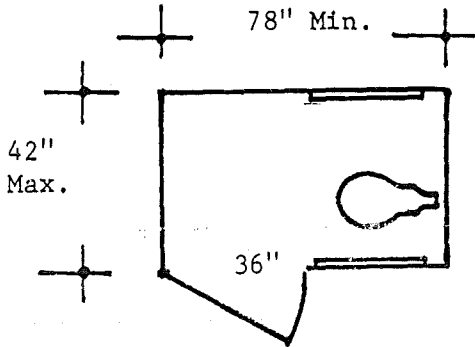

The door of the 54" x 57" water closet compartment having a frontal approach should not align with the placement of the water closet. This compartment configuration if preferred by the physically disabled.

SECTION 5. A84.30 (4) (f) is created to read:

Measuring radius of
a bend in PB pipe or tubing

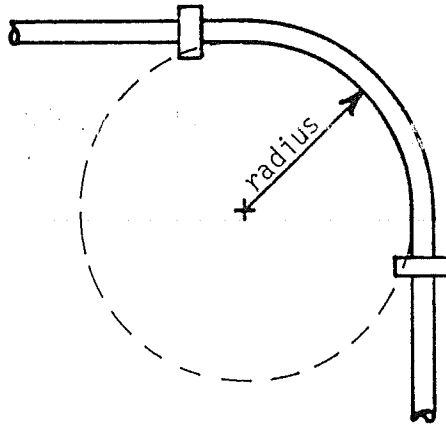

SECTION 6. A-Table 84.30-8 and -9, are created to read:

A-Tables 84.30-8 and -9. ASTM D2774. The following is a reprint of excerpts from ASTM D2774-72(R1978), Recommended Practice for Underground Installation of thermoplastic Pressure Piping.



Designation: D 2774-72 (Reapproved 1978)

An American National Standard

Standard Recommended Practice for UNDERGROUND INSTALLATION OF THERMOPLASTIC PRESSURE PIPING¹

This standard is issued under the fixed designation D 2774; the number immediately following the designation indicates the year of original adoption or, in the case of revision, the year of last revision. A number in parentheses indicates the year of last reapproval. A superscript epsilon (ϵ) indicates an editorial change since the last revision or reapproval.

This method has been approved for use by agencies of the Department of Defense and for listing in the DOD Index of Specification and Standards.

INTRODUCTION

In general, thermoplastic pressure pipe can support earth loads without sustaining excessive stress by mobilizing lateral passive soil forces and internal pressure forces. Thermoplastics have the ability to be deformed without a proportionate increase in stress allowing internal forces to oppose external forces. Proper installation technique ensures that the necessary passive soil pressures at the sides of the pipe will be developed and maintained.

Soils in which trenches are dug should be examined and identified and the trenches prepared and backfilled in accordance with sound bedding practices and this recommendation.

4. Trenching

4.1 *Trench Contour*—The trench bottom should be continuous, relatively smooth, and free of rocks. Where ledge rock, hardpan or boulders are encountered, it is advisable to pad the trench bottom using sand or compacted fine grained soils.

4.2 *Trench Width*—The width of the trench at any point below the top of the pipe should be sufficient to provide adequate room for: (1) joining the pipe in the ditch, if this is required; (2) snaking a pipe from side-to-side along the bottom of the ditch, if recommended by the pipe manufacturers; and (3) filling and com-

 D 2774

compact the side fills. Minimum trench widths may be utilized with most pressure pipe materials by joining the pipe outside the trench and lowering into the trench after adequate joint strength has been obtained.

4.3 *Trench Depth and Pipe Cover*—Soil conditions, pipe size and necessary cover determine trench depth. Sufficient cover must be maintained to keep external stress levels below acceptable design stresses.³ Reliability and safety of service may assume major importance in determining minimum cover for any intended service. Local, state or national codes may also govern. Pipe intended for potable water service should be buried at least 305 mm (12 in.) below maximum expected frost penetration. A minimum cover of 609 mm (24 in.) is considered desirable for pipe subject to heavy overhead traffic. In areas of light overhead traffic a cover of 305 to 457 mm (12 to 18 in.) is usually considered sufficient.

5. General Requirements for Bedding and Backfill

5.1 The pipe should be uniformly and continuously supported over its entire length on firm stable material. Blocking should not be used to change pipe grade or to intermittently support pipe across excavated sections.

5.2 Pipe is installed in a wide range of subsoils. These soils should be not only stable but also applied in such a manner as to physically shield the pipe from damage. Attention should be given to local pipe laying experience which may indicate solutions to particular pipe bedding problems.

5.3 Backfill materials according to the requirements of "Soil Types" (see Appendix X1) with a particle size of 12.7 mm (½ in.) or less should be used to surround the pipe. It should be placed in layers. Each soil layer should be sufficiently compacted to uniformly develop lateral passive soil forces during the backfill operation. It may be advisable to have the pipe under pressure.

5.4 Effects of ground freezing should be considered when pipe is installed at depths subject to frost penetration.

5.5 Vibratory methods are preferred when compacting sand or gravels. Best results are obtained when the soils are in a nearly saturated condition. Where water flooding is used, the initial backfill should be sufficient to ensure

complete coverage of the pipe. Additional material should not be added until the water flooded backfill is firm enough to walk on. Care should be taken to avoid floating the pipe.

5.6 Sand and gravel containing a significant proportion of fine-grained material, such as silt and clay, should be compacted by hand or, preferably, by mechanical tamper.

5.7 The remainder of the backfill should be placed and spread in approximately uniform layers in such a manner as to fill the trench completely so that there will be no unfilled spaces under or about rocks or lumps of earth in the backfill. Large rocks, frozen clods and other debris greater than 76 mm (3 in.) in diameter should be removed. Rolling equipment or heavy tampers should only be used to consolidate the final backfill.

6. Installation Precautions

6.1 Plastic pipe should be stored so as to prevent damage by crushing or piercing. If stored at any length of time, it should be under cover and not in direct sunlight in accordance with the manufacturer's recommendations.

6.2 Care should be taken to protect the pipe from excessive heat or harmful chemicals. Cleaning solutions, detergents, solvents, etc., should be used with caution.

6.3 Pipe may be bent to a minimum radius recommended by the manufacturer for the kind, type, grade, wall thickness, and diameter of a specified pipe. Otherwise changes in direction should be made using suitable fittings.

6.4 Pipe joined using solvent cementing techniques should not be handled or installed in the ditch until after the joints are sufficiently "cured" to prevent weakening the joint.

6.5 During pipe lowering in operations, care should be taken to avoid imposing strains that will overstress or buckle the piping or impose excessive stress on the joints.

6.6 When ditched pipe has been assembled on top of the ditch, it is advisable to cool the pipe to ground temperature before backfilling to prevent pull out due to thermal contraction.

6.7 Suitable anchoring methods should be used to prevent excessive longitudinal or bending movement of the piping.

³ Spangler, M. G., "Secondary Stresses in Buried Pressure Lines." The Iowa State College Bulletin, Engineering Report 23 of the Iowa Engineering Experiment Station, 1954 to 1955.



APPENDIXES

XI. SOIL TYPES

X1.1 A soil is considered stable if it provides dependable support to the pipe and undergoes only slight volume change with variation in its moisture content. The ability of a soil to provide support depends upon its resistance to consolidation and its shear strength. In general, coarse grained soils are considered stable; in the Unified Soil Classification these are defined as soils of which 50 percent or less pass U.S. Standard No. 200 sieve.

NOTE X1—The particle passing through No. 200 sieve is about the smallest size visible to the naked eye.

X1.2 Using the group symbols of the Unified Soil

Classification (Appendix X3) the following are considered stable backfill: GW, GP, GM, GC, SW, SP, provided that maximum particle size is not greater than 12.7 mm (1/2 in.).

X1.3 In terms of over-all use, gravel with fines and sand are the best backfill materials for pressure pipe. Sand or gravel mixed with silts or clays, in which the sand or gravel constitute at least 50 percent of the mixture, are also suitable. Certain soils should not be used as backfill material; these include organic soils, identified by odor or spongy feel, and fat, highly plastic expansive clay. Frozen soil should not be placed in contact with the pipe.

SECTION 7. A-84.40 is created to read:

A-84.40 ASTM F402. The following is a partial reprint of excerpts from ASTM F402-80, Practice for Safe Handling of Solvent Cements and Primers Used for Joining Thermoplastic Pipe and Fittings.



Designation: F 402 - 80

An American National Standard

**Standard Practice for
SAFE HANDLING OF SOLVENT CEMENTS AND PRIMERS
USED FOR JOINING THERMOPLASTIC PIPE AND
FITTINGS¹**

This standard is issued under the fixed designation F 402; the number immediately following the designation indicates the year of original adoption or, in the case of revision, the year of last revision. A number in parentheses indicates the year of last reapproval. A superscript epsilon (ϵ) indicates an editorial change since the last revision or reapproval.

4. Safety

4.1 A number of the solvents contained in primers and solvent cements are classified as airborne contaminants and flammable and combustible liquids. These primers and solvent cements generally are composed of solvent blends which vary with manufacturers. Follow precautions given herein to prevent fire and injury to personnel. Specific safety information on a particular solvent cement or primer may be found in the Material Safety Data supplied by the manufacturer.

 F 402

4.2 Avoid prolonged breathing of solvent vapors. When pipe and fittings are being joined in partially enclosed areas, use a ventilating device in such a manner as to maintain a safe level of vapor concentration with respect to toxicity (1 and 3)³ and flammability (5) in the breathing area. Select ventilating devices and locate them so as not to provide a source of ignition to flammable vapor mixtures.

4.3 Keep solvent cements away from all sources of ignition, heat, sparks, and open flame (5).

4.4 Keep containers for solvent cements and primers tightly closed except when the product is being used. The container type shall be in accordance with Parts 1 to 199, Title 49—Transportation, Code of Federal Regulations. Container labeling shall conform with the requirements of the Federal Hazardous Substance Act as amended.

4.5 Dispose of all rags and other materials used for mopping up spills in a safety waste receptacle. Empty the receptacle daily with proper consideration for the flammable and toxic contents.

4.6 Most of the solvents used in pipe cements

and primers can be considered eye irritants and contact with the eye should be avoided as it may cause eye injury. Proper eye protection and the use of chemical goggles or face shields is advisable where the possibility of splashing exists in handling solvent cements or primers. In case of eye contact, flush with plenty of water for 15 min and call a physician immediately.

4.7 Avoid contact with the skin. Wear proper gloves impervious to and unaffected by the solvents when contact with the skin is likely. Application of the primers or solvent cements with rags and bare hands is not recommended. Brushes and other suitable applicators can be used effectively for applying the solvent cement or primers, thus avoiding skin contact. Dispose of used applicators in the same manner as the rags (see 4.5). In the event of contact, remove contaminated clothing immediately and wash skin with soap and water. Ensure that contaminated clothing is free of flammable and toxic materials before wearing them again.

³ The boldface number in parenthesis refers to the list of references at the end of this practice.

SECTION 8. Ind 69.23 (5) is created to read:

Ind 69.23 (5) PRODUCT APPROVALS AND LISTINGS. (a) Except as provided in par. (b), the fee for the request of a review by the department for a plumbing product under s. ILHR 84.10 (2) shall be determined in accordance with Table 69.23-4.

(b) The fee for the request of the review of a research report by the department for either a cross-connection control device or a water-conserving fixture under the administrative procedures described in s. ILHR 84.10 (2) (a) 1 or 2 shall be \$15.00 per product.

Table 69.23-4

Product	Fee	
	Type of Approval	
	New Approval	Revision or Renewal
1. Chemical or biochemical treatment for private sewage systems	150	75
2. Cross connection control device:		
a. Reduced pressure principle backflow preventer	60	30
b. Backflow preventers with intermediate atmospheric vent	60	30
c. Other cross-connection control device	40	20
3. Health care plumbing appliance	100	50
4. Laboratory plumbing appliance	100	50
5. Prefabricated septic/holding tank	60	30
6. Prefabricated plumbing	150	75
7. Water conserving fixtures:		
a. Faucet	40	20
b. Shower head	30	15
c. Urinal	50	25
d. Urinal flushing device	50	25
e. Water closet	60	30
f. Water closet flushing device	50	25
8. Water treatment device	100	50

(c) The fee for the request to have a plumbing product listed by the department in accordance with s. ILHR 84.10 (2) shall be \$5.00 per product.

(d) The fee for the request of an alternate approval to be issued by the department for a plumbing product shall be \$100.00.

(e) The fee for the request of an experimental approval to be issued by the department for a plumbing product shall be \$200.00.

(f) The fee for a special inspection of an installation of a product for which an experimental approval has been issued in accordance with s. ILHR 84.50 shall be determined in accordance with s. Ind 69.14.

(END)

Puruant to s. 227.22 (2) (intro.), Stats., these rules shall take effect on the first day of the month following publication in the Wisconsin Administrative Register.



State of Wisconsin \ Department of Industry, Labor and Human Relations

Office of the Secretary
201 E. Washington Avenue
P.O. Box 7946
Madison, Wisconsin 53707
Telephone 608/266-7552

March 2, 1988

Gary Poulson
Assistant Revisor of Statutes
Suite 904
30 West Mifflin Street
Madison, Wisconsin 53703

Douglas LaFollette
Secretary of State
Room 271, GEF-1
201 East Washington Avenue
Madison, Wisconsin 53702

Dear Messrs. Poulson and LaFollette:

TRANSMITTAL OF RULE ADOPTION

CLEARINGHOUSE RULE NO. 85-187

RULE NO. Chapter ILHR 84 and Ind 69.23

RELATING TO State Uniform Plumbing Code

Pursuant to section 227.20, Stats., agencies are required to file a certified copy of every rule adopted by the agency with the offices of the Secretary of State and the Revisor of Statutes.

At this time, the following material is being submitted to you:

1. Order of Adoption.
2. Rules Certificate Form.
3. Rules in Final Draft Form.

Pursuant to section 227.114, Stats., a summary of the final regulatory flexibility analysis is also included.

Respectfully submitted,

John T. Coughlin
Secretary