

# RULES CERTIFICATE

STATE OF WISCONSIN )  
 ) SS  
DEPT. OF INDUSTRY, )  
LABOR & HUMAN RELATIONS)

TO ALL TO WHOM THESE PRESENTS SHALL COME, GREETINGS:

I, Carol Skornicka, Secretary of the Department of Industry, Labor and Human Relations, and custodian of the official records of said department, do hereby certify that the annexed rule(s) relating to Flammable and Combustible Liquids Code and Associated Fees were duly approved and adopted by this department on January 24, 1991.

I further certify that said copy has been compared by me with the original on file in this department and that the same is a true copy thereof, and of the whole of such original.

IN TESTIMONY WHEREOF, I have hereunto set my hand and affixed the official seal of the department at 9:00 a.m. in the city of Madison, this 24th day of January A.D. 19 91.

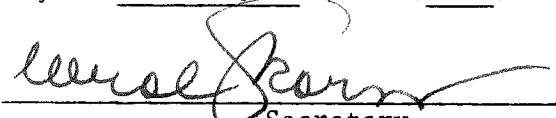
  
Secretary

**RECEIVED**

JAN 24 1991  
2:10 pm  
Revisor of Statutes  
Bureau

# ORDER OF ADOPTION

Pursuant to authority vested in the Department of Industry, Labor and Human Relations by section(s) 101.02 (1), 101.02 (15)(h) to (j), 101.09 (3),  
~~101.14 (1) (a) and 101.19 (1)(a), (b), (d) and (g)~~,  
Stats., the Department of Industry, Labor and Human Relations  creates;

amends;  repeals and recreates;  repeals and adopts rules of Wisconsin  
Administrative Code chapter (s):

|                           |   |
|---------------------------|---|
| <u>ILHR 10 and Ind 69</u> | <u>Flammable and Combustible Liquids Code and</u> |
| (Number)                  | Associated Fees (Title)                           |

The attached rules shall take effect on the first day of the month following  
publication in the Wisconsin Administrative Register pursuant to section  
227.22, Stats.

Adopted at Madison, Wisconsin, this

date: January 24, 1991

DEPARTMENT OF INDUSTRY, LABOR AND HUMAN  
RELATIONS



Secretary

**RECEIVED**

JAN 24 1991

Revisor of Statutes  
Bureau

1947

1948

1949



State of Wisconsin

Department of Industry, Labor and Human Relations

# RULES in FINAL DRAFT FORM

CR 90-80

**RECEIVED**

JAN 24 1991

Revisor of Statutes  
Bureau

**Rule:** Chs. ILHR 10 and Ind 69

**Relating to:** Flammable and Combustible Liquids Code and

Associated Fees





The Wisconsin Department of Industry, Labor and Human Relations proposes an order to repeal ch. Ind 8; to repeal and recreate s. Ind 69.10 (1) and Table 69.10; and to create ch. ILHR 10 relating to Flammable and Combustible Liquids, including the protection of groundwater.

\* \* \* \* \*

Analysis of Rules

Statutory Authority: ss. 101.02 (1), 101.02 (15)(h) to (j), 101.09 (3), 101.14 (1)(a), and 101.19 (1)(a), (b), (d) and (g), Stats.

Statutes Interpreted: ss. 101.02 (15)(h) to (j), 101.09 (3), 101.14 (1)(a), and 101.19 (1)(a), (b), (d) and (g), Stats.

The Wisconsin Administrative Flammable and Combustible Liquids Code, Chapter Ind 8, is proposed to be revised and renumbered Chapter ILHR 10. Chapter Ind 8 has been in effect since October 18, 1931. The department has updated the code on a regular basis over the years to keep it current with national standards and industry developments. Originally, the major purpose of the code was fire prevention and protection as it relates to flammable and combustible liquids. The current 1982 edition of the code, however, includes provisions for groundwater protection.

Currently, under ch. Ind 8, the department regulates a broad scope of flammable and combustible liquid storage, handling and dispensing facilities, including aboveground and underground tanks at commercial and industrial plants, bulk plants, service stations, processing plants, refineries, chemical plants, distilleries, farms, construction projects, and tanks serving oil burning equipment.

The groundwater protection provisions of ch. Ind 8 include standards for the design and proper installation of UST systems, the installation of collection sumps, corrosion protection requirements for underground tanks and piping, and inventory reconciliation requirements for service stations.

In 1985, the Wisconsin Legislature passed 1983 Wisconsin Act 410 that mandates the department to promulgate rules for aboveground storage tanks of 5,000 gallons and greater capacity and all underground storage tanks for the purpose of protecting the waters of the state from harm due to contamination by flammable and combustible liquids. The department intends to fulfill this mandate, in part, by incorporating the Groundwater Protection Regulations of the USEPA as published on September 23 and October 26, 1988. The EPA rules were adopted into the DILHR code draft with only minor modifications so that those tanks in Wisconsin which are included under the federal regulations will be subject to the same level of regulation as tanks in other states.

The scope of the EPA groundwater protection regulations does not include certain types of tanks, such as aboveground tanks, farm and residential motor fuel USTs of 1,100 gallons and under, and heating oil USTs, that are included under Wisconsin Act 410. The proposed rules include an update of the groundwater protection provisions of Ind 8 to address those tanks that are not regulated under the federal program.

The basis for the fire safety provisions of Ind 8 was the 1981 edition of the National Fire Protection Association (NFPA) standard 30. The fire safety provisions of the proposed rules are based on the 1987 edition of the NFPA standard.

The proposed rules contained in ch. ILHR 10 were developed in conjunction with the Flammable and Combustible Liquids Subcommittee of the Wisconsin Fire Prevention Council. The membership of the subcommittee is given at the end of this analysis.

### SUBCHAPTER I - PURPOSE AND APPLICATION

One of the major purposes of the Flammable and Combustible Liquids Code is fire protection and prevention as it relates to the storage, handling and use of flammable and combustible liquids. Groundwater protection standards are a relatively new addition to the code. The rules address all facets of the safe installation, operation, use, maintenance and transportation of flammable and combustible liquids.

Under the EPA regulations, "regulated substances" are substances defined in section 101 (14) of CERCLA, with the exemption of hazardous wastes, and all liquid petroleum products. In ILHR 10, the definition of "regulated substances" is based on Wisconsin Act 410. Under ILHR 10, regulated substances are flammable and combustible liquids, or liquids with a flashpoint below 200°F.

### SUBCHAPTER II - DEFINITIONS

Most definitions were taken from the existing Ind 8, USEPA regulations and other national standards. Other definitions were developed by the subcommittee to meet specific needs.

### SUBCHAPTER III - ADMINISTRATION AND ENFORCEMENT

The primary enforcement mechanisms for the proposed code include tank registration, tank use permitting, plan review, onsite inspections and miscellaneous administration enforcement procedures. The department hopes to have most onsite inspection responsibilities performed by local fire departments having jurisdiction. In response to the increased workload, the department will forward funding to the local fire department or authorized agent which inspects the underground storage tank. The amount of this funding will be based on the number of permits issued and will help offset the associated costs of local inspection and enforcement services. The department

will be responsible for conducting inspections in those areas where local fire departments or other government organizations elect not to have the enforcement responsibility.

The proposed rules also mandate plan examination of all new or replacement flammable and combustible liquids storage tank facilities at either the state or local level. Installations of 5,000 gallons or larger capacity are required to be submitted to the state for review and approval. Installations under 5000 gallons are submitted to the local fire department or authorized agent for review and approval. Those who enforce the groundwater protection related provisions of the code will be required to be certified by the department. Appropriate fees to offset the program costs for plan review have been included in the proposal. A minimum fee for local plan review has also been included, but an option for the local unit of government to establish higher fees is included.

Manufacturers of leak detection devices, flex connectors, and dike liners will be required to obtain written approvals for their products from the department. This approval system may also be used on a voluntary basis by manufacturers of other types of products to reduce or eliminate repeated submittals of documentation to verify code compliance with each project. Once an approval number is obtained for a product, that number may be submitted with plans for projects in which that product is used as proof of compliance.

Specific product approvals are mandatory only for leak detection devices, flex connectors, and dike liners. Due to the technical complexity of these products and the importance of their roles in groundwater protection, it was decided that review should be at the department level.

The federal regulations and state law require the department to establish an inventory of underground storage tanks. For that purpose, an underground storage tank registration and permitting program has been proposed in the rules. The owners of all new or replacement underground storage tanks will have to register the tanks with the department. The owners of existing underground storage tanks will all have to register their tanks. Aboveground tanks which are eligible for reimbursement under the Petroleum Environmental Clean-up Fund Act (PECFA) are also required to be registered.

Under the permit program, owners of federally regulated underground tanks identified in Subch. VI must receive a use permit for the tank. The use permit will be good for a period of 3 years and will have to be renewed for continued use and operation of the tank.

Under ILHR 10, enforcement tools are expanded with regard to tank systems which are found to be or are suspected of releasing product. Authority is given to enforcers of the rules to shut down systems in 3 cases:

Immediate shut down when there is an immediate danger to life, safety or health (i.e., visual evidence of leakage, human exposure, product in drinking water, vapors in buildings);

Delayed shut down occurs if there is clear and present evidence of a release to the environment (i.e., unreconciled inventory records, test results which indicate a leak);

Delayed shut down may occur where there is a continuing code violation which goes unresolved after the issuance of two orders and subsequent inspections, unless an appeal has been filed by the owner in response to the orders.

#### SUBCHAPTER IV - STANDARDS

The department has decided to adopt the national standards by reference rather than reprint the text of those standards in the code. The provisions for fire protection and prevention in the code include the adoption of the National Fire Protection Association Standard NFPA 30 - Flammable and Combustible Liquids and the new NFPA Standard 30A - Automotive and Marine Service Stations. In addition, a series of secondary NFPA standards as well as ASTM and other national standards have been adopted by reference.

For the groundwater protection provisions of the code, primary and secondary standards used in the federal regulations are adopted by reference. The proposed rules adopt the most current editions of these standards that are available.

The National Fire Protection Association recently adopted new 1990 Editions of NFPA Standards 30, 30A and a new NFPA Standard 30B. The adoption of these standards took place after the public hearings. Rather than delay the implementation of the groundwater protection standards of ILHR 10, the department intends to promulgate the rules as they are currently written with the incorporation of the 1987 edition of the NFPA standards. The department intends to begin a separate rulemaking process to review and consider the 1990 editions of the NFPA standards for incorporation after the adoption of this set of rules.

#### SUBCHAPTER V - GENERAL REQUIREMENTS FOR FIRE PREVENTION AND PROTECTION

This subchapter contains miscellaneous, Wisconsin specific provisions many of which were contained in Ind 8 but are not addressed in EPA or other national standards.

Under the Wisconsin Administrative Building Code, chs. ILHR 50 to 64, waste oil burners are allowed to be installed in garages. Due to the possible contamination of crankcase oil with Class I liquids, Ind 8 required the waste oil tank to be located outside the buildings. Manufacturers of waste oil heaters have requested that the department allow these waste oil tanks to be stored indoors for the ease of operation of their heaters in cold weather.

In response to the hearing testimony presented by waste oil heater manufacturers, ILHR 10 contains an exception to allow used internal combustion engine crankcase oil to be handled as a Class II or III liquid, if testing confirms a flash point above 100°F. Each batch of waste oil will be required to be tested in accordance with closed cup test methods before it is used to fill the indoor tank of a waste oil heater.

Also, the provisions for indoor storage of used internal combustion engine crankcase oil currently used in many quick-oil change type garages is proposed to be adopted in the code. Provisions include rated enclosures, building fire detection systems, and fire suppression systems in the tank enclosure. Crankcase oil tanks of up to 300 gallons will be allowed to be unenclosed if the tanks are designed for use with Class I liquids.

In response to the mandate of Wisconsin Act 410, the dike design specifications of ILHR 10 contain provisions for groundwater protection that are not found in the NFPA 30 standard. Existing tanks which exceed 5,000 gallons capacity are required to be retrofitted with a diking system which has the floor, sidewalls and undertank area impervious to stored product or must be retrofitted with secondary containment or leak detection or lining at the bottom of the tank within 10 years of the effective date of the rules.

The dispensing of kerosene will be prohibited on multiple nozzle dispensing equipment which also dispenses Class I liquids. Existing equipment is to comply within 5 years. In new installations, kerosene dispensing equipment is required to be placed 10 feet away from Class I liquid dispensers. Diesel nozzles are required to be color coded yellow.

ILHR 10 will allow vehicle fueling from aboveground tanks at more types of service stations than currently allowed by NFPA 30, including retail service stations. (Included: retail service stations, private fleet service stations, registered airports, marinas, and residential marine stations. Not included: tanks on residential property.) The proposal requires secondary containment, establishes setbacks and limits the tank size to 10,000 gallons per tank and 30,000 gallons per station, and 560 gallons for residential marine facilities.

| AGGREGATE CAPACITY      | SETBACK  |
|-------------------------|----------|
| 100 - 2,000 gallons     | 25 feet  |
| 2,001 - 10,000 gallons  | 50 feet  |
| 10,001 - 20,000 gallons | 75 feet  |
| 20,001 - 30,000 gallons | 100 feet |

Setbacks may be reduced if fire-resistive materials are provided to protect the tank. The setback between dispensers and tanks is 30 feet at retail facilities.

Aboveground heating oil tanks will continue to be regulated in accordance with standards adapted from NFPA 31 and reprinted in ch. ILHR 10.

#### SUBCHAPTER VI - GENERAL REQUIREMENTS FOR GROUNDWATER PROTECTION

(The scope of this subchapter includes federally regulated underground tanks, that is, all underground tanks except farm and residential tanks of 1,100 gallons or less capacity used for storing motor fuel for noncommercial purposes and underground tanks for heating oil for consumptive use on the premises where stored.)

In early 1987, the U.S. Environmental Protection Agency announced its intentions to publish federal groundwater protection rules developed in response to the Resource Conservation and Recovery Act. The federal law establishes the Environmental Protection Agency regulations as the minimum nationwide regulations. Therefore, all state regulations and programs must be at least as stringent as the federal regulations.

The final USEPA regulations were published in the September 23 and October 26, 1988, Federal Registers. Due to the pre-emptive nature of the federal law, the USEPA regulations have been incorporated into this subchapter of the proposed draft of ILHR 10 and are intended to apply to those tanks included within the scope of the federal program.

The USEPA regulations include a rule which establishes a "tank life" for existing tanks. Existing tanks are basically given a 10-year "life" from December 22, 1988. At the end of that time period, December 22, 1998, the tanks must either be removed from the ground, abandoned in place or retrofitted to current standards.

The USEPA regulations also include responsibilities of tank owners regarding leaking tanks and persons responsible for spillages of flammable and combustible liquids or overfilling of tanks. Section 144.76, Stats., gives the authority to the Department of Natural Resources (DNR), not DILHR, to administer and enforce rules relating to corrective actions in response to releases of regulated substances. Chapter ILHR 10 references administrative procedures that the DNR will use in the event of such occurrences.

A summary of the major provisions made to modify the federal regulations follows.

Tanks of airport hydrant systems and tanks for emergency power generators are no longer deferred.

USTs of 110 gallons or less capacity are not exempted to be consistent with Wisconsin Statute which does not specify a minimum tank size. Similarly, tanks with 'de minimus' concentrations of regulated substances are not exempted.

Previously used tanks which have been upgraded and certified by the manufacturer will be allowed to be used in accordance with the certification.

Release detection methods will be required to detect a release from any portion of the tank which would contain product if the tank were 95% full.

Manufacturers of leak detection methods will be required to specify the threshold test result obtained with their test method that would indicate that a leak has occurred.

Design standards for groundwater and vapor monitoring wells for release detection are more specific.

Release reporting requirements are not included in this chapter as the DNR will be enforcing the release reporting requirements.

Language is added to differentiate between tanks which are abandoned and subject to closure and those which are simply seldom used. In order to be in use, vehicle fuel tanks must have transfers made to or from them at least once in any 90-day period and heating oil tanks must have transfers made at least once in any 6-month period. Use with fewer transfers may also be approved by the department. Tanks for emergency generators are excluded from closure.

Tanks which are abandoned after the effective date of the requirements would be allowed to be abandoned in place only if the structural integrity of a building would be affected or if a DILHR authorized agent determines conditions of hardship to exist, all other tanks are required to be removed.

Tanks are required to be made inert prior to removal from the ground.

Site assessments will be required for tanks which are relined if holes or rust plugs are found in the tank during the relining process.

Site assessment requirements will be augmented by procedures developed in conjunction with the Department of Natural Resources specified in Appendix B of the code.

#### SUBCHAPTER VII - GROUNDWATER PROTECTION FOR SMALL FARM AND RESIDENTIAL MOTOR FUEL USTS AND HEATING OIL USTS

(This subchapter covers underground tanks not federally regulated: farm and residential underground tanks of 1100 gallons or less capacity used for storage of motor fuel for noncommercial purposes and underground tanks for heating oil for consumptive use on the premises where stored.)

The scope of 1983 Wisconsin Act 410 goes beyond that of the federal groundwater protection law. The department has proposed an update of the current groundwater regulations for those underground tanks which are excluded from the federal program but included under the state groundwater protection law. The requirements for those underground tanks can be found in this subchapter of the proposed draft.

The following provisions were developed in conjunction with the subcommittee:

New tanks under this subchapter are required to be designed and installed in accordance with the federal requirements except that spill protection is not required for heating oil underground storage tank systems of less than or equal to 4,000 gallons, and overflow protection for heating oil tanks may be provided via use of a vent whistle.

Existing farm and residential motor fuel underground storage tank systems and heating oil underground storage tank systems of more than 4000 gallons are required to be upgraded to include cathodic protection or relined within 10 years of the effective date of the proposed rules.

Existing heating oil USTs will be required to one of the following:

Beginning 10 years after the effective date of the code, heating oil USTs of 4,000 gallon or less capacity must be tested for leaks at least once every two years. A tank tightness testing method approved by DILHR must be used or;



Heating oil UST's of 4,000 gallon or less capacity must comply with ILHR 10.52(1)(a), (b), or (c) requirements to upgrade or abandon the system within 15 years of the effective date of the code.

New heating oil USTs will be required to be provided with release detection upon installation. New and existing heating oil USTs of more than 4,000 gallons are required to be provided with the same release detection equipment as specified under the federal regulations.

General operating requirements of the federal rules also apply to all tanks under this subchapter.

Release reporting and investigation requirements for tanks under this subchapter are the same as for federally regulated tanks.

Corrective actions for tanks under this subchapter are the same as for federally regulated tanks.

Closure requirements are the same as for federally regulated tanks except that site assessments are only required for heating oil tanks more than 4,000 gallons.

#### SUBCHAPTER VIII - FINANCIAL RESPONSIBILITY

The federal law currently requires owners or operators of UST systems to be able to pay for the costs of third party liability and corrective action caused by releases from their tanks. These costs could include cleaning up leaked petroleum, correcting environmental damage, supplying drinking water, and compensating for personal injury or property damage. This subchapter of ILHR 10 adopts the USEPA financial responsibility provisions. Because state regulations must be at least as stringent as the USEPA rules, ch. ILHR 10 includes the same dollar amounts and effective dates as the USEPA rules.

#### SUBCHAPTER IX - QUALIFICATIONS, TESTING PROCEDURES AND DUTIES OF CERTIFIED PERSONS

Under the proposed rules, persons who install, remove, reline, clean, inspect, or perform tightness testing on underground storage tank systems, or perform site assessments will be required to be certified by the department as qualified to perform these functions. This subchapter describes the testing and certification process, the procedures for revoking certification and the duties of certified persons.

Under the proposed subchapter, the persons responsible for onsite supervision of underground storage tank installation, removal, tightness testing or site assessment are required to be certified. The certified supervisor is required to be onsite at specified milestones for the activity. The milestones were based on major points identified in national or industry standards for the various activities.

Companies involved in carrying out activities which require certification must be registered with the department as well. A registration may be revoked in the same manner as a certification.

Flammable and Combustible Liquids Subcommittee Membership

The membership of the Flammable and Combustible Liquids Subcommittee of the Fire Prevention Council which advised the department in the development of ch. ILHR 10 is given below. The subcommittee has endorsed the proposed rules for public hearing consideration.

|                   |  |
|-------------------|--|
| Tom Bergamini     | Department of Natural Resources                        |
| Bennette Burks    | Department of Industry Labor and Human Relations       |
| Tom Coenen        | Wisconsin Retail Gas Dealers Association               |
| Bill Davis        | Wisconsin Environmental Decade                         |
| Charles Elliott   | Wisconsin Petroleum Council                            |
| Ted Frostman      | Consulting Environmental Engineers                     |
| Charles Hawk      | Wisconsin Association of Manufacturing<br>and Commerce |
| Clyde Hutchinson  | City of Milwaukee                                      |
| Tom Johnson       | Wisconsin Electric Power Company                       |
| Ken Kirn          | Agricultural Cooperatives/<br>Agricultural tank Owners |
| James Lang        | Chairman, Wisconsin PECFA Council                      |
| Phil McManus      | Petroleum Marketing Association of Wisconsin           |
| William Morrissey | Department of Industry, Labor and Human Relations      |
| William Rausch    | Wisconsin State Fire Chiefs Association                |
| Frank Reisenauer  | National Leak Prevention Association                   |
| Patrick Ryan      | Petroleum Equipment/Tank Installers                    |
| Robert Vajgrt     | Wisconsin Fire Inspectors Association                  |
| Pat Wall          | Petroleum Marketing Association of Wisconsin           |

\* \* \* \* \*



CHAPTER ILHR 10  
FLAMMABLE AND COMBUSTIBLE LIQUIDS

SUBCHAPTER I - PURPOSE AND APPLICATION

- ILHR 10.001 Purpose
- 10.002 Application

SUBCHAPTER II - DEFINITIONS

- ILHR 10.01 Definitions

SUBCHAPTER III - ADMINISTRATION AND ENFORCEMENT

- ILHR 10.10 Approval of Proposed Construction, Installation or Operation
- 10.105 Plan Revision
- 10.11 Revocation of Approval
- 10.12 Department Limitation and Expiration of Plan Approval
- 10.125 Specific Approval of Materials, Equipment and Devices
- 10.13 Registration - New and Replacement Aboveground and Underground Storage Tanks
- 10.14 Registration - Existing Aboveground and Underground Storage Tanks
- 10.15 Registration - Permanently Closed or Removed Aboveground and Underground Storage Tanks
- 10.16 New and Replacement Underground Storage Tank Use Permit
- 10.17 Existing Underground Storage Tank Use Permit
- 10.18 Enforcement and Inspections
- 10.19 Groundwater Protection Inspections
- 10.20 Fees
- 10.21 Appeals
- 10.22 Petition for Variance
- 10.23 Penalties

SUBCHAPTER IV - STANDARDS

- ILHR 10.25 Adoption of Standards by Reference
- 10.26 Secondary References
- 10.27 Construction, Installation, Operation and Maintenance of Flammable and Combustible Liquid Facilities

SUBCHAPTER V - GENERAL REQUIREMENTS FOR FIRE PREVENTION AND PROTECTION

PART 1 - MISCELLANEOUS APPLICATIONS

- ILHR 10.28 General Provisions for Sale, Purchase, Dispensing or Use of Flammable and Combustible Liquids
- 10.29 Race Track Fueling Stations
- 10.30 Motor Vehicle Exhibition

- 10.31 Fueling of Motor Vehicles
- 10.32 Vehicle-Mounted Contractor Tanks and Vehicle-Mounted Farm Fuel Tanks
- 10.33 Waste Oil Collection Points
- 10.335 Used Internal Combustion Engine Crankcase Oil

#### PART 2 - TANK STORAGE

- 10.34 Tanks Used as Pressure Vessels
- 10.342 Location of New and Replacement Underground Storage Tanks
- 10.345 Impounding Around Outside Aboveground Storage Tanks by Diking
- 10.35 Aboveground Tank Labels
- 10.355 Aboveground Tank Design
- 10.36 Closure of Aboveground Storage Tanks

#### PART 3 - BULK PLANTS AND TERMINALS

- 10.37 Lesser Clearances at Existing Bulk Plants Permitted
- 10.38 Bulk Plant Product Color Coding
- 10.39 Care and Attendance of Property

#### PART 4 - SERVICE STATIONS

- 10.395 Overfill Protection for Aboveground Storage Tanks
- 10.40 Separation and Color Coding of Dispensing Equipment
- 10.41 Service Station Product Color Coding
- 10.415 Vehicle Fuel Dispensing from Aboveground Tanks
- 10.42 Fuel Dispensing for Marine Craft

#### PART 5 - FARMS AND CONSTRUCTION PROJECTS

- 10.43 Application
- 10.44 General Requirements for Tank Storage
- 10.445 Individual Containers of 60 Gallons or Less Capacity Each
- 10.45 Aboveground Tanks of 61 to 1100 Gallons Capacity Each
- 10.455 Aboveground Tanks on Farms Exceeding 1100 Gallons Individual Capacity
- 10.46 Marking of Tanks and Containers

#### PART 6 - OIL BURNING

- 10.47 Use of Approved Equipment
- 10.471 Oil Storage and Supply Systems
- 10.472 Design and Construction of Aboveground Tanks
- 10.473 Installation of Unenclosed Tanks Inside Buildings
- 10.474 Installation of Enclosed Supply Tanks Inside Buildings
- 10.475 Installation of Outside Aboveground Tanks Not Larger Than 660 Gallons
- 10.476 Installation of Outside Aboveground Tanks Larger Than 660 Gallons
- 10.477 Location of Outside Aboveground Tanks
- 10.478 Control of Release from Aboveground Tanks

- 10.479 Venting for Aboveground Tanks
- 10.48 Supports Foundations and Anchorage
- 10.481 Testing
- 10.482 Piping Materials and Design for Aboveground Tanks
- 10.483 Fill and Return Piping
- 10.484 Supply Connections
- 10.485 Vent Piping
- 10.486 Pressurized Tank Feed
- 10.487 Oil Gaging
- 10.488 Centralized Oil Distribution Systems
- 10.489 Oil Distribution Systems for Roof-Mounted or Ceiling Suspended Oil-Fired Units
- 10.49 Tests of Piping

SUBCHAPTER VI - GENERAL REQUIREMENTS  
FOR GROUNDWATER PROTECTION

(All Underground Storage Tanks Except Farm and Residential Tanks of 1100 Gallons or Less Capacity Used for Storing Motor Fuel for Noncommercial Purposes and Underground Storage Tanks Used for Storing Heating Oil for Consumptive Use on the Premises Where Stored)

PART 1 - PROGRAM SCOPE AND INTERIM PROHIBITION

- ILHR 10.50 Applicability
- 10.505 Interim Prohibition for Deferred UST Systems

PART 2 - UST SYSTEMS: DESIGN, CONSTRUCTION, INSTALLATION AND NOTIFICATION

- ILHR 10.51 Performance Standards for UST Systems Installed After December 22, 1988
- 10.52 Upgrading of Existing UST Systems

PART 3 - GENERAL OPERATING REQUIREMENTS

- ILHR 10.54 Spill and Overfill Control
- 10.55 Operation and Maintenance of Corrosion Protection
- 10.56 Compatibility
- 10.57 Repairs Allowed
- 10.58 Reporting and Recordkeeping

PART 4 - RELEASE DETECTION

- ILHR 10.59 General Requirements for All UST Systems
- 10.60 Requirements for Petroleum UST Systems
- 10.605 Requirements for Hazardous Substance UST Systems
- 10.61 Methods of Release Detection for Tanks

- 10.615 Methods of Release Detection for Piping
- 10.625 Release Detection Recordkeeping

PART 5 - SUSPECTED RELEASE INVESTIGATION AND CONFIRMATION

- ILHR 10.63 Conditions Indicating Suspected Releases
- 10.635 Confirming Suspected Releases
- 10.64 Release Confirmation and Reporting

PART 6 - EMERGENCY RELEASE RESPONSE

- ILHR 10.66 Emergency Release Response and Abatement Measures
- 10.67 Investigation and Corrective Action

PART 7 - OUT-OF-SERVICE UST SYSTEMS, CLOSURE, AND SITE ASSESSMENT

- ILHR 10.73 Temporary Closure
- 10.731 Seldom Used Tanks
- 10.732 Permanent Closure and Changes-in-Service
- 10.734 Site Assessment
- 10.736 Applicability to Previously Closed UST Systems
- 10.738 Closure Records

SUBCHAPTER VII - GROUNDWATER PROTECTION FOR SMALL FARM  
AND RESIDENTIAL MOTOR FUEL USTs AND FOR HEATING OIL USTs

(Farm and Residential Underground Storage  
Tanks of 1100 Gallons or Less Capacity Used For  
Storing Motor Fuel for Noncommercial Purposes;  
Underground Storage Tanks for Storing Heating Oil for  
Consumptive Purposes on the Premises Where Stored.)

PART 1 - PROGRAM SCOPE

- ILHR 10.74 Scope

PART 2 -NOTIFICATION AND REGISTRATION

- ILHR 10.75 New and Replacement Storage Tank System Registration
- 10.76 Existing Storage Tank System Registration

PART 3 - UST SYSTEM DESIGN, CONSTRUCTION, INSTALLATION,  
RELEASE DETECTION, MAINTENANCE AND REPAIR

- ILHR 10.77 Performance Standards for New UST Systems
- 10.771 Upgrading of Existing UST Systems
- 10.772 General Operating Requirements
- 10.773 Release Detection for Heating Oil UST Systems of More Than  
4000 Gallons Capacity

PART 4 - SUSPECTED RELEASE INVESTIGATION AND CONFIRMATION

ILHR 10.78 General

PART 5 - EMERGENCY RELEASE RESPONSE

ILHR 10.79 General

PART 6 - OUT-OF-SERVICE STORAGE TANK SYSTEMS,  
CLOSURE, AND SITE ASSESSMENT

ILHR 10.80 Temporary and Permanent Closure and Change-in-Service  
10.805 Site Assessment

SUBCHAPTER VIII - FINANCIAL RESPONSIBILITY

ILHR 10.81 Applicability  
10.812 Compliance Dates  
10.814 Definition of Terms  
10.816 Amount and Scope of Required Financial Responsibility  
10.818 Allowable Mechanisms and Combinations of Mechanisms  
10.82 Financial Test of Self-Insurance  
10.822 Guarantee  
10.824 Insurance and Risk Retention Group Coverage  
10.826 Surety Bond  
10.828 Letter of Credit  
10.834 Trust Fund  
10.836 Standby Trust Fund  
10.838 Substitution of Financial Assurance Mechanisms by Owner or  
Operator  
10.84 Cancellation or Nonrenewal by a Provider of Financial Assurance  
10.842 Reporting by Owner or Operator  
10.844 Recordkeeping  
10.846 Drawing on Financial Assurance Mechanisms  
10.848 Release from the Requirements  
10.85 Bankruptcy or Other Incapacity of Owner or Operator or  
Provider of Financial Assurance  
10.852 Replenishment of Guarantees, Letters of Credit, or Surety Bonds

SUBCHAPTER IX - QUALIFICATIONS, TESTING PROCEDURES AND DUTIES FOR  
CERTIFIED PERSONS

PART 1 - APPLICATION

ILHR 10.91 General

PART 2 - PROCEDURES FOR CERTIFICATION OR REGISTRATION

ILHR 10.912 Eligibility for Certification  
10.914 Application for Certification or Recertification



- 10.916 Examination
- 10.918 Issuance of Certificate
- 10.92 Renewal of Certificate
- 10.922 Denial of Certification
- 10.923 Registration of Companies
- 10.9235 Certification Advisory Board

PART 3 - DUTIES OF CERTIFIED PERSONS

- ILHR 10.924 Supervision
- ILHR 10.9245 Conflict of Interest

PART 4 - SUSPENSION AND REVOCATION

- ILHR 10.925 Suspension or Revocation of Certification or Registration

PART 5 - PROCEDURES

- ILHR 10.926 Filing of Complaint
- 10.928 Investigation and Notification
- 10.93 Mailing
- 10.932 Response
- 10.934 Conciliation Agreement Prior to Hearing
- 10.936 Hearings
- 10.938 Findings
- 10.94 Appeal Arguments
- 10.942 Petition for Rules or Declaratory Rulings

APPENDIX A

APPENDIX B

SECTION 1. Chapter ILHR 10 is created to read:

Chapter ILHR 10  
FLAMMABLE AND COMBUSTIBLE LIQUIDS

SUBCHAPTER 1 - PURPOSE AND APPLICATION

ILHR 10.001 PURPOSE. (1) The purpose of this chapter is to provide for safe storage, installation, operation, use, maintenance and transportation of flammable and combustible liquids.

(2) (a) Pursuant to s. 101.09 (3), Stats., as created by 1983 Wisconsin Act 410, the purpose of this chapter is as follows: "...protecting the waters of the state from harm due to contamination by flammable and combustible liquids. The rule shall comply with ch. 160. The rule may include different standards for new and existing tanks, but all standards shall provide substantially similar protection for the waters of the state. The rule shall include maintenance requirements related to detection and prevention of leaks."

Note: The locations and phone numbers of district offices of the Bureau of Petroleum Inspection and Fire Protection, DILHR, and DNR field districts and areas may be obtained by contacting DILHR the Bureau of Petroleum Inspection and Fire Protection, P.O. Box 7969, Madison, Wisconsin 53707.

(b) The rules of this chapter are intended to comply with the flammable and combustible liquid related provisions of Subtitle I of the Hazardous and Solid Waste Amendments of 1984, Public Law 98-616 which extended and strengthened the provisions of the Solid Waste Disposal Act as amended by the Resource Conservation and Recovery Act (RCRA) of 1976 [42 U.S.C. 6912, 6991 (a) to 6991 (h)].

ILHR 10.002 APPLICATION. (1) NEW FACILITIES AND STRUCTURES. The provisions of this chapter shall apply to all new facilities and structures involving flammable and combustible liquids, and also to additions to existing facilities and structures involving flammable and combustible liquids.

(2) ALTERATIONS TO FACILITIES AND STRUCTURES. (a) The provisions of this chapter shall apply to remodeling or alterations in any flammable and combustible liquid facility or structure which is integral to the flammable and combustible liquid storage or dispensing including those which affect fire hazard or replacement of major equipment.

(b) The provisions of this chapter do not apply to general maintenance of any flammable and combustible liquid facility or structure.

(3) CHANGE IN OPERATION. If the operation of an existing facility or structure is changed to an operation regulated by this chapter, the facility or structure shall be made to comply with the requirements for the new operation as provided in this chapter.

(4) GROUNDWATER PROTECTION PROVISIONS. Pursuant to s. 101.09, Stats., each groundwater protection provision of this chapter shall apply, as specified in that provision, to all flammable and combustible liquid facilities and structures in existence on the effective date of this section, even if the flammable and combustible liquid facility or structure is not undergoing remodeling, alteration or change of operation.

Note: See ss. ILHR 10.13 to 10.17 and subchs. VI and VII for specific requirements.

(5) CONFLICTING RULES. Where different sections of this chapter specify different requirements, the most restrictive requirement shall govern.

(6) RETROACTIVITY. The provisions of this chapter are not retroactively applied to existing facilities unless specifically stated in the administrative rule.

\* \* \* \* \*

#### SPECIAL NOTE #1

In addition to the requirements of this chapter, all frequenters and employers in public buildings and places of employment and employes in public sector places of employment are protected by the provisions of chapter Ind 1000-2000 - Safety and Health Code. Employes in private sector places of employment are protected by the regulations of 29 CFR 1910, OSHA 2206, Revised March 11, 1983, of the U.S. Department of Labor, Occupational Safety and Health Administration (OSHA).

#### SPECIAL NOTE #2

The Wisconsin Department of Natural Resources and the U.S. Environmental Protection Agency administer statutes and administrative rules and regulations which also pertain to flammable and combustible liquids. The regulated areas include discharges of hazardous substances and wastes, air emissions, discharges to ground and surface waters, and disposal of solid and hazardous wastes. Chapters 144, 147 and 160, Stats., should be consulted in addition to rules adopted by the Department of Natural Resources. The federal Resource Conservation and Recovery Act, Clean Air Act, Clean Water Act and Code of Federal Regulations should also be consulted. This rule is intended to satisfy the requirements of 40 CFR Parts 280 and 281 for Underground Storage Tanks: Technical Requirements and State Program Approval.

#### SPECIAL NOTE #3

Flammable and combustible liquid facilities and structures may be subject to compliance with additional requirements in applicable building codes, local zoning and similar ordinances.

\* \* \* \* \*

SUBCHAPTER II - DEFINITIONS

ILHR 10.01 DEFINITIONS. In this chapter, the following definitions shall apply:

(1)\* "Above ground release" means any release to the surface of the land or to surface water. This includes, but is not limited to, releases from the above ground portion of an underground storage tank system and above ground releases associated with overfills and transfer operations as the regulated substance moves to and from an underground storage tank system.

(2)\* "Ancillary equipment" means any device including, but not limited to, such devices as piping, fittings, flanges, valves, and pumps used to distribute, meter, or control the flow of regulated substances to and from an underground storage tank.

(3) "Approved" means acceptable to the department.

Note: The department will ordinarily accept items approved by a nationally recognized testing laboratory.

(4) "Authority having jurisdiction" means the department or its authorized deputies responsible for approving equipment, installations or procedures.

(5) "Authorized deputy" means a person as defined in s. 101.01 (1) (d) or 101.14 (2) (b), Stats., or any other person authorized by the department to perform duties within the scope of this code.

(6)\* "Below ground release" means any release to the subsurface of the land or to groundwater. This includes, but is not limited to, releases from the below ground portions of an underground storage tank system and below ground releases associated with overfills and transfer operations as the regulated substance moves to and from an underground storage tank.

(7)\* "Beneath the surface of the ground" means beneath the ground surface or otherwise covered with earthen materials.

(8) "Bulk plant" means that portion of a property where liquids are received by tank vessel, pipelines, tank car, or tank vehicle, and are stored or blended in bulk for the purpose of distributing such liquids by tank vessel, pipeline, tank car, tank vehicle, portable tank, or container.

(9) "Business day" means any day Monday to Friday, excluding legal holidays.

(10)\* "Cathodic protection" means a technique to prevent corrosion of a metal surface by making that surface the cathode of an electrochemical cell. A tank system may be cathodically protected through the application of either galvanic anodes or impressed current.

\* Definitions included in federal regulations.

(11)\* "Cathodic protection tester" means a person who can demonstrate an understanding of the principles and measurements of all common types of cathodic protection systems as applied buried or submerged metal piping and tank systems. At a minimum, such persons shall have education and experience in soil resistivity, stray current, structure-to-soil potential, and component electrical isolation measurements of buried metal piping and tank systems.

(12) "Centralized oil distribution system" means a system of piping through which oil is supplied from a separate central supply tank or tanks.

(13)\* "CERCLA" means the Comprehensive Environmental Response, Compensation, and Liability Act of 1980, as amended.

(14) "Certified cleaner" means a person certified by the department to remove accumulated sludges and remaining product from tanks which are to be closed, undergo a change in service, or otherwise completely emptied and inerted.

(15) "Certified inspector" means a person certified by the department to inspect storage tank systems.

(16) "Certified installer" means a person who is certified by the department to install and repair storage tank systems.

(17) "Certified liner" means a person certified by the department to install an interior lining to a storage tank.

(18) "Certified remover" means a person who is certified by the department to remove storage tank systems.

(19) "Certified site assessor" means a person certified by the department to conduct a site assessment and collect samples necessary for that site assessment.

(20) "Certified tightness tester" means a person who is certified by the department to perform tightness testing to determine the presence of leaks in storage tank systems.

(21) "Change-in-service" means continued use of a storage tank system which previously stored a regulated substance to store a nonregulated substance.

(22) "Combustible liquid" means a liquid having a flash point at or above 100°F. Combustible liquids are subdivided as follows:

(a) "Class II liquids" mean those having flash points at or above 100°F and below 140°F.

(b) "Class IIIA liquids" mean those having flash points at or above 140°F and below 200°F.

(c) "Class IIIB liquids" mean those having flash points at or above 200°F. This chapter does not cover Class IIIB liquids.

\* Definitions included in federal regulations.

Note #1: Where the terms "Combustible Liquids" or "Class III Liquids" are used in this chapter they mean Class IIIA liquids only.

Note #2: The upper limit of 200°F is given because the application of this chapter does not extend to liquids having flash points above 200°F and, therefore, this limitation should not be construed as indicating that liquids with higher flash points are noncombustible.

(23)\* "Compatible" means the ability of two or more substances to maintain their respective physical and chemical properties upon contact with one another for the design life of the tank system under conditions likely to be encountered in the underground storage tank system.

(24)\* "Connected piping" means all underground piping including valves, elbows, joints, flanges, and flexible connectors attached to a tank system through which regulated substances flow.

Note: For the purpose of determining how much piping is connected to any individual underground storage tank system, the piping that joins two underground storage tank systems should be allocated equally between them.

(25)\* "Consumptive use," with respect to heating oil, means consumed on the premises where the UST system is located.

(26) "Control, primary safety" means a safety control responsive directly to flame properties, sensing the presence or absence of flame and, in the event of ignition failure or unintentional flame extinguishment, causing safety shutdown.

(27) "Control, safety" means automatic controls, including relays, switches and other auxiliary equipment used to form a safety-control system, that are intended to prevent unsafe operation of the controlled equipment.

(28) "Contractor or farm fuel tanks" means tanks having a total aggregate capacity not greater than 200 gallons mounted on a pick-up truck or similar vehicle.

(29)\* "Corrosion expert" means a person who, by reason of thorough knowledge of the physical sciences and the principles of engineering and mathematics acquired by a professional education and related practical experience, is qualified to engage in the practice of corrosion control on buried or submerged metal piping systems and metal tanks. The person shall be accredited or certified as being qualified by the National Association of Corrosion Engineers or be a registered professional engineer who has education and experience in corrosion control of buried or submerged metal piping systems and metal tanks.

(30) "Department" means the department of industry, labor and human relations.

\* Definitions included in federal regulations.

(31)\* "Dielectric material" means a material that does not conduct direct electrical current. Dielectric coatings are used to electrically isolate underground storage tank systems from the surrounding soils. Dielectric bushings are used to electrically isolate portions of the underground storage tank system, such as the tank from piping.

(32)\* "Electrical equipment" means underground equipment that contains dielectric fluid that is necessary for the operation of equipment such as transformers and buried electrical cable.

(33)\* "Excavation zone" means the volume containing the tank system and backfill material bounded by the ground surface, walls, and floor of the pit and trenches into which the underground storage tank system is placed at the time of installation.

(34)\* "Existing" means installed or in place on or prior to the effective date of this chapter.

Note: The effective date of this chapter is . . .(Revisor to insert date)

(35)\* "Existing tank system" means a tank system used to contain an accumulation of regulated substances or for which installation has commenced on or prior to the effective date of this chapter or other specified date. Installation is considered to have commenced if the owner or operator has obtained all federal, state, and local approvals or permits necessary to begin physical construction of the tank system site or installation of the tank system and a continuous on-site physical construction or installation program has begun.

(36)\* "Farm tank" means a tank located on a tract of land devoted to the production of crops or raising animals, including fish, and associated residences and improvements. A farm tank shall be located on the farm property. "Farm" includes fish hatcheries, rangeland and nurseries with growing operations.

Note: See also Section 102.04 (3), Stats., for the definition of a farm operation.

(37) "Flammable liquid" means a liquid having a flash point below 100°F and having a vapor pressure not exceeding 40 pounds per square inch (absolute) at 100°F. These materials are also known as Class I liquids. Class I liquids are subdivided as follows:

(a) "Class IA" means those liquids having flash points below 73°F and having a boiling point below 100°F.

(b) "Class IB" means those liquids having flash points below 73°F and having a boiling point at or above 100°F.

(c) "Class IC" means those liquids having flash points at or above 73°F and below 100°F.

\* Definitions included in federal regulations.

(38) "Flash point" means the minimum temperature at which a flammable or combustible liquid will give off sufficient flammable vapors to form an ignitable mixture with air near the surface of the liquid or within the vessel as determined by the following test methods:

(a) ASTM D56 - Standard Test Method for Flash Point by Tag Closed Tester for liquids having a viscosity less than 45 SUS at 100°F and a flash point below 200°F;

(b) ASTM D93 - Standard Test Methods for Flash Point by Pensky-Martens Closed Tester for liquids having a viscosity of 45 SUS or more at 100°F or a flash point of 200°F or higher;

(c) As an alternate, ASTM D3278 - Standard Test Methods for Flash Point of Liquids by Setaflash Closed Tester, may be used for paints, enamels, lacquers, varnishes and related products and their components having flash points between 32°F and 230°F, and having a viscosity lower than 150 stokes at 77°F; and

(d) As an alternate, ASTM D3828 - Standard Test Methods for Flash Point by Setaflash Closed Tester, may be used for testing aviation turbine fuels.

(39)\* "Flow-through process tank" is a tank that forms an integral part of a production process through which there is a steady, variable, recurring or intermittent flow of materials during the operation of the process. Flow-through process tanks do not include tanks used for the storage of materials prior to their introduction into the production process or for the storage of finished products or by-products from the production process.

(40)\* "Free product" means a regulated substance that is present as a nonaqueous phase liquid, such as a liquid not dissolved in water.

(41)\* "Gathering lines" means any pipeline, equipment, facility or building used in the transportation of oil or gas during oil or gas production or gathering operations.

(42)\* "Hazardous substance underground storage tank system" means an underground storage tank system that contains a hazardous substance defined in section 101 (14) of CERCLA, but not including any substance regulated as a hazardous waste under Subtitle C, or any mixture of such substances and petroleum, and which is not a petroleum underground storage tank system.

(43)\* "Heating oil" means petroleum that is No. 1, No. 2, No. 4--light, No. 4--heavy, No. 5--light, No. 5--heavy, and No. 6 technical grades of fuel oil; other residual fuel oils, including Navy Special Fuel Oil and Bunker C; and other fuels when used as substitutes for one of these fuel oils. Heating oil is typically used in the operation of heating equipment, boilers, or furnaces.

(44)\* "Hydraulic lift tank" means a tank holding hydraulic fluid for a closed-loop mechanical system that uses compressed air or hydraulic fluid to operate lifts, elevators, and other similar devices.

\* Definitions included in federal regulations.



(45) "Important building" means a building occupied by one or more persons for other than incidental use or a building that has a high hazard use or a building that is sited with respect to a UST system so that it will have a detrimental effect on release response or fire control activities.

(46) "Incompetence" means: conduct which evidences a lack of ability to perform the functions or tasks required to protect the health, safety and welfare of the public; lack of knowledge of the fundamental principals of UST system installation, testing, removal, cleaning, relining, inspection or site assessment; or lack of knowledge of this chapter or an inability to apply those principles; or failure to maintain competency in the current practices and methods applicable to this chapter.

(47) "Interstitial monitoring" means a leak detection method which entails the surveillance of the space between an UST system's walls and the secondary containment system for a change in steady state conditions. In a double-walled tank, this change may be indicated by a loss of vacuum, a drop in pressure, a drop in the fluid level in a visible reservoir, or the detection of the regulated substance or water in the interstitial space or both. In a secondary containment system consisting of a natural or synthetic liner or a vault, the surveillance consists of frequent or continuous sampling from a monitoring well or interstitial monitor between the UST and the liner to detect the presence of regulated substance or water.

(48) "Inventory controls" means techniques used to identify a loss of product that are based on volumetric measurements in the tank and reconciliation of those measurements with product delivery and withdrawal records.

(49) "Liquid" means a substance which is neither solid nor gas at standard conditions of temperature, 60 degrees Fahrenheit, and pressure, 14.7 pounds per square inch absolute.

(50)\* "Liquid trap" means sumps, well cellars, and other traps used in association with oil and gas production, gathering, and extraction operations including gas production plants, for the purpose of collecting oil, water, and other liquids. The liquid traps may temporarily collect liquids for subsequent disposition or reinjection into a production or pipeline stream, or may collect and separate liquids from a gas stream.

(51) "Listed" means equipment or materials to which has been attached a label, symbol or other identifying mark of an organization acceptable to the department and concerned with product evaluation, that maintains periodic inspections of production of labeled equipment or materials and by whose labeling the manufacturer indicates compliance with appropriate standards or performance in a specified manner.

Note: The department accepts the following listing organizations:  
Underwriters Laboratories (UL).

(52) "Maintenance" means the normal operational upkeep to prevent an underground storage tank system from releasing product.

\* Definitions included in federal regulations.

(53) "Misconduct" means an act performed in UST system installation, testing, removal, cleaning, relining, inspection or site assessment functions or tasks which jeopardizes the interests of the public, including violation of federal or state laws, local ordinances or administrative rules relating to UST systems, preparation of deficient or falsified reports, failure to submit information or reports required by law or contract when requested by the municipality or the department, conduct which evidences a lack of trustworthiness, or misrepresentation of qualifications such as education, experience or certification.

(54)\* "Motor fuel" means petroleum or a petroleum-based substance that is motor gasoline, aviation gasoline, No. 1 or No. 2 diesel fuel, or any grade of gasohol, and is typically used in the operation of a motor engine.

(55) "Motor Vehicle" means a self-propelled motor-driven vehicle which is used for moving people or products on land, water or air.

(56) "Negligence" means failure by omission or commission to discharge the duty required to protect the health, safety and welfare of the public.

(57)\* "New tank system" means a tank system that will be used to contain an accumulation of regulated substances and for which installation has commenced after the effective date of this chapter or other specified date.

Note: See also "Existing tank system."

(58)\* "Noncommercial purposes" with respect to motor fuel means not for resale.

(59) "Oil Burner" means a device for burning oil, including, but not limited to, boilers, furnaces, water heaters, or ranges. A burner of this type may be furnished with or without a primary safety control; and it may be a pressure atomizing gun type, a horizontal or vertical rotary type, or a mechanical or natural draft vaporizing type.

(60) "Oil Burning Equipment" means an oil burner of any type together with its tank, piping, wiring, controls and related devices and including all oil burners, oil-fired units and heating and cooking appliances.

(61)\* "On the premises where stored" with respect to heating oil means storage tank systems located on the same property, or contiguous property of the same owner, where the stored heating oil is used.

(62)\* "Operational life" means the period beginning when installation of the tank system has commenced until the time the tank system is properly closed.

(63)\* "Operator" means any person in control of, or having responsibility for, the daily operation of the underground storage tank system.

(64)\* "Overfill release" means a release that occurs when a tank is filled beyond its capacity, resulting in a discharge of the regulated substance to the environment.

\* Definitions included in federal regulations.

(65) "Owner" means:

(a) In the case of an underground storage tank system in use on November 8, 1984, or brought into use after that date, any person who owns all or a portion of an underground storage tank system used for storage, use, or dispensing of regulated substances or the person owning the property on which the underground storage tank system is located; and

(b) In the case of any underground storage tank system not in use, any person who owned all or a portion of the underground storage tank system immediately prior to the discontinuation of its use, or the person owning the property on which the underground storage tank system is located.

(66)\* "Person" means an individual, trust, firm, joint stock company, federal agency, corporation, state, municipality, commission, political subdivision of a state, or any interstate body. "Person" also includes a consortium, a joint venture, a commercial entity, and the United States Government.

(67) "Petroleum" means crude oil, crude oil fractions, and refined petroleum fractions, including gasoline, kerosene, heating oils, and diesel fuels.

(68)\* "Petroleum underground storage tank system" means an underground storage tank system that contains petroleum or a mixture of petroleum with insignificant quantities of other regulated substances. Such systems include those containing motor fuels, jet fuels, distillate fuel oils, residual fuel oils, lubricants, petroleum solvents, and used oils.

(69)\* "Pipe" or "Piping" means a hollow cylinder or tubular conduit that is constructed of nonearthen materials.

(70)\* "Pipeline facilities", including gathering lines, means new and existing pipe rights-of-way and any equipment, facilities, or buildings.

(71) "Place of employment" means any location within the jurisdiction of the department pursuant to s. 101.02, Stats., at which flammable and combustible liquid tanks, their products and attached pumping systems are considered to be integral and indispensable parts of the place of employment or public building.

(72) "Positive sampling, test, or monitoring results" means the results of sampling testing, or monitoring using a method described in Part 4 of Subch. VI that indicate a release from an underground storage tank system has occurred.

(73) "Product" means a substance stored in an underground or aboveground storage tank.

\* Definitions included in federal regulations.

(74) "Public building" means any structure, including exterior parts of the building, such as a porch, exterior platform or steps providing means of ingress or egress, used in whole or in part as a place of resort, assemblage, lodging, trade, traffic, occupancy, or use by the public or by 3 or more tenants.

Note: This definition is taken from s. 101.01 (2) (g), Stats.

(75) "Pump, automatic oil" means a pump which is not an integral part of an oil burner that automatically pumps oil from the supply tank and delivers the oil by gravity under a constant head to an oil burning appliance. The pump is designed to stop pumping automatically in case of total breakage of the oil supply line between the pump and the appliance.

(76) "Pump, oil transfer" means an oil pump, automatically or manually operated, that transfers oil through continuous piping from a supply tank to an oil-burning appliance or to an auxiliary tank and is not designed to stop pumping automatically in case of total breakage of the oil supply line between the pipe and the appliance.

(77) "Readily accessible" means capable of being reached easily and quickly for operation, maintenance and inspection.

(78) "Regulated substance" means any flammable or combustible liquid.

Note: Any substance defined in section 101 (14) of CERCLA, excluding any substance regulated as a hazardous waste under subtitle C, that is a flammable or combustible liquid is a regulated substance.

(79) "Release" means any discharge, including, but limited to, spilling, leaking, pumping, pouring, emitting, emptying, leaching, dumping or disposal of a flammable or combustible liquid into groundwater, surface water or subsurface soils.

(80)\* "Release detection" means determining whether a release of regulated substance has occurred from the underground storage tank system into the environment or into the interstitial space between the underground storage tank system and its secondary barrier or secondary containment around it.

(81) "Remodeling or alteration" means a change or modification.

(82) "Repair" means to restore a tank or storage tank system component that has caused a release or may cause a release of product from the underground storage tank system.

(83) "Residential marine service station" means that portion of a one- or 2-family residential property where liquid fuels are stored in or dispensed for nonretail purposes from fixed equipment on land into the fuel tanks of self-propelled marine craft, including all facilities used for the storage, dispensing, and handling of flammable and combustible liquids.

\* Definitions included in federal regulations.

(84)\* "Residential tank" means a tank located on the same property as a one- or 2-family dwelling or on the same property as a residential building that falls under the scope of ch. ILHR 57 and used only by the residents of the property or for the maintenance of the property.

Note: Section ILHR 57.001 specifies that ch. 57 applies to all places of abode, including but not limited to: apartment buildings; garden apartments; rowhouses; townhouses; condominiums; hotels; motels; rooming houses; dormitories; convents; monasteries; homes for the aged; sheltered facilities for battered women as defined in s. 46.95, Stats., and community based residential facilities.

(85)\* "SARA" means the Superfund Amendments and Reauthorization Act of 1986.

(86) "Secondary containment" means a system installed around an UST that is designed to prevent a release from migrating beyond the secondary containment system outer wall in the case of a double-walled tank system or excavation area in the case of a liner or vault system before the release can be detected. Such a system may include, but is not limited to, impervious natural and synthetic liners, double-walls or vaults.

(87)\* "Septic tank" means a watertight covered receptacle designed to receive or process, through liquid separation or biological digestion, the sewage discharged from a building sewer. The effluent from such receptacle is distributed for disposal through the soil. Settled solids and scum from the tank are pumped out periodically and hauled to a treatment facility.

(88)\* "Stormwater or wastewater collection system" means piping, pumps, conduits, and any other equipment necessary to collect and transport the flow of surface water run-off resulting from precipitation, or domestic, commercial, or industrial wastewater to and from retention areas or any areas where treatment is designated to occur. The collection of stormwater and wastewater does not include treatment except where incidental to conveyance.

(89)\* "Surface impoundment" means a natural topographic depression, diked area, or man-made excavation other than an injection well formed primarily of earthen materials, although it may be lined with man-made materials.

(90)\* "Tank" means a stationary device designed to contain an accumulation of regulated substances and constructed of nonearthen materials, such as concrete, steel or plastic, that provide structural support.

(91) "Tank, auxiliary" for an oil-burning appliance, means a tank having a capacity of 60 gallons or less listed for installation in the supply piping between a burner and its main fuel supply tank. It may be included as an integral part of an automatic pump or a transfer pump, or may be a separate tank.

(92) "Tank, gravity" means a supply tank from which the product is delivered directly by gravity.

\* Definitions included in federal regulations.

(93) "Tank, storage" means a separate tank that is not connected to an appliance for consumption.

(94) "Tank, supply" means a separate tank connected directly or by pump to an appliance for consumption.

(95) "Tightness testing" means a procedure for testing the ability of a tank system to prevent an inadvertent release of any stored substance into the environment or, in the case of an UST system, intrusion of groundwater into a tank system.

(96)\* "Underground area" means an underground room, such as a basement, cellar, shaft or vault, providing enough space for physical inspection of the exterior of the tank situated on or above the surface of the floor.

(97)\* "Underground release" means any below ground release.

(98) "Underground storage tank" or "UST" means any one or combination of tanks, including connected pipes, that is used to contain an accumulation of regulated substances, and the volume of which, including the volume of connected underground pipes, is 10 percent or more beneath the surface of the ground. The term does not include any of the following or pipes connected to any of the following:

- (a) Septic tank;
- (b) Pipeline facility, including gathering lines, regulated under:
  1. The Natural Gas Pipeline Safety Act of 1968 (49 U.S.C. App. 1671, et seq.), or
  2. The Hazardous Liquid Pipeline Safety Act of 1979 (49 U.S.C. App. 2001, et seq.), or
  3. Which is an intrastate pipeline facility regulated under state laws comparable to the provisions of the law referred to in subd. 1. or 2;
- (c) Surface impoundment, pit, pond, or lagoon;
- (d) Storm water or waste water collection system;
- (e) Flow-through process tank;
- (f) Liquid trap or associated gathering lines directly related to oil or gas production and gathering operations; or
- (g) Storage tank situated in an underground area, such as but not limited to a basement, cellar, mine working, drift, shaft, or tunnel, if the storage tank is situated upon or above the surface of the floor.

\* Definitions included in federal regulations.

(99) "Underground storage tank system" or "UST system" means an underground storage tank, connected piping, underground ancillary equipment, and containment system, if any.

(100) "Unsaturated zone" means the subsurface zone containing water under pressure less than that of the atmosphere, including water held by capillary forces within the soil and containing air or gases generally under atmospheric pressure. This zone is limited above by the ground surface and below by the upper surface of the zone of saturation or the water table.

(101) "Upgrade" means the addition or retrofit of some systems such as cathodic protection of tanks or piping, lining, or spill and overfill controls to improve the ability of an underground storage tank system to prevent the release of product.

(102) "Valve, manual oil shutoff" means a manually operated valve in an oil line for the purpose of turning on or shutting off the oil supply to a burner.

(103)\* "Wastewater treatment tank" means a tank that is designed to receive and treat an influent wastewater through physical, chemical, or biological methods.

Note: Also see definition of terms as listed in the standards adopted by reference as part of this chapter in Subch. IV.

### SUBCHAPTER III - ADMINISTRATION AND ENFORCEMENT

#### ILHR 10.10 APPROVAL OF PROPOSED CONSTRUCTION, INSTALLATION OR OPERATION.

(1) GENERAL. (a) Plan review and written approval from the department or its authorized deputy shall be obtained before: commencing any construction of new or additional aboveground or underground tank installation or piping installation; change in operation of an installation from storage of a nonregulated substance to a regulated substance; upgrading to bring into compliance an existing piping or tank installation for the storage, handling or use of flammable or combustible liquids; addition of vapor or groundwater monitoring wells; addition of leak detection; addition of spill or overfill protection; tank lining; conversion of general service stations to self-service stations; or conversion to the use of key, card or code operated dispensing devices.

(b) Approval need not be obtained for the following:

1. Oil burning installations for one- and 2-family dwellings located aboveground or in basements; and

2. Fuel supply tanks of a motor vehicle, aircraft, watercraft, mobile power plants or mobile heating plants.

\* Definitions included in federal regulations.

(2) LOCAL APPROVAL. (a) Plan review and approval. Plans for installations in which all tanks for the storage handling, or use of flammable or combustible liquids have an individual capacity of less than 5000 gallons shall be submitted for review and approved in writing by the chief of the local fire department or other authorized agent. Review of plans for compliance with the groundwater protection provisions of this chapter shall be performed by a certified inspector.

(b) Exercise of jurisdiction for groundwater protection. 1.a. With the approval of the chief elected official of the municipality, the municipality shall determine if the fire department or other authorized agent will exercise jurisdiction over the groundwater protection-related provisions of this chapter. The municipality shall designate, in writing, to the department that the fire department or authorized agent will exercise jurisdiction over the groundwater protection provisions of this chapter for the entire upcoming 3-year period. The written designation shall be received by the department at least 3 months prior to the beginning of the 3-year period, and shall include the name of the certified inspector.

b. If the fire chief or other authorized agent elects to discontinue exercising jurisdiction as specified in subpar. a., the fire chief shall notify the department in writing and the discontinuance shall not begin until January 1 of the following year.

2. If the municipality elects not to exercise jurisdiction as specified in subd. 1, written notice to the department shall be provided. The department shall exercise jurisdiction over the groundwater protection-related provisions of this chapter in that municipality for that upcoming year or secure another authorized agent.

3. The department shall forward payment to a fire department or other authorized agent which exercises jurisdiction for the enforcement of the groundwater related provisions of this code. The amount of the payment shall be determined by the department and based on the number of underground storage tank use permits issued for tanks within the area of jurisdiction.

(3) DEPARTMENTAL APPROVAL. (a) Departmental approval shall be obtained as follows:

1. Installations of tank and piping systems, as specified in sub. (2), but located in areas where the authority to approve has not been granted to the fire chief or authorized agent shall be approved in writing by the department.

2. Installations in which one or more tanks for storage, handling or use of flammable or combustible liquid will have individual capacity of 5,000 gallons or larger.

(b) The department shall review and make a determination on an application for installation approval and for plan review within 15 business days of receiving the required information and fees.

(4) PLANS, SPECIFICATION AND INFORMATION. (a) Plans, specifications and information submitted to the department or fire chief or other authorized agent for review and approval shall contain the following:



1. At least 4 sets of plans, which are clear, legible and permanent copies, and one copy of specifications, fees and a completed application.

2. The name of the owner; the name of the person, firm or corporation proposing the construction or installation, if other than the owner; the address of the facility including the names of adjacent streets and highways;

3. A plot plan, drawn to a minimum scale of 1 inch equals 20 feet, indicating the location of the installation with respect to property lines, lot lines, adjoining streets or alleys, fences including those installed over or through any part of the system, and other buildings on the same lot or property. The plot plan shall indicate the location of buildings, other tanks, loading and unloading docks, underground utilities, sanitary sewers, storm sewers, water mains, private water mains, water service piping, water wells, water reservoirs and any stream or body of water which is within 200 feet of the tank. The class of construction of each building shall also be indicated;

Note: See ss. ILHR 10.342 for additional rules and information regarding separation from water wells and reservoirs.

4. The location, size and capacity of each tank and the class of liquid to be stored, the location of all piping runs and spacing between all tanks and piping;

5. The type of tank supports, clearances including clearances between tanks, type of venting and pressure relief used and combined capacity of all venting and relief valves on each tank for aboveground storage;

6. The location of fill, gauge and vent pipes and other openings for underground storage tanks;

7. Additional data and information regarding storage, handling or use of flammable or combustible liquids within buildings or enclosure to demonstrate compliance with the requirements of this chapter;

8. Location of burners, tanks, pumps, piping and control valves and the elevations of buildings and the lowest floor or pit in relation to the installation for oil burning equipment;

9. The distances to dispensers, sizes of islands and traffic flow patterns or vehicle routes around or through the facility;

10. Information and specifications describing the design and placement of leak detection systems including the results of any site assessments conducted in accordance with s. ILHR 10.61 (6)(f) or 10.61 (5)(f) for groundwater monitoring or vapor monitoring, if used;

11. Information regarding the type and operation of corrosion protection system for tanks and piping, if used;

12. Information regarding the type of secondary containment system, if used;

13. Specifications describing the spill and overfill protection devices;

14. Information regarding the compatibility of the tank and piping system with flammable and combustible liquids;

15. A copy of an easement that reflects any property not owned by the system operator on which any portion of the system is located or any vehicle is parked while fueling;

16. Information and specifications on materials, equipment and devices to be used in the project that do not have material approval numbers;

17. Any material approval numbers issued in accordance with s. ILHR 10.125 for materials to be used in the project; and

18. Any other information requested on the installation application form (SBD-9).

(b) In addition to the provisions specified in par. (a), plans for service stations involving the use of automatic dispensing units shall indicate the location of emergency controls and shall include the following, if applicable:

1. The location and details of the key, card, coin, code or remote operated dispensing devices;

2. A copy of the agreement between the key, card, coin, or code-holder and the station owner; and

3. A copy of the description of the program used to train those persons who will operate the key, card, coin, code or remote dispensing devices.

Note: See Appendix A for a sample format dispensing equipment dispensing agreement form/training program.

(5) LOCAL REGULATIONS. This chapter may not limit the power of cities, villages and towns to make, or enforce, additional or more stringent regulations, provided the regulations do not conflict with this chapter, or with any other rule of the department, or law.

(6) APPLICATION FOR APPROVAL. (a) A Flammable and Combustible Liquid Tanks Installation and Plan Review Application form shall be included with each application for approval.

Note: See Appendix A for an example of the Flammable and Combustible Liquid Tanks Installation and Plan Review Application form (SBD-9). Form SBD-9 is available from the Department of Industry, Labor and Human Relations, Division of Safety and Buildings, P.O. Box 7969, Madison, Wisconsin 53707, or from the local fire department or authorized agent.

(b) If, upon examination, the department or an authorized deputy determines that the plans and the application for approval substantially conform to the provisions of this chapter, a conditional approval, in writing, will be granted. All noncomplying code conditions stated in the conditional approval shall be corrected before or during construction or installation. A conditional approval issued by the department or authorized deputy shall not be construed as an assumption of any responsibility for the design or construction of a flammable and combustible liquid facility. The fire chief or authorized agent shall be notified at least 5 days prior to commencement of installation.

(c) A letter shall be sent to the designer and the owner of record with a statement relating to the examination of the plans and citing the conditions of approval or denial. The plans shall be dated and stamped "Conditionally Approved" or "Not Approved" whichever applies. The department shall retain one copy of the plans for all projects. The department shall forward one copy of the plans and approval letter and Form SBD-9 to the fire department or authorized deputy having jurisdiction. The remaining 2 sets of plans shall be returned to the person designated on the plans approval application. The owner shall be responsible for maintaining one set of plans on site during all phases of installation.

(d) If the department or authorized deputy having jurisdiction determines that the plans or application do not substantially conform to the provisions of this chapter, the application for conditional approval will be denied, in writing.

(e) In the event of a dispute as to whether the information submitted to a local official having jurisdiction shows compliance with the provisions of this chapter, the application shall be submitted to the department for review and the decision of the department shall govern.

ILHR 10.105 PLAN REVISION. Any change in the initial installation which deviates from original approved or conditionally approved plans shall be submitted for review as a revision. Changes to facilities which shall be submitted for review as a revision include changes in tank placement, size of tank, length of piping run, and changes in monitoring equipment. Additions or modifications to systems after the closing of the excavation and commencement of system operation shall be submitted for review as a new installation.

ILHR 10.11 REVOCATION OF APPROVAL. The department or authorized deputy may revoke any approval issued under the provisions of this chapter for any false statements or misrepresentation of facts upon which the approval was based.

ILHR 10.12 DEPARTMENT LIMITATION AND EXPIRATION OF PLAN APPROVAL. Plan approval by the department or its authorized agent shall expire 2 years after the date indicated on the approved plans, if construction or installation has not commenced within that 2 year period.

ILHR 10.125 SPECIFIC APPROVAL OF MATERIALS, EQUIPMENT AND DEVICES. (1) SPECIFIC APPROVAL REQUIRED. Specific approval shall be obtained in writing from the department for the following materials, equipment and devices:

(a) The following leak detection devices:

1. Volumetric tank tightness testing methods;
2. Nonvolumetric tank tightness testing methods;
3. Automatic tank gauging systems;
4. Liquid phase out-of-tank product detectors;
5. Statistical inventory reconciliation methods; and
6. Pipeline leak detection systems;

(b) Liners for dikes, except asphalt and concrete liners, as specified in s. ILHR 10.345 (e);

(c) Flex connectors; and

(d) Any material, equipment or device not submitted for review and approval for a specific installation via the plan approval process under s. ILHR 10.10.

(2) APPLICATION. (a) General. Application for approval shall include sufficient data, tests and other evidence from an independent third party to prove that the material equipment or device meets the standards required in this chapter. Upon receipt of a fee and a written application, the department may issue an approval number for the material equipment or device. The department shall review and make a determination on an application for approval within 30 business days of receipt of all forms, fees, information, and documents required to complete the review.

(b) Tank Leak detection devices and systems. The applications for approval of leak detection devices and systems specified in subs. (1)(a) 1. to 5. shall include certification from an independent third party that the leak detection device or system has been evaluated in accordance with the applicable Environmental Protection Agency (EPA) standard test procedures for evaluating leak detection methods and complies with the requirements of s. ILHR 10.61 or 10.615.

(c) Pipeline leak detection systems. The applications for approval of pipeline leak detection systems shall include the results of an evaluation conducted by an independent third party using a test procedure specified in this paragraph, or equivalent.

1. The test procedure shall consider temperature, bulk modulus and leak rate as influences on performance.

2. The testing shall be done at a variety of temperature differences between the product in the line and the soil ranging from negative 25°F to positive 25°F.

3. At least two different types of piping with two different bulk moduluses must be used in the testing.

4. Any of the following testing approaches will be acceptable:

a. Test at an instrumented test facility where actual piping runs installed specifically for testing and includes the instruments necessary to closely control and monitor test and piping conditions, such as temperature, over 1 month using two pipes, controlling temperature, and using 25 different leak rates. Conduct at least 75 tests;

b. Test at 5 or more retail gas stations over 6-12 months, using different areas and seasons. Lines must be known to be tight. At least 12 tests per site for a total of at least 60 tests;

c. Test at 10 or more retail gas stations over a 6-12 month period. Cover a wide range of climatic regions. Conduct at least 12 tests at each site for at least 120 tests; or

d. Develop physical models. Use field data for validation or conduct at least 5 tests at an instrumented facility. For volumetric piping release detection methods, use 25 randomly selected leak rates.

(d) Dike Liners. Applications for approval of synthetic and manufactured dike liners shall include information on product compatibility, construction methods, thickness, materials, field installation and seam testing procedures, and liner bedding and soil cover quality to demonstrate suitability for various types of installations.

Note: See Appendix A for an example of the Wisconsin Building Material Approval Application (SBD-8028). Form SBD-8028 is available from the Department of Industry, Labor and Human Relations, Division of Safety and Buildings, P.O. Box 7969, Madison, Wisconsin 53707.

ILHR 10.13 REGISTRATION - NEW AND REPLACEMENT ABOVEGROUND AND UNDERGROUND STORAGE TANKS. (1) GENERAL. (a) 1. All new and replacement underground storage tanks installed on or after the effective date of this subsection shall be registered with the department at installation.

2. Except for pipeline facilities, aboveground tanks of 110 gallons or less capacity, farm and residential aboveground tanks of 1,100 gallons or less capacity storing petroleum not for resale, aboveground tanks used for storing heating oil for consumptive use on the premises where stored and tanks owned by the state or federal government, all new and replacement aboveground petroleum storage tanks installed on or after the effective date of this subsection shall be registered with the department at installation.

(b) The owner of the storage tank shall be responsible for registering the storage tank upon installation.

(2) REGISTRATION PROCEDURE. An Underground Storage Tank Registration Form (SBD-7437) for each underground storage tank shall be completed and submitted to the department by the tank owner. A Flammable and Combustible Liquid Tanks Installation and Plan Review Application form (SBD-9), plot plan and other documentation for review and acceptance for each new or replacement underground storage tank shall be completed and submitted to the department by the tank owner.

Note #1: See Appendix A for examples of the Underground Storage Tank Registration Form (SBD-7437), the Aboveground Storage Tank Registration Form (SBD-8731), and Flammable and Combustible Liquid Tanks Installation and Plan Review Application Form (SBD-9). Forms (SBD-7437), (SBD-8731) and (SBD-9) are available from the Department of Industry, Labor and Human Relations, Division of Safety and Buildings, P.O. Box 7969, Madison, Wisconsin 53707, or from the local fire department or authorized agent.

Note #2: Eligibility for Petroleum Environmental Clean Up Fund Act (PECFA) funds requires prior tank registration.

ILHR 10.14 REGISTRATION - EXISTING ABOVEGROUND AND UNDERGROUND STORAGE TANKS. (1) GENERAL. (a) 1. All in-use or temporarily out-of-service underground storage tanks installed prior to the effective date of this subsection shall be registered with the department.

2. Except for pipeline facilities, aboveground tanks of 110 gallons or less capacity, farm and residential aboveground tanks of 1,100 gallons or less capacity storing petroleum not for resale, and aboveground tanks used for storing heating oil for consumptive use on the premises where stored and tanks owned by the state or federal government, all in-use or temporarily out-of-service aboveground petroleum storage tanks installed prior to the effective date of this subsection shall be registered by the department.

(b) 1. The owner of the storage tank shall be responsible for registering the tank.

2. The owner of an existing storage tank previously used to store a nonregulated substance undergoing a change to store a regulated substance shall be responsible for registering the change operation of the underground storage tank within 10 days of the change.

3. The new owner of an existing storage tank shall be responsible for registering the change of ownership within 10 days of the change.

4. The owner of an existing tank system which undergoes any of the following changes shall be responsible for registering the change within 10 days of the change.

- a. A change in service;
- b. Permanent or temporary closure;
- c. A change in service or permanent closure of a temporarily closed tank;
- d. The addition of release detection, spill or overfill control or corrosion protection of any part of the system; and
- e. Tank lining.

5. The owner of an existing tank at a facility which undergoes a name change or an owner who undergoes a change of mailing address shall be responsible for registering the name change or address change within 10 days of the change.

(2) REGISTRATION PROCEDURE. An Underground Storage Tank Registration Form (SBD-7437) for each underground storage tank shall be completed and submitted to the department by the tank owner. An Underground Storage Tank Use Permit Application (SBD-7658) shall be sent by the department to the underground storage tank owner in response to the registration within the timeframes specified in s. ILHR 10.17.

Note #1: See Appendix A for examples of the Underground Storage Tank Registration Form (SBD-7437), Aboveground Storage Tank Registration Form (SBD-8731), and the Underground Storage Tank Use Permit Application (SBD-7658). Forms SBD-7437, SBD-8731 and SBD-7658 are available from the Department of Industry, Labor and Human Relations, Division of Safety and Buildings, P.O. Box 7969, Madison, Wisconsin 53707, or from the local fire department or authorized agent.

Note #2: Eligibility for Petroleum Environmental Clean Up Fund Act (PECFA) funds requires prior tank registration.

ILHR 10.15 REGISTRATION - PERMANENTLY CLOSED OR REMOVED ABOVEGROUND AND UNDERGROUND STORAGE TANKS. (1) GENERAL. (a) 1. All permanently closed or removed underground storage tanks except farm and residential tanks of 1,100 gallons or less capacity used for storing motor fuel for noncommercial purposes and underground storage tanks used for storing heating oil for consumptive use on the premises where stored, shall have been registered with the department by the effective date of this chapter.

2. All permanently closed or removed underground storage tanks which are farm, residential, underground storage tanks of 1,100 gallons or less capacity used for storing motor fuel for noncommercial purposes and underground storage tanks for storing heating oil for consumptive purposes on the premises where stored shall have been registered by the effective date of this chapter.

3. Except for pipeline facilities, aboveground tanks of 110 gallons or less capacity, farm and residential aboveground tanks of 1,100 gallons or less capacity storing petroleum not for resale, aboveground tanks used for storing heating oil for consumptive use on the premises where stored and tanks owned by the state or federal government, all petroleum aboveground storage tanks permanently closed or removed shall be registered with the department.

4. Storage tanks which are permanently closed or removed after the effective date of this chapter or the discovery of which occurs after the effective date of this chapter shall be registered with the department within 15 business days of permanent closure or removal or within 15 business days of discovery.

(b) The owner of the permanently closed underground storage tank or the land from which the underground storage tank was removed shall be responsible for registering the tank as specified in par. (a).

Note: The effective date of this chapter is [Revisor insert date].

(2) REGISTRATION PROCEDURE. An Underground Storage Tank Registration Form SBD-7437 for each permanently closed or removed underground storage tank shall be completed and submitted to the department by the tank owner.

Note #1. See Appendix A for examples of the Underground Storage Tank Registration Form (SBD-7437) and the Aboveground Storage Tank Registration Form (SBD-8731). Forms SBD-7437 and SBD-8731 are available from the Department of Industry, Labor and Human Relations, Division of Safety and Buildings, P.O. Box 7969, Madison, Wisconsin 53707, or from the local fire department or authorized agent.

Note #2. Compliance with this section satisfies the mandates for abandoned tank registration specified in s. 101.142, Stats., and the federal Underground Storage Tank Program authorized under the Resource Conservation and Recovery Act (RCRA).

Note #3: Eligibility for Petroleum Environmental Clean-Up Fund Act (PECFA) funds requires prior tank registration.

ILHR 10.16 NEW AND REPLACEMENT UNDERGROUND STORAGE TANK USE PERMIT.

(1) APPLICATION. (a) The owner of any new or replacement underground storage tank, with the exception of farm or residential underground tanks of 1100 gallons or less used for storing motor fuel for noncommercial purposes and underground tanks storing heating oil for consumptive purposes on the premises where stored, shall obtain an underground storage tank use permit from the department for each underground storage tank as specified in this section.

(b) The Underground Storage Tank Use Permit Application shall be obtained after the underground storage tank is registered as specified in s. ILHR 10.13, and plan approval as specified in s. ILHR 10.10 is obtained and the underground storage tank is installed, but before the underground storage tank is placed in operation.

(2) PERMIT PROCEDURE. (a) An Underground Storage Tank Use Permit Application (SBD-7658) for each new or replacement underground storage tank shall be completed and submitted by the tank owner to the department for review and approval together with the following:

1. A completed, signed Underground Storage Tank Installation Inspection Checklist (SBD-6294);

2. The most recent test report for the cathodic protection system or impressed current system, if utilized;

3. Proof of financial responsibility as specified in Subch. VIII;

4. A tank locator diagram, map or plot plan drawn to scale specifying the exact individual tank location in relation to streets, buildings, and compass direction, unless previously submitted to the department as part of the plan review and approval process; and

5. Proof of compliance with leak detection requirements.

(b) Upon review and acceptance of the information specified in par. (a), the department shall issue an Underground Storage Tank Use Permit (SBD-7659) for each underground storage tank.



Note: See Appendix A for examples of the Underground Storage Tank Use Permit Application (SBD-7658) and the Underground Storage Tank Use Permit (SBD-7659). Form SBD-7658 is available from the Department of Industry, Labor and Human Relations, Division of Safety and Buildings, P.O. Box 7969, Madison, Wisconsin 53707, or from the local fire department or authorized agent.

(3) DEPARTMENT PERMIT PROCESSING TIMES. The department shall review and make a determination on the Underground Storage Tank Use Permit Application (SBD-7658) within 30 business days of receipt of the completed forms and required information.

(4) PERMIT EXPIRATION. (a) The underground storage tank use permit shall expire 3 years from the date of issuance.

(b) The owner of the underground tank shall be sent a renewal notice of the underground storage tank use permit for the underground storage tank by the department before the expiration of the current permit.

(5) REPERMIT PROCEDURE. (a) The owner shall submit the Underground Storage Tank Use Permit Application Form (SBD-7658), test reports, inspection report, and required information as specified in sub. (2) for the repermit procedure.

(b) The department shall process the repermit request as specified in sub. (2) (b) within the processing times as specified in sub. (3).

ILHR 10.17 EXISTING UNDERGROUND STORAGE TANK USE PERMIT PROCEDURE. (1) APPLICATION. (a) The owner of each existing in-use or temporarily out-of-service underground storage tank, with the exception of farm or residential underground storage tanks of 1,100 gallons or less used for storing motor fuel for noncommercial purposes and underground storage tanks storing heating oil for consumptive purposes on the premises where stored, shall be sent an Underground Storage Tank Use Permit Application by the department for each underground storage tank as specified in this section.

(b) The Underground Storage Tank Use Permit Application shall be obtained only after tank registration as specified in s. ILHR 10.14 and in accordance with the following:

| Year Underground Storage Tank was Installed | Use Permit Application No Later Than              |
|---|---|
| Before 1972 or Date Unknown                 | One Year After the Effective Date of the Rules    |
| 1973 - 1982                                 | Two Years After the Effective Date of the Rules   |
| 1983 - Effective Date of the Rules          | Three Years After the Effective Date of the Rules |

Note: The effective date of the rules is [Revisor insert date].

(2) PERMIT PROCEDURE. (a) An Underground Storage Tank Use Permit Application Form SBD-7658 for each existing in-use or temporarily out-of-service underground storage tank shall be completed and submitted by the tank owner to the department for review and approval together with the following:

1. The most recent test report for the cathodic protection system or impressed current system, if utilized;

2. Information regarding the method of leak detection used and proof of system code compliance;

3. A description of the spill and overfill protection devices, if any;

4. Documentation demonstrating the financial responsibility for the tank; and

5. A tank locator diagram, map or plot plan drawn to scale specifying the exact individual tank location in relation to streets, buildings, and compass direction, unless previously submitted to the department as part of the plan review and approval process.

(b) Upon review and acceptance of the information specified in par. (a), the department shall issue an Underground Storage Tank Use Permit (SBD-7659) for each underground storage tank.

Note: See Appendix A for examples of the Underground Storage Tank Use Permit Application (SBD-7658), the Underground Storage Tank Use Permit (SBD-7659) and the Underground Storage Tank Installation Inspection Checklist (SBD-6294). The forms are available from the Department of Industry, Labor and Human Relations, Division of Safety and Buildings, P.O. Box 7969, Madison, Wisconsin 53707, or from the local fire department or authorized agent.

(3) DEPARTMENT PERMIT PROCESSING TIMES. (a) Except as provided in par. (b), the department shall review and make a determination on the Underground Storage Tank Use Permit Application within 30 business days of receipt of the completed forms and required information.

(b) For those Underground Storage Tank Use Permit Applications submitted during the first 18 months after the effective date of this section, the department shall review and make a determination within 90 business days of receipt of the completed forms and required information.

(4) PERMIT EXPIRATION. (a) The underground storage tank use permit shall expire 3 years from the date of issuance.

(b) The owner of the underground storage tank shall obtain a renewal of the underground storage tank use permit for the underground storage tank before the expiration of the current use permit.

(5) REPERMIT PROCEDURE. (a) The owner shall submit the use permit application form, test reports and required information as specified in sub. (2) for the repermit procedure.

(b) The department shall process the repermit request as specified in sub. (2) (b) within the processing times as specified in sub. (3).

ILHR 10.18 ENFORCEMENT AND INSPECTIONS. (1) ENFORCEMENT. The rules in this chapter shall be enforced by the department or its deputies or authorized agents, and by all local officials or bodies having jurisdiction to approve plans or specifications or issue permits for construction, alterations or installations within the scope of this chapter or having authority to investigate and eliminate related fire hazards.

(2) INSPECTIONS. (a) New and replacement installations. 1. Inspections shall be conducted during the installation of new or replacement storage tanks or piping systems within the scope of subch. VI and aboveground tanks of capacity greater than 5000 gallons under the scope of subch. V and heating oil tanks of greater than 4000 gallon capacity under the scope of subch. VII. Inspections shall be conducted by an authorized deputy or agent of the department to ascertain whether or not the construction or installations conform to the conditionally approved plans, the conditional approval letter, and the provisions of this chapter.

2. a. After review and approval is granted, the installer shall notify the chief of the local fire department or authorized deputy or agent, in writing within 5 days, before starting an installation.

b. The chief of the fire department or authorized deputy or agent shall inspect the installation and give written notice of approval or disapproval to the owner on a completed, signed Underground Storage Tank Installation Inspection Checklist (Form SBD-6294).

Note: See Appendix A for example of Underground Storage Tank Installation Inspection Checklist (SBD-6294). The original copy is to be given to the owner and copies furnished to and retained by the department and the fire department or authorized agent as part of their permanent file.

c. The certified tank installer who installs a tank may complete the Underground Storage Tank Inspection Checklist (form SBD-6294) if the certified inspector is unable to do so.

(b) Existing installations. Inspections at existing installations shall be conducted periodically by an authorized deputy of the department to determine if the installation remains in conformance with the provisions of this chapter.

Note: Inspection staff from the Bureau of Petroleum Inspection and Fire Protection will conduct inspections as part of their petroleum product sampling inspections. Local certified inspectors will conduct inspections of tank facilities.

(c) Written notice. When the tank is inspected by a certified inspector, all violations of the rules shall be specifically listed including the allotted time to correct the violation.

(3) **SYSTEM SHUTDOWN.** Persons with enforcement authority under this chapter shall have the authority to shut down UST systems or components of UST systems via the issuance of orders and disabling of the system with locks under the following conditions:

(a) Immediate shutdown. Underground Storage Tank systems or their components which pose an immediate danger to life, safety or health shall be subject to immediate shutdown. Conditions which cause immediate danger to life, safety, or health include, but are not limited to: visual evidence of leakage of flammable or combustible liquid, immediate human exposure to flammable or combustible liquids, such as presence in drinking water or vapors in buildings; broken equipment resulting in uncontrolled release of flammable or combustible liquids; or free flammable or combustible liquid product going to surface water.

(b) Shutdown after investigation. Underground Storage Tank systems or their components for which there is clear and present evidence of a release to the environment shall be shutdown. Clear and present evidence of a release to the environment includes, but is not limited to: inventory records, precision tank integrity testing results, leak detection system results or other specific physical evidence associated with a particular tank or system.

(c) Shutdown after long term violation. Underground Storage Tank systems or components for which there is a continuing code violation under this chapter will be subject to shutdown if the following conditions are met:

1. An order is issued with a specific compliance date and a period for compliance;
2. The first reinspection made after the specified compliance date shows that compliance has not been achieved;
3. A second compliance date is set with a period for compliance;
4. Reinspection after the second compliance date shows that compliance is still not achieved; and
5. The owner has not filed a written appeal with the department within 15 days of receiving the order.

ILHR 10.19 GROUNDWATER PROTECTION INSPECTIONS. All inspections for enforcement of the groundwater protection provisions of this chapter shall be conducted by inspectors certified by the department.

ILHR 10.20 FEES. Fees shall be submitted to the department as specified in s. Ind 69.10. Fees shall be submitted at the time the application for approval is submitted. No plan examinations, approvals or inspections may be made until the fees are received.

Note: See s. Ind 69.10 for distribution of fees to authorized agents for providing inspection services. Distribution of fees to authorized agents will occur after the inspection is completed and a completed and signed form SBD-6294 is submitted to the department.

ILHR 10.21 APPEALS. As specified in s. 227.12, Stats., any municipality, corporation or any 5 or more persons having an interest in a rule may appeal to the department requesting the adoption, amendment or repeal of the rule.

ILHR 10.22 PETITION FOR VARIANCE. (1) PROCEDURE. The department shall consider and may grant a variance to an administrative rule upon receipt of a completed petition for variance form from the owner and a position statement from the fire department having responsibility, provided an equivalency is established in the petition for variance which meets the intent of the rule being petitioned. The department shall charge a fee for processing the petition for variance. The department may impose specific conditions in a petition for variance to promote the protection of the health, safety or welfare of the employes or the public. Violation of those conditions under which the petition is granted shall constitute a violation of this chapter.

(2) PETITION PROCESSING TIME. Except for priority petitions, the department shall review and make a determination on a petition for variance within 30 business days of receipt of all calculations, documents and fees required to complete the review. The department shall process priority petitions within 10 business days.

Note: Section 101.02 (6), Stats., and ch. ILHR 3 outline the procedure for submitting petitions to the department and the department's procedures for hearing petitions. See Appendix A for an example of the Petition for Variance Form (form SB-8) and the Fire Department Position Statement Form (form SB-8A).

ILHR 10.23 PENALTIES. Penalties for violations of the rules of this chapter shall be assessed in accordance with s. 101.09 (5), Stats., or 40 CFR s. 281.41 of US EPA regulations or both.

Note: Section 101.09 (5), Stats., states "(5) PENALTIES. Any person who violates this section or any rule or order adopted under this section shall forfeit not less than \$10 nor more than \$1,000 for each violation. Each violation of this section or any rule or order under this section constitutes a separate offense and each day of continued violation is a separate offense." Section 281.41 of 40 CFR, US EPA regulations requires the department to assess fines of up to \$5,000 or more for each tank for each day of violation.

#### SUBCHAPTER IV - STANDARDS

ILHR 10.25 ADOPTION OF STANDARDS BY REFERENCE. (1) CONSENT TO INCORPORATE. Pursuant to s. 227.21, Stats., the attorney general and the revisor of statutes have consented to the incorporation by reference of the following standards:

(a) American Petroleum Institute, 1220 L Street, Northwest, Washington, D.C. 20005.

1. Welded Steel Tanks For Oil Storage, API Standard No. 650, 8th Edition, 1988;

2. Recommended Practice for Abandonment or Removal of Used Underground Service Station Tanks, API Publication 1604, 2nd Edition, 1987;

3. Installation of Underground Petroleum Storage Systems, API Publication 1615, 4th Edition, 1987;

4. Recommended Practice for Bulk Liquid Stock Control at Retail Outlets, API Publication 1621, 4th Edition, 1987;

5. Recommended Practice for Interior Lining of Existing Steel Underground Storage Tanks, API Publication 1631, 2nd Edition, 1987;

6. Cathodic Protection of Underground Petroleum Storage Tanks and Piping Systems, API Publication 1632, 2nd Edition, 1987;

7. Cleaning Petroleum Storage Tanks, API Publication 2015, 3rd Edition, 1985; and

8. Repairing Crude Oil Liquified Petroleum Gas and Product Pipelines, API Publication 2200, 2nd Edition, 1983.

(b) American National Standards Institute, 1430 Broadway, New York, New York 10018.

1. Chemical Plant and Petroleum Refinery Piping, ANSI/ASME B31.3, 1990; and

2. Liquid Petroleum Transportation Piping Systems, ANSI/ASME B31.4, 1989; and

3. Standard on Welded and Seamless Wrought-Steel Pipe, ANSI B36.10M, 1985.

(c) American Society for Testing and Materials (ASTM), 1916 Race Street, Philadelphia, Pennsylvania 19103.

1. Standard Test Method for Penetration of Bituminous Materials, ASTM D5-86;

2. Standard Test Method for Flash Point by Tag Closed Tester, ASTM D56-87;

3. Standard Method for Distillation of Petroleum Products, ASTM D86-82;

4. Standard Test Methods for Flash Point by Pensky-Martens Closed Tester, ASTM D93-85;

5. Standard Test Method for Vapor Pressure of Petroleum Products (Reid Method), ASTM D323-82;

6. Standard Test Methods for Flash Point of Liquids by Setaflash Closed Tester, ASTM D3278-82;

7. Standard Test Methods for Flash Point by Setaflash Closed Tester, ASTM D3828-87; and

8. Specification for Glass-Fiber-Reinforced Polyester Underground Petroleum Storage Tanks, ASTM D4021-86.

(d) Association for Composite Tanks, 1900 Frankfurst Avenue, Baltimore, Maryland 21226; Specifications for Fabrication of FRP Clad/Composite Underground Storage Tanks, Standard ACT-100, 1989.

(e) Environmental Protection Agency, Office of Underground Storage Tanks, Washington, DC 20460.

1. Standard Test Procedures for Evaluating Leak Detection Methods: Volumetric Tank Tightness Test Methods, March 1990;

2. Standard Test Procedure for Evaluating Leak Detection Methods: Nonvolumetric Tank Tightness Test Methods, March 1990;

3. Standard Test Procedures for Evaluating Leak Detection Methods: Automatic Tank Gauging Systems, March 1990;

4. Standard Test Procedure for Evaluating Leak Detection Methods: Liquid-Phase Out-of-Tank Product Detectors, March 1990;

5. Standard Test Procedure for Evaluating Leak Detection Methods: Vapor-Phase Out-of-Tank Product Detectors, March 1990; and

6. Standard Test Procedures for Evaluating Leak Detection Methods: Statistical Inventory Reconciliation Methods, June 1990;

Note: Copies of EPA publications may also be obtained from EPA Regional Offices by calling the RCRA/Superfund Hotline at 1-800-424-9346.

(f) National Association of Corrosion Engineers, P.O. Box 218340, Houston, Texas 77218.

1. Recommended Practice, Control of External Corrosion on Underground or Submerged Metallic Piping Systems, NACE Standard RP-01-69, 1983 Revision; and

2. Recommended Practice, Control of External Corrosion of Metallic Buried, Partially Buried, or Submerged Liquid Storage Systems, NACE Standard RP-02-85, 1985 Edition.

(g) National Fire Protection Association (NFPA), Batterymarch Park, Quincy, Massachusetts 02269.

1. Standard for the Installation of Sprinkler Systems, NFPA No. 13-1989;

2. Standard for Dry Chemical Extinguishing Systems, NFPA No. 17-1990;

3. Flammable and Combustible Liquids Code, NFPA No. 30-1987;

4. Automotive and Marine Service Station Code, NFPA No. 30A-1987;

5. Standard for Spray Application Using Flammable and Combustible Materials, NFPA No. 33-1989;

6. Standard for Dipping and Coating Processes Using Flammable or Combustible Liquids, NFPA No. 34-1989;

7. Standard for the Manufacture of Organic Coatings, NFPA No. 35-1987;

8. Standard for the Installation and Use of Stationary Combustion Engines and Gas Turbines, NFPA No. 37-1990;

9. Standard on Fire Protection for Laboratories Using Chemicals, NFPA No. 45-1986;

10. Standard on Automatic Fire Detectors, NFPA No. 72E-1987;

11. Standard for Fire Doors and Windows, NFPA No. 80-1990; and

12. Standard for Tank Vehicles for Flammable and Combustible Liquids, NFPA No. 385-1990.

(h) National Leak Prevention Association, (NLPA), 7685 Fields Ertel Road, Cincinnati, Ohio 45241.

1. Spill Prevention, Minimum 10-year Life Extension of Existing Steel Underground Storage Tanks by Lining Without the Addition of Cathodic Protection, NLPA Standard 631, Second Edition, 1988; and

2. Internal Inspection of Steel Tanks for Upgrading With Cathodic Protection Without Internal Lining, NLPA Standard 632, Draft January 1989.

(i) Petroleum Equipment Institute, (PEI), P.O. Box 2380, Tulsa, Oklahoma 74101, Recommended Practices for Installation of Underground Liquid Storage Systems, PEI Publication RP100-90, 1990.

(j) Steel Tank Institute, 570 Oakwood Road, Lake Zurich, Illinois 60047.

1. Specification for STI-P<sub>3</sub>® System of External Corrosion Protection of Underground Steel Storage Tanks, 1990;

2. Standard for Dual Wall Underground Steel Storage Tanks, STI F841-88;

3. Recommended Practice for Corrosion Protection of Underground Piping Networks Associated with Liquid Storage and Dispensing Systems, STI R892-89; and

4. Specification for External Corrosion Protection of FRP Composite Steel Underground Storage Tanks, STI F894-90.

(k) Underwriters Laboratories Inc. (UL), 333 North Pfingsten Road, Northbrook, Illinois 60062.

1. Steel Underground Tanks for Flammable and Combustible Liquids, UL Standard 58 - 1985, 8th Edition with 4/86 Revisions;



2. Standard for Steel Inside Tanks for Oil-Burner Fuel, UL Standard 80 -1980 (R1985);

3. Standard for Steel Aboveground Tanks for Flammable and Combustible Liquids, UL Standard 142 - 1987 6th Edition with 9/87 Revisions;

4. Pipe Connectors for Flammable and Combustible Liquids and LP-Gas, UL Standard 567 - 1989;

5. Outline of Proposed Investigation for Nonmetallic Underground Piping for Petroleum Products, UL Subject 971;

6. Glass-Fiber Reinforced Plastic Underground Storage Tanks for Petroleum Products, UL Standard 1316 - 1986; and

7. Corrosion Protection Systems for Underground Storage Tanks, UL Standard 1746 - 1989.

(1) Underwriters Laboratories of Canada, General Offices and Testing Station, 7 Crouse Road, Scarborough, Ontario M1R 3A9.

1. Standard for Galvanic Corrosion Protection Systems for Underground Tanks for Flammable and Combustible Liquids, UL CAN 4-S603.1-M85;

2. Standard for Steel Underground Tanks for Flammable and Combustible Liquids, UL CAN 4-S603-M85;

3. Standard for Isolation Bushings for Steel Underground Tanks Protected with Coatings and Galvanic Systems, UL CAN 4-S631-M84;

4. Standard for Reinforced Plastic Underground Tanks for Petroleum Products, UL CAN 4-S615-M83;

5. Guide for Glass Fiber Reinforced Plastic Pipe and Fittings for Flammable Liquids, ULC subject C107C - M1984; and

6. Flexible Underground Hose Connectors for Flammable and Combustible Liquids, UL CAN 4-S633-M84.

(2) INTERIM AMENDMENTS. Interim amendments of the standards shall have no effect in the state until such time as this section is correspondingly revised to reflect those changes.

(3) AVAILABILITY OF STANDARDS. Copies of the standards in reference are available from the associations at the addresses listed in sub. (1).

(4) FILING OF STANDARDS. Copies of the standards in reference are on file in the offices of the department, the secretary of state and the revisor of statutes.

ILHR 10.26 SECONDARY REFERENCES. For the purposes of this chapter, the department will enforce the applicable provisions of the following Wisconsin Administrative Codes where the indicated national standards are referenced in the adopted NFPA standards.

(1) BOILER AND PRESSURE VESSELS. Chapters ILHR 41-42 in lieu of the American Society of Mechanical Engineers (ASME) Boiler and Pressure Vessel Code.

(2) BUILDING CODE. Chapters ILHR 50-64 in lieu of the following National Fire Protection Association (NFPA) standards:

(a) NFPA No. 14 - Standard for the Installation of Standpipe and Hose Systems.

(b) NFPA No. 24 - Standard for Outside Protection.

(c) NFPA No. 80 - Standard for Fire Doors and Windows.

(d) NFPA No. 101 - Life Safety Code.

(e) NFPA No. 220 - Standard Types of Building Construction.

(f) NFPA NO. 251 - Standard Methods of Fire Tests of Building Construction and Materials.

(3) ELECTRICAL CODE. Chapter ILHR 16 in lieu of National Fire Protection Association (NFPA) Standard No. 70 - National Electrical Code.

ILHR 10.27 CONSTRUCTION, INSTALLATION, OPERATION AND MAINTENANCE OF FLAMMABLE AND COMBUSTIBLE LIQUID FACILITIES. Except as otherwise provided in this chapter, all flammable and combustible liquid facilities shall be designed, constructed, installed, operated and maintained as specified in the following standards, as applicable to the facility, adopted in s. ILHR 10.25:

(1) AMERICAN PETROLEUM INSTITUTE. American Petroleum Institute (API) Publications 1604, 1615, 1621, 1631, 1632, 2015 and 2200, and Standard 650;

(2) AMERICAN NATIONAL STANDARDS INSTITUTE. American National Standards Institute (ANSI), ANSI/ASME Standards B31.3, B31.4 and B36.10M;

(3) AMERICAN SOCIETY FOR TESTING AND MATERIALS. American Society for Testing and Materials (ASTM) Standards, D5, D56, D86, D93, D323, D3278, D3828, and D4021;

(4) ASSOCIATION FOR COMPOSITE TANKS. Association for Composite Tanks (ACT) Standard ACT-100;

(5) NATIONAL ASSOCIATION OF CORROSION ENGINEERS. National Association of Corrosion Engineers (NACE) Standards RP-01-69 and RP-02-85;

(6) NATIONAL FIRE PROTECTION ASSOCIATION. National Fire Protection Association (NFPA) Standards 13, 17, 30, 30A, 33, 34, 35, 37, 45, 72E, 80, and 385;

(7) NATIONAL LEAK PREVENTION ASSOCIATION. National Leak Prevention Association (NLPA) Standards 631 and 632;

(8) PETROLEUM EQUIPMENT INSTITUTE. Petroleum Equipment Institute (PEI) Standard RP 100;

(9) STEEL TANK INSTITUTE. Steel Tank Institute (STI) Specification STI-P<sub>3</sub>®, Guideline for Underground Piping for Fuel Storage Tanks and Standards STI F841, STI R892 and STI F894;

(10) UNDERWRITERS LABORATORIES INC. Underwriters Laboratories (UL) Standards 58, 80, 142, 567, 1316 and 1746, and subject 971; and

(11) UNDERWRITERS LABORATORIES OF CANADA. Underwriters Laboratories of Canada (UL CAN) Standards UL CAN 4-S603.1-M85, 4-S603-M85, 4-S631-M84, 4-S615-M83, Subject C107C-M84 and 4-S633-M84.

## SUBCHAPTER V - GENERAL REQUIREMENTS FOR FIRE PREVENTION AND PROTECTION

### PART 1 - MISCELLANEOUS APPLICATIONS

ILHR 10.28 GENERAL PROVISIONS FOR SALE, PURCHASE, DISPENSING OR USE OF FLAMMABLE AND COMBUSTIBLE LIQUIDS. (1) LABELING. No sale or purchase of any Class I, II or III liquid may be made in containers, unless such containers are clearly marked with the name of the product.

(2) CONTAINERS. (a) A Class I flammable liquid when used in starting an engine or as fuel for a small heating appliance, lighting appliance, power tool or gasoline engine shall be dispensed only from an approved, properly identified safety can or screwed cover spout can approved for that specific use.

(b) No dispensing of any liquids having a flash point of less than 100°F may be made into portable containers or portable tanks unless such container or tank is substantially a bright red color. The container shall also be either listed or classified by Underwriters Laboratories (UL).

(c) No kerosene, fuel oil or similar liquids having a flash point of 100°F or more may be filled into any portable container or portable tank colored red.

Note: See s. 168.11, Stats., for additional requirements.

(3) REPAIR AND MAINTENANCE, SOURCES OF IGNITION. Repair and maintenance work involving a possible source of ignition shall not be performed in a room or area containing or likely to contain an ignitable mixture of hydrocarbon vapors and air.

(4) DEGREASING AND CLEANING. (a) Except as provided in par. (b), a Class I flammable liquid shall not be used for degreasing or cleaning any engine, machine, equipment or part thereof, or for cleaning a floor, pit, or any part of a building or premises:

(b) Industrial processes requiring use of Class I flammable liquids for degreasing or cleaning any engine, machine or part shall be designed to incorporate a ventilation system to reduce and maintain vapor concentration to less than 25% of the lower explosive limit. The interior of closed vessels may be cleaned with Class I flammable liquids in an inert atmosphere as specified in s. 9-3 of NFPA 35.

(5) SATURATED CLOTHING. Clothing saturated with a Class I or II liquid shall not be worn longer than the time required for removal and shall not be worn or taken into a building where a source of ignition exists.

(6) DISPENSING FROM TANK VEHICLE TO SUPPLY TANK. Class I flammable liquids shall not be dispensed from a tank vehicle into the fuel supply tank of the internal combustion engine for the tank vehicle.

ILHR 10.29 RACE TRACK FUELING STATIONS. Tanks of racing vehicles shall be filled from safety cans, fixed pumping facilities or from properly mounted contractor tanks designed in accordance with s. ILHR 10.32. During a race in which a vehicle is competing, the vehicle may be refueled while its engine is running. Signs prohibiting smoking in fueling areas shall be posted and an approved fire extinguisher of at least 20 B:C classification shall be provided at each fueling location.

ILHR 10.30 MOTOR VEHICLE EXHIBITION. Vehicles with internal combustion engines may be exhibited in buildings, other than in those where the vehicles are normally serviced or sold or both, provided the following requirements are satisfied:

(1) AREA SPECIFIED. A specific area shall be designated for display of the vehicles.

(2) EXITS. The vehicles shall not be displayed in any required passageway, corridor or exit way leading to an exit.

(3) RUNNING OF ENGINES. The vehicle engine shall not be started or run, except that the vehicle may be driven in and out of the building under its own power but only when the building is not occupied by the general public.

(4) FUEL IN TANKS. The fuel supply in tanks shall be limited to not more than 5 gallons of fuel per vehicle when entering the building.

(5) DRAINING OF FUEL. When it is necessary to drain the excess fuel from the tank, the draining operation shall take place outside of the building.

(6) FUEL TANK CAP SECUREMENT. The fill cap shall be of a lock type or the cap shall be securely taped with a material that is not soluble in a petroleum fuel.

(7) BATTERY. The grounding cable shall be disconnected from the battery terminal. The grounding cable and exposed battery terminal shall be completely covered with tape to be electrically insulated.

(8) CARBURETOR. The throttle linkage to the carburetor shall be disconnected or the accelerator shall be blocked so that it cannot be depressed.

(9) ATTENDED OR UNATTENDED EXHIBITION. When the exhibition is unattended, the vehicle doors shall be locked.

(10) FIRE EXTINGUISHER. One approved hand fire extinguisher of at least a 20 B:C rating shall be located within 75 feet travel distance of any displayed vehicle.

(11) FIRE DEPARTMENT NOTIFICATION. The local fire department shall be notified in writing 5 days in advance of the date the vehicle is to be displayed.

(12) INSPECTION. The local fire department having jurisdiction shall inspect the vehicles before the general public is permitted to occupy the building.

(13) SMOKING PROHIBITED. (a) Smoking shall not be permitted in the posted vicinity of the vehicles being displayed.

(b) "No Smoking" signs shall be posted in the vicinity of the vehicle display.

ILHR 10.31 FUELING OF MOTOR VEHICLES. (1) GENERAL. (a) The fueling of motor vehicles shall be in accordance with the provisions of NFPA Standards 30 and 30A as adopted in s. ILHR 10.25 unless otherwise specified in this chapter.

(b) Emergency fueling of a motor vehicle from a portable container is allowed only with a container not exceeding 5-gallon capacity.

(2) APPLICATION. The provisions of this section shall apply to all fueling facilities in existence on the effective date of this chapter and to facilities constructed after the effective date.

ILHR 10.32 VEHICLE-MOUNTED CONTRACTOR TANKS AND VEHICLE-MOUNTED FARM FUEL TANKS. Vehicle-mounted contractor tanks and vehicle-mounted farm fuel tanks shall conform to the requirements illustrated in Figures 10.32-1 to 10.32-3 and with the following:

(1) TANK DESIGN. (a) Tanks shall be constructed of a minimum of 14 gauge steel with arc welded seams.

(b) Baffles shall be installed in tanks having a capacity in excess of 100 gallons.

(c) Capacity of tanks shall be limited to 200 gallons.

(2) TANK COLOR AND LABELS. (a) Tanks or compartments storing gasoline shall be substantially a bright red color and labeled "gasoline."

(b) Tanks or compartments storing diesel fuel or fuel oil shall be substantially yellow in color and labeled "diesel fuel" or "fuel oil."

(3) STOPS AND ANCHORS. Stops and anchors shall be provided and attached to the vehicle to prevent movement of the tank.

(4) DISPENSING PUMPS. The tank shall be equipped with approved pumps for dispensing.

(5) FILL CAP AND VENT. Each compartment shall be equipped with a 2-inch approved combination fill cap and vent (anti-spill type cap).

(6) MULTIPLE COMPARTMENT TANKS. If a compartment of a tank holding Class I liquids is adjacent to a compartment holding Class II or Class III liquids, an air space between the compartments shall be provided. A drain shall be provided in the space between the compartments and it shall be maintained in an operative condition.

(7) DEPARTMENT OF TRANSPORTATION (D.O.T.) DRUMS. The use of D.O.T. drums shall be prohibited.

(8) APPLICATION. The provisions of this section shall apply to all units in existence on the effective date of this chapter and to units constructed after the effective date.

Figure 10.32-1  
100 Gallon Utility Tank

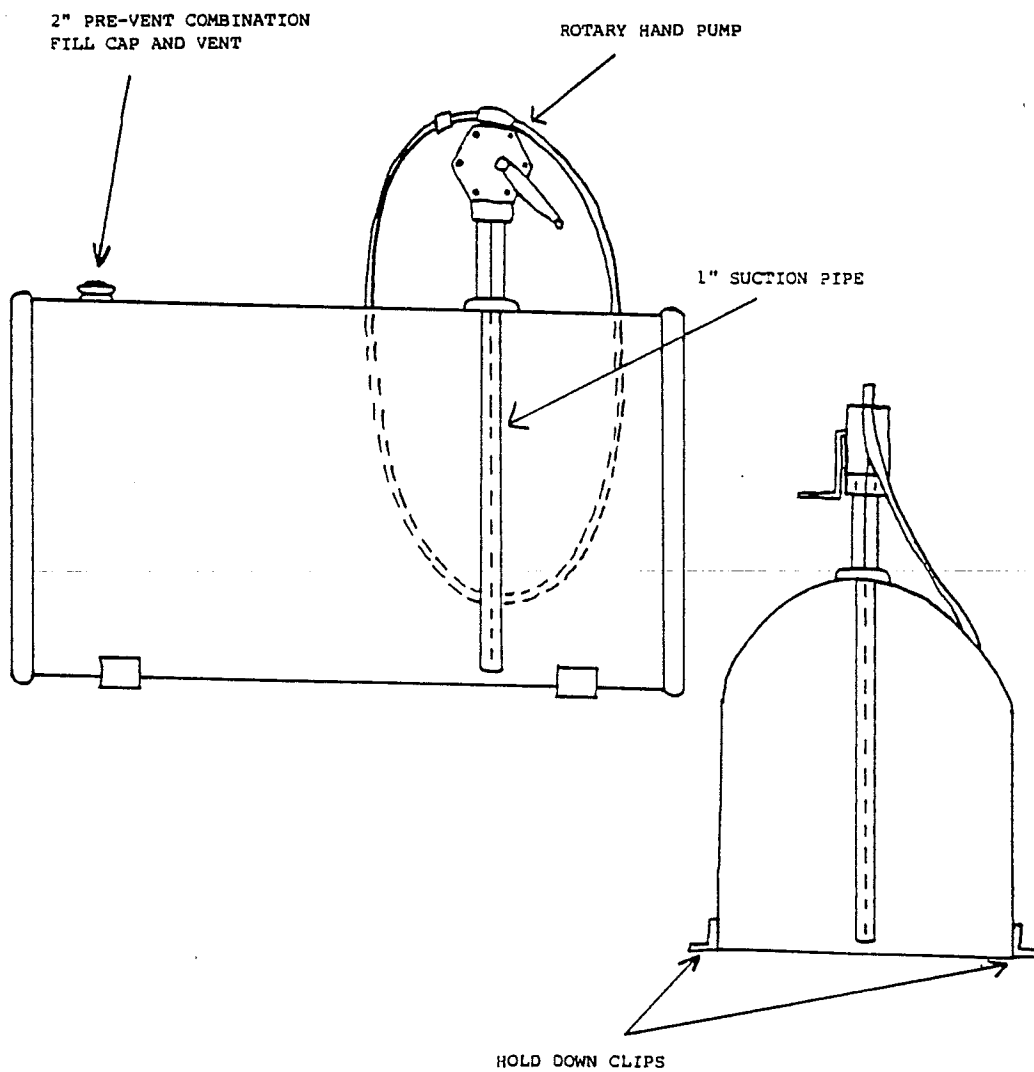

Figure 10.32-2  
200 Gallon Skid Tank with Baffle

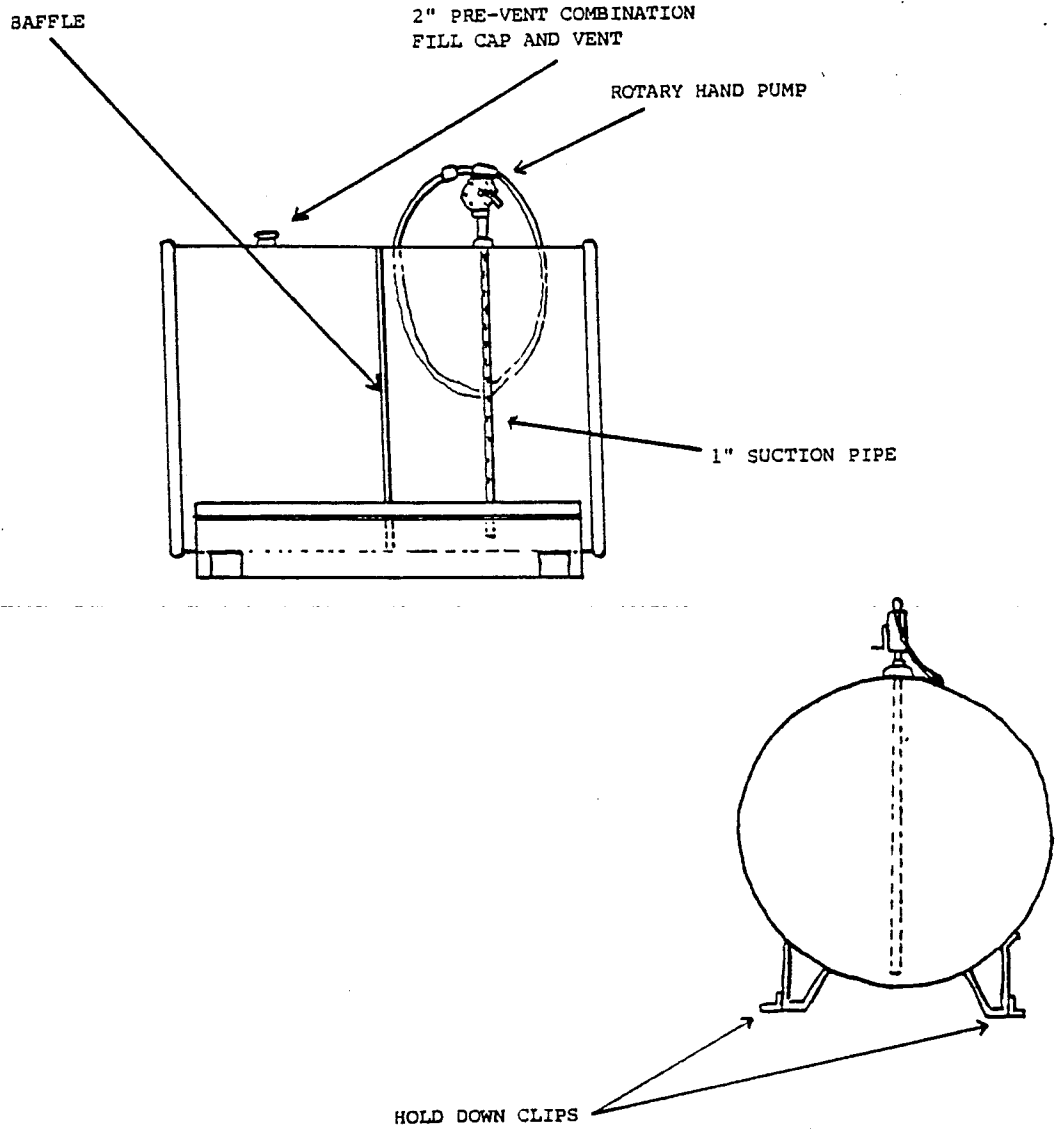
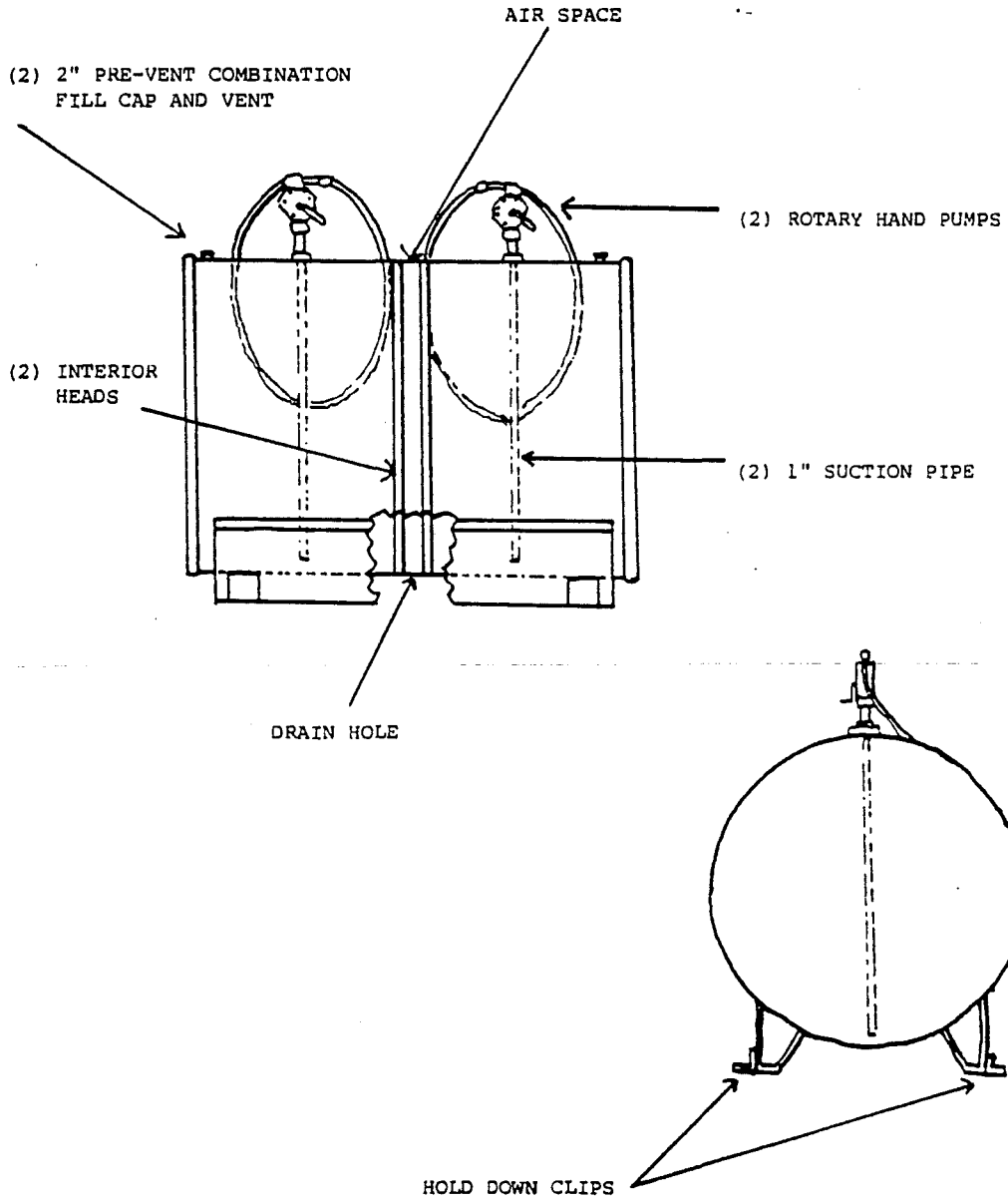



Figure 10.32-3  
200 Gallon Two Compartment Skid Tank



ILHR 10.33 WASTE OIL COLLECTION POINTS. (1) ABOVEGROUND TANKS. (a) General. All new and replacement aboveground waste oil collection points shall comply with the requirements of this section.

Note: Also see ch. NR 183 for additional rules pertaining to waste oil collection points.

(b) Tank size and construction. 1. The tank may be of any size. Tanks located outside and exceeding 1000 gallons in capacity shall be located at least 20 feet from any building or combustible structure.

2. The tank shall be equipped with an approved vent pipe and fill opening. The vent pipe size shall be calculated in accordance with Section 2-2.4.2 of NFPA Standard 30 as it applies to Class I liquid storage.

3. The fill opening shall be located in a waterproof enclosure of noncombustible construction and shall be screened to prevent the passage of solid objects into the tank.

(c) Diked area. The tank shall be placed in the center of a dike that conforms to s. ILHR 10.345 (1). The fill opening shall be located within the diked area.

(d) Signage. 1. A permanent sign, of durable material, shall be installed at the waste oil collection point.

2. The sign shall include the following:

"NOTICE - WASTE OIL COLLECTION ONLY"

"NO SMOKING"

(e) Vehicle collision protection. Vehicle collision protection shall be provided in accordance with s. ILHR 10.415 (8).

(2) UNDERGROUND TANKS. (a) All new and replacement underground waste oil collection points shall comply with the applicable portions of ch. 2 of NFPA Standard 30 and subch. VI for underground tanks, including provisions for groundwater protection.

(b) The fill opening to the tank shall comply with sub. (1) (b) 3.

Note: See s. 144.64, Stats., for additional information.

ILHR 10.335 USED INTERNAL COMBUSTION ENGINE CRANKCASE OIL. (1) CLASSIFICATION. Used internal combustion engine crankcase oil shall be stored, handled, transferred and used in accordance with the requirements of this code for Class I liquids unless testing indicates that a different classification is applicable. Testing shall be performed on a batch-wise basis in accordance with closed cup test methods specified in s. ILHR 10.25 (1)(c). Test results shall be maintained on site and available for inspection upon request.

(2) STORAGE INSIDE BUILDINGS. Used internal combustion engine crankcase oil may be stored in tanks inside buildings in areas at or above grade in accordance with this section.

(a) Tanks larger than 60 gallons capacity shall be located in buildings at the lowest story, cellar or basement, except in industrial or processing plants where storage on a higher floor is required by the process.

(b) Tanks or barrels with individual capacity of more than 300 gallons but of 660 gallons or less and with aggregate capacity of 1,320 gallons or less, shall be located in an enclosure as required by s. ILHR 59.21. Doors of the enclosure shall be protected by liquid-tight sills or ramps capable of containing the largest likely spill or a drainage system to a remote tank or catchbasin shall be provided.

(c) Tanks exceeding 660 gallons individual capacity or exceeding 1,320 gallons aggregate capacity in an individual building or in a section of a building separated by fire walls shall be installed in an enclosure constructed as follows:

1. Floors, walls and ceilings of 4-hour fire-resistive rated construction;

2. Walls bonded to floor and ceiling; and

3. Openings protected by 3-hour labeled fire door assemblies and liquid-tight sills or ramps capable of containing the largest likely spill or a drainage system to a remote tank or catchbasin shall be provided.

(d) 1. The nominal gross capacity of tanks located in buildings of types one and two fire-resistive construction shall not exceed 15,000 gallons.

2. The nominal gross capacity of tanks located in buildings of type 5-exterior masonry, or type 6-metal frame unprotected construction as specified in s. ILHR 51.03 shall not exceed 10,000 gallons.

3. The nominal gross capacity of tanks located in buildings of any class of construction shall not exceed 50,000 gallons, with an individual tank capacity not exceeding 25,000 gallons provided such tanks are located in a 2-hour rated fire-resistive or detached room and are cut off both vertically and horizontally from the remainder of the building in a manner acceptable to the department or its authorized deputy.

(e) Buildings in which tanks of more than 300 gallons capacity are located shall be protected by an automatic fire detection system which is designed, installed and maintained in accordance with the provisions of NFPA Standard 72E as adopted in s. ILHR 10.26 (2).

(f) Where tank enclosures are required under pars. (b) or (c), a dry chemical suppression system shall be designed to totally flood the tank enclosure. The fire suppression system shall be designed, installed and maintained in accordance with NFPA Standard 17, as adopted in s. ILHR 10.26 (2).

(g) Where tank enclosures are required under pars. (b) or (c), doors protecting the tank enclosure shall normally be kept closed or shall be held open with automatic hold-open devices designed to close the door upon activation of the dry chemical suppression system.

(h) Tank enclosures required under pars. (b) or (c) shall not be used for purposes other than flammable and combustible liquid storage.

(i) The design, construction and venting of tanks for storage inside buildings of used internal engine crankcase oil shall comply with sections 2-4.2 to 2-4.4 of NFPA Standard 30 as it is applied to Class I liquid storage. The bottom of tanks shall be no more than 36 inches above the floor. Vents shall terminate outside the building.

## PART 2 - TANK STORAGE

ILHR 10.34 TANKS USED AS PRESSURE VESSELS. Tanks used as pressure vessels shall be constructed of steel and shall comply with the applicable provisions of chs. ILHR 41-42.

ILHR 10.342 LOCATION OF NEW AND REPLACEMENT UNDERGROUND STORAGE TANKS. All new and replacement underground storage tanks shall be located to provide a separation from a water well or reservoir as specified in s. NR 112.07 (k).

Note: Section NR 112.07 (k) specifies that the separating distance shall be "One hundred feet between well or reservoir and bulk subsurface storage tanks for refined petroleum products such as gasoline and fuel oil, except in the case of fuel oil tanks for private residential use, in which case the separating distance shall be at least 25 feet or farther where practical."

ILHR 10.345 IMPOUNDING AROUND OUTSIDE ABOVEGROUND STORAGE TANKS BY DIKING. (1) NEW AND REPLACEMENT TANKS. In addition to the requirements specified in s. 2-2.3.3 of NFPA Standard 30, dike systems for new and replacement outside aboveground storage tanks shall comply with this subsection.

(a) The capacity of the dike system shall be 25% larger than required by s. 2-2.3.3 (b) of NFPA Standard 30.

(b) The dike system shall have provisions for the removal of rainwater. Drainage systems which breach the dike shall have self-closing valves. *Per DILHC 1/25/71*

(c) The walls and floor of the diking system shall be designed to withstand all foreseeable loading conditions including the tank load and the full hydrostatic head of any discharged liquid.

(d) The walls of the dike system shall be constructed of earth, steel, concrete or solid masonry. All cracks, seams and joints shall be sealed to be liquid-tight.

(e) Dike walls and floors made of earth or other permeable materials shall be lined with asphalt, concrete, a synthetic or manufactured liner, or a prefabricated basin to create a barrier impervious to the stored product. Liners covering the floor of the dike shall protect the undertank area.

1. Asphalt and concrete liners shall have all cracks, seams and joints sealed to prevent leakage.

2. Synthetic liners shall have a minimum thickness of 60 mils and be chemically compatible with the stored product. Synthetic liners shall be protected by a 6 inch soil layer below the liner and a 12 inch soil layer above the liner. Both soil layers shall be free of large rocks, angular stones, sticks or other materials which may puncture the liner. Synthetic liners shall be installed under the supervision of a qualified representative of the manufacturer and all field-constructed seams shall be tested and repaired, if necessary, in accordance with the manufacturers recommendations.

3. Except for asphalt and concrete liners, liners used under aboveground storage tanks for compliance with this section, shall be approved by the department for that specific type of application in accordance with s. ILHR 10.125.

4. Prefabricated basins shall have floors and walls constructed of steel or rigid synthetic materials which are resistant to corrosion, puncture and cracking. Materials used in the basin shall be chemically compatible with the stored product. A written confirmation of the compatibility from the basin manufacturer shall be retained at the storage facility or at the nearest local office from which the storage facility is administered. If multiple basins are connected to provide the capacity required under par. (b), the basins shall be connected in a manner which assures unrestricted transfer of product between basins.

(2) EXISTING TANKS. Aboveground outside storage tanks which exceed 5,000 gallons capacity and which were installed prior to the effective date of this chapter shall be brought into compliance with either par. (a), (b), (c) or (d) within 10 years of the effective date of this chapter.

(a) The tanks shall be provided with a dike system that complies with section 2-2.3.3 of NFPA Standard 30 and s. ILHR 10.345 (1)(c) to (e) and either 25% extra capacity or provisions for the removal of rainwater as specified in s. ILHR 10.345 (1)(a) or (b).

(b) The tanks shall be provided with an automatic release detection system designed and installed in accordance with s. ILHR 10.61 capable of detecting releases in the soil underneath and adjacent to the tanks; or

(c) The tanks shall be lined and inspected periodically in accordance with ILHR 10.52 (2)(a). The lining shall be applied to the bottom of the tank and up the tank sides from the bottom to at least 2 feet above exterior grade level.

(d) The tanks shall be provided with secondary containment in the form of a second bottom.

1. A second bottom constructed for a storage container shall be made of steel. The department may also approve a second bottom made of other materials if the materials, considering the substances held in the storage container, provide protection for the waters of the state that is substantially similar to the protection provided by a liner described in sub. (1). Any request for departmental approval shall be supported by a plan, certified by a registered engineer, showing that the proposed use of other materials will provide this protection.

2. The original bottom of the storage container shall be tested for leaks before the sand layer or second bottom are installed. A record of the test shall be kept on file at the storage facility.

3. The newly constructed bottom shall be tested for leaks before any product is stored on the newly constructed bottom. A record of the test shall be kept on file at the storage facility, or at the nearest local office from which the storage facility is administered.

4. The interstitial space between the primary and secondary containment shall be provided with an automatic release detection system or with means for visual inspection.

ILHR 10.35 ABOVEGROUND TANK LABELS. Aboveground tanks for Class I liquids, other than at refineries, or marine, pipeline or transport terminals or waste oil storage facilities shall have painted conspicuously thereon in letters of a contrasting color at least 5 inches high with a minimum stroke width of one inch, the wording "FLAMMABLE - KEEP FIRE AWAY".

ILHR 10.355 ABOVEGROUND TANK-DESIGN. Tanks that are used for aboveground storage shall be listed for aboveground use. Tanks designed and built for underground use shall not be installed for aboveground use.

ILHR 10.36 CLOSURE OF ABOVEGROUND TANKS. (1) TEMPORARY CLOSURE. (a) When an aboveground storage tank system is temporarily closed, owners and operators shall continue operation and maintenance of any corrosion protection or release detection systems. Parts 5 and 6 of Subchapter VI shall be complied with if a release is suspected or confirmed. However, the operation and maintenance of a release detection system is not required as long as the aboveground tank system is empty. The tank system is empty when all materials have been removed using commonly employed practices so that no more than one inch of residue, or 0.3% by weight of the total capacity of the tank system, whichever is less, remains in the system.

(b) When an aboveground tank system is temporarily closed for 3 months or more, owners and operators shall also comply with the following requirements:

1. Leave vent lines open and functioning; and
2. Cap and secure all other lines, pumps, manways, and ancillary equipment.

(c) When an aboveground storage tank system is temporarily closed for more than 12 months, owners and operators shall permanently close the system in accordance with sub. (3) unless the department provides an extension of the 12-month temporary closure period in writing.

(2) SELDOM USED TANKS. Except for oil tanks used for emergency and backup fuel or overflow tanks, tank systems shall be considered to be abandoned and therefore subject to closure in accordance with sub. (1) or sub. (3) unless product transfers are made to or from the system periodically.

(a) Transfers shall be made to and from motor fuel tanks at least once in any 180-day period to be considered in use.

(b) Transfers shall be made to and from heating oil tanks at least once in any 1-year period to be considered in use.

(c) Inventory records, manifests, or paid receipts for product received will be acceptable to the department as proof that transfers are being made.

(d) Tank system owners and operators may make written requests to the department for approval for less frequent use if it is justified as a part of the tank's purpose.

(3) PERMANENT CLOSURE AND CHANGES-IN-SERVICE. At least 30 days before beginning either permanent closure or a change-in-service or within another reasonable time period determined by the department, owners and operators shall notify the authorized agent of their intent to permanently close or make the change-in-service, unless such action is in response to corrective action.

(a) To permanently close an aboveground storage tank system, owners and operators shall empty and clean it by removing all liquids and accumulated sludges in accordance with the procedures specified in API Publication 2015--Cleaning Petroleum Storage Tanks. Tanks shall be inerted so that the composition of the atmosphere inside the tank is 10% of the lower explosive limit for the stored product prior to performing any other work on the tank. Cleaning of the tank shall be performed by a certified cleaner. If removed, removal of tanks and other portions of storage tank systems shall be performed by a certified remover.

(b) Continued use of an aboveground storage tank system to store a nonregulated substance is considered a change-in-service. Before a change-in-service, owners and operators shall empty and clean the tank by removing all liquid and accumulated sludge in accordance with the procedures specified in API Publication 2015--Cleaning Petroleum Storage Tanks. Cleaning of tanks shall be performed by persons certified by the department to do such work.

(c) Parts 5 and 6 of Subchapter VI shall be complied with if a release is suspected or confirmed.

### PART 3 - BULK PLANTS AND TERMINALS

ILHR 10.37 LESSER CLEARANCES AT EXISTING BULK PLANTS PERMITTED. (1) Existing bulk plant facilities with clearances less than those specified in s. 5-3 of NFPA Standard 30 may be renovated or updated, but no additional storage capacity shall be permitted in violation of those specified clearances.

(2) (a) Each connection to a tank inside of buildings through which liquid can normally flow shall be provided with an internal or an external valve located as close as practical to the shell of the tank.

(b) External valves and their connections to the tank shall be of steel except when the chemical characteristics of the liquid stored are incompatible with steel.

(c) When materials other than steel are necessary, they shall be suitable for the pressures, structural stresses and temperatures involved, including fire exposures.

(3) (a) Except as provided in par. (b), flammable or combustible liquid tanks located inside of buildings shall be provided with an automatic closing heat-actuated valve on each withdrawal connection below the liquid level to prevent continued flow in the event of fire in the vicinity of the tank.

(b) 1. Connections for emergency disposal need not comply with par. (a).

2. Flammable or combustible liquid tanks in one-story buildings designed and protected for flammable or combustible liquid storage need not comply with par. (a).

(4) Valves specified in sub. (3) shall be incorporated in the valves required by sub. (2), or shall be located adjacent to the valves required by sub. (2).

(5) Manual openings, if independent of the fill pipe, shall be provided with a vapor-tight cap or cover. Each opening shall be protected against liquid overflow and possible vapor release by means of a spring loaded check valve or other approved device.

(6) For Class IB and Class IC liquids other than crude oils and asphalts, the fill pipe shall be so designed and installed as to minimize the possibility of generating static electricity by terminating within 6 inches of the bottom of the tank.

(7) The fill pipe inside of the tank shall be installed to avoid excessive vibration of the pipe.

(8) The inlet of the fill pipe shall be located outside of buildings at a location free from any source of ignition and not less than 5 feet away from any building opening. The inlet of the fill pipe shall be closed and liquid-tight when not in use. The fill connection shall be properly identified. The fill pipe shall be removed when the tank is disconnected or removed.

(9) Tanks inside buildings shall be equipped with a device, or other means shall be provided, to prevent overflow into the building.

(10) Inside storage tanks for Class III combustible liquids shall be provided with draw-off or drain openings. Tanks shall be installed so that the bottom pitches to the draw-off or drain openings at a slope of not less than 1/4 inch per foot of length. The draw-off or drain opening shall be provided with suitable connection to provide a sump from which water or sediment can be readily drained.



ILHR 10.38 BULK PLANT PRODUCT COLOR CODING. (1) STANDARD COLOR CODE. All piping at bulk plants shall be identified by the following standard color coding:

- (a) Leaded gasoline:
  - 1. Highest Octane . . . . . Red circle with the word "Gas"
  - 2. Mid-grade Octane . . . . . Blue circle with the word "Gas"
  - 3. Lowest Octane . . . . . White circle with the word "Gas"
- (b) Unleaded gasoline:
  - 1. Highest Octane . . . . . Red circle with white cross and the word "Gas"
  - 2. Mid-grade Octane . . . . . Blue circle with white cross and the word "Gas"
  - 3. Lowest Octane . . . . . White circle with black cross and the word "Gas"
- (c) Diesel Fuel . . . . . Yellow hexagon with the word "Diesel"
- (d) #1 Fuel Oil . . . . . Purple hexagon with yellow stripe and the words "#1 Oil"
- (e) #2 Fuel Oil . . . . . Green hexagon with the words "#2 Oil"
- (f) Kerosene . . . . . Brown hexagon with the word "Kerosene"
- (g) Products containing extenders such as ethanol shall be designated by the addition of a boarder around the symbol: black around white symbols and white around other color symbols. Gasohol shall be designated with the word "Gasohol" as well.
- (h) Vapor recovery connections and manholes shall be marked with orange circles and the word "Vapor".
- (i) Observation and monitoring wells shall be marked with a black triangle on a white background. The well shall be provided with a durable label warning against the accidental or intentional introduction of petroleum products into the well.

(2) TYPE OF IDENTIFICATION. The product identification shall be accomplished by the use of a disc type tag of nonsparking material, not less than 6 inches diameter bearing the color code and the name of the product.

(3) LOCATION OF IDENTIFICATION. Tags shall be permanently affixed to the valve at the unloading riser, the pump control valves, the valve of a storage tank and load rack and on the product pipe lines in at least 3 locations equally spaced between terminating points or valves.

ILHR 10.39 CARE AND ATTENDANCE OF PROPERTY. Plant and tank yards shall be kept free from weeds, high grass, rubbish and litter, and shall be kept neat, clean and orderly throughout.

PART 4 - SERVICE STATIONS

ILHR 10.395 OVERFILL PROTECTION. Prior to the delivery of product to a bulk tank, the driver, operator, or attendant of the tank vehicle shall measure the available capacity of the tank to which product is to be delivered. The available capacity shall be more than the volume of the product to be delivered.

ILHR 10.40 SEPARATION AND COLOR CODING OF DISPENSING EQUIPMENT. (1) EXISTING EQUIPMENT. (a) No kerosene may be dispensed from multiple nozzle dispensing equipment where flammable liquids are also dispensed.

(b) Dispenser nozzles which deliver diesel fuel shall be color coded yellow.

(c) Within 1-year of the effective date of the rules existing equipment at service stations shall comply with pars. (a) and (b). All existing equipment at service stations shall comply with the requirements of sub. (2) within 5 years after the effective date of this chapter.

Note: The effective date of this chapter is [Revisor insert date].

(2) NEW EQUIPMENT. New and replacement dispensing equipment shall comply with this subsection.

(a) Dispensing equipment for kerosene shall be placed at least 10 feet away from dispensing equipment for Class I liquids.

(b) Dispenser nozzles which deliver diesel fuel shall be color coded yellow.

(3) CHANGE IN PRODUCT. When the product dispensed from a tank system is changed from a Class I liquid to a Class II or Class III liquid, the local petroleum inspector shall be notified and the product tested and approved prior to dispensing any of the new product.

ILHR 10.41 SERVICE STATION PRODUCT COLOR CODING. (1) STANDARD COLOR CODE. All fuel tank fill pipe caps and manhole covers shall be identified by the following standard color and symbol coding:

(a) Leaded gasoline:

- 1. Highest Octane . . . . . Red circle
- 2. Mid-grade Octane . . . . . Blue circle
- 3. Lowest Octane . . . . . White circle

(b) Unleaded gasoline:

- 1. Highest Octane . . . . . Red circle with white cross
- 2. Mid-grade Octane . . . . . Blue circle with white cross

- 3. Lowest Octane . . . . . White circle with black cross
- (c) Diesel Fuel . . . . . Yellow hexagon
- (d) #1 Fuel Oil . . . . . Purple hexagon with yellow stripe
- (e) #2 Fuel Oil . . . . . Green hexagon
- (f) Kerosene . . . . . Brown hexagon

(g) Products containing extenders such as ethanol shall be designated by the addition of a boarder around the symbol: black around white symbols and white around other color symbols.

(h) Vapor recovery connections and manholes shall be marked with orange circles.

(i) Observation and monitoring wells shall be marked with a black triangle on a white background. The well shall be provided with a durable label warning against the accidental or intentional introduction of petroleum products into the well.

(2) LOCATION OF IDENTIFICATION. (a) The entire fill pipe cap and manhole cover shall be color coded as specified in sub. (1). The color coding shall also extend at least 12 inches beyond the edge of the cap or cover on adjacent concrete or paving.

(b) If concrete or paving does not exist adjacent to the cap or cover, the cap or cover shall be identified by a disc-type tag or nonsparking material, not less than 6 inches in diameter bearing the color code as specified in sub. (1) and the name of the product.

(3) EFFECTIVE DATE. All service stations shall comply with the requirements of this section within 180 days after the effective date of this chapter.

Note: The effective date of this chapter is [Revisor insert date].

ILHR 10.415 VEHICLE FUEL DISPENSING FROM ABOVEGROUND TANKS. (1) APPLICATION. (a) The storage of fuel for motor vehicles at service stations shall comply with ch. 2 of NFPA 30A, except that aboveground tank systems may be used at marinas, private airports that are registered with the federal government or department of transportation, and retail, commercial, industrial, and governmental establishments in accordance with this section. Aboveground tanks shall not be used for vehicle fueling at residences except as provided in s. ILHR 10.42 (3).

(b) Commercial and residential marine service stations shall also comply with s. ILHR 10.42.

(c) Tanks for motor fuels at farms and construction projects shall comply with part 5 of this subchapter.

(2) TANK DESIGN AND CONSTRUCTION. (a) The design, construction and installation of aboveground tanks for motor vehicle fueling shall comply with chapter 2 of NFPA 30 and this subsection.

(b) Tanks shall be listed for aboveground use. Tanks shall be placed on a properly engineered base and elevated at least 1 foot above the dike floor.

(3) TANK SIZE. Aboveground tanks for motor vehicle fueling shall be no larger than 10,000 gallons. The aggregate capacity of aboveground motor vehicle fuel tanks at any service station shall be no more than 30,000 gallons.

(4) LOCATION. (a) The setbacks specified in Table 10.415 shall be maintained between aboveground motor fuel tanks and buildings or property lines of property which could be built upon. The setback distances shall be measured from the inside of the dike wall or other secondary containment to the building or property line.

Table 10.415  
SETBACKS FOR ABOVEGROUND TANKS FOR  
MOTOR VEHICLE FUELING

| Capacity of All Tanks    | Setback Distance |
|--------------------------|------------------|
| 100 to 2,000 gallons     | 25 feet          |
| 2,001 to 10,000 gallons  | 50 feet          |
| 10,001 to 20,000 gallons | 75 feet          |
| 20,001 to 30,000 gallons | 100 feet         |

(b) 1. The setbacks specified in par. (a) may be reduced to a minimum of 15 feet if a 4-hour fire-rated wall is placed between the tank and the building or property line or both.

2. The setbacks specified in par. (a) may be reduced by 50% to a minimum of 25 feet if a 2-hour rated wall is placed between the tank and the building or property line or both.

3. Fire walls used for setback reduction shall extend laterally 3 feet beyond the tank and 3 feet above the tank or shall completely enclose the tank. The fire walls may be incorporated into a building described in sub. (5). The inside surface of a fire wall shall not be closer to a diked tank than the dike wall.

(c) There shall be a minimum of 3 feet between tanks.

(5) ABOVEGROUND TANK ENCLOSURES. (a) The area around an aboveground motor vehicle fuel tank and its secondary containment shall be secured by a 6-foot high noncombustible building or by a 6 foot high noncombustible fence with a gate. Gates or doors shall be normally locked. If the property on which the tanks are located has a perimeter security fence, additional enclosure of the tank and its secondary containment are not required.

(b) Buildings or fences for the enclosure of tanks shall be made entirely of noncombustible materials and have a minimum of one exit conforming to s. ILHR 51.15. Buildings constructed to comply with this subsection shall comply with ch. ILHR 53 and s. ILHR 51.15, but are otherwise exempt from the provisions of the Wisconsin Administrative Building and Heating, Ventilating and Air Conditioning Code, chs. ILHR 50 to 64. Buildings and fences shall not be supported by the tanks they enclose. Buildings or fenced enclosures shall not be used for occupancy, storage or any other use.

(c) Buildings for tank enclosure shall be ventilated. Ventilation may be provided by openings in outside walls. The openings shall be unobstructed except for louvers or course screens. Where natural ventilation is inadequate, mechanical ventilation shall be provided. Ventilation shall be a minimum of 150 cubic feet per minute, or 1 cubic foot per minute per square foot, whichever is greater. Exhaust air shall be taken from within 12 inches from the floor.

Note: A natural ventilation system incorporating a roof siphon ventilator ducted to take exhaust air from within 12 inches of the floor, assuming no more than 300 feet per minute vent duct air velocity and a separate make-up air inlet will be acceptable to the department.

(d) Fences surrounding tanks shall be of chainlink design or other open fencing approved by the department.

(e) Tank connections shall be piped or closed so that neither vapors nor liquid may escape inside the enclosure.

(f) All electrical equipment installed in enclosures or near tanks shall comply with chapter ILHR 16.

(6) BELOW-GRADE VAULTS. Tanks may be placed in below-grade vaults in accordance with this subsection.

(a) The walls, top, and floor of the vault shall be constructed of reinforced concrete at least 6 inches thick. The top shall be designed to withstand the anticipated loading. The walls and floor of any vault installed below grade shall be designed to withstand anticipated soil and hydrostatic loading. The vault shall be substantially liquid-tight and there shall be no backfill around the tank.

(b) The vault shall be protected from vehicle traffic in accordance with sub. (8).

(c) Vaults and tanks shall be suitably anchored to withstand uplifting by groundwater or flooding, including when the tank is empty.

(d) Each vault shall be equipped with a detection system that is capable of independently detecting both water and flammable or combustible liquids. The detection system shall be arranged to sound an alarm in the attended area of the service station and all dispensing of product shall automatically be shut off.

(e) Means shall be provided to ventilate each vault to dilute, disperse, and remove vapors. Ventilation shall be automatically activated upon detection of vapor. Ventilation shall comply with section 5-3.3 of NFPA Standard 30.

(f) Means shall be provided to recover liquid from the vault. If a pump is used to meet this requirement, the pump shall not be permanently installed in the vault. Portable pumps shall be suitable for use in Class I, Division 1 locations, as defined in chapter ILHR 16.

(g) Vent pipes that are provided for normal tank venting shall terminate at least 12 feet above ground level.

(h) Each vault shall be provided with a means for personnel entry. At each entry point, a warning sign indicating the need for procedures for safe entry into confined spaces shall be posted. A means of emergency egress shall be provided from the vault if the clear travel distance to the normal access point exceeds 50 feet. Each entry point shall be secure against unauthorized entry and vandalism.

(i) Each vault shall be provided with an approved means to admit a fire suppression agent, such as fire fighting foam, into the vault.

(j) The interior of any vault containing a tank that stores a Class I liquid shall be designated a Class I, Division 1 location, as defined by chapter ILHR 16.

(k) Pipe penetrations through the enclosure shall be located above the level of the highest tank. Pipes that penetrate the enclosures shall be sloped back to the tanks.

(l) Access for manual gauging of tanks may be provided by a hatch in the vault if secure against vandalism.

(m) No other items shall be stored in the vault. The vault shall not be used for any other purpose.

(n) Inspections of the vault interior and the vault's contents shall be made approximately one year after installation and at least once every five years thereafter. Inspections shall be made using applicable Occupational Safety and Health Administration (OSHA) procedures for entry into confined spaces.

(o) Where the tank is located so that no gravity head is produced on the dispensing device, the solenoid valve specified in sub. (10) may be omitted.

(7) SECONDARY CONTAINMENT: (a) Aboveground motor fuel tanks shall be placed within dikes which conform to section 2-2.3.3 of NFPA Standard 30 and with s. ILHR 10.345 (1).

(b) Other forms of secondary containment may be substituted for dikes if all of the design requirements of s. ILHR 10.345 (1)(c) and (d) are met and provisions are made to protect tanks and the secondary containment from vehicle collision and to protect the secondary containment from projectiles and weathering.

(8) VEHICLE COLLISION PROTECTION. (a) Aboveground motor fuel tanks shall be protected from vehicle impact by a barrier which is located at least 24 inches away from the tanks. The barrier shall be capable of withstanding a minimum horizontal live load of 1000 pounds per lineal foot acting at 18 inches above grade level.

(b) Dikes, fences and enclosures may be used to provide vehicle collision protection for aboveground motor fuel tanks if they meet the provisions of par. (a).

(9) PIPING. (a) Piping, valves and fittings shall comply with ch. 3 of NFPA 30 and this subsection.

(b) Piping shall be allowed to be aboveground within the dike or to go over the dike wall and enter the ground within 10 feet of the dike wall. All other piping shall be belowground.

(c) All aboveground piping shall be of steel and be coated to inhibit corrosion.

(d) Where aboveground piping goes over a dike wall or through an enclosure, it shall be provided with collision protection. Collision protection shall be provided on all sides of the piping not protected by the structure, buildings or dike wall. Collision protection shall be capable of resisting a horizontal impact load of 1000 lb per lineal foot at 18 inches above grade.

(e) All underground piping shall be protected against corrosion as specified in s. ILHR 10.51 (2). Corrosion protection systems shall be operated and maintained in accordance with s. ILHR 10.55.

(f) A check valve shall be installed in the piping at a point where connection and disconnection is made for tank vehicle unloading. The valve shall be protected from tampering.

(10) DISPENSING. (a) The dispensing of fuel from aboveground tanks shall comply with ch. 8 of NFPA 30A and this subsection.

(b) At commercial, industrial, government or manufacturing establishments where vehicles are fueled for use in connection with their business, at residential or commercial marine service stations, and at private registered airports, the dispensers may be located at or inside the dike wall provided users of the dispenser do not have to stand within the containment area while fueling vehicles. In all other installations, dispensers shall be located at least 30 feet from the dike wall. If a 4-hour rated fire wall constructed in accordance with s. ILHR 10.415 (4)(c) is located between the dispenser and tank, the setback may be reduced to 15 feet.

(c) An electrically operated solenoid valve shall be provided at the point of discharge at the tank. The solenoid valve shall be normally closed except when dispensing fuel.

(d) The use of gravity dispensing systems is prohibited.

(11) VENTS AND FILL OPENINGS. Vents and other openings in aboveground vehicle fueling tanks shall be provided in accordance with section 2-2 of NFPA 30 and with this subsection.

(a) Fill and vent openings shall be separate.

(b) Tanks shall be provided with bottom loading or a fill pipe that terminates within 6 inches of the bottom of the tank.

(c) All fill pipes for aboveground fueling tanks shall be locked, labeled and color coded as specified in s. ILHR 10.41.

(12) SPILL AND OVERFILL PREVENTION. (a) Spill prevention. Spill prevention shall be provided in accordance with subdv. 1. or 2. 1. Tanks shall be provided with spill containment basins or other equipment that will prevent the release of product to the environment when the transfer hose is detached from the fill pipe; or

2. The tank shall be placed in a dike and shall be filled via a nozzle with positive shut-off.

(b) Overfill prevention. 1. Prior to product delivery to an aboveground tank for vehicle fueling, the driver, operator, or attendant of the tank vehicle shall measure the available capacity of the tank to which product is to be delivered. The available capacity shall be more than the volume of product to be delivered to the tank.

2. Tanks which are filled via hand-held nozzles shall be constantly attended during product delivery and shall be provided with a vent whistle.

3. Tanks which are filled by means of a tight connection between the delivery hose and the fill pipe shall be provided with overfill protection equipment that complies with s. ILHR 10.51 (3)(a) 2.

(13) LEAK DETECTION. (a) Tanks. 1. Where diking is provided, at least 1 foot of space shall be provided between the tank and the dike walls and between the tank bottom and the dike floor to allow for visual inspection of the exterior tank surface; or

2. Where double walled tanks are used or where clearances for visual inspection of the primary containment surface are not provided as specified in subd 1., interstitial monitoring shall be provided as specified in s. ILHR 10.61 (7).

(b) Piping. Any underground piping shall comply with the leak detection requirements for pressurized piping specified in ss. ILHR 10.59 and 10.60.

ILHR 10.42 FUEL DISPENSING FOR MARINE CRAFT. (1) GENERAL. Except as otherwise provided in this section, the dispensing of Class I or II liquids into the tanks of self-propelled marine craft having a fuel capacity of less than 10,500 gallons shall comply with the requirements of NFPA Standard 30A.

Note: Dispensing of Class I or II liquids into the tanks of self-propelled marine craft having a fuel capacity of 10,500 gallons or larger is regulated by Parts 154 and 156 of Title 33 of the code of federal regulations.



(2) MARINE SERVICE STATIONS. Marine service stations shall comply with the requirements of NFPA Standard 30A except that aboveground tanks for vehicle fueling shall comply with s. ILHR 10.415 and with this subsection.

(a) Where vehicle fuel is dispersed from aboveground tanks, hoses and hose reels shall be used for dispensing and shall be located on land.

(b) Existing marine service stations shall be brought into compliance with par (a) within 10 years after the effective date of the rules.

(3) RESIDENTIAL ABOVEGROUND MARINE SERVICE STATIONS. Aboveground tanks for marine vehicle fueling for noncommercial purposes may be used at residential marine service stations in accordance with s. ILHR 10.145 and this subsection.

(a) No more than one aboveground vehicle fuel tank shall be located at a residential marine service station. The tank size shall be limited to a maximum of 560 gallons.

(b) The tanks shall be used for fueling marine vehicles used only by the residents or for maintenance of the property.

(c) The tank shall be located on land, at least 25 feet from important buildings and 10 feet from a navigable waterway, public roadway, property line or vegetation. All setbacks shall be measured from the inside of the dike wall to the important building, navigable waterway, public roadway, property line or vegetation.

(d) A means shall be provided to prevent the release of liquid due to a siphoning effect.

(e) Transfer of product shall be from tanks by means of a fixed pump listed by Underwriters Laboratories or otherwise approved by DILHR. The pump shall be designed and equipped to allow control of the flow and prevent leakage or accidental discharge. Gravity dispensing systems shall not be used.

(f) Vents shall be located so that vapors are discharged upward or horizontally away from any walls within 3 feet and that vapors are not trapped under eaves or other obstructions. Vents shall not be less than 1-1/4 inch nominal inside diameter. Fill and vent openings shall be separate.

(4) DISPENSING DIRECTLY FROM A TANK VEHICLE. Where fixed dispensing facilities are not available, dispensing of Class I or II liquids directly from a tank vehicle into permanently installed fuel tanks of self-propelled marine craft shall be permitted for emergency fueling, provided the following conditions are satisfied:

(a) The tank vehicle owner obtains an annual permit from the fire department or other authority having jurisdiction for the area where the dispensing operation is to take place.

Note: Permits for dispensing within the city of Milwaukee are available from the Department of Building Inspection and Safety Engineering.

1. The permit is on a form acceptable to the department.
2. The owner of the tank vehicle displays a current permit in the driver's compartment of the tank vehicle.
  - (b) An inspection of the premises and operations has been made and approval granted by the fire department or other authority having jurisdiction.
  - (c) The tank vehicle complies with the requirements of NFPA Standard 385.
  - (d) The dispensing nozzle is a listed manual or automatic-closing type with or without a latch-open device.
  - (e) The entire tank vehicle is in clear view of the operator during dispensing.
  - (f) A fire extinguisher having at least a 2-A:20-B:C rating is readily accessible.
  - (g) Not more than 75 feet of hose is deployed during dispensing.
  - (h) Dispensing operations are located at least 20 feet horizontally from any source of ignition, smoking or open flame.
  - (i) Minimum 3 feet high by 2 feet wide double faced signs are placed over the hose line as close as possible to the point of transfer and in a conspicuous location to the public.

1. The signs have black letters at least 2 inches high with a minimum stroke width of 1/2 inch on yellow background.

2. The signs say:

"NO SMOKING  
FUELING IN PROGRESS  
AUTHORIZED PERSONNEL ONLY"

Note: See Appendix for an illustration of a sign meeting the requirements of this section.

- (j) The tank vehicle flasher lights are in operation while dispensing.
- (k) Nighttime deliveries are made only in lighted areas.
- (l) The following precautions are observed before opening tanks and during the entire fueling process:
  1. All engines, motors, and fans are shut down;
  2. All open flames are extinguished;
  3. Smoking materials used by any person in or upon the marine craft are extinguished; and
  4. Precautions are taken to prevent fuel vapors from entering the marine craft.

(m) The fuel delivery nozzle is put in contact with the fill pipe before the flow of fuel is commenced and this contact is continuously maintained until the flow has stopped.

(n) The operator remains in attendance at the dispensing nozzle while fuel is flowing.

(o) Fuel expansion space is left in each fuel tank to prevent overflow in the event of temperature increase.

(p) The fire department having jurisdiction and the department of natural resources or an appropriate unit of emergency government are immediately notified in the event of a spill.

Note: Federal regulations 33 CFR 154 and 156 require notification of spills to federal officials. Notification can be made by calling 1-800-424-8802.

#### PART 5 - FARMS AND CONSTRUCTION PROJECTS

ILHR 10.43 APPLICATION. (1) FARMS. The provisions of ss. ILHR 10.43 to 10.49 shall apply to the storage and handling of flammable and combustible liquids having a flash point below 200°F on farms.

(2) CONSTRUCTION PROJECTS. The provisions of ss. ILHR 10.43 to 10.49 also shall apply to the storage and handling of flammable and combustible liquids of a temporary nature at road construction sites, earth moving projects, and borrow pits, or wherever it is customary to obtain fuels in bulk and dispense or transfer them under control of the owner or contractor and where long distances from other structures make it unnecessary to require compliance with the more rigid standards of this chapter.

(3) EXCEPTIONS. The provisions of this part shall not apply to the storage, handling and use of fuel oil tanks and containers connected with oil burning equipment.

ILHR 10.44 GENERAL REQUIREMENTS FOR TANK STORAGE. (1) ABOVEGROUND TANKS. Storage of flammable and combustible liquids on farms and at construction projects for private use in aboveground tanks shall be permitted as follows:

(a) In containers of 60 gallons or less capacity each in accordance with s. ILHR 10.445; or

(b) In aboveground tanks of 61 to 1,100 gallons capacity each in accordance with s. ILHR 10.45; or

(c) In aboveground tanks in excess of 1,100 gallons capacity each in accordance with s. ILHR 10.455 and chapter 2 of NFPA standard 30; or

(d) In aboveground tanks of 1,100 gallons or less capacity each in accordance with chapter 2 of NFPA standard 30.

(2) UNDERGROUND TANKS. Underground tanks at farms and construction projects shall comply with the provisions of this chapter.

(3) FILL OPENING. Fill openings on all tanks shall be provided and shall be equipped with a closure designed so that it may be locked.

(4) VENT OPENINGS. All tanks shall be vented to prevent development of pressure or vacuum, as a result of filling or emptying the tank or from atmospheric temperature changes, from exceeding the design pressure of the tank.

(5) TANK LOCATION. Aboveground tanks shall be kept outside and at least 25 feet from any building, other combustible structure, haystack or similar hazard and shall be so located, or such additional distance from buildings shall be maintained to insure that any vehicle, equipment or vessel being filled directly from the tank will be at least 25 feet from any building.

(6) TYPES OF ABOVEGROUND TANKS. Tanks shall be of one of the following types:

(a) Tanks with top openings only. Tanks designed with all openings in the top of the tank shall be mounted and equipped as follows:

1. Stationary tanks shall be mounted on noncombustible supports approximately 6 inches in height in a stable position;

2. Portable tanks equipped with attached metal legs resting on shoes or runners shall conform with the following:

a. The shoes or runners shall be spaced at least one tank diameter apart so the tank is supported in a stable position;

b. The shoes or runners shall be designed to rest upon the ground so that the entire tank and its supports may be moved as a unit; and

3. a. Tanks shall be equipped with a tightly and permanently attached approved pumping device having an approved hose of sufficient length for filling vehicles, equipment or vessels to be served from the tank.

b. Either the pump or the hose shall be padlocked to its hanger when not in use.

c. An effective anti-siphoning device shall be included in the pump discharge.

d. Siphons or internal pressure discharge devices may not be used.

(b) Tanks elevated for gravity discharge. Tanks may be provided with an opening in the bottom or the end of the tank for gravity dispensing of flammable liquids. Gravity type tanks shall be mounted and equipped as follows:

1. Supports to elevate the tank for gravity discharges shall be of noncombustible materials and shall be of proper design and strength to provide stability;

2. Bottom openings for gravity discharge shall be equipped with an internal valve that will close automatically in the event of fire through the operation of an effective heat actuated releasing device, and shall be supplemented by a second valve that can be operated manually; and

3. The gravity discharge outlet shall be provided with a listed hose equipped with a self-closing valve at the discharge end, of a type that can be padlocked to its hanger to prevent tampering.

ILHR 10.445 INDIVIDUAL CONTAINERS OF 60 GALLONS OR LESS CAPACITY EACH.

(1) CONTAINER CONSTRUCTION. Individual containers each having a capacity of 60 gallons or less shall be closed metal drums.

(2) INTERCONNECTION PROHIBITED. Individual containers shall not be interconnected.

(3) PUMPING DEVICES. Pumping devices or faucets used for dispensing flammable and combustible liquids shall have spring loaded self-closing mechanisms maintained to prevent leakage.

(4) PRESSURE DISCHARGE DEVICES. Discharge devices requiring pressure on the container are prohibited.

(5) STORAGE AND LOCATION. Containers shall be stored as follows:

(a) Outside and at least 25 feet from any building, other combustible structures, haystack, combustible waste material or similar hazard; or

(b) Inside a building located at least 25 feet from any other building and used exclusively for the storage of flammable and combustible liquids.

(6) BUILDINGS USED FOR STORAGE. Buildings used for storage of flammable and combustible liquids shall be provided with cross-ventilation with at least 2 vents of 64 square inches in area each, placed at floor level.

ILHR 10.45 ABOVEGROUND TANKS OF 61 to 1100 GALLONS CAPACITY EACH. Tanks

shall be constructed in accordance with this section or UL Standard 142. (1) TANK MATERIAL. Tank material for aboveground tanks shall conform to the requirements of Table 10.45.

Table 10.45

| Capacity in Gallons | Minimum Thickness of Steel<br>(Mfrs. Std. Gauge No.) |
|---------------------|--|
| 61-560 . . . . .    | 14   |
| 561-1100 . . . . .  | 12   |

(2) TANK CONSTRUCTION. Aboveground tanks shall be of single compartment design constructed in accordance with accepted engineering practice.

(3) TANK JOINTS. Tank joints shall be welded.

(4) TANK HEADS. Aboveground tank heads over 6 feet in diameter shall be dished, stayed, braced or reinforced.

ILHR 10.455 ABOVEGROUND TANKS ON FARMS EXCEEDING 1100 GALLONS INDIVIDUAL CAPACITY. Aboveground tanks exceeding 1100 gallons individual capacity located on farms shall comply with the provisions of s. 2-2 of NFPA Standard 30 and with the applicable provisions of this subchapter for aboveground tank installation, except a minimum distance of 25 feet shall be maintained from buildings, other combustible structures, hay stacks and similar hazards.

ILHR 10.46 MARKING OF TANKS AND CONTAINERS. (1) Containers for the storage of flammable liquids shall be conspicuously marked with the name of the product contained.

(2) Tanks of 1100 gallons individual capacity or less shall bear the words "FLAMMABLE--KEEP FIRE AWAY" and the additional marking "KEEP 25 FEET FROM BUILDINGS". All required lettering shall be at least one inch in height.

(3) Tanks and containers of 275 gallons or less capacity for the storage of flammable liquids with flash points less than 100°F shall be painted a bright red.

#### PART 6 - OIL BURNING

ILHR 10.47 USE OF APPROVED EQUIPMENT. (1) PUBLIC BUILDINGS AND PLACES OF EMPLOYMENT. Oil burning equipment installed to serve public buildings or places of employment shall conform with the applicable requirements of ch. ILHR 64.

(2) ALL OTHER LOCATIONS. Oil burning equipment installed in all other locations shall be listed by Underwriters Laboratories.

ILHR 10.471 OIL STORAGE AND SUPPLY SYSTEMS. (1) UNDERGROUND. Underground storage tank systems serving oil burning equipment shall comply with subch. VII.

(2) ABOVEGROUND. Aboveground storage tank systems serving oil burning equipment shall comply with this part.

ILHR 10.472 DESIGN AND CONSTRUCTION OF ABOVEGROUND TANKS. (1) Tanks may be of any shape or type consistent with sound engineering design.

(2) Metal tanks shall be welded, riveted, and caulked, brazed, or bolted, or constructed by use of a combination of these methods. Filler metal used in brazing shall be nonferrous metal or an alloy having a melting point above 1,000°F and below that of the metal joined.

(3) Tanks shall be used under substantially atmospheric pressure and shall be built in accordance with approved standards of design. Atmospheric tanks may be built in accordance with:

(a) Underwriters Laboratories, Inc. Standard for Steel Aboveground Tanks for Flammable and Combustible Liquids, UL 142; Standard for Steel Underground Tanks for Flammable and Combustible Liquids, UL 58; or Standard for Steel Inside Tanks for Oil-burner Fuel, UL 80.

(b) American Petroleum Institute Standard No. 650, Welded Steel Tanks for Oil Storage, Seventh Edition.

(4) Tanks built according to Underwriters Laboratories, Inc. requirements in par. (3) (a) may be used for operating pressures not exceeding 1 psig and shall be limited to 2.5 psig under emergency venting conditions.

(5) The tank shall be designed for the maximum static head which will be imposed when the vent or fill pipe is filled with oil. The maximum static head so imposed on tanks built in accordance with par. (3) (a) shall not exceed 10 psig at the bottom of the tank.

(6) Pressure tanks shall be built in accordance with applicable requirements of the ch. ILHR 41-42, Wis. Adm. Code.

ILHR 10.473 INSTALLATION OF UNENCLOSED TANK INSIDE BUILDINGS. (1) ALLOWABLE UNENCLOSED TANKS. A supply tank inside of a building that is not enclosed by fire-resistive construction as described in s. ILHR 10.474 shall conform to one of the following:

(a) A supply tank not larger than 10 gallons shall be specifically approved for the purpose; or

(b) An approved safety can may be used as a storage tank; or

(c) A supply tank larger than 10 gallons but not larger than 660 gallons that meets the construction provisions of Standard UL 80 or as provided in s. ILHR 10.472 (6).

(2) SIZE AND LOCATION. A supply tank shall be of such size and shape that it can be installed in and removed from the building as a unit. The size and location of unenclosed tanks inside of any building or any one portion of a building separated from other portions by a fire wall shall be in accordance with the following:

(a) Not more than 6 safety cans may be located in any one or more stories of a building. No such safety can shall have an individual capacity exceeding 5 gallons.

(b) A supply or storage tank located above the lowest story, cellar, or basement shall not exceed 60-gallons capacity and the total capacity of tanks so located shall not exceed 60 gallons.

(c) A supply tank shall be not larger than 660 gallons. Not more than one 660-gallon tank or two tanks of aggregate capacity of 660 gallons or less shall be connected to any single oil-burning appliance. The aggregate capacity of such tanks installed in the lowest story, cellar, or basement of a building and unenclosed shall not exceed 1,320 gallons unless separation is provided for each 660 gallons of tank capacity. The separation shall consist

of an unpierced masonry wall or partition extending from the lowest floor to the ceiling above the tank or tanks and shall have a fire-resistance rating of not less than 2 hours. See Figure 10.473-1.

Note: See also ss. ILHR 54.14, 55.29, 56.15, 57.14, 58.24, 59.21 and 62.32 Wisconsin Administrative Building and Heating, Ventilating and Air Conditioning Code for more requirements for the isolation of fuel tanks.

(4) CLEARANCES. (a) An unenclosed supply tank less than 10 gallons shall be placed at least 2 feet horizontally from any source of heat either in or external to the appliance being served but in any case shall be located so that the temperature of the oil in the tank will not exceed 25°F above room temperature.

(b) An unenclosed supply tank of 10 gallons capacity or larger shall be placed at least 5 feet from any fire or flame either in or external to any fuel-burning appliance. The tank shall not obstruct quick and safe access to any utility service meters, switch panels and shutoff valves.



Figure 10.473-1

Installation of Unenclosed Tanks

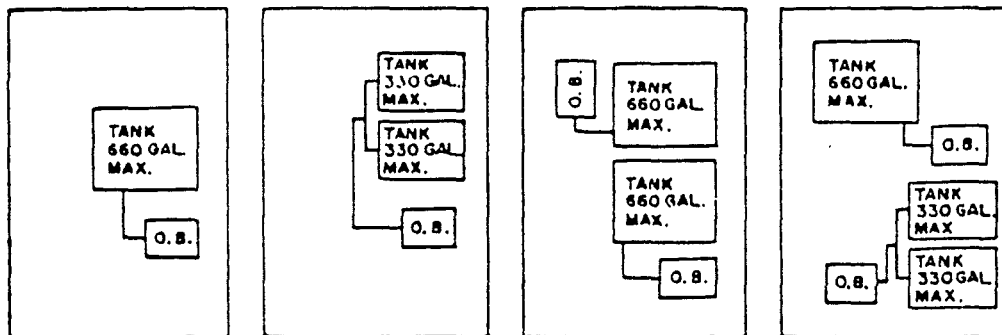

ACCEPTABLE

ACCEPTABLE

ACCEPTABLE

ACCEPTABLE

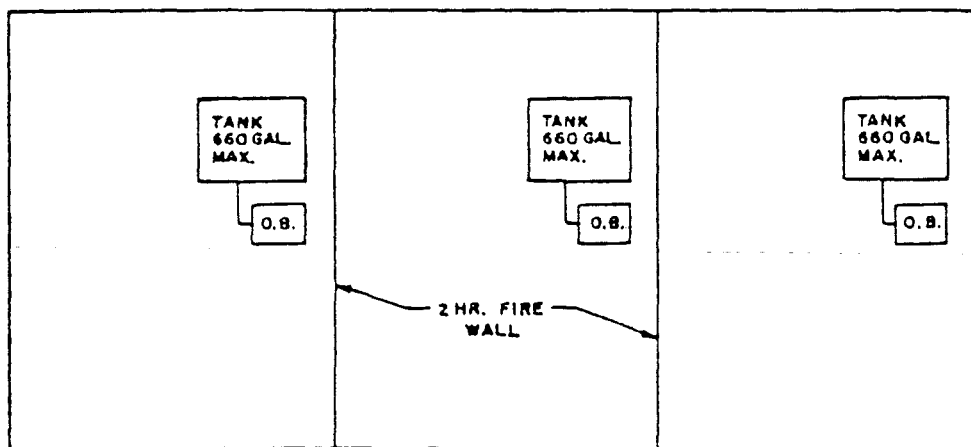

ACCEPTABLE

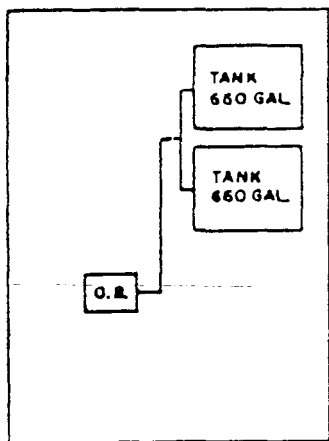

NOT ACCEPTABLE

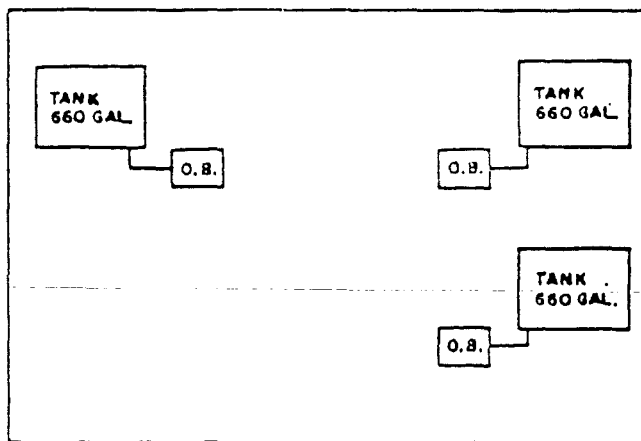

NOT ACCEPTABLE

**O.B. means one or more oil burners**

(5) SUPPORTS. An unenclosed supply tank shall be securely supported by rigid noncombustible supports to prevent settling, sliding or lifting.

(6) PITCH. When a supply tank larger than 10 gallons capacity is provided with an opening in the bottom for use as a burner supply connection or as a drain, the tank shall be pitched toward the opening with a slope of not less than 1/4 inch per foot of length.

(7) SHUTOFF VALVE. A shutoff valve shall be provided immediately adjacent to the burner supply connection at the bottom of a supply tank.

(8) VENT PIPE. A supply tank larger than 10 gallons capacity shall be provided with an open-vent pipe not smaller than the pipe size specified in Table 10.473 and a fill pipe, both terminating outside the building.

Table 10.473  
MINIMUM VENT PIPE REQUIREMENTS

| Capacity of Tank,<br>Gallons | Inside<br>Diameter of Vent,<br>Iron Pipe Size |
|------------------------------|---|
| 500 or less                  | 1 1/4 inches                                  |
| 501 to 3,000                 | 1 1/2 inches                                  |
| 3,001 to 10,000              | 2 inches                                      |
| 10,001 to 20,000             | 2 1/2 inches                                  |
| 20,001 to 35,000             | 3 inches                                      |

(9) GAUGING DEVICE. A supply tank provided with fill and vent pipes shall be equipped with a gauging device.

(10) OTHER OPENINGS. Any unused opening in a tank equipped with fill and vent pipes shall be closed vaportight by a pipe plug or tightly screwed cap.

(11) CROSS CONNECTION. Cross connection of 2 supply tanks to the same burner shall be acceptable. Two cross connected supply tanks may be provided with a single vent pipe, as shown in Figures 10.473-2 and -3. The vent pipe shall be provided with a vent whistle.

ILHR 10.474 INSTALLATION OF ENCLOSED SUPPLY TANKS INSIDE BUILDINGS.

(1) SIZES REQUIRING ENCLOSURE. (a) A supply tank larger than 660 gallons capacity shall be enclosed by fire-resistive construction when installed inside of a building.

(b) Tankage inside of a building in excess of that permitted to be unenclosed under ILHR 10.473 (2) (c) shall be enclosed with fire-resistive construction.

(2) TANKS ON UPPER FLOORS. Regardless of enclosure, a supply or storage tank located above the lowest story, cellar, or basement shall not exceed 60 gallon capacity and the total capacity of tanks so located shall not exceed 60 gallons.

(3) TANK CONSTRUCTION REQUIREMENTS. Only a tank meeting the construction provisions of Standards UL 80 and UL 142, or as provided in s. ILHR 10.472 (6) shall be installed enclosed inside of a building.

(4) CAPACITY LIMITATIONS. Enclosed tanks in buildings shall be in accordance with the following:

(a) In buildings of other than fire-resistive types 1 or 2 construction, the gross capacity of the tank or tanks shall be not more than 10,000 gallons.

(b) In buildings of fire-resistive types 1 or 2 construction, the gross capacity of the tank or tanks shall be not more than 15,000 gallons.

Figure 10.473-2  
Recommended Arrangement of Two Fuel Oil Tanks of Not More than 660 Gallons Aggregate Capacity.\*

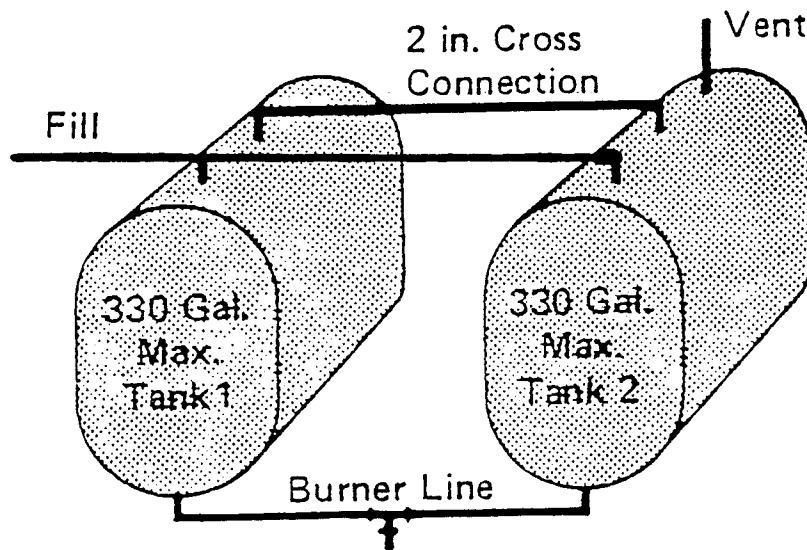

\*NOTE: In this arrangement of 2 tanks two fill pipes and one vent pipe are used. During filling oil enters Tank No. 1. The displaced vapors pass through the cross connection at the top into Tank No. 2. The expansion zone for both tanks is obviously in Tank No. 2 until the tanks equalize after filling is completed.

Figure 10.473-3  
Detail of the cross connection which can be used in Figure 10.473-2.

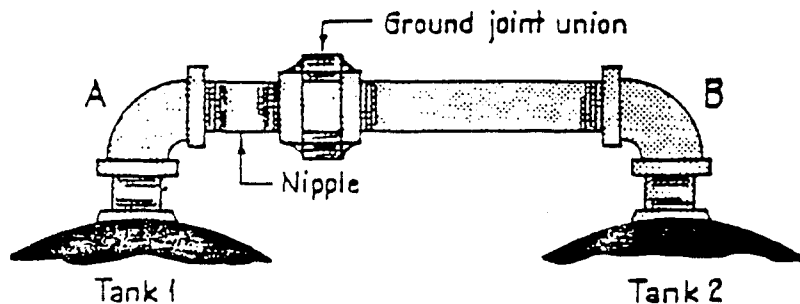

(5) ENCLOSURE REQUIREMENTS. (a) The enclosure for tanks in sub. (1) shall include walls, a floor and a top and be formed from walls, partitions, floors, or floor-ceiling assemblies having a fire resistance rating of not less than 3 hours with the walls bonded to the floor. If the walls of such enclosure extend to and are bonded to the underside of a concrete floor or roof that has a fire resistance rating of not less than 3 hours, a separate top is not required for the tank enclosure.

(b) Each tank enclosure shall be provided with an opening protected by a self-closing listed 3-hour A-label fire door assembly and a noncombustible liquid-tight sill or ramp at least 6 inches high. Fire doors shall be installed in accordance with NFPA 80, Standard for Fire Doors and Windows. If the sill or ramp is more than 6 inches high, the walls to a height corresponding to the level of oil that will be retained shall be built to withstand the lateral pressure due to the liquid head.

(6) TANK FOUNDATIONS. The tank shall be supported at least 4 inches above the floor by masonry saddles at least 12 inches thick, spaced not more than 8 feet on centers and extending the full width of the tank. At least a 15-inch clearance shall be provided between the tank and the top and walls of the tank enclosure for the purpose of inspection and repair.

(7) TANK CONNECTIONS. All connections to an enclosed supply tank having a capacity of more than 660 gallons shall be made through the top of the tank, and the transfer of oil shall be by pump only and through continuous piping to and from the consuming appliances.

(8) VENTILATION. Provision shall be made for adequate ventilation of such enclosures prior to entering for inspection or repair of tanks.

(9) TANK VENTS. An enclosed supply tank shall be equipped with an open vent or an automatically operated vent, terminating outside the building. Vent openings and vent pipes shall be of ample size to prevent abnormal pressure in the tank during filling but not smaller than the pipe size specified in Table 10.473.

(10) GAUGING. An enclosed supply tank shall be provided with a gauging device.

ILHR 10.475 INSTALLATION OF OUTSIDE ABOVEGROUND TANKS NOT LARGER THAN 660 GALLONS. (1) CAPACITY LIMIT. Not more than one 660-gallon tank or two tanks of aggregate capacity of 660 gallons or less shall be connected to oil-burning appliances in accordance with this section. Tanks exceeding this limit shall comply with s. ILHR 10.476.

*per DILHR  
1/25/91*  
(2) MULTIPLE TANKS. Two supply tanks connected to the same burner as permitted by sub. (1) above may be cross-connected and provided with a single fill and a single vent as shown in Figures 10.473-2 and -3 but when so connected, they shall be on a common slab and rigidly secured, one to the other. A space shall be maintained between the tanks to prevent the rubbing of sidewalls and accumulation of debris and to allow for air circulation to reduce condensation and rust.

(3) SUPPORTS. Tanks having a capacity of 660 gallons or less shall be securely supported by rigid noncombustible supports to prevent settling, sliding, or lifting.

(4) PORTABLE CONTAINER FILLING. The filling of a portable container from a storage tank larger than 60 gallons shall be by means of a hand pump only.

(5) SHUTOFF VALVE. A shutoff valve shall be provided in the burner supply line immediately adjacent to the gravity feed connection of a supply tank.

(6) VENTS. A tank not larger than 660 gallon capacity shall be equipped with an open vent not smaller than the pipe size specified in Table 10.473.

(7) GAUGING DEVICES. A tank shall be provided with a means to determine the liquid level.

(8) FILL PIPES. The fill opening shall be sized and located to permit ready filling in a manner that will avoid spillage.

ILHR 10.476 INSTALLATION OF OUTSIDE ABOVEGROUND TANKS LARGER THAN 660 GALLONS. (1) DESIGN AND CONSTRUCTION. A tank having a capacity of more than 660 gallons shall meet the construction standard specified in s. ILHR 10.472 (6).

(2) GAUGING DEVICES. A tank shall be provided with a means to determine the liquid level.

ILHR 10.477 LOCATION OF OUTSIDE ABOVEGROUND TANKS. Outside aboveground heating oil tanks shall be located with respect to property lines, public ways and important buildings on the same property in accordance with section 2-2.1 of NFPA Standard 30. The shell-to-shell spacing between adjacent aboveground heating oil tanks shall comply with section 2-2.2 of NFPA Standard 30.

ILHR 10.478 CONTROL OF RELEASES FROM ABOVEGROUND TANKS EXCEEDING 660 GALLONS CAPACITY. Outside aboveground heating oil tanks exceeding 660 gallons capacity shall be provided with a containment system that complies with section 2-2.3 of NFPA Standard 30 and s. ILHR 10.345.

ILHR 10.479 VENTING FOR ABOVEGROUND TANKS. Outside aboveground heating oil tanks shall be provided with normal venting in accordance with section 2-2.4 of NFPA Standard 30. Emergency relief venting for outside aboveground heating oil tanks shall be provided in accordance with section 2-2.5 of NFPA Standard 30.

ILHR 10.48 SUPPORTS, FOUNDATIONS, AND ANCHORAGE. Supports, foundations and anchorage for aboveground heating oil tanks in all locations shall comply with section 2-5 of NFPA Standard 30.

ILHR 10.481 TESTING. All aboveground heating oil tanks shall be tested before they are placed in service in accordance with section 2-7 of NFPA Standard 30.

ILHR 10.482 PIPING MATERIALS AND DESIGN FOR ABOVEGROUND TANKS. (1) All piping shall be wrought-iron, steel or brass pipe, or brass or copper tubing. Wall thicknesses of wrought iron and steel pipe shall be in accordance with design methods outlined in the Standard on Wrought-Steel and Wrought-Iron Pipe, ANSI B36.10M. Listed flexible metal hose may be used to reduce the effect of jarring and vibration or where rigid connections are impracticable, and shall be installed in full compliance with its listing.

(2) Piping used in the installation of oil burners and appliances other than conversion range oil burners shall be not smaller than 3/8-inch iron pipe size or 3/8-inch outside diameter tubing except that 1/4-inch pipe or 5/16-inch outside diameter tubing may be used in the suction line of systems where the top of the tank is below the level of the oil pump. Copper tubing shall have 0.035-inch nominal and 0.032-inch minimum wall thicknesses.

(3) Pipe shall be connected with standard fittings and tubing with fittings of listed type. Pipe connectors made of combustible materials or depending upon the frictional characteristics of combustible materials shall not be used inside of buildings or aboveground outside of buildings. If used belowground outside of buildings, connectors shall be of listed type and installed in accordance with their listing. All threaded joints and connections shall be made tight with suitable lubricant or pipe compound. Unions requiring gaskets or packings, right or left couplings, and sweat fittings employing solder having a melting point of less than 1,000°F shall not be used in oil lines. Cast-iron fittings shall not be used.

(4) Piping shall be substantially supported and protected against physical damage and, where necessary, protected against corrosion. All buried piping shall be protected against corrosion in accordance with s. ILHR 10.51 (2).

(5) Proper allowance shall be made for expansion, contraction, jarring, and vibration.

ILHR 10.483 FILL AND RETURN PIPING. (1) FILL PIPES (a) A fill pipe shall terminate outside of a building at a point at least 2 feet from any building opening at the same or lower level. A fill pipe shall terminate in a manner designed to minimize spilling when the filling hose is disconnected. The fill opening shall be equipped with a tight metal cover designed to discourage tampering.

(b) A fill pipe shall be sized and located to permit ready filling in a manner that will avoid spillage, and it shall be identified at its terminus as a fuel oil fill.

(2) RETURN LINES. A return line from a burner or pump to a supply tank shall enter the top of the tank.

(3) CROSS CONNECTIONS. Cross connections, except between 2 supply tanks not exceeding 660 gallons aggregate capacity, permitting gravity flow from one tank to another shall be prohibited.

(4) AUXILIARY TANKS. (a) An auxiliary tank shall be filled by a pump transferring the oil through continuous piping from the supply tank.

(b) An auxiliary tank shall be located at a level above the top of the supply tank from which it is filled.

(c) An auxiliary tank shall be provided with an overflow pipe draining to the supply tank and extending into the top of the supply tank not more than one inch. This requirement does not apply to an auxiliary tank specifically listed for use without an overflow pipe.

(d) An overflow pipe from an auxiliary tank and a return line from a burner or pump shall have no valves or obstructions.

(5) INSIDE HEATING OIL TANKS TAKEN OUT OF SERVICE. At the time an inside heating oil tank is removed or taken out of service, the fill and vent pipe shall be removed from the exterior of the building.

ILHR 10.484 SUPPLY CONNECTIONS. (1) LOCATION. (a) All piping, except the burner supply line from a tank having a capacity not over 660 gallons and the cross connection between 2 tanks having an aggregate capacity of 660 gallons or less, shall be connected into the top of a supply tank. When 2 tanks are cross connected, the tops of the tanks shall be on the same horizontal plane.

(b) The burner supply connection to a tank having a capacity of more than 660 gallons or to 2 or more tanks having an aggregate capacity of more than 660 gallons shall be connected into the top of each tank, except as permitted by sub. (5) or s. ILHR 10.489 (6).

(2) TRANSFER PUMP USE. A transfer pump or an automatic pump may be used to deliver oil from a supply tank to a burner or to an auxiliary tank. Except as permitted by sub. (5) or s. ILHR 10.488, a transfer pump shall not be connected to a tank having a capacity over 660 gallons or to 2 tanks having an aggregate capacity of over 660 gallons.

(3) INLET PRESSURE. The pressure at the oil supply inlet to an appliance shall be not greater than 3 psi unless the appliance is listed or labeled for a higher inlet pressure.

(4) PIPING PITCH. Where supply tanks are set below the level of the burner, the oil piping shall be so laid as to pitch toward the supply tank without traps.

(5) COMMERCIAL AND INDUSTRIAL INSTALLATIONS. (a) For commercial and industrial installations the oil supply from tanks of any capacity permitted by this standard may be in accordance with the following:

(b) The burner supply line may be connected to an outside aboveground supply tank at a point below the liquid level, but each such connection shall be provided with an internal or external shutoff valve located as close as practicable to the shell of the tank. External valves and their connections to the tank shall be of steel.

(c) A transfer pump may be used.

ILHR 10.485 VENT PIPING. (1) INSTALLATION. Vent pipes shall be so laid as to drain toward a tank without sags or traps in which liquid can collect. They shall be located so that they will not be subjected to physical damage aboveground. Vent pipes from tanks may be connected into one outlet pipe. The outlet pipe shall be at least one pipe size larger than the largest connected individual vent pipe. In no case shall the point of connection between 2 or more vent pipes be lower than the top of any fill pipe opening. The lower end of a vent pipe shall enter the tank through the top and shall extend into the tank not more than one inch.

(2) TERMINATION. Vent pipes shall terminate outside of buildings at a point not less than 2 feet measured vertically or horizontally from any building opening. Outer ends of vent pipes shall terminate in a weatherproof vent cap or fitting or be provided with a weatherproof hood. All vent caps shall have a minimum free open area equal to the cross-sectional area of the vent pipe and shall not employ screens finer than 4 mesh. Vent pipes shall terminate sufficiently above the ground to avoid being obstructed with snow and ice. Vent pipes from tanks containing heaters shall be extended to a location where oil vapors discharging from the vent will be readily diffused. If the static head with a vent pipe filled with oil exceeds 10 psi, the tank shall be designed to withstand the maximum static head which will be imposed.

(3) CROSS CONNECTION. Vent pipes may not be cross-connected with pipes other than vent pipes.

ILHR 10.486 PRESSURIZED TANK FEED. Air or other gases may not be used to pressurize tanks.

ILHR 10.487 OIL GAUGING. (1) APPLICATION. All tanks in which a constant oil level is not maintained by an automatic pump shall be equipped with a method of determining the oil level.

(2) LEAK PREVENTION. (a) Gauging devices such as liquid level indicators or signals shall be designed and installed so that oil or vapor will not be discharged into a building from the fuel supply system. Inside tanks provided with fill and vent pipes used for No. 1 or No. 2 fuel oil shall be provided with a device to indicate either visually or audibly at the fill point when the oil in the tank has reached a predetermined safe level.

(b) Tanks used in connection with any oil burner shall not be equipped with any gauge which, when broken, will permit the escape of oil from the tank.



ILHR 10.488 CENTRALIZED OIL DISTRIBUTION SYSTEMS. (1) APPLICATION. A centralized oil distribution system shall conform to this section and all other applicable provisions of this part.

(2) SUPPLY PIPING. Oil may be fed from the supply tank or tanks by gravity or by transfer pump. All distribution piping outside of diked areas shall be underground. Underground piping shall be protected from corrosion in accordance with s. ILHR 10.51 (2). Pressurized underground piping shall also comply with the release detection requirements of s. ILHR 10.60 (2)(a).

(3) TANK CAPACITY. The capacity of a single tank or the aggregate capacity of two or more tanks supplying a centralized oil distribution system shall be not more than 20,000 gallons except that underground tanks installed in accordance with subch. VII may be of any capacity permitted by this standard.

(4) CONNECTIONS. A distribution main may be connected to a tank or tanks having aggregate capacity of not more than 20,000 gallons at a point below the liquid level. When the distribution main is so connected, a readily accessible internal or external shutoff valve shall be installed in the main as close as practical to the tank. If external and aboveground, the shutoff valve and its tank connections shall be made of steel. Connections between the tank and the distribution main shall be made with double swing joints, flexible connectors, or otherwise arranged to permit the tank to settle without damaging the system. Such connections when aboveground shall be located within the diked area.

(5) SAFETY CONTROLS. Only appliances equipped with primary safety controls specifically listed for the appliance shall be connected to a centralized oil distribution system.

(6) SHUTOFF VALVES. (a) A readily accessible manual shutoff valve shall be installed in each branch line that enters a building, mobile home, travel trailer, or other structure. This valve may be either inside or outside of such structure. If outside, the valve shall be protected from weather and damage. If inside, the valve shall be located directly adjacent to the point at which the supply line enters the structure.

(b) A device shall be provided that will automatically shut off the oil supply at or ahead of the point where it enters the interior of the structure, if the supply line between this device and the appliance is broken. This device shall be located on the appliance side of the manual shutoff valve required in s. ILHR 10.488 (8) (a). This device shall be solidly supported and protected from damage.

(7) OIL PRESSURE LIMIT. Means shall be provided to limit the oil pressure at the appliance inlet to a maximum of 3 psig. If a pressure reducing valve is to be used, it shall be a type approved for the service.

(8) RESET DEVICE. A manual-reset device shall be provided to shut off automatically the oil supply to the appliance if the oil pressure at the appliance inlet exceeds 8 psig, except that such a shutoff device is not required when either the distribution system is supplied from a gravity tank in which the maximum level of oil (hydrostatic head) is such that the pressure

in the system at the appliance inlet cannot exceed 3 psig, or when, the pressure limiting device provided in accordance with sub. (7) is such that if the device fails to regulate the pressure to not more than 3 psig, the oil supply will be automatically shut off.

ILHR 10.489 OIL DISTRIBUTION SYSTEMS FOR ROOF-MOUNTED OR CEILING-SUSPENDED OIL-FIRED UNITS. (1) APPLICATION. An oil distribution system for roof-mounted or ceiling-suspended oil-fired units shall conform to this section and all other applicable provisions of this standard.

(2) OIL FEED. (a) Oil may be fed directly to the burner, directly from a tank or by means of a fuel distribution system that includes a transfer pump.

(b) When fed directly from a storage tank, the fuel supply system shall be designed so that under normal operating conditions the burner fuel unit operates with less than 10 inches vacuum at the inlet.

(c) If the limitations of par. (b) are exceeded, a fuel supply system incorporating a transfer pump is needed and shall be provided.

(3) FUEL SUPPLY SYSTEMS. The fuel supply systems shall conform to the following general requirements:

(a) All components, including pumps, reservoirs, valves, regulators, relief valves and controls, shall be listed for use with fuel oil.

(b) Control and relief provisions shall be provided to preclude pressurizing the main distribution lines 50 percent above the working pressure.

(c) No dead-ended main distribution oil lines shall be permitted unless provisions are made for air purging. These purge points shall be closed by plugs or caps when not actually in use.

(d) Means shall be provided to limit the oil pressure at the burner inlet to a maximum of 3 psig. If a pressure reducing valve is to be used, it shall be a type approved for the service.

(4) CAPACITY. The capacity of a single tank or the aggregate capacity of two or more tanks supplying a distribution system for roof-mounted or ceiling-suspended oil-fired units shall not be more than 20,000 gallons except that underground tanks installed in accordance with subch. VII may be of any capacity.

(5) AUXILIARY TANKS. If required by design, individual supply tanks such as auxiliary or day tanks connected to burners shall comply with provisions of ss. ILHR 10.473 (2) (b), and 10.483 (4).

(6) VALVES AND DRIP TRAYS. Valves and drip trays shall be provided on roof-mounted units to prevent oil spillage during service.

(7) SHUTOFF VALVES. A readily accessible and identified manual shutoff valve shall be installed in each branch line that serves an individual burner and in the oil distribution line. This valve may be either inside or outside of a protective enclosure. If outside, the valve shall be protected from

weather and damage. If inside, the valve shall be located directly adjacent to the point at which the supply line enters the protective enclosure.

(8) LISTED EQUIPMENT. Only appliances equipped with primary safety controls specifically listed for the appliance shall be connected to a distribution system for roof-mounted or ceiling-suspended oil-fired units.

(9) SWITCHING. A switch in the electrical supply to the transfer pump shall be provided. Such a switch, which is capable of being locked in the open position, shall be at a convenient location so the fuel supply system can be shut down for maintenance. Provisions shall be made so that shutdown of the fuel supply system shall interrupt the electrical supply to the units described in sub. (1).

ILHR 10.49 TESTS OF PIPING. (1) TEST CONDITIONS AND PROCEDURES. After installation and before being covered, piping shall be tested for leaks. Piping shall be tested hydrostatically, or with equivalent air pressure, at not less than 1 1/2 times the maximum working pressure but not less than 5 psi at the highest point of the system. The test shall be made so as not to impose a pressure of more than 10 psi on the tank. This test shall be maintained for at least 30 minutes or for sufficient time to complete visual inspection of all joints and connections. Instead of a pressure test, suction lines may be tested under a vacuum of not less than 20 in. maintained for at least 30 minutes.

(2) TESTS EXCEEDING 10 PSI. When the vertical length of the fill and vent pipes is such that when filled with liquid the static head imposed exceeds 10 psi, the piping shall be tested hydrostatically to a pressure equal to the static head thus imposed.

SUBCHAPTER VI - GENERAL REQUIREMENTS  
FOR  
GROUNDWATER PROTECTION

(All Underground Storage Tanks Except Farm  
and Residential Tanks of 1100 Gallons or Less  
Capacity Used for Storing Motor Fuel for  
Noncommercial Purposes and Underground  
Storage Tanks Used for Storing Heating  
Oil for Consumptive Use on the  
Premises Where Stored)

PART 1 - PROGRAM SCOPE AND INTERIM PROHIBITION

ILHR 10.50 APPLICABILITY. (1) The requirements of this subchapter apply to all owners and operators of an UST system as defined in s. ILHR 10.01 except as otherwise provided in subs. (2) to (3). Any UST system listed in sub. (3) shall meet the requirements of s. ILHR 10.505.

(2) The following UST systems are excluded from the requirements of this subchapter:

(a) Any UST system holding hazardous wastes listed or identified under Subtitle C of the Solid Waste Disposal Act, or a mixture of such hazardous waste and other regulated substances.

(b) Any wastewater treatment tank system that is part of a wastewater treatment facility regulated under Section 402 or 307(b) of the Clean Water Act.

(c) Equipment or machinery that contains regulated substances for operational purposes such as hydraulic lift tanks and electrical equipment tanks.

(d) Any emergency spill or overflow containment UST system that is expeditiously emptied after use.

(e) Any farm or residential UST system of 1,100 gallons or less capacity used for storing motor fuel for noncommercial purposes.

(f) Any UST system used for storing heating oil for consumptive use on the premises where stored.

(3) Parts 2, 3, 4, 5 and 7 do not apply to any of the following types of UST systems:

(a) Wastewater treatment tank systems;

(b) Any UST systems containing radioactive material that are regulated under the Atomic Energy Act of 1954 (42 USC 2011 and following);

(c) Any UST system that is part of an emergency generator system at nuclear power generation facilities regulated by the Nuclear Regulatory Commission under 10 CFR 50 Appendix A;

(d) All portions of airport hydrant fuel distribution systems except for the underground storage tanks included in those systems; and

(e) UST systems with field-constructed tanks.

ILHR 10.505 INTERIM PROHIBITION FOR DEFERRED UST SYSTEMS. (1) No person may install an UST system listed in s. ILHR 10.50 (3) for the purpose of storing regulated substances unless the UST system, whether of single- or double-wall construction:

(a) Will prevent releases due to corrosion or structural failure for the operational life of the UST system;

(b) Is cathodically protected against corrosion, constructed of noncorrodible material, steel clad with a noncorrodible material, or designed in a manner to prevent the release or threatened release of any stored substance; and

(c) Is constructed or lined with material that is compatible with the stored substance.

(2) Notwithstanding sub. (1), an UST system without corrosion protection may be installed at a site that is determined by a corrosion expert not to be corrosive enough to cause it to have a release due to corrosion during its operating life. Owners and operators shall maintain records that demonstrate compliance with the requirements of this subsection for the remaining life of the tank.

Note: The National Association of Corrosion Engineers Standard RP-02-85, "Control of External Corrosion on Metallic Buried, Partially Buried, or Submerged Liquid Storage Systems," may be used as guidance for complying with sub. (2).

## PART 2 - UST SYSTEMS: DESIGN, CONSTRUCTION, INSTALLATION AND NOTIFICATION

ILHR 10.51 PERFORMANCE STANDARDS FOR UST SYSTEMS INSTALLED AFTER DECEMBER 22, 1988. In order to prevent releases due to structural failure, corrosion, or spills and overfills for as long as the UST system is used to store regulated substances, all owners and operators of UST systems installed after December 22, 1988, shall meet the requirements of this part. The operational life of any component of a UST system assumed for design purposes shall not be less than the warranty period for that component.

(1) TANKS. Each tank shall be properly designed and constructed, and any portion in contact with the ground that routinely contains product shall be protected from corrosion, in accordance with a code of practice developed by a nationally recognized association or independent testing laboratory as specified below:

(a) The tank is constructed of fiberglass-reinforced plastic meeting one of the following standards:

1. Underwriters Laboratories Standard 1316, "Standard for Glass Fiber-Reinforced Plastic Underground Storage Tanks for Petroleum Products";

2. Underwriters Laboratories of Canada CAN 4-S615-M83 "Standard for Reinforced Plastic Underground Tanks for Petroleum Products"; or

3. American Society of Testing and Materials Standard D4021;

(b) The tank is constructed of steel and cathodically protected in the following manner:

1. The tank is coated with a suitable dielectric material;

2. Field-installed cathodic protection systems are designed by a corrosion expert;

3. Impressed current systems are designed to allow determination of current operating status as required in s. ILHR 10.55 (3); and

4. Cathodic protection systems are operated and maintained in accordance with s. ILHR 10.55 and the tank complies with one of the following standards:

a. Steel Tank Institute "Specification for STI-P3<sup>®</sup> System of External Corrosion Protection of Underground Steel Storage Tanks";

b. Underwriters Laboratories Standard 1746, "Corrosion Protection Systems for Underground Storage Tanks";

c. Underwriters Laboratories of Canada CAN4-S603-M85, "Standard for Steel Underground Tanks for Flammable and Combustible Liquids", and CAN4-S603.1-M85, "Standard for Galvanic Corrosion Protection Systems for Underground Tanks for Flammable and Combustible Liquids", and CAN4-S631-M84, "Isolating Bushings for Steel Underground Tanks Protected with Coatings and Galvanic Systems"; or

d. National Association of Corrosion Engineers (NACE) Standard RP-02-85, "Control of External Corrosion on Metallic Buried, Partially Buried, or Submerged Liquid Storage Systems" and Underwriters Laboratories Standard 58, "Standard for Steel Underground Tanks for Flammable and Combustible Liquids";

(c) The tank is constructed of a steel-fiberglass-reinforced-plastic composite and complies with one of the following standards:

1. Underwriters Laboratories Standard 1746, "Corrosion Protection Systems for Underground Storage Tanks";

2. Association for Composite Tanks Standard ACT-100, "Specification for the Fabrication of FRP Clad/Composite Underground Storage Tanks;" or

3. Standard STI F894, "Specification for External Corrosion Protection of FRP Composite Steel Underground Storage Tanks";

(d) The tank has been previously used but has been upgraded and certified by the manufacturer as meeting the appropriate standards specified in this subsection; or

(e) The tank construction and corrosion protection are determined by the department to be designed to prevent the release or threatened release of any stored regulated substance in a manner that is no less protective of human health and the environment than pars. (a) to (d).

(2) PIPING. The piping that routinely contains regulated substances and is in contact with the ground shall be properly designed, constructed, and protected from corrosion in accordance with a code of practice developed by a nationally recognized association or independent testing laboratory as specified below:

(a) The piping is constructed of fiberglass-reinforced plastic complying with one of the following standards:

1. Underwriters Laboratories Subject 971;

2. Underwriters Laboratories Standard 567, "Pipe Connectors for Flammable and Combustible and LP Gas";

3. Underwriters Laboratories of Canada Guide ULC Subject C107C, "Guide for Glass Fiber Reinforced Plastic Pipe and Fittings for Flammable Liquids"; and

4. Underwriters Laboratories of Canada Standard CAN4-S633-M84, "Flexible Underground Hose Connectors";

(b) The piping is constructed of steel and cathodically protected in the following manner:

1. The piping is coated with a suitable dielectric material;

2. Field-installed cathodic protection systems are designed by a corrosion expert;

Note: Cathodic protection systems for new piping designed and installed in accordance with the Petroleum Equipment Institute Standard PEI RP/100 is equivalent to a system designed by a corrosion expert.

3. Impressed current systems are designed to allow determination of current operating status as required in s. ILHR 10.55 (3); and

4. Cathodic protection systems are operated and maintained in accordance with s. ILHR 10.55 and the piping complies with the following standards:

a. National Fire Protection Association Standard 30, "Flammable and Combustible Liquids Code";

b. American Petroleum Institute Publication 1615, "Installation of Underground Petroleum Storage Systems";

c. American Petroleum Institute Publication 1632, "Cathodic Protection of Underground Petroleum Storage Tanks and Piping Systems";

d. National Association of Corrosion Engineers Standard RP-01-69, "Control of External Corrosion on Submerged Metallic Piping Systems"; and

e. Steel Tank Institute Standard STI R892 "Recommended Practice for Corrosion Protection of Underground Piping Networks Associated with Liquid Storage and Dispensing Systems."

(c) The piping is constructed of metal without additional corrosion protection measures provided that:

1. The piping is installed at a site that is determined by a corrosion expert to not be corrosive enough to cause it to have a release due to corrosion during its operational life; and

2. Owners and operators maintain records that demonstrate compliance with the requirements of subd. 1. for the remaining life of the piping and the piping complies with the following standards:

a. National Fire Protection Association Standard 30, "Flammable and Combustible Liquids Code"; and

b. National Association of Corrosion Engineers Standard RP-01-69, "Control of External Corrosion on Submerged Metallic Piping Systems"; or

(d) The piping construction and corrosion protection are determined by the department to be designed to prevent the release or threatened release of any stored regulated substance in a manner that is no less protective of human health and the environment than the requirements in pars. (a) to (c).

(e) Flex connectors shall be used in place of swing joints at the following locations:

1. At the top of the tank;
2. Between the tank and the vent pipe;
3. Below the dispenser; and
4. In fiberglass pipe where there is less than 4 feet between turns.

(2m) ACCESS MANWAYS. (a) All new underground storage tank systems shall be provided with a passageway to provide access to connections between all piping, venting and the tank.

(b) The access passageway shall be of sufficient size to allow access, maintenance, service, disconnection and connection of system appurtenances.

(3) SPILL AND OVERFILL PREVENTION EQUIPMENT. (a) Except as provided in par. (b), to prevent spilling and overflowing associated with product transfer to the UST system, owners and operators shall use the following spill and overflow prevention equipment:

1. Spill prevention equipment that will prevent release of product to the environment when the transfer hose is detached from the fill pipe, such as a spill catchment basin; and

2. Overflow prevention equipment that will:

a. Restrict flow 30 minutes prior to overflowing; or

b. Alert the operator with a high level alarm one minute before overflowing; or

c. Automatically shut off flow into the tank so that none of the fittings located on top of the tank are exposed to product due to overflowing.

(b) Owners and operators are not required to use the spill and overflow prevention equipment specified in par. (a) if:

1. Alternative equipment is used that is determined by the department to be no less protective of human health and the environment than the equipment specified in par. (a); or

2. The UST system is filled by transfers of no more than 25 gallons at one time.



(4) INSTALLATION. (a) All tanks and piping shall be installed by a certified installer according to the manufacturer's instructions and shall comply with one of the following standards:

1. American Petroleum Institute Publication 1615, "Installation of Underground Petroleum Storage Systems";

2. Petroleum Equipment Institute Publication RP100, "Recommended Practices for Installation of Underground Liquid Storage Systems"; or

3. American National Standards Institute Standard B31.3, "Petroleum Refinery Piping", and American National Standards Institute Standard B31.4 "Liquid Petroleum Transportation Piping System".

(b) 1. Tanks shall be subjected to air pressure and soap test after unloading. Tanks that have leak detection provided through inventory control and tightness testing, groundwater or vapor monitoring shall be tightness tested by a certified tightness tester before the tanks are placed in service.

2. Tanks that have leak detection provided by interstitial monitoring or electronic tank gauging shall have the leak detection system certified as operable prior to placing the tanks in service.

3. Piping shall be shown to be leak free by testing prior to backfilling and after backfilling. Pressure piping, or suction piping with a check valve located at the tank, shall pass a tightness test prior to placing the piping in service. If a leak detector is installed on the piping that meets s. ILHR 10.61 (8)(a), the tightness test may be omitted.

(5) CERTIFICATION OF INSTALLATION. All owners and operators shall ensure that one or more of the following methods of certification, testing or inspection is used to demonstrate compliance with sub. (4) by providing a certification of compliance on the UST notification form in accordance with s. ILHR 10.53:

(a) A department certified inspector or installer certifies that the installation complies with the requirements of this chapter.

(b) The owner and operator have complied with another method for ensuring compliance with sub. (4) that is determined by the department to be no less protective of human health and the environment.

ILHR 10.52 UPGRADING OF EXISTING UST SYSTEMS. (1) ALTERNATIVES ALLOWED. No later than December 22, 1998, all existing UST systems shall comply with one of the following requirements:

(a) New UST system performance standards under s. ILHR 10.51;

(b) The upgrading requirements in subs. (2) to (4); or

(c) Closure requirements under Part 7, including applicable requirements for corrective action under Part 6.

(1m) EXCEPTION FOR EXISTING TANKS OF AIRPORT HYDRANT FUEL DISTRIBUTION SYSTEMS. Existing underground storage tanks of airport hydrant fuel distribution systems shall comply with sub. (1) no later than 10 years after the effective date of this chapter.

(2) TANK UPGRADING REQUIREMENTS. Steel tanks shall be upgraded to meet one of the following requirements in accordance with a code of practice developed by a nationally recognized association or independent testing laboratory:

(a) Interior lining. A tank may be upgraded by internal lining if:

1. The lining is installed by a certified tank liner in accordance with the applicable requirements of s. ILHR 10.57 and the site is assessed in accordance with 10.734; and

2. Within 10 years after lining, and every 5 years thereafter, the lined tank is internally inspected and found to be structurally sound with the lining still performing in accordance with original design specifications.

(b) Cathodic protection. A tank may be upgraded by cathodic protection if the cathodic protection system meets the requirements of s. ILHR 10.51 (1)(b) 2. to 4. and the integrity of the tank is ensured using one of the following methods:

1. The tank is internally inspected and assessed to ensure that the tank is structurally sound and free of corrosion holes prior to installing the cathodic protection system;

2. The tank has been installed for less than 10 years and is monitored monthly for releases in accordance with s. ILHR 10.61 (4) to (8);

3. The tank has been installed for less than 10 years and is assessed for corrosion holes by conducting two tightness tests that meet the requirements of s. ILHR 10.61 (3). The tests shall be performed by a certified UST system tightness tester. The first tightness test shall be conducted prior to installing the cathodic protection system. The second tightness test shall be conducted between three and six months following the first operation of the cathodic protection system; or

4. The tank is assessed for corrosion holes by a method that is determined by the department to prevent releases in a manner that is no less protective of human health and the environment than subs. 1. to 3.

(c) Internal lining combined with cathodic protection. A tank may be upgraded by both internal lining and cathodic protection if:

1. The lining is installed by a certified liner in accordance with the applicable requirements of s. ILHR 10.57 and the site is assessed in accordance with 10.734; and

2. The cathodic protection system meets the requirements of s. ILHR 10.51 (1) (b) 2. to 4.

(d) National Standards. The applicable portions of the following codes and standards shall be used to comply with this subsection:

1. American Petroleum Institute Publication 1631, "Recommended Practice for the Interior Lining of Existing Steel Underground Storage Tanks";
2. National Leak Prevention Association Standards 631, "Spill Prevention, Minimum 10 Year Life Extension of Existing Steel Underground Tanks by Lining Without the Addition of Cathodic Protection", and 632 "Internal Inspection of Steel Tanks for Upgrading with Cathodic Protection Without Internal Lining."
3. National Association of Corrosion Engineers Standard RP-02-85, "Control of External Corrosion on Metallic Buried, Partially Buried, or Submerged Liquid Storage Systems"; and
4. American Petroleum Institute Publication 1632, "Cathodic Protection of Underground Petroleum Storage Tanks and Piping Systems."

(3) PIPING UPGRADING REQUIREMENTS. Metal piping that routinely contains regulated substances and is in contact with the ground shall be cathodically protected in accordance with a code of practice developed by a nationally recognized association or independent testing laboratory and shall meet the requirements of s. ILHR 10.51 (2) (b) 2. to 4. The codes and standards listed in s. ILHR 10.51 (2)(b) shall be used to comply with this subsection. The system upgrade shall be designed by a corrosion expert.

(4) SPILL AND OVERFILL PREVENTION EQUIPMENT. To prevent spilling and overfilling associated with product transfer to the UST system, all existing UST systems shall comply with new UST system spill and overfill prevention equipment requirements specified in s. ILHR 10.51 (3).

### PART 3 - GENERAL OPERATING REQUIREMENTS

ILHR 10.54 SPILL AND OVERFILL CONTROL. (1) Owners and operators shall ensure that releases due to spilling or overfilling do not occur. The owner and operator shall ensure that the volume available in the tank is greater than the volume of product to be transferred to the tank before the transfer is made and that the transfer operation is monitored constantly to prevent overfilling and spilling.

Note: The transfer procedures described in NFPA 385 may be used as guidelines for compliance with this subsection. API publication 1621, "Recommended Practice for Bulk Liquid Stock Control at Retail Outlets" and NFPA 30 provide further guidance on the matter of spill and overfill prevention.

(2) The owner and operator shall report, investigate and clean up any spills and overfills in accordance with s. ILHR 10.66 and 10.67.

ILHR 10.55 OPERATION AND MAINTENANCE OF CORROSION PROTECTION. All owners and operators of steel UST systems with corrosion protection shall comply with the following requirements to ensure that releases due to corrosion are prevented for as long as the UST system is used to store regulated substances:

(1) All corrosion protection systems shall be operated and maintained to continuously provide corrosion protection to the metal components of that portion of the tank and piping that routinely contain regulated substances and are in contact with the ground.

(2) All UST systems equipped with cathodic protection systems shall be inspected for proper operation in accordance with the following requirements:

(a) All cathodic protection systems shall be tested by a cathodic protection tester within 6 months of installation and at least every 3 years thereafter or according to another reasonable time frame established by the department; and

(b) The criteria that are used to determine that cathodic protection is adequate as required by this section shall be in accordance with the National Association of Corrosion Engineers Standard RP-02-85, "Control of External Corrosion on Metallic Buried, Partially Buried, or Submerged Liquid Storage Systems."

(3) UST systems with impressed current cathodic protection systems shall also be inspected every 60 days to ensure the equipment is running properly.

(4) For UST systems using corrosion protection, records of the operation of the cathodic protection shall be maintained in accordance with s. ILHR 10.58 to demonstrate compliance with the performance standards in this section. These records shall provide the following:

(a) The results of the last 3 inspections required in sub. (3); and

(b) The results of testing from the last 2 inspections required in sub. (2).

ILHR 10.56 COMPATIBILITY. Owners and operators shall use an UST system made of or lined with materials that are compatible with the substance stored in the UST system.

Note: Owners and operators storing alcohol blends may use the following codes to comply with the requirements of this section:

(A) American Petroleum Institute Publication 1626, "Storing and Handling Ethanol and Gasoline-Ethanol Blends at Distribution Terminals and Service Stations"; and

(B) American Petroleum Institute Publication 1627, "Storage and Handling of Gasoline-Methanol/Cosolvent Blends at Distribution Terminals and Service Stations."

ILHR 10.57 REPAIRS ALLOWED. Owners and operators of UST systems shall ensure that repairs will prevent releases due to structural failure or corrosion as long as the UST system is used to store regulated substances. The repairs shall meet the following requirements:

(1) Repairs to UST systems shall be properly conducted in accordance with the following codes and standards:

(a) National Fire Protection Association Standard 30, "Flammable and Combustible Liquids Code";

(b) American Petroleum Institute Publication 2200, "Repairing Crude Oil, Liquefied Petroleum Gas, and Product Pipelines";

(c) American Petroleum Institute Publication 1631, "Recommended Practice for the Interior Lining of Existing Steel Underground Storage Tanks"; and

(d) National Leak Prevention Association Standard 631, "Spill Prevention, Minimum 10 Year Life Extension of Existing Steel Underground Tanks by Lining Without the Addition of Cathodic Protection."

Note: See s. ILHR 10.734 for additional requirements for tank lining.

(2) Repairs to fiberglass-reinforced plastic tanks may be made by the manufacturer's authorized representatives or in accordance with a code of practice developed by a nationally recognized association or an independent testing laboratory.

(3) Metal pipe sections and fittings that have released product as a result of corrosion or other damage shall be replaced. Fiberglass pipes and fittings may be repaired in accordance with the manufacturer's specifications.

(3m) A site assessment of the piping run is required when repairs are made to the piping or fittings to correct a breach in the integrity of the system.

(4) Repaired tanks and piping shall be tightness tested in accordance with ss. ILHR 10.61 (3) and 10.615 (2) within 30 days following the date of the completion of the repair except as provided in pars. (a) to (c):

(a) The repaired tank is internally inspected in accordance with a code of practice developed by a nationally recognized association or an independent testing laboratory;

(b) The repaired or replaced portion of the UST system is monitored monthly for releases in accordance with a method specified in s. ILHR 10.61 (4) to (8); or

(c) Another test method is used that is determined by the department to be no less protective of human health and the environment than those listed above.

(5) Within 6 months following the repair of any cathodically protected UST system, the cathodic protection system shall be tested in accordance with ss. ILHR 10.55 (2) and (3) to ensure that it is operating properly.

(6) UST system owners and operators shall maintain records of each repair for the remaining operating life of the UST system that demonstrate compliance with the requirements of this section.

ILHR 10.58 REPORTING AND RECORDKEEPING. Owners and operators of UST systems shall cooperate fully with inspections, monitoring and testing conducted by the department, as well as requests for document submission, testing, and monitoring by the owner or operator pursuant to section 9005 of Subtitle I of the Resource Conservation and Recovery Act, as amended.

Note: The recordkeeping and reporting requirements listed below have been approved by the Office of Management and Budget of the Federal Government and have been assigned OMB Control No. 2050-0068.

(1) REPORTING TO THE DEPARTMENT. Owners and operators shall submit the following information to the department:

(a) Notification for all UST systems, which includes certification of installation for new UST systems within 30 days of installation; and

Note: Completion and submittal of the Underground Storage Tank Registration Form (SBD-7437) and the Underground Storage Tank Inspection Checklist (SBD-6294) is sufficient for compliance with paragraph (a). See ss. A10.13 and A10.18 of the Appendix for examples of these forms.

(b) A notification before permanent closure or change-in-service shall be made to the authorized agent.

Note: Owners and operators must submit the following information to the department of natural resources: reports of all releases including suspected releases, spills and overfills, and confirmed releases; and corrective actions planned or taken including initial abatement measures, initial site characterization, free product removal, investigation of soil and groundwater cleanup, and corrective action plan.

(2) RECORDKEEPING. Owners and operators shall maintain the following information:

(a) A corrosion expert's analysis of site corrosion potential if corrosion protection equipment is not used;

(b) Documentation of operation of corrosion protection equipment;

(c) Documentation of UST system repairs;

(d) Compliance with release detection requirements; and

(e) Results of the site investigation conducted at permanent closure.

(3) AVAILABILITY AND MAINTENANCE OF RECORDS. Owners and operators shall keep the required records at the UST site and immediately available for inspection by the department.

#### PART 4 - RELEASE DETECTION

ILHR 10.59 GENERAL REQUIREMENTS FOR ALL UST SYSTEMS. (1) Owners and operators of new and existing UST systems shall provide a method, or combination of methods, of release detection that:

(a) Can detect a release from any portion of the tank and the connected underground piping that would routinely contain product if the tank were 95% full.

(b) Is installed, calibrated, operated, and maintained in accordance with the manufacturer's instructions, including routine maintenance and service checks for operability or running condition; and

(c) Meets the performance requirements in s. ILHR 10.61 or 10.615, with any performance claims and their manner of determination described in writing by the equipment manufacturer or installer. Manufacturers of leak detection methods shall specify what threshold test result obtained with their test methods indicates that a release may have occurred.

Note: When a release detection method operated in accordance with the performance standards in ss. ILHR 10.61 and 10.615 indicates a release may have occurred, owners and operators must notify the department of natural resources in accordance with Part 5.

(2) Owners and operators of all UST systems shall comply with the release detection requirements of this part by December 22 of the year listed in Table 10.59. Except that USTs of airport hydrant fuel distribution systems and UST systems which store fuel solely for use by emergency power generators shall comply with the release detection requirements of this part by the dates specified in Table 10.773 (1).

(3) Any existing UST system that cannot apply a method of release detection that complies with this part shall complete the closure procedures in Part 7 by the date on which release detection is required for that UST system under sub. (2).

TABLE 10.59

Schedule for Phase-in of Release Detection

| Year System Was Installed      | Year When Release Detection is Required (by December 22 of the year indicated) |      |      |      |                               |
|--------------------------------|--|------|------|------|-------------------------------|
|                                | 1989   | 1990 | 1991 | 1992 | 1993                          |
| Before 1965 or date unknown    | RD   | P    |      |      |                               |
| 1965-1969                      |  | P/RD |      |      |                               |
| 1970-1974                      |  | P    | RD   |      |                               |
| 1975-1979                      |  | P    |      | RD   |                               |
| 1980-1988                      |  | P    |      |      | RD                            |
| Tanks Installed After 12/22/88 |  |      |      |      | Immediately upon installation |

P = Shall begin release detection for all pressurized piping in accordance with ss. ILHR 10.60 (2)(a) and 10.605 (2)(d).

RD = Shall begin release detection for tanks and suction piping in accordance with ss. ILHR 10.60 (1), 10.60 (2)(b) and 10.605.

ILHR 10.60 REQUIREMENTS FOR PETROLEUM UST SYSTEMS. Owners and operators of petroleum UST systems shall provide release detection for tanks and piping as follows:

(1) TANKS. Tanks shall be monitored at least every 30 days for releases using one of the methods listed in ss. ILHR 10.61 (4) to (8) except that:

(a) UST systems that meet the performance standards in s. ILHR 10.51 or 10.52, and the monthly inventory control requirements in s. ILHR 10.61 (1) or (2), may use tank tightness testing conducted in accordance with s. ILHR 10.61 (3) at least every 5 years until December 22, 1998, or until 10 years after the tank is installed or upgraded under s. ILHR 10.52 (2), whichever is later;



(b) UST systems that do not meet the performance standards in s. ILHR 10.51 or 10.52 may use monthly inventory controls conducted in accordance with s. ILHR 10.61 (1) or (2) and annual tank tightness testing conducted in accordance with s. ILHR 10.61 (3) until December 22, 1998, when the tank shall be upgraded under s. ILHR 10.52 or permanently closed under s. ILHR 10.732; and

(c) Tanks with capacity of 1,000 gallons or less may use weekly tank gauging conducted in accordance with s. ILHR 10.61 (2).

(d) Release detection systems for compartmentalized tanks shall be capable of detecting releases between compartments.

(2) PIPING. Underground piping that routinely contains regulated substances shall be monitored for releases in a manner that meets one of the following requirements:

(a) Pressurized piping. Underground piping that conveys regulated substances under pressure shall:

1. Be equipped with an automatic line leak detector in accordance with s. ILHR 10.615 (1); and

2. Have an annual line tightness test conducted in accordance with s. ILHR 10.615 (2) or have monthly monitoring conducted in accordance with s. ILHR 10.615 (3).

(b) Suction piping. Underground piping that conveys regulated substances under suction shall either have a line tightness test conducted at least every 3 years and in accordance with s. ILHR 10.615 (2), or use a monthly monitoring method conducted in accordance with s. ILHR 10.615 (3). No release detection is required for suction piping that is designed and constructed to meet the following standards:

1. The below-grade piping operates at less than atmospheric pressure;

2. The below-grade piping is sloped so that the contents of the pipe will drain back into the storage tank if the suction is released;

3. Only one check valve is included in each suction line;

4. The check valve is located directly below and as close as practical to the suction pump; and

5. A method is provided that allows compliance with subds. 2. to 4. to be readily determined.

ILHR 10.605 REQUIREMENTS FOR HAZARDOUS SUBSTANCE UST SYSTEMS. Owners and operators of hazardous substance UST systems shall provide release detection that meets the following requirements:

(1) Release detection at existing UST systems shall meet the requirements for petroleum UST systems in s. ILHR 10.60. By December 22, 1998, all existing hazardous substance UST systems shall meet the release detection requirements for new systems in sub. (2).

(2) Release detection at new hazardous substance UST systems shall meet the following requirements:

(a) Secondary containment systems shall be designed, constructed and installed to:

1. Contain regulated substances released from the tank system until they are detected and removed;
2. Prevent the release of regulated substances to the environment at any time during the operational life of the UST system; and
3. Be checked for evidence of a release at least every 30 days.

Note: The provisions of 40 CFR 265.193, Containment and Detection of Releases, may be used to comply with these requirements.

(b) Double-walled tanks shall be designed, constructed, and installed to:

1. Contain a release from any portion of the inner tank within the outer wall; and
2. Detect the failure of the inner or exterior wall.

(c) External liners, including vaults, shall be designed, constructed, and installed to:

1. Contain 100 percent of the capacity of the largest tank within its boundary;
2. Prevent the interference of precipitation or groundwater intrusion with the ability to contain or detect a release of regulated substances; and
3. Surround the tank completely and be capable of preventing lateral as well as vertical migration of regulated substances.

(d) Underground piping shall be equipped with secondary containment that satisfies the requirements of par. (a), such as trench liners and jacketing of double-walled pipe. In addition, underground piping that conveys regulated substances under pressure shall be equipped with an automatic line leak detector in accordance with s. ILHR 10.615 (1).

(e) Other methods of release detection may be used if owners and operators:

1. Demonstrate to the department that an alternate method can detect a release of the stored substance as effectively as any of the methods allowed in ss. ILHR 10.61 (2) to (8) can detect a release of petroleum;
2. Provide information to the department on effective corrective action technologies, health risks, and chemical and physical properties of the stored substance, and the characteristics of the UST site; and

3. Obtain approval from the department to use the alternate release detection method before the installation and operation of the new UST system.

ILHR 10.61 METHODS OF RELEASE DETECTION FOR TANKS. Each method of release detection for tanks used to meet the requirements of s. ILHR 10.60 shall be conducted in accordance with this section. All volumetric tank tightness test methods, nonvolumetric tank tightness test methods, automatic tank gauging systems, liquid-phase out-of-tank product detectors, vapor-phase out-of-tank product detectors, and statistical inventory reconciliation methods shall be evaluated in accordance with the appropriate EPA standard test procedure for evaluating leak detection methods and shall be approved by the department in accordance with ILHR 10.125.

(1) INVENTORY CONTROL. Product inventory control or another test of equivalent performance shall be conducted monthly and reconciled to detect a release of at least 1.0 percent of flow-through plus 130 gallons on a monthly basis in the following manner:

(a) Inventory volume measurements for regulated substance inputs, withdrawals, and the amount still remaining in the tank are recorded each operating day;

(b) The equipment used is capable of measuring the level of product over the full range of the tank's height to the nearest one-eighth of an inch;

(c) The regulated substance inputs are reconciled with delivery receipts by measurement of the tank inventory volume before and after delivery. Where blend pumps are used, reconciliation may address all tanks as a group rather than individual tanks;

(d) Deliveries are made through a drop tube that extends to within one foot of the tank bottom;

(e) Product dispensing is metered and recorded within the local standards for meter calibration or an accuracy of 6 cubic inches for every 5 gallons of product withdrawn; and

(f) The measurement of any water level in the bottom of the tank is made to the nearest one-eighth of an inch at least once a month.

Note: Practices described in the American Petroleum Institute Publication 1621, "Recommended Practice for Bulk Liquid Stock Control at Retail Outlets," may be used, where applicable, as guidance in meeting the requirements of this subsection.

(2) MANUAL TANK GAUGING. Manual tank gauging shall meet the following requirements:

(a) Tank liquid level measurements shall be taken at the beginning and ending of a period of at least 36 hours during which no liquid is added to or removed from the tank;

(b) Level measurements shall be based on an average of two consecutive stick readings taken at both the beginning and ending of the period;

(c) The equipment used shall be capable of measuring the level of product over the full range of the tank's height to the nearest one-eighth of an inch;

(d) A leak is suspected and subject to the requirements of Part 5 if the variation between beginning and ending measurements exceeds the weekly or monthly standards in the following table:

| <u>Nominal<br/>Tank Capacity</u> | <u>Weekly Standard<br/>(one test)</u> | <u>Monthly Standard<br/>(average of four tests)</u> |
|----------------------------------|---------------------------------------|---|
| 550 gallons or less              | 10 gallons                            | 5 gallons   |
| 551-1000 gallons                 | 13 gallons                            | 7 gallons   |
| 1001-2000 gallons                | 26 gallons                            | 13 gallons  |

(e) Only tanks of 1000 gallons or less nominal capacity may use manual tank gauging as the sole method of release detection. Tanks of 1001 to 2000 gallons may use manual tank gauging in place of manual inventory control in sub. (1). Tanks of greater than 2000 gallons nominal capacity may not use manual tank gauging to meet the leak detection requirements of this part.

(3) TIGHTNESS TESTING. (a) Tightness testing, or another test of equivalent performance, shall be capable of detecting a 0.1 gallon per hour leak rate from any portion of the tank that routinely contains product when the tank is 95% full with a probability of detection of 0.95 and probability of false alarm of 0.05.

(b) The test methods shall be capable of detecting the minimum leak rate with the required probability of detection under false alarm, while accounting for the effects of thermal expansion or contraction of the product, vapor pockets, tank deformation, evaporation or condensation, and the location of the water table. Tightness testing shall be conducted by a certified tightness tester.

(4) AUTOMATIC TANK GAUGING. Equipment for automatic tank gauging that tests for the loss of product and conducts inventory control shall meet the following requirements:

(a) The automatic product level monitor test can detect a 0.2 gallon per hour leak rate from any portion of the tank that routinely contains product with a probability of detection of 0.95 and probability of false alarm of 0.05;

(b) Inventory control, or another test of equivalent performance, is conducted in accordance with the requirements of sub. (1); and

(c) The system shall be certified as operable prior to being placed in service.

(5) VAPOR MONITORING. Testing or monitoring for vapors in the soil gas of the excavation zone shall meet the following requirements:

(a) The materials used as backfill are sufficiently porous, such as gravel, sand and crushed rock, to readily allow diffusion of vapors from releases into the excavation area;

(b) The stored regulated substance, or a tracer compound placed in the tank system, is sufficiently volatile, such as gasoline, to result in a vapor level that is detectable by the monitoring devices located in the excavation zone in the event of a release from the tank;

(c) The measurement of vapors by the monitoring device is not rendered inoperative by the groundwater, rainfall, or soil moisture or other known interferences so that a release could go undetected for more than 30 days;

(d) The level of background contamination in the excavation zone will not interfere with the method used to detect releases from the tank;

(e) The vapor monitors are designed and operated to detect any significant increase in concentration above background of the regulated substance stored in the tank system, a component or components of that substance, or a tracer compound placed in the tank system;

(f) An assessment is made of the excavation zone to determine the presence of existing soil contamination including free product, absorbed product, and vapors.

(g) The monitoring wells are placed in the backfill around the tanks and piping. All portions of the tank bed are within a 25-foot radius of a monitoring well. One monitoring well is located at the lowest point within the tank bed;

(h) All portions of piping are within the 25-foot detection radius of a vapor monitoring well;

(i) Monitoring wells are clearly marked and secured to avoid unauthorized access and tampering; and

(j) A tightness test of the tanks and piping shall be conducted in accordance with sub. (3) prior to placing tanks in service.

(6) GROUNDWATER MONITORING. Testing or monitoring for liquids on the groundwater shall meet the following requirements:

(a) The regulated substance stored is immiscible in water and has a specific gravity of less than one;

(b) Groundwater is never more than 20 feet from the ground surface and the hydraulic conductivity of the soil between the UST system and the monitoring wells or devices is not less than 0.01 cm/sec;

Note: For example, the soil should consist of well sorted gravel and coarse sands. Hydraulic conductivity should be measured through the use of pump tests, slug tests or permeaters.

(c) Groundwater monitoring wells shall comply with the construction requirements of ch. NR 141.

(d) Monitoring wells or devices intercept the excavation zone or are as close to it as is technically feasible;

(e) The continuous monitoring devices or manual methods used can detect the presence of at least one-eighth of an inch of free product on top of the groundwater in the monitoring wells;

(f) Within and immediately below the UST system excavation zone, the site is assessed to ensure compliance with the requirements in pars. (a) to (e) and to establish the number and positioning of monitoring wells or devices that will detect releases from any portion of the tank that routinely contains product. The assessment shall determine the following:

1. Soil layering and classification of each soil layer capable of affecting product flow.
2. Primary and secondary permeability.
3. Effective porosity of saturated and unsaturated zone.
4. Current depth to water table and the extent of seasonal fluctuations in the water table as evidenced by soil gleying or mottling, nearby monitoring wells, or regional water table information.
5. Presence of utility trenches or other natural or manmade features capable of influencing product movement.
6. Existing soil contamination including free product, absorbed product, and vapors.
7. Groundwater flow directions and method of determination.

(g) Monitoring wells are clearly marked and secured to avoid unauthorized access and tampering; and

(h) A tightness test shall be conducted in accordance with sub. (3) for the tank and piping prior to placing the tank in service.

(6m) UNSATURATED ZONE MONITORING. Approval for the use of unsaturated zone monitoring will be considered by the department on a case-by-case basis in accordance with sub. (8).

(7) INTERSTITIAL MONITORING. Interstitial monitoring between the UST system and a secondary barrier immediately around or beneath it may be used, but only if the system is designed, constructed and installed to detect a leak from any portion of the tank that routinely contains product and also meets one of the following requirements:

(a) For double-walled UST systems, the sampling or testing method can detect a release through the inner wall in any portion of the tank that routinely contains product;

Note: The provisions outlined in the Steel Tank Institute's "Standard for Dual Wall Underground Storage Tanks" may be used as guidance for aspects of the design and construction of underground steel double-walled tanks.

(b) For UST systems with a secondary barrier within the excavation zone, the sampling or testing method used can detect a release between the UST system and the secondary barrier and detection system is constructed as follows:

1. The secondary barrier around or beneath the UST system consists of artificially constructed material that is sufficiently thick and impermeable, at least  $10^{-6}$  cm/sec for the regulated substance stored, to direct a release to the monitoring point and permit its detection;

2. The barrier is compatible with the regulated substance stored so that a release from the UST system will not cause a deterioration of the barrier allowing a release to pass through undetected;

3. For cathodically protected tanks, the secondary barrier shall be installed so that it does not interfere with the proper operation of the cathodic protection system;

4. The groundwater, soil moisture, or rainfall will not render the testing or sampling method used inoperative so that a release could go undetected for more than 30 days;

5. The site is assessed to ensure that the secondary barrier is always above the groundwater and not in a 25-year flood plain, unless the barrier and monitoring designs are for use under such conditions; and

6. Monitoring wells are clearly marked and secured to avoid unauthorized access and tampering.

(c) For tanks with an internally fitted liner, an automated device can detect a release between the inner wall of the tank and the liner, and the liner is compatible with the substance stored; and

(d) The monitoring system shall be certified as operable prior to being placed in service.

(8) OTHER METHODS. Any other type of release detection method, or combination of methods, can be used if:

(a) It can detect a 0.2 gallon per hour leak rate or a release of 150 gallons within a month with a probability of detection of 0.95 and a probability of false alarm of 0.05; or

(b) The department may approve another method if the owner and operator can demonstrate that the method can detect a release as effectively as any of the methods allowed in subs. (3) to (7). In comparing methods, the department shall consider the size of release that the method can detect and the frequency and reliability with which it can be detected. If the method is approved, the owner and operator shall comply with any conditions imposed by the department on its use to ensure the protection of human health and the environment.

ILHR 10.615 METHODS OF RELEASE DETECTION FOR PIPING. Each method of release detection for piping used to meet the requirements of s. ILHR 10.60 shall be conducted in accordance with this section. Pipeline leak detection systems shall be approved by the department in accordance with ILHR 10.125.

(1) AUTOMATIC LINE LEAK DETECTORS. Methods which alert the operator to the presence of a leak by restricting or shutting off the flow of regulated substances through piping or triggering an audible or visual alarm may be used only if they detect leaks of 3 gallons per hour at 10 pounds per square inch line pressure within 1 hour. An annual test of the operation of the leak detector shall be conducted in accordance with the manufacturer's requirements.

(2) LINE TIGHTNESS TESTING. (a) A periodic test of piping may be conducted only if it can detect a 0.1 gallon per hour leak rate at one and one-half times the operating pressure with a probability of detection of 0.95 and a probability of false alarm of 0.05. The test shall be performed by a certified tightness tester.

(b) Where a leak detector is installed on the piping that has the same leak detection capability as the tightness test specified in s. ILHR 10.61 (8)(a), the tightness test may be omitted.

(3) APPLICABLE TANK METHODS. Any of the methods in s. ILHR 10.61 (5) to (8) may be used if they are designed to detect a release from any portion of the underground piping that routinely contains regulated substances.

ILHR 10.625 RELEASE DETECTION RECORDKEEPING. All UST system owners and operators shall maintain records in accordance with s. ILHR 10.58 demonstrating compliance with all applicable requirements of this part. These records shall include the following:

(1) All written performance claims pertaining to any release detection system used, and the manner in which these claims have been justified or tested by the equipment manufacturer or installer, shall be maintained for 10 years from the date of installation;

(2) The results of any sampling, testing, or monitoring shall be maintained for at least 10 years and the results of tightness testing conducted in accordance with s. ILHR 10.61 shall be retained until the next 2 tests are conducted; and

Note: It is suggested that owners and operators retain copies of all release detection recordkeeping. The documentation may be necessary to exclude the site as a possible source of contamination at a later date.

(3) Written documentation of all calibration, maintenance, and repair of release detection equipment permanently located on-site shall be maintained for at least one year after the servicing work is completed, or for another reasonable time period determined by the department. Any schedules of required calibration and maintenance provided by the release detection equipment manufacturer shall be retained for 10 years from the date of installation.



PART 5 - SUSPECTED RELEASE INVESTIGATION AND CONFIRMATION

ILHR 10.63 CONDITIONS INDICATING SUSPECTED RELEASES. Owners and operators of storage tank systems shall follow the procedures in s. ILHR 10.635 when any of the following conditions exist:

(1) Unusual operating conditions observed by owners or operators, such as the erratic behavior of product dispensing equipment, the sudden loss of product from the tank system or an unexplained presence of water in the tank; or

(2) Monitoring results from a release detection method required under ss. ILHR 10.60 and 10.605 indicate that a release may have occurred; or

(3) When ordered by DILHR.

ILHR 10.635 CONFIRMING SUSPECTED RELEASES. (1) Owners and operators shall immediately investigate and confirm all suspected releases within 7 days of discovery of any of the conditions described in s. ILHR 10.63, unless:

(a) System equipment or the monitoring device is found to be defective but not leaking and is immediately repaired, recalibrated or replaced and additional monitoring does not confirm the initial result; or

(b) If inventory control is the method of leak detection, a second month of data does not confirm the initial results; or

(c) Corrective action is initiated in accordance with s. 144.76, Stats.

(2) Unless action under sub. (1) has been taken, owners and operators shall immediately investigate and confirm all suspected releases within 7 days of discovery of any of the conditions described in s. ILHR 10.63 by taking one of the following actions or both at the direction of the department:

(a) SYSTEM TEST. Owners and operators shall conduct tests according to the requirements for tightness testing in ss. ILHR 10.61 (3) and 10.615 (2) that determine whether a leak exists in that portion of the tank or of the delivery system which routinely contains product, or both.

(b) SITE CHECK. Owners and operators shall measure for the presence of a release where contamination is most likely to be present at the tank site. In selecting sample types, sample locations and measurement methods, owners and operators shall consider the nature of the substance stored, the type of initial alarm or cause for suspicion, the type of backfill, the depth to groundwater and other factors appropriate for identifying the presence and source of the release.

(3) Owners and operators of tank systems which are suspected of releasing a regulated substance due to off-site impacts such as the presence of contaminated soils or free product, dissolved phase product or vapors in soils, basements, sewer or utility lines or nearby surface or ground waters, shall follow the procedures of sub. (2) when required to do so by the department or the department of natural resources.

(4) If the results from the system test or site check do not indicate that a release has occurred, further investigation of the incident triggering the suspected release investigation is not required.

ILHR 10.64 RELEASE CONFIRMATION AND REPORTING. (1) Owners and operators shall immediately report any release of a regulated substance to the department of natural resources in accordance with s. 144.76 (2), Stats., and investigate the extent of contamination and undertake corrective action in accordance with s. 144.76 (3), Stats. Releases which must be reported to the department of natural resources under s. 144.76 (2), stats., include the discovery of contaminated soils or free product, dissolved phase product or vapors in soils, basements, sewer or utility lines or surface or groundwaters at the tank site or in the surrounding area and spills or overfills.

Note: Releases of substances defined in section 101 (14) of CERCLA that are not flammable or combustible liquids must also be reported to the department of natural resources in accordance with s. 144.76, Stats.

(2) The release of a regulated substance to the environment which equals or exceeds its reportable quantity under CERCLA (40 CFR Part 302) shall immediately be reported to the U.S. environmental protection agency.

#### PART 6 - EMERGENCY RELEASE RESPONSE

ILHR 10.66 EMERGENCY RELEASE RESPONSE AND ABATEMENT MEASURES. Upon confirmation and reporting of a release, owners and operators shall immediately:

(a) Identify, mitigate and monitor fire, explosion and vapor hazards such as the presence of free product or vapors in subsurface structures and handle all flammable products in a safe and competent manner to prevent fires or explosion;

(b) Take action to prevent any further release of the regulated substance to the environment including:

1. Remove as much of the regulated substance from the tank system as is necessary to prevent further release to the environment;

2. Repair, replace, upgrade or permanently close the tank system if a leak exists;

3. Visually inspect the tank system and any area where a spill or overfill occurred;

4. Identify any free product and remove it to the maximum extent practicable so as to minimize the migration of contamination. The removal shall be conducted in a manner which minimizes the spread of contamination and is appropriate for the hydrogeologic conditions at the site and which properly treats, discharges or disposes of recovered by-products in compliance with all applicable federal, state and local requirements.

(c) Take action to contain the release to prevent migration including managing any contaminated soils that are excavated or exposed in accordance with ch. 144, Stats., and department of natural resources guidelines and any other applicable state or local requirements; and

(d) Measure for the presence of a release where contamination is most likely to be present at the UST site. In selecting sample types, sample locations and measurement methods, owners and operators shall consider the nature of the substance stored, the type of initial alarm or cause for suspicion, the type of backfill, the depth to groundwater and other factors appropriate for identifying the presence and source of the release.

Note: NFPA Standard 329, Recommended Practice for Handling Underground Leakage of Flammable and Combustible Liquids may be used for guidance in the investigation of releases. All tightness testing must be performed in accordance with s. ILHR 10.61 (3) and 10.615 (2).

ILHR 10.67 INVESTIGATION AND CORRECTIVE ACTION. Upon confirmation of a release, owners and operators shall immediately report the release to the department of natural resources in accordance with s. 144.76 (2), Stats., and take the actions determined to be necessary by the department of natural resources to investigate and remediate the impacts of the release in accordance with s. 144.76 (3), Stats.

#### PART 7 - OUT-OF-SERVICE UST SYSTEMS, CLOSURE, AND SITE ASSESSMENT

ILHR 10.73 TEMPORARY CLOSURE. (1) When an UST system is temporarily closed, owners and operators shall continue operation and maintenance of corrosion protection in accordance with s. ILHR 10.55, and any release detection in accordance with Part 4. Parts 5 and 6 shall be complied with if a release is suspected or confirmed. However, release detection is not required as long as the UST system is empty. The UST system is empty when all materials have been removed using commonly employed practices so that no more than one inch of residue, or 0.3 percent by weight of the total capacity of the UST system, remain in the system.

(2) When an UST system is temporarily closed for 3 months or more, owners and operators shall also comply with the following requirements:

(a) Leave vent lines open and functioning; and

(b) Cap and secure all other lines, pumps, manways, and ancillary equipment.

(3) Any leak detection testing requirement which was required during closure should be complied with prior to placing the tank back in service.

(4) When an UST system is temporarily closed for more than 12 months, owners and operators shall permanently close the UST system if it does not meet either performance standards in s. ILHR 10.51 for new UST systems or the upgrading requirements in s. ILHR 10.52, except that the spill and overfill equipment requirements of ss. ILHR 10.51 (3) or 10.52 (4) do not have to be met. Owners and operators shall permanently close the substandard UST systems

at the end of this 12-month period in accordance with ss. ILHR 10.732 to 10.738, unless the department provides an extension of the 12-month temporary closure period. Owners and operators shall complete a site assessment in accordance with s. ILHR 10.734 before such an extension can be applied for.

ILHR 10.731 SELDOM USED TANKS. Except for oil tanks used for emergency and backup fuel or overflow tanks, UST systems shall be considered to be abandoned and therefore subject to closure in accordance with s. ILHR 10.730 or 10.732 unless product transfers are made to or from the system periodically.

(1) Transfers shall be made to and from motor fuel tanks at least once in any 180 day period to be considered in use.

(2) Transfers shall be made to and from heating oil tanks at least once in any 1 year period to be considered in use.

(3) Inventory records, manifests, or paid receipts for product received will be acceptable to the department as proof that transfers are being made.

(4) UST system owners and operators may make written requests to the department for approval for less frequent use if it is justified as a part of the tank's purpose.

ILHR 10.732 PERMANENT CLOSURE AND CHANGES-IN-SERVICE. (1) At least 15 days before beginning either permanent closure or a change-in-service under subs. (2) or (3) or within another reasonable time period determined by the department, owners and operators shall notify the authorized agent of their intent to permanently close or make the change-in-service, unless such action is in response to corrective action. A site assessment of the excavation zone in accordance with s. ILHR 10.734 shall be performed after notifying the authorized agent but before completion of the permanent closure or a change-in-service.

(2) (a) To permanently close a UST system, owners and operators shall empty and clean it by removing all liquids and accumulated sludges and remove it from the ground. Cleaning of the tank shall be performed by a certified cleaner. Removal of tanks and other portions of UST systems shall be performed by a certified remover. Tanks shall be made inert so that the composition of the atmosphere inside the tank is 10% of the lower explosive limit for the stored product prior to bringing the tank aboveground or performing any other work on the tank.

(b) If removal of the tanks from the ground would affect the structural integrity of a building or the fire chief or authorized agent determines a condition of hardship to exist, the tank may be abandoned in place and filled with an inert solid material after emptying and cleaning in accordance with par. (a).

(3) Continued use of an UST system to store a nonregulated substance is considered a change-in-service. Before a change-in-service, owners and operators shall empty and clean the tank by removing all liquid and accumulated sludge and conduct a site assessment in accordance with s. ILHR 10.734. Cleaning of tanks and site assessments shall be performed by persons certified by the department.

Note: The following cleaning and closure procedures may be used as guidance for compliance with this section:

(A) American Petroleum Institute Recommended Practice 1604, "Removal and Disposal of Used Underground Petroleum Storage Tanks";

(B) American Petroleum Institute Publication 2015, "Cleaning Petroleum Storage Tanks";

(C) American Petroleum Institute Recommended Practice 1631, "Interior Lining of Underground Storage Tanks"; and

(D) The National Institute for Occupational Safety and Health "Criteria for a Recommended Standard...Working in Confined Space."

(E) National Leak Prevention Association standard 631 "Spill Prevention, minimum 10 year life extension of existing steel underground storage tanks by lining without the addition of cathodic protection," and,

(F) Chapter ILHR 31 "Confined Spaces".

ILHR 10.734 SITE ASSESSMENT. (1) GENERAL. When a site assessment is required by this chapter, or when directed by the department, owners and operators must measure for the presence of a release where contamination is identified or is most likely to be present at the UST site.

(2) EXCEPTIONS. (a) A site assessment shall not be required for tanks that are closed or undergo a change-in-service if one of the external release detection methods allowed in ss. ILHR 10.61 (5) and (6) is operating in accordance with the requirements of s. ILHR 10.61 at the time of closure and indicates that no release has occurred.

(b) A site assessment shall not be required for tanks which are lined if a visual internal inspection is made and no holes and no rust plugs are found during the lining process.

(3) SAMPLING AND MEASUREMENTS. In selecting sample types, sample locations, and measurement methods, owners and operators must consider the method of closure, the nature of the stored substance, the type of backfill, the depth to groundwater, and other factors appropriate for identifying the presence of a release. Site assessments shall be performed by persons certified by the department.

Note: Use of the closure assessment procedures specified in Appendix B will be acceptable to the department as compliance with this subsection.

(4) DETECTION OF RELEASE. If contaminated soils, contaminated groundwater or free product as a liquid or vapor is discovered while assessing the site, or by any other manner, owners and operators must begin corrective action in accordance with part 6.

ILHR 10.736 APPLICABILITY TO PREVIOUSLY CLOSED UST SYSTEMS.

(1) GENERAL. When directed by the department, the owner and operator of an UST system permanently closed before December 22, 1988, shall assess the excavation zone and close the UST system in accordance with this part if releases from the UST may, in the judgment of the department, pose a current or potential threat to human health and the environment.

(2) SYSTEMS PREVIOUSLY CLOSED WITHOUT SOLID INERT FILL. (a) The owner and operator of an UST system which was permanently closed before September 1, 1971, without removing the tank from the ground but by filling the tank with water, shall bring the closed system into compliance with s. ILHR 10.732 except that the site assessment specified by s. ILHR 10.734 is not required. Written documentation shall be provided to prove closure with water prior to September 1, 1971. Compliance with this section shall be completed within 3 years after the effective date of this chapter.

Note: Prior to September 1, 1971, Ch. Ind. 8, Flammable and Combustible Liquids Code allowed UST systems to be filled with water when closed or abandoned in place.

(b) Empty or improperly closed or abandoned tanks which do not meet the requirements of par. (a) shall be permanently closed in accordance with all of the provisions of this part.

ILHR 10.738 CLOSURE RECORDS. Owners and operators shall maintain records in accordance with s. ILHR 10.58 that are capable of demonstrating compliance with closure requirements under this part. The results of the excavation zone assessment required in s. ILHR 10.734 shall be maintained for at least 3 years after completion of permanent closure or change-in-service in one of the following ways:

- (1) By the owners and operators who took the UST system out of service;
- or
- (2) By the current owners and operators of the UST system site.

SUBCHAPTER VII - GROUNDWATER PROTECTION FOR SMALL FARM AND RESIDENTIAL MOTOR FUEL USTS AND FOR HEATING OIL USTS

(Farm and Residential Underground Storage Tanks of 1100 Gallons or Less Capacity Used for Storage of Motor Fuel for Noncommercial Purposes; Underground Storage Tanks Used for Storing Heating Oil for Consumptive Use on the Premises Where Stored.)

PART 1 - PROGRAM SCOPE

ILHR 10.74 SCOPE. This subchapter applies to the following:

- (1) Farm and residential underground storage tank systems of 1100 gallons or less capacity used for storing motor fuel for noncommercial purposes; and

(2) Underground storage tank systems used for storing heating oil for consumptive use on the premises.

## PART 2 - NOTIFICATION AND REGISTRATION

ILHR 10.75 NEW AND REPLACEMENT STORAGE TANKS SYSTEM REGISTRATION. The owner of all new and replacement storage tanks within the scope of this subchapter shall register the storage tank as specified in s. ILHR 10.13.

ILHR 10.76 EXISTING STORAGE TANK SYSTEM REGISTRATION. The owners of existing storage tanks within the scope of this subchapter who have not registered their tanks as of the effective date of this chapter shall register the storage tanks as specified in s. ILHR 10.14.

## PART 3 - UST SYSTEM DESIGN CONSTRUCTION, INSTALLATION, RELEASE DETECTION, MAINTENANCE AND REPAIR

ILHR 10.77 PERFORMANCE STANDARDS FOR NEW UST SYSTEMS. New and replacement UST systems included in the scope of this chapter shall comply with the performance standards of s. ILHR 10.51, except that spill and overfill equipment specified under s. ILHR 10.51 (3), shall not be required for heating oil UST systems of 4000 gallons or less capacity. Vent whistles shall be provided for heating oil UST systems of 4000 gallons or less capacity.

ILHR 10.771 UPGRADING OF EXISTING UST SYSTEMS. (1) No later than 10 years after the effective date of this chapter all existing farm and residential motor fuel UST systems and all existing heating oil UST systems greater than 4000 gallons in capacity included in the scope of this subchapter shall comply with s. ILHR 10.52 (1) or be permanently closed.

(2) All heating oil UST systems of 4000 gallons or less capacity included in the scope of this subchapter shall no later than 10 years after the effective date of this chapter start a release detection program which complies with the minimum standards established in s. ILHR 10.773 (2)(a) or be permanently closed or upgraded to comply with s. ILHR 10.52 (1) no later than 15 years after the effective date of this chapter.

ILHR 10.772 GENERAL OPERATING REQUIREMENTS. All UST systems included in the scope of this subchapter shall comply with the general operating requirements of s. ILHR 10.54 to s. ILHR 10.58.

ILHR 10.773 RELEASE DETECTION (1) RELEASE DETECTION FOR HEATING OIL UST SYSTEMS OF MORE THAN 4000 GALLONS CAPACITY. Heating oil UST systems that are more than 4000 gallons capacity shall comply with the release detection requirements of ss. ILHR 10.59 to 10.625 except that the compliance dates for the installation of required release detection systems shall be those specified in Table s. ILHR 10.773 (1).

(2) RELEASE DETECTION FOR HEATING OIL UST SYSTEMS OF 4000 GALLONS OR LESS CAPACITY. (a) Existing Systems. Existing heating oil UST systems of 4000 gallons or less capacity shall comply with either: 1. No later than 10 years after the effective date of this chapter, the owner of a heating oil UST system of 4000 gallons or less capacity shall implement a program of tightness testing with testing beginning in the 10th year and every 2 years thereafter; or

2. May implement a release detection program in accordance with ss. ILHR 10.59 to 10.625 beginning in the 10th year; or

3. If the owner elects not to conduct release detection specified under 1. or 2., all heating oil UST systems of 4000 gallons or less capacity shall be permanently closed or upgraded in accordance with the requirements of s. ILHR 10.52 (1)(a), (b), or (c) no later than 15 years after the effective date of this chapter. If the requirement for release detection as specified in 1. or 2. is not met, the system shall be permanently closed or upgraded in accordance with s. ILHR 10.52 (1)(a), (b), or (c) by the end of the 15th year.

(b) New systems. Heating oil UST systems of 4000 gallons or less capacity that are installed on or after the effective date of this chapter shall comply with the release detection requirements of ss. ILHR 10.59 to 10.625.

Note: The tightness testing methods used for heating oil UST systems, other than release detection programs specified in ss. ILHR 10.59 to 10.625, must be specifically approved for that use in accordance with s. ILHR 10.125 or s. ILHR 10.61(8).



Table 10.773 (1)

Schedule for Phase-in of Release Detection of

Wisconsin Regulated Tanks

| Year System  | When Release Detection is Required (by the month of the effective date of this chapter of the year indicated) |      |      |      |      |
|--|---|------|------|------|------|
|  | 1991  | 1992 | 1993 | 1994 | 1995 |
| Before 1965 or date unknown                              | RD  | P    |      |      |      |
| 1965-1969  |   | P/RD |      |      |      |
| 1970-1974  |   | P    | RD   |      |      |
| 1975-1979  |   | P    |      | RD   |      |
| 1980-The Effective Date of This Chapter                  |   | P    |      |      | RD   |
| Tanks Installed After the Effective Date of This Chapter | Immediately Upon Installation   |      |      |      |      |

P = Shall begin release detection for all pressurized piping in accordance with ss. ILHR 10.60 (2) (a) and 10.605 (2) (d).

RD = Shall begin release detection for tanks and suction piping in accordance with ss. ILHR 10.60 (1), 10.60 (2)(b) and 10.605.

PART 4 - SUSPECTED RELEASE INVESTIGATION AND CONFIRMATION

ILHR 10.78 GENERAL. All owners of new, replacement and existing storage tank systems within the scope of this subchapter shall comply with the rules of Part 5, Subch. VI as they relate to suspected release investigation and confirmation.

PART 5 - EMERGENCY RELEASE RESPONSE

ILHR 10.79 GENERAL. All owners of storage tank systems within the scope of this subchapter shall comply with the rules of Part 6, Subch. VI as they relate to emergency release response.

PART 6 - OUT-OF-SERVICE STORAGE TANK SYSTEMS,  
CLOSURE, AND SITE ASSESSMENT

ILHR 10.80 TEMPORARY AND PERMANENT CLOSURE AND CHANGE-IN-SERVICE. All owners of storage tank systems within the scope of this subchapter shall comply with ss. ILHR 10.730, 10.731, 10.732 and 10.738 as they relate to changes-in-service, out-of-service storage tank systems and closure of storage tank systems.

ILHR 10.805 SITE ASSESSMENT. All owners of underground heating oil tanks of more than 4000 gallons capacity shall comply with ss. ILHR 10.734 and 10.736 as they relate to site assessment.

SUBCHAPTER VIII - FINANCIAL RESPONSIBILITY

ILHR 10.81 APPLICABILITY. (1) This subchapter applies to owners and operators of all petroleum underground storage tank systems except as otherwise provided in this section.

(2) Owners and operators of petroleum UST systems are subject to this subchapter if they are in operation on or after the date for compliance established in s. ILHR 10.812.

(3) State and federal government entities whose debts and liabilities are the debts and liabilities of a state or the United States are exempt from this subchapter.

(4) This subchapter does not apply to owners and operators of any UST system described in s. ILHR 10.50 (2) or (3).

(5) If the owner and operator of a petroleum underground storage tank are separate persons, only one person is required to demonstrate financial responsibility; however, both parties are liable in event of noncompliance. Regardless of which party complies, the date set for compliance at a particular facility is determined by the characteristics of the owner as set forth in s. ILHR 10.812.

(6) The requirements of this subchapter do not apply to owners and operators of farm and residential underground storage tanks of 1100 gallons or less capacity used for storing motor fuel for noncommercial purposes.

(7) The requirements of this subchapter do not apply to owners and operators of underground storage tanks used for storing heating oil for consumptive use on the premises.

ILHR 10.812 COMPLIANCE DATES. Owners of petroleum underground storage tanks are required to comply with the requirements of this subchapter by the following dates:

(1) All petroleum marketing firms owning 1,000 or more USTs and all other UST owners that report a tangible net worth of \$20 million or more to the U.S. Securities and Exchange Commission, Dun and Bradstreet, the Energy Information Administration, or the Rural Electrification Administration; January 24, 1989.

(2) All petroleum marketing firms owning at least 100 but not more than 999 USTs; October 26, 1989.

(3) All petroleum marketing firms owning at least 13 but not more than 99 USTs at more than one facility; April 26, 1991.

(4) All petroleum UST owners not described in subs. (1), (2) or (3), including all local government entities; October 26, 1991.

ILHR 10.814 DEFINITION OF TERMS In this subchapter:

(1) "Accidental release" means any release of petroleum from an underground storage tank that results in a need for compensation for bodily injury or property damage neither expected nor intended by the tank owner or operator or corrective action, or both.

(2) "Bodily injury" shall have the meaning given to this term by applicable state law; however, this term shall not include those liabilities which, consistent with standard insurance industry practices, are excluded from coverage in liability insurance policies for bodily injury.

(3) "Controlling interest" means direct ownership of at least 50 percent of the voting stock of another entity.

(4) "Department" means the department of industry, labor and human relations.

(5) "Financial reporting year" means the latest consecutive twelve-month period for which any of the following reports is prepared:

(a) A 10-K report submitted to the US Securities and Exchange Commission.

(b) An annual report of tangible net worth submitted to Dun and Bradstreet; or

(c) Annual reports submitted to the Energy Information Administration or the Rural Electrification Administration.

Note: "Financial reporting year" may thus comprise a fiscal or a calendar year period.

(6) "Legal defense cost" means any expense that an owner or operator or provider of financial assurance incurs in defending against claims or actions brought:

(a) By EPA or the department to require corrective action or to recover the costs of corrective action;

(b) By or on behalf of a third party for bodily injury or property damage caused by an accidental release; or

(c) By any person to enforce the terms of a financial assurance mechanism.

(7) "Occurrence" means an accident or a continuous or repeated exposure to conditions, which result in a release from an underground storage tank.

Note: This definition is intended to assist in the understanding of these regulations and is not intended either to limit the meaning of "occurrence" in a way that conflicts with standard insurance usage or to prevent the use of other standard insurance terms in place of "occurrence."

(8) "Owner or operator," when the owner or operator are separate parties, means the party that is obtaining or has obtained financial assurances.

(9) "Petroleum marketing facilities" means all facilities at which petroleum is produced or refined and all facilities from which petroleum is sold or transferred to other petroleum marketers or to the public.

(10) "Petroleum marketing firms" means all firms owning petroleum marketing facilities. Firms owning other types of facilities with USTs as well as petroleum marketing facilities are considered to be petroleum marketing firms.

(11) "Property damage" shall have the meaning given this term by administrative rules of the office of commissioner of insurance. This term shall not include those liabilities which, consistent with standard insurance industry practices, are excluded from coverage in liability insurance policies for property damage. However, such exclusions for property damage shall not include corrective action associated with releases from tanks which are covered by the policy.

(12) "Provider of financial assurance" means an entity that provides financial assurance to an owner or operator of an underground storage tank through one of the mechanisms listed in ss. ILHR 10.82 to 10.836, including a guarantor, insurer, risk retention group, surety, issuer of a letter of credit, issuer of a state-required mechanism, or a state.

(13) "Substantial business relationship" means the extent of a business relationship necessary under Wisconsin law to make a guarantee contract issued incident to that relationship valid and enforceable. A guarantee contract is issued "incident to that relationship" if it arises from and depends on existing economic transactions between the guarantor and the owner or operator.

(14) "Tangible net worth" means the tangible assets that remain after deducting liabilities; the assets do not include intangibles such as goodwill and rights to patents or royalties. In this subsection, "assets" means all existing and all probable future economic benefits obtained or controlled by a particular entity as a result of past transactions.

ILHR 10.816 AMOUNT AND SCOPE OF REQUIRED FINANCIAL RESPONSIBILITY.

(1) Owners or operators of petroleum underground storage tanks shall demonstrate financial responsibility for taking corrective action and for compensating third parties for bodily injury and property damage caused by accidental releases arising from the operation of petroleum underground storage tanks in at least the following per-occurrence amounts:

(a) For owners or operators of petroleum underground storage tanks that are located at petroleum marketing facilities, or that throughput an average of more than 10,000 gallons of petroleum per month based on annual throughput for the previous calendar year; \$1 million.

(b) For all other owners or operators of petroleum underground storage tanks; \$500,000.

(2) Owners or operators of petroleum underground storage tanks shall demonstrate financial responsibility for taking corrective action and for compensating third parties for bodily injury and property damage caused by accidental releases arising from the operation of petroleum underground storage tanks in at least the following annual aggregate amounts:

(a) For owners or operators of 1 to 100 petroleum underground storage tanks; \$1 million.

(b) For owners or operators of 101 or more petroleum underground storage tanks; \$2 million.

(3) For the purposes of subs. (2) and (6) only, "a petroleum underground storage tank" means a single containment unit and does not mean combinations of single containment units.

(4) Except as provided in sub. (5), if the owner or operator uses separate mechanisms or separate combinations of mechanisms to demonstrate financial responsibility in the full amount specified in subs. (1) and (2) for:

(a) Taking corrective action;

(b) Compensating third parties for bodily injury and property damage caused by sudden accidental releases; or

(c) Compensating third parties for bodily injury and property damage caused by nonsudden accidental releases.

(5) If an owner or operator uses separate mechanisms or separate combinations of mechanisms to demonstrate financial responsibility for different petroleum underground storage tanks, the annual aggregate required shall be based on the number of tanks covered by each such separate mechanism or combination of mechanisms.

(6) Owners or operators shall review the amount of aggregate assurance provided whenever additional petroleum underground storage tanks are acquired or installed. If the number of petroleum underground storage tanks for which assurance must be provided exceeds 100, the owner or operator shall demonstrate financial responsibility in the amount of at least \$2 million of annual aggregate assurance by the anniversary of the date on which the mechanism demonstrating financial responsibility became effective. If assurance is being demonstrated by a combination of mechanisms, the owner or operator shall demonstrate financial responsibility in the amount of at least \$2 million of annual aggregate assurance by the first-occurring effective date anniversary of any one of the mechanisms combined, other than a financial test or guarantee, to provide assurance.

(7) The amounts of assurance required under this section exclude legal defense costs.

(8) The required per-occurrence and annual aggregate coverage amounts do not in any way limit the liability of the owner or operator.

ILHR 10.818 ALLOWABLE MECHANISMS AND COMBINATIONS OF MECHANISMS.

(1) Subject to the limitations of subs. (2) and (3), an owner or operator may use any one or combination of the mechanisms listed in ss. ILHR 10.82 to 10.836 to demonstrate financial responsibility under this subchapter for one or more underground storage tanks.

(2) An owner or operator may use a guarantee or surety bond to establish financial responsibility only if the Attorney General has submitted a written statement to the department that a guarantee or surety bond executed as described in this section is a legally valid and enforceable obligation in this state.

(3) An owner or operator may use self-insurance in combination with a guarantee only if, for the purpose of meeting the requirements of the financial test under this subchapter, the financial statements of the owner or operator are not consolidated with the financial statements of the guarantor.

ILHR 10.82 FINANCIAL TEST OF SELF-INSURANCE. (1) An owner or operator, or guarantor, or both, may satisfy the requirements of s. ILHR 10.816 by passing a financial test as specified in this section. To pass the financial test of self-insurance, the owner or operator, or guarantor, or both, shall meet the criteria of sub. (2) or (3) based on year-end financial statements for the latest completed fiscal year.

(2) (a) The owner or operator, or guarantor, or both, shall have a tangible net worth of at least ten times:

1. The total of the applicable aggregate amount required by s. ILHR 10.816, based on the number of underground storage tanks for which a financial test is used to demonstrate financial responsibility to the department;

2. The sum of the corrective action cost estimates, the current closure and post-closure care cost estimates, and amount of liability coverage for which a financial test is used to demonstrate financial responsibility to the department; and

3. The sum of current plugging and abandonment cost estimates for which a financial test is used to demonstrate financial responsibility to the department.

(b) The owner or operator, or guarantor, or both, shall have a tangible net worth of at least \$10 million.

(c) The owner or operator, or guarantor, or both, shall have a letter signed by the chief financial officer as specified in sub. (4).

(d) The owner or operator, or guarantor, or both, shall either:

1. File financial statements annually with the U.S. Securities and Exchange Commission, the Energy Information Administration, or the Rural Electrification Administration; or

2. Report annually the firm's tangible net worth to Dun and Bradstreet, if Dun and Bradstreet has assigned the firm a financial strength rating of 4A or 5A.

(e) The firm's year-end financial statements, if independently audited, may not include an adverse auditor's opinion, a disclaimer of opinion, or a "going concern" qualification.

(3) (a) The owner or operator, or guarantor, or both, shall meet the financial test requirements of 40 CFR 264.147 (f)(1), substituting the appropriate amounts specified in s. ILHR 10.816 (2) (a) and (b) for the "amount of liability coverage" each time specified in that section.

(b) The fiscal year-end financial statements of the owner or operator, or guarantor, or both, shall be examined by an independent certified public accountant and be accompanied by the accountant's report of the examination.

(c) The firm's year-end financial statements may not include an adverse auditor's opinion, a disclaimer of opinion, or a "going concern" qualification.

(d) The owner or operator, or guarantor, or both, shall have a letter signed by the chief financial officer as specified in sub. (4).

(e) If the financial statements of the owner or operator or guarantor, or both are not submitted annually to the U.S. Securities and Exchange Commission, the Energy Information Administration or the Rural Electrification Administration, the owner or operator, or guarantor, or both, shall obtain a special report by an independent certified public accountant stating that:

1. He or she has compared the data that the letter from the chief financial officer specifies as having been derived from the latest year-end financial statements of the owner or operator, or guarantor, or both, with the amounts in such financial statements; and

2. In connection with that comparison, no matters came to his or her attention which caused him or her to believe that the specified data should be adjusted.

(4) To demonstrate that the financial test is met under sub. (2) or (3), the chief financial officer of the owner or operator, or guarantor, shall sign, within 120 days of the close of each financial reporting year, as defined by the twelve-month period for which financial statements used to support the financial test are prepared, a letter worded exactly as follows, except that the instructions in brackets are to be replaced by the relevant information and the brackets deleted:

Letter from Chief Financial Officer

I am the chief financial officer of [insert: name and address of the owner or operator, or guarantor]. This letter is in support of the use of [insert: "the financial test of self-insurance," or "guarantee" or both] to demonstrate financial responsibility for [insert: "taking corrective action" or "compensating third parties for bodily injury and property damage" or both] caused by [insert: "sudden accidental releases" or "nonsudden accidental releases" or both] in the amount of at least [insert: dollar amount] per occurrence and [insert: dollar amount] annual aggregate arising from operating underground storage tanks.

Underground storage tanks at the following facilities are assured by this financial test or a financial test under an authorized State program by this [insert: "owner or operator", or "guarantor" or both]: [List for each facility: the name and address of the facility where tanks assured by this financial test are located, and whether tanks are assured by this financial test. If separate mechanisms or combinations of mechanisms are being used to assure any of the tanks at this facility, list each tank assured by this financial test by the tank identification number provided in the notification submitted.]

A [insert: "financial test," or "guarantee" or both] is also used by this [insert: "owner or operator," or "guarantor"] to demonstrate evidence of financial responsibility in the following amounts under other EPA regulations or state programs authorized by EPA under 40 CFR Parts 271 and 145:

| EPA Regulations                              | Amount   |
|--|----------|
| Closure (ss. 264.143 and 265.143)            | \$ _____ |
| Post-Closure Care (ss. 264.145 and 265.145)  | \$ _____ |
| Liability Coverage (ss. 264.147 and 265.147) | \$ _____ |
| Corrective Action (s. 264.101 (b))           | \$ _____ |
| Plugging and Abandonment (s. 144.63)         | \$ _____ |
| Closure                                      | \$ _____ |
| Post-Closure Care                            | \$ _____ |
| Liability Coverage                           | \$ _____ |
| Corrective Action                            | \$ _____ |
| Plugging and Abandonment                     | \$ _____ |
| Total  | \$ _____ |

This [insert: "owner or operator." or "guarantor"] has not received an adverse opinion, a disclaimer of opinion, or a "going concern" qualification from an independent auditor on his financial statements for the latest completed fiscal year.

[Fill in the information for Alternative I if the criteria of s. ILHR 10.82 (2) are being used to demonstrate compliance with the financial test requirements. Fill in the information for Alternative II if the criteria of s. ILHR 10.82 (3) are being used to demonstrate compliance with the financial test requirements.]



Alternative I

1. Amount of annual UST aggregate coverage being assured by a financial test, or guarantee, or both . . . . . \$ \_\_\_\_\_
  2. Amount of corrective action, closure and post-closure care costs, liability coverage, and plugging and abandonment costs covered by a financial test, or guarantee, or both. . . . . \$ \_\_\_\_\_
  3. Sum of lines 1 and 2 . . . . . \$ \_\_\_\_\_
  4. Total tangible assets . . . . . \$ \_\_\_\_\_
  5. Total liabilities [if any of the amount reported on line 3 is included in total liabilities, you may deduct that amount from this line and add that amount to line 6] . . . . . \$ \_\_\_\_\_
  6. Tangible net worth [subtract line 5 from line 4] . . . . . \$ \_\_\_\_\_
- |  | Yes   | No    |
|--|-------|-------|
| 7. Is line 6 at least \$10 million? . . . . .  | _____ | _____ |
| 8. Is line 6 at least 10 times line 3? . . . . .   | _____ | _____ |
| 9. Have financial statements for the latest fiscal year been filed with the Securities and Exchange Commission? . . . . .  | _____ | _____ |
| 10. Have financial statements for the latest fiscal year been filed with the Energy Information Administration? . . . . .  | _____ | _____ |
| 11. Have financial statements for the latest fiscal year been filed with the Rural Electrification Administration? . . . . .   | _____ | _____ |
| 12. Has financial information been provided to Dun and Bradstreet, and has Dun and Bradstreet provided a financial strength rating of 4A or 5A? [Answer "Yes" only if both criteria have been met] . . . . . | _____ | _____ |

Alternative II

- 1. Amount of annual UST aggregate coverage being assured by a test, or guarantee, or both . . . . . \$ \_\_\_\_\_
  - 2. Amount of corrective action, closure and post-closure care costs, liability coverage, and plugging and abandonment costs covered by a financial test, or guarantee, or both. . . . . \$ \_\_\_\_\_
  - 3. Sum of lines 1 and 2 . . . . . \$ \_\_\_\_\_
  - 4. Total tangible assets . . . . . \$ \_\_\_\_\_
  - 5. Total liabilities [if any of the amount reported on line 3 is included in total liabilities, you may deduct that amount from this line and add that amount to line 6] . . . . . \$ \_\_\_\_\_
  - 6. Tangible net worth [subtract line 5 from line 4] . . . . . \$ \_\_\_\_\_
  - 7. Total assets in the U.S. [required only if less than 90 percent of assets are located in the U.S.] . . . . . \$ \_\_\_\_\_
- |  |     |    |
|--|-----|----|
|  | Yes | No |
|--|-----|----|
- 8. Is line 6 at least \$10 million? . . . . . \_\_\_\_\_
  - 9. Is line 6 at least 6 times line 3? . . . . . \_\_\_\_\_
  - 10. Are at least 90 percent of assets located in the U.S.? [If "No," complete line 11] . . . . . \_\_\_\_\_
  - 11. Is line 7 at least 6 times line 3? [Fill in either lines 12-15 or lines 16-18:] . . . . . \_\_\_\_\_
  - 12. Current assets . . . . . \$ \_\_\_\_\_
  - 13. Current liabilities . . . . . \$ \_\_\_\_\_
  - 14. Net working capital [subtract line 13 from line 12]. . . . . \$ \_\_\_\_\_
  - 15. Is line 14 at least 6 times line 3? . . . . . \_\_\_\_\_
  - 16. Current bond rating of most recent bond issue . . . . . \_\_\_\_\_
  - 17. Name of rating service . . . . . \_\_\_\_\_
  - 18. Date of maturity of bond . . . . . \_\_\_\_\_
  - 19. Have financial statements for the latest fiscal year been filed with the US Securities and Exchange Commission, the Energy Information Administration, or the Rural Electrification Administration? . . . . . \_\_\_\_\_

[If "No," please attach a report from an independent certified public accountant certifying that there are no material differences between the data as reported in lines 4-18 above and the financial statements for the latest fiscal year.]

[For both Alternative I and Alternative II, complete the certification with this statement.]

I hereby certify that the wording of this letter is identical to the wording specified in s. ILHR 10.82 (4) as such regulations were constituted on the date shown immediately below.

[Signature]

[Name]

[Title]

[Date]

(5) If an owner or operator using the test to provide financial assurance finds that he or she no longer meets the requirements of the financial test based on the year-end financial statements, the owner or operator shall obtain alternative coverage within 150 days of the end of the year for which financial statements have been prepared.

(6) The department may require reports of financial condition at any time from the owner or operator, or guarantor, or both. If the department finds, on the basis of such reports or other information, that the owner or operator, or guarantor, or both, no longer meet the financial test requirements of subs. (2) or (3) and (4), the owner or operator shall obtain alternate coverage within 30 days after notification of such a finding.

(7) If the owner or operator fails to obtain alternate assurance within 150 days of finding that he or she no longer meets the requirements of the financial test based on the year-end financial statements, or within 30 days of notification by the department that he or she no longer meets the requirements of the financial test, the owner or operator shall notify the department of such failure within 10 days.

ILHR 10.822 GUARANTEE. (1) An owner or operator may satisfy the requirements of s. ILHR 10.816 by obtaining a guarantee that conforms to the requirements of this section. The guarantor shall be:

(a) A firm that:

1. Possesses a controlling interest in the owner or operator;
2. Possesses a controlling interest in a firm described under subd. 1; or
3. Is controlled through stock ownership by a common parent firm that possesses a controlling interest in the owner or operator; or

(b) A firm engaged in a substantial business relationship with the owner or operator and issuing the guarantee as an act incident to that business relationship.

(2) Within 120 days of the close of each financial reporting year, the guarantor shall demonstrate that it meets the financial test criteria of s. ILHR 10.82 based on year-end financial statements for the latest completed

financial reporting year by completing the letter from the chief financial officer described in s. ILHR 10.82 (4) and shall deliver the letter to the owner or operator. If the guarantor fails to meet the requirements of the financial test at the end of any financial reporting year, within 120 days of the end of that financial reporting year the guarantor shall send by certified mail, before cancellation or nonrenewal of the guarantee, notice to the owner or operator. If the department notifies the guarantor that he or she no longer meets the requirements of the financial test of s. ILHR 10.82 (2) or (3), the guarantor shall notify the owner or operator within 10 days of receiving such notification from the department. In both cases, the guarantee will terminate no less than 120 days after the date the owner or operator receives the notification, as evidenced by the return receipt. The owner or operator shall obtain alternative coverage as specified in s. ILHR 10.85 (3).

(3) The guarantee shall be worded as follows, except that instructions in brackets are to be replaced with the relevant information and the brackets deleted:

### **Guarantee**

Guarantee made this [date] by [name of guaranteeing entity], a business entity organized under the laws of the state of Wisconsin, herein referred to as guarantor, to the department and to any and all third parties, and obligees, on behalf of [owner or operator] of [business address].

### **Recitals.**

(1) Guarantor meets or exceeds the financial test criteria of s. ILHR 10.82 (2) or (3) and (4) and agrees to comply with the requirements for guarantors as specified in s. ILHR 10.822 (2).

(2) [Owner or operator] owns or operates the following underground storage tanks covered by this guarantee: [List the number of tanks at each facility and the names and addresses of the facilities where the tanks are located. If more than one instrument is used to assure different tanks at any one facility, for each tank covered by this instrument, list the tank identification number provided in the notification submitted pursuant to s. ILHR 10.13 or 10.14, and the name and address of the facility.] This guarantee satisfies ch. ILHR 10, Subch. 8 requirements for assuring funding for [insert: "compensating third parties for bodily injury and property damage caused by" either "sudden accidental releases" or "nonsudden accidental releases" or "accidental releases"; or "taking corrective action"; or both. If coverage is different for different tanks or locations, indicate the type of coverage applicable to each tank or location] arising from operating the above-identified underground storage tanks in the amount of [insert dollar amount] per occurrence and [insert dollar amount] annual aggregate.

(3) [Insert appropriate phrase: "On behalf of our subsidiary" (if guarantor is corporate parent of the owner or operator); "On behalf of our affiliate" (if guarantor is a related firm of the owner or operator); or "Incident to our business relationship with" (if guarantor is providing the guarantee as an incident to a substantial business relationship with owner or operator)] [owner or operator], guarantor guarantees to the department and to any and all third parties that:

In the event that [owner or operator] fails to provide alternative coverage within 60 days after receipt of a notice of cancellation of this guarantee and the department has determined or suspects that a release has occurred at an underground storage tank covered by this guarantee, the guarantor, upon instructions from the department, shall fund a standby trust fund in accordance with the provisions of s. ILHR 10.846, in an amount not to exceed the coverage limits specified above.

In the event that the department determines that [owner or operator] has failed to perform corrective action for releases arising out of the operation of the above-identified tanks in accordance with ch. ILHR 10, subch. 6, part 6, the guarantor upon written instructions from the department shall fund a standby trust in accordance with the provisions of s. ILHR 10.846, in an amount not to exceed the coverage limits specified above.

If [owner or operator] fails to satisfy a judgment or award based on a determination of liability for bodily injury or property damage to third parties caused by ["sudden" or "nonsudden" or both] accidental releases arising from the operation of the above-identified tanks, or fails to pay an amount agreed to in settlement of a claim arising from or alleged to arise from such injury or damage, the guarantor, upon written instructions from the department, shall fund a standby trust in accordance with the provisions of s. ILHR 10.846 to satisfy such judgments, awards, or settlement agreements up to the limits of coverage specified above.

(4) Guarantor agrees that if, at the end of any fiscal year before cancellation of this guarantee, the guarantor fails to meet the financial test criteria of s. ILHR 10.82 (2) or (3) and (4), guarantor shall send within 120 days of such failure, by certified mail, notice to [owner or operator]. The guarantee will terminate 120 days from the date of receipt of the notice by [owner or operator], as evidenced by the return receipt.

(5) Guarantor agrees to notify [owner or operator] by certified mail of a voluntary or involuntary proceeding under Title 11, U.S. Code naming guarantor as debtor, within 10 days after commencement of the proceeding.

(6) Guarantor agrees to remain bound under this guarantee notwithstanding any modification or alteration of any obligation of [owner or operator] pursuant to ch. ILHR 10.

(7) Guarantor agrees to remain bound under this guarantee for so long as [owner or operator] must comply with the applicable financial responsibility requirements of ch. ILHR 10, Subch. 8 for the above-identified tanks, except that guarantor may cancel this guarantee by sending notice by certified mail to [owner or operator], such cancellation to become effective no earlier than 120 days after receipt of such notice by [owner or operator], as evidenced by the return receipt.

(8) The guarantor's obligation does not apply to any of the following:

(a) Any obligation of [insert owner or operator] under a workers' compensation, disability benefits, or unemployment compensation law or other similar law;

(b) Bodily injury to an employee of [insert owner or operator] arising from, and in the course of, employment by [insert owner or operator];

(c) Bodily injury or property damage arising from the ownership, maintenance, use, or entrustment to others of any aircraft, motor vehicle, or watercraft;

(d) Property damage to any property owned, rented, loaded to, in the care, custody, or control of, or occupied by [insert owner or operator] that is not the direct result of a release from a petroleum underground storage tank;

(e) Bodily damage or property damage for which [insert owner or operator] is obligated to pay damages by reason of the assumption of liability in a contract or agreement other than a contract or agreement entered into to meet the requirements of s. ILHR 10.816.

(9) Guarantor expressly waives notice of acceptance of this guarantee by the department, by any or all third parties, or by [owner or operator].

I hereby certify that the wording of this guarantee is identical to the wording specified in s. ILHR 10.822 (3) as such regulations were constituted on the effective date shown immediately below.

Effective date: \_\_\_\_\_

[Name of guarantor]

[Authorized signature for guarantor]

[Name of person signing]

[Title of person signing]

Signature of witness or notary: \_\_\_\_\_

(10) An owner or operator who uses a guarantee to satisfy the requirements of s. ILHR 10.816 shall establish a standby trust fund when the guarantee is obtained. Under the terms of the guarantee, all amounts paid by the guarantor under the guarantee will be deposited directly into the standby trust fund in accordance with instructions from the department under s. ILHR 10.846. This standby trust fund shall meet the requirements specified in s. ILHR 10.836.

ILHR 10.824 INSURANCE AND RISK RETENTION GROUP COVERAGE. (1) An owner or operator may satisfy the requirements of s. ILHR 10.816 by obtaining liability insurance that conforms to the requirements of this section from a qualified insurer or risk retention group. Such insurance may be in the form of a separate insurance policy or an endorsement to an existing insurance policy.

(2) "Termination" under sub. (3) means only those changes that would result in a gap in coverage as where the insured has not obtained required coverage or has obtained required coverage with a different retroactive date than the retroactive date of the original policy.

(3) Each insurance policy shall be amended by an endorsement worded as specified in par. (a), or evidenced by a certificate of insurance worded as specified in par. (b), except that instructions in brackets shall be replaced with the relevant information and the brackets deleted:

(a) Endorsement.

Name: [name of each covered location]

Address: [address of each covered location]

Policy Number: \_\_\_\_\_

Period of Coverage: [current policy period]

Name of [Insurer or Risk Retention Group]:

Address of [Insurer or Risk Retention Group]:

Name of Insured: \_\_\_\_\_

Address of Insured: \_\_\_\_\_

Endorsement:

1. This endorsement certifies that the policy to which the endorsement is attached provides liability insurance covering the following underground storage tanks:

[List the number of tanks at each facility and the names and addresses of the facilities where the tanks are located. If more than one instrument is used to assure different tanks at any one facility, for each tank covered by this instrument, list the tank identification number provided in the notification submitted pursuant to s. ILHR 10.13 or 10.14, and the name and address of the facility.]

for [insert: "compensating third parties for bodily injury and property damage caused by" either "sudden accidental releases" or "nonsudden accidental releases" or "accidental releases"; or "taking corrective action"; or both, in accordance with and subject to the limits of liability, exclusions, conditions and other terms of this policy. If coverage is different for different tanks or locations, indicate the type of coverage applicable to each tank or location] arising from operating the underground storage tanks identified above.

The limits of liability are [insert the dollar amount of the "each occurrence" and "annual aggregate" limits of the Insurer's or Group's liability; if the amount of coverage is different for different types of coverage or for different underground storage tanks or locations, indicate the amount of coverage for each type of coverage or for each underground storage tank or location], exclusive of legal defense costs which are subject to a separate limit under the policy. This coverage is provided under [policy number]. The effective date of said policy is [date].

2. The insurance afforded with respect to such occurrences is subject to all of the terms and conditions of the policy; provided, however, that any provisions inconsistent with subsections a. through e. of this Paragraph 2 are hereby amended to conform with subsections a. through e.

a. Bankruptcy or insolvency of the insured shall not relieve the ["Insurer" or "Group"] of its obligations under the policy to which this endorsement is attached.

b. The ["Insurer" or "Group"] is liable for the payment of amounts within any deductible applicable to the policy to the provider of corrective action or a damaged third-party, with a right of reimbursement by the insured for any such payment made by the ["Insurer" or "Group"]. This provision does not apply with respect to that amount of any deductible for which coverage is demonstrated under another mechanism or combination of mechanisms as specified in ss. ILHR 10.82 to 10.834.

c. Whenever requested by the department, the ["Insurer" or "Group"] agrees to furnish to the department a signed duplicate original of the policy and all endorsements.

d. Cancellation or any other termination of the insurance by the ["Insurer" or "Group"], except for nonpayment of premium or misrepresentation by the insured, will be effective only upon written notice and only after the expiration of 60 days after a copy of such written notice is received by the insured. Cancellation for nonpayment or misrepresentation by the insured will be effective only upon written notice and only after expiration of a minimum of 10 days after a copy of such notice is received by the insured.

[Insert for claims-made policies:

e. The insurance covers claims otherwise covered by the policy that are reported to the ["Insurer" or "Group"] within six months of the effective date of cancellation or nonrenewal of the policy except where the new or renewed policy has the same retroactive date or a retroactive date earlier than that of the prior policy, and which arise out of any covered occurrence that commenced after the policy retroactive date, if applicable, and prior to such policy renewal or termination date. Claims reported during such extended reporting period are subject to the terms, conditions, limits, including limits of liability, and exclusions of the policy.]

I hereby certify that the wording of this instrument is identical to the wording in s. ILHR 10.824 (2)(a) and that the ["Insurer" or "Group"] is ["licensed to transact the business of insurance or eligible to provide insurance as an excess or surplus lines insurer in one or more states"].



[Signature of authorized representative of Insurer or Risk Retention Group]  
[Name of person signing]  
[Title of person signing], Authorized Representative of [name of Insurer or Risk Retention Group]  
[Address of Representative]

(b) Certificate of Insurance.

Name: [name of each covered location]

\_\_\_\_\_

Address: [address of each covered location]

\_\_\_\_\_

Policy Number: \_\_\_\_\_

Endorsement (if applicable): \_\_\_\_\_

Period of Coverage: [current policy period]

\_\_\_\_\_

Name of [Insurer or Risk Retention Group]:

\_\_\_\_\_

Address of [Insurer or Risk Retention Group]:

\_\_\_\_\_

Name of Insured: \_\_\_\_\_

Address of Insured: \_\_\_\_\_

\_\_\_\_\_

\_\_\_\_\_

Certification:

1. [Name of Insurer or Risk Retention Group], [the "Insurer" or "Group"], as identified above, hereby certifies that it has issued liability insurance covering the following underground storage tanks:

[List the number of tanks at each facility and the names and addresses of the facilities where the tanks are located. If more than one instrument is used to assure different tanks at any one facility, for each tank covered by this instrument, list the tank identification number provided in the notification submitted pursuant to s. ILHR 10.13 or 10.14, and the name and address of the facility.]

for [insert: "compensating third parties for bodily injury and property damage caused by" either "sudden accidental releases" or "nonsudden accidental releases" or "accidental releases"; or "taking corrective action"; or both in accordance with and subject to the limits of liability, exclusions, conditions, and other terms of the policy. If coverage is different for

different tanks or locations, indicate the type of coverage applicable to each tank or location] arising from operating the underground storage tanks identified above.

The limits of liability are [insert the dollar amount of the "each occurrence" and "annual aggregate" limits of the Insurer's or Group's liability; if the amount of coverage is different for different types of coverage or for different underground storage tanks or locations, indicate the amount of coverage for each type of coverage or for each underground storage tank or location], exclusive of legal defense costs, which are subject to a separate limit under the policy. This coverage is provided under [policy number]. The effective date of said policy is [date].

2. The ["Insurer" or "Group"] further certifies the following with respect to the insurance described in Paragraph 1:

a. Bankruptcy or insolvency of the insured shall not relieve the ["Insurer" or "Group"] of its obligations under the policy to which this certificate applies.

b. The ["Insurer" or "Group"] is liable for the payment of amounts within any deductible applicable to the policy to the provider of corrective action or a damaged third-party, with a right of reimbursement by the insured for any such payment made by the ["Insurer" or "Group"]. This provision does not apply with respect to that amount of any deductible for which coverage is demonstrated under another mechanism or combination of mechanisms as specified in s. ILHR 10.82 to 10.834.

c. Whenever requested by the department, the ["Insurer" or "Group"] agrees to furnish to the department a signed duplicate original of the policy and all endorsements.

d. Cancellation or any other termination of the insurance by the ["Insurer" or "Group"] except for nonpayment of premium or misrepresentation by the insured] will be effective only upon written notice and only after the expiration of 60 days after a copy of such written notice is received by the insured. Cancellation for nonpayment of premium or misrepresentation by the insured will be effective only upon written notice and only after expiration of a minimum of 10 days after a copy of such written notice is received by the insured.

[Insert for claims-made policies:

e. The insurance covers claims otherwise covered by the policy that are reported to the ["Insurer" or "Group"] within six months of the effective date of cancellation or nonrenewal of the policy except where the new or renewed policy has the same retroactive date or a retroactive date earlier than that of the prior policy, and which arise out of any covered occurrence that commenced after the policy retroactive date, if applicable, and prior to such policy renewal or termination date. Claims reported during such extended reporting period are subject to the terms, conditions, limits, including limits of liability, and exclusions of the policy.]

I hereby certify that the wording of this instrument is identical to the wording in s. ILHR 10.824 (2) (b) and that the ["Insurer" or "Group"] is ["licensed to transact the business of insurance, or eligible to provide insurance as an excess or surplus lines insurer, in one or more states"].

[Signature of authorized representative of Insurer]  
[Type name]  
[Title], Authorized Representative of [name of Insurer or Risk Retention Group]  
[Address of Representative]

(4) Each insurance policy shall be issued by an insurer or a risk retention group that is licensed to transact the business of insurance or eligible to provide insurance as an excess or surplus lines insurer in one or more states.

ILHR 10.826 SURETY BOND. (1) An owner or operator may satisfy the requirements of s. ILHR 10.816 by obtaining a surety bond that conforms to the requirements of this section. The surety company issuing the bond shall be among those listed as acceptable sureties on federal bonds in the latest Circular 570 of the U.S. Department of the Treasury.

(2) The surety bond shall be worded as follows, except that instructions in brackets shall be replaced with the relevant information and the brackets deleted:

**Performance Bond**

Date bond executed: \_\_\_\_\_  
Period of coverage: \_\_\_\_\_  
Principal: [legal name and business address of owner or operator]

\_\_\_\_\_  
Type of organization: [insert "individual," "joint venture," "partnership," or "corporation"]

\_\_\_\_\_  
State of incorporation [if applicable]:

\_\_\_\_\_  
Sureties: [names and business addresses]

Scope of Coverage: [List the number of tanks at each facility and the names and addresses of the facilities where the tanks are located. If more than one instrument is used to assure different tanks at any one facility, for each tank covered by this instrument, list the tank identification number provided in the notification submitted pursuant to s. ILHR 10.13 or 10.14, and the name and address of the facility. List the coverage guaranteed by the bond: "compensating third parties for bodily injury and property damage caused by" either "sudden accidental releases" or "nonsudden accidental releases" or "accidental releases" "arising from operating the underground storage tank", or "taking corrective action", or both].

Penal sums of bond:  
Per occurrence \$ \_\_\_\_\_  
Annual aggregate \$ \_\_\_\_\_  
Surety's bond number: \_\_\_\_\_

Know All Persons by These Presents, that we, the Principal and Sureties, hereto are firmly bound to the Department of Industry, Labor and Human Relations, in the above penal sums for the payment of which we bind ourselves, our heirs, executors, administrators, successors, and assigns jointly and severally; provided that, where the Sureties are corporations acting as co-sureties, we, the Sureties, bind ourselves in such sums jointly and severally only for the purpose of allowing a joint action or actions against any or all of us, and for all other purposes each Surety binds itself, jointly and severally with the Principal, for the payment of such sums only as is set forth opposite the name of such Surety, but if no limit of liability is indicated, the limit of liability shall be the full amount of the penal sums.

Whereas said Principal is required under Subtitle I of the resource Conservation and Recovery Act (RCRA), as amended, to provide financial assurance for [insert: "compensating third parties for bodily injury and property damage caused by" either "sudden accidental releases" or "nonsudden accidental releases" or "accidental releases", or "taking corrective action", or both. If coverage is different for different tanks or locations, indicate the type of coverage applicable to each tank or location] arising from operating the underground storage tanks identified above, and

Whereas said Principal shall establish a standby trust fund as is required when a surety bond is used to provide such financial assurance;

Now, therefore, the conditions of the obligation are such that if the Principal shall faithfully ["compensate injured third parties for bodily injury and property damage caused by" either "sudden" or "nonsudden" or "sudden and nonsudden" accidental releases arising from operating the tanks identified above; or "take corrective action, in accordance with s. ILHR 10, subch. 6, part 6"; or both] or if the Principal shall provide alternate financial assurance, as specified in ch. ILHR 10, subch. 8, within 120 days after the date the notice of cancellation is received by the Principal from the Sureties, then this obligation shall be null and void; otherwise it is to remain in full force and effect.

Such obligation does not apply to any of the following:

(a) Any obligation of [insert owner or operator] under a workers' compensation, disability benefits, or unemployment compensation law or other similar law;

(b) Bodily injury to an employee of [insert owner or operator] arising from, and in the course of, employment by [insert owner or operator];

(c) Bodily injury or property damage arising from the ownership, maintenance, use, or entrustment to others of any aircraft, motor vehicle, or watercraft;

(d) Property damage to any property owned, rented, loaned to, in the care, custody, or control of, or occupied by [insert owner or operator] that is not the direct result of a release from a petroleum underground storage tank;

(e) Bodily injury or property damage for which [insert owner or operator] is obligated to pay damages by reason of the assumption of liability in a contract or agreement other than a contract or agreement entered into to meet the requirements of s. ILHR 10.816.

The Surety(ies) shall become liable on this bond obligation only when the Principal has failed to fulfill the conditions described above.

Upon notification by the department that the Principal has failed to ["take corrective action, in accordance with s. ILHR 10, subch. 6, part 6" or "compensate injured third parties" or both] as guaranteed by this bond, the Sureties shall either perform ["corrective action in accordance with ch. ILHR 10" or "third-party liability compensation" or both] or place funds in an amount up to the annual aggregate penal sum into the standby trust fund as directed by the Regional Administrator or the department under s. ILHR 10.846.

Upon notification by the department that the Principal has failed to provide alternate financial assurance within 60 days after the date the notice of cancellation is received by the Principal from the Sureties and that the department has determined or suspects that a release has occurred, the Sureties shall place funds in an amount not exceeding the annual aggregate penal sum into the standby trust fund as directed by the department under s. ILHR 10.846.

The Sureties hereby waive notification of amendments to applicable laws, statutes, rules, and regulations and agrees that no such amendment shall in any way alleviate their obligation on this bond.

The liability of the Sureties shall not be discharged by any payment or succession of payments hereunder, unless and until such payment or payments shall amount in the annual aggregate to the penal sum shown on the face of the bond, but in no event shall the obligation of the Surety(ies) hereunder exceed the amount of said annual aggregate penal sum.

The Sureties may cancel the bond by sending notice of cancellation by certified mail to the Principal, provided, however, that cancellation shall not occur during the 120 days beginning on the date of receipt of the notice of cancellation of the Principal, as evidenced by the return receipt.

The Principal may terminate this bond by sending written notice to the Sureties.

In Witness Thereof, the Principal and Sureties have executed this Bond and have affixed their seals on the date set forth above.

The persons whose signatures appear below hereby certify that they are authorized to execute this surety bond on behalf of the Principal and Sureties and that the wording of this surety bond is identical to the wording specified in s. ILHR 10.826 (2) as such regulations were constituted on the date this bond was executed.

Principal

[Signatures]  
[Names]  
[Titles]  
[Corporate seal]

Corporate Sureties

[Name and address]  
[State of Incorporation: \_\_\_\_\_]  
[Liability limit: \$ \_\_\_\_\_]  
[Signatures]  
[Names and titles]  
[Corporate seal]

[For every co-surety, provide signatures, corporate seal, and other information in the same manner as for Surety above.]

Bond premium: \$ \_\_\_\_\_

(3) Under the terms of the bond, the surety shall be liable on the bond obligation when the owner or operator fails to perform as guaranteed by the bond. In all cases, the surety's liability is limited to the per-occurrence and annual aggregate penal sums.

(4) The owner or operator who uses a surety bond to satisfy the requirements of s. ILHR 10.816 shall establish a standby trust fund when the surety bond is acquired. Under the terms of the bond, all amounts paid by the surety under the bond will be deposited directly into the standby trust fund in accordance with instructions from the department under s. ILHR 10.846. This standby trust fund shall meet the requirements specified in s. ILHR 10.836.

ILHR 10.828 LETTER OF CREDIT. (1) An owner or operator may satisfy the requirements of s. ILHR 10.816 by obtaining an irrevocable standby letter of credit that conforms to the requirements of this section. The issuing institution shall be authorized to issue letters of credit in each state where the letters are used and the institution's letter-of-credit operations are regulated and examined by a federal or state agency.

(2) The letter of credit shall be worded as follows, except that instructions in brackets are to be replaced with the relevant information and the brackets deleted:

## Irrevocable Standby Letter of Credit

[Name and address of issuing institution]  
The Department of Industry, Labor and Human Relations  
P. O. Box 7969, Madison, WI 53707

Dear Sir or Madam: We hereby establish our Irrevocable Standby Letter of Credit No. \_\_\_\_\_ in your favor, at the request and for the account of [owner or operator name] of [address] up to the aggregate amount of [in words] U.S. dollars (\$[insert dollar amount]), available upon presentation of:

(1) your sight draft, bearing reference to this letter of credit, No. \_\_\_\_\_, and

(2) your signed statement reading as follows: "I certify that the amount of the draft is payable pursuant to regulations issued under authority of Subtitle I of the Resource Conservation and Recovery Act of 1976, as amended."

This letter of credit may be drawn on to cover [insert: "compensating third parties for bodily injury and property damage caused by" either "sudden accidental releases" or "nonsudden accidental releases" or "accidental releases", or "taking corrective action", or both] arising from operating the underground storage tanks identified below in the amount of [in words] (\$[insert dollar amount]) per occurrence and [in words] (\$[insert dollar amount]) annual aggregate:

[List the number of tanks at each facility and the names and addresses of the facilities where the tanks are located. If more than one instrument is used to assure different tanks at any one facility, for each tank covered by this instrument, list the tank identification number provided in the notification submitted pursuant to s. ILHR 10.13 or 10.14, and the name and address of the facility.]

The letter of credit may not be drawn on to cover any of the following:

(a) Any obligation of [insert owner or operator] under a worker's compensation, disability benefits, or unemployment compensation law or other similar law;

(b) Bodily injury to an employee of [insert owner or operator] arising from, and in the course of, employment by [insert owner or operator];

(c) Bodily injury or property damage arising from the ownership, maintenance, use, or entrustment to others of any aircraft, motor vehicle, or watercraft;

(d) Property damage to any property owned, rented, loaned to, in the care, custody, or control of, or occupied by [insert owner or operator] that is not the direct result of a release from a petroleum underground storage tank;

(e) Bodily injury or property damage for which [insert owner or operator] is obligated to pay damages by reason of the assumption of liability in a contract or agreement other than a contract or agreement entered into to meet the requirements of s. ILHR 10.816.

This letter of credit is effective as of [date] and shall expire on [date], but such expiration date shall be automatically extended for a period of [at least the length of the original term] on [expiration date] and on each successive expiration date, unless, at least 120 days before the current expiration date, we notify [owner or operator] by certified mail that we have decided not to extend this letter of credit beyond the current expiration date. In the event that [owner or operator] is so notified, any unused portion of the credit shall be available upon presentation of your sight draft for 120 days after the date of receipt by [owner or operator], as shown on the signed return receipt.

Whenever this letter of credit is drawn on under and in compliance with the terms of this credit, we shall duly honor such draft upon presentation to us, and we shall deposit the amount of the draft directly into the standby trust fund of [owner or operator] in accordance with your instructions.

We certify that the wording of this letter of credit is identical to the wording specified in s. ILHR 10.828 (2) as such regulations were constituted on the date shown immediately below.

[Signatures and titles of officials of issuing institution]  
[Date]

This credit is subject to [insert "the most recent edition of the Uniform Customs and Practice for Documentary Credits, published by the International Chamber of Commerce," or "the Uniform Commercial Code"].

(3) An owner or operator who uses a letter of credit to satisfy the requirements of s. ILHR 10.816 shall also establish a standby trust fund when the letter of credit is acquired. Under the terms of the letter of credit, all amounts paid pursuant to a draft by the department will be deposited by the issuing institution directly into the standby trust fund in accordance with instructions from the department under s. ILHR 10.846. This standby trust fund shall meet the requirements specified in s. ILHR 10.836.

(4) The letter of credit shall be irrevocable with a term specified by the issuing institution. The letter of credit shall provide that credit be automatically renewed for the same term as the original term, unless, at least 120 days before the current expiration date, the issuing institution notifies the owner or operator by certified mail of its decision not to renew the letter of credit. Under the terms of the letter of credit, the 120 days will begin on the date the owner or operator receives the notice, as evidenced by the return receipt.

ILHR 10.834 TRUST FUND. (1) An owner or operator may satisfy the requirements of s. ILHR 10.816 by establishing a trust fund that conforms to the requirements of this section. The trustee shall be an entity that has the



authority to act as a trustee and whose trust operations are regulated and examined by a federal agency or an agency of the state in which the fund is established.

(2) The wording of the trust agreement shall be identical to the wording specified in s. ILHR 10.836 (2)(a), and shall be accompanied by a formal certification of acknowledgment as specified in s. ILHR 10.836 (2) (b).

(3) The trust fund, when established, shall be funded for the full required amount of coverage, or funded for part of the required amount of coverage and used in combination with other mechanisms that provide the remaining required coverage.

(4) If the value of the trust fund is greater than the required amount of coverage, the owner or operator may submit a written request to the department for release of the excess.

(5) If other financial assurance as specified in this subchapter is substituted for all or part of the trust fund, the owner or operator may submit a written request to the department for release of the excess.

(6) Within 60 days after receiving a request from the owner or operator for release of funds as specified in sub. (4) or (5), the department will instruct the trustee to release to the owner or operator such funds as the department specifies in writing.

ILHR 10.836 STANDBY TRUST FUND. (1) An owner or operator using any one of the mechanisms authorized by ss. ILHR 10.822, 10.826 or 10.828 shall establish a standby trust fund when the mechanism is acquired. The trustee of the standby trust fund shall be an entity that has the authority to act as a trustee and whose trust operations are regulated and examined by a federal agency or an agency of the state in which the fund is established.

(2)(a) The standby trust agreement or trust agreement shall be worded as follows, except that instructions in brackets are to be replaced with the relevant information and the brackets deleted:

#### Trust Agreement

Trust agreement, the "Agreement," entered into as of [date] by and between [name of the owner or operator], a [name of state] [insert "corporation," "partnership," "association," or "proprietorship"], the "Grantor," and [name of corporate trustee], [insert "Incorporated in the state of \_\_\_\_\_" or "a national bank"], the "Trustee."

Whereas, the United States Environmental Protection Agency, "EPA," an agency of the United States Government, has established certain regulations applicable to the Grantor, requiring that an owner or operator of an underground storage tank shall provide assurance that funds will be available when needed for corrective action and third-party compensation for bodily injury and property damage caused by sudden and nonsudden accidental releases arising from the operation of the underground storage tank. The attached

Schedule A lists the number of tanks at each facility and the names and addresses of the facilities where the tanks are located that are covered by the standby trust agreement.

[Whereas, the Grantor has elected to establish [insert either "a guarantee," "surety bond," or "letter of credit"] to provide all or part of such financial assurance for the underground storage tanks identified herein and is required to establish a standby trust fund able to accept payments from the instrument (This paragraph is only applicable to the standby trust agreement.);];

Whereas, the Grantor, acting through its duly authorized officers, has selected the Trustee to be the trustee under this agreement, and the Trustee is willing to act as trustee;

Now, therefore, the Grantor and the Trustee agree as follows:

#### Section 1. Definitions

As used in this Agreement:

(a) The term "Grantor" means the owner or operator who enters into this Agreement and any successors or assigns of the Grantor.

(b) The term "Trustee" means the Trustee who enters into this Agreement and any successor Trustee.

#### Section 2. Identification of the Financial Assurance Mechanism

This Agreement pertains to the [identify the financial assurance mechanism, either a guarantee, surety bond, or letter of credit, from which the standby trust fund is established to receive payments (This paragraph is only applicable to the standby trust agreement.)]

#### Section 3. Establishment of Fund

The Grantor and the Trustee hereby establish a trust fund, the "Fund," for the benefit of the department. The Grantor and the Trustee intend that no third party have access to the Fund except as herein provided. [The Fund is established initially as a standby to receive payments and shall not consist of any property.] Payments made by the provider of financial assurance pursuant to the department's instruction are transferred to the Trustee and are referred to as the Fund, together with all earnings and profits thereon, less any payments or distributions made by the Trustee pursuant to this Agreement. The Fund shall be held by the Trustee, IN TRUST, as hereinafter provided. The Trustee shall not be responsible nor shall it undertake any responsibility for the amount or adequacy of, nor any duty to collect from the Grantor as provider of financial assurance, any payments necessary to discharge any liability of the Grantor established by the department.

Section 4. Payment for ["Corrective Action" or Third-Party Liability Claims," or both]

The Trustee shall make payments from the Fund as the department shall direct, in writing, to provide for the payment of the costs of [insert: "compensating third parties for bodily injury and property damage caused by" either "sudden accidental releases" or "nonsudden accidental releases" or "accidental releases"; or "taking corrective action"; or both] arising from operating the tanks covered by the financial assurance mechanism identified in this Agreement.

The Fund may not be drawn upon to cover any of the following:

- (a) Any obligation of [insert owner or operator] under a workers' compensation, disability benefits, or unemployment compensation law or other similar law;
- (b) Bodily injury to an employee of [insert owner or operator] arising from, and in the course of employment by [insert owner or operator];
- (c) Bodily injury or property damage arising from the ownership, maintenance, use, or entrustment to others of any aircraft, motor vehicle, or watercraft;
- (d) Property damage to any property owned, rented, loaned to, in the care, custody, or control of, or occupied by [insert owner or operator] that is not the direct result of a release from a petroleum underground storage tank;
- (e) Bodily injury or property damage for which [insert owner or operator] is obligated to pay damages by reason of the assumption of liability in a contract or agreement other than a contract or agreement entered into to meet the requirements of s. ILHR 10.816.

The Trustee shall reimburse the Grantor, or other persons as specified by the department, from the Fund for corrective action expenditures or third-party liability claims, or both, in such amounts as the department shall direct in writing. In addition, the Trustee shall refund to the Grantor such amounts as the department specifies in writing. Upon refund, such funds shall no longer constitute part of the fund as defined herein.

#### Section 5. Payments Comprising the Fund

Payments made to the Trustee for the Fund shall consist of cash and securities acceptable to the Trustee.

#### Section 6. Trustee Management

The Trustee shall invest and reinvest the principal and income of the Fund and keep the Fund invested as a single fund, without distinction between principal and income, in accordance with general investment policies and guidelines which the Grantor may communicate in writing to the Trustee from time to time, subject, however, to the provisions of this Section. In investing, reinvesting, exchanging, selling, and managing the Fund, the Trustee shall discharge his duties with respect to the trust fund solely in the interest of the beneficiaries and with the care, skill, prudence, and

diligence under the circumstances then prevailing which persons of prudence, acting in a like capacity and familiar with such matters, would use in the conduct of an enterprise of a like character and with like aims; except that:

(i) Securities or other obligations of the Grantor, or any other owner or operator of the tanks, or any of their affiliates as defined in the Investment Company Act of 1940, as amended, 15 U.S.C. 80a-2(a), shall not be acquired or held, unless they are securities or other obligations of the federal or a state government;

(ii) The Trustee is authorized to invest the Fund in time or demand deposits of the Trustee, to the extent insured by an agency of the federal or state government; and

(iii) The Trustee is authorized to hold cash awaiting investment or distribution uninvested for a reasonable time and without liability for the payment of interest thereon.

#### Section 7. Commingling and Investment

The Trustee is expressly authorized in its discretion:

(a) To transfer from time to time any or all of the assets of the Fund to any common, commingled, or collective trust fund created by the Trustee in which the Fund is eligible to participate, subject to all of the provisions thereof, to be commingled with the assets of other trusts participating therein; and

(b) To purchase shares in any investment company registered under the Investment Company Act of 1940, 15 U.S.C. 80a-1 et seq., including one which may be created, managed, underwritten, or to which investment advice is rendered or the shares of which are sold by the Trustee. The Trustee may vote such shares in its discretion.

#### Section 8. Express Powers of Trustee

Without in any way limiting the powers and discretions conferred upon the Trustee by the other provisions of this Agreement or by law, the Trustee is expressly authorized and empowered:

(a) To sell, exchange, convey, transfer, or otherwise dispose of any property held by it, by public or private sale. No person dealing with the Trustee shall be bound to see to the application of the purchase money or to inquire into the validity or expediency of any such sale or other disposition;

(b) To make, execute, acknowledge, and deliver any and all documents of transfer and conveyance and any and all other instruments that may be necessary or appropriate to carry out the powers herein granted;

(c) To register any securities held in the fund in its own name or in the name of a nominee and to hold any security in bearer form or in book entry, or to combine certificates representing such securities with certificates of the same issue held by the Trustee in other fiduciary

capacities, or to deposit or arrange for the deposit of such securities in a qualified central depository even though, when so deposited, such securities may be merged and held in bulk in the name of the nominee of such depository with other securities deposited therein by another person, or to deposit or arrange for the deposit of any securities issued by the United States Government, or any agency or instrumentality thereof, with a Federal Reserve bank, but the books and records of the Trustee shall at all times show that all such securities are part of the Fund;

(d) To deposit any cash in the Fund in interest-bearing accounts maintained or savings certificates issued by the Trustee, in its separate corporate capacity, or in any other banking institution affiliated with the Trustee, to the extent insured by an agency of the federal or state government; and

(e) To compromise or otherwise adjust all claims in favor of or against the Fund.

#### Section 9. Taxes and Expenses

All taxes of any kind that may be assessed or levied against or in respect of the Fund and all brokerage commissions incurred by the Fund shall be paid from the Fund. All other expenses incurred by the Trustee in connection with the administration of this Trust, including fees for legal services rendered to the Trustee, the compensation of the Trustee to the extent not paid directly by the Grantor, and all other proper charges and disbursements of the Trustee shall be paid from the fund.

#### Section 10. Advice of Counsel

The Trustee may from time to time consult with counsel, who may be counsel to the Grantor, with respect to any questions arising as to the construction of this Agreement or any action to be taken hereunder. The Trustee shall be fully protected, to the extent permitted by law, in acting upon the advice of counsel.

#### Section 11. Trustee Compensation

The Trustee shall be entitled to reasonable compensation for its services as agreed upon in writing from time to time with the Grantor.

#### Section 12. Successor Trustee

The Trustee may resign or the Grantor may replace the Trustee, but such resignation or replacement shall not be effective until the Grantor has appointed a successor trustee and this successor accepts the appointment. The successor trustee shall have the same powers and duties as those conferred upon the Trustee hereunder. Upon the successor trustee's acceptance of the appointment, the Trustee shall assign, transfer, and pay over to the successor trustee the funds and properties then constituting the Fund. If for any reason the Grantor cannot or does not act in the event of the resignation of the Trustee, the Trustee may apply to a court of competent jurisdiction for the appointment of a successor trustee or for instructions. The successor

trustee shall specify the date on which it assumes administration of the trust in writing sent to the Grantor and the present Trustee by certified mail 10 days before such change becomes effective. Any expenses incurred by the Trustee as a result of any of the acts contemplated by this Section shall be paid as provided in Section 9.

#### Section 13. Instructions to the Trustee.

All orders, requests, and instructions by the Grantor to the Trustee shall be in writing, signed by such persons as are designated in the attached Schedule B or such other designees as the Grantor may designate by amendment to Schedule B. The Trustee shall be fully protected in acting without inquiry in accordance with the Grantor's orders, requests, and instructions. All orders, requests, and instructions by the department to the Trustee shall be in writing, signed by the department, and the Trustee shall act and shall be fully protected in acting in accordance with such orders, requests, and instructions. The Trustee shall have the right to assume, in the absence of written notice to the contrary, that no event constituting a change or a termination of the authority of any person to act on behalf of the Grantor or the department hereunder has occurred. The Trustee shall have no duty to act in the absence of such orders, requests, and instructions from the Grantor or the department, or both except as provided for herein.

#### Section 14. Amendment of Agreement

This Agreement may be amended by an instrument in writing executed by the Grantor and the Trustee, or by the trustee and the department if the Grantor ceases to exist.

#### Section 15. Irrevocability and Termination

Subject to the right of the parties to amend this Agreement as provided in Section 14, this Trust shall be irrevocable and shall continue until terminated at the written direction of the Grantor and the Trustee, or by the Trustee and the department, if the Grantor ceases to exist. Upon termination of the Trust, all remaining trust property, less final trust administration expenses, shall be delivered to the Grantor.

#### Section 16. Immunity and Indemnification

The Trustee shall not incur personal liability of any nature in connection with any act or omission, made in good faith, in the administration of this Trust, or in carrying out any directions by the Grantor or the department issued in accordance with this Agreement. The Trustee shall be indemnified and saved harmless by the Grantor, from and against any personal liability to which the Trustee may be subjected by reason of any act or conduct in its official capacity, including all expenses reasonably incurred in its defense in the event the Grantor fails to provide such defense.

#### Section 17. Choice of Law

This Agreement shall be administered, construed, and enforced according to the laws of the state of Wisconsin, or the Comptroller of the Currency in the case of National Association banks.

Section 18. Interpretation

As used in this Agreement, words in the singular include the plural and words in the plural include the singular. The descriptive headings for each section of this Agreement shall not affect the interpretation or the legal efficacy of this Agreement.

In Witness whereof the parties have caused this Agreement to be executed by their respective officers duly authorized and their corporate seals (if applicable) to be hereunto affixed and attested as of the date first above written. The parties below certify that the wording of this Agreement is identical to the wording specified in s. ILHR 10.836 (2) (a) as such regulations were constituted on the date written above.

[Signature of Grantor]  
[Name of the Grantor]  
[Title]

Attest:

[Signature of Trustee]  
[Name of the Trustee]  
[Title]  
[Seal]  
[Signature of Witness]  
[Name of the Witness]  
[Title]  
[Seal]

(b) The standby trust agreement, or trust agreement shall be accompanied by a formal certification of acknowledgment similar to the following. State requirements may differ on the proper content of this acknowledgment.

State of \_\_\_\_\_  
County of \_\_\_\_\_

On this [date], before me personally came [owner or operator] to me known, who, being by me duly sworn, did depose and say that she or he resides at [address], that she or he is [title] of [corporation], the corporation described in and which executed the above instrument; that she or he knows the seal of said corporation; that the seal affixed to such instrument is such corporate seal; that it was so affixed by order of the Board of Directors of said corporation; and that she or he signed her or his name thereto by like order.

[Signature of Notary Public]  
[Name of Notary Public]

(3) The department will instruct the trustee to refund the balance of the standby trust fund to the provider of financial assurance if the department determines that no additional corrective action costs or third-party liability claims will occur as a result of a release covered by the financial assurance mechanism for which the standby trust fund was established.

(4) An owner or operator may establish one trust fund as the depository mechanism for all funds assured in compliance with this rule.

ILHR 10.838 SUBSTITUTION OF FINANCIAL ASSURANCE MECHANISMS BY OWNER OR OPERATOR. (1) An owner or operator may substitute any alternate financial assurance mechanisms as specified in this subchapter, provided that at all times an effective financial assurance mechanism or combination of mechanisms is maintained that satisfies the requirements of s. ILHR 10.816.

(2) After obtaining alternate financial assurance as specified in this subchapter an owner or operator may cancel a financial assurance mechanism by providing notice to the provider of financial assurance.

ILHR 10.84 CANCELLATION OR NONRENEWAL BY A PROVIDER OF FINANCIAL ASSURANCE. (1) Except as otherwise provided, a provider of financial assurance may cancel or fail to renew an assurance mechanism by sending a notice of termination by certified mail to the owner or operator.

(a) Termination of a guarantee, a surety bond, or a letter of credit may not occur until 120 days after the date on which the owner or operator receives the notice of termination, as evidenced by the return receipt.

(b) Termination of insurance or risk retention group coverage or state-funded assurance, except for nonpayment or misrepresentation by the insured, may not occur until 60 days after the date on which the owner or operator received notice of termination, as evidenced by the return receipt. Termination for nonpayment of premium or misrepresentation by the insured may not occur until a minimum of 10 days after the date on which the owner or operator receives the notice of termination, as evidenced by the return receipt.

(2) If a provider of financial responsibility cancels or fails to renew for reasons other than incapacity of the provider as specified in s. ILHR 10.842, the owner or operator shall obtain alternate coverage as specified in this section within 60 days after receipt of the notice of termination. If the owner or operator fails to obtain alternate coverage within 60 days after receipt of the notice of termination, the owner or operator shall notify the department of such failure and submit:

(a) The name and address of the provider of financial assurance;

(b) The effective date of termination; and

(c) The evidence of the financial assistance mechanism subject to the termination maintained in accordance with s. ILHR 10.844 (2).

ILHR 10.842 REPORTING BY OWNER OR OPERATOR. (1) An owner or operator shall submit the appropriate forms listed in s. ILHR 10.844 (2) documenting current evidence of financial responsibility to the department:

(a) Within 30 days after the owner or operator identifies a release from an underground storage tank required to be reported under s. ILHR 10.64;



(b) If the owner or operator fails to obtain alternate coverage as required by this subchapter, within 30 days after the owner or operator receives notice of:

1. Commencement of a proceeding under Title 11, U.S. Code, naming a provider of financial assurance as a debtor;
2. Suspension or revocation of the authority of a provider of financial assurance to issue a financial assurance mechanism;
3. Failure of a guarantor to meet the requirements of the financial test;
4. Other incapacity of a provider of financial assurance; or

(c) As required by ss. ILHR 10.82 (7) and 10.84 (2).

(2) An owner or operator shall certify compliance with the financial responsibility requirements of this subchapter as specified in the new tank notification form when notifying the appropriate state or local agency of the installation of a new underground storage tank under s. ILHR 10.13 or 10.14.

(3) The department may require an owner or operator to submit evidence of financial assurance as described in s. ILHR 10.844 (2) or other information relevant to compliance with this subchapter at any time.

Note: The information requirements in this section have been approved by the Office of Management and Budget and assigned OMB control number 2050-0066.

ILHR 10.844 RECORDKEEPING. (1) Owners or operators shall maintain evidence of all financial assurance mechanisms used to demonstrate financial responsibility under this subchapter for an underground storage tank until released from the requirements of this subchapter under s. ILHR 10.848. An owner or operator shall maintain such evidence at the underground storage tank site or the owner's or operator's place of business. Records maintained off-site shall be made available upon request of the department.

(2) An owner or operator shall maintain the following types of evidence of financial responsibility:

(a) An owner or operator using an assurance mechanism specified in ss. ILHR 10.82 through 10.83 or 10.834 shall maintain a copy of the instrument.

(b) An owner or operator using a financial test or guarantee shall maintain a copy of the chief financial officer's letter based on year-end financial statements for the most recent completed financial reporting year. Such evidence shall be on file no later than 120 days after the close of the financial reporting year.

(c) An owner or operator using a guarantee, surety bond, or letter of credit shall maintain a copy of the signed standby trust fund agreement and copies of any amendments to the agreement.

(d) An owner or operator using an insurance policy or risk retention group coverage shall maintain a copy of the signed insurance policy or risk retention group coverage policy, with the endorsement or certificate of insurance and any amendments to the agreements.

(e) An owner or operator covered by a state fund or other state assurance shall maintain on file a copy of any evidence of coverage supplied by or required by the State under s. ILHR 10.832 (4).

(f) An owner or operator using an assurance mechanism specified in ss. ILHR 10.82 through 10.834 shall maintain an updated copy of a certification of financial responsibility worded as follows, except that instructions in brackets are to be replaced with the relevant information and the brackets deleted:

### **Certification of Financial Responsibility**

[Owner or operator] hereby certifies that it is in compliance with the requirements of ch. ILHR 10, subch. 8.

The financial assurance mechanisms used to demonstrate financial responsibility under ch. ILHR 10, subch. 8 are as follows:

[For each mechanism, list the type of mechanism, name of issuer, mechanism number (if applicable), amount of coverage, effective period of coverage and whether the mechanism covers: "compensating third parties for bodily injury and property damage caused by" either "sudden accidental releases" or "nonsudden accidental releases" or "accidental releases"; or "taking corrective action"; or both.]

[Signature of owner or operator]

[Name of owner or operator]

[Title]

[Date]

[Signature of witness or notary]

[Name of witness or notary]

[Date]

(g) The owner or operator shall update this certification whenever the financial assurance mechanisms used to demonstrate financial responsibility change.

Note: The information requirements in this section have been approved by the Office of Management and Budget and assigned OMB control number 2050-0066.

ILHR 10.846 DRAWING ON FINANCIAL ASSURANCE MECHANISMS. (1) The department shall require the guarantor, surety, or institution issuing a letter of credit to place the amount of funds stipulated by the department, up to the limit of funds provided by the financial assurance mechanism, into the standby trust if:

(a) 1. The owner or operator fails to establish alternate financial assurance within 60 days after receiving notice of cancellation of the guarantee, surety bond, letter of credit, or, as applicable, other financial assurance mechanism; and

2. The department determines or suspects that a release from an underground storage tank covered by the mechanism has occurred and so notifies the owner or operator or the owner or operator has notified the department pursuant to parts 5 or 6 of subch. 6 of a release from an underground storage tank covered by the mechanism; or

(b) The conditions of sub. (2) (a) or (2) (b) 1. or 2. are satisfied.

(2) The department may draw on a standby trust fund when:

(a) The department makes a final determination that a release has occurred and immediate or long-term corrective action for the release is needed, and the owner or operator, after appropriate notice and opportunity to comply, has not conducted corrective action as required under subch. 6, part 6; or

(b) The department has received one of the following:

1. Certification from the owner or operator and the third-party liability claimants and from attorneys representing the owner or operator and the third-party liability claimants that a third-party liability claim should be paid. The certification shall be worded as follows, except that instructions in brackets are to be replaced with the relevant information and the brackets deleted:

**Certification of Valid Claim**

The undersigned, as principals and as legal representatives of [insert owner or operator] and [insert name and address of third-party claimant], hereby certify that the claim of bodily injury or, property damage caused by an accidental release arising from operating [owner's or operator's] underground storage tank, or both, should be paid in the amount of \$[\_\_\_\_\_].

[Signatures]

Owner or Operator  
Attorney for Owner or Operator  
[Notary] Date

[Signatures]

Claimants  
Attorneys for Claimants  
[Notary] Date

2. A valid final court order establishing a judgment against the owner or operator for bodily injury or property damage caused by an accidental release from an underground storage tank covered by financial assurance under this subchapter and the department determines that the owner or operator has not satisfied the judgment.

(3) If the department determines that the amount of corrective action costs and third-party liability claims eligible for payment under sub. (2) may exceed the balance of the standby trust fund and the obligation of the provider of financial assurance, the first priority for payment shall be corrective action costs necessary to protect human health and the environment. The department shall pay third-party liability claims in the order in which the department receives certifications under sub. (2) (b) 1. and valid court orders under sub. (2) (b) 2.

ILHR 10.848 RELEASE FROM THE REQUIREMENTS. An owner or operator is no longer required to maintain financial responsibility under this subchapter for an underground storage tank after the tank has been properly closed or, if corrective action is required, after corrective action has been completed and the tank has been properly closed as required by subch. 6, part 7.

ILHR 10.85 BANKRUPTCY OR OTHER INCAPACITY OF OWNER OR OPERATOR OR PROVIDER OF FINANCIAL ASSURANCE. (1) Within 10 days after commencement of a proceeding under Title 11, U.S. Code, naming an owner or operator as debtor, the owner or operator shall notify the department by certified mail of such commencement and submit the appropriate forms listed in s. ILHR 10.844 (2) documenting current financial responsibility.

(2) Within 10 days after commencement of a proceeding under Title 11, U.S. Code, naming a guarantor providing financial assurance as debtor, such guarantor shall notify the owner or operator by certified mail of such commencement as required under the terms of the guarantee specified in s. ILHR 10.822.

(3) An owner or operator who obtains financial assurance by a mechanism other than the financial test of self-insurance will be deemed to be without the required financial assurance in the event of a bankruptcy or incapacity of its provider of financial assurance, or a suspension or revocation of the authority of the provider of financial assurance to issue a guarantee, insurance policy, risk retention group coverage policy, surety bond, letter of credit, or state-required mechanism. The owner or operator shall obtain alternate financial assurance as specified in this subchapter within 30 days after receiving notice of such an event. If the owner or operator does not obtain alternate coverage within 30 days after such notification, he or she shall notify the department.

(4) Within 30 days after receipt of notification that the state fund or other state assurance has become incapable of paying for assured corrective action or third-party compensation costs, the owner or operator shall obtain alternate financial assurance.

ILHR 10.852 REPLENISHMENT OF GUARANTEES, LETTERS OF CREDIT, OR SURETY BONDS. (1) If at any time after a standby trust is funded upon the instruction of the department with funds drawn from a guarantee, letter of credit, or surety bond, and the amount in the standby trust is reduced below the full amount of coverage required, the owner or operator shall by the anniversary date of the financial mechanism from which the funds were drawn:

(a) Replenish the value of financial assurance to equal the full amount of coverage required; or

(b) Acquire another financial assurance mechanism for the amount by which funds in the standby trust have been reduced.

(2) For purposes of this section, the full amount of coverage required is the amount of coverage to be provided by s. ILHR 10.816. If a combination of mechanisms was used to provide the assurance funds which were drawn upon, replenishment shall occur by the earliest anniversary date among the mechanisms.

SUBCHAPTER IX - QUALIFICATIONS, TESTING PROCEDURES  
AND DUTIES FOR CERTIFIED PERSONS

PART 1 - APPLICATION

ILHR 10.91 GENERAL. This subchapter applies to all persons who install, remove, clean, line, perform tightness testing on and inspect underground or aboveground storage tank systems, persons who perform site assessments and to companies that provide services which require certification under the scope of this chapter.

PART 2 - PROCEDURES FOR CERTIFICATION OR REGISTRATION

ILHR 10.912 ELIGIBILITY FOR CERTIFICATION. (1) GENERAL. Eligibility for certification shall be based upon receipt and approval of the application and fee after the successful completion of an approved examination.

(2) EXCEPTION. For one year after the effective date of this chapter, interim certifications may be obtained and used without a testing requirement.

ILHR 10.914 APPLICATION FOR CERTIFICATION OR RECERTIFICATION. (1) All applicants shall be at least 18 years of age.

(2) Application for certification and recertification shall be made to the department, together with the payment of the fees as specified in s. Ind. 69.125.

(a) Applications shall be made on forms provided by the department and may be obtained by writing to:

Certification Coordinator  
Safety and Buildings Division  
Department of Industry, Labor and Human Relations  
P.O. Box 7969  
Madison, Wisconsin 53707

(3) Upon receipt of the completed application form, the department shall review and evaluate the application and make all necessary notifications to the applicant within 15 days of the receipt of the application.

If it is determined that the applicant does not qualify for certification or recertification, the applicant shall be notified of the findings in writing and instructed of the appeals procedure provided under Part 4 of this Subchapter.

ILHR 10.916 EXAMINATION. (1) APPLICATION FOR EXAMINATION. All applications for examination shall be filed with the department prior to examination. The applicant shall be advised by the department of the date and place of the next scheduled examination within 30 business days of receipt of an application for examination.

(2) EXAM FORMAT. Exams shall be a written format unless an oral test or other alternative test is provided for special circumstances.

(3) TIME AND PLACE OF EXAMINATIONS. Scheduled examinations shall be offered at least annually. Specific details regarding time and place are available from the department upon request. The department shall schedule an examination within 9 months of the date of the last examination.

(4) SCOPE OF EXAMINATION. The examinations shall test the applicant's ability to either inspect, or install, or remove or perform tightness testing on storage tank systems or perform site assessments, including but not limited to:

(a) For installers, the standards for tank installation specified in s. ILHR 10.51;

(b) For removers and cleaners, the standards for tank system closure specified in ss. ILHR 10.36 and 10.732;

(c) For tightness testers, the standards for tightness testing specified in ss. ILHR 10.61 (3) and 10.615 (2). Tightness testers shall submit proof of department approval of the test method or methods they plan to use;

(d) For liners, the standards specified in ss. ILHR 10,345, 10.52 (2)(d) 1. and 2., and 10.734.

(e) For site assessment providers, site assessment procedures specified in s. ILHR 10.734 including procedures for the taking and handling of samples. Applicants for certification in this category shall submit a description of the sampling protocol they intend to use for department review as a part of their examination;

(f) For inspectors, all code requirements relating to groundwater protection. Applicants for certification in this category shall submit proof of completion of a department approved educational course or training program.

(g) For all applicants, skills such as general mathematics, reading of plans and specifications, materials and methods of storage tank system construction, fire safety and groundwater protection practices, oral and written communication and knowledge of code administration and enforcement procedures;

(h) For all applicants, knowledge of industry and national practices and state code requirements; and

(i) All applicants shall provide a signed statement which indicates that they know, understand and have a copy of the state code.

(5) GRADING OF EXAMINATIONS. The final grading of all examinations shall be by persons approved by the department. A grade of 70% or greater in each part shall be considered a passing grade for certification.

(6) EXAMINATION RETAKE. Applicants failing part or all of an examination shall be required to retake, within 2 years of the original examination, only that part failed. All applications for re-examination shall be filed with the department prior to the scheduled date of the examination to be retaken. Prior to the third consecutive retake of any examination or portion of an examination, the applicant shall attend a department approved educational course in the subject of the examination to be retaken. Applicants shall be allowed to take the same examination no more than 3 times in one year.

ILHR 10.918 ISSUANCE OF CERTIFICATE. (1) GENERAL Upon completing the requirements for certification, the department shall notify the applicant in writing and shall issue the appropriate certificate. The certificate shall bear the name of the applicant, certification number, expiration date, and certification category. The certificate shall be valid for a period of one year. The department shall issue the certificate within 30 business days of completion of the requirements for certification by the applicant.

(2) CERTIFICATION PERIOD. (a) Interim certificates issued as allowed by s. ILHR 10.912 (2) shall expire one year after the effective date of this chapter.

(b) The initial certification issued for any category to a person who is found eligible under s. ILHR 10.912 (1), shall be valid for a period of 2 years, subsequent certificates issued for the same category shall be valid for a period of 3 years.

ILHR 10.92 RENEWAL OF CERTIFICATE. Upon receipt of written notice of expiration, certification may be renewed. Certification renewal shall be contingent on receiving a passing grade on an examination. The department shall review and make a determination on an application for renewal of certification within 30 business days of receipt of the application for renewal and successful completion of the examination.

ILHR 10.922 DENIAL OF CERTIFICATION. (1) NOTICE OF DENIAL. Upon denial of certification or recertification, the department shall notify the applicant in writing stating the reasons for denial. The notice of denial shall be made by certified mail sent to the address filed with the application. Service shall be verified by the certified mail receipt. The department shall notify the applicant of denial of certification within 30 business days.

(2) HEARING. Upon receipt of denial, any applicant may submit a written request for hearing. The right to hearing shall be considered waived if the applicant fails to submit the request within 30 business days or receipt of the denial. The hearing will be conducted and the proceedings will be recorded by the department. The department shall conduct a hearing and make a determination within 30 business days of request for a hearing regarding denial of certification.

ILHR 10.923 REGISTRATION OF COMPANIES. Companies or other organizations that provide services that are required to be performed by certified persons shall be registered with the department. Application for registration shall be made in writing and shall include the names and certification numbers of certified employees. Registered organizations shall inform the department in writing within 30 business days of any change in the certification or employment status of the persons included in their registration application.

ILHR 10.9235 CERTIFICATION ADVISORY BOARD. The division of safety and buildings shall establish an advisory board to provide consultation on the certification process. The board shall be made up of 5 members and shall represent service users, the regulated community and the public.

### PART 3 - DUTIES OF CERTIFIED PERSONS

ILHR 10.924 SUPERVISION. (1) GENERAL. Storage tank system installation, removal, testing, relining, cleaning and site assessments shall be supervised by a person holding an appropriate certification.

(2) ON-SITE SUPERVISION POINTS. A person holding an appropriate certification shall be on-site at the following points for storage tank system installation, removal, cleaning, testing, relining and site assessments:

(a) Installation.

1. Soap test of tanks.
2. Inspection and repair of coatings.
3. Placing of bedding material, setting and bedding of tanks.
4. Backfilling operations and compaction of backfill around tanks and piping.
5. Installation of cathodic protection on piping or the installation of impressed current systems.
6. Installation and testing of all connections and tank related piping including vapor recovery, vents, and supply pipes.
7. Installation of leak detection and installation of any monitoring wells.
8. Testing of tanks and piping both prior to and after backfilling.



9. Hook up of pumps and dispensers.

(b) Removal.

1. Disconnection and draining of piping.

2. Capping of piping.

3. Vapor freeing or inerting of tanks.

4. Cleaning of tanks, if done on the premises, and handling of sludges and other waste.

5. Removal of tanks from the ground and loading for transport or the filling of the tank with an inert material, where allowed by the authorized agent.

6. Visual inspection of soils around excavation or tank location.

(c) Tightness testing. A certified tester shall be on-site for the full test process.

(d) Site assessment.

1. Calibration of field instruments.

2. Visual inspection of excavations.

3. Selection of sample sites.

4. Screening of samples with field instruments.

5. Taking of soil samples and handling in preparation for testing or shipment.

6. Conduct of field screenings.

7. Completion of plot plan, chain of custody forms, and other onsite recordkeeping.

(e) Lining.

1. Removal of product and vapor freeing or inerting of tanks.

2. Cutting of openings in tanks.

3. Removal and handling of sludges and other wastes from tanks.

4. Sand blasting of interior.

5. Inspection for holes and the thickness of the walls.

6. Repair of holes.
7. Coating of tanks.
8. Testing for holidays.
9. Measuring for thickness of coatings.
10. Testing for hardness of coating.
11. Resealing of tanks.

(f) Cleaning.

1. Vapor freeing or inserting of tanks.
2. Cleaning of the tanks and handling of sludges and other wastes.

ILHR 10.9245 CONFLICT OF INTEREST. When directed by the department or fire department or other authorized agent, tank system installation, removal, testing, lining, cleaning or site assessment shall be performed by certified persons without personal or monetary interest in the system and who's employer has no personal nor monetary interest in the system.

#### PART 4 - SUSPENSION AND REVOCATION

ILHR 10.925 SUSPENSION OR REVOCATION OF CERTIFICATION OR REGISTRATION.

The department may suspend or revoke the certification of any tank system installer, remover, tester, liner, cleaner, inspector or site assessment provider, or the registration of any company for any of the following reasons:

- (1) Fraud or deceit in obtaining certification.
- (2) Knowing, aiding or abetting the unauthorized installation, removal, cleaning, relining, testing or site assessment of UST systems by persons not certified by the department.
- (3) Any negligence, incompetence or misconduct in the discharge of the duties required under this chapter.
- (4) Conviction of a criminal charge, misdemeanor or local regulation substantially related to the circumstances of UST system installation, removal or testing activity or adjudication of mental incompetence by the courts.
- (5) Failure to comply with provisions of this chapter and adopted standards specified in ss. ILHR 10.25 and 10.26.

#### PART 5 - PROCEEDINGS

ILHR 10.926 FILING OF COMPLAINT. Proceedings to revoke or suspend a certificate or registration may be initiated by any person on a signed, written complaint filed with the department. Any alleged violation of the law or the administrative rules of the department shall be set forth in the complaint with particular reference to time, place and circumstance.

ILHR 10.928 INVESTIGATION AND NOTIFICATION. The department may investigate alleged violations on its own initiative or upon the filing of a complaint. The department shall make an investigation and a determination regarding a complaint within 3 months of receipt of the complaint. If it is determined that no further action is warranted, the department shall notify the persons affected. If the department determines that there is probable cause, it shall order a hearing. The department shall notify the persons affected, prior to holding the hearing.

ILHR 10.93 MAILING. Unless otherwise provided by law, all orders, notices and other papers may be served by the department by certified mail addressed to the party at the last known address. If the service is refused, service may be made by sheriff without amendment of the original order, notice or other paper.

ILHR 10.932 RESPONSE. Upon receipt of notification of hearing from the department, the charged party may submit to the department a written response within 30 days of the date of service. Failure to respond within the prescribed time limit, or failure to appear at the scheduled hearing, may result in the allegations specified in the complaint being taken as true.

ILHR 10.934 CONCILIATION AGREEMENT PRIOR TO HEARING. If the department and the respondent are able to reach agreement on disposition of a complaint prior to hearing, such agreement shall:

- (1) Be transmitted in writing to the secretary;
- (2) Not be binding upon any party until accepted by the secretary;
- (3) Not be considered a waiver of any defense nor an admission of any fact until accepted by the secretary.

ILHR 10.936 HEARINGS. (1) SUBPOENAS; WITNESS FEES. Subpoenas may be signed and issued by the department or the clerk of any court of record. Witness fees and mileage of witnesses subpoenaed on behalf of the department will be paid at the rate prescribed for witnesses in circuit court.

(2) CONDUCT OF HEARINGS. All hearings will be conducted by persons selected by the department. Persons so designated may administer oaths or affirmations and may grant continuances and adjournments for cause shown. The respondent shall appear in person and may be represented by an attorney-at-law. Witnesses may be examined by persons designated by the department.

ILHR 10.938 FINDINGS. The department may make findings and enter its order on the basis of the facts revealed by its investigation. Any findings as a result of petition or hearing shall be in writing and shall be binding unless appealed to the secretary.

ILHR 10.94 APPEAL ARGUMENTS. Appeal arguments shall be submitted to the department in writing unless otherwise ordered.

ILHR 10.942 PETITION FOR RULES OR DECLARATORY RULINGS. Petitions for the adoption, repeal or amendment of rules and for declaratory rulings shall be in accordance with ch. 227, Stats.

**APPENDIX A**

The material contained in this Appendix is for clarification only. The notes, illustrations, forms, etc., are numbered to correspond to the number of the rule as it appears in the text of the chapter.

A10.10 (4) (b) 2. and 3. DISPENSING EQUIPMENT PROGRAM CHECKLIST. The following sample format of a dispensing equipment agreement form/training program satisfies the subject requirements:

STATE OF WISCONSIN/DILHR/FIRE PREVENTION SECTION PROGRAM CHECKLIST

The following information relates to training of persons who will operate the key, card or code dispensing devices in accordance with ch. ILHR 10 - Flammable and Combustible Liquids Code, section ILHR 10.10 (4) (b) 2. and 3.

CARDTROL OPERATING INSTRUCTIONS

1. Turn off engine and extinguish all smoking materials.
2. Insert key, card or code into reader unit.
3. When "Select Pump" light comes on, push button to select desired pump.
4. Remove key or card from reader. You now have 80 seconds to start fueling before unit "times out".
5. Remove nozzle from selected pump and turn lever on.
6. After fueling, turn pump lever off and replace nozzle on pump.

SAFETY INSTRUCTIONS AGREEMENT

1. Always turn off engine before fueling.
2. Never smoke or use open flame devices in vicinity of pumps.
3. Never dispense gasoline into a glass container. Use only red metal containers or UL listed or classified containers for gasoline.
4. Never dispense diesel fuel into a red container.
5. Familiarize yourself with the locations of the fire extinguisher and emergency electrical cutoff switch.
6. To use fire extinguisher, break glass to gain access.
7. Follow instructions on the use of the fire extinguisher.
8. To disconnect electric power to pumps, break glass and pull switch on emergency shutoff located on the building.
9. The emergency telephone number is conspicuously posted at the site and customer agrees to call this number in case of a spill or if any other hazardous condition is found to exist.

AGREEMENTS: (special provisions between owner and member)

RESPONSIBILITY OF CUSTOMER: (use, payment, key-card control, etc.)

I certify that I received the instructions and training necessary for operation of \_\_\_\_\_ key, card or code dispensing unit.

Customer's signature \_\_\_\_\_ Date \_\_\_\_\_

Company representative signature \_\_\_\_\_ Date \_\_\_\_\_

A10.10 (6) APPLICATION FOR APPROVAL. The following form (SBD-9) is referred to in this section. Copies of this form are available from the Division of Safety and Buildings, P.O. Box 7969, Madison, Wisconsin 53707, or from the local fire department or authorized agent.

# FLAMMABLE LIQUID TANKS INSTALLATION APPLICATION

Application is made to the Department of Industry, Labor and Human Relations to (check all applicable boxes):

- |   |   |  |
|---|---|--|
| <input type="checkbox"/> Install tanks and/or lines | <input type="checkbox"/> Convert full service to self-service or convert to key-card-code | <input type="checkbox"/> Installation Of Piping Only |
| <input type="checkbox"/> Revise a plan              | <input type="checkbox"/> Upgrade for spill protection and/or overfill only                | <input type="checkbox"/> Reline Tanks                |

All work is to be done in accordance with the following detailed statement and attached plans subject to the orders of the Department of Industry, Labor and Human Relations. The installation, in all respects, will comply with applicable provisions of Chapter ILHR 10 of the Wisconsin Administrative Code (FLAMMABLE AND COMBUSTIBLE LIQUIDS).

**DIRECTIONS:**

Submit this form and four copies of the design and plot plan, along with the required fee to the address in the upper right corner of this page. The check is to be made out to: Safety & Buildings Division.

Each plan submittal must include a plot plan, drawn to scale (not smaller than 1" = 20') and showing (1) property lines, (2) buildings, (3) tanks, (4) piping, (5) load and unload racks OR pump islands, (6) streets and highways, (7) streams and bodies of water within 200 feet of tanks, (8) vehicular routes, (9) distances, (10) wells, (11) spill containment device, (12) overfill protection method, and (13) leak detection system to be used, including location of monitoring wells, if used. (If groundwater or vapor monitoring wells are used, data must be submitted to show that the installation complies with § 280.43 and 280.44.)

Two copies of the plans and a letter of conditional approval will be returned to you after approval.  
When a tank is relined, the "Quality Control Tank Lining Compliance Report" must be submitted to the Division after the relining is complete.  
A final inspection of the site must be performed by the local fire inspector or other authorized individual before the tank is covered and put into service.

**LOCATION:**

|  |  |                    |        |             |          |  |
|--|--|--------------------|--------|-------------|----------|--|
| Owner/Operator   |  | Establishment Name |        |             |          |  |
| Street Address   |  | City               | County | State<br>WI | Zip Code |  |
| Fire Department Providing Coverage Where Tank Is Located |  |                    |        |             |          |  |

**TANK SPECIFICATIONS: (each tank)**

|   | Horizontal | Vertical | Underground | Above Ground | Capacity | Length | Diameter | Contents | New | Used * | Gauge |
|---|------------|----------|-------------|--------------|----------|--------|----------|----------|-----|--------|-------|
| 1 |            |          |             |              |          |        |          |          |     |        |       |
| 2 |            |          |             |              |          |        |          |          |     |        |       |
| 3 |            |          |             |              |          |        |          |          |     |        |       |
| 4 |            |          |             |              |          |        |          |          |     |        |       |
| 5 |            |          |             |              |          |        |          |          |     |        |       |
| 6 |            |          |             |              |          |        |          |          |     |        |       |

|   |   |   |  |
|---|---|---|--|
| Is pump motor explosion proof? <input type="checkbox"/> Yes <input type="checkbox"/> No | Are pump switches Explosion proof? <input type="checkbox"/> Yes <input type="checkbox"/> No | Are bonds and grounding Provided at load/unload racks? <input type="checkbox"/> Yes <input type="checkbox"/> No | What type of overfill protection provided? |
| * If used, indicate what manufacturer has recertified the tank(s):                      |   |   | What type of spill containment device:     |

**UNDERGROUND TANKS:**

| Distance Buried:  | Size Of Fill Pipe:               | Size And Height Of Vent  | X  |                               |
|---|----------------------------------|--|--|-------------------------------|
| The tank is <input type="checkbox"/> Steel <input type="checkbox"/> Fiberglass <input type="checkbox"/> Other (specify) - |                                  | Approval: <input type="checkbox"/> Nat'l Std <input type="checkbox"/> UL <input type="checkbox"/> Other: | Doubled walled? <input type="checkbox"/> Yes <input type="checkbox"/> No |                               |
| Capacity Of Tank  | How Many Anodes (if steel tank)? | Size Of Anodes   | Specify: Dielectric Union Or Isolation Bushing                           | Name Of Approved Tank Coating |
| 1   |                                  |  | <input type="checkbox"/> DU <input type="checkbox"/> IB                  |                               |
| 2   |                                  |  | <input type="checkbox"/> DU <input type="checkbox"/> IB                  |                               |
| 3   |                                  |  | <input type="checkbox"/> DU <input type="checkbox"/> IB                  |                               |
| 4   |                                  |  | <input type="checkbox"/> DU <input type="checkbox"/> IB                  |                               |
| 5   |                                  |  | <input type="checkbox"/> DU <input type="checkbox"/> IB                  |                               |
| 6   |                                  |  | <input type="checkbox"/> DU <input type="checkbox"/> IB                  |                               |

**TANK LEAK DETECTION METHOD (location of all monitoring wells and/or monitors must be shown on plans)**

|   |   |  |  |
|---|---|--|--|
| <input type="checkbox"/> Automatic tank gauging   | <input type="checkbox"/> Vapor monitoring | <input type="checkbox"/> Groundwater monitoring  | <input type="checkbox"/> Interstitial monitoring |
| <input type="checkbox"/> Inventory control and tightness testing (every 5 years for 10 years) |   | <input type="checkbox"/> Manual Tank Gauging (only for tanks of 1,000 gallons or less) |  |

**PIPING:**

|  |                                      |  |  |
|--|--------------------------------------|--|--|
| The piping is <input type="checkbox"/> Steel <input type="checkbox"/> Fiberglass <input type="checkbox"/> Other (specify) -                |                                      | Approval: <input type="checkbox"/> Nat'l <input type="checkbox"/> UL <input type="checkbox"/> Other: | Doubled walled? <input type="checkbox"/> Yes <input type="checkbox"/> No |
| Corrosion protection for steel piping provided by: <input type="checkbox"/> Cathodic protection <input type="checkbox"/> Impressed current |                                      |  |  |
| Pipes coated? <input type="checkbox"/> Yes <input type="checkbox"/> No   | Name of approved coating (identify): |  |  |



**PIPING (continued):**

Indicate whether  Pressurized  Suction with check valve at tank  Suction with check valve inspectable directly below pump at dispenser  
 If pressurized piping, indicate if  Alarm  Flow restrictor  Auto shutoff Provide Model \_\_\_\_\_

**PIPING LEAK DETECTION METHOD (location of all monitoring wells and/or monitors must be shown on plans)**

If pressurized or check valve at tank, indicate leak detection method used  Vapor monitor  Interstitial monitoring  
 Groundwater monitoring  Tightness testing  Line Leak Detector

**ABOVE GROUND TANKS:**

|  |   |   |                                 |
|--|---|---|---------------------------------|
| Regular Vent Pressure/Vacuum   | Make  | Number  | Size                            |
| Emergency Relief Vent  | Make  | Number  | Size                            |
| Emergency Internal Valve   | Make  | Number  | Size                            |
| Diking provided? <input type="checkbox"/> Yes <input type="checkbox"/> No If no, provide tank material approval no.: _____ | Remote impounding? <input type="checkbox"/> Yes <input type="checkbox"/> No | Are the dike walls and base impervious?<br>Walls: <input type="checkbox"/> Yes <input type="checkbox"/> No Base: <input type="checkbox"/> Yes <input type="checkbox"/> No | Specify distance between tanks: |

**VERTICAL TANKS - LIST THICKNESS OF METAL:**

|    |        |     |                      |           |    |        |     |                      |           |
|----|--------|-----|----------------------|-----------|----|--------|-----|----------------------|-----------|
| 1. | Bottom | Top | Shell - Lower Course | Remainder | 4. | Bottom | Top | Shell - Lower Course | Remainder |
| 2. | Bottom | Top | Shell - Lower Course | Remainder | 5. | Bottom | Top | Shell - Lower Course | Remainder |
| 3. | Bottom | Top | Shell - Lower Course | Remainder | 6. | Bottom | Top | Shell - Lower Course | Remainder |

**FEES - IND 69:**

| <u>Installation Or Relining</u>   | <u>No. Of Tanks</u> | <u>Cost</u>        | <u>Sub Total</u> |
|---|---------------------|--------------------|------------------|
| Plan Examination - 1st Tank System or Component ...   | 1                   | X \$ 35.00 =       | \$ 35.00         |
| 2nd thru 10th System/Component, \$10.00 ea. ....<br>(Maximum charge = \$150.00 for 11 or more)                    |                     | X \$ 10.00 =       | +                |
| Total Plan Examination Fees .....   |                     | TOTAL =            | \$               |
| Site Inspection - \$50.00 for each tank system<br>or Component .....  |                     | X \$ 50.00 =       | \$               |
| Relining (includes inspection fee) .....  | Per Submission      | X \$ 65.00 =       | \$               |
| Self Service, Key-Card-Code Conversion .....  | Per Submission      | X \$ 78.00 =       | \$               |
| <b><u>Addition or Upgrade For Leak Detection; Spill Protection; Overfill Protection; Corrosion Protection</u></b> |                     |                    |                  |
| Plan Examination .....  |                     | \$22.00 =          | \$               |
| Site Inspection .....   |                     | \$43.00 =          | \$               |
| <b><u>REVISION OF PREVIOUSLY APPROVED PLAN</u></b> .....  |                     | \$22.00 =          | \$               |
| <b>GROUNDWATER SURCHARGE (Wis. Stat. 101.14 (5))</b> .....  |                     | =                  | \$ 100.00 *      |
| * Not required for spill, overfill, leak detection, corrosion protection reviews or plan revisions                |                     | <b>TOTAL FEE =</b> | \$               |

**WHERE SHOULD PLAN APPROVALS BE SENT?**

|   |                       |
|---|-----------------------|
| <input type="checkbox"/> Owner/ Operator <input type="checkbox"/> Installer | Name                  |
| Street Address  | City, State, Zip Code |

**CERTIFICATION:**

I certify by signature that provisions of the current Flammable and Combustible Liquids Code and 40 CFR Part 280, listed or not listed on this document, will be complied with. Also, no tank will be installed within 100 feet of a well (DNR Rule).

Signature \_\_\_\_\_

Date Signed \_\_\_\_\_

Telephone Number \_\_\_\_\_

A10.125 WISCONSIN BUILDING MATERIAL APPROVAL APPLICATION. The following form (SBD-8028) is referred to in this section. Copies of this form are available from the Division of Safety and Buildings, P.O. Box 7969, Madison, Wisconsin 53707.

# WISCONSIN BUILDING MATERIAL APPROVAL APPLICATION

Department of Industry, Labor and Human Relations  
Safety and Buildings Division  
201 East Washington Avenue, P.O. Box 7969  
Madison, Wisconsin 53707  
608/266-3151

**Instructions:** One application form per material approval. Type or print clearly. Make checks payable to: Safety and Buildings Division. Send application, fee and any additional information to address shown above.

| 1. Submitting Party Information                               | 2. Manufacturer Information                                   |
|---|---|
| Applicant Company   | Manufacturer (if same as applicant, write same)               |
| Applicant Address   | Manufacturer Address  |
| City                      State                      Zip Code | City                      State                      Zip Code |
| Contact Person, Telephone No.                                 | Contact Person, Telephone No.                                 |

**3. Product Information**

|   |             |
|---|-------------|
| Product: (e.g. Concrete Block, Metal Building, etc) | Trade Name: |
|---|-------------|

**Description and Use of Material:** (attach additional sheets if necessary)

**Submittal Type and Fee:** (check type and submit fee)

- New Approval (\$540.00)
- Renewal, With Changes (\$540.00)
- Renewal, No Changes (\$270.00)
- Minor Revision at Manufacturer's Request (\$60.00)  
(no extension of approval period)
- Major Revision at Manufacturer's Request (\$540.00)  
(new 5-year period)

Current Approval Number, if any: \_\_\_\_\_

**Wisconsin Code Sections Under Which Approval Is Requested:** (if known)

Determination of approval will be based on evidence which shows that the material performs in a manner which is equal or superior to the material required by the code sections listed above.

**PUBLIC RECORDS:** Department files and records may be subject to public inspection and copying unless they are designated as containing trade secrets. Do you wish your documents to be so designated? Yes \_\_\_ No \_\_\_

I affirm that the information submitted with this application is, to my knowledge and understanding, correct.

Signature of Applicant: \_\_\_\_\_ Date: \_\_\_\_\_

A10.13 NEW AND REPLACEMENT TANK REGISTRATION. The following forms (SBD-9, SBD-8731 and SBD 7437) are referred to in this section. Copies of this form are available from the Division of Safety and Buildings, P.O. Box 7969, Madison, Wisconsin 53707, or from the local fire department or authorized agent.

# FLAMMABLE LIQUID TANKS INSTALLATION APPLICATION

Application is made to the Department of Industry, Labor and Human Relations to (check all applicable boxes):

- |   |   |  |
|---|---|--|
| <input type="checkbox"/> Install tanks and/or lines | <input type="checkbox"/> Convert full service to self-service or convert to key-card-code | <input type="checkbox"/> Installation Of Piping Only |
| <input type="checkbox"/> Revise a plan              | <input type="checkbox"/> Upgrade for spill protection and/or overfill only                | <input type="checkbox"/> Reline Tanks                |

All work is to be done in accordance with the following detailed statement and attached plans subject to the orders of the Department of Industry, Labor and Human Relations. The installation, in all respects, will comply with applicable provisions of Chapter ILHR 10 of the Wisconsin Administrative Code (FLAMMABLE AND COMBUSTIBLE LIQUIDS).

**DIRECTIONS:**

Submit this form and four copies of the design and plot plan, along with the required fee to the address in the upper right corner of this page. The check is to be made out to: Safety & Buildings Division.

Each plan submittal must include a plot plan, drawn to scale (not smaller than 1" = 20') and showing (1) property lines, (2) buildings, (3) tanks, (4) piping, (5) load and unload racks OR pump islands, (6) streets and highways, (7) streams and bodies of water within 200 feet of tanks, (8) vehicular routes, (9) distances, (10) wells, (11) spill containment device, (12) overfill protection method, and (13) leak detection system to be used, including location of monitoring wells, if used. (If groundwater or vapor monitoring wells are used, data must be submitted to show that the installation complies with § 280.43 and 280.44.)

Two copies of the plans and a letter of conditional approval will be returned to you after approval.

When a tank is relined, the "Quality Control Tank Lining Compliance Report" must be submitted to the Division after the relining is complete.

A final inspection of the site must be performed by the local fire inspector or other authorized individual before the tank is covered and put into service.

|  |                    |
|--|--------------------|
| <b>LOCATION:</b>   |                    |
| Owner/Operator   | Establishment Name |
| Street Address   | City               |
|  | County             |
|  | State WI           |
|  | Zip Code           |
| Fire Department Providing Coverage Where Tank Is Located |                    |

| TANK SPECIFICATIONS: (each tank) |            |          |             |              |          |        |          |          |     |        |       |
|----------------------------------|------------|----------|-------------|--------------|----------|--------|----------|----------|-----|--------|-------|
|                                  | Horizontal | Vertical | Underground | Above Ground | Capacity | Length | Diameter | Contents | New | Used * | Gauge |
| 1                                |            |          |             |              |          |        |          |          |     |        |       |
| 2                                |            |          |             |              |          |        |          |          |     |        |       |
| 3                                |            |          |             |              |          |        |          |          |     |        |       |
| 4                                |            |          |             |              |          |        |          |          |     |        |       |
| 5                                |            |          |             |              |          |        |          |          |     |        |       |
| 6                                |            |          |             |              |          |        |          |          |     |        |       |

|   |   |   |  |
|---|---|---|--|
| Is pump motor explosion proof? <input type="checkbox"/> Yes <input type="checkbox"/> No | Are pump switches Explosion proof? <input type="checkbox"/> Yes <input type="checkbox"/> No | Are bonds and grounding Provided at load/unload racks? <input type="checkbox"/> Yes <input type="checkbox"/> No | What type of overfill protection provided? |
| * If used, indicate what manufacturer has recertified the tank(s):                      |   | What type of spill containment device:  |  |

| <b>UNDERGROUND TANKS:</b>   |                                  |                    |  |                               |  |
|---|----------------------------------|--------------------|--|-------------------------------|--|
| Distance Buried:  |                                  | Size Of Fill Pipe: |  | Size And Height Of Vent X     |  |
| The tank is <input type="checkbox"/> Steel <input type="checkbox"/> Fiberglass <input type="checkbox"/> Other (specify) - |                                  |                    | Approval: <input type="checkbox"/> Nat'l Std <input type="checkbox"/> UL <input type="checkbox"/> Other: |                               | Doubled walled? <input type="checkbox"/> Yes <input type="checkbox"/> No |
| Capacity Of Tank  | How Many Anodes (if steel tank)? | Size Of Anodes     | Specify: Dielectric Union Or Isolation Bushing   | Name Of Approved Tank Coating |  |
| 1   |                                  |                    | <input type="checkbox"/> DU <input type="checkbox"/> IB  |                               |  |
| 2   |                                  |                    | <input type="checkbox"/> DU <input type="checkbox"/> IB  |                               |  |
| 3   |                                  |                    | <input type="checkbox"/> DU <input type="checkbox"/> IB  |                               |  |
| 4   |                                  |                    | <input type="checkbox"/> DU <input type="checkbox"/> IB  |                               |  |
| 5   |                                  |                    | <input type="checkbox"/> DU <input type="checkbox"/> IB  |                               |  |
| 6   |                                  |                    | <input type="checkbox"/> DU <input type="checkbox"/> IB  |                               |  |

|   |   |  |  |
|---|---|--|--|
| <b>TANK LEAK DETECTION METHOD (location of all monitoring wells and/or monitors must be shown on plans)</b> |   |  |  |
| <input type="checkbox"/> Automatic tank gauging   | <input type="checkbox"/> Vapor monitoring | <input type="checkbox"/> Groundwater monitoring  | <input type="checkbox"/> Interstitial monitoring |
| <input type="checkbox"/> Inventory control and tightness testing (every 5 years for 10 years)               |   | <input type="checkbox"/> Manual Tank Gauging (only for tanks of 1,000 gallons or less) |  |

|  |  |                                      |  |  |  |
|--|--|--------------------------------------|--|--|--|
| <b>PIPING:</b>   |  |                                      |  |  |  |
| The piping is <input type="checkbox"/> Steel <input type="checkbox"/> Fiberglass <input type="checkbox"/> Other (specify) -                |  |                                      | Approval: <input type="checkbox"/> Nat'l <input type="checkbox"/> UL <input type="checkbox"/> Other: |  | Doubled walled? <input type="checkbox"/> Yes <input type="checkbox"/> No |
| Corrosion protection for steel piping provided by: <input type="checkbox"/> Cathodic protection <input type="checkbox"/> Impressed current |  |                                      |  |  |  |
| Pipes coated? <input type="checkbox"/> Yes <input type="checkbox"/> No   |  | Name of approved coating (identify): |  |  |  |

**PIPING (continued):**

Indicate whether  Pressurized  Suction with check valve at tank  Suction with check valve inspectable directly below pump at dispenser  
 If pressurized piping, indicate if  Alarm  Flow restrictor  Auto shutoff Provide Model \_\_\_\_\_

**PIPING LEAK DETECTION METHOD (location of all monitoring wells and/or monitors must be shown on plans)**

If pressurized or check valve at tank, indicate leak detection method used  Vapor monitor  Interstitial monitoring  
 Groundwater monitoring  Tightness testing  Line Leak Detector

**ABOVE GROUND TANKS:**

|  |   |   |                                 |
|--|---|---|---------------------------------|
| Regular Vent Pressure/Vacuum   | Make  | Number  | Size                            |
| Emergency Relief Vent  | Make  | Number  | Size                            |
| Emergency Internal Valve   | Make  | Number  | Size                            |
| Diking provided? <input type="checkbox"/> Yes <input type="checkbox"/> No If no, provide tank material approval no.: _____ | Remote Impounding? <input type="checkbox"/> Yes <input type="checkbox"/> No | Are the dike walls and base impervious?<br>Walls: <input type="checkbox"/> Yes <input type="checkbox"/> No Base: <input type="checkbox"/> Yes <input type="checkbox"/> No | Specify distance between tanks: |

**VERTICAL TANKS - LIST THICKNESS OF METAL:**

|    |        |     |                      |           |    |        |     |                      |           |
|----|--------|-----|----------------------|-----------|----|--------|-----|----------------------|-----------|
| 1. | Bottom | Top | Shell - Lower Course | Remainder | 4. | Bottom | Top | Shell - Lower Course | Remainder |
| 2. | Bottom | Top | Shell - Lower Course | Remainder | 5. | Bottom | Top | Shell - Lower Course | Remainder |
| 3. | Bottom | Top | Shell - Lower Course | Remainder | 6. | Bottom | Top | Shell - Lower Course | Remainder |

**FEES - IND 69:**

| <u>Installation Or Relining</u>   | <u>No. Of Tanks</u> | <u>Cost</u>  | <u>Sub Total</u> |
|---|---------------------|--------------|------------------|
| Plan Examination - 1st Tank System or Component ...   | 1                   | X \$ 35.00 = | \$ 35.00         |
| 2nd thru 10th System/Component, \$10.00 ea. ....<br>(Maximum charge = \$150.00 for 11 or more)                    |                     | X \$ 10.00 = | +                |
| Total Plan Examination Fees .....   |                     | TOTAL =      | \$               |
| Site Inspection - \$50.00 for each tank system or Component .....   |                     | X \$ 50.00 = | \$               |
| Relining (includes inspection fee) .....  | Per Submission      | X \$ 65.00 = | \$               |
| Self Service, Key-Card-Code Conversion .....  | Per Submission      | X \$ 78.00 = | \$               |
| <b><u>Addition or Upgrade For Leak Detection; Spill Protection; Overfill Protection; Corrosion Protection</u></b> |                     |              |                  |
| Plan Examination .....  |                     | \$22.00 =    | \$               |
| Site Inspection .....   |                     | \$43.00 =    | \$               |
| <b><u>REVISION OF PREVIOUSLY APPROVED PLAN</u></b> .....  |                     | \$22.00 =    | \$               |
| GROUNDWATER SURCHARGE (Wis. Stat. 101.14 (5)) .....   |                     | =            | \$ 100.00 *      |
| * Not required for spill, overfill, leak detection, corrosion protection reviews or plan revisions                |                     | TOTAL FEE =  | \$               |

**WHERE SHOULD PLAN APPROVALS BE SENT?**

|  |                       |
|--|-----------------------|
| <input type="checkbox"/> Owner/Operator <input type="checkbox"/> Installer | Name                  |
| Street Address   | City, State, Zip Code |

**CERTIFICATION:**

I certify by signature that provisions of the current Flammable and Combustible Liquids Code and 40 CFR Part 280, listed or not listed on this document, will be complied with. Also, no tank will be installed within 100 feet of a well (DNR Rule).

\_\_\_\_\_  
Signature Date Signed Telephone Number

# ABOVEGROUND PETROLEUM PRODUCT TANK INVENTORY

Send Completed Form To:  
Safety & Buildings Division  
P.O. Box 7969  
Madison, WI 53707  
Telephone (608) 267-5280

**For Office Use Only:**  
Tank ID # \_\_\_\_\_

This form must be completed pursuant to s. 101.142, Wis. Stats., to register an above ground petroleum product storage system. An aboveground petroleum product storage system is an **aboveground** tank, used to store petroleum products, together with an on-site integral piping or dispensing system. **Not included** are pipeline facilities, tanks of 110 gallons or less capacity, farm and residential tanks of 1,100 gallons or less capacity, tanks used for storing heating oil for consumptive use on the premises where stored or tanks owned by the state or federal government. **A separate form is needed for each tank. Send each completed form to the address in the top right corner.**

|   |  |
|---|--|
| This registration applies to a tank that is (check one):<br>1. <input type="checkbox"/> In Use<br>2. <input type="checkbox"/> Out of Service With Product<br>3. <input type="checkbox"/> Out of Service With No Product (Empty) | Fire Department Providing Fire Coverage Where Tank Is Located:<br><input type="checkbox"/> City <input type="checkbox"/> Village <input type="checkbox"/> Town of: _____ |
| 4. <input type="checkbox"/> Closed - Tank Removed<br>5. <input type="checkbox"/> Closed - Tank Cleaned<br>6. <input type="checkbox"/> Changed Ownership (Indicate new owner in section A. 3. below)                             |  |

**A. IDENTIFICATION (Please Print)**

|   |                            |  |
|---|----------------------------|--|
| 1. Tank Site Name   | Site Mailing Address       | Site Telephone Number<br>(    )        |
| <input type="checkbox"/> City <input type="checkbox"/> Village <input type="checkbox"/> Town of: _____  | State _____ Zip Code _____ | County _____                           |
| 2. Owner Name (mail sent here unless indicated otherwise in #3)   |                            |  |
| <input type="checkbox"/> City <input type="checkbox"/> Village <input type="checkbox"/> Town of: _____  | State _____ Zip Code _____ | County _____                           |
| 3. Alternate Mailing Name If Different Than #2  |                            |  |
| <input type="checkbox"/> City <input type="checkbox"/> Village <input type="checkbox"/> Town of: _____  | State _____ Zip Code _____ | County _____                           |
| 4. Tank Age (date installed, if new; years old, if used)  | 5. Tank Capacity (gal.)    | 6. Tank Manufacturer's Name (if known) |
| 7. If more than 1 tank is being reported at a facility, provide an 8 1/2 x 11 plot plan drawn to scale (1" = 20 ft.), numbering and indicating the location of the tanks being reported. If a plot plan is being submitted, this form is for tank number: _____ |                            |  |

**B. TYPE OF USER (check one):**

|  |   |                                     |   |
|--|---|-------------------------------------|---|
| 1. <input type="checkbox"/> Gas Station (any resale) | 2. <input type="checkbox"/> Bulk Storage            | 3. <input type="checkbox"/> Utility | 4. <input type="checkbox"/> Mercantile / Commercial |
| 5. <input type="checkbox"/> Industrial               | 6. <input type="checkbox"/> Government              | 7. <input type="checkbox"/> School  | 8. <input type="checkbox"/> Residential             |
| 9. <input type="checkbox"/> Agricultural             | 10. <input type="checkbox"/> Other (specify): _____ |                                     |   |

**C. TANK CONSTRUCTION (check one):**

|  |  |   |                                      |
|--|--|---|--------------------------------------|
| 1. <input type="checkbox"/> Bare Steel   | 2. <input type="checkbox"/> FRP Clad Steel | 3. <input type="checkbox"/> Steel With Lining | 4. <input type="checkbox"/> Concrete |
| 5. <input type="checkbox"/> Other (specify): _____   |  |   |                                      |
| Tank is built to: <input type="checkbox"/> National Standard _____ or <input type="checkbox"/> UL Approval or <input type="checkbox"/> Other _____ |  |   |                                      |

**D. ROOF (Check one):**

|  |   |   |   |
|--|---|---|---|
| 1. <input type="checkbox"/> Fixed Roof | 2. <input type="checkbox"/> Floating External | 3. <input type="checkbox"/> Floating Internal | 4. <input type="checkbox"/> Other _____ |
|--|---|---|---|

**E. TANK BASE:**

|  |   |                                       |                                      |
|--|---|---------------------------------------|--------------------------------------|
| 1. <input type="checkbox"/> On Ground  | 2. <input type="checkbox"/> On Supports | 3. <input type="checkbox"/> On Cement | 4. <input type="checkbox"/> On Liner |
| 5. <input type="checkbox"/> Double Bottom    6. <input type="checkbox"/> Other _____ |   |                                       |                                      |

**F. PIPING:**

|   |  |  |
|---|--|--|
| <input type="checkbox"/> Aboveground  | <input type="checkbox"/> Underground   | <input type="checkbox"/> Both            |
| Above Ground Piping Construction: <input type="checkbox"/> Steel <input type="checkbox"/> Other _____ |  |  |
| Underground Piping Construction:  |  |  |
| 1. <input type="checkbox"/> Bare Steel  | 2. <input type="checkbox"/> Cathodically Protected and coated or Wrapped Steel (a. <input type="checkbox"/> Sacrificial Anodes or b. <input type="checkbox"/> Impressed Current) | 3. <input type="checkbox"/> Coated Steel |
| 4. <input type="checkbox"/> Fiberglass  | 5. <input type="checkbox"/> Other (specify): _____   | 6. <input type="checkbox"/> Unknown      |

**G. CONTAINMENT:**

Dike Side Material: 1.  Block    2.  Concrete    3.  Earth    4.  Synthetic

Dike Base Material: 1.  Concrete    2.  Engineered Clay - Thickness \_\_\_\_\_    3.  Earth    4.  Synthetic- Make & Model #:

Remote Impounding?  Yes  No

**H. DISTANCE FROM DIKE WALL TO NEAREST:**

1. Well \_\_\_\_\_ Ft.    2. Property Line \_\_\_\_\_ Ft.    3. Surface Water \_\_\_\_\_ Ft.    4. Nearest Building On Property \_\_\_\_\_ Ft.

**I. TANK CONTENTS**

|                                       |  |   |                                      |
|---------------------------------------|--|---|--------------------------------------|
| 1. <input type="checkbox"/> Diesel    | 2. <input type="checkbox"/> Leaded     | 3. <input type="checkbox"/> Unleaded    | 4. <input type="checkbox"/> Fuel Oil |
| 5. <input type="checkbox"/> Gasohol   | 6. <input type="checkbox"/> Other      | 7. <input type="checkbox"/> Empty       | 9. <input type="checkbox"/> Unknown  |
| 10. <input type="checkbox"/> Premix   | 11. <input type="checkbox"/> Waste Oil | 13. <input type="checkbox"/> Chemical * |                                      |
| 14. <input type="checkbox"/> Kerosene | 15. <input type="checkbox"/> Aviation  |   |                                      |

\* If # 13 is checked, indicate the chemical name(s) or number(s) of the chemical or waste.

|  |                    |              |
|--|--------------------|--------------|
| If Tank Was Removed or Cleaned For Other Use, Give Date (mo/day/yr): | Owner's Signature: | Date Signed: |
|  |                    |              |

## UNDERGROUND PETROLEUM PRODUCT TANK INVENTORY

Send Completed Form To:  
Safety & Buildings Division  
P.O. Box 7969  
Madison, WI 53707  
Telephone (608) 267-5280

**For Office Use Only:**  
Tank ID #

This form is to be completed pursuant to Section 101.142, Wis. Stats., to register all underground tanks in Wisconsin that have stored or currently store petroleum or regulated substances. Please see the reverse side for additional information on this program. An underground storage tank is defined as any tank with at least 10 percent of its total volume (included piping) located below ground level. A separate form is needed for each tank. Send each completed form to the agency designated in the top right corner.

|  |   |   |  |
|--|---|---|--|
| This registration applies to a tank that is (check one):               |   |   | Fire Department Providing Fire Coverage<br>Where Tank Located: |
| 1. <input type="checkbox"/> In Use or New                              | 4. <input type="checkbox"/> Closed - Tank Removed               | 8. <input type="checkbox"/> Changed Ownership<br>(Indicate new owner below) |  |
| 2. <input type="checkbox"/> Abandoned With Product                     | 6. <input type="checkbox"/> Closed - Filled With Inert Material |   |  |
| 3. <input type="checkbox"/> Abandoned No Product (empty) or With Water | 7. <input type="checkbox"/> Out of Service                      |   |  |

**A. IDENTIFICATION: (Please Print)**

|   |                                  |  |   |                           |        |
|---|----------------------------------|--|---|---------------------------|--------|
| 1. Tank Site Name   |                                  | Site Mailing Address                   |   | Site Telephone No.<br>( ) |        |
| <input type="checkbox"/> City   | <input type="checkbox"/> Village | <input type="checkbox"/> Town of:      | State   | Zip Code                  | County |
| 2. Owner Name (mail sent here unless indicated otherwise in #3 below) |                                  |  | Owner Mailing Address (mail sent here unless indicated otherwise in #3) |                           |        |
| <input type="checkbox"/> City   | <input type="checkbox"/> Village | <input type="checkbox"/> Town of:      | State   | Zip Code                  | County |
| 3. Alternate Mailing Name If Different Than #2                        |                                  |  | Alternate Mailing Street Address If Different From #2                   |                           |        |
| <input type="checkbox"/> City   | <input type="checkbox"/> Village | <input type="checkbox"/> Town of:      | State   | Zip Code                  | County |
| 4. Tank Age (date installed, if known: or years old)                  | 5. Tank Capacity (gallons)       | 6. Tank Manufacturer's Name (if known) |   |                           |        |

**B. TYPE OF USER (check one):**

|  |   |                                     |   |
|--|---|-------------------------------------|---|
| 1. <input type="checkbox"/> Gas Station  | 2. <input type="checkbox"/> Bulk Storage            | 3. <input type="checkbox"/> Utility | 4. <input type="checkbox"/> Mercantile  |
| 5. <input type="checkbox"/> Industrial   | 6. <input type="checkbox"/> Government              | 7. <input type="checkbox"/> School  | 8. <input type="checkbox"/> Residential |
| 9. <input type="checkbox"/> Agricultural | 10. <input type="checkbox"/> Other (specify): _____ |                                     |   |

**C. TANK CONSTRUCTION:**

|  |   |
|--|---|
| 1. <input type="checkbox"/> Bare Steel   | 2. <input type="checkbox"/> Cathodically Protected and Coated Steel (A. <input type="checkbox"/> Sacrificial Anodes or B. <input type="checkbox"/> Impressed Current) |
| 3. <input type="checkbox"/> Coated Steel | 4. <input type="checkbox"/> Fiberglass  |
| 6. <input type="checkbox"/> Relined      | 7. <input type="checkbox"/> Steel - Fiberglass Reinforced Plastic Composite   |
|  | 9. <input type="checkbox"/> Unknown   |

Approval: 1.  Nat'l Std. 2.  UL 3.  Other: \_\_\_\_\_

Is Tank Double Walled?  Yes  No

Overfill Protection Provided?  Yes  No If yes, identify type: \_\_\_\_\_

Spill Containment?  Yes  No

Tank leak detection method: 1.  Automatic tank gauging 2.  Vapor monitoring 3.  Groundwater monitoring 4.  Inventory control and tightness testing 5.  Interstitial monitoring 6.  Not required at present 7.  Manual Tank Gauging (only for tanks of 1,000 gallons or less)

**D. PIPING CONSTRUCTION**

|  |  |  |
|--|--|--|
| 1. <input type="checkbox"/> Bare Steel | 2. <input type="checkbox"/> Cathodically Protected and Coated or Wrapped Steel (A. <input type="checkbox"/> Sacrificial Anodes or B. <input type="checkbox"/> Impressed Current) | 3. <input type="checkbox"/> Coated Steel |
| 4. <input type="checkbox"/> Fiberglass | 5. <input type="checkbox"/> Other (specify): _____   | 9. <input type="checkbox"/> Unknown      |

Piping System Type: 1.  Pressurized piping with: A.  auto shutoff; B.  alarm; or C.  flow restrictor 2.  Suction piping with check valve at tank 3.  Suction piping with check valve at pump and inspectable

Piping leak detection method: used if pressurized or check valve at tank: 1.  Vapor monitoring 2.  Interstitial monitoring 3.  Groundwater monitoring 4.  Tightness testing 5.  Line Leak Detector 6.  Not Required

Approval: 1.  Nat'l Std 2.  UL 3.  Other: \_\_\_\_\_

Double Walled:  Yes  No

**E. TANK CONTENTS**

|   |                                     |  |  |
|---|-------------------------------------|--|--|
| 1. <input type="checkbox"/> Diesel      | 2. <input type="checkbox"/> Leaded  | 3. <input type="checkbox"/> Unleaded   | 4. <input type="checkbox"/> Fuel Oil           |
| 5. <input type="checkbox"/> Gasohol     | 6. <input type="checkbox"/> Other   | 7. <input type="checkbox"/> Empty      | 8. <input type="checkbox"/> Sand/Gravel/Slurry |
| 9. <input type="checkbox"/> Unknown     | 10. <input type="checkbox"/> Premix | 11. <input type="checkbox"/> Waste Oil | 12. <input type="checkbox"/> Propane           |
| 13. <input type="checkbox"/> Chemical * |                                     | 14. <input type="checkbox"/> Kerosene  | 15. <input type="checkbox"/> Aviation          |

\* If # 13 is checked, indicate the chemical name(s) or number(s) of the chemical or waste.

|  |  |
|--|--|
| If Tank Closed, Give Date (mo/day/yr): | Has a site assessment been completed? (see reverse side for details)<br><input type="checkbox"/> Yes <input type="checkbox"/> No |
|--|--|

If installation of a new tank is being reported, indicate who performed the installation inspection:

|   |                                   |  |
|---|-----------------------------------|--|
| 1. <input type="checkbox"/> Fire Department | 2. <input type="checkbox"/> DILHR | 3. <input type="checkbox"/> Other (identify) _____ |
|---|-----------------------------------|--|

|   |  |
|---|--|
| Name of Owner or Operator (please print): | Indicate Whether:<br><input type="checkbox"/> Owner or <input type="checkbox"/> Operator |
| Signature of Owner or Operator:           | Date Signed:   |



## BACKGROUND FOR TANK INVENTORY

On May 4, 1984, legislation commonly known as the Ground Water Protection Act was signed into law. This legislation required the creation of an inventory of underground petroleum product storage tanks. A record of this information was necessitated by numerous reported incidents of ground water contamination by petroleum products. Many tanks have been installed, used and forgotten. These installations can threaten the ground water.

This underground tank inventory is being established to help identify the need for future actions required to clear up potential problems before they occur. Your help in identifying abandoned, "in use" and "new use" tank locations will greatly assist this effort to protect Wisconsin's ground water.

### SITE ASSESSMENT INFORMATION

Requirements for a site assessment at the closure or change in service for a federally regulated underground storage tank were outlined in federal rules published in the September 23, 1988 Federal Register, 40 CFR 280 and 281.

The requirements in § 280.72 state:

(a) Before permanent closure or a change-in-service is completed, owners and operators must measure for the presence of a release where contamination is most likely to be present at the UST site. In selecting sample types, sample locations, and measurement methods, owners and operators must consider the method of closure, the nature of the stored substance, the type of backfill, the depth to ground water, and other factors appropriate for identifying the presence of a release. The requirements of this section are satisfied if one of the external release detection methods allowed in § 280.43 (e) and (f) is operating in accordance with the requirements in § 280.43 at the time of closure, and indicates no release has occurred.

The external release detection methods in § 280.43 (e) and (f) are summarized below:

*"(e) Vapor monitoring."* This sub section refers to the testing or monitoring for vapors within the soil gas of the tank's excavation zone. It further requires seven (7) conditions to be met to qualify the testing program as a valid vapor monitoring system.

*"(f) Ground-water monitoring."* This sub section refers to the testing or monitoring for liquids on the ground water below the tank. It establishes the requirements for an acceptable system that effectively monitors the ground water for the presence of regulated substances and insures the integrity of the monitoring wells so the wells themselves do not become conduits for ground water contamination.

Complete written guidelines on the conduct of a site assessment can be obtained from the DILHR Bureau of Petroleum Inspection & Fire Protection at the following address:

Bureau of Petroleum Inspection and Fire Protection  
P.O. Box 7969  
Madison, WI 53707

Site assessments are to be submitted to both the DILHR office and to the DNR at the following addresses:

Bureau of Petroleum Inspection & Fire Protection  
P.O. Box 7969  
Madison, WI 53707

Bureau of Solid and Hazardous Waste Management  
P.O. Box 7921  
Madison, WI 53707

A10.14 EXISTING TANK REGISTRATION. The following forms (SBD-7437, SBD-8731 and SBD-7658) are referred to in this section. Copies of these forms are available from the Division of Safety and Buildings, P.O. Box 7969, Madison, Wisconsin 53707, or from the local fire department or authorized agent.

## UNDERGROUND PETROLEUM PRODUCT TANK INVENTORY

Send Completed Form To:  
Safety & Buildings Division  
P.O. Box 7969  
Madison, WI 53707  
Telephone (608) 267-5280

**For Office Use Only:**  
Tank ID #

This form is to be completed pursuant to Section 101.142, Wis. Stats., to register all underground tanks in Wisconsin that have stored or currently store petroleum or regulated substances. Please see the reverse side for additional information on this program. An underground storage tank is defined as any tank with at least 10 percent of its total volume (included piping) located below ground level. A separate form is needed for each tank. Send each completed form to the agency designated in the top right corner.

|  |   |   |  |
|--|---|---|--|
| This registration applies to a tank that is (check one): |   |   | Fire Department Providing Fire Coverage<br>Where Tank Located: |
| 1. <input type="checkbox"/> In Use or New                | 4. <input type="checkbox"/> Closed - Tank Removed               | 8. <input type="checkbox"/> Changed Ownership<br>(Indicate new owner below) |  |
| 2. <input type="checkbox"/> Abandoned With Product       | 6. <input type="checkbox"/> Closed - Filled With Inert Material | 7. <input type="checkbox"/> Out of Service                                  |  |

**A. IDENTIFICATION: (Please Print)**

|   |                                  |  |   |                           |        |
|---|----------------------------------|--|---|---------------------------|--------|
| 1. Tank Site Name   |                                  | Site Mailing Address                   |   | Site Telephone No.<br>( ) |        |
| <input type="checkbox"/> City   | <input type="checkbox"/> Village | <input type="checkbox"/> Town of:      | State   | Zip Code                  | County |
| 2. Owner Name (mail sent here unless indicated otherwise in #3 below) |                                  |  | Owner Mailing Address (mail sent here unless indicated otherwise in #3) |                           |        |
| <input type="checkbox"/> City   | <input type="checkbox"/> Village | <input type="checkbox"/> Town of:      | State   | Zip Code                  | County |
| 3. Alternate Mailing Name If Different Than #2                        |                                  |  | Alternate Mailing Street Address If Different From #2                   |                           |        |
| <input type="checkbox"/> City   | <input type="checkbox"/> Village | <input type="checkbox"/> Town of:      | State   | Zip Code                  | County |
| 4. Tank Age (date installed, if known: or years old)                  | 5. Tank Capacity (gallons)       | 6. Tank Manufacturer's Name (if known) |   |                           |        |

**B. TYPE OF USER (check one):**

|  |   |                                     |   |
|--|---|-------------------------------------|---|
| 1. <input type="checkbox"/> Gas Station  | 2. <input type="checkbox"/> Bulk Storage            | 3. <input type="checkbox"/> Utility | 4. <input type="checkbox"/> Mercantile  |
| 5. <input type="checkbox"/> Industrial   | 6. <input type="checkbox"/> Government              | 7. <input type="checkbox"/> School  | 8. <input type="checkbox"/> Residential |
| 9. <input type="checkbox"/> Agricultural | 10. <input type="checkbox"/> Other (specify): _____ |                                     |   |

**C. TANK CONSTRUCTION:**

|  |   |
|--|---|
| 1. <input type="checkbox"/> Bare Steel             | 2. <input type="checkbox"/> Cathodically Protected and Coated Steel (A. <input type="checkbox"/> Sacrificial Anodes or B. <input type="checkbox"/> Impressed Current) |
| 3. <input type="checkbox"/> Coated Steel           | 4. <input type="checkbox"/> Fiberglass  |
| 6. <input type="checkbox"/> Relined                | 7. <input type="checkbox"/> Steel - Fiberglass Reinforced Plastic Composite   |
| 5. <input type="checkbox"/> Other (specify): _____ |   |
| 9. <input type="checkbox"/> Unknown                |   |

Approval: 1.  Nat'l Std. 2.  UL 3.  Other: \_\_\_\_\_

Is Tank Double Walled?  Yes  No

Overfill Protection Provided?  Yes  No If yes, identify type: \_\_\_\_\_

Spill Containment?  Yes  No

Tank leak detection method: 1.  Automatic tank gauging 2.  Vapor monitoring 3.  Groundwater monitoring 4.  Inventory control and tightness testing 5.  Interstitial monitoring 6.  Not required at present 7.  Manual Tank Gauging (only for tanks of 1,000 gallons or less)

**D. PIPING CONSTRUCTION**

|  |  |  |
|--|--|--|
| 1. <input type="checkbox"/> Bare Steel | 2. <input type="checkbox"/> Cathodically Protected and Coated or Wrapped Steel (A. <input type="checkbox"/> Sacrificial Anodes or B. <input type="checkbox"/> Impressed Current) | 3. <input type="checkbox"/> Coated Steel |
| 4. <input type="checkbox"/> Fiberglass | 5. <input type="checkbox"/> Other (specify): _____   | 9. <input type="checkbox"/> Unknown      |

Piping System Type: 1.  Pressurized piping with: A.  auto shutoff; B.  alarm; or C.  flow restrictor 2.  Suction piping with check valve at tank 3.  Suction piping with check valve at pump and inspectable

Piping leak detection method: used if pressurized or check valve at tank: 1.  Vapor monitoring 2.  Interstitial monitoring 3.  Groundwater monitoring 4.  Tightness testing 5.  Line Leak Detector 6.  Not Required

Approval: 1.  Nat'l Std 2.  UL 3.  Other: \_\_\_\_\_

Double Walled:  Yes  No

**E. TANK CONTENTS**

|   |                                       |  |  |
|---|---------------------------------------|--|--|
| 1. <input type="checkbox"/> Diesel      | 2. <input type="checkbox"/> Leaded    | 3. <input type="checkbox"/> Unleaded   | 4. <input type="checkbox"/> Fuel Oil           |
| 5. <input type="checkbox"/> Gasohol     | 6. <input type="checkbox"/> Other     | 7. <input type="checkbox"/> Empty      | 8. <input type="checkbox"/> Sand/Gravel/Slurry |
| 9. <input type="checkbox"/> Unknown     | 10. <input type="checkbox"/> Premix   | 11. <input type="checkbox"/> Waste Oil | 12. <input type="checkbox"/> Propane           |
| 13. <input type="checkbox"/> Chemical * | 14. <input type="checkbox"/> Kerosene | 15. <input type="checkbox"/> Aviation  |  |

\* If # 13 is checked, indicate the chemical name(s) or number(s) of the chemical or waste.

|  |  |
|--|--|
| If Tank Closed, Give Date (mo/day/yr): | Has a site assessment been completed? (see reverse side for details)<br><input type="checkbox"/> Yes <input type="checkbox"/> No |
|--|--|

|  |  |
|--|--|
| If installation of a new tank is being reported, indicate who performed the installation inspection: |  |
| 1. <input type="checkbox"/> Fire Department  | 2. <input type="checkbox"/> DILHR  |
| 3. <input type="checkbox"/> Other (identify) _____   |  |
| Name of Owner or Operator (please print):  | Indicate Whether:<br><input type="checkbox"/> Owner or <input type="checkbox"/> Operator |
| Signature of Owner or Operator:  | Date Signed:   |

## BACKGROUND FOR TANK INVENTORY

On May 4, 1984, legislation commonly known as the Ground Water Protection Act was signed into law. This legislation required the creation of an inventory of underground petroleum product storage tanks. A record of this information was necessitated by numerous reported incidents of ground water contamination by petroleum products. Many tanks have been installed, used and forgotten. These installations can threaten the ground water.

This underground tank inventory is being established to help identify the need for future actions required to clear up potential problems before they occur. Your help in identifying abandoned, "in use" and "new use" tank locations will greatly assist this effort to protect Wisconsin's ground water.

### SITE ASSESSMENT INFORMATION

Requirements for a site assessment at the closure or change in service for a federally regulated underground storage tank were outlined in federal rules published in the September 23, 1988 Federal Register, 40 CFR 280 and 281.

The requirements in § 280.72 state:

(a) Before permanent closure or a change-in-service is completed, owners and operators must measure for the presence of a release where contamination is most likely to be present at the UST site. In selecting sample types, sample locations, and measurement methods, owners and operators must consider the method of closure, the nature of the stored substance, the type of backfill, the depth to ground water, and other factors appropriate for identifying the presence of a release. The requirements of this section are satisfied if one of the external release detection methods allowed in § 280.43 (e) and (f) is operating in accordance with the requirements in § 280.43 at the time of closure, and indicates no release has occurred.

The external release detection methods in § 280.43 (e) and (f) are summarized below:

"(e) *Vapor monitoring.*" This sub section refers to the testing or monitoring for vapors within the soil gas of the tank's excavation zone. It further requires seven (7) conditions to be met to qualify the testing program as a valid vapor monitoring system.

"(f) *Ground-water monitoring.*" This sub section refers to the testing or monitoring for liquids on the ground water below the tank. It establishes the requirements for an acceptable system that effectively monitors the ground water for the presence of regulated substances and insures the integrity of the monitoring wells so the wells themselves do not become conduits for ground water contamination.

Complete written guidelines on the conduct of a site assessment can be obtained from the DILHR Bureau of Petroleum Inspection & Fire Protection at the following address:

Bureau of Petroleum Inspection and Fire Protection  
P.O. Box 7969  
Madison, WI 53707

Site assessments are to be submitted to both the DILHR office and to the DNR at the following addresses:

Bureau of Petroleum Inspection & Fire Protection  
P.O. Box 7969  
Madison, WI 53707

Bureau of Solid and Hazardous Waste Management  
P.O. Box 7921  
Madison, WI 53707

# ABOVEGROUND PETROLEUM PRODUCT TANK INVENTORY

Send Completed Form To:  
Safety & Buildings Division  
P.O. Box 7969  
Madison, WI 53707  
Telephone (608) 267-5280

**For Office Use Only:**  
Tank ID # \_\_\_\_\_

This form must be completed pursuant to s. 101.142, Wis. Stats., to register an above ground petroleum product storage system. An aboveground petroleum product storage system is an **aboveground** tank, used to store petroleum products, together with an on-site integral piping or dispensing system. **Not included** are pipeline facilities, tanks of 110 gallons or less capacity, farm and residential tanks of 1,100 gallons or less capacity, tanks used for storing heating oil for consumptive use on the premises where stored or tanks owned by the state or federal government. **A separate form is needed for each tank. Send each completed form to the address in the top right corner.**

|  |  |
|--|--|
| This registration applies to a tank that is (check one):<br>1. <input type="checkbox"/> In Use<br>2. <input type="checkbox"/> Out of Service With Product<br>3. <input type="checkbox"/> Out of Service With No Product (Empty)<br>4. <input type="checkbox"/> Closed - Tank Removed<br>5. <input type="checkbox"/> Closed - Tank Cleaned<br>6. <input type="checkbox"/> Changed Ownership (Indicate new owner in section A. 3. below) | Fire Department Providing Fire Coverage Where Tank Is Located:<br><input type="checkbox"/> City <input type="checkbox"/> Village <input type="checkbox"/> Town of: _____ |
|--|--|

**A. IDENTIFICATION (Please Print)**

|   |                            |  |
|---|----------------------------|--|
| 1. Tank Site Name   | Site Mailing Address       | Site Telephone Number<br>(    )        |
| <input type="checkbox"/> City <input type="checkbox"/> Village <input type="checkbox"/> Town of: _____  | State _____ Zip Code _____ | County _____                           |
| 2. Owner Name (mail sent here unless indicated otherwise in #3)   |                            |  |
| Owner Mailing Address (mail sent here unless indicated otherwise in #3)   |                            |  |
| <input type="checkbox"/> City <input type="checkbox"/> Village <input type="checkbox"/> Town of: _____  | State _____ Zip Code _____ | County _____                           |
| 3. Alternate Mailing Name If Different Than #2  |                            |  |
| Alternate Mailing Street Address If Different Than #2   |                            |  |
| <input type="checkbox"/> City <input type="checkbox"/> Village <input type="checkbox"/> Town of: _____  | State _____ Zip Code _____ | County _____                           |
| 4. Tank Age (date installed, if new; years old, if used)  | 5. Tank Capacity (gal.)    | 6. Tank Manufacturer's Name (if known) |
| 7. If more than 1 tank is being reported at a facility, provide an 8 1/2 x 11 plot plan drawn to scale (1" = 20 ft.), numbering and indicating the location of the tanks being reported. If a plot plan is being submitted, this form is for tank number: _____ |                            |  |

**B. TYPE OF USER (check one):**

|  |   |                                     |   |
|--|---|-------------------------------------|---|
| 1. <input type="checkbox"/> Gas Station (any resale) | 2. <input type="checkbox"/> Bulk Storage            | 3. <input type="checkbox"/> Utility | 4. <input type="checkbox"/> Mercantile / Commercial |
| 5. <input type="checkbox"/> Industrial               | 6. <input type="checkbox"/> Government              | 7. <input type="checkbox"/> School  | 8. <input type="checkbox"/> Residential             |
| 9. <input type="checkbox"/> Agricultural             | 10. <input type="checkbox"/> Other (specify): _____ |                                     |   |

**C. TANK CONSTRUCTION (check one):**

|  |  |   |                                      |
|--|--|---|--------------------------------------|
| 1. <input type="checkbox"/> Bare Steel   | 2. <input type="checkbox"/> FRP Clad Steel | 3. <input type="checkbox"/> Steel With Lining | 4. <input type="checkbox"/> Concrete |
| 5. <input type="checkbox"/> Other (specify): _____   |  |   |                                      |
| Tank is built to: <input type="checkbox"/> National Standard _____ or <input type="checkbox"/> UL Approval or <input type="checkbox"/> Other _____ |  |   |                                      |

**D. ROOF (Check one):**

|  |   |   |   |
|--|---|---|---|
| 1. <input type="checkbox"/> Fixed Roof | 2. <input type="checkbox"/> Floating External | 3. <input type="checkbox"/> Floating Internal | 4. <input type="checkbox"/> Other _____ |
|--|---|---|---|

**E. TANK BASE:**

|  |   |                                       |                                      |
|--|---|---------------------------------------|--------------------------------------|
| 1. <input type="checkbox"/> On Ground  | 2. <input type="checkbox"/> On Supports | 3. <input type="checkbox"/> On Cement | 4. <input type="checkbox"/> On Liner |
| 5. <input type="checkbox"/> Double Bottom    6. <input type="checkbox"/> Other _____ |   |                                       |                                      |

**F. PIPING:**

|  |                                      |                               |
|--|--------------------------------------|-------------------------------|
| <input type="checkbox"/> Aboveground   | <input type="checkbox"/> Underground | <input type="checkbox"/> Both |
| Above Ground Piping Construction: <input type="checkbox"/> Steel <input type="checkbox"/> Other _____  |                                      |                               |
| Underground Piping Construction:   |                                      |                               |
| 1. <input type="checkbox"/> Bare Steel    2. <input type="checkbox"/> Cathodically Protected and coated or Wrapped Steel (a. <input type="checkbox"/> Sacrificial Anodes or b. <input type="checkbox"/> Impressed Current)    3. <input type="checkbox"/> Coated Steel |                                      |                               |
| 4. <input type="checkbox"/> Fiberglass    5. <input type="checkbox"/> Other (specify): _____    6. <input type="checkbox"/> Unknown  |                                      |                               |

**G. CONTAINMENT:**

Dike Side Material:    1.  Block    2.  Concrete    3.  Earth    4.  Synthetic

Dike Base Material:    1.  Concrete    2.  Engineered Clay - Thickness \_\_\_\_\_    3.  Earth    4.  Synthetic- Make & Model #: \_\_\_\_\_

Remote Impounding?     Yes     No

**H. DISTANCE FROM DIKE WALL TO NEAREST:**

1. Well \_\_\_\_\_ Ft.    2. Property Line \_\_\_\_\_ Ft.    3. Surface Water \_\_\_\_\_ Ft.    4. Nearest Building On Property \_\_\_\_\_ Ft.

**I. TANK CONTENTS**

|                                       |  |   |                                      |
|---------------------------------------|--|---|--------------------------------------|
| 1. <input type="checkbox"/> Diesel    | 2. <input type="checkbox"/> Leaded     | 3. <input type="checkbox"/> Unleaded    | 4. <input type="checkbox"/> Fuel Oil |
| 5. <input type="checkbox"/> Gasohol   | 6. <input type="checkbox"/> Other      | 7. <input type="checkbox"/> Empty       | 9. <input type="checkbox"/> Unknown  |
| 10. <input type="checkbox"/> Premix   | 11. <input type="checkbox"/> Waste Oil | 13. <input type="checkbox"/> Chemical * |                                      |
| 14. <input type="checkbox"/> Kerosene | 15. <input type="checkbox"/> Aviation  |   |                                      |

\* If # 13 is checked, indicate the chemical name(s) or number(s) of the chemical or waste.

|  |                    |              |
|--|--------------------|--------------|
| If Tank Was Removed or Cleaned For Other Use, Give Date (mo/day/yr): | Owner's Signature: | Date Signed: |
|--|--------------------|--------------|

# UNDERGROUND STORAGE TANK USE PERMIT APPLICATION

Send Completed Form To:  
Safety and Buildings Division  
Bureau of Petroleum Inspection  
and Fire Protection  
P.O. Box 7969, Madison, WI 53707

|                |
|----------------|
| Tank ID Number |
|----------------|

|  |                           |                              |                            |
|--|---------------------------|------------------------------|----------------------------|
| 1. Tank Leak Detection Compliance Date | 2. Tank Installation Date | 3. Gallons                   | 4. User                    |
| 5. Tank Construction                   | 6. Tank Double Walled?    | 7. Tank Overfill Protection: | 8. Tank Spill Containment: |
| 9. Tank Leak Detection Method          |                           |                              |                            |
| 10. Piping Construction                | 11. Piping Double Walled? | 12. Piping System Type       | 13. Piping Leak Detection  |
| 14. Tank Contents                      |                           |                              |                            |

|  |  |
|--|--|
|  |  |
|--|--|

If the site name and/or address appearing above is incorrect in any way, please indicate corrections below:

If the owner/mailling name and/or address appearing above is incorrect in any way, please indicate corrections below:

## TANK SYSTEM DESCRIPTION VERIFICATION

Wisconsin Administrative Code Chapter ILHR 10 requires a Use Permit to be obtained for the continued operation of the underground petroleum storage tank described on this application. It is necessary that you review and verify the pre-printed codes and descriptions appearing above in boxes 2 thru 14 that apply to the system identified here. **PLEASE NOTE: "TANK CONSTRUCTION" IN BOX 5, "PIPING CONSTRUCTION" IN BOX 10 AND "PIPING SYSTEM TYPE" IN BOX 12 MUST BE COMPLETED. IF THIS INFORMATION IS NOT PROVIDED, A USE PERMIT CANNOT BE ISSUED.** Make all applicable corrections using the code summary below. After your code and description review, indicate if system description is:

OK as printed above      or       OK with corrections/data completions.

Then see instructions below to complete the remaining portion of this application.

### CODE KEY

- Type of User:**            01-Gas Station; 02-Bulk Storage; 03-Utility; 04-Mercantile; 05-Industrial; 06-Government; 07-School; 08-Residential  
09-Agriculture; 10-Other
- Tank Construction;**    01-Bare Steel; 02-Cathodically Protected and Coated Steel (a.-Sacrificial Anodes or b.-Impressed Current); 03-Coated Steel;  
04-Fiberglass; 05-other; 06-Relined; 07-Steel - Fiberglass Reinforced Plastic Composite; 09-Unknown
- Tank Leak Detection Method:**    01-Automatic Tank Gauging; 02-Vapor Monitoring; 03-Groundwater Monitoring; 04-Inventory Control and Tightness;  
Testing 05-Interstitial Monitoring; 06-Not Required At Present 07-Manual Tank Gauging (only for tanks of 1,000 gallons or less)
- Piping Construction:**    01-Bare Steel; 02-Cathodically Protected and Coated or Wrapped Steel (a.-Sacrificial Anodes or b.-Impressed Current);  
03-Coated Steel; 04-Fiberglass; 05-other; 09-Unknown
- Piping System Type:**    01-Pressurized Piping With: a.-Auto Shutoff; b.-Alarm; or c.-Flow Restrictor; 02-Suction Piping With Check Valve at Tank;  
03-Suction Piping With Check Valve at Pump and Inspectable
- Piping Leak Detection Method:**    01-Vapor Monitoring; 02-Interstitial Monitoring; 03-Groundwater Monitoring; 04-Tightness Testing;  
05-Line Leak Detector; 06-Not Required
- Tank Contents:**            01-Diesel; 02-Leaded; 03-Unleaded; 04-Fuel Oil; 05-Gasohol; 06-Other; 07-Empty; 08-Sand/Gravel/Slurry; 09-Unknown;  
10-Premix; 11-Waste Oil; 12-Propane; 13-Chemical; 14-Kerosene; 15-Aviation

### INSTRUCTIONS FOR COMPLETION OF REVERSE SIDE

- If the "leak detection" compliance date indicated in box 1 above has been reached, Section A on the reverse side must be completed to verify compliance with leak detection code requirements.
- If box 12 above shows code 01 or if you have pressurized piping but had not previously indicated such, you must complete Section C to verify compliance with pressurized piping code requirements.
- If box 12 above shows code 02, or if you have a suction system with the check valve at the tank but previously had not reported it, the compliance date for leak detection on your piping is the same as that for the tank. If you have reached the tank leak detection compliance date indicated in box 1 above, you must complete Section C on the reverse side.

**A. Leak Detection Verification For Tank**

Indicate which leak detection method(s) you are using. Check all applicable items and attach requested information.

- Tightness testing and inventory control. Attach a copy of the report on the latest tank test.
- Vapor monitoring. Attach a plot plan drawn to scale (scale not smaller than 1" = 20') showing the location of tanks and associated monitoring wells. Provide the name and model number of the device used to monitor for presence of vapors: \_\_\_\_\_  
Name Model #
- Groundwater monitoring. Attach a plot plan drawn to scale (scale not smaller than 1" = 20') showing the location of tanks and associated monitoring wells. Provide depth to groundwater: \_\_\_\_\_ feet. Provide name and model number of device/system used to monitor for presence of product in well: \_\_\_\_\_  
Name Model #
- Interstitial Monitoring. Provide name and model number of interstitial monitoring device: \_\_\_\_\_  
Name Model #
- Automatic tank gauging. Provide name and model # of gauge system: \_\_\_\_\_  
Name Model #
- Manual tank gauging (tanks of 1,000 gallons or less in size only).

**B. Pressurized Piping Systems Must Have Leak Detection Installed By 12/22/90. System requires both:**

Flow restrictor, automatic shutoff or continuous alarm; provide the name and model number of system installed:

\_\_\_\_\_ Name Model #

**AND**

A leak detection method from the following list; check all items that apply and attach requested information.

- Tightness testing. Attach a copy of the report on the latest test of the piping system.
- Vapor monitoring. Attach a plot plan drawn to scale (scale not smaller than 1" = 20') showing the location of piping and associated monitoring wells. Provide the name and model number of the device used to monitor for presence of vapors: \_\_\_\_\_  
Name Model #
- Groundwater monitoring. Attach a plot plan drawn to scale (scale not smaller than 1" = 20') showing the location of piping and associated monitoring wells. Provide depth to groundwater: \_\_\_\_\_ feet. Provide name and model number of device/system used to monitor for presence of product in well: \_\_\_\_\_  
Name Model #
- Interstitial Monitoring. Provide name and model number of interstitial monitoring device: \_\_\_\_\_  
Name Model #
- Line leak detector. Provide name and model # of device: \_\_\_\_\_  
Name Model #

**C. Leak Detection For Piping**

Suction piping with the check valve at the tank: indicate which method(s) of leak detection you are using. Check all items that apply and attach requested information. Leak detection deadlines for suction piping (with the check valve at the tank) match that of the tank system.

- Tightness testing. Attach a copy of the report on the latest test of the system.
- Vapor monitoring. Attach a plot plan drawn to scale (scale not smaller than 1" = 20') showing the location of lines and associated monitoring wells. Provide the name and model number of the device used to monitor for presence of vapors: \_\_\_\_\_  
Name Model #
- Groundwater monitoring. Attach a plot plan drawn to scale (scale not smaller than 1" = 20') showing the location of piping and associated monitoring wells. Provide depth to groundwater: \_\_\_\_\_ feet. Provide name and model number of device/system used to monitor for presence of product in well: \_\_\_\_\_  
Name Model #
- Interstitial Monitoring. Provide name and model number of interstitial monitoring device: \_\_\_\_\_  
Name Model #

A10.15 ABANDONED OR REMOVED UNDERGROUND STORAGE TANK REGISTRATION PROCEDURE. The following forms (SBD-7437 and SBD-8731) are referred to in this section. Copies of this form are available from the Division of Safety and Buildings, P.O. Box 7969, Madison, Wisconsin 53707, or from the local fire department or authorized agent.



## UNDERGROUND PETROLEUM PRODUCT TANK INVENTORY

Send Completed Form To:  
Safety & Buildings Division  
P.O. Box 7969  
Madison, WI 53707  
Telephone (608) 267-5280

**For Office Use Only:**  
Tank ID # \_\_\_\_\_

This form is to be completed pursuant to Section 101.142, Wis. Stats., to register all underground tanks in Wisconsin that have stored or currently store petroleum or regulated substances. Please see the reverse side for additional information on this program. An underground storage tank is defined as any tank with at least 10 percent of its total volume (included piping) located below ground level. A separate form is needed for each tank. Send each completed form to the agency designated in the top right corner.

|   |  |   |  |
|---|--|---|--|
| This registration applies to a tank that is (check one):                  |  |   | Fire Department Providing Fire Coverage<br>Where Tank Located: |
| 1. <input type="checkbox"/> In Use or New                                 | 4. <input type="checkbox"/> Closed - Tank Removed                  | 8. <input type="checkbox"/> Changed Ownership<br>(Indicate new owner below) |  |
| 2. <input type="checkbox"/> Abandoned With Product                        | 6. <input type="checkbox"/> Closed - Filled With<br>Inert Material | 7. <input type="checkbox"/> Out of Service                                  |  |
| 3. <input type="checkbox"/> Abandoned No Product (empty)<br>or With Water |  |   |  |

**A. IDENTIFICATION: (Please Print)**

|   |                                  |  |       |   |                           |  |
|---|----------------------------------|--|-------|---|---------------------------|--|
| 1. Tank Site Name   |                                  | Site Mailing Address                   |       |   | Site Telephone No.<br>( ) |  |
| <input type="checkbox"/> City   | <input type="checkbox"/> Village | <input type="checkbox"/> Town of:      | State | Zip Code  | County                    |  |
| 2. Owner Name (mail sent here unless indicated otherwise in #3 below) |                                  |  |       | Owner Mailing Address (mail sent here unless indicated otherwise in #3) |                           |  |
| <input type="checkbox"/> City   | <input type="checkbox"/> Village | <input type="checkbox"/> Town of:      | State | Zip Code  | County                    |  |
| 3. Alternate Mailing Name If Different Than #2                        |                                  |  |       | Alternate Mailing Street Address If Different From #2                   |                           |  |
| <input type="checkbox"/> City   | <input type="checkbox"/> Village | <input type="checkbox"/> Town of:      | State | Zip Code  | County                    |  |
| 4. Tank Age (date installed, if known: or years old)                  | 5. Tank Capacity (gallons)       | 6. Tank Manufacturer's Name (if known) |       |   |                           |  |

**B. TYPE OF USER (check one):**

|  |   |                                     |   |
|--|---|-------------------------------------|---|
| 1. <input type="checkbox"/> Gas Station  | 2. <input type="checkbox"/> Bulk Storage            | 3. <input type="checkbox"/> Utility | 4. <input type="checkbox"/> Mercantile  |
| 5. <input type="checkbox"/> Industrial   | 6. <input type="checkbox"/> Government              | 7. <input type="checkbox"/> School  | 8. <input type="checkbox"/> Residential |
| 9. <input type="checkbox"/> Agricultural | 10. <input type="checkbox"/> Other (specify): _____ |                                     |   |

**C. TANK CONSTRUCTION:**

|  |   |  |   |
|--|---|--|---|
| 1. <input type="checkbox"/> Bare Steel   | 2. <input type="checkbox"/> Cathodically Protected and Coated Steel (A. <input type="checkbox"/> Sacrificial Anodes or B. <input type="checkbox"/> Impressed Current) |  |   |
| 3. <input type="checkbox"/> Coated Steel   | 4. <input type="checkbox"/> Fiberglass  | 5. <input type="checkbox"/> Other (specify): _____ |   |
| 6. <input type="checkbox"/> Relined  | 7. <input type="checkbox"/> Steel - Fiberglass Reinforced Plastic Composite   |  |   |
| 8. <input type="checkbox"/> Unknown  |   |  |   |
| Approval: 1. <input type="checkbox"/> Nat'l Std. 2. <input type="checkbox"/> UL 3. <input type="checkbox"/> Other:   |   |  | Is Tank Double Walled? <input type="checkbox"/> Yes <input type="checkbox"/> No |
| Overfill Protection Provided? <input type="checkbox"/> Yes <input type="checkbox"/> No If yes, identify type:  |   |  | Spill Containment? <input type="checkbox"/> Yes <input type="checkbox"/> No     |
| Tank leak detection method: 1. <input type="checkbox"/> Automatic tank gauging 2. <input type="checkbox"/> Vapor monitoring 3. <input type="checkbox"/> Groundwater monitoring 4. <input type="checkbox"/> Inventory control and tightness testing 5. <input type="checkbox"/> Interstitial monitoring 6. <input type="checkbox"/> Not required at present 7. <input type="checkbox"/> Manual Tank Gauging (only for tanks of 1,000 gallons or less) |   |  |   |

**D. PIPING CONSTRUCTION**

|   |  |  |   |
|---|--|--|---|
| 1. <input type="checkbox"/> Bare Steel  | 2. <input type="checkbox"/> Cathodically Protected and Coated or Wrapped Steel (A. <input type="checkbox"/> Sacrificial Anodes or B. <input type="checkbox"/> Impressed Current) |  | 3. <input type="checkbox"/> Coated Steel                                |
| 4. <input type="checkbox"/> Fiberglass  | 5. <input type="checkbox"/> Other (specify): _____   |  | 9. <input type="checkbox"/> Unknown                                     |
| Piping System Type: 1. <input type="checkbox"/> Pressurized piping with: A. <input type="checkbox"/> auto shutoff; B. <input type="checkbox"/> alarm; or C. <input type="checkbox"/> flow restrictor 2. <input type="checkbox"/> Suction piping with check valve at tank 3. <input type="checkbox"/> Suction piping with check valve at pump and inspectable        |  |  |   |
| Piping leak detection method: used if pressurized or check valve at tank: 1. <input type="checkbox"/> Vapor monitoring 2. <input type="checkbox"/> Interstitial monitoring 3. <input type="checkbox"/> Groundwater monitoring 4. <input type="checkbox"/> Tightness testing 5. <input type="checkbox"/> Line Leak Detector 6. <input type="checkbox"/> Not Required |  |  |   |
| Approval: 1. <input type="checkbox"/> Nat'l Std 2. <input type="checkbox"/> UL 3. <input type="checkbox"/> Other:   |  |  | Double Walled: <input type="checkbox"/> Yes <input type="checkbox"/> No |

**E. TANK CONTENTS**

|   |                                     |  |  |
|---|-------------------------------------|--|--|
| 1. <input type="checkbox"/> Diesel      | 2. <input type="checkbox"/> Leaded  | 3. <input type="checkbox"/> Unleaded   | 4. <input type="checkbox"/> Fuel Oil           |
| 5. <input type="checkbox"/> Gasohol     | 6. <input type="checkbox"/> Other   | 7. <input type="checkbox"/> Empty      | 8. <input type="checkbox"/> Sand/Gravel/Slurry |
| 9. <input type="checkbox"/> Unknown     | 10. <input type="checkbox"/> Premix | 11. <input type="checkbox"/> Waste Oil | 12. <input type="checkbox"/> Propane           |
| 13. <input type="checkbox"/> Chemical * |                                     | 14. <input type="checkbox"/> Kerosene  | 15. <input type="checkbox"/> Aviation          |

\* If # 13 is checked, indicate the chemical name(s) or number(s) of the chemical or waste.

|  |  |
|--|--|
| If Tank Closed, Give Date (mo/day/yr): | Has a site assessment been completed? (see reverse side for details)<br><input type="checkbox"/> Yes <input type="checkbox"/> No |
|--|--|

|  |                                   |  |
|--|-----------------------------------|--|
| If installation of a new tank is being reported, indicate who performed the installation inspection: |                                   |  |
| 1. <input type="checkbox"/> Fire Department  | 2. <input type="checkbox"/> DILHR | 3. <input type="checkbox"/> Other (identify) _____ |

|   |  |
|---|--|
| Name of Owner or Operator (please print): | Indicate Whether:<br><input type="checkbox"/> Owner or <input type="checkbox"/> Operator |
| Signature of Owner or Operator:           | Date Signed:   |

**IMPORTANT:** Complete as many items on this form as possible. Failure to provide sufficient information may cause you to fall under additional regulations.

## BACKGROUND FOR TANK INVENTORY

On May 4, 1984, legislation commonly known as the Ground Water Protection Act was signed into law. This legislation required the creation of an inventory of underground petroleum product storage tanks. A record of this information was necessitated by numerous reported incidents of ground water contamination by petroleum products. Many tanks have been installed, used and forgotten. These installations can threaten the ground water.

This underground tank inventory is being established to help identify the need for future actions required to clear up potential problems before they occur. Your help in identifying abandoned, "in use" and "new use" tank locations will greatly assist this effort to protect Wisconsin's ground water.

### SITE ASSESSMENT INFORMATION

Requirements for a site assessment at the closure or change in service for a federally regulated underground storage tank were outlined in federal rules published in the September 23, 1988 Federal Register, 40 CFR 280 and 281.

The requirements in § 280.72 state:

(a) Before permanent closure or a change-in-service is completed, owners and operators must measure for the presence of a release where contamination is most likely to be present at the UST site. In selecting sample types, sample locations, and measurement methods, owners and operators must consider the method of closure, the nature of the stored substance, the type of backfill, the depth to ground water, and other factors appropriate for identifying the presence of a release. The requirements of this section are satisfied if one of the external release detection methods allowed in § 280.43 (e) and (f) is operating in accordance with the requirements in § 280.43 at the time of closure, and indicates no release has occurred.

The external release detection methods in § 280.43 (e) and (f) are summarized below:

*"(e) Vapor monitoring."* This sub section refers to the testing or monitoring for vapors within the soil gas of the tank's excavation zone. It further requires seven (7) conditions to be met to qualify the testing program as a valid vapor monitoring system.

*"(f) Ground-water monitoring."* This sub section refers to the testing or monitoring for liquids on the ground water below the tank. It establishes the requirements for an acceptable system that effectively monitors the ground water for the presence of regulated substances and insures the integrity of the monitoring wells so the wells themselves do not become conduits for ground water contamination.

Complete written guidelines on the conduct of a site assessment can be obtained from the DILHR Bureau of Petroleum Inspection & Fire Protection at the following address:

Bureau of Petroleum Inspection and Fire Protection  
P.O. Box 7969  
Madison, WI 53707

Site assessments are to be submitted to both the DILHR office and to the DNR at the following addresses:

Bureau of Petroleum Inspection & Fire Protection  
P.O. Box 7969  
Madison, WI 53707

Bureau of Solid and Hazardous Waste Management  
P.O. Box 7921  
Madison, WI 53707

**ABOVEGROUND  
PETROLEUM PRODUCT  
TANK INVENTORY**

Safety & Buildings Division  
P.O. Box 7969  
Madison, WI 53707  
Telephone (608) 267-5280

For Office Use Only:  
Tank ID #

This form must be completed pursuant to s. 101.142, Wis. Stats., to register an above ground petroleum product storage system. An aboveground petroleum product storage system is an **aboveground** tank, used to store petroleum products, together with an on-site integral piping or dispensing system. **Not included** are pipeline facilities, tanks of 110 gallons or less capacity, farm and residential tanks of 1,100 gallons or less capacity, tanks used for storing heating oil for consumptive use on the premises where stored or tanks owned by the state or federal government. **A separate form is needed for each tank. Send each completed form to the address in the top right corner.**

This registration applies to a tank that is (check one):

|  |   |  |
|--|---|--|
| 1. <input type="checkbox"/> In Use                                 | 4. <input type="checkbox"/> Closed - Tank Removed   | Fire Department Providing Fire Coverage Where Tank Is Located:<br><input type="checkbox"/> City <input type="checkbox"/> Village <input type="checkbox"/> Town of: _____ |
| 2. <input type="checkbox"/> Out of Service With Product            | 5. <input type="checkbox"/> Closed - Tank Cleaned   |  |
| 3. <input type="checkbox"/> Out of Service With No Product (Empty) | 6. <input type="checkbox"/> Changed Ownership (Indicate new owner in section A. 3. below) |  |

**A. IDENTIFICATION (Please Print)**

|   |   |  |
|---|---|--|
| 1. Tank Site Name   | Site Mailing Address  | Site Telephone Number<br>(    )        |
| <input type="checkbox"/> City <input type="checkbox"/> Village <input type="checkbox"/> Town of:  | State   | Zip Code    County                     |
| 2. Owner Name (mail sent here unless indicated otherwise in #3)   | Owner Mailing Address (mail sent here unless indicated otherwise in #3) |  |
| <input type="checkbox"/> City <input type="checkbox"/> Village <input type="checkbox"/> Town of:  | State   | Zip Code    County                     |
| 3. Alternate Mailing Name If Different Than #2  | Alternate Mailing Street Address If Different Than #2                   |  |
| <input type="checkbox"/> City <input type="checkbox"/> Village <input type="checkbox"/> Town of:  | State   | Zip Code    County                     |
| 4. Tank Age (date installed, if new; years old, if used)  | 5. Tank Capacity (gal.)   | 6. Tank Manufacturer's Name (if known) |
| 7. If more than 1 tank is being reported at a facility, provide an 8 1/2 x 11 plot plan drawn to scale (1" = 20 ft.), numbering and indicating the location of the tanks being reported. If a plot plan is being submitted, this form is for tank number: |   |  |

**B. TYPE OF USER (check one):**

|  |   |                                     |   |
|--|---|-------------------------------------|---|
| 1. <input type="checkbox"/> Gas Station (any resale) | 2. <input type="checkbox"/> Bulk Storage            | 3. <input type="checkbox"/> Utility | 4. <input type="checkbox"/> Mercantile / Commercial |
| 5. <input type="checkbox"/> Industrial               | 6. <input type="checkbox"/> Government              | 7. <input type="checkbox"/> School  | 8. <input type="checkbox"/> Residential             |
| 9. <input type="checkbox"/> Agricultural             | 10. <input type="checkbox"/> Other (specify): _____ |                                     |   |

**C. TANK CONSTRUCTION (check one):**

|  |  |   |                                      |
|--|--|---|--------------------------------------|
| 1. <input type="checkbox"/> Bare Steel             | 2. <input type="checkbox"/> FRP Clad Steel | 3. <input type="checkbox"/> Steel With Lining | 4. <input type="checkbox"/> Concrete |
| 5. <input type="checkbox"/> Other (specify): _____ |  |   |                                      |

Tank is built to:  National Standard \_\_\_\_\_ or  UL Approval or  Other \_\_\_\_\_

**D. ROOF (Check one):**

|  |   |   |   |
|--|---|---|---|
| 1. <input type="checkbox"/> Fixed Roof | 2. <input type="checkbox"/> Floating External | 3. <input type="checkbox"/> Floating Internal | 4. <input type="checkbox"/> Other _____ |
|--|---|---|---|

**E. TANK BASE:**

|   |   |                                       |                                      |
|---|---|---------------------------------------|--------------------------------------|
| 1. <input type="checkbox"/> On Ground     | 2. <input type="checkbox"/> On Supports | 3. <input type="checkbox"/> On Cement | 4. <input type="checkbox"/> On Liner |
| 5. <input type="checkbox"/> Double Bottom | 6. <input type="checkbox"/> Other _____ |                                       |                                      |

**F. PIPING:**

|   |  |  |
|---|--|--|
| <input type="checkbox"/> Aboveground  | <input type="checkbox"/> Underground   | <input type="checkbox"/> Both            |
| Above Ground Piping Construction: <input type="checkbox"/> Steel <input type="checkbox"/> Other _____ |  |  |
| Underground Piping Construction:  |  |  |
| 1. <input type="checkbox"/> Bare Steel  | 2. <input type="checkbox"/> Cathodically Protected and coated or Wrapped Steel (a. <input type="checkbox"/> Sacrificial Anodes or b. <input type="checkbox"/> Impressed Current) | 3. <input type="checkbox"/> Coated Steel |
| 4. <input type="checkbox"/> Fiberglass  | 5. <input type="checkbox"/> Other (specify): _____   | 6. <input type="checkbox"/> Unknown      |

**G. CONTAINMENT:**

Dike Side Material: 1.  Block    2.  Concrete    3.  Earth    4.  Synthetic

Dike Base Material: 1.  Concrete    2.  Engineered Clay - Thickness \_\_\_\_\_    3.  Earth    4.  Synthetic-Make & Model #:

Remote Impounding?  Yes  No

**H. DISTANCE FROM DIKE WALL TO NEAREST:**

1. Well \_\_\_\_\_ Ft.    2. Property Line \_\_\_\_\_ Ft.    3. Surface Water \_\_\_\_\_ Ft.    4. Nearest Building On Property \_\_\_\_\_ Ft.

**I. TANK CONTENTS**

|                                       |  |   |                                      |
|---------------------------------------|--|---|--------------------------------------|
| 1. <input type="checkbox"/> Diesel    | 2. <input type="checkbox"/> Leaded     | 3. <input type="checkbox"/> Unleaded          | 4. <input type="checkbox"/> Fuel Oil |
| 5. <input type="checkbox"/> Gasohol   | 6. <input type="checkbox"/> Other      | 7. <input type="checkbox"/> Empty             | 9. <input type="checkbox"/> Unknown  |
| 10. <input type="checkbox"/> Premix   | 11. <input type="checkbox"/> Waste Oil | 13. <input type="checkbox"/> Chemical * _____ |                                      |
| 14. <input type="checkbox"/> Kerosene | 15. <input type="checkbox"/> Aviation  |   |                                      |

\* If # 13 is checked, indicate the chemical name(s) or number(s) of the chemical or waste.

|  |                    |              |
|--|--------------------|--------------|
| If Tank Was Removed or Cleaned For Other Use, Give Date (mo/day/yr): | Owner's Signature: | Date Signed: |
|--|--------------------|--------------|

A10.16 NEW AND REPLACEMENT UNDERGROUND TANK USE PERMIT. The following forms (SBD-7658 and SBD-7659) are referred to in this section. Copies of these forms are available from the Division of Safety and Buildings, P.O. Box 7969, Madison, Wisconsin 53707, or from the local fire department or authorized agent.

# UNDERGROUND STORAGE TANK USE PERMIT APPLICATION

Send Completed Form To:  
Safety and Buildings Division  
Bureau of Petroleum Inspection  
and Fire Protection  
P.O. Box 7969, Madison, WI 53707

|                |
|----------------|
| Tank ID Number |
|----------------|

|  |                           |                              |                            |                               |
|--|---------------------------|------------------------------|----------------------------|-------------------------------|
| 1. Tank Leak Detection Compliance Date | 2. Tank Installation Date | 3. Gallons                   | 4. User                    |                               |
| 5. Tank Construction                   | 6. Tank Double Walled?    | 7. Tank Overfill Protection: | 8. Tank Spill Containment: | 9. Tank Leak Detection Method |
| 10. Piping Construction                | 11. Piping Double Walled? | 12. Piping System Type       | 13. Piping Leak Detection  | 14. Tank Contents             |

|  |  |
|--|--|
|  |  |
|--|--|

If the site name and/or address appearing above is incorrect in any way, please indicate corrections below:

If the owner/mailling name and/or address appearing above is incorrect in any way, please indicate corrections below:

## TANK SYSTEM DESCRIPTION VERIFICATION

Wisconsin Administrative Code Chapter ILHR 10 requires a Use Permit to be obtained for the continued operation of the underground petroleum storage tank described on this application. It is necessary that you review and verify the pre-printed codes and descriptions appearing above in boxes 2 thru 14 that apply to the system identified here. **PLEASE NOTE: "TANK CONSTRUCTION" IN BOX 5, "PIPING CONSTRUCTION" IN BOX 10 AND "PIPING SYSTEM TYPE" IN BOX 12 MUST BE COMPLETED. IF THIS INFORMATION IS NOT PROVIDED, A USE PERMIT CANNOT BE ISSUED.** Make all applicable corrections using the code summary below. After your code and description review, indicate if system description is:

OK as printed above      or       OK with corrections/data completions.

Then see instructions below to complete the remaining portion of this application.

### CODE KEY

- Type of User:**            01-Gas Station; 02-Bulk Storage; 03-Utility; 04-Mercantile; 05-Industrial; 06-Government; 07-School; 08-Residential  
09-Agriculture; 10-Other
- Tank Construction;**    01-Bare Steel; 02-Cathodically Protected and Coated Steel (a.-Sacrificial Anodes or b.-Impressed Current); 03-Coated Steel;  
04-Fiberglass; 05-other; 06-Relined; 07-Steel - Fiberglass Reinforced Plastic Composite; 09-Unknown
- Tank Leak Detection Method:**    01-Automatic Tank Gauging; 02-Vapor Monitoring; 03-Groundwater Monitoring; 04-Inventory Control and Tightness;  
Testing 05-Interstitial Monitoring; 06-Not Required At Present 07-Manual Tank Gauging (only for tanks of 1,000 gallons or less)
- Piping Construction:**    01-Bare Steel; 02-Cathodically Protected and Coated or Wrapped Steel (a.-Sacrificial Anodes or b.-Impressed Current);  
03-Coated Steel; 04-Fiberglass; 05-other; 09-Unknown
- Piping System Type:**    01-Pressurized Piping With: a.-Auto Shutoff; b.-Alarm; or c.-Flow Restrictor; 02-Suction Piping With Check Valve at Tank;  
03-Suction Piping With Check Valve at Pump and Inspectable
- Piping Leak Detection Method:**    01-Vapor Monitoring; 02-Interstitial Monitoring; 03-Groundwater Monitoring; 04-Tightness Testing;  
05-Line Leak Detector; 06-Not Required
- Tank Contents:**            01-Diesel; 02-Leaded; 03-Unleaded; 04-Fuel Oil; 05-Gasohol; 06-Other; 07-Empty; 08-Sand/Gravel/Slurry; 09-Unknown;  
10-Premix; 11-Waste Oil; 12-Propane; 13-Chemical; 14-Kerosene; 15-Aviation

### INSTRUCTIONS FOR COMPLETION OF REVERSE SIDE

- If the "leak detection" compliance date indicated in box 1 above has been reached, Section A on the reverse side must be completed to verify compliance with leak detection code requirements.
- If box 12 above shows code 01 or if you have pressurized piping but had not previously indicated such, you must complete Section C to verify compliance with pressurized piping code requirements.
- If box 12 above shows code 02, or if you have a suction system with the check valve at the tank but previously had not reported it, the compliance date for leak detection on your piping is the same as that for the tank. If you have reached the tank leak detection compliance date indicated in box 1 above, you must complete Section C on the reverse side.

**A. Leak Detection Verification For Tank**

Indicate which leak detection method(s) you are using. Check all applicable items and attach requested information .

- Tightness testing and inventory control. Attach a copy of the report on the latest tank test.
- Vapor monitoring. Attach a plot plan drawn to scale (scale not smaller than 1" = 20') showing the location of tanks and associated monitoring wells. Provide the name and model number of the device used to monitor for presence of vapors: \_\_\_\_\_  
Name Model #
- Groundwater monitoring. Attach a plot plan drawn to scale (scale not smaller than 1" = 20') showing the location of tanks and associated monitoring wells. Provide depth to groundwater: \_\_\_\_\_ feet. Provide name and model number of device/system used to monitor for presence of product in well: \_\_\_\_\_  
Name Model #
- Interstitial Monitoring. Provide name and model number of interstitial monitoring device: \_\_\_\_\_  
Name Model #
- Automatic tank gauging. Provide name and model # of gauge system: \_\_\_\_\_  
Name Model #
- Manual tank gauging (tanks of 1,000 gallons or less in size only).

**B. Pressurized Piping Systems Must Have Leak Detection Installed By 12/22/90. System requires both:**

Flow restrictor, automatic shutoff or continuous alarm; provide the name and model number of system installed:

\_\_\_\_\_ Name Model #

**AND**

A leak detection method from the following list; check all items that apply and attach requested information.

- Tightness testing. Attach a copy of the report on the latest test of the piping system.
- Vapor monitoring. Attach a plot plan drawn to scale (scale not smaller than 1" = 20') showing the location of piping and associated monitoring wells. Provide the name and model number of the device used to monitor for presence of vapors: \_\_\_\_\_  
Name Model #
- Groundwater monitoring. Attach a plot plan drawn to scale (scale not smaller than 1" = 20') showing the location of piping and associated monitoring wells. Provide depth to groundwater: \_\_\_\_\_ feet. Provide name and model number of device/system used to monitor for presence of product in well: \_\_\_\_\_  
Name Model #
- Interstitial Monitoring. Provide name and model number of interstitial monitoring device: \_\_\_\_\_  
Name Model #
- Line leak detector. Provide name and model # of device: \_\_\_\_\_  
Name Model #

**C. Leak Detection For Piping**

Suction piping with the check valve at the tank: indicate which method(s) of leak detection you are using. Check all items that apply and attach requested information. Leak detection deadlines for suction piping (with the check valve at the tank) match that of the tank system.

- Tightness testing. Attach a copy of the report on the latest test of the system.
- Vapor monitoring. Attach a plot plan drawn to scale (scale not smaller than 1" = 20') showing the location of lines and associated monitoring wells. Provide the name and model number of the device used to monitor for presence of vapors: \_\_\_\_\_  
Name Model #
- Groundwater monitoring. Attach a plot plan drawn to scale (scale not smaller than 1" = 20') showing the location of piping and associated monitoring wells. Provide depth to groundwater: \_\_\_\_\_ feet. Provide name and model number of device/system used to monitor for presence of product in well: \_\_\_\_\_  
Name Model #
- Interstitial Monitoring. Provide name and model number of interstitial monitoring device: \_\_\_\_\_  
Name Model #

**UNDERGROUND STORAGE TANK  
USE PERMIT**

**THIS PERMIT MUST BE KEPT ON SITE  
AVAILABLE FOR INSPECTION AT ALL TIMES**

This tank has met the requirements of Wisconsin Administrative Code Chapter ILHR 10. The three year use period has been approved with the issuance of this Use Permit. This permit may be revoked for failure to maintain compliance with the requirements of ILHR 10.

|                  |                      |                       |                            |                           |                        |                    |
|------------------|----------------------|-----------------------|----------------------------|---------------------------|------------------------|--------------------|
| Tank ID Number:  | Permit Effective On: | Permit Expires As Of: | Tank Installation Date:    | Gallons:                  | User:                  | Tank Construction: |
| Mailing Address: |                      |                       | Tank Double Walled:        | Tank Overfill Protection: | Tank Spill Containment |                    |
|                  |                      |                       | Tank Leak Detection:       | Piping Construction:      | Piping Double Walled:  |                    |
|                  |                      |                       | Piping System Type:        | Piping Leak Detection     | Tank Contents:         |                    |
|                  |                      |                       | Permitted Tank Located At: |                           |                        |                    |

SBD-7659 (N: 01/91)

**CODE KEY**

- Type of User:** 01-Gas Station; 02-Bulk Storage; 03-Utility; 04-Mercantile; 05-Industrial; 06-Government; 07-School; 08-Residential  
09-Agriculture; 10-Other
- Tank Construction:** 01-Bare Steel; 02-Cathodically Protected and Coated Steel (a.-Sacrificial Anodes or b.-Impressed Current); 03-Coated Steel;  
04-Fiberglass; 05-other; 06-Relined; 07-Steel - Fiberglass Reinforced Plastic Composite; 09-Unknown
- Tank Leak Detection Method:** 01-Automatic Tank Gauging; 02-Vapor Monitoring; 03-Groundwater Monitoring; 04-Inventory Control and  
Tightness Testing; 05-Interstitial Monitoring; 06-Not Required At Present 07-Manual Tank Gauging (only for  
tanks of 1,000 gallons or less)
- Piping Construction:** 01-Bare Steel; 02-Cathodically Protected and Coated or Wrapped Steel (a.-Sacrificial Anodes or b.-Impressed Current);  
03-Coated Steel; 04-Fiberglass; 05-other; 09-Unknown
- Piping System Type:** 01-Pressurized Piping With: a.-Auto Shutoff; b.-Alarm; or c.-Flow Restrictor; 02-Suction Piping With Check Valve at Tank;  
03-Suction Piping With Check Valve at Pump and Inspectable
- Piping Leak Detection Method:** 01-Vapor Monitoring; 02-Interstitial Monitoring; 03-Groundwater Monitoring; 04-Tightness Testing;  
05-Line Leak Detector; 06-Not Required
- Tank Contents:** 01-Diesel; 02-Leaded; 03-Unleaded; 04-Fuel Oil; 05-Gasohol; 06-Other; 07-Empty; 08-Sand/Gravel/Slurry; 09-Unknown;  
10-Premix; 11-Waste Oil; 13-Chemical; 14-Kerosene; 15-Aviation

A10.17 EXISTING UNDERGROUND TANK USE PERMIT. The following forms (SBD-7658, SBD-7659 and SBD-6294) are referred to in this section. Copies of these forms are available from the Division of Safety and Buildings, P.O. Box 7969, Madison, Wisconsin 53707, or from the local fire department or authorized agent.



# UNDERGROUND STORAGE TANK USE PERMIT APPLICATION

Send Completed Form To:  
Safety and Buildings Division  
Bureau of Petroleum Inspection  
and Fire Protection  
P.O. Box 7969, Madison, WI 53707

Tank ID Number \_\_\_\_\_

|  |                           |                              |                            |
|--|---------------------------|------------------------------|----------------------------|
| 1. Tank Leak Detection Compliance Date | 2. Tank Installation Date | 3. Gallons                   | 4. User                    |
| 5. Tank Construction                   | 6. Tank Double Walled?    | 7. Tank Overfill Protection: | 8. Tank Spill Containment: |
| 9. Tank Leak Detection Method          |                           |                              |                            |
| 10. Piping Construction                | 11. Piping Double Walled? | 12. Piping System Type       | 13. Piping Leak Detection  |
|  |                           | 14. Tank Contents            |                            |

If the site name and/or address appearing above is incorrect in any way, please indicate corrections below:

If the owner/mailling name and/or address appearing above is incorrect in any way, please indicate corrections below:

## TANK SYSTEM DESCRIPTION VERIFICATION

Wisconsin Administrative Code Chapter ILHR 10 requires a Use Permit to be obtained for the continued operation of the underground petroleum storage tank described on this application. It is necessary that you review and verify the pre-printed codes and descriptions appearing above in boxes 2 thru 14 that apply to the system identified here. **PLEASE NOTE: "TANK CONSTRUCTION" IN BOX 5, "PIPING CONSTRUCTION" IN BOX 10 AND "PIPING SYSTEM TYPE" IN BOX 12 MUST BE COMPLETED. IF THIS INFORMATION IS NOT PROVIDED, A USE PERMIT CANNOT BE ISSUED.** Make all applicable corrections using the code summary below. After your code and description review, indicate if system description is:

OK as printed above      or       OK with corrections/data completions.

Then see instructions below to complete the remaining portion of this application.

### CODE KEY

- Type of User:**            01-Gas Station; 02-Bulk Storage; 03-Utility; 04-Mercantile; 05-Industrial; 06-Government; 07-School; 08-Residential  
09-Agriculture; 10-Other
- Tank Construction;**    01-Bare Steel; 02-Cathodically Protected and Coated Steel (a.-Sacrificial Anodes or b.-Impressed Current); 03-Coated Steel;  
04-Fiberglass; 05-other; 06-Relined; 07-Steel - Fiberglass Reinforced Plastic Composite; 09-Unknown
- Tank Leak Detection Method:**    01-Automatic Tank Gauging; 02-Vapor Monitoring; 03-Groundwater Monitoring; 04-Inventory Control and Tightness;  
Testing 05-Interstitial Monitoring; 06-Not Required At Present 07-Manual Tank Gauging (only for tanks of 1,000 gallons or less)
- Piping Construction:**    01-Bare Steel; 02-Cathodically Protected and Coated or Wrapped Steel (a.-Sacrificial Anodes or b.-Impressed Current);  
03-Coated Steel; 04-Fiberglass; 05-other; 09-Unknown
- Piping System Type:**    01-Pressurized Piping With: a.-Auto Shutoff; b.-Alarm; or c.-Flow Restrictor; 02-Suction Piping With Check Valve at Tank;  
03-Suction Piping With Check Valve at Pump and Inspectable
- Piping Leak Detection Method:**    01-Vapor Monitoring; 02-Interstitial Monitoring; 03-Groundwater Monitoring; 04-Tightness Testing;  
05-Line Leak Detector; 06-Not Required
- Tank Contents:**            01-Diesel; 02-Leaded; 03-Unleaded; 04-Fuel Oil; 05-Gasohol; 06-Other; 07-Empty; 08-Sand/Gravel/Slurry; 09-Unknown;  
10-Premix; 11-Waste Oil; 12-Propane; 13-Chemical; 14-Kerosene; 15-Aviation

### INSTRUCTIONS FOR COMPLETION OF REVERSE SIDE

- If the "leak detection" compliance date indicated in box 1 above has been reached, Section A on the reverse side must be completed to verify compliance with leak detection code requirements.
- If box 12 above shows code 01 or if you have pressurized piping but had not previously indicated such, you must complete Section C to verify compliance with pressurized piping code requirements.
- If box 12 above shows code 02, or if you have a suction system with the check valve at the tank but previously had not reported it, the compliance date for leak detection on your piping is the same as that for the tank. If you have reached the tank leak detection compliance date indicated in box 1 above, you must complete Section C on the reverse side.

**A. Leak Detection Verification For Tank**

Indicate which leak detection method(s) you are using. Check all applicable items and attach requested information.

- Tightness testing and inventory control. Attach a copy of the report on the latest tank test.
- Vapor monitoring. Attach a plot plan drawn to scale (scale not smaller than 1" = 20') showing the location of tanks and associated monitoring wells. Provide the name and model number of the device used to monitor for presence of vapors: \_\_\_\_\_  
Name Model #
- Groundwater monitoring. Attach a plot plan drawn to scale (scale not smaller than 1" = 20') showing the location of tanks and associated monitoring wells. Provide depth to groundwater: \_\_\_\_\_ feet. Provide name and model number of device/system used to monitor for presence of product in well: \_\_\_\_\_  
Name Model #
- Interstitial Monitoring. Provide name and model number of interstitial monitoring device: \_\_\_\_\_  
Name Model #
- Automatic tank gauging. Provide name and model # of gauge system: \_\_\_\_\_  
Name Model #
- Manual tank gauging (tanks of 1,000 gallons or less in size only).

**B. Pressurized Piping Systems Must Have Leak Detection Installed By 12/22/90. System requires both:**

Flow restrictor, automatic shutoff or continuous alarm; provide the name and model number of system installed:

\_\_\_\_\_ Name Model #

**AND**

A leak detection method from the following list; check all items that apply and attach requested information.

- Tightness testing. Attach a copy of the report on the latest test of the piping system.
- Vapor monitoring. Attach a plot plan drawn to scale (scale not smaller than 1" = 20') showing the location of piping and associated monitoring wells. Provide the name and model number of the device used to monitor for presence of vapors: \_\_\_\_\_  
Name Model #
- Groundwater monitoring. Attach a plot plan drawn to scale (scale not smaller than 1" = 20') showing the location of piping and associated monitoring wells. Provide depth to groundwater: \_\_\_\_\_ feet. Provide name and model number of device/system used to monitor for presence of product in well: \_\_\_\_\_  
Name Model #
- Interstitial Monitoring. Provide name and model number of interstitial monitoring device: \_\_\_\_\_  
Name Model #
- Line leak detector. Provide name and model # of device: \_\_\_\_\_  
Name Model #

**C. Leak Detection For Piping**

Suction piping with the check valve at the tank: indicate which method(s) of leak detection you are using. Check all items that apply and attach requested information. Leak detection deadlines for suction piping (with the check valve at the tank) match that of the tank system.

- Tightness testing. Attach a copy of the report on the latest test of the system.
- Vapor monitoring. Attach a plot plan drawn to scale (scale not smaller than 1" = 20') showing the location of lines and associated monitoring wells. Provide the name and model number of the device used to monitor for presence of vapors: \_\_\_\_\_  
Name Model #
- Groundwater monitoring. Attach a plot plan drawn to scale (scale not smaller than 1" = 20') showing the location of piping and associated monitoring wells. Provide depth to groundwater: \_\_\_\_\_ feet. Provide name and model number of device/system used to monitor for presence of product in well: \_\_\_\_\_  
Name Model #
- Interstitial Monitoring. Provide name and model number of interstitial monitoring device: \_\_\_\_\_  
Name Model #

**UNDERGROUND STORAGE TANK  
USE PERMIT**

**THIS PERMIT MUST BE KEPT ON SITE  
AVAILABLE FOR INSPECTION AT ALL TIMES**

This tank has met the requirements of Wisconsin Administrative Code Chapter ILHR 10. The three year use period has been approved with the issuance of this Use Permit. This permit may be revoked for failure to maintain compliance with the requirements of ILHR 10.

|                  |                      |                       |                            |                           |                        |                    |
|------------------|----------------------|-----------------------|----------------------------|---------------------------|------------------------|--------------------|
| Tank ID Number:  | Permit Effective On: | Permit Expires As Of: | Tank Installation Date:    | Gallons:                  | User:                  | Tank Construction: |
| Mailing Address: |                      |                       | Tank Double Walled:        | Tank Overfill Protection: | Tank Spill Containment |                    |
|                  |                      |                       | Tank Leak Detection:       | Piping Construction:      | Piping Double Walled:  |                    |
|                  |                      |                       | Piping System Type:        | Piping Leak Detection     | Tank Contents:         |                    |
|                  |                      |                       | Permitted Tank Located At: |                           |                        |                    |

SBD-7659 (N. 01/91)

**CODE KEY**

- Type of User:** 01-Gas Station; 02-Bulk Storage; 03-Utility; 04-Mercantile; 05-Industrial; 06-Government; 07-School; 08-Residential  
09-Agriculture; 10-Other
- Tank Construction:** 01-Bare Steel; 02-Cathodically Protected and Coated Steel (a.-Sacrificial Anodes or b.-Impressed Current); 03-Coated Steel;  
04-Fiberglass; 05-other; 06-Relined; 07-Steel - Fiberglass Reinforced Plastic Composite; 09-Unknown
- Tank Leak Detection Method:** 01-Automatic Tank Gauging; 02-Vapor Monitoring; 03-Groundwater Monitoring; 04-Inventory Control and  
Tightness Testing; 05-Interstitial Monitoring; 06-Not Required At Present 07-Manual Tank Gauging (only for  
tanks of 1,000 gallons or less)
- Piping Construction:** 01-Bare Steel; 02-Cathodically Protected and Coated or Wrapped Steel (a.-Sacrificial Anodes or b.-Impressed Current);  
03-Coated Steel; 04-Fiberglass; 05-other; 09-Unknown
- Piping System Type:** 01-Pressurized Piping With: a.-Auto Shutoff; b.-Alarm; or c.-Flow Restrictor; 02-Suction Piping With Check Valve at Tank;  
03-Suction Piping With Check Valve at Pump and Inspectable
- Piping Leak Detection Method:** 01-Vapor Monitoring; 02-Interstitial Monitoring; 03-Groundwater Monitoring; 04-Tightness Testing;  
05-Line Leak Detector; 06-Not Required
- Tank Contents:** 01-Diesel; 02-Leaded; 03-Unleaded; 04-Fuel Oil; 05-Gasohol; 06-Other; 07-Empty; 08-Sand/Gravel/Slurry; 09-Unknown;  
10-Premix; 11-Waste Oil; 13-Chemical; 14-Kerosene; 15-Aviation

**CHECKLIST FOR UNDERGROUND  
TANK INSTALLATION**

Tank ID #: For Office Use Only

**Complete one form for each  
tank and related piping.**

**A. IDENTIFICATION: (Please Print)**

|   |                                  |                                   |                                     |                                   |                                   |                             |          |
|---|----------------------------------|-----------------------------------|-------------------------------------|-----------------------------------|-----------------------------------|-----------------------------|----------|
| 1. Installation Name                      |                                  |                                   | 2. Owner Name                       |                                   |                                   |                             |          |
| Installation Street Address               |                                  |                                   | Owner Street Address                |                                   |                                   |                             |          |
| <input type="checkbox"/> City             | <input type="checkbox"/> Village | <input type="checkbox"/> Town of: | <input type="checkbox"/> City       | <input type="checkbox"/> Village  | <input type="checkbox"/> Town of: | State                       | Zip Code |
| State                                     | Zip Code                         | County                            | County                              | Telephone No. (include area code) |                                   |                             | ( )      |
| 3. Installation Company Name              |                                  |                                   | Installation Company Street Address |                                   |                                   | State                       | Zip Code |
| Company Telephone No. (include area code) |                                  |                                   | Certified Installer Name            |                                   |                                   | Installer Certification No. |          |
| ( )                                       |                                  |                                   |                                     |                                   |                                   |                             |          |

This checklist covers installation of:  Tank;  Piping;  Spill Containment;  Overfill Prot.;  Leak Dect.

**B. PLAN APPROVAL**

| INSTALLER<br>VERIFIED | INSPECTOR<br>VERIFIED | NA |
|-----------------------|-----------------------|----|
|-----------------------|-----------------------|----|

- Plans have been submitted and approved. (Tanks 5000 gallons or larger individual capacity require DILHR approval. Tanks under 5000 gallons capacity require local approval.)
- State plan number (if applicable) is \_\_\_\_\_
- Tank Capacity: \_\_\_\_\_ gallons. Tank contents, if known: \_\_\_\_\_

**C. TANK CONSTRUCTION**

- Tank is new and carries UL or other national testing label.
- Tank does not have a UL label but manufacturer has provided a statement that the tank is constructed in accordance with UL specifications or other national standard.
- Tank is used, but has been recertified to meet the EPA new tank standard.
- Tank is corrosion protected (  Cathodically protected steel,  fiberglass or  composite tank) and matches the equipment listed in the plan review.
- Test stations have been installed for monitoring cathodic protection on the tank.
- Gasoline and other Class I flammable tank vents discharge at least 12 feet above ground level, discharge only upward, and do not terminate under eaves or near a building opening.
- Fuel oil, diesel or other Class II or III A liquid storage tank vents are at least 3 feet above ground level.
- Overfill protection device is installed and matches plan submittal.
- Spill containment device installed.

**D. TANK HANDLING AND TESTING**

- Tank was lifted using lifting lugs, no chains or slings were placed around the tank shell.
- Tank coating was inspected and any damage to the coating repaired.
- Preinstallation test of single wall tank conducted by pressurizing tank with 3-5 psig air pressure, soaping all surfaces, seams, and fittings and inspecting for bubbles.
- or  
Preinstallation test of double-walled tank: pressurize inner tank to a maximum of 5 psig, seal inner tank and disconnect external air supply, monitor for one hour. After one hour, pressurize the interstitial space with a max 5 psig air from the inner tank and use a second gauge for monitoring the pressure. Soap all surfaces, seams and fittings and inspect for bubbles.
- Tank tested after backfilling through precision test, approved tank gauge or interstitial monitor.
- Tank gauge or interstitial monitor verified as operative

**E. TANK SITE AND BACKFILL**

- Tank located a minimum of 3 feet from property lines and 1 foot from buildings.
- Tank is spaced a minimum of 2 feet from any other tank.
- Backfill for steel or fiberglass clad steel tank is clean, washed, well granulated sand, crushed rock, or pea gravel no larger than 3/4 inch.
- Backfill for fiberglass tank is pea gravel naturally round with minimum diameter of 1/8 inch and maximum size of 3/4 inch or crushed rock or gravel between 1/8 and 1/2 inch in size.
- Minimum of 1 foot of backfill extended beyond perimeter of tank.
- Minimum of 1 foot of compacted backfill in bottom of excavation (If hold down pads are used, bedding may be reduced to 6 inches.)
- Bottom hold down pads used.
- a. Fiberglass tank with 1 foot of compacted backfill over top of pad.
- b. Steel tank with 6 inches of compacted backfill over top of pad.
- Backfill material placed over tank to a depth of at least 1 foot.

|   | INSTALLER<br>VERIFIED    | INSPECTOR<br>VERIFIED    | NA                       |
|---|--------------------------|--------------------------|--------------------------|
| <b>E. TANK SITE AND BACKFILL (continued)</b>  |                          |                          |                          |
| 9. Backfill compaction is adequate to securely and evenly support the tank and prevent movement/settlement.   | <input type="checkbox"/> | <input type="checkbox"/> | <input type="checkbox"/> |
| 10. Excavation is in a bog, swampy area or landfill and a filter fabric was used to prevent the migration of the backfill material.                   | <input type="checkbox"/> | <input type="checkbox"/> | <input type="checkbox"/> |
| 11. Tank in area of vehicle traffic, 3 feet of earth cover or 18 inches of earth plus 6 inches of reinforced concrete or 8 inches of asphalt.         | <input type="checkbox"/> | <input type="checkbox"/> | <input type="checkbox"/> |
| 12. Tank in area not subject to traffic, a minimum of 2 feet of earth or 1 foot of earth plus 4 inches of reinforced concrete or 6 inches of asphalt. | <input type="checkbox"/> | <input type="checkbox"/> | <input type="checkbox"/> |

|  |                          |                          |                          |
|--|--------------------------|--------------------------|--------------------------|
| <b>F. TANK ANCHORAGE</b>   |                          |                          |                          |
| 1. Installation is in an area of high water table or subject to flooding and tank is anchored.   | <input type="checkbox"/> | <input type="checkbox"/> | <input type="checkbox"/> |
| a. Anchor straps for fiberglass tank were nonmetallic and were placed according to manufacturer's specifications.  | <input type="checkbox"/> | <input type="checkbox"/> | <input type="checkbox"/> |
| b. Anchor straps for steel tank were either nonmetallic or electrically isolated from the tank structure. (All metal fittings are protected from corrosion.) | <input type="checkbox"/> | <input type="checkbox"/> | <input type="checkbox"/> |
| c. Mid anchoring with non conductive material between tank and concrete.   | <input type="checkbox"/> | <input type="checkbox"/> | <input type="checkbox"/> |

|  |                          |                          |                          |
|--|--------------------------|--------------------------|--------------------------|
| <b>G. PIPING (Indicate whether piping is <input type="checkbox"/> Fiberglass or <input type="checkbox"/> Steel; then check one of the types below before proceeding to answer 1 - 15.)</b>   |                          |                          |                          |
| <input type="checkbox"/> Pressurized piping with <input type="checkbox"/> auto shutoff, <input type="checkbox"/> alarm or <input type="checkbox"/> flow restrictor   |                          |                          |                          |
| <input type="checkbox"/> Suction piping with check valve at tank   |                          |                          |                          |
| <input type="checkbox"/> Suction piping with check valve at pump and inspectable.  |                          |                          |                          |
| 1. Piping is sloped back to tank (1/8 INCH per foot).  | <input type="checkbox"/> | <input type="checkbox"/> | <input type="checkbox"/> |
| 2. Piping is evenly and adequately supported by at least 6 inches of backfill bedding.   | <input type="checkbox"/> | <input type="checkbox"/> | <input type="checkbox"/> |
| 3. Piping trench provides at least 18 inches of compacted backfill and paving on top of piping.  | <input type="checkbox"/> | <input type="checkbox"/> | <input type="checkbox"/> |
| 4. Pipes are separated by at least twice the pipe diameter.  | <input type="checkbox"/> | <input type="checkbox"/> | <input type="checkbox"/> |
| 5. Pipes are separated from the trench excavation sidewalls by at least 6 inches.  | <input type="checkbox"/> | <input type="checkbox"/> | <input type="checkbox"/> |
| 6. Piping inspected for damage to pipe or coating.   | <input type="checkbox"/> | <input type="checkbox"/> | <input type="checkbox"/> |
| 7. Metal piping is at least schedule 40 black steel or galvanized pipe, and is wrapped or coated.  | <input type="checkbox"/> | <input type="checkbox"/> | <input type="checkbox"/> |
| 8. Fittings and couplings are extra-heavy malleable iron screw-type, Schedule 40 or better.  | <input type="checkbox"/> | <input type="checkbox"/> | <input type="checkbox"/> |
| 9. Piping was isolated from the tank and dispenser and tested at 150% of operating pressure of the system (but not less than 50 psi) for 1 hour prior to and after backfilling.  | <input type="checkbox"/> | <input type="checkbox"/> | <input type="checkbox"/> |
| 10. After backfilling, piping was isolated from the tank and dispenser and precision tested at 110% of operating pressure but not less than 50 psig for 1 hour.  | <input type="checkbox"/> | <input type="checkbox"/> | <input type="checkbox"/> |
| 11. Piping was isolated from the tank and dispenser and tested through another approved means prior to and after backfilling. Indicate method(s) prior _____ after _____   | <input type="checkbox"/> | <input type="checkbox"/> | <input type="checkbox"/> |
| 12. Metal piping is protected from corrosion by <input type="checkbox"/> cathodic protection or <input type="checkbox"/> impressed current.  | <input type="checkbox"/> | <input type="checkbox"/> | <input type="checkbox"/> |
| 13. Test stations have been installed for monitoring cathodic protection on piping.  | <input type="checkbox"/> | <input type="checkbox"/> | <input type="checkbox"/> |
| 14. Swing joints or flexible connectors are used at the beginning and end of each product, vent, and vapor recovery line and also where lines change direction (metallic piping) or if less than 4 feet of run exists between changes in direction with fiberglass piping. | <input type="checkbox"/> | <input type="checkbox"/> | <input type="checkbox"/> |
| 15. Dispensers, pumps, check valves, etc., not cathodically protected are electrically isolated from metallic piping.  | <input type="checkbox"/> | <input type="checkbox"/> | <input type="checkbox"/> |

|  |  |
|--|--|
| <b>H. LEAK DETECTION (Check which applies under both TANK and PIPING)</b>  |  |
| 1. Tank  |  |
| <input type="checkbox"/> Tightness testing and inventory control <input type="checkbox"/> Automatic tank gauging <input type="checkbox"/> Vapor monitoring <input type="checkbox"/> Groundwater monitoring |  |
| <input type="checkbox"/> Interstitial monitoring <input type="checkbox"/> Manual Tank Gauging (only for tanks of 1,000 gallons or less)  |  |
| 2. Piping (pressurized or suction with check valve at tank)  |  |
| <input type="checkbox"/> Tightness testing <input type="checkbox"/> Automatic line leak detectors <input type="checkbox"/> Vapor monitoring  |  |
| <input type="checkbox"/> Groundwater monitoring <input type="checkbox"/> Interstitial monitoring   |  |

**I. INSPECTOR INFORMATION (Inspector signature/number and covering jurisdiction/FDID number)**

Inspector Signature: \_\_\_\_\_ Inspector #: \_\_\_\_\_ Date Signed: \_\_\_\_\_

Fire department providing coverage: \_\_\_\_\_ FDID #: \_\_\_\_\_

**J. INSTALLER CERTIFICATION**

I certify that the tank and related piping was installed according to the manufacturer's instructions and comply with one of the following standards:  API 1615,  PEI RP100 or  ANSI B31.4.

Installer Signature \_\_\_\_\_ Date Signed \_\_\_\_\_

**TANK INVENTORY FORM SBD-7437 SIGNED BY THE OWNER MUST BE SUBMITTED WITH EACH INSTALLMENT CHECKLIST.**

A10.18 (2) INSPECTION BEFORE COVERING. The following checklist (Form SBD-6294) is provided to assist fire department inspectors or authorized agents in making inspections of underground storage tank installations before covering.

**CHECKLIST FOR UNDERGROUND  
TANK INSTALLATION**

Tank ID #: For Office Use Only

**Complete one form for each  
tank and related piping.**

**A. IDENTIFICATION: (Please Print)**

|  |                                  |                                   |                                     |  |                                  |                                   |          |          |
|--|----------------------------------|-----------------------------------|-------------------------------------|--|----------------------------------|-----------------------------------|----------|----------|
| 1. Installation Name                             |                                  |                                   |                                     | 2. Owner Name                            |                                  |                                   |          |          |
| Installation Street Address                      |                                  |                                   |                                     | Owner Street Address                     |                                  |                                   |          |          |
| <input type="checkbox"/> City                    | <input type="checkbox"/> Village | <input type="checkbox"/> Town of: |                                     | <input type="checkbox"/> City            | <input type="checkbox"/> Village | <input type="checkbox"/> Town of: | State    | Zip Code |
| State  | Zip Code                         | County                            | County                              | Telephone No. (include area code)<br>( ) |                                  |                                   |          |          |
| 3. Installation Company Name                     |                                  |                                   | Installation Company Street Address |  |                                  | State                             | Zip Code |          |
| Company Telephone No. (include area code)<br>( ) |                                  |                                   | Certified Installer Name            |  |                                  | Installer Certification No.       |          |          |

This checklist covers installation of:  Tank;  Piping;  Spill Containment;  Overfill Prot.;  Leak Dect.

**B. PLAN APPROVAL**

- |   | INSTALLER<br>VERIFIED    | INSPECTOR<br>VERIFIED    | NA                       |
|---|--------------------------|--------------------------|--------------------------|
| 1. Plans have been submitted and approved. (Tanks 5000 gallons or larger individual capacity require DILHR approval. Tanks under 5000 gallons capacity require local approval.) | <input type="checkbox"/> | <input type="checkbox"/> | <input type="checkbox"/> |
| 2. State plan number (if applicable) is _____   |                          |                          |                          |
| 3. Tank Capacity: _____ gallons. Tank contents, if known: _____   |                          |                          |                          |

**C. TANK CONSTRUCTION**

- |  |                          |                          |                          |
|--|--------------------------|--------------------------|--------------------------|
| 1. Tank is new and carries UL or other national testing label.   | <input type="checkbox"/> | <input type="checkbox"/> | <input type="checkbox"/> |
| 2. Tank does not have a UL label but manufacturer has provided a statement that the tank is constructed in accordance with UL specifications or other national standard.   | <input type="checkbox"/> | <input type="checkbox"/> | <input type="checkbox"/> |
| 3. Tank is used, but has been recertified to meet the EPA new tank standard.   | <input type="checkbox"/> | <input type="checkbox"/> | <input type="checkbox"/> |
| 4. Tank is corrosion protected ( <input type="checkbox"/> Cathodically protected steel, <input type="checkbox"/> fiberglass or <input type="checkbox"/> composite tank) and matches the equipment listed in the plan review. | <input type="checkbox"/> | <input type="checkbox"/> | <input type="checkbox"/> |
| 5. Test stations have been installed for monitoring cathodic protection on the tank.   | <input type="checkbox"/> | <input type="checkbox"/> | <input type="checkbox"/> |
| 6. Gasoline and other Class I flammable tank vents discharge at least 12 feet above ground level, discharge only upward, and do not terminate under eaves or near a building opening.  | <input type="checkbox"/> | <input type="checkbox"/> | <input type="checkbox"/> |
| 7. Fuel oil, diesel or other Class II or III A liquid storage tank vents are at least 3 feet above ground level.   | <input type="checkbox"/> | <input type="checkbox"/> | <input type="checkbox"/> |
| 8. Overfill protection device is installed and matches plan submittal.   | <input type="checkbox"/> | <input type="checkbox"/> | <input type="checkbox"/> |
| 9. Spill containment device installed.   | <input type="checkbox"/> | <input type="checkbox"/> | <input type="checkbox"/> |

**D. TANK HANDLING AND TESTING**

- |  |                          |                          |                          |
|--|--------------------------|--------------------------|--------------------------|
| 1. Tank was lifted using lifting lugs, no chains or slings were placed around the tank shell.  | <input type="checkbox"/> | <input type="checkbox"/> | <input type="checkbox"/> |
| 2. Tank coating was inspected and any damage to the coating repaired.  | <input type="checkbox"/> | <input type="checkbox"/> | <input type="checkbox"/> |
| 3. Preinstallation test of single wall tank conducted by pressurizing tank with 3-5 psig air pressure, soaping all surfaces, seams, and fittings and inspecting for bubbles.   | <input type="checkbox"/> | <input type="checkbox"/> | <input type="checkbox"/> |
| or   |                          |                          |                          |
| Preinstallation test of double-walled tank: pressurize inner tank to a maximum of 5 psig, seal inner tank and disconnect external air supply, monitor for one hour. After one hour, pressurize the interstitial space with a max 5 psig air from the inner tank and use a second gauge for monitoring the pressure. Soap all surfaces, seams and fittings and inspect for bubbles. | <input type="checkbox"/> | <input type="checkbox"/> | <input type="checkbox"/> |
| 4. Tank tested after backfilling through precision test, approved tank gauge or interstitial monitor.  | <input type="checkbox"/> | <input type="checkbox"/> | <input type="checkbox"/> |
| 5. Tank gauge or interstitial monitor verified as operative  | <input type="checkbox"/> | <input type="checkbox"/> | <input type="checkbox"/> |

**E. TANK SITE AND BACKFILL**

- |  |                          |                          |                          |
|--|--------------------------|--------------------------|--------------------------|
| 1. Tank located a minimum of 3 feet from property lines and 1 foot from buildings.   | <input type="checkbox"/> | <input type="checkbox"/> | <input type="checkbox"/> |
| 2. Tank is spaced a minimum of 2 feet from any other tank.   | <input type="checkbox"/> | <input type="checkbox"/> | <input type="checkbox"/> |
| 3. Backfill for steel or fiberglass clad steel tank is clean, washed, well granulated sand, crushed rock, or pea gravel no larger than 3/4 inch.   | <input type="checkbox"/> | <input type="checkbox"/> | <input type="checkbox"/> |
| 4. Backfill for fiberglass tank is pea gravel naturally round with minimum diameter of 1/8 inch and maximum size of 3/4 inch or crushed rock or gravel between 1/8 and 1/2 inch in size. | <input type="checkbox"/> | <input type="checkbox"/> | <input type="checkbox"/> |
| 5. Minimum of 1 foot of backfill extended beyond perimeter of tank.  | <input type="checkbox"/> | <input type="checkbox"/> | <input type="checkbox"/> |
| 6. Minimum of 1 foot of compacted backfill in bottom of excavation (If hold down pads are used, bedding may be reduced to 6 inches.)   | <input type="checkbox"/> | <input type="checkbox"/> | <input type="checkbox"/> |
| 7. Bottom hold down pads used.   | <input type="checkbox"/> | <input type="checkbox"/> | <input type="checkbox"/> |
| a. Fiberglass tank with 1 foot of compacted backfill over top of pad.  | <input type="checkbox"/> | <input type="checkbox"/> | <input type="checkbox"/> |
| b. Steel tank with 6 inches of compacted backfill over top of pad.   | <input type="checkbox"/> | <input type="checkbox"/> | <input type="checkbox"/> |
| 8. Backfill material placed over tank to a depth of at least 1 foot.   | <input type="checkbox"/> | <input type="checkbox"/> | <input type="checkbox"/> |

**E. TANK SITE AND BACKFILL (continued)**

|   | INSTALLER<br>VERIFIED    | INSPECTOR<br>VERIFIED    | NA                       |
|---|--------------------------|--------------------------|--------------------------|
| 9. Backfill compaction is adequate to securely and evenly support the tank and prevent movement/settlement.   | <input type="checkbox"/> | <input type="checkbox"/> | <input type="checkbox"/> |
| 10. Excavation is in a bog, swampy area or landfill and a filter fabric was used to prevent the migration of the backfill material.                   | <input type="checkbox"/> | <input type="checkbox"/> | <input type="checkbox"/> |
| 11. Tank in area of vehicle traffic, 3 feet of earth cover or 18 inches of earth plus 6 inches of reinforced concrete or 8 inches of asphalt.         | <input type="checkbox"/> | <input type="checkbox"/> | <input type="checkbox"/> |
| 12. Tank in area not subject to traffic, a minimum of 2 feet of earth or 1 foot of earth plus 4 inches of reinforced concrete or 6 inches of asphalt. | <input type="checkbox"/> | <input type="checkbox"/> | <input type="checkbox"/> |

**F. TANK ANCHORAGE**

|  |                          |                          |                          |
|--|--------------------------|--------------------------|--------------------------|
| 1. Installation is in an area of high water table or subject to flooding and tank is anchored.   | <input type="checkbox"/> | <input type="checkbox"/> | <input type="checkbox"/> |
| a. Anchor straps for fiberglass tank were nonmetallic and were placed according to manufacturer's specifications.  | <input type="checkbox"/> | <input type="checkbox"/> | <input type="checkbox"/> |
| b. Anchor straps for steel tank were either nonmetallic or electrically isolated from the tank structure. (All metal fittings are protected from corrosion.) | <input type="checkbox"/> | <input type="checkbox"/> | <input type="checkbox"/> |
| c. Mid anchoring with non conductive material between tank and concrete.   | <input type="checkbox"/> | <input type="checkbox"/> | <input type="checkbox"/> |

**G. PIPING (Indicate whether piping is  Fiberglass or  Steel; then check one of the types below before proceeding to answer 1 - 15.)**

- Pressurized piping with  auto shutoff,  alarm or  flow restrictor
- Suction piping with check valve at tank
- Suction piping with check valve at pump and inspectable.

|  |                          |                          |                          |
|--|--------------------------|--------------------------|--------------------------|
| 1. Piping is sloped back to tank (1/8 INCH per foot).  | <input type="checkbox"/> | <input type="checkbox"/> | <input type="checkbox"/> |
| 2. Piping is evenly and adequately supported by at least 6 inches of backfill bedding.   | <input type="checkbox"/> | <input type="checkbox"/> | <input type="checkbox"/> |
| 3. Piping trench provides at least 18 inches of compacted backfill and paving on top of piping.  | <input type="checkbox"/> | <input type="checkbox"/> | <input type="checkbox"/> |
| 4. Pipes are separated by at least twice the pipe diameter.  | <input type="checkbox"/> | <input type="checkbox"/> | <input type="checkbox"/> |
| 5. Pipes are separated from the trench excavation sidewalls by at least 6 inches.  | <input type="checkbox"/> | <input type="checkbox"/> | <input type="checkbox"/> |
| 6. Piping inspected for damage to pipe or coating.   | <input type="checkbox"/> | <input type="checkbox"/> | <input type="checkbox"/> |
| 7. Metal piping is at least schedule 40 black steel or galvanized pipe, and is wrapped or coated.  | <input type="checkbox"/> | <input type="checkbox"/> | <input type="checkbox"/> |
| 8. Fittings and couplings are extra-heavy malleable iron screw-type, Schedule 40 or better.  | <input type="checkbox"/> | <input type="checkbox"/> | <input type="checkbox"/> |
| 9. Piping was isolated from the tank and dispenser and tested at 150% of operating pressure of the system (but not less than 50 psi) for 1 hour prior to and after backfilling.  | <input type="checkbox"/> | <input type="checkbox"/> | <input type="checkbox"/> |
| 10. After backfilling, piping was isolated from the tank and dispenser and precision tested at 110% of operating pressure but not less than 50 psig for 1 hour.  | <input type="checkbox"/> | <input type="checkbox"/> | <input type="checkbox"/> |
| 11. Piping was isolated from the tank and dispenser and tested through another approved means prior to and after backfilling. Indicate method(s) prior _____ after _____   | <input type="checkbox"/> | <input type="checkbox"/> | <input type="checkbox"/> |
| 12. Metal piping is protected from corrosion by <input type="checkbox"/> cathodic protection or <input type="checkbox"/> impressed current.  | <input type="checkbox"/> | <input type="checkbox"/> | <input type="checkbox"/> |
| 13. Test stations have been installed for monitoring cathodic protection on piping.  | <input type="checkbox"/> | <input type="checkbox"/> | <input type="checkbox"/> |
| 14. Swing joints or flexible connectors are used at the beginning and end of each product, vent, and vapor recovery line and also where lines change direction (metallic piping) or if less than 4 feet of run exists between changes in direction with fiberglass piping. | <input type="checkbox"/> | <input type="checkbox"/> | <input type="checkbox"/> |
| 15. Dispensers, pumps, check valves, etc., not cathodically protected are electrically isolated from metallic piping.  | <input type="checkbox"/> | <input type="checkbox"/> | <input type="checkbox"/> |

**H. LEAK DETECTION (Check which applies under both TANK and PIPING)**

1. Tank
- Tightness testing and inventory control
  - Automatic tank gauging
  - Vapor monitoring
  - Groundwater monitoring
  - Interstitial monitoring
  - Manual Tank Gauging (only for tanks of 1,000 gallons or less)
2. Piping (pressurized or suction with check valve at tank)
- Tightness testing
  - Automatic line leak detectors
  - Vapor monitoring
  - Groundwater monitoring
  - Interstitial monitoring

**I. INSPECTOR INFORMATION (Inspector signature/number and covering jurisdiction/FDID number)**

Inspector Signature: \_\_\_\_\_ Inspector #: \_\_\_\_\_ Date Signed: \_\_\_\_\_

Fire department providing coverage: \_\_\_\_\_ FDID #: \_\_\_\_\_

**J. INSTALLER CERTIFICATION**

I certify that the tank and related piping was installed according to the manufacturer's instructions and comply with one of the following standards:  API 1615,  PEI RP100 or  ANSI B31.4.

Installer Signature \_\_\_\_\_ Date Signed \_\_\_\_\_



A10.22 PETITIONS FOR VARIANCE. The following forms (SB-8 and SB8A) are referred to in this section. Copies of these forms are available from the Division of Safety and Buildings, P.O. Box 7969, Madison, Wisconsin 53707, or from the local fire department or authorized agent.

**PETITION FOR VARIANCE APPLICATION**

Wisconsin Department of Industry, Labor and Human Relations  
 Safety and Buildings Division  
 201 East Washington Avenue, P.O. Box 7969  
 Madison, Wisconsin 53707  
 608/266-3151

|                        |  |
|------------------------|--|
| <b>OFFICE USE ONLY</b> |  |
| Amount Paid            |  |
| Receipt No.            |  |

|                        |  |
|------------------------|--|
| <b>OFFICE USE ONLY</b> |  |
| Petition No.           |  |
| E-Number               |  |

|                          |                           |                                      |
|--------------------------|---------------------------|--------------------------------------|
| Name of Owner/Petitioner | Building or Project       | Agent, Architect or Engineering Firm |
| Company                  | Tenant Name, if any       | Street & Number                      |
| Street & Number          | Location, Street & Number | City State Zip Code                  |
| City State Zip Code      | City County               | Telephone Number                     |
| Telephone Number         | Plan Number, if known     | Name of Contact Person               |

1. The rule being petitioned reads as follows: (cite specific rule number and language)

---



---



---

2. The rule being petitioned cannot be entirely satisfied because:

---



---



---

3. The following alternative(s) and supporting information are proposed as a means of providing an equivalent degree of health, safety or welfare as addressed by the rule:

---



---



---



---



---



---



---



---

Note: Please attach any pictures, plans, sketches or required position statements.

**VERIFICATION BY OWNER – PETITION IS VALID ONLY IF NOTARIZED AND ACCOMPANIED BY REVIEW FEE**

See Section Ind 69.15 for complete fee information

Note: Petitioner must be the owner of the building or project. Tenants, agents, designers, contractors, attorneys, etc. may not sign petition unless a Power of Attorney is submitted with the Petition for Variance Application.

\_\_\_\_\_, being duly sworn, I state as petitioner that I have read the foregoing (NAME OF PETITIONER, Please type/print) petition, that I believe it to be true and I have significant ownership rights in the subject building or project.

\_\_\_\_\_  
 Signature of Petitioner

Subscribed and sworn to before me this date: \_\_\_\_\_

\_\_\_\_\_  
 Notary Public

My commission expires: \_\_\_\_\_

**POSITION STATEMENT:**

To be compiled by  
Chief of Fire Department

**WISCONSIN DEPARTMENT OF  
INDUSTRY, LABOR AND HUMAN RELATIONS  
DIVISION OF SAFETY & BUILDINGS  
P.O. BOX 7969 MADISON WI 53707**

|                  |                                 |                                      |
|------------------|---------------------------------|--------------------------------------|
| Name of Owner    | Building Occupancy or Use       | Agent, Architect or Engineering Firm |
| Company          | Tenant Name, if any             | Street & No.                         |
| Street & No.     | Building Location, Street & No. | City State & Zip                     |
| City State & Zip | City County                     | Phone                                |

1. I have read the petition for variance of rule:

|   |        |          |                      |              |
|---|--------|----------|----------------------|--------------|
| 2. I recommend<br>(Check appropriate box) | Denial | Approval | Conditional Approval | No Comment * |
|---|--------|----------|----------------------|--------------|

3. Explanation for Recommendation:

\* If desired, Fire Departments may indicate "No Comment" on non-fire safety issues such as sanitary, energy conservation, structural, barrier free environments, etc.

4.  I find no conflict with local rules and regulations  
 I find that the petition is in conflict with local rules and regulations

Explanation

Signature of Fire Chief

Date

**PLEASE COMPLETE AND SUBMIT PROMPTLY TO DEPARTMENT OF INDUSTRY, LABOR AND HUMAN RELATIONS AT THE ADDRESS SHOWN ABOVE.**

A10.42 (3) (1) DISPENSING INTO MARINE CRAFT. The following illustration depicts a sign meeting the requirements of this section:

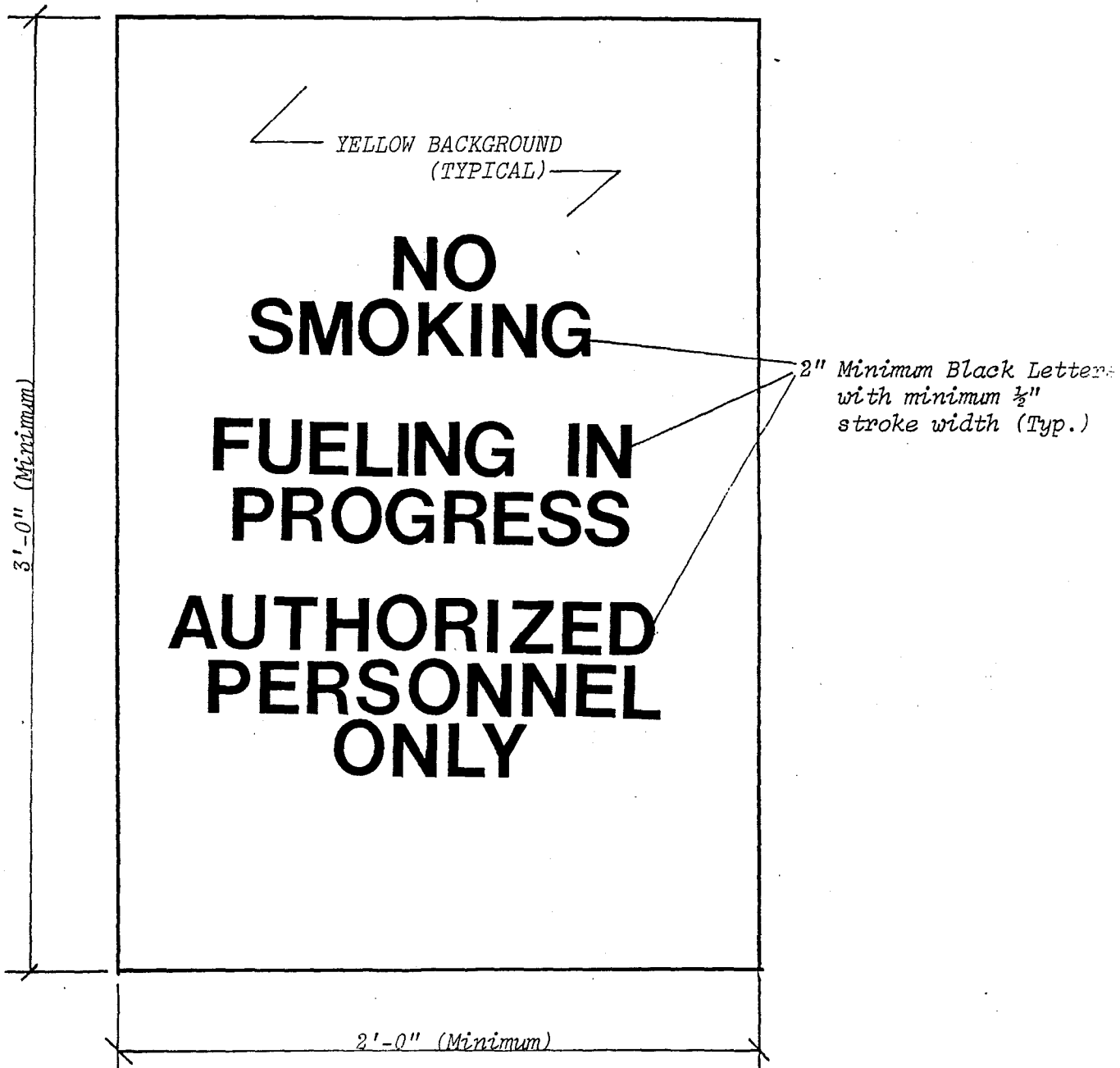

NOTE: The sign is drawn to scale.

## APPENDIX B

### CLOSURE ASSESSMENTS FOR UNDERGROUND STORAGE TANKS

#### I. Introduction

##### A. Purpose of the Closure Assessment:

The purpose of the closure assessment is to determine if contamination exists around an underground storage tank system. The assessment is to be carried out during the closure of federally regulated underground storage tanks (USTs) and/or piping or before a change-in-service.

Use of the procedures specified in this appendix will be acceptable to DILHR as compliance with the site assessment requirements of s. ILHR 10.734.

If contamination is discovered during the closure assessment, additional sampling or cleanup may be required by the Department of Natural Resources (DNR).

This guideline contains a number of attachments. These documents are designed, primarily, to provide information to the contractors or environmental consultants hired by the tank owner.

Before the closure of chemical tank systems, the DNR District Hazardous Waste Specialist must be contacted to determine if any special procedures or precautions must be taken.

##### B. Responsibilities During UST Closure Assessment:

The responsibilities that must be carried out during a tank closure are summarized below. The remainder of this document provides additional detail on these responsibilities. Although a contractor or environmental consultant may complete a number of the responsibilities, the owner is ultimately responsible for the successful completion of the closure assessment.

1. Notify the local fire chief, fire inspector or other DILHR authorized agent at least 15 days prior to closing the UST or piping.
2. Close the tank system in accordance with Attachment 1.
3. Complete and submit a "Tank Inventory Form", (SBD-7437) for each tank.

4. Complete the sampling, analysis, and documentation requirements for closure assessments (Section IV - VIII).
5. Report immediately any spills, leaks or contaminations from the tank or piping to the Division of Emergency Government Hot line (608) 266-3232 or to the DNR (Section VII).
6. Manage all tank residues including remaining product, accumulations of sludge, contaminated water, etc. in accordance with DNR and DILHR requirements. (A fact sheet on sludge management is included as Attachment 4. A fact sheet on the management of remaining petroleum product is included as Attachment 5.)
7. Send a copy of the closure assessment report to DILHR and a copy to the DNR (Section IX). Include a duplicate copy of the (SBD-7437) inventory form(s) which was submitted at closure.

## II. Applicability

Site assessments must be performed whenever they are required by ch. ILHR 10. Use of these closure assessment procedures will be acceptable to DILHR for performance of a site assessment.

## III. Preassessment Steps

### A. Notify the Local Authority That has Jurisdiction:

You must notify in writing the local DILHR authorized agent at least 30 days in advance of beginning the UST system closure/closure assessment. (A shorter notification period may be allowed by the local authorized agent.)

Note: Always check for local ordinances which may govern tank closures. DILHR's rules are minimum standards and local ordinances may be more restrictive.

At the time of notification, you should check with the local authorized agent to determine if he or she is willing to serve as a "neutral third party" during the assessment.

### B. Arrange for a Neutral Third Party:

It is extremely helpful if a local DILHR authorized agent or a staff member from the DNR acts as a neutral third party at the closure and closure assessment. Thirty days in advance of the closure, it should be determined if a neutral third party will observe the closure and complete a closure checklist.

Copies of a closure checklist will be available from DILHR.

C. Develop a Closure Assessment Plan:

The closure assessment must follow a written plan which addresses the items listed in Sections IV to VI. The plan must be available at the site during the assessment for reference and inspection by the fire chief or local authority having jurisdiction.

Note: The responsibility for developing and following the plans listed in 1 - 3 below belongs to the owner or to the contractor, consultant, or individual acting as the owner's agent. The plans do not have to be submitted as part of the closure assessment report.

1. A Field Procedures Plan which addresses each item from Section IV through VI.

2. A Tank Cleaning and Tank Waste Management Plan including the following elements:

a. Methods to be used to inert/vent and clean the tank that comply with ch. ILHR 10.

b. A plan for managing oil, gasoline, sludge, accumulated water or other tank contents. This plan must be in compliance with DNR solid and hazardous waste rules. Guidelines for managing tank wastes are available from DILHR or DNR.

Note: Specifications for tank removal may be found in API Standard 1604, NFPA 327 or other equivalent standards may be used.

c. A plan for transporting tanks which are to be removed from the ground and description of the final disposal point of the tank.

Note: The plan should include methods for protecting the safety and health of employees as addressed in Section 1910--OSHA regulations.

3. A Contingency Plan for Managing Contaminated Soils and Contaminated Excavation Water.

The contaminated soils and excavation water management plan must meet minimum requirements established by the DNR.

IV. Sample Collection Requirements

A. Who can collect soil samples?

Persons collecting soil samples must be certified by DILHR for such work or under the supervision of a certified person.

B. Reporting of sampling qualifications

1. Proof of certification of persons responsible for collecting soil samples should be included in the closure assessment report as a standard attachment.

Closure assessment reports based upon samples collected by uncertified individuals will not be accepted by the DNR.

C. Soil Sample Locations:

1. Collect samples in the native soil, not in the backfill material around the tank. Samples must be collected from all of the following locations:
  - a. At points where strong odors or soil discolorations indicate the presence of contamination.
  - b. In native soil 1 to 3 feet beneath the bottom of each end of each tank in the excavation.
  - c. In the native soil 1 to 3 feet beneath the surface underneath each island on the supply side.
  - d. In native soil 1 to 3 feet beneath the surface every 20 feet, or segment thereof, along piping runs. In meeting this requirement, samples should preferentially be taken under swing joints, flex connectors, or pipe elbows.

Note: A minimum two samples along the piping are required--one at the island and one along the piping run.

- e. If a remote fill pipe is present, in native soil 5 feet beneath the fill opening.
- f. When tanks are to be closed in place, soil sampling must still be performed. This may be accomplished by:

(1) Soil borings through the use of a drill rig. The borings must be located as close as possible (less than 3 feet) from each end of each tank. Soil borings along piping runs and pump islands must be located immediately adjacent to these structures. The borings must be completed, documented and abandoned in compliance with the requirements of NR 141.

(2) If the tank(s) can be safely entered, and holes can be cut in the bottom, the soil beneath the tank(s) may be sampled through the holes. The holes must be located near each end of each tank.



Note: Although the closure of tanks in place may be allowed under certain circumstances in accordance with s. ILHR 10.732, a closure assessment is more difficult. The closure in place may also present problems if a remediation is necessary, in future property sales or in future construction.

- g. If the water table is found within the tank or piping excavation, soil samples should be collected at the side walls of the excavation at the locations described in IV(C)(1)(a-e) above.

Water which is removed from the excavation must be sampled and disposed of properly.

2. If no closure assessment is being completed because of obvious contamination, this fact must be noted on the tank inventory form (SBD-7437). Unless this is done, the owner may be identified as being in violation of the requirement to conduct an assessment at the time of tank closure.

If a closure assessment is not completed because of the identification of obvious contamination, all notifications and responsibilities, except for the submittal of the closure assessment, must be completed promptly.

D. Variances to sampling requirements:

If free product, soils with petroleum product odor or other conditions make it obvious that a site investigation and corrective action will be needed at a site, a closure assessment with soil sampling need not be completed. The contamination, however, must be immediately reported and a work plan for addressing the contamination developed and submitted to the DNR.

E. Field Instruments:

Field instruments including photoionization detectors, flame ionization detectors and portable gas chromatographs may be used for field screening of soil samples and to choose samples to be tested at a laboratory, thus potentially reducing the number of samples which must be laboratory analyzed. Field instruments must be used in accordance with DNR approved field instrument techniques (See Attachment 2).

If field instruments are used to screen soil samples, the "Field Procedures Plan" must describe all field screening procedures. Sample locations must be at least those specified in IV. C. When using field instruments, the following number of samples must still be sent to a laboratory:

| <u>Total Number Of<br/>Samples Field Tested</u> | <u>Minimum Number Of<br/>Samples To Laboratory</u> |
|---|--|
| 2-3   | 2 highest  |
| 4-7   | 3 highest  |
| 8 or more                                       | 5 highest  |

Even if no field samples show "detects," the minimum number of samples must still be sent to the laboratory for analysis.

V. Sample Collection Techniques

Soil samples must be collected using techniques for sample collection which are approved by the DNR. The most current versions of these methods are included as Attachment 3.

VI. Analytical Parameters and Methods

A. Parameters:

All soil samples sent to a laboratory must be analyzed for the parameters specified in Attachment 6. The results must be reported in parts per million on a dry weight basis.

B. Methods:

Soil analysis must be conducted by a laboratory certified under ch. NR 149, Wisconsin Administrative Code, for purgeable organics. All analytical methods must be approved by the DNR.

VII. Documentation Requirements for USTs

Closure assessments must be properly documented to show that the requirements of the state code and federal rules are met or exceeded. The following are minimum documentation requirements:

A. Site Background Information:

A narrative describing the following site background information must be included:

1. Site owner and UST system owner/operator;
2. Environmental consultant;
3. Excavation contractor;
4. Description of past and present property use;
5. Number of tanks on site currently and any previously removed;
6. Results of previous geotechnical investigations;

7. Information on system leaks or repairs; and
8. Site address and township range description to the quarter/quarter section.
9. Third party present at closure and closure assessment (if any).

B. Site Location Map:

A map describing the location of the site relative to nearby towns, streets or major highways. Blow-ups of USGS topographic maps, highway maps, or plat maps with the site location clearly marked are acceptable as a site location map.

C. Site Layout/Plot Plan:

The site layout/plot plan must be to scale and provide the locations of tanks, piping, dispensers, utilities, buildings, numbered field and laboratory sampling points and other relevant data clearly marked. Standard scale shall be 1" = 10'.

D. Tabulated Field and Laboratory Data:

All field screening data and laboratory results shall be presented in tabular form and correspond to the numbering on the "site layout." The field data submitted must also include the depths at which samples were taken and all of the information required in Attachment 2.

Copies of the laboratory analysis reports and chain of custody forms must also be submitted.

E. Narrative/Observations:

A narrative must be provided noting any presence of free product, soil staining, odors, soil types, depth of excavation, tank and piping conditions, possible leak locations, presence of free standing water in the excavation and other relevant observations.

F. Procedures:

Procedures for the following activities shall be reported:

1. Soil sampling techniques including sample collection and preservation methods, and sampling tool cleaning methods.
2. Field instrument methods including headspace techniques.

G. Photographs:

Photographs if submitted must be either color photocopies, originals, or reprints of originals. Black and white photocopies of photographs are not acceptable for documenting site conditions.

H. Documentation of Tank, Waste Product, and Sludge Disposal:

The closure assessment report must document the reuse, recycling or disposal of the tank and piping and the transportation, storage and disposal of any residues removed from the tank and piping including product, water and sludge accumulations. Minimum documentation shall include:

1. Tank cleaning methods.
  2. Names and addresses of firms or individuals removing or cleaning tanks and final destination of tank and waste products removed.
  3. Types and quantities of materials collected during cleaning.
  4. Methods and firms used to store, transport and dispose of tank waste residues.
  5. Waste characterization data.
  6. Copies of hazardous waste manifest and EPA generator i.d. numbers.
  7. Disposal or treatment of contaminated soil and backfill.
- I. Copies of Tank Inventory forms (SBD-7437) for all tanks being closed.
- J. Other:

Other information requested by DNR or DILHR.

VIII. Release Reporting

If a release is detected during the tank closure, change-in-service or the laboratory analysis of soil samples, the owner/operator must immediately report the release. The local DNR District Office should be contacted first. If the District Office can not be reached, the Division of Emergency Government Hot Line should be called at (608) 266-3232.

The necessary actions after reporting will vary depending on several factors including the degree of contamination, the depth to groundwater, and the nature of surrounding land use.

IX. Reporting of Tank Closures

The closure of an UST site must be reported to the Safety and Buildings Division through the use of a "Tank Inventory Form" (SBD-7437). This form is to be completed and submitted to the address shown on the form, by the owner/operator immediately after closure. The submitted form will be used to update the Division's UST inventory.

Copies of the full closure assessment report must be submitted to both DILHR and DNR. A copy of the "Tank Inventory Form" that reported the tank closure must be submitted with the site assessment. DILHR's copy must be sent to:

Bureau of Petroleum Inspection and Fire Protection  
P.O. Box 7969  
Madison, WI 53707

DNR's copy, if contamination was previously reported, is to be sent to the local District Office. If a determination of contamination has not been made, the report is to be sent to the:

Bureau of Solid and Hazardous Waste Management  
Environmental Response and Repair Section  
P.O. Box 7921  
Madison, WI 53707

The DNR will review the closure assessments on a site-by-site basis. Based upon the soil sampling results and site characteristics, the DNR will determine if further investigation or corrective action is needed. The DNR will request additional information if the minimum documentation requirements identified in this guideline are not met.

#### NOTICE

Section 144.76 (2)(a), Wis. Stats., requires any person who possesses or controls a hazardous substance or who causes the discharge of a hazardous substance to immediately notify the Wisconsin Department of Natural Resources (WDNR) of the discharge.

Petroleum products and their constituents are hazardous substances. WDNR must be immediately notified of all releases of petroleum products including leaking underground storage tanks, leaking piping and distribution systems and overfills.

Failure to notify WDNR of a discharge may have serious consequences including forfeitures of not less than \$10 or more than \$5000 for each violation (each day of continued violation is a separate offense) and ineligibility for reimbursement under the Petroleum Remedial Action Fund (PECFA, s. 101.143, Wis. Stats.).

ATTACHMENT 1  
CLOSURE OF UNDERGROUND STORAGE TANKS

I. You must notify your local fire department 15 days prior to closing a tank(s):

II. Tank closures must follow the requirements of either A or B below:

NOTE

Although the closure of tanks in place is allowed under certain circumstances in accordance with s. ILHR 10.732, a closure assessment is more difficult. The closure in place may also present problems if a remediation is necessary, in future property sales or in future construction.

A. Closure by removal and scrapping

1. Obtain a qualified company with certified employees to close the tank system.
2. Remove all flammable or combustible liquids, including any tank wastes or sludge, from the tank and all connecting lines. Piping is to be drained back to the tank and any product collected. Piping that is left in place shall be capped or plugged.
3. Render the tank vapor free by filling with an inert gas such as Nitrogen or Carbon dioxide, to prevent potential ignition. An educator type air mover or diffuser blower may also be used.
4. Clean the tank and properly store, transport and dispose of the waste (which may be hazardous).
5. Secure written documentation of the destination of the hazardous waste and a receipt for the scrapped tank.
6. Leakage which is detected by visual observation, smell, field instruments or laboratory analysis shall be reported to the DNR District Office or by calling the Division of Emergency Government Hotline Number: (608) 261-1212.
7. Tanks that are transported to a remote area for disposal shall have openings capped or plugged (provide 1/8" vent hole) while in transit.
8. Conduct a Closure Assessment if required by Federal EPA Rules or State Code.
9. File a Tank Inventory Form (SBD 7437) documenting the closure of each tank. Mail the forms to

Safety & Buildings Division  
P.O. Box 7969  
Madison, WI 53707

**B. Closure in place by filling with an inert material.**

1. Obtain a qualified company with certified employees to close the tank system.
2. Remove all flammable or combustible liquids, including any tank wastes or sludge, from the tank and all connecting lines. Piping is to be drained back to the tank and any product collected.
3. Render the tank vapor free by filling with an inert gas such as Nitrogen or Carbon dioxide, to prevent potential ignition. An educator type air mover or diffused blower may also be used.
4. Excavate to the top of the tank.
5. Remove drop tube, fill pipe, gauge pipe, and other fixtures. Vent line is to remain in place until tank is purged.
6. Clean the tank and properly store, transport and dispose of the waste (which may be hazardous).
7. Secure written documentation of the destination of the waste.
8. Leakage which is detected by visual observation, smell, field instruments or laboratory analysis must be reported to the DNR District Office or by calling the Division of Emergency Government Hotline Number: (608) 266-3232.
9. All piping left in place shall be capped or plugged.
10. Fill the tank completely with an inert solid material (sand, cyclone boiler slag or pea gravel is recommended). A tank can be opened up or filled through existing tank openings. It is important to fill the tank completely.
11. Remove the vent pipe and cap, plug or seal all tank openings.

ATTACHMENT 2  
CLOSURE OF UNDERGROUND STORAGE TANKS

Field instruments including photoionization detectors, flame ionization detectors and gas chromatographs may be used to field screen soil and groundwater samples using headspace techniques outlined in this attachment. Other types of field instruments may not be used to screen soil samples in the field without prior approval of the Department of Natural Resources.

Note: The term "headspace sample" is used herein to refer to samples collected for headspace analysis. Samples collected for laboratory analysis must be collected in glass or inert synthetic containers obtained from or approved by the certified laboratory which will analyze the samples.

A. General Requirements

1. A field instrument shall only be used by operators thoroughly familiar with the operation of the instrument. Operators shall, through training or education, be familiar with each of the following aspects of instrument use:
  - a. Principles of instrument operation;
  - b. Interferences;
  - c. Instrument sensitivity and linear range for petroleum constituents;
  - d. Calibration procedures;
  - e. General maintenance including filter cleaning;
  - f. Flame lighting techniques (for FIDs);
  - g. Battery maintenance.
2. The calibration of field instruments shall be checked at least once per operating day using methods approved by the manufacturer. FIDs shall be checked using methane or other appropriate commercial gases. PIDs shall be checked using an appropriate field standard such as benzene or isobutylene.
3. All samples shall be analyzed in a manner consistent with written procedures which substantially conform to this guidance.
4. If a headspace sample is found through headspace analysis to be contaminated and laboratory analysis is needed to confirm the analysis, the sample sent to the laboratory shall be a split sample from the same sampling point where the headspace sample was collected. Split samples shall be collected and immediately preserved at the same time the headspace sample is collected. Headspace samples shall not be submitted to environmental laboratories for analysis.



5. PIDs must have a lamp energy of 10.6 electrovolts or greater.

B. Headspace Sample Containers and Analytical Preparation

1. All headspace sample containers (with the exception of new polyethylene bags) must be thoroughly cleaned using water/detergent solutions, methanol, or other appropriate solvents. Following washing, sample containers shall undergo multiple rinses using distilled water.
2. Headspace sample containers shall be constructed of glass or inert synthetics. Bottles and caps may be reused if tested in advance for VOC carryover. New one-quart plastic bags may also be used. (See Part E below.)
3. Headspace samples shall be collected in accordance with Soil Sampling Requirements. (See Attachment 3 of Closure Assessment Procedures for Underground Storage Tanks.)
4. Headspace sample containers are to be filled 1/2 to 3/4 full. All headspace sample containers used at an UST site shall be the same size and shall be filled to the same volume. A headspace fill-line shall be marked on all containers.
5. Polyethylene bags which are used as headspace sample containers must be resealable freezer bags. A consistent sample/headspace ratio must be maintained. This can be achieved through the use of three-way valves (Imperial Eastman, Inc., No. 108-HD or equivalent) attached to the bags and sealed with Buna-N gaskets and lamp nuts. (See Figure below.) Once sealed, all bags shall be inflated to the same volume using a bicycle pump. Valves and connective tubing must be purged to prevent carryover from previous samples or replaced.

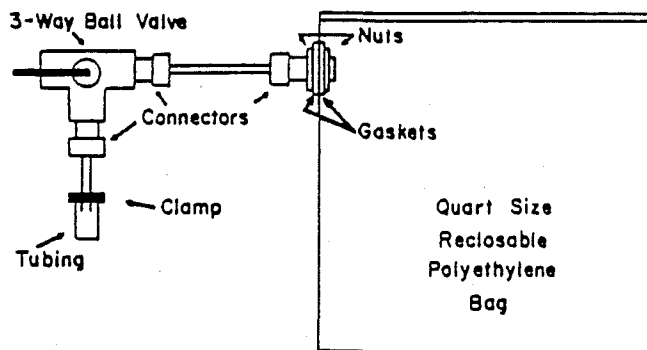

Figure source: Robbins, Gary A., R D. Bristol and V.D. Roe. 1989. A Field Screening Method for Gasoline Contamination Using a Polyethylene Bag Sampling System. Ground Water Monitoring Review, v. 9 no. 4, pp.87 - 97.

6. Headspace sample containers shall be closed or covered immediately. Sample containers shall be covered with heavy gauge aluminum foil or a tight fitting cap or collar equipped with a tight fitting capped septum. Tight fitting caps or collars may be used only if the field instrument is capable of drawing a sample under tension for a long enough period to take a stable reading.

C. Headspace Sample Analysis

1. Once collected and sealed, headspace samples shall be agitated for at least 30 seconds to break soil clods and release vapors. Headspace samples in containers sealed with aluminum foil shall first be capped to allow agitation without damage to the foil seal. Seals shall be left in place during warming and shall not be pierced until the headspace is analyzed.
2. Headspace samples must be allowed to equilibrate prior to analysis. Minimum equilibration time shall conform to the specifications in the Table below.

Minimum Sample Headspace Equilibration Time

| <u>Ambient Outside Air Temperature<br/>at Time of Sample Collection</u> | <u>Minimum Amount of Time Sample Must<br/>Equilibrate at 70°F or Greater<br/>Temperature*</u> |
|---|---|
| 40°F  | 40 min.   |
| 41 - 55°F   | 20 min.   |
| 56 - 69°F   | 10 min.   |
| 70°F  | 5 min.  |

\* Headspace samples shall be warmed out of direct sunlight by bringing them into a heated environment. At temperatures less than 55°F, headspace sample equilibration time can be reduced to 10 minutes through the use of a 70°F water bath.

3. Following equilibration, the sample headspace shall be analyzed promptly. The highest instrument reading shall be recorded. Time averaged readings may also be recorded but they are not a substitute for the highest instrument reading. Meter "quenching" shall be recorded if experienced. Care shall be taken to insert the instrument tip through a single small hole in the foil seal (if used) and to measure headspace at one-half the distance between the foil seal and the sample surface.

Note: The Department of Natural Resources interprets FID responses to be petroleum related unless there is independent confirmation that the gas is not petroleum derived.

D. Documentation

If field instruments are used in conjunction with an UST closure assessment, the following minimum documentation standards must be adhered to:

1. Record all relevant ambient conditions. At a minimum, record:
  - a. Ambient outside temperature,
  - b. Temperature where samples are held during equilibration, and
  - c. Weather conditions (e.g., light rain, windy).
2. Record all relevant instrument conditions including:
  - a. Instrument make and model,
  - b. Date of last factory calibration,
  - c. Field calibration gas used and concentration,
  - d. Date and time of last field calibration,
  - e. Lamp energy in electrovolts (for PIDs)
  - f. Instrument gain setting,
  - g. Erratic instrument readings, and
  - h. Cleaning or repairs performed in the field.
3. Record all field results including:
  - a. Headspace results as "instrument units as (calibration gas)." Example: 151 instrument units as benzene. DO NOT RECORD RESULTS AS CONCENTRATIONS UNLESS INSTRUMENT READINGS HAVE BEEN CALIBRATED AGAINST PREPARED SOIL/PETROLEUM PRODUCT CALIBRATION CURVES.
  - b. Relative sample moisture content. Example: Saturated, wet, moist, damp, dry.
  - c. Record any noticeable petroleum product odor for any sample.
  - d. Record instrument "quenching" caused by highly contaminated soils.

ATTACHMENT 3  
SOIL SAMPLING REQUIREMENTS

Soil samples collected to comply with Closure Assessment requirements shall comply with the following requirements.

A. General Requirements

1. Soil samples must be collected in a manner which causes the least disturbance to the sample.
2. Composite samples are not to be collected for purposes of complying with the closure assessment requirements.
3. All soil samples shall be properly labeled with the sample number and collection date.

B. Soil Sampling Methods

1. If the UST system is closed by removal of the tank system from the ground, the following sample collection method must be used:
  - a. If the excavation, pipe trench or other sampling location can be entered in accordance with applicable OSHA regulations, samples may be collected using a hand auger or trowel.
  - b. If the excavation, pipe trench or other sampling location cannot be entered safely for sampling, a sample must be collected from the excavation using a hand auger extension or from the backhoe bucket.
2. If the UST system is closed in place, soil samples shall be collected through one of the following techniques:
  - a. If the tank is entered for cleaning and samples are collected through holes cut in the tank, they shall be collected using a hand-held soil auger or trowel.
  - b. If the samples are to be collected by drilling, then split spoon (barrel, tube) samplers or thin-walled (Shelby) samplers must be used when conditions permit. Grab samples from drill cuttings cannot be used unless undisturbed samples are impossible to collect.
3. Whenever hand-held tools are used to collect samples, the first 3 to 4 inches of soil must be scraped away immediately before sampling so that the sample is collected from a previously unexposed soil area.

4. All soil sampling tools must be thoroughly cleaned between all sampling points using water/detergent solutions, methanol, or other appropriate solvents.

C. Sample Containers for Laboratory Analysis

1. Samples shall be collected in glass or inert synthetic containers obtained from or approved by the certified laboratory which will analyze the samples. Polyethylene bags are not to be used for laboratory samples.
2. All sample containers shall have Teflon® or equivalent lined caps.
3. Sample containers shall be filled to the top such that no headspace remains.
4. The use of "wide mouth" vials is highly recommended.

D. Sample Handling

1. Seal and label samples prior to collection or immediately following collection.
2. Chill samples immediately using adequate quantities of ice, "blue ice," or equivalent. Note: Closure assessment documentation requires analytical laboratories to report sample temperatures. Improper storage resulting in sample warming could result in rejection of report results.
3. Follow chain of custody procedures.
4. Ship samples to analytical laboratory as soon as possible. Do not allow samples to be held so long that the maximum holding time is violated.
5. Unless otherwise specified, the maximum holding time for soil samples collected for TPH analysis is 14 days.

NOTE: HEADSPACE ANALYSIS USING FIELD INSTRUMENTS SHOULD NOT BE PERFORMED ON SAMPLES COLLECTED FOR LAB ANALYSIS. DUPLICATE SAMPLES SHOULD BE COLLECTED FOR HEADSPACE AND ANALYSIS.

ATTACHMENT 4  
WISCONSIN DEPARTMENT OF NATURAL RESOURCES  
PETROLEUM TANK AND SLUDGE MANAGEMENT FACTSHEET

Many owners of underground storage tanks (USTs) are in the process of removing or upgrading their tanks to come into compliance with new Environmental Protection Agency (EPA) regulations. Tank owners are responsible for properly managing any waste and product that remains in tanks which are being upgraded or removed.

The Department of Industry, Labor and Human Relations (DILHR) regulates petroleum products. See "Management of Petroleum Products at Tank Closure" for product handling guidance. DILHR considers tank contents less than 2 inches above the water line or the tank bottom to be wastes. These wastes are regulated by the Department of Natural Resources (WDNR) as either sludge or wastewater.

Tank sludge is a solid waste regulated under ch. 144, Wis. Stats. Depending on the products stored in tanks, it may also be hazardous waste. The state has the authority to impose civil or criminal penalties against tank owners, tank excavators, tank transporters, and tank salvagers who improperly dispose of tank sludge. The tank owner is responsible for classifying tank waste and making sure it is properly handled and disposed of in compliance with the regulations. Wastewater is regulated by WDNR chs. 144 and 147, Wis. Stats.

An owner or operator who permits improper disposal may become ineligible for reimbursement under the state's Petroleum Storage Remedial Action Fund (PECFA).

#### WASTEWATER HANDLING

Wastewater may be generated from either removal of tank condensate or from tank washing. It must be disposed of legally. Some tank excavation services include wastewater disposal. In sewered areas, you may contact the municipal wastewater treatment plant for disposal approval. In unsewered areas, you may contact a licensed septic disposal service to transport wastewater to a wastewater treatment plant. Septic haulers may not transport flammable liquids. Identify an acceptable method to dispose of wastewater prior to excavating tanks.

## SLUDGE HANDLING

Tank sludge is solid waste. Tank owners are responsible for determining if it is also hazardous waste, and, if so, characterizing and managing it in accordance with all state and federal regulations. This is a technical procedure which should be handled by an experienced hazardous waste contractor. If there is a possibility that at any time the tank contents were not clean fuels, additional analysis is required to identify residual wastes (PCBs, solvents, etc.). Complete analysis must be performed for waste oil tank sludges.

Tank sludge which has been classified as nonhazardous may be:

- a. Removed by a waste oil service for recycling.
- b. Disposed of in a licensed sanitary landfill with a clay liner if the sludge does not contain free liquids as determined by the paint filter test (EPA SW-846 methods, update II). Free liquids may be absorbed by adding clean absorbent materials such as sawdust or vermiculite.

Tank sludge which has been classified as hazardous must be:

- a. Transported to a licensed treatment, storage or disposal facility by a licensed hazardous waste transportation service.
- b. Manifested for transportation using a U.S. Environmental Protection Agency (EPA) identification (ID) number.

ID numbers can be obtained by completing an EPA notification form (8700-12, rev. 10-88). This form can be obtained from WDNR and must be submitted to:

US EPA Region V  
Attn: EPA ID Number  
P.O. Box A-3587  
Chicago, Illinois 60690

The EPA ID number should be requested six weeks prior to tank excavation. ID numbers can not be obtained from WDNR.

Sludge may be held on site while laboratory analysis is being completed or it may be transported immediately by a licensed transporter. (Liquid tank sludge may be manifested as ignitable waste.) Some tank excavation companies offer sludge analysis and disposal services.

Sludge which is being held on site should be handled as follows:

- a. Consult the laboratory prior to sampling to determine proper sampling procedures and sample containers.

- b. Carefully transfer the sludge from the tank to a metal drum. Seal the drum, affix the date and label it "Petroleum Tank Sludge."
- c. To avoid contaminating nonhazardous sludge with hazardous sludge from other tanks, do not mix sludges from different tanks. Each sample jar and each sludge drum must be identified by matching numbers or descriptions.
- d. Handle sludge with care! Anyone transferring sludge must have proper training and wear protective clothing and gloves.
- e. Avoid spills! Spilling sludge may contaminate an otherwise clean tank excavation site. You must immediately report any spill to WDNR and clean up the spill.
- f. Maintain the drums containing sludge in good condition and in a secure location while waiting for laboratory results. Report the location of sludge drums in the tank closure assessment report which you provide to DILHR and WDNR.



## TANK HANDLING

1. Clean tanks on site. It is illegal to transport tanks containing residues of hazardous waste without a variance or emergency waiver from WDNR District hazardous waste staff. Uncleaned tanks present an explosive risk to the public. Interstate carriers must obtain United States Department of Transportation approval to carry uncleaned tanks which have held hazardous materials.
2. Before removing sludge, cleaning tanks, and transporting tanks, fill the tanks with inert gases or properly vent them as per DILHR requirements to remove explosive vapors. Occupational Health and Safety Administration (OSHA) confined space entry regulations apply.
3. Properly cleaned tanks may be recycled for scrap metal. WDNR does not regulate scrap metal recycling.

### ADDITIONAL INFORMATION AVAILABLE

Tank Excavation Services: Bureau of Petroleum Inspection & Fire Protection  
Department of Industry, Labor and Human Relations  
201 East Washington Avenue  
Madison, Wisconsin 53702

Hazardous Waste Management Services:  
Bureau of Solid & Hazardous Waste Management  
Department of Natural Resources  
P.O. Box 7921  
Madison, Wisconsin 53707

Certified Laboratories: Office of Technical Services  
Department of Natural Resources  
P.O. Box 7921  
Madison, Wisconsin 53707

### Additional FACTSHEETS Available from WDNR:

"What is Hazardous Waste?"  
"EPA Identification Number"  
"Notification of Hazardous Waste Activity"

WDNR factsheets and forms to obtain EPA identification numbers can also be obtained from WDNR District Offices. A map of District Offices is attached.

This factsheet is a summary of regulations. It may not be used as a substitute for the statutes and codes administered by the Departments of Natural Resources; Industry, Labor and Human Relations; Transportation; or the federal government. Consult the regulations and statutes for specific information. Remember, a tank owner, tank excavator, tank transporter and tank salvager may all be liable for improper sludge transportation and disposal.

ATTACHMENT 5  
MANAGEMENT OF PETROLEUM PRODUCTS AT TIME OF TANK CLOSURE

The closure of a petroleum product storage tank system will result in the necessity to manage the petroleum product remaining in the tank at closure. Petroleum product in this instance means products regulated by DILHR under ILHR 48, the Petroleum Products Administrative Code.

Petroleum products which meet the standards of ILHR 48 or will be blended to meet the standards fall within the jurisdiction of the Petroleum Inspection Program. Wastewater, product water interfaces, petroleum directly above the product water interface and sludges fall within the scope of the Wisconsin Department of Natural Resources. The DNR factsheet titled "Petroleum Tank and Sludge Management Factsheet" which is Attachment 4 should be referred to for guidance on waste management.

The following requirements have been established by the Petroleum Inspection Program for the handling and use of petroleum products generated at tank system closures. The requirements which have been established reflect the Department's authority under Chapter 168 of the statutes and ILHR 48, Wisconsin Administrative Code.

1. To the extent practical, given the timing of the tank closure, as much product as possible should be used prior to tank closure.
2. Product for use or transfer to other facilities may be pumped off to a maximum depth of 2 inches above the water level in the tank or 2 inches above the tank bottom, whichever is higher.
3. Below the 2-inch level, all liquids and solids are considered a waste and are regulated by the Department of Natural Resources.
4. The removal and transfer of any product destined for use or return to a terminal or refinery must be by a tank vehicle which complies with the "Standards for Tank Vehicles for Flammable and Combustible Liquids."
5. Product which is removed from the tank above the 2-inch level may be:
  - a. Returned to a terminal slop tank, if a terminal will accept it.
  - b. Returned to a refiner if the company will accept it.
6. If the desire is to use the product taken from the tank system, it may be accomplished in the following ways:
  - a. Gasoline may be transferred to another facility for storage and use. Storage must meet the standards established in the Flammable and Combustible Liquids Code and the EPA rules.

- b. Terminals or refineries may purchase gasolines and blend them with new gasoline at their facility. The gasoline purchased must be treated as "interface" and the blend rate must not exceed 1/2 of 1 percent.
  - c. Oils removed during tank closure must be downgraded to #2 fuel oil. Products classified as kerosene, #1 diesel, #2 diesel, #1 fuel oil or #2 fuel oil may be blended with new #2 fuel oil (at up to a 50 percent rate) and used or sold for heating purposes.
  - d. Products heavier than #2 fuel oil may be blended with an equal or heavier stock (at up to a 50 percent rate) and sold for or used for heating purposes.
  - e. Oils may also be sold without blending for nonsensitive burner and heating use if the purchasers have established themselves as a qualified buyer/user with the District Petroleum Inspection Office.
7. When product quantities of 500 gallons or more are involved, the DILHR District Petroleum Inspection Office must be contacted. Based upon the contact, the Petroleum Inspection staff will determine the disposition of the product. The staff may:
- a. Sample and test the product to determine compliance with ILHR 48, Wisconsin Administrative Code, and then provide directions for disposition.
  - b. Allow transfer of the product to another station or facility for use or sale.
  - c. Classify the product as falling outside the scope of ILHR 48, Wisconsin Administrative Code. (If the material tested falls outside the scope of the Administrative Code, the product may be determined to be a waste and within the jurisdiction of the Department of Natural Resources.)

ATTACHMENT 6  
CLOSURE ASSESSMENT ANALYTICAL REQUIREMENTS

All samples collected for purposes of complying with Section IV of "Closure Assessments for Underground Storage Tanks" must be analyzed for total petroleum hydrocarbons using procedures specified in the "California Leaking Underground Fuel Tank Manual." In addition to sample results, the documentation must include the following items:

1. Sample condition upon receipt by the environmental laboratory including sample temperature;
2. Date of analysis;
3. Description of the laboratory's sample storage technique including methods used to keep samples cold;
4. Analytical method detection limits;
5. Sample results reported in ppm on a dry/weight basis for the petroleum product used as a quantitation standard. For example: "TPH as Gasoline" or "TPH as Number 2 Fuel Oil";
6. For "unknown" petroleum products or samples whose chromatographs don't match the petroleum product stored in the tank, explain the decision criteria used to determine the appropriate standard.

Note: The Department of Natural Resources is currently reviewing the analytical requirements for soil and groundwater sample analysis in the LUST program. The review is expected to result in a revised analytical method for total petroleum hydrocarbons and revisions of the parameters and methods used during investigations of confirmed petroleum releases. When completed, the analytical requirements will be distributed to consultants and analytical laboratories.

SECTION 2. Ch. Ind 8 is repealed.

SECTION 3. Ind 69.10 (1) is repealed and recreated to read:

Ind 69.10 (1) Fees for the examination of plans and site inspections for tanks used for the storage of flammable and combustible liquids, liquefied petroleum gas, liquefied natural gas and compressed natural gas shall be determined in accordance with Table 69.10.

SECTION 4. Ind 69.10 (1) Table 69.10 is repealed and recreated to read:

Table 69.10

| Type of Registration, Renewal, Examination or Inspection   | Fee  |
|--|--|
| <b>FLAMMABLE LIQUID TANK SYSTEMS OR COMBUSTIBLE LIQUID TANK SYSTEMS OR COMPONENTS OF TANK SYSTEMS</b>  |  |
| Plan Examination   |  |
| All Tanks Under 5000 Gallon Capacity . . . .   | (No state plan examination fee required; local authorized agent will charge a fee which must be at least equal to the state fee minus the groundwater surcharge. |
| All Tank Systems within Scope of Subch. VI of ch. ILHR 10 and Aboveground Tank Systems within the Scope of Subch. VI and Having a 5000 Gallon Capacity or Larger |  |
| Plans With 10 or Fewer Tank Systems . . . .<br>or Components of Tank Systems   | \$35.00 for the first tank system or component of a tank system plus \$10.00 for each additional tank system or component of a tank system.                      |
| Plans With 11 or More Tank Systems . . . .<br>or Components of Tanks Systems   | \$150.00   |
| Site Inspection Fees   |  |
| Installations With Only One Tank System . . . .<br>or Component of a Tank System   | .\$100.00  |
| Installations With Two or More Tank Systems . . . .<br>or Components of Tank Systems   | .\$ 50.00 for each tank or component of a tank system up to \$1700.00.   |
| Miscellaneous Plan Review and Inspection   |  |
| Addition of Spill or Overfill Protection Only . . .  | .\$22.00   |
| Addition of Leak Detection . . . . .   | .\$22.00   |
| Addition of Corrosion Protection . . . . .   | .\$22.00   |
| Lining . . . . .   | .\$22.00   |
| Conversion of Full-Service Stations to Self-Service or Conversion to Key-Card-Code . . .   | .\$35.00   |
| Site Inspection for Plan Reviews in This Section   | .\$43.00   |
| <b>LIQUEFIED PETROLEUM GAS, NATURAL GAS OR COMPRESSED NATURAL GAS</b>  |  |
| 125 to 1,999 gallon water capacity tank . . . .  | (No state examination or inspection fee required; local fire department shall be provided with a Compliance Certification Form at time of installation)          |
| 2000 Gallon Water Capacity and Above   |  |
| Plan Examination Fee . . . . .   | \$43.00 per tank   |
| Site Inspection Fee . . . . .  | \$43.00 per tank   |

PLAN REVISIONS

Plan Revision Examination Fee . . . . . \$22.00 per revised plan

SECTION 5. Ind 69.125 is created to read:

Ind 69.125 CERTIFICATION OF UST SYSTEM SPECIALTIES. All applicants for certification as a UST system installer, tightness tester, or remover, cleaner, reliner, inspector or site assessment provider shall submit, with the application form, fees as specified in this section.

(1) APPLICATION AND INITIAL CERTIFICATION. Persons applying for certification in one or more of the categories specified in sub. (2), shall submit a fee of \$100.00 for each 2 categories for which certification is requested.

(2) CATEGORIES OF CERTIFICATION. Persons may be certified in one or more of the following categories:

- (a) Installer.
- (b) Remover.
- (c) Tightness tester.
- (d) Cleaner.
- (e) Reliner.
- (f) Inspector.
- (g) Site assessment provider.

(3) EXAMINATION. Upon determination of eligibility for examination for certification, fees shall be submitted for examination and reexamination as follows:

- (a) Initial examination . . . . . \$10.00 per category
- (b) Examination retakes . . . . . \$10.00 per examination  
per category

(4) EXAMINATION AND TRAINING SEMINARS. Fees shall be assessed on an individual basis from education and training programs the department sponsors or participates in.

(5) RECERTIFICATION. The recertification fee for 2 categories of certification shall be \$100.00 per person.

\*\*\*\*\*

EFFECTIVE DATE

Pursuant to s. 227.026 (1) (intro.), Stats., these rules, shall take effect on the first day of the month following publication in the Wisconsin Administrative Register.

\*\*\*\*\*

**RECEIVED**

JAN 24 1991

Revisor of Statutes  
Bureau