

Chapter SPS 341 APPENDIX A

EXCERPTS FROM: ASME BOILER AND PRESSURE VESSEL CODE SECTION I - POWER BOILERS 2010 EDITION

INTRODUCTION

This Code covers rules for construction of power boilers¹, electric boilers², miniature boilers³, high-temperature water boilers⁴, heat recovery steam generators⁵, and certain fired pressure vessels⁶ to be used in stationary service and includes those power boilers used in locomotive, portable, and traction service. Reference to a paragraph includes all the subparagraphs and subdivisions under that paragraph.

¹ Power boiler - a boiler in which steam or other vapor is generated at a pressure of more than 15 psi (100 kPa) for use external to itself.

² Electric boiler - a power boiler or a high-temperature water boiler in which the source of heat is electricity.

³ Miniature boiler - a power boiler or a high-temperature water boiler in which the limits specified in PMB-2 are not exceeded.

⁴ High-temperature water boiler - a water boiler intended for operation at pressures in excess of 160 psi (1.1 MPa) and/or temperatures in excess of 250°F (120°C).

⁵ Heat recovery steam generator (HRSG) - a boiler that has as its principal source of thermal energy a hot gas stream having high-ramp rates and temperatures such as the exhaust of a gas turbine.

⁶ Fired pressure vessel - reheaters, isolable superheaters, and nonintegral separately fired superheaters.

The Code does not contain rules to cover all details of design and construction. Where complete details are not given, it is intended that the manufacturer, subject to the acceptance of the Authorized Inspector, shall provide details of design and construction which will be as safe as otherwise provided by the rules in the Code.

The scope of jurisdiction of Section I applies to the boiler proper and to the boiler external piping.

Superheaters, economizers, and other pressure parts connected directly to the boiler without intervening valves shall be considered as parts of the boiler proper, and their construction shall conform to Section I rules.

Boiler external piping shall be considered as that piping which begins where the boiler proper or isolable superheater, or isolable economizer terminates at:

- (a) the first circumferential joint for welding end connections; or
- (b) the face of the first flange in bolted flanged connections; or
- (c) the first threaded joint in that type of connection; and which extends up to and including the valve or valves required by this Code.

ASME Code Certification (including Data Forms and Code Symbol Stamping), and/or inspection by the Authorized Inspector, when required by this Code, is required for the boiler proper and the boiler external piping.

Construction rules for materials, design, fabrication, installation, and testing of the boiler external piping are contained in ASME B31.1, Power Piping. Piping beyond the valve or valves required by Section I is not within the scope of Section I, and it

is not the intent that the Code Symbol Stamp be applied to such piping or any other piping.

The material for forced-circulation boilers, boilers with no fixed steam and water line, and high-temperature water boilers shall conform to the requirements of the Code. All other requirements shall also be met except where they relate to special features of construction made necessary in boilers of these types, and to accessories that are manifestly not needed or used in connection with such boilers, such as water gages and water columns.

Reheaters receiving steam which has passed through part of a turbine or other prime mover and separately fired steam superheaters which are not integral with the boiler are considered fired pressure vessels and their construction shall comply with Code requirements for superheaters, including safety devices. Piping between the reheater connections and the turbine or other prime mover is not within the scope of the Code. Steam piping to the inlet connections and from the outlet connections of nonintegral separately fired superheaters is not within the scope of the Code.

A pressure vessel in which steam is generated by the application of heat resulting from the combustion of fuel (solid, liquid, or gaseous) shall be classed as a fired steam boiler.

Unfired pressure vessels in which steam is generated shall be classed as unfired steam boilers with the following exceptions:

- (a) vessels known as evaporators or heat exchangers
- (b) vessels in which steam is generated by the use of heat resulting from operation of a processing system containing a number of pressure vessels such as used in the manufacture of chemical and petroleum products

Unfired steam boilers shall be constructed under the provisions of Section I or Section VIII.

Expansion tanks connected to high-temperature water boilers without intervening valves shall be constructed to the requirements of Section I or Section VIII.

A pressure vessel in which an organic fluid is vaporized by the application of heat resulting from the combustion of fuel (solid, liquid, or gaseous) shall be constructed under the provisions of Section I. Vessels in which vapor is generated incidental to the operation of a processing system, containing a number of pressure vessels such as used in chemical and petroleum manufacture, are not covered by the rules of Section I.

PART PG GENERAL REQUIREMENTS FOR ALL METHODS OF CONSTRUCTION GENERAL

PG-1 SCOPE

The requirements of Part PG apply to power boilers and high pressure, high-temperature water boilers and to parts and appar-

tenances thereto and shall be used in conjunction with the specific requirements in the applicable Parts of this Section that pertain to the methods of construction used.

PG-2 SERVICE LIMITATIONS

PG-2.1 The rules of this Section are applicable to the following services:

- (a) boilers in which steam or other vapor is generated at a pressure of more than 15 psig (100kPa)
- (b) high-temperature water boilers intended for operation at pressures exceeding 160 psig (1.1 MPa) and/or temperatures exceeding 250°F (120°C)

PG-2.2 For services below those specified in PG-2.1 it is intended that rules of Section IV apply; however, boilers for such services may be constructed and stamped in accordance with this Section provided all applicable requirements are met.

PG-2.3 Coil-type hot water boilers where the water can flash into steam when released directly to the atmosphere through a manually operated nozzle may be exempted from the rules of this Section provided the following conditions are met:

- (a) There is no drum, header, or other steam space.
- (b) No steam is generated within the coil.
- (c) Tubing outside diameter does not exceed 1 in. (25 mm).
- (d) Pipe size does not exceed NPS ¾ (DN 20).
- (e) Nominal water capacity does not exceed 6 gal (23 L).
- (f) Water temperature does not exceed 350°F (175°C).
- (g) Adequate safety relief valves and controls are provided.

PG-3 REFERENCED STANDARDS

Specific editions of standards referenced in this Section are shown in A-360.

PG-4 UNITS

Either U.S. Customary units or SI units may be used for compliance with all requirements of this edition, but one system shall be used consistently throughout for all phases of construction.

Either the U.S. Customary units or SI units that are listed in Mandatory Appendix II are identified in the text, or are identified in the nomenclature for equations, shall be used consistently for all phases of construction (e.g., materials, design, fabrication, and reports). Since values in the two systems are not exact equivalents, each system shall be used independently of the other without mixing U.S. Customary units and SI units.

When SI units are selected, U.S. Customary values in referenced specifications that do not contain SI units shall be converted to SI values to at least three significant figures for use in calculations and other aspects of construction.

MATERIALS

PG-5 GENERAL

PG-5.1 Except as otherwise permitted in PG-8.2, PG-8.3, PG-10, and PG-11, material subject to stress due to pressure shall conform to one of the specifications given in Section II and shall be limited to those that are listed in the Tables of Section II, Part D. The manufacturer shall ensure that the correct material has been received and is properly identified before proceeding with construction (see A-302.4). Materials shall not be used at temperatures above those for which stress values are limited, for Section I construction, in the Tables of Section II, Part D. Specific additional requirements described in PG-5 through PG-13 shall be met as applicable.

PG-5.2 Material covered by specifications in Section II is

not restricted as to the method of production unless so stated in the specification, and as long as the product complies with the requirements of the specification.

PG-5.3 If, in the development of the art of boiler construction, it is desired to use materials other than those herein described, data should be submitted to the Boiler and Pressure Vessel Committee in accordance with the requirements of Appendix 5 of Section II, Part D. Material not completely identified with any approved Code specifications may be used in the construction of boilers under the conditions outlined in PG-10.

PG-5.4 Size Limits and Tolerances

PG-5.4.1 Materials outside the limits of size or thickness given in the title or scope clause of any specification in Section II may be used if the material is in compliance with the other requirements of the specification, and no similar limitation is given in the rules for construction.

PG-5.4.2 Pipe having a tolerance of $\pm 1\%$ on either the O.D. or the I.D. rather than the tolerance specified in the material specification, may be used, provided the material complies with all other requirements of the specifications. When used under external pressure, such pipe shall be limited to a maximum of 24 in. (600 mm) in diameter. The pipe shall include the designation 1% O.D. or 1% I.D., as appropriate, in any required documentation and marking of the material.

PG-5.5 The use of austenitic alloy steel is permitted for boiler pressure parts that are steam touched in normal operation. Except as specifically provided in PG-9.1.1, PG-12, and PEB-5.3, the use of such austenitic alloys for boiler pressure parts that are water wetted in normal service is prohibited.⁷

⁷ Austenitic alloys are susceptible to intergranular corrosion and stress corrosion cracking when used in boiler applications in water wetted service. Factors that affect the sensitivity to these metallurgical phenomena are applied or residual stress and water chemistry. Susceptibility to attack is usually enhanced by using the material in a stressed condition with a concentration of corrosive agents (e.g., chlorides, caustic, or reduced sulfur species). For successful operation in water environments, residual and applied stresses must be minimized and careful attention must be paid to continuous control of water chemistry.

PG-5.6 P-No. 15E, Group 1 Materials

PG-5.6.1 If during any phase of manufacturing or erection any portion of the component that does not contain a weld is heated to a temperature greater than 1,470°F (800°C), one of the following actions shall be performed:

(a) The component shall be re-austenitized and retempered in its entirety in accordance with the specification requirements.

(b) That portion of the component heated above 1,470°F (800°C), including the heat-affected zone created by the local heating, must be replaced or must be removed, re-austenitized, and retempered in accordance with the specification requirements and then replaced in the component.

(c) If the allowable stress values to be used are less than or equal to those provided in Table 1A of Section II, Part D for Grade 9 (e.g., SA-213 T9, SA-335 P9, or equivalent product specifications) at the design temperature, then the requirements stated above may be waived, provided that the portion of the component heated above 1,470°F (800°C) is retempered in accordance with the specification requirements. The use of this provision shall be noted on the Manufacturer's Data Report.

PG-5.6.2 If during any phase of manufacturing or erection of the component, any portion that does contain a weld is heated above 1,425°F (775°C), then the requirements of Notes (3) and

(4) of Table PW-39 for P-No. 15E, Group 1 Materials, shall apply for reheat treatment.

PG-6 PLATE

PG-6.1 Steel plates for any part of a boiler subject to pressure, whether or not exposed to the fire or products of combustion shall be of pressure vessel quality in accordance with one of the following specifications:

SA-202 Pressure Vessel Plates, Alloy Steel, Chromium-Manganese-Silicon

SA-204 Pressure Vessel Plates, Alloy Steel, Molybdenum

SA-240 (Type 405 only) Pressure Vessel Plates, Alloy Steel (Ferritic Stainless), Chromium

SA-285 Pressure Vessel Plates, Carbon Steel, Low-and Intermediate-Tensile Strength

SA-299 Pressure Vessel Plates, Carbon Steel, Manganese-Silicon

SA-302 Pressure Vessel Plates, Alloy Steel, Manganese-Molybdenum and Manganese-Molybdenum-Nickel

SA-387 Pressure Vessel Plates, Alloy Steel, Chromium-Molybdenum

SA-515 Pressure Vessel Plates, Carbon Steel, for Intermediate- and Higher-Temperature Service

SA-516 Pressure Vessel Plates, Carbon Steel, for Moderate- and Lower-Temperature Service

SA/AS 1548 Steel Plates for Pressure Equipment

SA/EN-10028-2 Flat Products Made of Steels for Pressure Purposes

SA/JIS G3118 Carbon Steel Plates for Pressure Vessels for Intermediate and Moderate Temperature Service

PG-55 SUPPORTS AND ATTACHMENT LUGS

PG-55.1 Lugs or hangers when used to support a boiler of any type shall be properly fitted to the surfaces to which they are attached.

PG-55.2 Lugs, hangers, or brackets may be attached by fusion welding provided the welding meets the requirements of Part PW, including stress relieving but omitting volumetric examination and provided they are attached by full penetration welds, combination groove and fillet welds, or by fillet welds along the entire periphery or contact edges. Some acceptable forms of welds for lugs, hangers, or brackets are shown in Fig. PW-16.2. The materials for lugs, hangers, or brackets are not limited to those listed in Tables 1A and 1B of Section II, Part D, but shall be of weldable quality. The allowable load on the fillet welds shall equal the product of the weld area based on minimum leg dimension, the allowable stress value in tension of the material being welded, and the factor 0.55. When using welded pipe, the stress values given in Table 1A of Section II, Part D, may be increased to that of the basic material by eliminating the stated weld efficiencies.

FIG. PG-58.3.1(a) CODE JURISDICTIONAL LIMITS FOR PIPING — DRUM-TYPE BOILERS

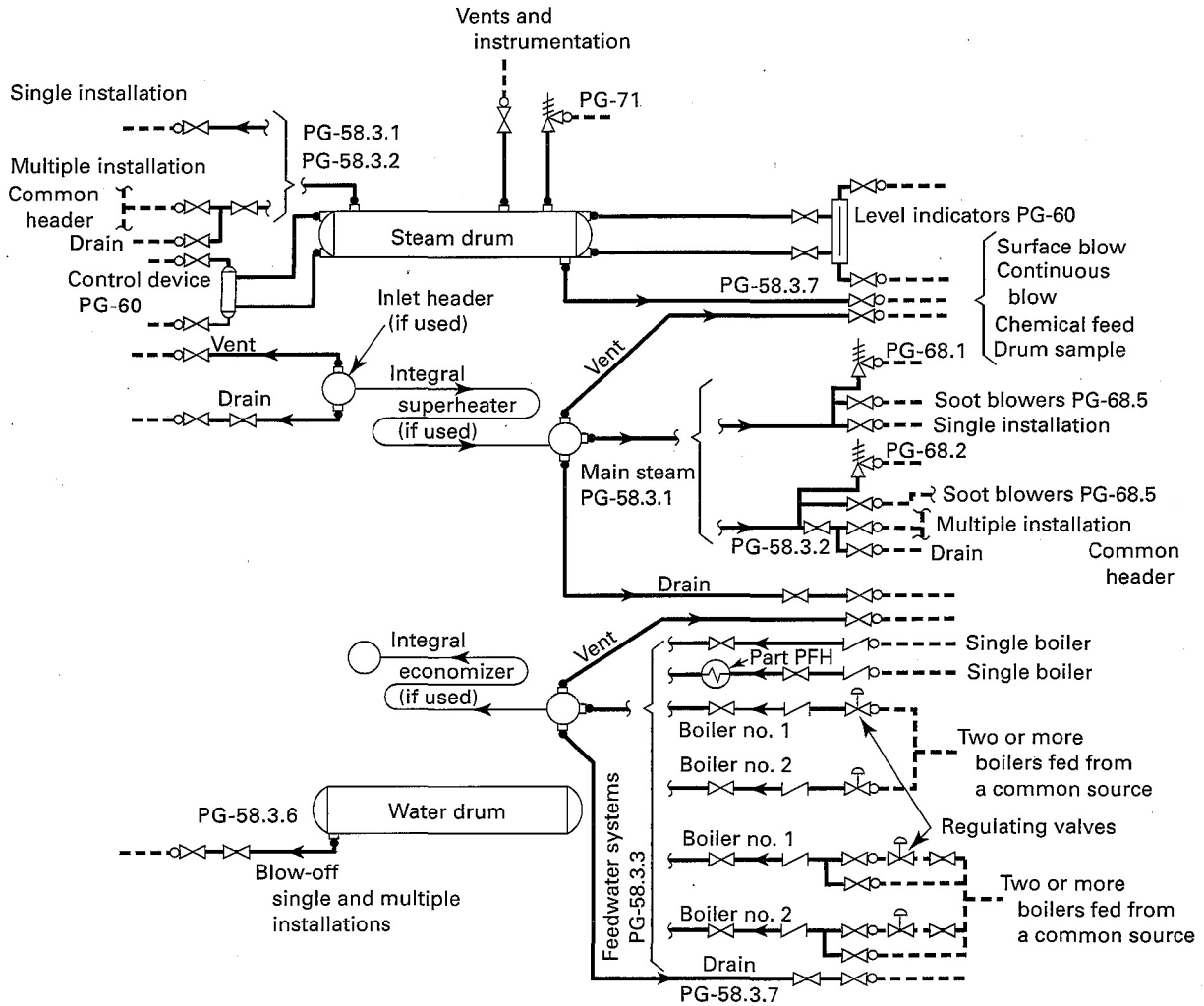

Administrative Jurisdiction & Technical Responsibility

- Boiler Proper — The ASME Boiler and Pressure Vessel Code (ASME BPVC) has total administrative jurisdiction and technical responsibility (refer to Section I Preamble)
- Boiler External Piping and Joint — The ASME BPVC has total administrative jurisdiction (mandatory certification by Code Symbol stamping, ASME Data Forms, and Authorized Inspection) of Boiler External Piping and Joint. The ASME Section Committee B31.1 has been assigned technical responsibility.
- Non-Boiler External Piping and Joint — Not Section I jurisdiction (see applicable ASME B31 Code).

FIG. PG-58.3.1(b) CODE JURISDICTIONAL LIMITS FOR PIPING — ISOLABLE ECONOMIZERS LOCATED IN FEEDWATER PIPING AND ISOLABLE SUPERHEATERS IN MAIN STEAM PIPING

(Boiler Pressure Relief Valves, Blowoff, and Miscellaneous Piping for Boiler Proper Not Shown for Clarity)

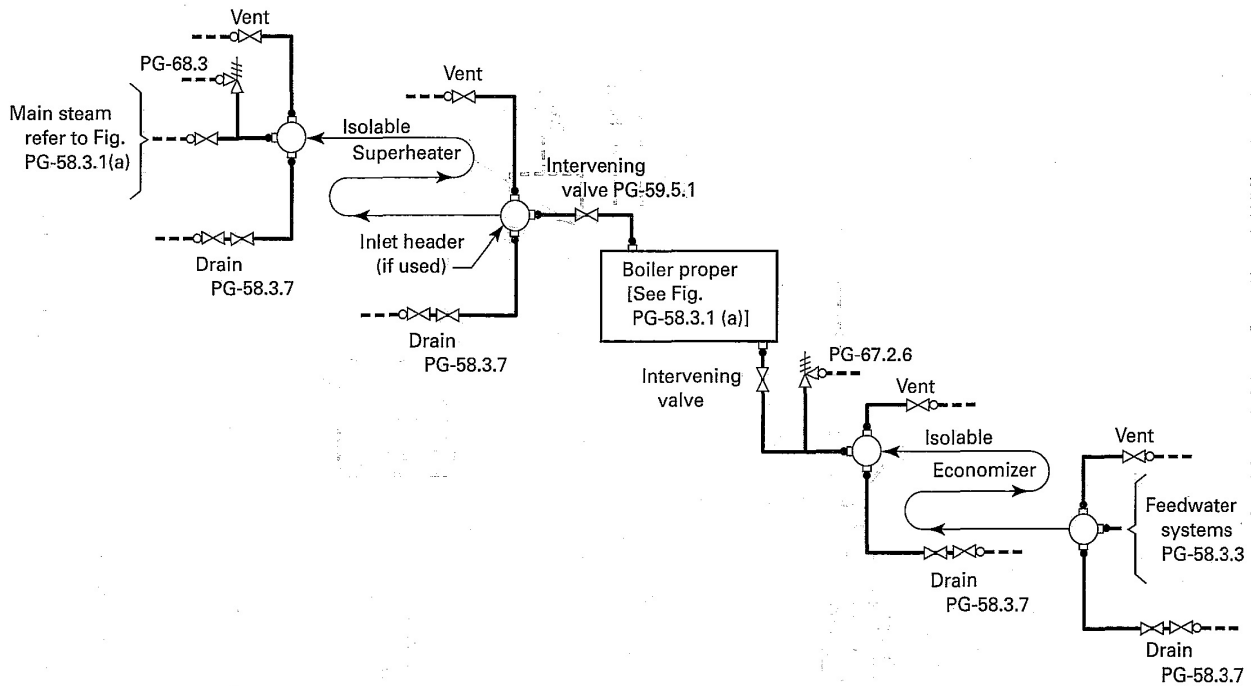

Administrative Jurisdiction & Technical Responsibility

- Boiler Proper — The ASME Boiler and Pressure Vessel Code (ASME BPVC) has total administrative jurisdiction and technical responsibility (refer to Section I Preamble)
- Boiler External Piping and Joint — The ASME BPVC has total administrative jurisdiction (mandatory certification by Code Symbol stamping, ASME Data Forms, and Authorized Inspection) of Boiler External Piping and Joint. The ASME Section Committee B31.1 has been assigned technical responsibility.
- Non-Boiler External Piping and Joint — Not Section I jurisdiction (see applicable ASME B31 Code).

FIG. PG-58.3.1(c) CODE JURISDICTIONAL LIMITS FOR PIPING — REHEATERS AND NONINTEGRAL SEPARATELY FIRED SUPERHEATERS

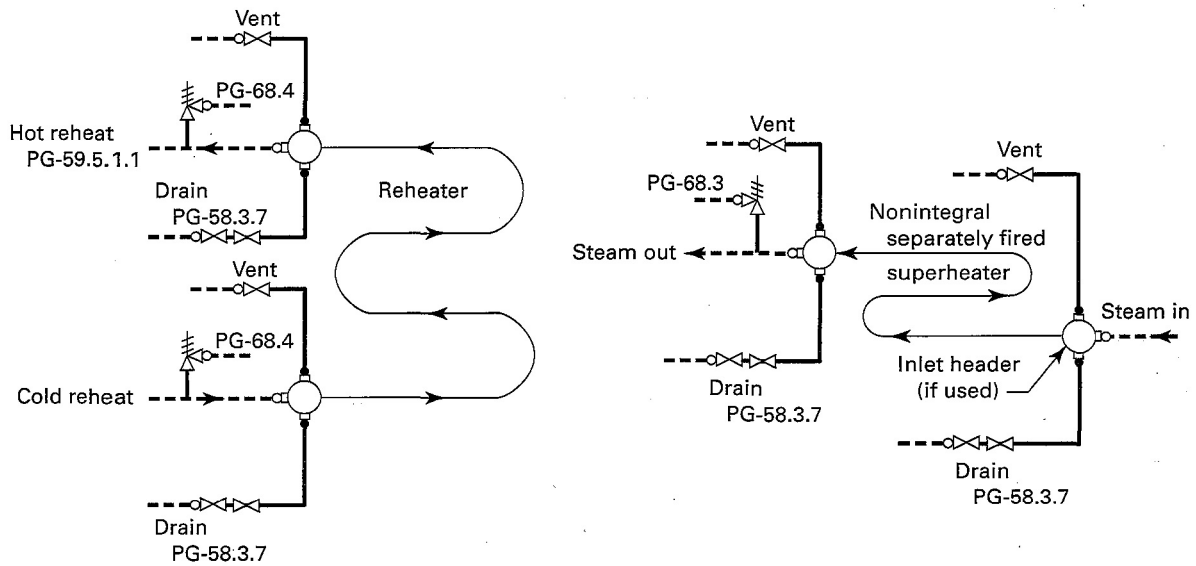

Administrative Jurisdiction & Technical Responsibility

- Boiler Proper — The ASME Boiler and Pressure Vessel Code (ASME BPVC) has total administrative jurisdiction and technical responsibility (refer to Section I Preamble)
- Boiler External Piping and Joint — The ASME BPVC has total administrative jurisdiction (mandatory certification by Code Symbol stamping, ASME Data Forms, and Authorized Inspection) of Boiler External Piping and Joint. The ASME Section Committee B31.1 has been assigned technical responsibility.
- Non-Boiler External Piping and Joint — Not Section I jurisdiction (see applicable ASME B31 Code).

FIG. PG-58.3.2 CODE JURISDICTIONAL LIMITS FOR PIPING — AN EXAMPLE OF FORCED-FLOW STEAM GENERATORS WITH NO FIXED STEAM OR WATERLINE

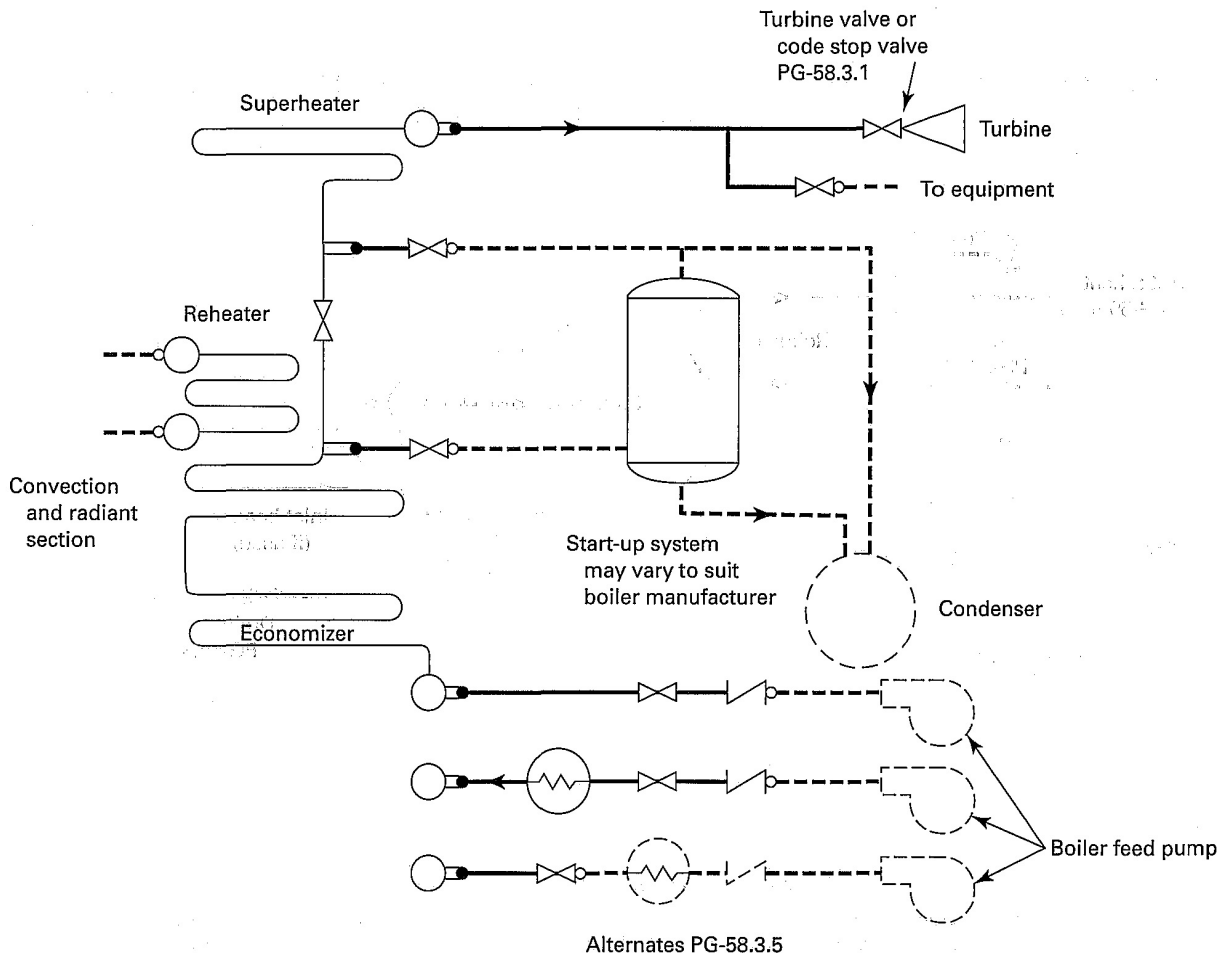

Administrative Jurisdiction & Technical Responsibility

- Boiler Proper — The ASME Boiler and Pressure Vessel Code (ASME BPVC) has total administrative jurisdiction and technical responsibility (refer to Section I Preamble)
- Boiler External Piping and Joint — The ASME BPVC has total administrative jurisdiction (mandatory certification by Code Symbol stamping, ASME Data Forms, and Authorized Inspection) of Boiler External Piping and Joint. The ASME Section Committee B31.1 has been assigned technical responsibility.
- Non-Boiler External Piping and Joint — Not Section I jurisdiction (see applicable ASME B31 Code).

FIG. PG-58.3.3 CODE JURISDICTIONAL LIMITS FOR PIPING — AN EXAMPLE OF STEAM SEPARATOR TYPE FORCED-FLOW STEAM GENERATORS WITH NO FIXED STEAM OR WATERLINE

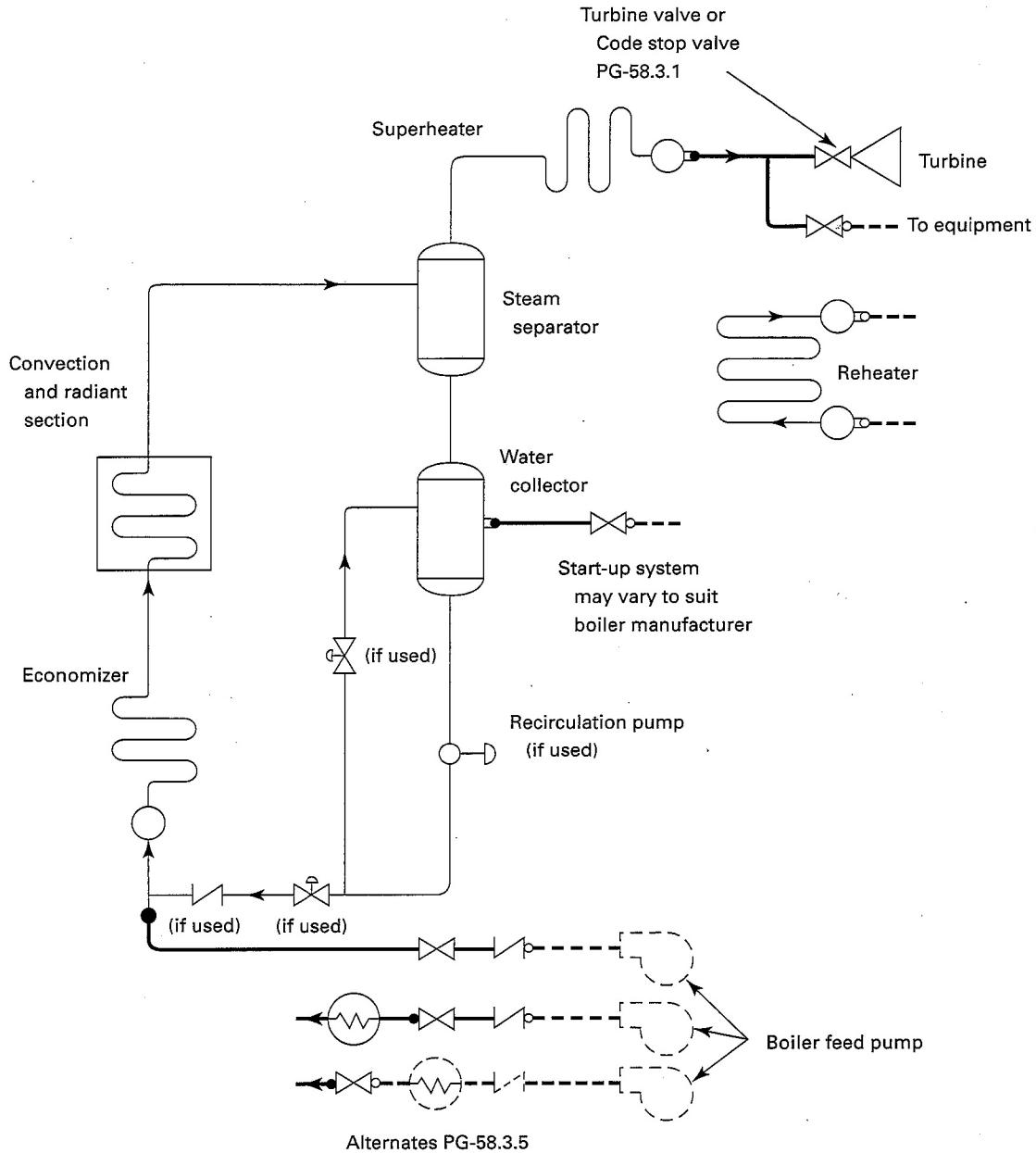

ADMINISTRATIVE JURISDICTION AND TECHNICAL RESPONSIBILITY

- Boiler Proper – The ASME Boiler and Pressure Vessel Code (ASME BPVC) has total administrative jurisdiction and technical responsibility (refer to Section I Preamble).
- Boiler External Piping and Joint – The ASME BPVC has total administrative jurisdiction (mandatory certification by Code Symbol stamping, ASME Data Forms, and Authorized Inspection) of Boiler External Piping and Joint. The ASME Section Committee B31.1 has been assigned technical responsibility.
- Non-Boiler External Piping and Joint – Not Section I jurisdiction (see applicable ASME B31 Code).

BOILER EXTERNAL PIPING AND BOILER PROPER CONNECTIONS

PG-58 OUTLETS AND EXTERNAL PIPING

PG-58.1 General. The rules of this subparagraph apply to the boiler external piping as defined in the Preamble.

PG-58.2 Boiler External Piping Connections to Boilers. All boiler external piping connected to a boiler for any purpose shall be attached to one of the types of joints listed in PG-59.1.1.1, PG-59.1.1.2, and PG-59.1.1.3.

PG-58.3 Boiler External Piping. The following defines the Code Jurisdictional Limits of the boiler external piping systems, including general requirements, valves, and inspection. The limits are also shown in Figs. PG-58.3.1 and PG-58.3.2. The materials, design, fabrication, installation, and testing shall be in accordance with ASME B31.1, Power Piping.

PG-58.3.1. The steam piping connected to the boiler drum or to the superheater outlet header shall extend up to and including the first stop valve in each connection, except as required by PG-58.3.2. In the case of a single boiler and prime mover installation, the stop valve required herein may be omitted provided the prime mover throttle valve is equipped with an indicator to show whether the valve is open or closed and is designed to withstand the required hydrostatic pressure test of the boiler.

For an isolable or separately fired superheater which discharges steam directly to a process stream, the stop valve required by this paragraph and the safety valve(s) required by PG-68 may be omitted provided the following conditions are satisfied:

- (a) The boiler is a drum-type boiler in a single-boiler installation.
- (b) The steam discharge passes through the process stream to the atmosphere with no intervening valves.
- (c) The system shall be designed so that the process stream through which the steam discharge passes cannot be obstructed in such a way as to cause the pressure in the superheater to exceed that permitted by PG-67.2, with maximum steam flow from the boiler to the superheater. Flow and pressure calculations demonstrating that the superheater will not be overpressurized under any steam flow conditions shall be documented and made available to the Inspector. These calculations shall be certified by a Professional Engineer experienced in the mechanical design of power plants.
- (d) There is no valve on the discharge side of the superheater.
- (e) Section I jurisdiction shall include the pressure parts between the superheater inlet and the outlet at:
 - (1) the first circumferential joint for welding end connections; or
 - (2) the face of the first flange in bolted flange connections; or
 - (3) the first threaded joint in that type of connection.

PG-58.3.2 When two or more boilers are connected to a common steam header, or when a single boiler is connected to a header having another steam source (e.g., a turbine extraction

line), the connection from each boiler having a manhole opening shall be fitted with two stop valves having an ample free-blow drain between them. The boiler external piping includes all piping from the boiler proper up to and including the second stop valve and the free-blow drain valve.

PG-58.3.3 The feedwater piping for all boilers, except high-temperature water boilers and forced-flow steam generators complying with PG-58.3.5, shall extend through the required stop valve and up to and including the check valve except as required by PG-58.3.4. On a single boiler-turbine unit installation the boiler feed shutoff valve may be located upstream from the boiler feed check valve.

If a feedwater heater or heaters meeting the requirements of Part PFH are installed between the required stop valve and the boiler, and are fitted with isolation and bypass valves, provisions must be made to prevent the feedwater pressure from exceeding the maximum allowable working pressure of the piping or feedwater heater, whichever is less. Control and interlock systems are permitted in order to prevent overpressure.

PG-58.3.4 When two or more boilers are fed from a common source, the piping shall be up to and including a globe or regulating valve located between the check valve required in PG-58.3.3 and the source of supply. If the regulating valve is equipped with an isolation valve and a bypass valve, the piping shall be up to and including both the isolation valve downstream from the regulating valve and the shutoff valve in the bypass.

PG-58.3.5 The feedwater piping for a forced-flow steam generator with no fixed steam and waterline may terminate up to and including the stop valve near the boiler and omitting the check valve near the boiler, provided that a check valve having a pressure rating no less than the boiler inlet design pressure is installed at the discharge of the boiler feed pump or elsewhere in the feedline between the feed pump and the feed stop valve. If the feedwater heater(s) is fitted with isolation and bypass valves, the applicable requirements of PG-58.3.3 must be met.

PG-58.3.6 The blowoff piping for all boilers, except forced-flow steam generators with no fixed steam and waterline, high-temperature water boilers, and those used for traction and/or portable purposes, when the maximum allowable working pressure exceeds 100 psi (700kPa) shall extend through and including the second valve. The blowoff piping for all traction and/or portable boilers and for forced circulation and electric boilers having a normal water content not exceeding 100 gal (380 L) are required to extend through only one valve.

PG-58.3.7 The miscellaneous piping shall include the piping for such items as drains, vents, surface-blow-off, steam and water piping for water columns, gage glasses and pressure gages, and the recirculation return line for a high-temperature water boiler. When a drain is not intended for blowoff purposes (when the boiler is under pressure) a single valve is acceptable, otherwise two valves in series are required except as permitted by PG-58.3.6.

PG-58.3.8 Welded piping in PG-58.3.1, PG-58.3.2, PG-58.3.3, PG-58.3.4, PG-58.3.5, PG-58.3.6, and PG-58.3.7 is also subject to the requirements of PG-104 for proper Code certification.

FIG. PG-59.1 TYPICAL BOILER BUSHINGS

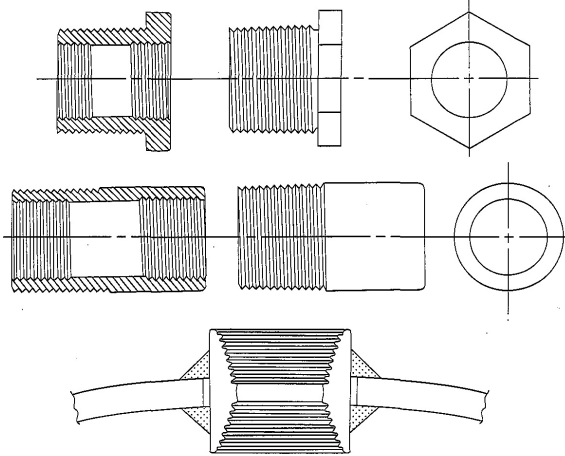

PG-59 APPLICATION REQUIREMENTS FOR THE BOILER PROPER

PG-59.1 Common to Steam, Feedwater, Blowoff, and Drain Systems

PG-59.1.1 Outlets of a boiler to which piping is to be attached for any purpose, and which piping comes within the Code requirements, shall meet the requirements of PG-39 and shall be:

PG-59.1.1.1 A tapped opening.

PG-59.1.1.2 Bolted flanged joints including those of the Van Stone type.

PG-59.1.1.3 Welding ends of the butt or socket welding type.

PG-59.1.1.4 Piping within the boiler proper may be expanded into grooved holes, seal welded if desired. Blowoff piping of firetube boilers shall be attached by threading into a tapped opening with a threaded fitting or valve at the other end if exposed to products of combustion, or by PG-59.1.1.1 or PG-59.1.1.2 if not so exposed (see PFT-49).

PG-59.1.2 Steam Mains. Provisions shall be made for the expansion and contraction of steam mains connected to boilers, by providing substantial anchorage at suitable points, so that there shall be no undue strain transmitted to the boiler. Steam reservoirs shall be used on steam mains when heavy pulsations of the steam currents cause vibration of the boiler shell plates.

PG-59.1.3 Figure PG-59.1 illustrates a typical form of connection for use on boiler shells for passing through piping such as feed, surface blowoff connections, etc., and which permits the pipes' being threaded in solid from both sides in addition to the reinforcing of the opening of the shell. The pipes shall be attached as provided in PG-59.1.1. In these and other types of boilers where both internal and external pipes making a continuous passage are employed, the boiler bushing or its equivalent shall be used.

PG-59.2 Requirements for Feedwater Connections. The feedwater shall be introduced into a boiler in such a manner that the water will not be discharged directly against surfaces exposed to gases of high temperature or to direct radiation from the fire. For pressures of 400 psi (3 MPa) or over, the feedwater inlet through the drum shall be fitted with shields, sleeves, or other suitable means to reduce the effects of temperature differentials in the shell or head. Feedwater, other than condensate

returns as provided for in PG-59.3.6, shall not be introduced through the blowoff.

PG-59.3 Requirements for Blowoffs

PG-59.3.1 A blowoff as required herein is defined as a pipe connection provided with valves located in the external piping through which the water in the boiler may be blown out under pressure, excepting drains such as are used on water columns, gage glasses, or piping to feedwater regulators, etc., used for the purpose of determining the operating condition of such equipment. Piping connections used primarily for continuous operation, such as deconcentrators on continuous blowdown systems, are not classed as blowoffs but the pipe connections and all fittings up to and including the first shutoff valve shall be equal at least to the pressure requirements for the lowest set pressure of any safety valve on the boiler drum and with the corresponding saturated-steam temperature.

PG-59.3.2 A surface blowoff connection shall not exceed NPS 2 ½ (DN 65), and the internal pipe and the terminal connection for the external pipe, when used, shall form a continuous passage, but with clearance between their ends and arranged so that the removal of either will not disturb the other. A properly designed steel bushing, similar to or the equivalent of those shown in Fig. PG-59.1, or a flanged connection shall be used.

PG-59.3.3 Each boiler except forced-flow steam generators with no fixed steam and waterline and high-temperature water boilers shall have a bottom blowoff outlet in direct connection with the lowest water space practicable for external piping conforming to PG-58.3.6.

PG-59.3.4 All waterwalls and water screens that do not drain back into the boiler, and all integral economizers, shall be equipped with outlet connections for a blowoff or drain line and conform to the requirements of PG-58.3.6 or PG-58.3.7.

PG-59.3.5 Except as permitted for miniature boilers in Part PMB, the minimum size of blowoff connections shall be NPS 1 (DN 25), and the maximum size shall be NPS 2 ½ (DN 65), except that for boilers with 100 ft² (9.3 m²) of heating surface or less, the minimum size of blowoff connections may be NPS ¾ (DN 20).

PG-59.3.6 Condensate return connections of the same size or larger than the size herein specified may be used, and the blowoff may be connected to them. In such case the blowoff shall be so located that the connection may be completely drained.

PG-59.3.7 A bottom blowoff pipe when exposed to direct furnace heat shall be protected by firebrick or other heat resisting material that is so arranged that the pipe may be inspected.

PG-59.3.8 An opening in the boiler setting for a blowoff pipe shall be arranged to provide free expansion and contraction.

PG-59.4 Requirements for Drains

PG-59.4.1 Ample drain connections shall be provided where required to permit complete drainage of all piping, superheaters, waterwalls, water screens, integral economizers, high-temperature water boilers, and all other boiler components in which water may collect. Piping shall conform to the requirements of PG-58.3.6 or PG-58.3.7.

PG-59.4.1.1 Each superheater shall be equipped with at least one drain connection so located as to most effectively provide for the proper operation of the apparatus.

PG-59.4.1.2 Each high-temperature water boiler shall have a bottom drain connection of at least NPS 1 (DN 25) in direct

connection with the lowest water space practical for external piping conforming to PG-58.3.7.

PG-59.5 Requirements for Valves and Fittings. The following requirements apply to the use of valves and fittings in the boiler proper.

PG-59.5.1 Steam Stop Valves

PG-59.5.1.1 If a shutoff valve is used between the boiler and its superheater, the safety valve capacity on the boiler shall comply with the requirements of PG-67.2 and PG-70, except as provided for in PG-59.5.1.2, no credit being taken for the safety valve on the superheater, and the superheater must be equipped with safety valve capacity as required by PG-68. A stop valve is not required at the inlet or the outlet of a reheater or separately fired superheater.

PG-59.5.1.2 When stop valves are installed in the water-steam flow path between any two sections of a forced-flow steam generator with no fixed steam and waterline, the safety valves shall satisfy the requirements of PG-67.4.4.

DESIGN AND APPLICATION

PG-60 REQUIREMENTS FOR MISCELLANEOUS PIPE, VALVES, AND FITTINGS

Piping referred to in this paragraph shall be designed in accordance with the applicable requirements of ASME B31.1.

PG-60.1 Water Level Indicators. All boilers having a fixed water level (steam and water interface) shall have at least one gage glass (a transparent device that permits visual determination of the water level). Boilers not having a fixed water level, such as forced-flow steam generators and high-temperature water boilers of the forced circulation type, are not required to have a gage glass. The lowest visible water level in a gage glass shall be at least 2 in. (50 mm) above the lowest permissible water level, as determined by the boiler Manufacturer. Electrode-type electric boilers are required to have only one gage glass, regardless of MAWP.

Gage glasses having multiple tubular sections shall have a minimum of 1 in. (25 mm) overlap of the sections in which the water level may be visible. Segmented gage glasses, such as ported or end-connected strip gages, shall be equipped to provide obvious visual discrimination between water and vapor in the individual sections.

PG-60.1.1 Boilers having a maximum allowable working pressure exceeding 400 psi (3 MPa) shall have two gage glasses. Instead of one of the two required gage glasses, two independent remote water level indicators (two discrete systems that continuously measure, transmit, and display water level) may be provided.

PG-60.1.1.1 When the water level in at least one gage glass is not readily visible to the operator in the area where control actions are initiated, either a fiber optic cable (with no electrical modification of the optical signal) or mirrors shall be provided to transfer the optical image of the water level to the control area. Alternatively, any combination of two of the following shall be provided:

- (a) an independent remote water level indicator
- (b) an independent continuous transmission and display of an image of the water level in a gage glass.

PG-60.1.1.2 When two independent remote water level indicators are in reliable operation (continuously indicating water level), the one required gage glass may be shut off, but shall be maintained in the serviceable condition.

PG-60.1.1.3 The display of a remote water level indicator shall have a clearly marked minimum water level reference at

least 2 in. (50 mm) above the lowest permissible water level, as determined by the Manufacturer.

PG-60.1.6 Each gage glass shall be fitted with a drain cock or valve having an unrestricted drain opening of not less than ¼ in. (6 mm) diameter to facilitate cleaning. When the boiler MAWP exceeds 100 psi (700 kPa), the gage glass shall be furnished with a connection to install a valved drain to a point of safe discharge.

Each gage glass shall be equipped with a top and a bottom shutoff valve of such through-flow construction as to prevent stoppage by deposits of sediments. If the bottom valve is more than 7 ft (2 m) above the floor or platform from which it is operated, the operating mechanism shall indicate by its position whether the valve is open or closed. The pressure—temperature rating of valves, fittings, and piping shall be at least equal to the boiler MAWP and the corresponding saturated-steam temperature.

Straight-run globe valves shall not be used on such connections. Automatic shutoff valves, if permitted to be used, shall conform to the requirements given in A-18.

PG-60.2 Water Columns

PG-60.2.1 A water column shall be so mounted that it will be correctly positioned, relative to the normal water level under operating conditions.

PG-60.2.3 Each water column shall be furnished with a connection of at least NPS ¾ (DN 20) to install a valved drain to a safe point of discharge.

PG-60.2.4 The design and material of a water column shall comply with the requirements of PG-8.2, PG-8.3, and PG-42.

PG-60.3 Connections.

PG-60.3.1 Gage glasses that are required by PG-60.1 shall be connected directly to the shell or drum of the boiler or to an intervening water column. When two gage glasses are required, both may be connected to a single water column.

PG-60.3.2 The lower edge of the steam connection between a water column or gage glass in the boiler shall not be below the highest visible water level in the gage glass. There shall be no sag or offset in the piping that will permit the accumulation of water.

PG-60.3.3 The upper edge of the water connection between a water column or gage glass and the boiler shall not be above the lowest visible water level in the gage glass. No part of this pipe connection shall be above the point of connection at the water column.

PG-60.3.4 Connections from the boiler to the water column shall be at least NPS 1 (DN 25). Connections for gage glasses connected directly to the boiler or to an intervening water column shall be at least NPS ½ (DN 15). Connections from the boiler to the remote level indicator shall be at least NPS ¾ (DN 20) to and including the isolation valve and from there to the remote level indicator at least ½ in. (13 mm) O.D. tubing.

PG-60.3.5 When the boiler MAWP exceeds 400 psi (3 MPa), lower connections to drums for water columns and remote level indicators shall be provided with shields, sleeves, or other suitable means to reduce the effect of temperature differentials in the shells or heads.

PG-60.3.6 The steam and water connections to a water column or a gage glass shall be readily accessible for internal inspection and cleaning. Some acceptable methods of meeting this requirement are by providing a cross or fitting with a back outlet at each right-angle turn to permit inspection and cleaning in both directions, or by using pipe bends or fittings of a type

that does not leave an internal shoulder or pocket in the pipe connection and with a radius of curvature that will permit the passage of a rotary cleaner. Screwed plug closures using threaded connections as allowed by PG-39.5.3 are acceptable means of access for this inspection and cleaning. When the boiler MAWP exceeds 400 psig (3 MPa), socket-welded plugs may be used for this purpose in lieu of screwed plugs. If the water connection to the water column has a rising bend or pocket that cannot be drained by means of the water-column drain, an additional drain shall be placed on this connection so that it may be blown off to clear any sediment from the pipe.

FIG. PG-60.3.7 Y-TYPE GLOBE VALVE

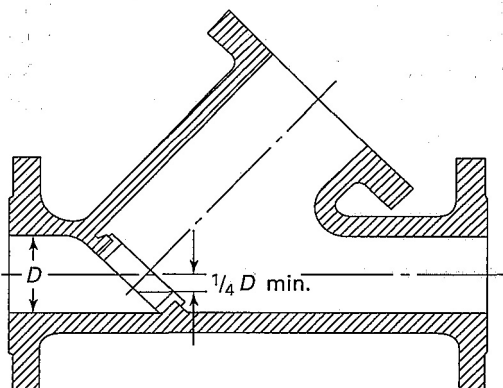

PG-60.3.7 Shutoff valves, if provided in the pipe connections between a boiler and a water column or between a boiler and the shutoff valves required for the gage glass (PG-60.1.6), shall be of such through-flow construction as to prevent stoppage by deposits of sediment and shall indicate whether they are in open or closed position of the operating mechanism.

Some examples of acceptable valves are:

- outside-screw-and-yoke type gate valve
- lever-lifting-type gate valve with permanently fastened lever
- stopcock with the plug held in place by a guard or gland
- ball valve

Such valves shall be locked or sealed open except under the following additional conditions:

- The boiler MAWP shall not exceed 250 psig (1.7 MPa).
- The boiler shall not be hand fired or fired with solid fuel not in suspension.
- Interlocks between the valve and the burner control system shall stop fuel supply and prevent firing whenever the valve between the drum and the water column is not in the fully open position.
- The minimum valve size shall be NPS 1 (DN 25).

PG-60.3.8 Except for control devices such as damper regulators and feedwater regulators, drains, steam pressure gages, or apparatus of such form as does not permit the escape of an appreciable amount of steam or water therefrom, no outlet connections shall be placed on the piping connecting a water column or gage glass to a boiler. No outlet connections shall be placed on the piping connecting a remote level indicator to the boiler or to a water column for any function other than water level indication.

PG-60.3.9 An acceptable arrangement is shown in Fig. PG-60.3.9

FIG. PG-60.3.9 TYPICAL ARRANGEMENT OF STEAM AND WATER CONNECTIONS FOR A WATER COLUMN

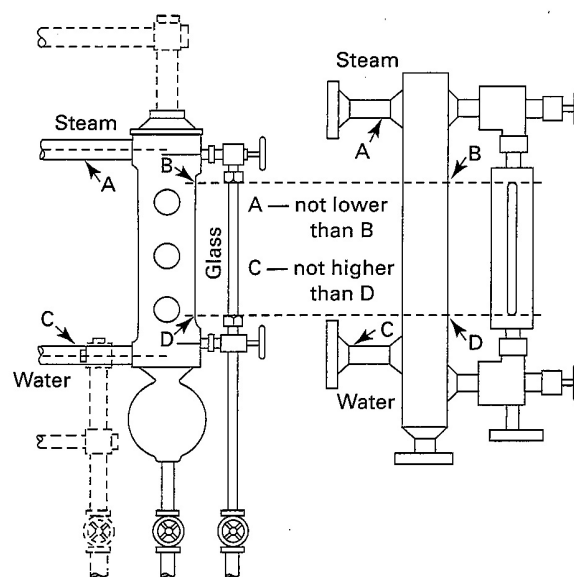

PG-60.4 Gage Cocks. Not required.

PG-60.5 Water Fronts. Each boiler fitted with a water jacketed boiler-furnace mouth protector, or similar appliance having valves on the pipes connecting them to the boiler shall have these valves locked or sealed open. Such valves, when used, shall be of the straightway type.

PG-60.6 Pressure Gages

PG-60.6.1 Each boiler shall have a pressure gage so located that it is easily readable. The pressure gage shall be installed so that it shall at all times indicate the pressure in the boiler. Each steam boiler shall have the pressure gage connected to the steam space or to the water column or its steam connection. A valve or cock shall be placed in the gage connection adjacent to the gage. An additional valve or cock may be located near the boiler providing it is locked or sealed in the open position. No other shutoff valves shall be located between the gage and the boiler. The pipe connection shall be of ample size and arranged so that it may be cleared by blowing out. For a steam boiler the gage or connection shall contain a syphon or equivalent device that will develop and maintain a water seal that will prevent steam from entering the gage tube. Pressure gage connections shall be suitable for the maximum allowable working pressure and temperature, but if the temperature exceeds 406°F (208°C), brass or copper pipe or tubing shall not be used. The connections to the boiler, except the syphon, if used, shall not be less than NPS ¼ (DN 8) but where steel or wrought iron pipe or tubing is used, they shall not be less than ½ in. (13 mm) inside diameter. The minimum size of a syphon, if used, shall be ¼ in. (6 mm) inside diameter. The dial of the pressure gage shall be graduated to approximately double the pressure at which the safety valve is set, but in no case to less than 1 ½ times this pressure.

PG-60.6.2 Each forced-flow steam generator with no fixed steam and waterline shall be equipped with pressure gages or other pressure measuring devices located as follows:

PG-60.6.2.1 At the boiler or superheater outlet (following the last section which involves absorption of heat), and

PG-60.6.2.2 At the boiler or economizer inlet (preceding any section that involves absorption of heat), and

PG-60.6.2.3 Upstream of any shutoff valve that may be used between any two sections of the heat absorbing surface.

PG-60.6.3 Each boiler shall be provided with a valve connection at least NPS ¼ (DN 8) for the exclusive purpose of attaching a test gage when the boiler is in service, so that the accuracy of the boiler pressure gage can be ascertained.

PG-60.6.4 Each high-temperature water boiler shall have a temperature gage so located and connected that it shall be easily readable. The temperature gage shall be installed so that it at all times indicates the temperature in degrees Fahrenheit (Celsius) of the water in the boiler, at or near the outlet connection.

PG-61 FEEDWATER SUPPLY

PG-61.1 Except as provided for in PG-61.2 and PG-61.4, boilers having more than 500 ft² (47 m²) of water-heating surface shall have at least two means of feeding water. Except as provided for in PG-61.3, PG-61.4, and PG-61.5, each source of feeding shall be capable of supplying water to the boiler at a pressure of 3% higher than the highest setting of any safety valve on the boiler. For boilers that are fired with solid fuel not in suspension, and for boilers whose setting or heat source can continue to supply sufficient heat to cause damage to the boiler if the feed supply is interrupted, one such means of feeding shall not be susceptible to the same interruption as the other, and each shall provide sufficient water to prevent damage to the boiler.

PG-61.2 Except as provided for in PG-61.1, a boiler fired by gaseous, liquid, or solid fuel in suspension, or heated by combustion turbine engine exhaust, may be equipped with a single means of feeding water, provided means are furnished for the shutting off of its heat input prior to the water level reaching the lowest permissible level established by PG-60.

PG-61.3 For boilers having a water-heating surface of not more than 100 ft² (9.3 m²) the feed connection to the boiler shall not be smaller than NPS ½ (DN 15). For boilers having a water-heating surface more than 100 ft² (9.3 m²) the feed connection to the boiler shall not be less than NPS ¾ (DN 20).

PG-61.4 High-temperature water boilers shall be provided with means of adding water to the boiler or system while under pressure.

PG-61.5 A forced-flow steam generator with no fixed steam and waterline shall be provided with a source of feeding capable of supplying water to the boiler at a pressure not less than the expected maximum sustained pressure at the boiler inlet, as determined by the boiler Manufacturer, corresponding to operation at maximum designed steaming capacity with maximum allowable working pressure at the superheater outlet.

OVERPRESSURE PROTECTION REQUIREMENTS

PG-67 BOILER

PG-67.1 Each boiler shall have at least one pressure relief valve and if it has more than 500 ft² (47 m²) of bare tube water-heating surface, or if an electric boiler has a power input more than 1,100 kW, it shall have two or more pressure relief valves. For a boiler with combined bare tube and extended water-heating surface exceeding 500 ft² (47 m²), two or more pressure relief valves are required only if the design steam generating capacity of the boiler exceeds 4,000 lb/hr (1 800 kg/hr). Organic fluid vaporizer generators require special consideration as given in Part PVG.

PG-67.2 The pressure relief valve capacity for each boiler (except as noted in PG-67.4) shall be such that the pressure relief valve, or valves will discharge all the steam that can be generated by the boiler without allowing the pressure to rise more than 6% above the highest pressure at which any valve is set and in no case to more than 6% above the maximum allowable working pressure.

PG-67.2.1 The minimum required relieving capacity of the pressure relief valves for all types of boilers shall be not less than the maximum designed steaming capacity at the MAWP of the boiler, as determined by the Manufacturer and shall be based on the capacity of all the fuel burning equipment as limited by other boiler functions.

PG-67.2.2 The minimum required relieving capacity for a waste heat boiler shall be determined by the Manufacturer. When auxiliary firing is to be used in combination with waste heat recovery, the maximum output as determined by the boiler Manufacturer shall include the effect of such firing in the total required capacity. When auxiliary firing is to be used in place of waste heat recovery, the minimum required relieving capacity shall be based on auxiliary firing or waste heat recovery, whichever is higher.

PG-67.2.3 The minimum required relieving capacity for electric boilers shall be in accordance with PEB-15.

PG-67.2.4 The minimum required relieving capacity in lb/hr (kg/hr) for a high-temperature water boiler shall be determined by dividing the maximum output in Btu/hr (W) at the boiler nozzle, produced by the highest heating value fuel for which the boiler is designed, by 1,000 (646).

PG-67.2.5 The minimum required relieving capacity for organic fluid vaporizers shall be in accordance with PVG-12. The minimum required relieving capacity for miniature boilers shall be in accordance with PMB-15.

PG-67.2.6 Any economizer that may be shut off from the boiler, thereby permitting the economizer to become a fired pressure vessel, shall have one or more pressure relief valves with a total discharge capacity, in lb/hr (kg/hr), calculated from the maximum expected heat absorption in Btu/hr (W), as determined by the Manufacturer, divided by 1,000 (646). This absorption shall be stated in the stamping (PG-106.4). For overpressure conditions where the fluid relieved is water, the discharge capacity of the pressure relief valve, or valves shall be sufficient to prevent the pressure from exceeding the limits of PG-67.2.

PG-67.2.7 The steam generated when all pressure relief valves are relieving at full lift on a boiler that has a steam-generating surface located downstream in the gas stream of a superheater and/or reheater surface may exceed the maximum designed steaming capacity at the MAWP of the boiler. The Manufacturer shall address this by one of the following methods:

PG-67.2.7.1 The minimum required relieving capacity of the pressure relief valves shall not be less than the steam that may be generated with all pressure relief valves relieving at full lift. For boilers that use auxiliary firing in combination with the primary heat source, the Manufacturer shall include the effect of such firing in the total required capacity.

PG-67.2.7.2 The minimum required relieving capacity of the pressure relief valves shall not be less than the maximum designed steaming capacity at the MAWP of the boiler, and the boiler shall be provided with controls responsive to steam pressure, which include not less than the following:

- (a) a control that reduces that total heat input to the boiler

such that the steam generated does not exceed the maximum designed steaming capacity at the MAWP of the boiler

(b) a control that trips the heat input to the boiler if the pressure reaches 106% of the MAWP of the boiler.

PG-67.3 One or more pressure relief valves on the boiler proper shall be set at or below the maximum allowable working pressure (except as noted in PG-67.4). If additional valves are used the highest pressure setting shall not exceed the maximum allowable working pressure by more than 3%. The complete range of pressure settings of all the saturated-steam pressure re-

lief valves on a boiler shall not exceed 10% of the highest pressure to which any valve is set. Pressure setting of pressure relief valves on high-temperature water boilers⁸ may exceed this 10% range. Economizer pressure relief devices required by PG-67.2.6 shall be set as above using the MAWP of the economizer.

⁸ Pressure relief valves in hot water service are more susceptible to damage and subsequent leakage, than pressure relief valves relieving steam. It is recommended that the maximum allowable working pressure of the boiler and the pressure relief valve setting for high-temperature water boilers be selected substantially higher than the desired operating pressure so as to minimize the times the pressure relief valve must lift.

FIG. PG-67.4 REQUIREMENTS FOR PRESSURE RELIEF FORCED-FLOW STEAM GENERATOR

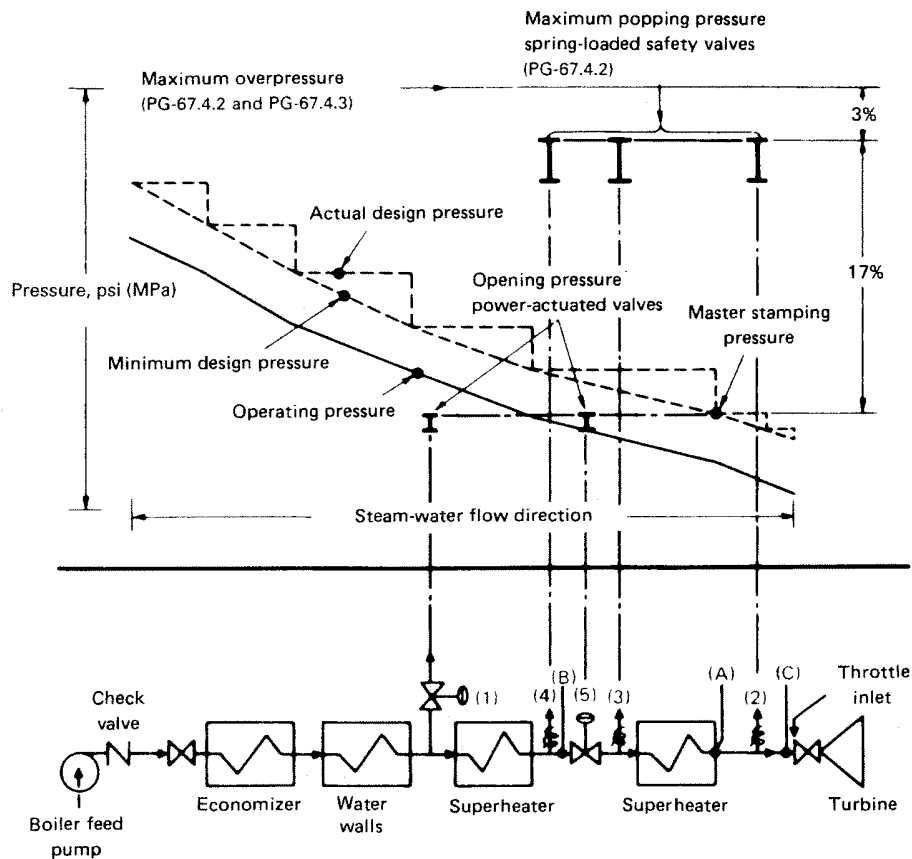
**Pressure**

- (A) = master stamping (PG-106.3)
 (B) = component design at inlet to stop valve (5) (PG-67.4.4.1)
 (C) = turbine throttle inlet (ANSI/ASME B31.1, paragraph 122.1.2, A.4)

Pressure Relief Valves

- (1) = power actuated (PG-67.4.1)
 (2), (3), and (4) = spring loaded safety (PG-67.4.2)
 (5) = superheater stop (PG-67.4.4)

Relief Valve Flow Capacity (minimum, based on rated capacity of boiler)

- (1) = 10 – 30% (PG-67.4.1)
 (2) = minimum of one valve (PG-68.1)
 (2) + (3) when downstream to stop valve (5) = that required for independently fired superheaters (PG-68.3)
 (2) + (3) + (4) = 100% – (1) (PG-67.4.2)

Relief Valve Opening Pressure (maximum)

- (1) = (A), and (B) when there is stop valve (5) (PG-67.4.1)
 (2), (3), and (4) = (A) + 17% (PG-67.4.2)
 (5) = (A) (PG-67.4.1)

Alternate Requirements for Safety Valves**Relief Valve Flow Capacity (minimum, based on rated capacity of boiler)**

- (1) = 10 – 30% (PG-67.4.1)
 (2) = one valve minimum (PG-68.1)
 (2) + (3) when downstream to stop valve (5) = that required for independently fired superheaters (PG-68.3)
 (4) = 10% total with minimum of 2 valves when there is a stop valve (5) (PG-67.5.3.3)
 (2) + (4) = 10% with minimum of 2 valves when there is no stop valve (5) (PG-67.4.3.3)

Relief Valve Opening Pressure (maximum)

- (1) = (A), and (B) when there is stop valve (5) (PG-67.4.1)
 (2), (3), and (4) = (A) + 20% (PG-67.4.3.3)
 (5) = (A) (PG-67.4.1)

Automatic Pressure Controls (PG-67.4.3)

- (a) at (C) for normal operation under load (PG-67.4.3.2.1)
 (b) at (A) + 10% to override control (a) (PG-67.4.3.2.2)
 (c) at (A) + 20% to shut off flow of fuel and feedwater (PG-67.4.3.2.3)
 (d) safety valves at (4) to shut off flow of fuel and feedwater by "fail-safe" power circuit (PG-67.4.3.4)

PG-67.4 For a forced-flow steam generator with no fixed steam and waterline (Fig. PG-6704), equipped with automatic controls and protective interlocks responsive to steam pressure, pressure relief valves may be provided in accordance with the above paragraphs or the following protection against overpressure shall be provided:

PG-67.4.1 One or more power-actuated pressure relieving valves⁹ shall be provided in direct communication with the boiler when the boiler is under pressure and shall receive a control impulse to open when the maximum allowable working pressure at the superheater outlet, as shown in the master stamping (PG-106.3), is exceeded. The total combined relieving capacity of the power-actuated relieving valves shall be not less than 10% of the maximum design steaming capacity of the boiler under any operating condition as determined by the Manufacturer. The valve or valves shall be located in the pressure part system where they will relieve the overpressure.

⁹The power-actuated pressure relieving valve is one whose movements to open or close are fully controlled by a source of power (electricity, air, steam, or hydraulic). The valve may discharge to atmosphere or to a container at lower pressure. The discharge capacity may be affected by the downstream conditions, and such effects shall be taken into account. If the power-actuated pressure relieving valves are also positioned in response to other control signals, the control impulse to prevent overpressure shall be responsive only to pressure and shall override any other control function.

An isolating stop valve of the outside-screw-and-yoke or ball type may be installed between the power-actuated pressure relieving valve and the boiler to permit repairs provided an alternate power-actuated pressure relieving valve of the same capacity is so installed as to be in direct communication with the boiler in accordance with the requirements of this paragraph.

The isolating stop valve port area shall at least equal the area of the inlet of the power-actuated pressure relieving valve. If the isolating stop valve is of the ball type, the valve shall include a means to clearly identify whether the valve is in the open or closed position. If the isolating stop valve is power actuated (air, motor, hydraulic, etc.), a manual override mechanism shall be provided.

Power-actuated pressure relieving valves discharging to intermediate pressure and incorporated into bypass and/or startup circuits by the boiler Manufacturer need not be capacity certified. Instead, they shall be marked by the valve manufacturer with a capacity rating at a set of specified inlet pressure and temperature conditions. Power-actuated pressure relieving valves discharging directly to atmosphere shall be capacity certified. This capacity certification shall be conducted in accordance with the provisions of PG-69.3. The valves shall be marked in accordance with the provisions of PG-69.4.

PG-67.4.2 Pressure relief valves shall be provided, having a total combined relieving capacity, including that of the power-actuated pressure relieving capacity installed under PG-67.4.1, of not less than 100% of the maximum designed steaming capacity of the boiler, as determined by the Manufacturer, except the alternate provisions of PG-67.4.3 are satisfied. In this total, no credit in excess of 30% of the total required relieving capacity shall be allowed for the power-actuated pressure relieving valves actually installed. Any or all of the pressure relief valves may be set above the maximum allowable working pressure of the parts to which they are connected, but the set pressures shall be such that when all of these valves (together with the power-actuated pressure relieving valves) are in operation the pressure will not rise more than 20% above the maximum allowable working pressure of any part of the boiler, except for the steam piping between the boiler and the prime mover.

PG-67.4.3 The total installed capacity of spring loaded safety valves may be less than the requirements of PG-67.4.2 provided all of the following conditions are met.

PG-67.4.3.1 The boiler shall be of no less steaming capacity than 1,000,000 lb/hr (450 000 kg/hr) and installed in a unit system for power generation (i.e., a single boiler supplying a single turbine-generator unit).

PG-67.4.3.2 The boiler shall be provided with automatic devices, responsive to variations in steam pressure, which include not less than all the following:

PG-67.4.3.2.1 A control capable of maintaining steam pressure at the desired operating level and of modulating firing rates and feedwater flow in proportion to a variable steam output.

PG-67.4.3.2.2 A control that overrides PG-67.4.3.2.1 by reducing the fuel rate and feedwater flow when the steam pressure exceeds the maximum allowable working pressure as shown in the master stamping (PG-106.3) by 10%; and

PG-67.4.3.2.3 A direct-acting overpressure-trip-actuating mechanism, using an independent pressure sensing device, that will stop the flow of fuel and feedwater to the boiler, at a pressure higher than the set pressure of PG-67.4.3.2.2, but less than 20% above the maximum allowable working pressure as shown in the master stamping (PG-106.3).

PG-67.4.3.3 There shall be not less than two pressure relief valves and the total rated relieving capacity of the pressure relief valves shall be not less than 10% of the maximum designed steaming capacity of the boiler as determined by the Manufacturer. These pressure relief valves may be set above the maximum allowable working pressure of the parts to which they are connected but shall be set such that the valves will lift at a pressure no higher than 20% above the maximum allowable working pressure as shown in the master stamping (PG-106.3).

PG-67.4.3.4 At least two of these pressure relief valves shall be equipped with a device that directly transmits the valve stem lift action to controls that will stop the flow of fuel and feedwater to the boiler. The control circuitry to accomplish this shall be arranged in a "fail-safe" manner (see Note).

NOTES: "Fail-safe" shall mean a circuitry arranged as either of the following:

(a) *Energize to trip:* There shall be at least two separate and independent trip circuits served by two power sources, to initiate and perform the trip action. One power source shall be a continuously charged DC battery. The second source shall be an AC-to-DC converter connected to the DC system to charge the battery and capable of performing the trip action. The trip circuits shall be continuously monitored for availability.

It is not mandatory to duplicate the mechanism that actually stops the flow of fuel and feedwater.

(b) *De-energize to trip:* If the circuits are arranged in such a way that a continuous supply of power is required to keep the circuits closed and operating and such that any interruption of power supply will actuate the trip mechanism, then a single trip circuit and single power supply will be enough to meet the requirements of this subparagraph.

PG-67.4.3.5 The power supply for all controls and devices required by PG-67.4.3 shall include at least one source contained within the same plant as the boiler and which is arranged to actuate the controls and devices continuously in the event of failure or interruption of any other power sources.

PG-67.4.4 When stop valves are installed in the water-steam flow path between any two sections of a forced-flow steam generator with no fixed steam and waterline:

PG-67.4.4.1 The power-actuated pressure relieving valve(s) required by PG-67.4.1 shall also receive a control impulse to open when the maximum allowable working pressure of the component, having the lowest pressure upstream to the stop valve, is exceeded; and

PG-67.4.4.2 The pressure relief valves shall be located to provide the pressure protection requirements in PG-67.4.2 or PG-67.4.3.

PG-67.4.5 A reliable pressure-recording device shall always be in service and records kept to provide evidence of conformity to the above requirements.

PG-67.5 The coefficient of discharge of pressure relief valves shall be determined by actual steam flow measurements at a pressure not more than 3% above the pressure at which the valve is set to relieve and when adjusted for blowdown in accordance with PG-69.1.4. The valves shall be credited with capacities as determined by the provisions of PG-69.2.

Pressure relief valves may be used that give any opening up to the full discharge capacity of the area of the opening of the inlet of the valve, provided the movement of a steam pressure relief valve is such as not to induce lifting of water in the boiler.

For high-temperature water boilers pressure relief valves shall be used. Such valves shall have a closed bonnet. In addition the pressure relief valves shall be capable of satisfactory operation when relieving water at the saturation temperature corresponding to the pressure at which the valve is set to blow.

PG-68 SUPERHEATER AND REHEATER

PG-68.1 Except as permitted in PG-58.3.1, every attached superheater shall have one or more pressure relief valves in the steam flow path between the superheater outlet and the first stop valve. The location shall be suitable for the service intended and shall provide the overpressure protection required. The pressure drop upstream of each pressure relief valve shall be considered in the determination of set pressure and relieving capacity of that valve. If the superheater outlet header has a full, free steam passage from end to end and is so constructed that steam is supplied to it at practically equal intervals throughout its length so that there is a uniform flow of steam through the superheater tubes and the header, the pressure relief valve, or valves, may be located anywhere in the length of the header.

PG-68.2 The discharge capacity of the pressure relief valve, or valves, on an attached superheater may be included in determining the number and size of the pressure relief valves for the boiler, provided there are no intervening valves between the superheater pressure relief valve and the boiler, and provided the discharge capacity of the pressure relief valve, or valves, on the boiler, as distinct from the superheater is at least 75% of the aggregate valve capacity required.

PG-68.3 Every isolable superheater that may be shut off from the boiler and permit the superheater to become a fired

pressure vessel and all nonintegral separately fired superheaters shall have one or more pressure relief valves having a discharge capacity equal to 6 lb/ft² (29 kg/m²) of steam per hour, using the superheater surface measured on the side exposed to the hot gases. As an alternative the Manufacturer may also calculate the minimum pressure relief valve discharge capacity in lb (kg) of steam per hour from the maximum expected heat absorption (as determined by the Manufacturer) in Btu/hr (W), divided by 1,000 (646). In the case of electrically heated superheaters, the pressure relief valve capacity shall be based upon 3 ½ lb (1.6 kg)/hr/kW input. The number of pressure relief valves installed shall be such that the total capacity is at least equal to that required. Pressure relief valves for separately fired superheaters shall be located in accordance with the rules of PG-68.1 and the mounting rules of PG-71.

PG-68.4 Every reheater shall have one or more pressure relief valves, such that the total relieving capacity is at least equal to the maximum steam flow for which the heater is designed. The capacity of the reheater pressure relief valves shall not be included in the required relieving capacity for the boiler and superheater.

One or more pressure relief valves with a combined relieving capacity not less than 15% of the required total shall be located along the steam flow path between the reheater outlet and the first stop valve. The pressure drop upstream of the pressure relief valves on the outlet side of the reheater shall be considered in determining their set pressure.

PG-68.5 A soot blower connection may be attached to the same outlet from the superheater or reheater that is used for the pressure relief valve connection.

PG-68.6 Every pressure relief valve used on a superheater or reheater discharging superheated steam at a temperature over 450°F (230°C) shall have a casing, including the base, body, and, if applicable, bonnet and spindle, of steel, steel alloy, or equivalent heat-resisting material.

The pressure relief valve shall have a flanged inlet connection, or a weld-end inlet connection. It shall have the seat and disk of suitable heat erosive and corrosive resisting material, and the spring of direct spring-loaded safety valves shall be fully exposed outside of the valve casing so that it shall be protected from contact with the escaping steam.

PG-68.7 The capacity of a pressure relief valve on superheated steam shall be calculated by multiplying the capacity determined in accordance with PG-69.2 by the appropriate superheat correction factor K_{sh} , from Table PG-68.7.

TABLE PG-68.7
SUPERHEAT CORRECTION FACTOR, K_{sh}

Flowing Pressure (psia)	Superheat Correction Factor, K_{sh} , Total Temperature, °F, of Superheated Steam																
	400	450	500	550	600	650	700	750	800	850	900	950	1000	1050	1100	1150	1200
50	0.987	0.957	0.930	0.905	0.882	0.861	0.841	0.823	0.805	0.789	0.774	0.759	0.745	0.732	0.719	0.708	0.696
100	0.998	0.963	0.935	0.909	0.885	0.864	0.843	0.825	0.807	0.790	0.775	0.760	0.746	0.733	0.720	0.708	0.697
150	0.984	0.970	0.940	0.913	0.888	0.866	0.846	0.826	0.808	0.792	0.776	0.761	0.747	0.733	0.721	0.709	0.697
200	0.979	0.977	0.945	0.917	0.892	0.869	0.848	0.828	0.810	0.793	0.777	0.762	0.748	0.734	0.721	0.709	0.698
250	...	0.972	0.951	0.921	0.895	0.871	0.850	0.830	0.812	0.794	0.778	0.763	0.749	0.735	0.722	0.710	0.698
300	...	0.968	0.957	0.926	0.898	0.874	0.852	0.832	0.813	0.796	0.780	0.764	0.750	0.736	0.723	0.710	0.699
350	...	0.968	0.963	0.930	0.902	0.877	0.854	0.834	0.815	0.797	0.781	0.765	0.750	0.736	0.723	0.711	0.699
400	0.963	0.935	0.906	0.880	0.857	0.836	0.816	0.798	0.782	0.766	0.751	0.737	0.724	0.712	0.700
450	0.961	0.940	0.909	0.883	0.859	0.838	0.818	0.800	0.783	0.767	0.752	0.738	0.725	0.712	0.700
500	0.961	0.946	0.914	0.886	0.862	0.840	0.820	0.801	0.784	0.768	0.753	0.739	0.725	0.713	0.701
550	0.962	0.952	0.918	0.889	0.864	0.842	0.822	0.803	0.785	0.769	0.754	0.740	0.726	0.713	0.701
600	0.964	0.958	0.922	0.892	0.867	0.844	0.823	0.804	0.787	0.770	0.755	0.740	0.727	0.714	0.702
650	0.968	0.958	0.927	0.896	0.869	0.846	0.825	0.806	0.788	0.771	0.756	0.741	0.728	0.715	0.702
700	0.958	0.931	0.899	0.872	0.848	0.827	0.807	0.789	0.772	0.757	0.742	0.728	0.715	0.703
750	0.958	0.936	0.903	0.875	0.850	0.828	0.809	0.790	0.774	0.758	0.743	0.729	0.716	0.703
800	0.960	0.942	0.906	0.878	0.852	0.830	0.810	0.792	0.774	0.759	0.744	0.730	0.716	0.704
850	0.962	0.947	0.910	0.880	0.855	0.832	0.812	0.793	0.776	0.760	0.744	0.730	0.717	0.704
900	0.965	0.953	0.914	0.883	0.857	0.834	0.813	0.794	0.777	0.760	0.745	0.731	0.718	0.705
950	0.969	0.958	0.918	0.886	0.860	0.836	0.815	0.796	0.778	0.761	0.746	0.732	0.718	0.705
1000	0.974	0.959	0.923	0.890	0.862	0.838	0.816	0.797	0.779	0.762	0.747	0.732	0.719	0.706
1050	0.960	0.927	0.893	0.864	0.840	0.818	0.798	0.780	0.763	0.748	0.733	0.719	0.707
1100	0.962	0.931	0.896	0.867	0.842	0.820	0.800	0.781	0.764	0.749	0.734	0.720	0.707
1150	0.964	0.936	0.899	0.870	0.844	0.821	0.801	0.782	0.765	0.749	0.735	0.721	0.708
1200	0.966	0.941	0.903	0.872	0.846	0.823	0.802	0.784	0.766	0.750	0.735	0.721	0.708
1250	0.969	0.946	0.906	0.875	0.848	0.825	0.804	0.785	0.767	0.751	0.736	0.722	0.709
1300	0.973	0.952	0.910	0.878	0.850	0.826	0.805	0.786	0.768	0.752	0.737	0.723	0.709
1350	0.977	0.958	0.914	0.880	0.852	0.828	0.807	0.787	0.769	0.753	0.737	0.723	0.710
1400	0.982	0.963	0.918	0.883	0.854	0.830	0.808	0.788	0.770	0.754	0.738	0.724	0.710
1450	0.987	0.968	0.922	0.886	0.857	0.832	0.809	0.790	0.771	0.754	0.739	0.724	0.711
1500	0.993	0.970	0.926	0.889	0.859	0.833	0.811	0.791	0.772	0.755	0.740	0.725	0.711
1550	0.972	0.930	0.892	0.861	0.835	0.812	0.792	0.773	0.756	0.740	0.726	0.712
1600	0.973	0.934	0.894	0.863	0.836	0.813	0.792	0.774	0.756	0.740	0.726	0.712
1650	0.973	0.936	0.895	0.863	0.836	0.812	0.791	0.772	0.755	0.739	0.724	0.710
1700	0.973	0.938	0.895	0.863	0.835	0.811	0.790	0.771	0.754	0.738	0.723	0.709
1750	0.974	0.940	0.896	0.862	0.835	0.810	0.789	0.770	0.752	0.736	0.721	0.707
1800	0.975	0.942	0.897	0.862	0.834	0.810	0.788	0.768	0.751	0.735	0.720	0.705
1850	0.976	0.944	0.897	0.862	0.833	0.809	0.787	0.767	0.749	0.733	0.718	0.704
1900	0.977	0.946	0.898	0.862	0.832	0.807	0.785	0.766	0.748	0.731	0.716	0.702
1950	0.979	0.949	0.898	0.861	0.832	0.806	0.784	0.764	0.746	0.729	0.714	0.700
2000	0.982	0.952	0.899	0.861	0.831	0.805	0.782	0.762	0.744	0.728	0.712	0.698
2050	0.985	0.954	0.899	0.860	0.830	0.804	0.781	0.761	0.742	0.726	0.710	0.696
2100	0.988	0.956	0.900	0.860	0.828	0.802	0.779	0.759	0.740	0.724	0.708	0.694
2150	0.956	0.900	0.859	0.827	0.801	0.778	0.757	0.738	0.722	0.706	0.692
2200	0.955	0.901	0.859	0.826	0.799	0.776	0.755	0.736	0.720	0.704	0.690
2250	0.954	0.901	0.858	0.825	0.797	0.774	0.753	0.734	0.717	0.702	0.687
2300	0.953	0.901	0.857	0.823	0.795	0.772	0.751	0.732	0.715	0.699	0.685
2350	0.952	0.902	0.856	0.822	0.794	0.769	0.748	0.729	0.712	0.697	0.682
2400	0.952	0.902	0.855	0.820	0.791	0.767	0.746	0.727	0.710	0.694	0.679
2450	0.951	0.902	0.854	0.818	0.789	0.765	0.743	0.724	0.707	0.691	0.677
2500	0.951	0.902	0.852	0.816	0.787	0.762	0.740	0.721	0.704	0.688	0.674
2550	0.951	0.902	0.851	0.814	0.784	0.759	0.738	0.718	0.701	0.685	0.671
2600	0.951	0.903	0.849	0.812	0.782	0.756	0.735	0.715	0.698	0.682	0.664
2650	0.952	0.903	0.848	0.809	0.779	0.754	0.731	0.712	0.695	0.679	0.664
2700	0.952	0.903	0.846	0.807	0.776	0.750	0.728	0.708	0.691	0.675	0.661
2750	0.953	0.903	0.844	0.804	0.773	0.747	0.724	0.705	0.687	0.671	0.657
2800	0.956	0.903	0.842	0.801	0.769	0.743	0.721	0.701	0.684	0.668	0.653
2850	0.959	0.902	0.839	0.798	0.766	0.739	0.717	0.697	0.679	0.663	0.649
2900	0.963	0.902	0.836	0.794	0.762	0.735	0.713	0.693	0.675	0.659	0.645
2950	0.902	0.834	0.790	0.758	0.731	0.708	0.688	0.671	0.655	0.640
3000	0.901	0.831	0.786	0.753	0.726	0.704	0.684	0.666	0.650	0.635
3050	0.899	0.827	0.782	0.749	0.722	0.699	0.679	0.661	0.645	0.630
3100	0.896	0.823	0.777	0.744	0.716	0.693	0.673	0.656	0.640	0.625
3150	0.894	0.819	0.772	0.738	0.711	0.688	0.668	0.650	0.634	0.620
3200	0.889	0.815	0.767	0.733	0.705	0.682	0.662	0.644	0.628	0.614

TABLE PG-68.7M
SUPERHEAT CORRECTION FACTOR, K_{sh}

Flowing Pressure (MPa)	Superheat Correction Factor, K_{sh} Total Temperature, °C, of Superheated Steam																	
	205	225	250	275	300	325	350	375	400	425	450	475	500	525	550	575	600	625
0.50	0.991	0.968	0.942	0.919	0.896	0.876	0.857	0.839	0.823	0.807	0.792	0.778	0.765	0.752	0.74	0.728	0.717	0.706
0.75	0.995	0.972	0.946	0.922	0.899	0.878	0.859	0.841	0.824	0.808	0.793	0.779	0.766	0.753	0.74	0.729	0.717	0.707
1.00	0.985	0.973	0.95	0.925	0.902	0.88	0.861	0.843	0.825	0.809	0.794	0.78	0.766	0.753	0.741	0.729	0.718	0.707
1.25	0.981	0.976	0.954	0.928	0.905	0.883	0.863	0.844	0.827	0.81	0.795	0.781	0.767	0.754	0.741	0.729	0.718	0.707
1.50	0.957	0.932	0.907	0.885	0.865	0.846	0.828	0.812	0.796	0.782	0.768	0.755	0.742	0.73	0.718	0.708
1.75	0.959	0.935	0.91	0.887	0.866	0.847	0.829	0.813	0.797	0.782	0.769	0.756	0.743	0.731	0.719	0.708
2.00	0.96	0.939	0.913	0.889	0.868	0.849	0.831	0.814	0.798	0.784	0.769	0.756	0.744	0.731	0.72	0.708
2.25	0.963	0.943	0.916	0.892	0.87	0.85	0.832	0.815	0.799	0.785	0.77	0.757	0.744	0.732	0.72	0.709
2.50	0.946	0.919	0.894	0.872	0.852	0.834	0.816	0.8	0.785	0.771	0.757	0.744	0.732	0.72	0.71
2.75	0.948	0.922	0.897	0.874	0.854	0.835	0.817	0.801	0.786	0.772	0.758	0.745	0.733	0.721	0.71
3.00	0.949	0.925	0.899	0.876	0.855	0.837	0.819	0.802	0.787	0.772	0.759	0.746	0.733	0.722	0.71
3.25	0.951	0.929	0.902	0.879	0.857	0.838	0.82	0.803	0.788	0.773	0.759	0.746	0.734	0.722	0.711
3.50	0.953	0.933	0.905	0.881	0.859	0.84	0.822	0.804	0.789	0.774	0.76	0.747	0.734	0.722	0.711
3.75	0.956	0.936	0.908	0.883	0.861	0.841	0.823	0.806	0.79	0.775	0.761	0.748	0.735	0.723	0.711
4.00	0.959	0.94	0.91	0.885	0.863	0.842	0.824	0.807	0.791	0.776	0.762	0.748	0.735	0.723	0.712
4.25	0.961	0.943	0.913	0.887	0.864	0.844	0.825	0.808	0.792	0.776	0.762	0.749	0.736	0.724	0.713
4.50	0.944	0.917	0.89	0.866	0.845	0.826	0.809	0.793	0.777	0.763	0.749	0.737	0.725	0.713
4.75	0.946	0.919	0.892	0.868	0.847	0.828	0.81	0.793	0.778	0.764	0.75	0.737	0.725	0.713
5.00	0.947	0.922	0.894	0.87	0.848	0.829	0.811	0.794	0.779	0.765	0.751	0.738	0.725	0.714
5.25	0.949	0.926	0.897	0.872	0.85	0.83	0.812	0.795	0.78	0.765	0.752	0.738	0.726	0.714
5.50	0.952	0.93	0.899	0.874	0.851	0.831	0.813	0.797	0.78	0.766	0.752	0.739	0.727	0.714
5.75	0.954	0.933	0.902	0.876	0.853	0.833	0.815	0.798	0.782	0.767	0.753	0.739	0.727	0.715
6.00	0.957	0.937	0.904	0.878	0.855	0.834	0.816	0.798	0.783	0.768	0.753	0.74	0.727	0.716
6.25	0.96	0.94	0.907	0.88	0.856	0.836	0.817	0.799	0.783	0.768	0.754	0.74	0.728	0.716
6.50	0.964	0.944	0.91	0.882	0.859	0.837	0.818	0.801	0.784	0.769	0.754	0.741	0.729	0.716
6.75	0.966	0.946	0.913	0.885	0.86	0.839	0.819	0.802	0.785	0.769	0.755	0.742	0.729	0.717
7.00	0.947	0.916	0.887	0.862	0.84	0.82	0.802	0.786	0.77	0.756	0.742	0.729	0.717	
7.25	0.949	0.919	0.889	0.863	0.842	0.822	0.803	0.787	0.771	0.756	0.743	0.73	0.717	
7.50	0.951	0.922	0.891	0.865	0.843	0.823	0.805	0.788	0.772	0.757	0.744	0.73	0.718	
7.75	0.953	0.925	0.893	0.867	0.844	0.824	0.806	0.788	0.772	0.758	0.744	0.731	0.719	
8.00	0.955	0.928	0.896	0.869	0.846	0.825	0.806	0.789	0.773	0.758	0.744	0.732	0.719	
8.25	0.957	0.932	0.898	0.871	0.847	0.827	0.807	0.79	0.774	0.759	0.745	0.732	0.719	
8.50	0.96	0.935	0.901	0.873	0.849	0.828	0.809	0.791	0.775	0.76	0.746	0.732	0.72	
8.75	0.963	0.939	0.903	0.875	0.85	0.829	0.81	0.792	0.776	0.76	0.746	0.733	0.721	
9.00	0.966	0.943	0.906	0.877	0.852	0.83	0.811	0.793	0.776	0.761	0.747	0.734	0.721	
9.25	0.97	0.947	0.909	0.879	0.853	0.832	0.812	0.794	0.777	0.762	0.747	0.734	0.721	
9.50	0.973	0.95	0.911	0.881	0.855	0.833	0.813	0.795	0.778	0.763	0.748	0.734	0.722	
9.75	0.977	0.954	0.914	0.883	0.857	0.834	0.814	0.796	0.779	0.763	0.749	0.735	0.722	
10.00	0.981	0.957	0.917	0.885	0.859	0.836	0.815	0.797	0.78	0.764	0.749	0.735	0.722	
10.25	0.984	0.959	0.92	0.887	0.86	0.837	0.816	0.798	0.78	0.764	0.75	0.736	0.723	
10.50	0.961	0.923	0.889	0.862	0.838	0.817	0.799	0.781	0.765	0.75	0.737	0.723		
10.75	0.962	0.925	0.891	0.863	0.839	0.818	0.799	0.782	0.766	0.751	0.737	0.724		
11.00	0.963	0.928	0.893	0.865	0.84	0.819	0.8	0.782	0.766	0.751	0.737	0.724		
11.25	0.964	0.93	0.893	0.865	0.84	0.819	0.799	0.781	0.765	0.75	0.736	0.723		
11.50	0.964	0.931	0.894	0.865	0.84	0.818	0.798	0.78	0.764	0.749	0.735	0.722		
11.75	0.965	0.932	0.894	0.865	0.839	0.817	0.797	0.78	0.763	0.748	0.734	0.721		
12.00	0.966	0.933	0.894	0.864	0.839	0.817	0.797	0.779	0.762	0.747	0.733	0.719		
12.25	0.967	0.935	0.895	0.864	0.839	0.816	0.796	0.778	0.761	0.746	0.732	0.718		
12.50	0.967	0.936	0.896	0.864	0.838	0.816	0.796	0.777	0.76	0.745	0.731	0.717		
12.75	0.968	0.937	0.896	0.864	0.838	0.815	0.795	0.776	0.759	0.744	0.729	0.716		
13.00	0.969	0.939	0.896	0.864	0.837	0.814	0.794	0.775	0.758	0.743	0.728	0.715		
13.25	0.971	0.94	0.897	0.864	0.837	0.813	0.792	0.774	0.757	0.741	0.727	0.713		
13.50	0.972	0.942	0.897	0.863	0.837	0.813	0.792	0.773	0.756	0.74	0.725	0.712		
14.00	0.976	0.946	0.897	0.863	0.835	0.811	0.79	0.771	0.753	0.737	0.723	0.709		
14.25	0.978	0.947	0.898	0.862	0.834	0.81	0.789	0.77	0.752	0.736	0.721	0.707		
14.50	0.948	0.898	0.862	0.833	0.809	0.787	0.768	0.751	0.734	0.72	0.706	
14.75	0.948	0.898	0.862	0.832	0.808	0.786	0.767	0.749	0.733	0.719	0.704	
15.00	0.948	0.899	0.861	0.832	0.807	0.785	0.766	0.748	0.732	0.717	0.703	
15.25	0.947	0.899	0.861	0.831	0.806	0.784	0.764	0.746	0.73	0.716	0.702	
15.50	0.947	0.899	0.861	0.83	0.804	0.782	0.763	0.745	0.728	0.714	0.7	
15.75	0.946	0.899	0.86	0.829	0.803	0.781	0.761	0.743	0.727	0.712	0.698	
16.00	0.945	0.9	0.859	0.828	0.802	0.779	0.759	0.741	0.725	0.71	0.696	
16.25	0.945	0.9	0.859	0.827	0.801	0.778	0.757	0.739	0.723	0.708	0.694	
16.50	0.945	0.9	0.858	0.826	0.799	0.776	0.756	0.738				

TABLE PG-68.7M
SUPERHEAT CORRECTION FACTOR, K_{sh} (CONT'D)

Flowing Pressure (MPa)	Superheat Correction Factor, K_{sh} Total Temperature, °C, of Superheated Steam																	
	205	225	250	275	300	325	350	375	400	425	450	475	500	525	550	575	600	625
17.00	0.944	0.9	0.856	0.823	0.796	0.773	0.752	0.734	0.717	0.702	0.688
17.25	0.944	0.9	0.855	0.822	0.794	0.771	0.75	0.732	0.715	0.7	0.686
17.50	0.944	0.9	0.854	0.82	0.792	0.769	0.748	0.73	0.713	0.698	0.684
17.75	0.944	0.9	0.853	0.819	0.791	0.767	0.746	0.728	0.711	0.696	0.681
18.00	0.944	0.901	0.852	0.817	0.789	0.765	0.744	0.725	0.709	0.694	0.679
18.25	0.945	0.901	0.851	0.815	0.787	0.763	0.742	0.723	0.706	0.691	0.677
18.50	0.945	0.901	0.85	0.814	0.785	0.761	0.739	0.72	0.704	0.689	0.674
18.75	0.945	0.901	0.849	0.812	0.783	0.758	0.737	0.718	0.701	0.686	0.671
19.00	0.946	0.901	0.847	0.81	0.781	0.756	0.734	0.715	0.698	0.683	0.669
19.25	0.948	0.901	0.846	0.808	0.778	0.753	0.732	0.713	0.696	0.681	0.666
19.50	0.95	0.9	0.844	0.806	0.776	0.75	0.729	0.71	0.693	0.677	0.663
19.75	0.952	0.899	0.842	0.803	0.773	0.748	0.726	0.707	0.69	0.674	0.66
20.00	0.899	0.84	0.801	0.77	0.745	0.723	0.704	0.687	0.671	0.657
20.25	0.899	0.839	0.798	0.767	0.742	0.72	0.701	0.683	0.668	0.654
20.50	0.899	0.837	0.795	0.764	0.738	0.717	0.697	0.68	0.665	0.651
20.75	0.898	0.834	0.792	0.761	0.735	0.713	0.694	0.677	0.661	0.647
21.00	0.896	0.832	0.79	0.758	0.732	0.71	0.691	0.673	0.658	0.643
21.25	0.894	0.829	0.786	0.754	0.728	0.706	0.686	0.669	0.654	0.64
21.50	0.892	0.826	0.783	0.75	0.724	0.702	0.682	0.665	0.65	0.636
21.75	0.891	0.823	0.779	0.746	0.72	0.698	0.679	0.661	0.646	0.631
22.00	0.887	0.82	0.776	0.743	0.716	0.694	0.674	0.657	0.641	0.627

PG-69 CERTIFICATION OF CAPACITY OF PRESSURE RELIEF VALVES

PG-69.1 Before the Code symbol is applied to any pressure relief valve or power-actuated pressure relieving valve, the valve manufacturer shall have the relieving capacity of his pressure relief valves certified in accordance with the provisions of this paragraph.

PG-69.1.1 Capacity certification tests shall be conducted using dry saturated steam. The limits for test purposes shall be 98% minimum quality and 20°F (10°C) maximum superheat. Correction from within these limits may be made to the dry saturated condition.

PG-69.1.2 Tests shall be conducted at a place that meets the requirements of A-312.

PG-69.1.3 Capacity test data reports for each pressure relief valve design and size, signed by the manufacturer and Authorized Observer witnessing the tests, together with drawings showing the valve construction, shall be submitted to the ASME designee for review and acceptance.¹⁰

¹⁰ Valve capacities are published in "Pressure Relief Device Certifications." This publication may be obtained from the National Board of Boiler and Pressure Vessel Inspectors, 1055 Crupper Ave., Columbus, OH 43299.

PG-69.1.4 Capacity certification tests shall be conducted at a pressure that does not exceed the set pressure by 3% or 2 psi (15 kPa), whichever is greater. Pressure relief valves shall be adjusted so that the blowdown does not exceed 4% of the set pressure. For pressure relief valves set at or below 100 psi (700 kPa), the blowdown shall be adjusted so as not to exceed 4 psi (30 kPa). Pressure relief valves used on forced-flow steam generators with no fixed steam and waterline, and pressure relief

valves used on high-temperature water boilers shall be adjusted so that the blow down does not exceed 10% of the set pressure. The relieving pressure shall be noted and recorded.

PG-69.1.5 Capacity certification of pilot operated pressure relief valves may be based on tests without the pilot valves installed, provided prior to capacity tests it has been demonstrated by test to the satisfaction of the Authorized Observer that the pilot valve will cause the main valve to open fully at a pressure which does not exceed the set pressure by more than 3% or 2 psi (15 kPa), whichever is greater, and that the pilot valve in combination with the main valve will meet all of the requirements of this Section.

PG-69.1.6 Pressure relief valves for economizer service shall also be capacity certified using water at a temperature between 40°F and 125°F (4°C and 50°C). The pressure relief valves shall be tested without change to the adjustments established in PG-69.1.1 to PG-69.1.4.

PG-69.2 Relieving capacities shall be determined using one of the following methods.

PG-69.2.1 Three Valve Method. A capacity certification test is required on a set of three pressure relief valves for each combination of size, design, and pressure setting. The capacity of each valve of the set shall fall within a range of ±5% of the average capacity. If one of the three pressure relief valves tested falls outside this range, it shall be replaced by two valves, and a new average shall be calculated based on all four valves, excluding the replaced valve. Failure of any of the four capacities to fall within a range of ±5% of the new average shall be cause to refuse certification of that particular valve design.

The rated relieving capacity for each combination of design, size, and test pressure shall be 90% of the average capacity.

TABLE PG-69.2.3
 SUPERCRITICAL CORRECTION FACTOR, K_{sc}

Flowing Pressure, psia	Total Temperature, °F, of Supercritical Steam									
	750	800	850	900	950	1,000	1,050	1,100	1,150	1,200
3,208.2	1.059	0.971	0.913	0.872	0.839	0.811	0.788	0.767	0.748	0.731
3,250	1.064	0.975	0.916	0.874	0.841	0.813	0.788	0.767	0.748	0.731
3,300	1.070	0.980	0.919	0.876	0.842	0.814	0.790	0.768	0.749	0.732
3,350	1.077	0.985	0.922	0.878	0.844	0.815	0.791	0.769	0.750	0.732
3,400	1.084	0.990	0.925	0.881	0.846	0.817	0.792	0.770	0.750	0.733
3,450	1.091	0.996	0.929	0.883	0.848	0.818	0.793	0.771	0.751	0.734
3,500	1.100	1.002	0.932	0.885	0.849	0.819	0.794	0.772	0.752	0.734
3,550	1.109	1.008	0.935	0.888	0.851	0.821	0.795	0.773	0.753	0.735
3,600	1.118	1.014	0.939	0.890	0.853	0.822	0.796	0.774	0.754	0.735
3,650	1.129	1.020	0.943	0.893	0.855	0.824	0.797	0.775	0.754	0.736
3,700	1.141	1.027	0.946	0.895	0.857	0.825	0.799	0.775	0.755	0.737
3,750	1.153	1.034	0.950	0.898	0.859	0.827	0.800	0.776	0.756	0.737
3,800	1.168	1.041	0.954	0.900	0.861	0.828	0.801	0.777	0.757	0.738
3,850	1.186	1.048	0.958	0.903	0.862	0.830	0.802	0.778	0.757	0.739
3,900	1.205	1.056	0.962	0.906	0.864	0.831	0.803	0.779	0.758	0.739
3,950	1.227	1.064	0.966	0.908	0.866	0.833	0.804	0.780	0.759	0.740
4,000	1.251	1.072	0.970	0.911	0.868	0.834	0.806	0.781	0.760	0.741
4,050	1.279	1.080	0.974	0.914	0.870	0.836	0.807	0.782	0.760	0.741
4,100	1.310	1.089	0.978	0.916	0.872	0.837	0.808	0.783	0.761	0.742
4,150	1.343	1.098	0.983	0.919	0.874	0.839	0.809	0.784	0.762	0.743
4,200	1.395	1.107	0.987	0.922	0.876	0.840	0.810	0.785	0.763	0.743
4,250	1.444	1.116	0.992	0.925	0.878	0.842	0.812	0.786	0.764	0.744
4,300	1.491	1.125	0.997	0.928	0.881	0.844	0.813	0.787	0.765	0.745
4,350	1.538	1.135	1.002	0.931	0.883	0.845	0.814	0.788	0.765	0.745
4,400	...	1.146	1.007	0.934	0.885	0.847	0.815	0.789	0.766	0.746
4,450	...	1.157	1.012	0.937	0.887	0.848	0.817	0.790	0.767	0.746
4,500	...	1.169	1.017	0.940	0.889	0.850	0.818	0.791	0.768	0.747
4,550	...	1.181	1.022	0.943	0.892	0.852	0.819	0.792	0.768	0.748
4,600	...	1.194	1.027	0.947	0.894	0.853	0.820	0.793	0.769	0.749
4,650	...	1.207	1.033	0.950	0.896	0.855	0.822	0.794	0.770	0.749
4,700	...	1.220	1.038	0.953	0.898	0.857	0.823	0.795	0.771	0.750
4,750	...	1.234	1.044	0.957	0.900	0.858	0.824	0.796	0.772	0.751
4,800	...	1.248	1.050	0.960	0.903	0.860	0.826	0.797	0.773	0.751
4,850	...	1.263	1.056	0.963	0.905	0.862	0.827	0.798	0.774	0.752
4,900	...	1.278	1.062	0.967	0.908	0.863	0.828	0.799	0.774	0.753
4,950	...	1.294	1.069	0.970	0.910	0.865	0.830	0.800	0.775	0.753
5,000	...	1.310	1.075	0.974	0.912	0.867	0.831	0.801	0.776	0.754
5,050	...	1.326	1.082	0.978	0.915	0.869	0.832	0.803	0.777	0.755
5,100	...	1.343	1.088	0.981	0.917	0.871	0.834	0.804	0.778	0.755
5,150	...	1.360	1.095	0.985	0.920	0.872	0.835	0.805	0.779	0.756
5,200	...	1.377	1.102	0.989	0.922	0.874	0.837	0.806	0.780	0.757
5,250	...	1.393	1.109	0.993	0.925	0.876	0.838	0.807	0.780	0.758
5,300	...	1.411	1.116	0.997	0.927	0.878	0.839	0.808	0.781	0.758
5,350	...	1.427	1.123	1.001	0.930	0.880	0.841	0.809	0.782	0.759
5,400	...	1.443	1.131	1.004	0.933	0.882	0.842	0.810	0.783	0.760
5,450	...	1.460	1.139	1.009	0.935	0.884	0.844	0.811	0.784	0.760
5,500	...	1.476	1.146	1.013	0.938	0.886	0.845	0.812	0.785	0.761
5,550	...	1.491	1.154	1.017	0.941	0.887	0.846	0.813	0.786	0.762
5,600	...	1.507	1.162	1.021	0.943	0.889	0.848	0.815	0.787	0.763

TABLE PG-69.2.3
SUPERCRITICAL CORRECTION FACTOR, K_{sc} (CONT'D)

Flowing Pressure, psia	Total Temperature, °F, of Supercritical Steam									
	750	800	850	900	950	1,000	1,050	1,100	1,150	1,200
5,650	...	1.522	1.171	1.025	0.946	0.891	0.849	0.816	0.788	0.763
5,700	...	1.536	1.179	1.030	0.949	0.893	0.851	0.817	0.788	0.764
5,750	...	1.551	1.187	1.034	0.952	0.895	0.852	0.818	0.789	0.765
5,800	...	1.565	1.195	1.038	0.955	0.897	0.854	0.819	0.790	0.765
5,850	...	1.578	1.204	1.043	0.957	0.899	0.855	0.820	0.791	0.766
5,900	...	1.591	1.212	1.047	0.960	0.901	0.857	0.821	0.792	0.767
5,950	...	1.603	1.221	1.052	0.963	0.903	0.858	0.823	0.793	0.768
6,000	...	1.615	1.229	1.057	0.966	0.906	0.860	0.824	0.794	0.768

PG-69.2.2 Slope Method. If a Manufacturer wishes to apply the Code Symbol to a design of pressure relief valves, four valves of each combination of pipe size and orifice size shall be tested. These four valves shall be set at pressures that cover the approximate range of pressures for which the valve will be used or covering the range available at the certified test facility that shall conduct the tests. The capacities based on these four tests shall be as follows:

(a) The slope WIP of the actual measured capacity versus the flow pressure for each test point shall be calculated and averaged

For steam

$$\text{slope} = \frac{W}{P} = \frac{\text{measured capacity}}{\text{absolute flow rating pressure}}$$

For water

$$\text{slope} = \frac{W}{P} = \frac{\text{measured capacity}}{\sqrt{(\text{flow rating pressure}) - (\text{discharge pressure})}}$$

All values derived from the testing must fall within $\pm 5\%$ of the average value:

minimum slope = 0.95 x average slope

maximum slope = 1.05 x average slope

If the values derived from the testing do not fall between the minimum and maximum slope values, the Authorized Observer shall require that additional valves be tested at the rate of two for each valve beyond the maximum and minimum values with a limit of four additional valves.

For steam applications the relieving capacity to be stamped on the valve shall not exceed 90% of the average slope times the absolute accumulation pressure

rated slope = 0.90 x average slope

For water applications the relieving capacity shall not exceed 90% of the average slope multiplied by the square root of the difference between the flow rating pressure and the valve discharge pressure.

rated slope = 0.9 x average slope

$$\times \sqrt{\text{flow rating pressure} - \text{discharge pressure}}$$

(U.S. Customary Units)

stamped capacity \leq rated slope (1.03 x set pressure + 14.7)

or (set pressure + 2 psi + 14.7), whichever is greater

(SI Units)

stamped capacity \leq rated slope (1.03 x set pressure + 0.101)

or (set pressure + 0.015 MPa + 0.101), whichever is greater

TABLE PG-69.2.3M
 SUPERCRITICAL CORRECTION FACTOR, K_{SC}

Flowing Pressure, MPa	Total Temperature, °C, of Supercritical Steam										
	400	425	450	475	500	525	550	575	600	625	650
22.12	1.056	0.976	0.922	0.883	0.851	0.824	0.801	0.781	0.762	0.745	0.730
22.25	1.058	0.978	0.924	0.884	0.852	0.825	0.802	0.781	0.763	0.746	0.730
22.50	1.063	0.982	0.926	0.886	0.853	0.826	0.803	0.782	0.763	0.746	0.731
22.75	1.067	0.985	0.929	0.887	0.855	0.827	0.803	0.783	0.764	0.747	0.731
23.00	1.072	0.989	0.931	0.889	0.856	0.828	0.804	0.783	0.764	0.747	0.732
23.25	1.077	0.993	0.934	0.891	0.858	0.830	0.805	0.784	0.765	0.748	0.732
23.50	1.082	0.997	0.937	0.893	0.859	0.831	0.806	0.785	0.766	0.748	0.732
23.75	1.087	1.001	0.939	0.895	0.860	0.832	0.807	0.785	0.766	0.749	0.733
24.00	1.093	1.006	0.942	0.897	0.862	0.833	0.808	0.786	0.767	0.749	0.733
24.25	1.099	1.010	0.945	0.899	0.863	0.834	0.809	0.787	0.768	0.750	0.734
24.50	1.106	1.014	0.948	0.901	0.865	0.835	0.810	0.788	0.768	0.751	0.734
24.75	1.112	1.019	0.950	0.903	0.866	0.836	0.811	0.789	0.769	0.751	0.735
25.00	1.120	1.024	0.953	0.905	0.868	0.837	0.812	0.789	0.769	0.752	0.735
25.25	1.128	1.029	0.956	0.907	0.869	0.839	0.813	0.790	0.770	0.752	0.736
25.50	1.136	1.034	0.959	0.909	0.871	0.840	0.814	0.791	0.771	0.753	0.736
25.75	1.145	1.039	0.962	0.911	0.872	0.841	0.815	0.792	0.771	0.753	0.737
26.00	1.155	1.045	0.966	0.913	0.874	0.842	0.816	0.792	0.772	0.754	0.737
26.25	1.166	1.050	0.969	0.915	0.875	0.843	0.817	0.793	0.773	0.754	0.737
26.50	1.178	1.056	0.972	0.917	0.877	0.845	0.818	0.794	0.773	0.755	0.738
26.75	1.192	1.062	0.975	0.919	0.879	0.846	0.819	0.795	0.774	0.755	0.738
27.00	1.206	1.068	0.979	0.921	0.880	0.847	0.820	0.796	0.775	0.756	0.739
27.25	1.222	1.074	0.982	0.924	0.882	0.848	0.820	0.796	0.775	0.756	0.739
27.50	1.239	1.081	0.985	0.926	0.883	0.850	0.821	0.797	0.776	0.757	0.740
27.75	1.258	1.088	0.989	0.928	0.885	0.851	0.822	0.798	0.777	0.758	0.740
28.00	1.278	1.095	0.992	0.930	0.887	0.852	0.824	0.799	0.777	0.758	0.741
28.25	1.300	1.102	0.996	0.933	0.888	0.854	0.825	0.800	0.778	0.759	0.741
28.50	1.323	1.109	1.000	0.935	0.890	0.855	0.826	0.801	0.779	0.759	0.742
28.75	1.354	1.117	1.004	0.937	0.892	0.856	0.827	0.801	0.779	0.760	0.742
29.00	1.390	1.126	1.007	0.940	0.893	0.857	0.828	0.802	0.780	0.760	0.743
29.25	1.424	1.134	1.011	0.942	0.895	0.859	0.829	0.803	0.781	0.761	0.743
29.50	1.457	1.143	1.015	0.945	0.897	0.860	0.830	0.804	0.781	0.762	0.744
29.75	1.490	1.151	1.019	0.947	0.899	0.861	0.831	0.805	0.782	0.762	0.744
30.00	...	1.158	1.023	0.950	0.900	0.863	0.832	0.806	0.783	0.763	0.745
30.25	...	1.098	1.028	0.952	0.902	0.864	0.833	0.806	0.784	0.763	0.745
30.50	...	1.083	1.032	0.955	0.904	0.865	0.834	0.807	0.784	0.764	0.746
30.75	...	1.090	1.036	0.957	0.906	0.867	0.835	0.808	0.785	0.764	0.746
31.00	...	1.099	1.041	0.960	0.908	0.868	0.836	0.809	0.786	0.765	0.746
31.25	...	1.107	1.046	0.963	0.910	0.870	0.837	0.810	0.786	0.766	0.747
31.50	...	1.115	1.050	0.966	0.911	0.871	0.838	0.811	0.787	0.766	0.748
31.75	...	1.124	1.055	0.968	0.913	0.872	0.839	0.812	0.788	0.767	0.748
32.00	...	1.133	1.060	0.971	0.915	0.874	0.840	0.812	0.788	0.767	0.748
32.25	...	1.142	1.065	0.974	0.917	0.875	0.841	0.813	0.789	0.768	0.749
32.50	...	1.151	1.070	0.977	0.919	0.877	0.843	0.814	0.790	0.769	0.750
32.75	...	1.160	1.075	0.980	0.921	0.878	0.844	0.815	0.791	0.769	0.750
33.00	...	1.170	1.080	0.983	0.923	0.879	0.845	0.816	0.791	0.770	0.750
33.25	...	1.180	1.085	0.986	0.925	0.881	0.846	0.817	0.792	0.770	0.751
33.50	...	1.190	1.091	0.988	0.927	0.882	0.847	0.818	0.793	0.771	0.751
33.75	...	1.201	1.096	0.992	0.929	0.884	0.848	0.819	0.793	0.772	0.752
34.00	...	1.211	1.102	0.995	0.931	0.885	0.849	0.820	0.794	0.772	0.752

TABLE PG-69.2.3M
 SUPERCRITICAL CORRECTION FACTOR, K_{SC} (CONT'D)

Flowing Pressure, MPa	Total Temperature, °C, of Supercritical Steam										
	400	425	450	475	500	525	550	575	600	625	650
34.25	...	1.222	1.108	0.998	0.933	0.887	0.850	0.820	0.795	0.773	0.753
34.50	...	1.233	1.114	1.001	0.935	0.888	0.852	0.821	0.796	0.773	0.753
34.75	...	1.244	1.119	1.004	0.937	0.890	0.853	0.822	0.796	0.774	0.754
35.00	...	1.255	1.125	1.007	0.939	0.891	0.854	0.823	0.797	0.775	0.754
35.25	...	1.267	1.131	1.011	0.941	0.893	0.855	0.824	0.798	0.775	0.755
35.50	...	1.278	1.137	1.014	0.944	0.894	0.856	0.825	0.799	0.776	0.755
35.75	...	1.290	1.144	1.017	0.946	0.896	0.858	0.826	0.799	0.776	0.756
36.00	...	1.301	1.150	1.021	0.948	0.898	0.859	0.827	0.800	0.777	0.757
36.25	...	1.313	1.156	1.024	0.950	0.899	0.860	0.828	0.801	0.778	0.757
36.50	...	1.324	1.162	1.027	0.952	0.901	0.861	0.829	0.802	0.778	0.758
36.75	...	1.336	1.169	1.031	0.955	0.902	0.862	0.830	0.802	0.779	0.758
37.00	...	1.347	1.175	1.034	0.957	0.904	0.864	0.831	0.803	0.779	0.759
37.25	...	1.358	1.182	1.038	0.959	0.906	0.865	0.832	0.804	0.780	0.759
37.50	...	1.369	1.188	1.042	0.961	0.907	0.866	0.833	0.805	0.781	0.760
37.75	...	1.380	1.195	1.045	0.964	0.909	0.867	0.834	0.805	0.781	0.760
38.00	...	1.391	1.201	1.049	0.966	0.910	0.868	0.834	0.806	0.782	0.761
38.25	...	1.402	1.208	1.053	0.968	0.912	0.870	0.835	0.807	0.783	0.761
38.50	...	1.412	1.215	1.056	0.971	0.914	0.871	0.836	0.808	0.783	0.762
38.75	...	1.422	1.222	1.060	0.973	0.915	0.872	0.837	0.809	0.784	0.762
39.00	...	1.433	1.228	1.064	0.975	0.917	0.873	0.838	0.809	0.784	0.763
39.25	...	1.443	1.235	1.068	0.978	0.919	0.875	0.839	0.810	0.785	0.763
39.50	...	1.453	1.242	1.072	0.980	0.921	0.876	0.840	0.811	0.786	0.764
39.75	...	1.463	1.248	1.076	0.983	0.922	0.877	0.841	0.812	0.786	0.764
40.00	...	1.472	1.255	1.080	0.985	0.924	0.879	0.842	0.812	0.787	0.765
40.25	...	1.481	1.262	1.084	0.988	0.926	0.880	0.843	0.813	0.788	0.765
40.50	...	1.490	1.268	1.088	0.990	0.928	0.881	0.844	0.814	0.788	0.766
40.75	...	1.499	1.275	1.092	0.993	0.929	0.882	0.845	0.815	0.789	0.766
41.00	...	1.507	1.282	1.096	0.995	0.931	0.884	0.846	0.816	0.790	0.767
41.25	...	1.515	1.288	1.100	0.998	0.933	0.885	0.847	0.816	0.790	0.767

PG-69.2.3 Coefficient of Discharge Method. A coefficient of discharge for the design, K , may be established for a specific valve design according to the following procedure:

(a) For each design, the pressure relief valve manufacturer shall submit for test at least three valves for each of three different sizes (a total of nine valves). Each valve of a given size shall be set at a different pressure, covering the range of pressures for which the valve will be used or the range available at the facility where the tests are conducted.

For each valve design where the coefficient of discharge has been determined that is intended to be restricted in lift, the Manufacturer shall have capacity tests conducted on three valves of different sizes. Each size valve shall be tested for capacity at the minimum lift for which certification is required, and at two intermediate lift points between the full rated lift and minimum lift certification points. Each of the three test valves shall be set at a different pressure.

For each valve tested, it shall be verified that actual measured capacity at restricted lift will equal or exceed the rated capacity at full rated lift multiplied by the ratio of measured restricted lift to full rated lift.

(b) Tests shall be made on each pressure relief valve to determine its lift at capacity, popping, and blowdown pressures, and

actual relieving capacity. An individual coefficient, K_D , shall be established for each valve as follows:

$$K_D = \frac{\text{actual flow}}{\text{theoretical flow}} = \text{individual coefficient of discharge}$$

Where actual flow is determined by test and theoretical flow, W_T is calculated by one of the following equations:

For tests with dry saturated steam

For 45 deg seat

(U.S. Customary Units)

$$W_T = 51.5 \times \pi DLP \times 0.707$$

(SI Units)

$$W_T = 5.25 \times \pi DLP \times 0.707$$

For flat seat

(U.S. Customary Units)

$$W_T = 51.5 \times \pi DLP$$

(SI Units)

$$W_T = 5.25 \times \pi DLP$$

For nozzle

(U.S. Customary Units)

$$W_T = 51.5 AP$$

(SI Units)

$$W_T = 5.25 AP$$

For tests with water

For 45 deg seat

(U.S. Customary Units)

$$W = 1\,135.8 \frac{0.95}{5.25} \times \frac{dW}{dP} \sqrt{\frac{P}{v}}$$

(SI Units)

$$W_T = 5\,092 \pi DL (0.707) \sqrt{(P - P_d)w}$$

For flat seat

(U.S. Customary Units)

$$W_T = 2,407 \pi DL \sqrt{(P - P_d)w}$$

(SI Units)

$$W_T = 5\,092 \pi DL \sqrt{(P - P_d)w}$$

For nozzle

(U.S. Customary Units)

$$W_T = 2,407 A \sqrt{(P - P_d)w}$$

(SI Units)

$$W_T = 5\,092 A \sqrt{(P - P_d)w}$$

where

A = nozzle throat area, in.² (mm²)

D = seat diameter, in. (mm)

L = lift at pressure P, in. (mm)

P = (1.03 X set pressure + 14.7), psia, or

= (set pressure + 2 + 14.7), psia, whichever is greater

= (1.03 X set pressure + 0.101), MPa, or

= (set pressure + 0.014 + 0.101), MPa, whichever is greater

P_d = pressure at discharge of the valve, psia (MPa)W_T = theoretical flow, lb/hr (kg/hr)w = specific weight of water at inlet conditions, lb/ft³ (kg/m³)

To convert lb/hr of water to gal/min of water, multiply the capacity in lb/hr by 1/500. To convert kg/hr of water to liter/min of water, multiply the capacity in kg/hr by 1/60.

The average of the coefficients K_D of the nine tests required shall be multiplied by 0.90, and this product shall be taken as the coefficient K of that design. All individual coefficients of discharge, K_D , shall fall within a range of $\pm 5\%$ of the average coefficient found. If a valve fails to meet this requirement, the Authorized Observer shall require two additional valves to be tested as replacements for each valve having an individual coefficient, K_D , outside the $\pm 5\%$ range, with a limit of four additional valves. Failure of a coefficient, K_D , to fall within $\pm 5\%$ of the new average value, excluding the replaced valve(s), shall be cause to refuse certification of that particular valve design.

The rated relieving capacity of all sizes and set pressures of a given design, for which K has been established under the provision of this paragraph, shall be determined by the equation:

$$W \leq W_T \times K$$

where

K = coefficient of discharge for the design

W = rated relieving capacity, lb/hr (kg/hr)

W_T = theoretical flow, defined by the same equation used to determine K_D , lb/hr (kg/hr)

The coefficient of discharge for the design shall be not greater than 0.878 (the product of 0.9 x 0.975). The coefficient shall not be applied to valves whose beta ratio (ratio of valve throat to inlet diameter) lies outside the range of 0.15 to 0.75, unless tests have demonstrated that the individual coefficient of discharge, K_D , for valves at the extreme ends of a larger range, is within $\pm 5\%$ of the average coefficient, K_D .

For designs where the lift is used to determine the flow area, all valves shall have the same nominal lift to seat diameter ratio (L/D).

For pressures over 1,500 psig (10.3 MPa) and up to 3,200 psig (22.1 MPa), the value of W shall be multiplied by the correction factor:

(U.S. Customary Units)

$$\frac{0.1906P - 1.000}{0.2292P - 1.061}$$

$$0.2292P - 1.061$$

(SI Units)

$$\frac{27.6P - 1.000}{33.2P - 1.061}$$

$$33.2P - 1.061$$

For pressures over 3,200 psig (22.1 MPa), the value of W shall be multiplied by the appropriate supercritical correction factor, K_{sc} , from Table PG-69.2.3.

PG-69.3 If a manufacturer wishes to apply the Code symbol to a power-actuated pressure relieving valve under PG-67.4.1, one valve of each combination of inlet pipe size and orifice size to be used with that inlet pipe size shall be tested. The valve shall be capacity tested at four different pressures approximately covering the range of the certified test facility on which the tests are conducted. The capacities, as determined by these four tests, shall be plotted against the absolute flow test pressure and a line drawn through these four test points. All points must lie within $\pm 5\%$ in capacity value of the plotted line and must pass through 0-0. From the plotted line, the slope of the line dW/dP shall be determined and a factor of (0.90/51.45) x (dW/dP) shall be applied to capacity computations in the supercritical region at elevated pressures by means of the isentropic flow equation.

(U.S. Customary Units)

$$W = 1,135.8 \frac{0.90}{51.45} \times \frac{dW}{dP} \sqrt{\frac{P}{v}}$$

(SI Units)

$$W = 1\,135.8 \frac{0.95}{5.25} \times \frac{dW}{dP} \sqrt{\frac{P}{v}}$$

where

dW/dP = rate of change of measured capacity with respect to absolute pressure

P = absolute inlet pressure, psia (MPa)

v = inlet specific volume, ft³/lb (m³/kg)

W = capacity, lb of steam/hr (kg/hr)

NOTES: The constant 1,135.8 is based on a γ factor of 1.30, which is accurate for superheated steam at temperature above approximately 800°F (430°C). In interest of accuracy, other methods of capacity computations must be used at temperatures below 800°F (430°C) at supercritical pressures.

PG-69.4 Power-actuated pressure relieving valves, having capacities certified in accordance with the provision of PG-69.3 and computed in accordance with the formula contained therein, shall be marked as required by PG-110 with the com-

Published under s. 35.93, Stats. Updated on the first day of each month. Entire code is always current. The Register date on each page is the date the chapter was last published.

puted capacity, corresponding to 3% above the full load operating pressure and temperature conditions at the valve inlet when the valve is operated by the controller, and they shall also be stamped with the set pressure of the controller. When the valve is marked as required by this paragraph, it shall be the guarantee by the manufacturer that the valve also conforms to the details of construction herein specified.

PG-69.6 When changes are made in the design of a safety or safety relief valve in such a manner as to affect the flow path, lift, or performance characteristics of the valve, new tests in accordance with this Section shall be performed.

PG-70 CAPACITY OF PRESSURE RELIEF VALVES

PG-70.1 Subject to the minimum number required by PG-67.1, the number of pressure relief valves required shall be determined on the basis of the maximum designed steaming capacity, as determined by the boiler Manufacturer, and the relieving capacity marked on the valves by the manufacturer.

PG-71 MOUNTING OF PRESSURE RELIEF VALVES

PG-71.1 When two or more pressure relief valves are used on a boiler, they may be mounted either separately or as twin valves made by placing individual valves on Y-bases, or duplex valves having two valves in the same body casing. Twin valves made by placing individual valves on Y-bases, or duplex valves having two valves in the same body, shall be of approximately equal capacity.

When not more than two valves of different sizes are mounted singly the relieving capacity of the smaller valve shall be not less than 50% of that of the larger valve.

PG-71.2 The pressure relief valve or valves shall be connected to the boiler independent of any other connection, and attached as close as possible to the boiler or the normal steam flow path, without any unnecessary intervening pipe or fitting. Such intervening pipe or fitting shall be not longer than the face-to-face dimension of the corresponding tee fitting of the same diameter and pressure under the applicable ASME Standard listed in PG-42 and shall also comply with PG-8 and PG-39. Every pressure relief valve shall be connected so as to stand in an upright position, with spindle vertical. On high-temperature water boilers of the watertube forced-circulation type, the valve shall be located at the boiler outlet.

PG-71.3 The opening or connection between the boiler and the pressure relief valve shall have at least the area of the valve inlet. No valve of any description shall be placed between the required pressure relief valve or valves and the boiler, nor on the discharge pipe between the pressure relief valve and the atmosphere. When a discharge pipe is used, the cross-sectional area shall be not less than the full area of the valve outlet or of the total of the areas of the valve outlets, discharging thereinto. It shall be as short and straight as possible and so arranged as to avoid undue stresses on the valve or valves.

All pressure relief valve discharges shall be so located or piped as to be carried clear from running boards or platforms. Ample provision for gravity drain shall be made in the discharge pipe at or near each pressure relief valve, and where water of condensation may collect. Each valve shall have an open gravity drain through the casing below the level of the valve seat. For iron- and steel-bodied valves exceeding NPS 2 1/2 (DN 65), the drain hole shall be tapped not less than NPS 3/8 (DN 10).

Discharge piping from pressure relief valves on high temperature water boilers shall be provided with adequate provisions for water drainage as well as the steam venting.

The installation of cast iron bodied pressure relief valves for high-temperature water boilers is prohibited.

PG-71.4 If a muffler is used on a pressure relief valve, it shall have sufficient outlet area to prevent back pressure from interfering with the proper operation and discharge capacity of the valve. The muffler plates or other devices shall be so constructed as to avoid a possibility of restriction of the steam passages due to deposit. Mufflers shall not be used on high-temperature water boiler pressure relief valves.

When a pressure relief valve is exposed to outdoor elements that may affect operation of the valve, it is permissible to shield the valve with a satisfactory cover. The shield or cover shall be properly vented and arranged to permit servicing and normal operation of the valve.

PG-71.5 When a boiler is fitted with two or more pressure relief valves on one connection, this connection to the boiler shall have a cross-sectional area not less than the combined areas of inlet connections of all the pressure relief valves with which it connects and shall also meet the requirements of PG-71.3.

PG-71.6 Pressure relief valves may be attached to drums or headers by welding provided the welding is done in accordance with Code requirements.

PG-71.7 Every boiler shall have proper outlet connections for the required pressure relief valve, or valves, independent of any other outside steam connection, the area of opening to be at least equal to the aggregate areas of inlet connections of all of the pressure relief valves to be attached thereto. An internal collecting pipe, splash plate, or pan may be used, provided the total area for inlet of steam thereto is not less than twice the aggregate areas of the inlet connections of the attached pressure relief valves. The holes in such collecting pipes shall be at least 1/4 in. (6 mm) in diameter and the least dimension in any other form of opening for inlet of steam shall be 1/4 in. (6 mm).

Such dimensional limitations to operation for steam need not apply to steam scrubbers or driers provided the net free steam inlet area of the scrubber or drier is at least 10 times the total area of the boiler outlets for the pressure relief valves.

PG-71.8 If pressure relief valves are attached to a separate steam drum or dome, the opening between the boiler proper and the steam drum or dome shall be not less than required by PG-71.7.

PG-72 OPERATION OF PRESSURE RELIEF VALVES

PG-72.1 Pressure relief valves shall be designed and constructed to operate without chattering, with a minimum blow-down of 2 psi (15 kPa) or 2% of the set pressure, whichever is greater, and to attain full lift at a pressure not greater than 3% above their set pressure.

Pressure relief valves used on forced-flow steam generators with no fixed steam and waterline, and pressure relief valves used on high-temperature water boilers must be marked for these special services by the valve Manufacturer or Assembler.

PG-72.2 The set pressure tolerance plus or minus shall not exceed that specified in the following table:

Set Pressure, psi (MPa)	Tolerance, Plus or Minus From Set Pressure
≤ 70 (0.5)	2 psi (15 kPa)
> 70 (0.5) and ≤ 300 (2.1)	3% of set pressure
> 300 (2.1) and ≤ 1,000 (7.0)	10 psi (70 kPa)
> 1,000 (7.0)	1% of set pressure

PG-72.3 The spring in a pressure relief valve shall not be reset for any pressure more than 5% above or below that for which the valve is marked unless the new setting is within the spring design range established by the manufacturer or is determined to be acceptable to the manufacturer.

If the set pressure is to be adjusted within the limits specified above, the adjustment shall be performed by the manufacturer, his authorized representative, or an assembler. An additional valve data tag identifying the new set pressure, capacity, and date shall be furnished and installed, and the valve shall be resealed.

PG-72.4 If the set pressure of a valve is changed so as to require a new spring, the spring shall be acceptable to the manufacturer. The spring installation and valve adjustment shall be performed by the manufacturer, his authorized representative, or an assembler. A new nameplate as described in PG-110 shall be furnished and installed, and the valve shall be resealed.

PG-73 MINIMUM REQUIREMENTS FOR PRESSURE RELIEF VALVES

PG-73.1 Permissible Pressure Relief Valves

PG-73.1.1 Pressure relief valves shall be either direct spring-loaded safety valves, direct spring-loaded safety relief valves, or pilot-operated pressure relief valves.

PG-73.1.2 Power-actuated pressure relieving valves shall only be used for applications specified in PG-67.4.1.

PG-73.1.3 Deadweight or weighted lever safety valves or safety relief valves shall not be used.

PG-73.1.4 Unless otherwise defined, the definitions relating to pressure relief devices in ASME PTC 25 shall apply.

PG-73.2 Minimum Requirements

PG-73.2.1 All pressure relief valves shall be so constructed that the failure of any part cannot obstruct the free and full discharge of steam and water from the valve. Pressure relief valves shall have the seat inclined at any angle between 45 deg and 90 deg, inclusive, to the centerline of the disk.

PG-73.2.2 The design shall incorporate guiding arrangements necessary to insure consistent operation and tightness.

PG-73.2.3 The spring shall be designed so that the full lift spring compression shall be no greater than 80% of the nominal solid deflection. The permanent set of the spring (defined as the difference between the free height and height measured 10 min after the spring has been compressed solid three additional times after presetting at room temperature) shall not exceed 0.5% of the free height.

PG-73.2.4 To provide a means for verifying whether it is free, each safety valve or safety relief valve shall have a substantial lifting device, which when activated will release the seating force on the disk when the valve is subjected to pressure of at least 75% of the set pressure. The lifting device shall be such that it cannot lock or hold the valve disk in lifted position when the exterior lifting force is released. Disks of pressure relief valves used on high-temperature water boilers shall not be lifted while the temperature of the water exceeds 200°F (93°C). If it is desired to lift the valve disk to assure that it is free, this shall be done when the valve is subjected to a pressure of at least 75% of the set pressure. Pilot-operated pressure relief valves shall be provided with either a lifting device as described above or means for connecting and applying pressure to the pilot adequate to verify that the moving parts critical to proper operations are free to move. For high-temperature water boilers, the lifting mechanism shall be sealed against leakage.

PG-73.2.5 The seat of a pressure relief valve shall be fas-

tened to the body of the valve in such a way that there is no possibility of the seat lifting.

PG-73.2.6 A body drain below seat level shall be provided in the valve and this drain shall not be plugged during or after field installation. For valves exceeding NPS 2 ½ (DN 65), the drain hole or holes shall be tapped not less than NPS 3/8 (DN 10). For valves of NPS 2 ½ (DN 65) or smaller, the drain hole shall not be less than ¼ in. (6 mm) in diameter.

PG-73.2.7 In the design of the body of the valve, consideration shall be given to minimizing the effects of water deposits.

PG-73.2.8 Valves having screwed inlet or outlet connections shall be provided with wrenching surfaces to allow for normal installation without damaging operating parts.

PG-73.2.9 Means shall be provided in the design of all valves for use under this Section, for sealing all external adjustments. Seals shall be installed by the manufacturer, his authorized representative, or an assembler at the time of the initial adjustment. After spring replacement and/or subsequent adjustment, the valve shall be resealed. Seals shall be installed in such a manner as to prevent changing the adjustment without breaking the seal and, in addition, shall serve as a means of identifying the manufacturer, his authorized representative, or the assembler making the adjustment.

PG-73.2.10 Valve capacity may be restricted by restricting the lift of a valve provided the following requirements are met:

(a) The valve size shall be NPS ¾ (DN 20) or larger.

(b) No changes shall be made in the design of the valve except to change the valve lift by use of a lift restraining device described in (c) below.

(c) The restriction of valve capacity shall be permitted only by the use of a lift restraining device which shall limit valve lift and shall not otherwise interfere with flow through the valve. The design of the lift restraining device shall be subject to review by an ASME designee.

(d) The lift restraining device shall be designed so that, if adjustable, the adjustable feature can be sealed. Seals shall be installed by the valve Manufacturer or Assembler at the time of initial adjustment.

(e) Valves shall not have their lifts restricted to a value less than 30% of full rated lift, or 0.080 in. (2 mm).

(f) When sizing and selecting valves, the restricted lift nameplate capacity shall be determined by multiplying the capacity at full rated lift by the ratio of the restricted lift to the full rated lift.

PG-73.2.11 A pressure relief valve over NPS 3 (DN 80), used for pressure greater than 15 psig (100 kPa), shall have a flanged inlet connection or a welded inlet connection. The dimensions of the flanges subjected to boiler pressure shall conform to the applicable ASME standards as given in PG-42. The facing shall be similar to those illustrated in the standard.

PG-73.2.12 The pilot sensing line of pilot-operated pressure relief valves shall be adequately protected from freezing.

PG-73.3 Material Selections

PG-73.3.1 Cast iron seats and disks are not permitted.

PG-73.3.2 Adjacent sliding surfaces such as guides and disks or disk holders shall both be of corrosion-resistant material. Springs of corrosion-resistant material or having a corrosion-resistant coating are required. The seats and disks of pressure relief valves shall be of suitable material to resist corrosion by the lading fluid.

NOTES: The degree of corrosion resistance, appropriate to the intended

service, shall be a matter of agreement between the manufacturer and the purchaser.

PG-73.3.3 Materials used in bodies and bonnets or yokes shall be listed in Section II, Parts A and B, and identified in Tables 1A and 1B of Section II Part D, as permitted for Section I construction. Materials used in body to bonnet or body to yoke bolting shall be listed in ASME B16.34. Materials used in all other parts required for the pressure relieving or retaining function shall be

- (a) listed in ASME Section II
- (b) listed in ASTM Specifications (see Note below) or
- (c) controlled by the manufacturer of the pressure relief valve by a specification ensuring control of chemical and physical properties and quality at least equivalent to ASTM Standards (see Note below)

PG-73.3.4 Pressure relief valves may have bronze parts complying with either SB-61, SB-62 or SB-148, provided the maximum allowable stresses and temperatures do not exceed the values given in Table 1B of Section II, Part D, and shall be marked to indicate the class of material used. Such valves shall not be used on superheaters delivering steam at a temperature over 450°F (230°C) for SB-61 and SB-148, and 306°F (150°C) for SB-62, and shall not be used for high-temperature water boilers.

NOTES: It shall be the manufacturer's responsibility to ensure that the allowable stresses at temperature meet the requirements of Section II, Part D, Appendix 1, Mandatory Basis for Establishing Stress Values in Tables 1A and 1B.

PG-73.4 Inspection of Manufacturing and/or Assembly

PG-73.4.1 A manufacturer shall demonstrate to the satisfaction of an ASME designee that his manufacturing, production, and test facilities and quality control procedures will ensure close agreement between the performance of random production samples and the performance of those valves submitted for capacity certification.

PG-73.4.2 Manufacturing, assembly, inspection, and test operations including capacity, are subject to inspections at any time by an ASME designee.

PG-73.4.3 A Manufacturer or Assembler may be granted permission to apply the V Code Symbol to production pressure relief valves capacity-certified in accordance with PG-69, provided the following tests are successfully completed. This permission shall expire on the sixth anniversary of the date it is initially granted. This permission may be extended for 6-yr periods if the following tests are successfully repeated within the 6-mo period before expiration.

(a) Two sample production pressure relief valves of a size and capacity within the capability of an ASME accepted laboratory shall be selected by an ASME designee. The maximum blowdown for these samples shall not exceed the value specified in the following table:

Set Pressure, psi (kPa)	Maximum Blowdown
< 67 (500)	4 psi (30 kPa)
≥ 67 (500) and ≤ 250 (1 700)	6% of set pressure
>250 (1 700) and < 375 (2 500)	15 psi (100 kPa)
≥ 375 (2 500)	4% of set pressure

The blow down for sample valves designed for use on forced flow steam generators with no fixed steam and waterline or high-temperature water boilers shall not exceed 10% of the set pressure.

(b) Operational and capacity tests shall be conducted in the presence of an ASME designee at an ASME-accepted laboratory. The valve manufacturer or assembler shall be notified of

Published under s. 35.93, Stats. Updated on the first day of each month. Entire code is always current. The Register date on each page is the date the chapter was last published.

the time of the test and may have representatives present to witness the test.

(c) Should any valve fail to relieve at or above its certified capacity or should it fail to meet performance requirements in PG-72, the test shall be repeated at the rate of two replacement valves, selected in accordance with PG-73.4.3(a), for each valve that failed.

(d) Failure of any of the replacement valves to meet capacity or the performance requirements of this Section shall be cause for revocation within 60 days of the authorization to use the Code symbol on that particular type of valve. During this period, the Manufacturer or assembler shall demonstrate the cause of such deficiency and the action taken toward against future occurrence.

PG-73.4.4 Use of the Code Symbol Stamp by an assembler indicates the use of original unmodified parts in strict accordance with the instructions of the manufacturer of the valve.

(a) An assembler may transfer original and unmodified pressure relief parts produced by the Manufacturer to other Assemblers, provided the following conditions are met:

(1) both Assemblers have been granted permission to apply the V or UV Code Symbol to the specific valve type in which the parts are to be used

(2) the Quality Control System of the Assembler receiving the pressure relief valve parts shall define the controls for the procurement and acceptance of those parts

(3) the pressure relief valve parts are appropriately packaged, marked, or sealed by the Manufacturer to ensure that the parts are

- (a) produced, by the Manufacturer
- (b) the parts are original and unmodified

(b) However, an assembler may convert original finished parts by either machining to another finished part or applying a corrosion-resistant coating to valve springs for a specific application under the following conditions:

(1) Conversions shall be specified by the Manufacturer. Drawings and/or written instructions used for part conversion shall be obtained from the Manufacturer and shall include a drawing or description of the converted part before and after the conversion.

(2) The Assembler's quality control system, as accepted by a representative from an ASME-designated organization, must describe in detail the conversion of original parts, provisions for inspection and acceptance, personnel training, and control of current Manufacturer's drawings and/or written instructions.

(3) The Assembler must document each use of a converted part.

(4) The Assembler must demonstrate to the Manufacturer the ability to perform each type of conversion. The Manufacturer shall document all authorizations granted to perform part conversions. The Manufacturer and Assembler shall maintain a file of such authorizations.

(5) For an Assembler to offer restricted lift valves, the Assembler must demonstrate to the satisfaction of the Manufacturer the ability to perform valve lift restrictions. The Manufacturer shall document all authorizations granted to restrict the lift of the valves, and shall maintain records of the lift restrictions made by the Assembler. The Assembler shall maintain a file of such authorizations.

(6) At least annually a review shall be performed by the Manufacturer of an Assembler's system and conversion capabilities. The Manufacturer shall document the results of these

reviews. A copy of this documentation shall be kept on file by the Assembler. The review results shall be made available to a representative from an ASME designated organization.

NOTES: Within the requirements of PG-73.4 and PG-73.5, a *manufacturer* is defined as a person or organization who is completely responsible for design, material selection, capacity certification, manufacture of all component parts, assembly, testing, sealing, and shipping of pressure relief valves certified under this Section.

An *assembler* is defined as a person or organization who purchases or receives from a manufacturer the necessary component parts or valves and assembles, adjusts, tests, seals, and ships pressure relief valves certified under this Section at a geographical location other than and using facilities other than those used by the manufacturer.

PG-73.5 Testing by Manufacturers or Assemblers

PG-73.5.1 Pressure Testing. Each pressure relief valve to which the Code Symbol Stamp is to be applied shall be subjected to the following tests by the Manufacturer or Assembler:

(a) The pressure-containing parts of each valve shall be hydrostatically tested at a pressure at least 1.5 times the design pressure of the parts. Parts meeting the following criteria shall be exempt from pressure testing:

(1) the applied stress under hydrostatic test conditions does not exceed 50% of the allowable stress; and

(2) the part is not cast or welded.

(b) Alternatively, testing may be performed pneumatically at a pressure 1.25 times the design pressure of the part. Pneumatic testing can be hazardous; it is therefore recommended that special precautions be taken when conducting a pneumatic test.

(c) Testing may be done in the component or assembled condition.

(d) When the valve is designed for discharging directly to atmosphere, the valve components downstream of the valve disk are exempt from pressure testing.

(e) Valve components downstream of the disk and fully contained within the body are exempt from pressure testing.

(f) These tests shall be conducted after all machining and welding operations on the parts have been completed.

(g) There shall be no sign of leakage.

PG-73.5.2 Every valve shall be tested with steam by the manufacturer or assembler to demonstrate its set point and pressure-containing integrity. The blowdown control elements of the pressure relief valve shall be set to the Manufacturer's specifications.

PG-73.5.2.1 Tests shall be conducted either on equipment that meets the requirements of PG-73.5.6, or on the boiler, by raising the pressure to demonstrate the set pressure.

PG-73.5.2.2 When the valve is beyond the production test equipment capabilities, an alternative test method presented in PG-73.5.2.2.1 or PG-73.5.2.2.2 may be used, provided all of the following conditions are met:

(a) testing the valve at full pressure may cause damage to the valve, or testing of the valve is impractical due to boiler system operational safety considerations

(b) the valve lift has been mechanically verified to meet or exceed the required lift

(c) the blow down control elements of the safety valve are set to the valve manufacturer's specification

(d) the valve design is compatible with the alternative test method selected

PG-73.5.2.2.1 The valve, with its lift temporarily restricted during the test, if required to prevent valve damage, shall be tested on steam to demonstrate set pressure.

PG-73.5.2.2.2 The valve may be fitted with a hydraulic or

pneumatic lift assist device and tested on steam at a pressure less than the valve set pressure. The lift assist device and test procedure shall be calibrated to provide the set pressure setting within the tolerance of PG-72.2.

PG-73.5.3 Leak Test

(a) A seat tightness test shall be conducted at maximum expected operating pressure but at a pressure not exceeding the reseating pressure of the valve. When being tested, a valve exhibiting no sign of leakage shall be considered adequately tight.

(b) Closed bonnet pressure relief valves designed for discharge to a closed system shall be tested with a minimum of 30 psig (200 kPa) air or other gas in the secondary pressure zone. There shall be no sign of leakage.¹¹

¹¹ The user may specify a higher test pressure commensurate with the back pressure anticipated in service.

PG-73.5.4 A manufacturer or assembler shall have a documented program for the application, calibration, and maintenance of test gages.

PG-73.5. Testing time on steam valves shall be sufficient to assure that test results are repeatable and representative of field performance.

PG-73.5.6 Test fixtures and test drums, where applicable, shall be of adequate size and capacity to assure that the observed set pressure is consistent with the stamped set pressure within the tolerance required by PG-72.2.

PG-73.6 Design Requirements. At the time of submission of valves for capacity certification or testing in accordance with PG-69, the ASME designee has the authority to review design for conformity with the requirements of this Section and to reject or require modification of designs that do not conform, prior to capacity testing.

PG-73.7 Code Symbol "V" Stamp. Each pressure relief valve to which the Code "V" symbol (see Fig. PG-105.4) will be applied shall have been fabricated or assembled by a manufacturer or assembler holding a valid Certificate of Authorization (PG-105.2) and capacity certified in accordance with the requirements of this Section. A Certified Individual (CI) shall provide oversight to assure that each use of the Code "V" symbol on a pressure relief valve is in accordance with the requirements of this Section, and that each use of the Code "V" symbol is documented on a Certificate of Conformance, Form P-8.

PG-73.7.1 Requirements for the Certified Individual (CI). The CI shall

(a) be an employee of the manufacturer or assembler

(b) be qualified and certified by the manufacturer or assembler. Qualifications shall include as a minimum

(1) knowledge of the requirements of this Section for the application of the Code "V" symbol

(2) knowledge of the manufacturer's or assembler's quality program

(3) training commensurate with the scope, complexity, or special nature of the activities to which oversight is to be provided

(c) have a record, maintained and certified by the manufacturer or assembler, containing objective evidence of the qualifications of the CI and the training program provided

PG-73.7.2 Duties of the Certified Individual (CI). The CI shall

(a) verify that each item to which the Code "V" symbol is applied has a current capacity certification and meets all applicable requirements of this Section

(b) review documentation for each lot of items to be stamped to verify, for the lot, that requirements of this Section have been completed

(c) sign the Certificate of Conformance, Form P-8, prior to release of control of the pressure relief valves

PG-73.7.3 Certificate of Conformance, Form P-8

(a) The Certificate of Conformance, Form P-8, shall be filled out by the manufacturer or assembler and signed by the Certified Individual. Multiple duplicate pressure relief valves may be recorded as a single entry, provided the valves are identical and are produced in the same lot.

(b) The manufacturer's or assembler's written quality control program shall include requirements for completion of Certificates of Conformance, Form P-8, and retention, by the manufacturer or assembler, for a minimum of 5 years.

FABRICATION

PG-75 GENERAL

The fabrication of boilers and parts thereof shall conform to the general fabrication requirements in the following paragraphs and in addition to the specific requirements for fabrication in the Parts of this Section that pertain to the methods of construction used.

PG-76 CUTTING PLATES AND OTHER STOCK

PG-76.1 Plates may be cut by machining, punching, shearing, or cutting by the electric arc or gas process, providing enough metal is left at any unfinished edges to meet the requirements of PG-79.

PG-76.2 When end faces of nozzle or manhole necks are to remain unwelded in the completed vessel, these end faces shall not be cut by shearing unless at least 1/8 in. (3 mm) of additional metal is removed by any method that will produce a smooth finish.

PG-91 QUALIFICATION OF INSPECTORS

The inspection required by this Section shall be by an Inspector employed by an ASME accredited Authorized Inspection Agency,¹² that is, the inspection organization of a state or municipality of the United States, a Canadian province, or of an insurance company authorized to write boiler and pressure vessel insurance. These Inspectors shall have been qualified by written examination under the rules of any state of the United States or province of Canada which has adopted the Code.

¹² Whenever *Authorized Inspection Agency* or *AIA* is used in this Code, it shall mean an Authorized Inspection Agency accredited by ASME in accordance with the requirements in the latest edition of ASME QAI-1, Qualification for Authorized Inspection.

PG-93 INSPECTION AND REPAIR OF FLAT PLATE IN CORNER JOINTS

PG-93.1 When flat plate greater than 1/2 in. (13 mm) thickness is welded to other pressure parts to form a corner joint, such as in flat heads [Fig. PG-31, illustrations (g), (i-1), and (i-2)], waterlegs of firebox boilers or combustion chambers of wetback boilers [Fig. A-8, illustrations (l), (m), (n), and (p)], and the exposed edges of the plate are closer to the edge of the weld than a distance equal to the thickness of the plate, the peripheral plate edges and any remaining edges and any remaining exposed surface of the weld joint preparation shall be examined after welding by either the magnetic particle or liquid penetrant method. When the plate is nonmagnetic, only the liquid penetrant method shall be used. The requirements of this paragraph shall not apply to those joints when 80% or more of the pressure load is carried by tubes, stays, or braces, or when the exposed

edges of the plate are farther from the edge of the weld than a distance equal to the thickness of the plate.

PG-93.2 Laminations, cracks, or other imperfections found during the examination required by PG-93.1 that would affect the safety of the vessel shall be repaired in accordance with PG-78. The imperfection(s) may be pursued by any suitable method (grinding, chipping, etc.). The repaired area shall be subjected to the same examination that first revealed the imperfection.

PG-93.3 Methods and acceptance criteria for magnetic particle and liquid penetrant examination shall be in accordance with A-260 or A-270, respectively.

PG-99 HYDROSTATIC TEST

Hydrostatic testing of the completed boiler unit shall be conducted in accordance with the following requirements:

After a boiler has been completed (see PG-104), it shall be subjected to pressure tests using water at not less than ambient temperature, but in no case less than 70°F (20°C). Where required, test pressures are specified in this paragraph; whether minimum or maximum pressures, they apply to the highest point of the boiler system. When the boiler is completed in the Manufacturer's shop without boiler external piping, subsequent hydrostatic testing of the boiler external piping shall be the responsibility of any holder of a valid "S," "A," or "PP" stamp. The safety valves need not be included in the hydrostatic test. The tests shall be made in two stages in the following sequence:

PG-99.1 Hydrostatic pressure tests shall be applied by raising the pressure gradually to not less than 1 1/2 times the maximum allowable working pressure as shown on the data report to be stamped on the boiler. No part of the boiler shall be subjected to a general membrane stress greater than 90% of its yield strength (0.2% offset) at test temperature. The primary membrane stress to which boiler components are subjected during hydrostatic test shall be taken into account when designing the components. Close visual inspection for leakage is not required during this stage.

PG-99.2 The hydrostatic test pressure may then be reduced to the maximum allowable working pressure, as shown on the Data Report, to be stamped on the boiler and maintained at this pressure while the boiler is carefully examined. The metal temperature shall not exceed 120°F (50°C) during the close examination.

PG-99.3 A completed forced-flow steam generator with no fixed steam and waterline, having pressure parts designed for different pressure levels along the path of water-steam flow, shall be subjected to a hydrostatic pressure test by the above procedure (PG-99.1 and PG-99.2) based upon:

PG-99.3.1 For the first stage test (PG-99.1) a hydrostatic test pressure of not less than 1 1/2 times the maximum allowable working pressure at the superheater outlet as shown in the master stamping (PG-106.3) but not less than 1 1/4 times the maximum allowable working pressure of any part of the boiler, excluding the boiler external piping.

PG-99.3.2 For the second stage test (PG-99.2) the hydrostatic test pressure may be reduced to not less than the maximum allowable working pressure at the superheater outlet.

PG-99.4 Test Gages

PG-99.4.1 An indicating gage, visible to the operator controlling the pressure applied, shall be connected to the pressure parts. Hydrostatic head on the gage shall be considered such that the required test pressure is achieved at the top of the boiler.

PG-99.4.2 Dial pressure gages used in testing shall prefer-

ably have dials graduated over their entire range of about double the intended maximum test pressure, but in no case shall the range be less than 1 ½ times that pressure. The spacing between graduations shall be such that the inspector and the operator controlling the test shall be able to determine when the required test pressure has been applied. Digital pressure gages having a wider range of pressure readings may be used provided the readings give the same or greater degree of accuracy as obtained with dial pressure gages.

PG-100 HYDROSTATIC DEFORMATION TEST

Where no rules are given and it is impossible to calculate with a reasonable degree of accuracy the strength of a boiler structure or any part thereof, a full-sized sample shall be built by the Manufacturer and tested in accordance with the Standard Practice for Making a Hydrostatic Test on a Boiler Pressure Part to Determine the Maximum Allowable Working Pressure, given in A-22 or in such other manner as the Committee may prescribe.

CERTIFICATION BY STAMPING AND DATA REPORTS

PG-101 HEATING SURFACE COMPUTATION

PG-101.1 For the stamping required by PG-106, the heating surface shall be computed as specified in PG-101.1.1 through PG-101.1.3.

PG-101.1.1 Heating surface, as part of a circulating system in contact on one side with water or wet steam being heated and on the other side with gas or refractory being cooled, shall be measured on the side receiving heat.

PG-101.1.2 Boiler heating surface and other equivalent surface outside the furnace shall be measured circumferentially plus any extended surface.

PG-101.1.3 Waterwall heating surface and other equivalent surface within the furnace shall be measured as the projected tube area (diameter x length) plus any extended surface on the furnace side. In computing the heating surface for this purpose, only the tubes, fireboxes, shells, tubesheets, and the projected area of headers need to be considered, except that for vertical firetube steam boilers only that portion of the tube surface up to the middle of the gage glass is to be computed.

PG-104 GENERAL

PG-104.1 The completed boiler unit includes all piping and piping components as defined in the Introduction.

The Manufacturer [see Note (1) below] of any complete boiler unit to be stamped with the Code symbol has the responsibility of assuring through proper Code certification that all work performed by him or others responsible to him complies with all requirements of the Code, including design, construction, materials, and workmanship. With the exception of field installed boiler external piping, when some portions of a complete boiler unit are supplied by, or Code work is performed by others not responsible to the Manufacturer, the Manufacturer has the duty of obtaining from these other organizations their proper Code certification, covering such portions of work.

When the Manufacturer furnishes a shop assembled boiler that is complete except for boiler external piping, and the boiler has been hydrostatically tested in the shop and properly stamped with the Manufacturer's "S" symbol, the subsequent installation in the field of the external piping within the scope of Section I is not by itself considered "field assembly of the boiler" [see Note (2) below].

No Manufacturer or assembler may accept Code responsibil-

ity for work that falls within the scope of the Code, that is performed by workmen employed by any other organization, except through proper Code certification. The responsibilities set forth herein relate only to Code compliance and are not to be construed as involving contractual relations or legal liabilities.

NOTES: (1) Boiler Manufacturer or Manufacturer as used in PG-104 or other paragraphs referenced to this Note may also be an Engineering Contractor organization with or without fabricating facilities, but having the capability of providing a design specification that establishes the pressure and temperature conditions for each component of a complete boiler unit and of assembling the fabricated parts in the field with authorization from the Society to use the Code symbol stamp "S" in accordance with the Code provisions in PG-105.3.

(2) When boiler external piping within the scope of Section I is furnished by other than the boiler Manufacturer, the boiler Manufacturer is not responsible for the Code certification of such piping. The organizations that furnish and that install such external piping by welding shall furnish proper Code certification (PG-104.2) for such piping including Manufacturers' Data Report Form P-4A as required by PG-112.2.5 and PG-112.3.

PG-104.2 Proper Code certification refers to the furnishing of stamping and Data Reports as evidence to establish the following.

PG-104.2.1 The organization that performed that portion of the work held an appropriate Certificate of Authorization.

PG-104.2.2 By signing and furnishing the appropriate data report, that organization certified compliance with Code rules for that portion of the work.

PG-104.2.3 By proper use of the Code symbol stamp, that organization identified the portions of the work covered by its Data Report Form.

PG-104.2.4 By countersignature on the same Data Report a qualified Inspector confirmed that portion of the work complied with applicable Code rules.

PG-105 CODE SYMBOL STAMPS

PG-105.1 Authorization. Except as permitted in PG-105.5, no organization may assume responsibility for Code construction without having first received from the ASME Certificate of Authorization to use one of the Code symbol stamps shown in Figs. PG-105.1 through PG-105.4. There are six such stamps, defined as follows:

- (a) S - power boiler symbol stamp (see Fig. PG-105.1)
- (b) M - miniature boiler symbol stamp (see Fig. PG-105.1)
- (c) E - electric boiler symbol stamp (see Fig. PG-105.1)
- (d) A - boiler assembly symbol stamp (see Fig. PG-105.2)
- (e) PP - pressure piping symbol stamp (see Fig. PG-105.3)
- (f) V - safety valve symbol stamp (see Fig. PG-105.4)

Stamps for applying the Code symbol shall be obtained from the Society. Each boiler, superheater, waterwall, economizer, or boiler part to which a Code symbol is to be applied shall be fabricated by a Manufacturer who is in possession of an appropriate Code symbol stamp. A Certificate of Authorization to use the Code symbol "S," "M," "E," "A," "PP," or "V" stamp will be granted by the Society pursuant to the provisions of these paragraphs.



FIG. PG-105.4 OFFICIAL SYMBOL FOR STAMP TO DENOTE THE AMERICAN SOCIETY OF MECHANICAL ENGINEERS' STANDARD FOR BOILER PRESSURE RELIEF VALVES

FIG. PG-105.1 OFFICIAL SYMBOLS FOR STAMPS TO DENOTE THE AMERICAN SOCIETY OF MECHANICAL ENGINEERS' STANDARD FOR BOILERS



FIG. PG-105.2 OFFICIAL SYMBOL FOR STAMP TO DENOTE THE AMERICAN SOCIETY OF MECHANICAL ENGINEERS' STANDARD FOR ASSEMBLY



FIG. PG-105.3 OFFICIAL SYMBOL FOR STAMP TO DENOTE THE AMERICAN SOCIETY OF MECHANICAL ENGINEERS' STANDARD FOR WELDED PIPING



PG-109 STAMPING OF PRESSURE PIPING

PG-109.1 Boiler external piping, as defined in the Introduction, may be fabricated by a manufacturer other than the Manufacturer of the boiler, provided that the manufacturer has been issued a Certificate of Authorization to use the "S" or "PP" symbol stamp. Boiler external piping may be installed by welding by a manufacturer or contractor other than the Manufacturer of the boiler, provided such an organization has been issued a Certificate of Authorization to use the "S," "PP," or "A" symbol stamp. When boiler external piping is installed by welding, the welding, including the qualification of welding procedures, welders, and welding operators, shall be done in accordance with the applicable rules of ASME B31.1. The welding shall be inspected by an Authorized Inspector at such stages of the work as he may elect. The organizations which fabricate or install such piping shall furnish proper code certification (PG-104.2) for it including a Manufacturer's Data Report Form P-4A as required by PG-112.2.5 and PG-112.3.

PG-109.2 Welded boiler external piping included within the scope of this Code, over NPS 2 (DN 50), shall be stamped with a Code symbol, together with the manufacturer's or contractor's name and serial number. Such stamping shall be on the pipe, valve or fitting adjacent to the welded joint farthest from the boiler. For piping operating at temperatures above 800° F (425° C) the symbol may be stamped on a nameplate that is irremovably attached by welding, provided such welding is postweld heat treated, or on a circular metal band at least ¼ in. (6 mm) thick. This band around the pipe shall be secured in such a manner as to prevent it from slipping off during handling and installation.

Welded piping NPS 2 (DN 50) or less included within the scope of this Code shall be marked with an identification acceptable to the Inspector and traceable to the required Data Report. Such marking shall be of a type that will remain visible until the piping has been installed.

PG-109.3 A manufacturer in possession of the pressure piping symbol stamp may

(a) design and fabricate welded piping. Such fabrications shall be stamped and reported on a Form P-4A, Manufacturer's Data Report for Fabricated Piping, as called for in PG-112.2.5.

(b) fabricate other parts of boilers, such as superheater, waterwall, or economizer headers, where complete design requirements are provided by others. Such parts shall be stamped or marked as required by PG-106.8 and reported on a Form P-4, Manufacturer's Partial Data Report, as called for in PG-112.2.4.

PG-109.4 Mechanically assembled boiler external piping which contains no pressure boundary welds does not require stamping, and as such may be assembled by a non-stamp holder. Note that the responsibility for documentation and hydrostatic testing of a mechanically assembled boiler external piping must be assumed by a holder of a valid "S," "A," or "PP" stamp (see PG-112.2.5).

PG-110 STAMPING OF BOILER PRESSURE RELIEF VALVES

Each pressure relief valve shall be plainly marked with the required data by the Manufacturer or Assembler (see PG-73.4.4) in such a way that the marking will not be obliterated in service. The marking shall be placed on the valve or on a nameplate securely fastened to the valve. The Code "V" symbol shall be stamped on the valve or nameplate by the Manufacturer or Assembler, as applicable. The other required data may be stamped, etched, impressed, or cast on the valve or nameplate. For units other than those included below, see PG-4. The marking shall include the following:

- (a) the name (or an acceptable abbreviation) of the Manufacturer and Assembler, as applicable
- (b) Manufacturer's design or type number
- (c) NPS (DN) (the nominal pipe size of the valve inlet)
- (d) set pressure __ psi (MPa)
- (e) *Capacity*
 - (1) capacity __ lb/hr (kg/hr) (for saturated steam service in accordance with PG-69.2) or
 - (2) capacity __ lb/hr (kg/hr) at __ °F (°C) (for superheated steam service in accordance with PG-68.7 or supercritical steam service in accordance with PG-69.2.3) or
 - (3) capacity __ gal/min (l/min) at 70°F (20°C) and lb/hr (kg/hr) steam for economizer service in accordance with PG-69.2

(f) year built, or alternatively, a coding may be marked on the valve such that the valve Manufacturer or Assembler can identify the year the valve was assembled and tested

(g) ASME symbol as shown in Fig. PG-105.4

(h) The pilot of a pilot-operated pressure relief valve shall be plainly marked by the Manufacturer or Assembler showing the name of the Manufacturer, the Manufacturer's design or type number, the set pressure in pounds per square inch (MPa), and the year built, or alternatively, a coding that the Manufacturer can use to identify the year built.

PG-111 LOCATION OF STAMPINGS

The location of the required stampings shall be as listed below. These stampings shall be left uncovered or an easily removable marked cover may be provided over the stamping when a boiler is covered with insulation, or jacketed. No piping, boiler appliance, or other obstructions shall interfere with reading of the stamping.

PG-111.1 Horizontal-return tubular boilers – on the front head above the central rows of tubes.

PG-111.2 Horizontal-flue boilers – on the front head above the flues.

PG-111.3 Traction, portable, or stationary boilers of the locomotive type or Star watertube boilers – on the furnace end above the handhole. Or on traction boilers of the locomotive type – on the left wrapper sheet forward of the driving wheel.

PG-111.4 Vertical firetube and vertical submerged tube boilers – on the shell above the firedoor and handhole opening.

PG-111.5 Watertube Boilers

PG-111.5.1 Drum type – on a head of the steam outlet drum near and above the manhole.

PG-111.5.2 Forced-flow steam generator with no fixed steam and waterline – the master stamping (PG-106.3) shall be located on a major pressure part, located near the main operating floor where readily visible. The Data Report Form shall record the location of the master stamping.

PG-111.6 Scotch marine boilers – on either side of the shell near the normal water level line and as near as practical to the front tubesheet.

PG-111.7 Economic boilers – on the front head, above the center row of tubes.

PG-111.8 Miniature and electric boilers – on some conspicuous and accessible place on the boiler proper, or on a stamping plate at least 3/64 in. (1.2 mm) thick, permanently fastened (adhesives prohibited) to the boiler.

PG-111.9 On any of the above types where there is not sufficient space in the place designated, and for other types and new designs – in a conspicuous place on the boiler proper. The Data Report Form shall record the location of the required stamping.

PG-111.10 Superheaters – on superheater header near the outlet. Other headers shall carry identifying marks.

PG-111.11 Economizers – at a handy location on water inlet header or drums. Other headers shall carry identifying marks.

PG-111.12 Waterwalls – on one end of a lower header. Other headers shall carry identifying marks.

PG-111.13 When required by PG-106.6 and PG-106.7, the Manufacturer [see PG-104, Note (1)] shall furnish a nameplate or plates on which the appropriate Code Symbol and design data for the scope of his responsibility are permanently imprinted. The nameplate shall be securely attached to the front of the boiler, its setting or casing, at a place readily visible from the operating floor or platform.

PG-112 MANUFACTURERS' DATA REPORT FORMS

PG-112.1 Ten types of Manufacturers' Data Report Forms are shown in the Appendix under the heading "Data Report Forms and Guides" at the end of this Section. These forms shall be used by the Manufacturer [see PG-104, Note (1)] to record all the items of a complete boiler unit, in accordance with the provisions of PG-112.2. When the certification of the complete boiler unit is accomplished by more than one Data Report, the principal Data Report (P-2, P-2A, P-3, or P-3A) shall be designated as the Master Data Report (see PG-113).

For forced-flow steam generators with no fixed steam and waterline consisting of groups of pressure parts or components designed at several different pressure levels, a separate Manufacturers' Data Report shall clearly identify the pressure parts at each pressure level and show the maximum allowable working pressure. These several Data Reports shall be attached to a

Master Data Report (PG-113) that shall clearly identify each component as part of the complete unit.

PG-112.2 Types of Data Report Forms. The types of Data Report Forms and the purposes for which they are to be used are specified in PG-112.2.1 through PG-112.2.8.

PG-112.2.1 Form P-2, Manufacturers' Data Report for All Types of Boilers Except Watertube and Electric, shall be used to record all types of boilers other than watertube boiler units and parts thereof, which are included under Form P-3.

PG-112.2.1.1 Form P-2A, Manufacturers' Data Report for All Types of Electric Boilers, shall be used to record all types of electric boilers.

PG-112.2.1.2 Form P-2B, Manufacturers' Data Report for Electric Superheaters and Reheaters, shall be used to record electric superheaters and reheaters installed external to the boiler setting.

PG-112.2.2 Form P-3, Manufacturers' Data Report for Watertube Boilers, Superheaters (except electric), Waterwalls, and Economizers, shall be used to record all of the items comprising a watertube boiler.

The Form P-3 shall also be used to record a superheater, waterwall, or economizer when the design of such an item is certified by a manufacturer other than the boiler Manufacturer, or when such an item is to be added to an existing boiler. The item shall be stamped with the ASME "S" symbol and the additional information, as applicable, shown in PG-106.4.2.

Item 10 on Form P-3 shall be used to record other parts connected at the openings listed in Item 11 if such parts are fabricated of materials or by processes that require Code inspection. If such parts have not been connected prior to the hydrostatic test, a notation shall be made under Item 10 reading: "No parts connected to the openings listed in Item 11 except as noted."

PG-112.2.3 Form P-3A, Engineering-Contractor Data Report for a Complete Boiler Unit, shall be used when such an organization assumes the Manufacturer's Code responsibility as provided for by PG-104, Note (1). This form shall be used to certify Code responsibility for the design specification of the complete boiler unit, of which the components are individually certified by their individual manufacturers in accordance with the Code rules. This form also provides for field assembly certification.

PG-112.2.4 Form P-3A shall not be used by a Manufacturer to provide Code certification for only a portion of the complete boiler unit.

PG-112.2.5 Form P-4A, Manufacturers' Data Report for Fabricated Piping, shall be used to record all shop or field-welded piping that falls within the scope of this Section but is not furnished by the boiler Manufacturer. Form P-4B, Manufacturers' Data Report for Field Installed Mechanically Assembled Piping, shall be used to record all field installed mechanically assembled boiler external piping. Form P-4B shall be used only for piping that contains no joints brazed or welded by the field installer.

PART PFT

REQUIREMENTS FOR FIRETUBE BOILERS

GENERAL

PFT-1 GENERAL

The rules in Part PFT are applicable to firetube boilers and parts thereof and shall be used in conjunction with the general requirements in Part PG as well as with the specific require-

ments in the applicable Parts of this Section that apply to the method of fabrication used.

MATERIALS

PFT-5 GENERAL

PFT-5.1 Materials used in the construction of pressure parts for firetube boilers shall conform to one of the specifications given in Section II and shall be limited to those for which allowable stress values are given in Tables 1A and 1B of Section II, Part D, or as otherwise specifically permitted in Parts PG and PFT.

PFT-5.2 Waterleg and doorframe rings of vertical firetube boilers and of locomotive and other type boilers shall be of wrought iron or steel, or cast steel as designated in the SA-216. The ogee or other flanged construction may be used as a substitute in any case.

DESIGN

PFT-8 GENERAL

The rules in the following paragraphs apply specifically to the design of firetube boilers and parts thereof and shall be used in conjunction with the general requirements for design in Part PG as well as with the specific requirements for design in the applicable Parts of this Section that apply to the method of fabrication used.

PFT-9 THICKNESS REQUIREMENTS

PFT-9.1 Shell and Dome. The thickness after forming shall be as determined in accordance with the rules in Part PG.

PFT-9.2 Tubesheet

PFT-9.2.1 The thickness shall be as determined in accordance with Part PG and Part PFT.

PFT-9.2.2 When butt welded to the shell of a firetube boiler, a formed tubesheet with a straight flange longer than 1 ½ times the tubesheet thickness shall have a straight flange thickness not less than that specified in the table in PFT-9.2.1, but in no case less than 0.75 times the thickness of the shell to which it is attached.

PFT-10 SHELL JOINTS

Longitudinal and circumferential welded joints of a shell or drum shall comply with the rules in Part PW.

PFT-11 ATTACHMENT OF HEADS AND TUBESHEETS

Flat heads and tubesheets of firetube boilers shall be attached by one of the following methods.

PFT-11.2 By flanging and butt welding in accordance with Parts PG and PW.

PFT-11.3 By attaching an outwardly or inwardly flanged tubesheet to the shell by fillet welding provided the following requirements are met.

PFT-11.3.1 The tubesheet is supported by tubes, or stays, or both.

PFT-11.3.2 The joint attaching an outwardly flanged tubesheet is wholly within the shell and forms no part thereof.

PFT-11.3.3 Inwardly flanged tubesheets are full fillet welded inside and outside.

PFT-11.3.4 The throat dimension of the full fillet weld is equal to not less than 0.7 of the thickness of the head.

PFT-11.3.5 The shell at the welds is not in contact with primary furnace gases.¹³

¹³Primary furnace gases are those in a zone where the design temperature of those gases exceeds 850°F (455°C).

PFT-11.3.6 The construction conforms in all other respects to the requirements of this Section, including welding and post-weld heat treating, except that volumetric examination is not required.

PFT-11.3.7 This construction shall not be used on the rear head of a horizontal-return tubular boiler and inwardly flanged tubesheets shall not be used on a boiler with an extended shell.

PFT-11.3.8 On inwardly flanged tubesheets, the length of flange shall conform to the requirements of PW-13 and the distance of the outside fillet weld to the point of tangency of the knuckle radius shall be not less than ¼ in. (6 mm).

PFT-11.4 By attaching an unflanged tubesheet to the shell by welding, provided the requirements of PFT-11.4.1 through PFT-11.4.7 are met.

PFT-11.4.1 The tubesheet is supported by tubes, or stays, or both.

PFT-11.4.2 The welded joint may be made through the tubesheet or shell thickness. When the weld joint is made through the shell, a minimum of 80% of the pressure load shall be carried by the tubes, stays, or both.

PFT-11.4.3 The weld is a full penetration weld equal at least to the full thickness of the base metal applied from either or both sides. When the full penetration weld is made through the shell, an external fillet weld with a minimum throat of ¼ in. (6mm) shall be provided, and no weld prep machining shall be performed on the flat tubesheet. The distance from the edge of the completed weld to the peripheral edge of the tubesheet shall not be less than the thickness of the tubesheet.

PFT-11.4.4 The shell or wrapper sheet, where exposed to primary furnace gases¹⁴ and not water cooled, does not extend more than 1/8 in. (3 mm) beyond the outside face of the tubesheet.

¹⁴Primary furnace gases are those in a zone where the design temperature of those gases exceeds 850°F (455°C).

PFT-11.4.5 The weld attaching a furnace or a lower tubesheet of a vertical firetube boiler to the furnace sheet is wholly within the furnace sheet and is ground flush with the upper or water side of the tubesheet.

PFT-11.4.6 The construction conforms in all other aspects to the requirements of this Section including welding, and post-weld heat treatment, except that volumetric examination is not required.

PFT-11.4.7 This construction shall not be used on the rear head of a horizontal-return tubular boiler.

PFT-12 TUBES

PFT-12.1 Allowable Working Pressure

PFT-12.1.1 The maximum allowable working pressure of tubes or flues of firetube boilers shall be as given in PFT-50 and PFT-51.

PFT-12.1.2 The maximum allowable working pressure for copper tubes or nipples subjected to internal or external pressure shall not exceed 250 psi (1.7 MPa). The maximum temperature shall not exceed 406° F (208° C).

FIG. PFT-12.1 SOME ACCEPTABLE FORMS OF TUBE ATTACHMENT ON FIRE TUBE BOILERS

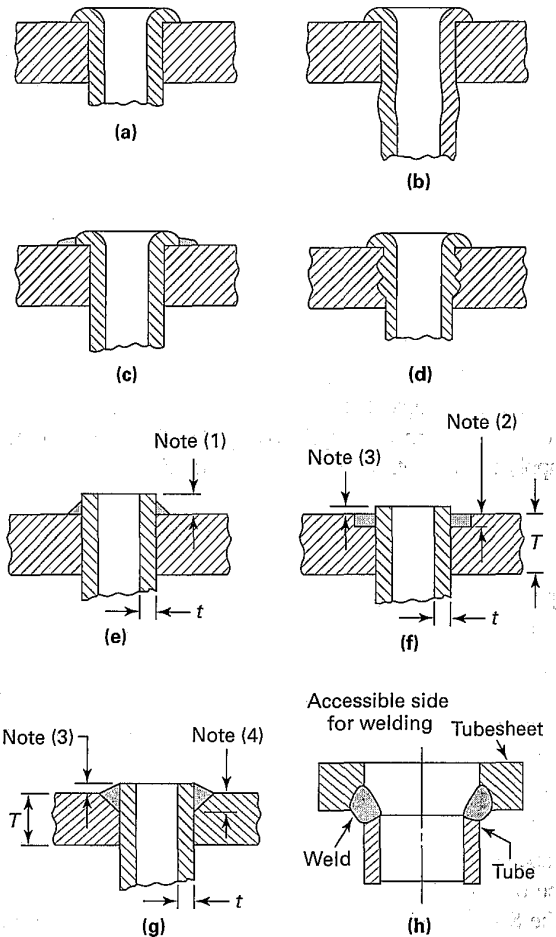

NOTES:

- (1) Not less than t or $\frac{1}{8}$ in. (3 mm), whichever is the greater, nor more than $2t$ or $\frac{1}{4}$ in. (6 mm), whichever is the lesser.
- (2) Not less than t or $\frac{1}{8}$ in. (3 mm), whichever is the greater, nor more than $7/3$ (see PFT-12.2.1.2).
- (3) Not more than t .
- (4) Not less than t or $\frac{1}{8}$ in. (3 mm), whichever is the greater, nor more than $7/3$ (see PFT-12.2.1.2).

The maximum allowable working pressure for copper clad tubes subjected to external pressure shall be determined by the formula in PFT-51, in which t may be increased by one-half the thickness of the cladding.

PFT-12.2 Attachment of Tubes

PFT-12.2.1 Figure PFT-12.1 illustrates some of the acceptable types of tube attachments. Such connections shall be

- (a) expanded and beaded as in illustrations (a), (b), and (d)
- (b) expanded and beaded and seal welded as in illustration (c)
- (c) expanded and seal welded as in illustration (e)
- (d) welded, as in illustrations (f) and (g)

Tube ends attached by expanding and welding are subject to the provisions specified in PFT-12.2.1.1 through PFT-12.2.1.3.

PFT-12.2.1.1 Where no bevel or recess is employed, the tube shall extend beyond the tubesheet not less than a distance

equal to the tube thickness or $\frac{1}{8}$ in. (3 mm), whichever is the greater, nor more than twice the tube thickness or $\frac{1}{4}$ in. (6 mm), whichever is the lesser [see Fig. PFT-12.1, illustration (e)].

PFT-12.2.1.2 The tubesheet hole may be beveled or recessed. The depth of any bevel or recess shall not be less than the tube thickness or $\frac{1}{8}$ in. (3 mm), whichever is greater, nor more than one-third of the tubesheet thickness, except that when tube thicknesses are equal to or greater than 0.150 in. (4 mm), the bevel or recess may exceed $T/3$. Where the hole is beveled or recessed, the projection of the tube beyond the tubesheet shall not exceed a distance equal to the tube wall thickness [see Fig. PFT-12.1, illustrations (f) and (g)].

PFT-12.2.1.3 On types of welded attachment shown in Fig. PFT-12.1, illustrations (c) and (e), the tubes shall be expanded before and after welding. On types shown in illustrations (f) and (g), the tubes may be expanded.

PFT-12.2.2 Expanding of tubes by the Prosser method may be employed in combination with any beaded or seal welded attachment method [see Fig. PFT-12.1, illustration (b)].

PFT-12.2.3 After seal welding as shown by Fig. PFT-12.1, illustrations (c) and (e), a single hydrostatic test of the boiler shall suffice.

PFT-12.2.4 The inner surface of the tube hole in any form of attachment may be grooved or chamfered.

PFT-12.2.5 The sharp edges of tube holes shall be taken off on both sides of the plate with a file or other tool.

DOORS AND OPENINGS

PFT-40 WELDED DOOR OPENINGS

Arc or gas welding may be used in the fabrication of door holes provided the sheets are stayed around the opening in accordance with the requirements of PFT-27.6 and PFT-27.7.

No calculations need be made to determine the availability of compensation for door openings spanning between the plates of waterlegs. The required thickness of circular access openings shall be determined in accordance with PFT-51. The required thickness of door openings of other than circular shape shall be calculated using eq. (1) of PG-46, using 2.1 or 2.2 for the value of C , depending on the plate thickness, and a value of p equal to the waterleg inside width. Volumetric examination of the joining welds is not required.

PFT-41 OPENINGS IN WRAPPER SHEETS

Openings located in the curved portion of the wrapper sheet of a locomotive type boiler shall be designed in accordance with the rules in PG-32.

PFT-42 FIRESIDE ACCESS OPENINGS

The minimum size of an access or fire door opening, in which the minimum furnace dimension is 24 in. (600 mm), shall be not less than 12 in. x 16 in. (300 mm x 400 mm) or equivalent area, 11 in. (280 mm) to be the least dimension in any case. A circular opening shall be not less than 15 in. (380 mm) in diameter.

For furnace dimensions less than 24 in. (600 mm), the opening should be $2\frac{3}{4}$ in. x $3\frac{1}{2}$ in. (70 mm x 89 mm) or larger where possible. In cases where the size or shape of the boiler prohibits an opening of that size, two openings with a minimum size of 1 in. (25 mm) may be used, preferably opposite each other, to permit inspection and cleaning of the furnace. If the burner is removable so as to permit inspection and cleaning through the burner opening, a separate access opening need not be provided.

The bonnet or smoke hood of a vertical flue or tubular boiler

shall be provided with an access opening at least 6 in. x 8 in. (150 mm x 200 mm) for the purpose of inspection and cleaning the top head of the boiler.

PFT-43 REQUIREMENTS FOR INSPECTION OPENINGS

All firetube boilers shall have sufficient inspection openings, handholes, or washout plugs with a minimum of four openings to permit inspection of the waterside of the tubesheets, furnaces, and tubes and to permit flushing of loose scale and sediment from the boiler. Except where space restrictions would prohibit entry to the boiler, a manhole shall be provided in the upper portion of the shell. All openings shall meet the requirements of PG-32 through PG-44. Where washout plugs are used, the minimum size shall be NPS 1½ (DN 40), except for boilers 16 in. (400 mm) or less in inside diameter, the minimum size shall be NPS 1 (DN 25).

PFT-44 OPENING BETWEEN BOILER AND SAFETY VALVE

The opening or connection between the boiler and the safety valve shall have at least the area of the valve inlet.

After the boiler Manufacturer provides for the opening required by the Code, a bushing may be inserted in the opening in the shell to suit a pressure relief valve that will have the capacity to relieve all the steam that can be generated in the boiler and which will meet the Code requirements. The minimum size of the connection and opening for the pressure relief valve shall be not less than NPS ½ (DN 15).

No valve of any description shall be placed between the required pressure relief valve or valves and the boiler, or on the discharge pipe between the pressure relief valve and the atmosphere. When a discharge pipe is used, the cross-sectional area shall be not less than the full area of the valve outlet or of the total of the areas of the valve outlets discharging thereto and shall be as short and straight as possible and so arranged as to avoid undue stresses on the valve or valves.

DOMES

PFT-45 REQUIREMENTS FOR DOMES

PFT-45.1 The longitudinal joint of a dome may be butt welded or the dome may be made without a seam of one piece of steel pressed into shape. The dome flange may be double full fillet lap-welded to the shell if all welding complies fully with the requirements for welding in Part PW. Volumetric examination of the fillet welds may be omitted. The opening shall be reinforced in accordance with PG-32 through PG-44.

PFT-45.3 When a dome is located on the barrel of a locomotive-type boiler or on the shell of a horizontal-return tubular boiler, the outside diameter of the dome shall not exceed six-tenths the inside diameter of the shell or barrel of the boiler unless the portion of the barrel or shell under the dome (the neutral sheet) is stayed to the head or shell of the dome by stays which conform in spacing and size to the requirements given in PG-46 and Table 1A of Section II, Part D. With such stayed construction the outside diameter of a dome located on the barrel or shell of a boiler is limited to eight-tenths of the barrel or shell inside diameter.

PFT-45.4 All domes shall be so arranged that any water can drain back into the boiler.

PFT-45.5 Flanges of domes shall be formed with a corner radius, measured on the inside, of at least twice the thickness of the plate for plates 1 in. (25 mm) in thickness or less, and at least three times the thickness of the plate for plates over 1 in. (25 mm) in thickness.

PFT-45.6 Domes and manhole frames attached to shells or heads of boilers shall be designed in accordance with PG-32 through PG-44.

PART PEB

REQUIREMENTS FOR ELECTRIC BOILERS

GENERAL

PEB-1 GENERAL

The rules in Part PEB are applicable to electric boilers and parts thereof and shall be used in conjunction with the general requirements in Part PG as well as with the special requirements in the applicable Parts of this Section that apply to the method of fabrication used.

PEB-2 SCOPE

PEB-2.1 This part contains special rules for construction of electric boilers, both of the electrode and immersion resistance element type. This Part does not include electric boilers where the heat is applied externally to the boiler pressure vessel by electric resistance heating elements, induction coils, or other electrical means. These types of electric boilers shall be constructed in accordance with other applicable Parts of this Section.

PEB-2.2 Electric boilers and parts thereof that do not exceed the diameter, volume, or pressure limits of PMB-2 may be constructed using the applicable paragraphs of Part PMB in conjunction with this Part.

PEB-2.3 An electrode type boiler is defined as an electric boiler in which heat is generated by the passage of an electric current using water as the conductor.

PEB-2.4 An immersion resistance element type boiler is defined as an electric boiler in which heat is generated by the passage of an electric current through a resistance heating element directly immersed in water, or enclosed in a pipe immersed in water.

PEB-2.5 Electric boilers may be field assembled provided the boiler is manufactured and assembled in compliance with the provisions and requirements of Part PEB and other applicable Parts of this Section.

PEB-3 OPTIONAL REQUIREMENTS FOR THE BOILER PRESSURE VESSEL

The boiler pressure vessel may be constructed in compliance with the ASME Pressure Vessel Code Section VIII, Division 1, rules for unfired steam boilers [UW-2(c)] subject to the conditions specified in PEB-3.1 through PEB-3.4.

PEB-3.1 The Manufacturer who certifies and stamps the completed boiler shall specify to the “U” stamp holder all additional requirements of Part PEB, which are not requirements of Section VIII, Division 1, and shall ensure that these requirements are satisfied.

PEB-3.2 These additional requirements are:

PEB-3.2.1 The materials of construction shall comply with the requirements of PEB-5.1 and PEB-5.3.

PEB-3.2.2 Inspection openings shall comply with the requirements of PEB-10.

PEB-3.3 The boiler pressure vessel shall be stamped with the ASME Code “U” symbol and the letters “UB,” and be documented with the ASME U-1 or U-1A Data Report.

PEB-3.4 The master Data Report P-2A for the Electric Boiler shall indicate “Boiler pressure vessel constructed to Section VIII, Division 1 as permitted by Part PEB.”

MATERIALS

PEB-5 GENERAL

PEB-5.1 Unless specifically permitted elsewhere in this section, materials used in the construction of pressure parts for electric boilers shall conform to one of the specifications in Section II and shall be limited to those permitted by PG-6, PG-7, PG-8, and PG-9 for which allowable stress values are given in Tables 1A and 1B of Section II, Part D. Miscellaneous pressure parts shall conform to the requirements of PG-11.

PEB-5.2 Seamless or welded shells, plates, or heads of electric boilers shall not be less than 3/16 in. (5 mm) in thickness.

PEB-5.3 Electric boilers of the immersion element type may be fabricated of austenitic stainless steel type 304, 304L, 316, 316L, and 347 of any material specification listed in PG-6 and PG-9, provided that a precautionary statement indicating that the boiler shall be operated using only deionized water, having a maximum conductance of 1 microSiemen per cm (1 μ S/cm) [minimum specific resistivity of 1 megohm per cm (1 $M\Omega$ /cm)], is clearly marked on the boiler in a visible location.

DESIGN

PEB-8 GENERAL

PEB-8.1 The rules in the following paragraphs apply specifically to the design of electric boilers and parts thereof. They shall be used in conjunction with the general requirements for design in Part PG, any applicable requirements in Part PMB for miniature boilers, and with the specific requirements for design in applicable Parts of this Section that apply to the method of fabrication used.

PEB-8.2 Responsibility of design of electric boilers to be marked with the "E" symbol shall be that of the holder of the "E" stamp.

PEB-9 WELDING

Electric boilers may be constructed by fusion welding in accordance with all the requirements of this Section except that postweld heat treatment, volumetric examination of the welded joints, and the nondestructive examinations described in PG-93.1 are not required when the limitations in PMB-2.1 are not exceeded.

PEB-10 INSPECTION OPENINGS

PEB-10.1 Electric boilers of a design employing a removable cover, or removable internal electric heating elements that will permit access for inspection, and cleaning and having an internal volume (exclusive of casing and insulation) of not more than 5 ft³ (0.14 m³) need not be fitted with washout or inspection openings.

PEB-10.2 Electric boilers of more than 5 ft³ (0.14 m³) not provided with a manhole, shall have an inspection opening or handhole located in the lower portion of the shell or head. The inspection opening shall not be smaller than NPS 3 (DN 80). In addition, electric boilers of the resistance heating element type designed for steam service shall have an inspection opening or handhole at or near the normal waterline.

PEB-11 FEEDWATER SUPPLY

PEB-11.1 The feedwater source to electric boilers shall be capable of meeting the applicable requirements of PG-61. Feedwater connections to an electric boiler shall not be smaller than NPS 1/2 (DN 15), except as permitted by PMB-11.

PEB-11.2 Electric boilers that do not exceed the diameter, volume, or pressure limits of PMB-2, may have the feedwater delivered through the blowoff opening if desired.

PEB-12 BLOWOFF

PEB-12.1 The blowoff piping for each electric boiler pressure vessel having a normal water content not exceeding 100 gal (380 L) is required to extend through only one valve.

PEB-12.2 The minimum size of blowoff pipes and fittings shall be NPS 1 (DN 25), except that for boilers of 200 kW input or less the minimum size of pipe and fittings may be NPS 3/4 (DN 20). Electric boilers that do not exceed the diameter, volume, or pressure limits of PMB-2 may have blowoff connections in accordance with PMB-12.

PEB-13 WATER LEVEL INDICATORS

PEB-13.1 Electric boilers of the electrode type shall have at least one gage glass. The gage glass shall be located as to indicate the water levels both at startup and under maximum steam load conditions as established by the Manufacturer.

PEB-13.2 Electric boilers of the resistance element type shall have at least one gage glass. The lowest visible water level in the gage glass shall be at least 1 in. (25 mm) above the lowest permissible water level as determined by the Manufacturer. Each electric boiler of this type shall also be equipped with an automatic low-water cutoff on each boiler pressure vessel so located as to automatically cut off the power supply to the heating elements before the surface of the water falls below the visible level in the gage glass.

PEB-13.3 Tubular gage glasses on electric boilers shall be equipped with protective rods or shields.

PEB-14 PRESSURE GAGES

Pressure gages shall meet the requirements of PG-60.6.

PEB-15 PRESSURE RELIEF VALVES

PEB-15.1 Each electric boiler shall have at least one pressure relief valve. Electric boilers with a power input more than 1,100 kW shall have two or more pressure relief valves.

PEB-15.2 The minimum pressure relief valve relieving capacity for electric boilers shall be 3 1/2 lb/hr/kW (1.6 kg/hr/kW) input. The pressure setting shall not be higher than the MAWP stamped on the completed boiler (see PEB-18.3.2).

PEB-15.3 Pressure relief valves shall be mounted in accordance with PG-71.2 with the spindle vertical. Electric boilers that do not exceed the diameter, volume, or pressure limits of PMB-2, may have a pressure relief valve(s) installed in other than the vertical position, provided that

- the valve design is satisfactory for such position
- the valve is not larger than NPS 3/4 (DN 20)
- the maximum angle of deviation from vertical does not exceed 30 deg
- the nozzle location is such that no material that could interfere with the operation of the valve can accumulate at the valve inlet
- the discharge opening of the valve body and discharge piping is oriented so that drainage is adequate

PEB-16 AUTOMATIC DEVICES

Electric boilers shall be provided with pressure and/or temperature controls and an automatic low-water fuel cutoff. No low-water cutoff is required for electrode type boilers.

PEB-17 HYDROSTATIC TEST

PEB-17.1 Each electric boiler pressure vessel shall be hydrostatically tested at completion of fabrication in accordance with PG-99 or PMB-21, as applicable.

PEB-17.2 In addition to the above, after assembly of the boiler pressure vessel and the mechanically assembled boiler external piping and trim, the completed electric boiler shall be given a final hydrostatic test at a pressure not less than 1 1/2

times the MAWP of the pressure vessel. Miniature electric boilers that are trimmed to operate at less than the MAWP of the pressure vessel shall be given a hydrostatic test at a pressure not less than the safety valve setting.

PEB-17.3 When the electric boiler is to be marked with the “E” symbol, the symbol shall be applied after completion of the hydrostatic test of PEB-17.2.

PEB-18 INSPECTION AND STAMPING OF BOILERS

PEB-18.1 Inspection of electric boilers shall be as required by PG-90.1 and PG-90.3. Witness by the Authorized Inspector of the hydrotest required in PEB-17.2 for the completed boiler may be omitted for electric boilers that meet all the following limitations:

- (a) 800 kW maximum per vessel
- (b) 600 V maximum
- (c) mechanically assembled boiler external piping (BEP) only

When the Authorized Inspector does not perform a final inspection of the completed boiler, the Manufacturer or Assembler shall make an equivalent examination. The equivalent examination shall be in accordance with a quality control procedure meeting the requirements of PEB-18.2 and PEB-18.5.

PEB-18.1.1 Electric boilers exceeding the size limitations specified in PEB-18.1, and having only mechanically assembled external piping (BEP) and trim, shall have a final inspection by the Authorized Inspector, who shall also witness the hydrostatic test called for in PEB-17.2.

PEB-18.1.2 For electric boilers having welded or brazed boiler external piping (BEP) or trim, the inspection requirements of PG-90.1 and the hydrostatic test requirements of PG-99 apply.

PEB-18.2 Each electric boiler Manufacturer shall comply with the applicable requirements of PG-104 and PG-105.

PEB-18.2.1 An electric boiler Manufacturer or Assembler applying for or renewing the “E” stamp shall have its facilities and organizations subject to a joint review by its Authorized Inspection Agency and the legal jurisdiction involved (see last paragraph of PG-105.4).

PEB-18.2.2 A Manufacturer or Assembler holding an “E” stamp and assembling units where the final shop inspection is not mandatory (see PEB-18.1), shall be subject to periodic review by its Authorized Inspection Agency. The review shall be conducted on a quarterly basis or more frequently if deemed necessary by the Authorized Inspection Agency. The frequency of this review may be reduced subject to written agreement between the Manufacturer or Assembler and its inspection agency and the written approval of the appropriate legal jurisdiction. However, in no case shall the review be less than once every 6 months.

PEB-18.3 The stamping of electric boilers shall conform to the requirements of PG-106. Completed electric boilers shall be marked with the “S” or “M” symbol by the Manufacturer of the boiler pressure vessel except when the boiler pressure vessel is constructed under the provisions of PEB-3 (see PEB-18.4). When the trim, fixtures and fittings (such as valves), threaded boiler external piping, and appurtenances are connected to an electric boiler by a Manufacturer or Assembler not authorized to apply the “S” or “M” stamp, the boiler assembler shall apply an “E” stamp to the completed assembly. “E” stamp holders are limited to the use of assembly methods that do not require welding or brazing.

PEB-18.3.1 The stamping of the boiler pressure vessel shall be located as called for in PG-111.8 and need not indicate the kW input or the maximum designed steaming capacity.

PEB-18.3.2 The stamping of the complete electric boiler shall be on a separate metallic plate and shall be in accordance with PG-106.4. The MAWP shall be that established by the completed boiler assembler holding the “S,” “M,” or “E” stamp, but in no case higher than the MAWP stamped on the boiler shell. The MAWP shall be listed on Part II of Form P-2A, Manufacturers’ Data Report for All Types of Electric Boilers. This plate shall be located on the assembly so that it is readily visible from the operating floor.

PEB-18.3.3 The stamping required by PEB-18.3.2 need not be done in the presence of the Authorized Inspector for electric boilers that do not receive final inspection by the Authorized Inspector (see PEB-18.1).

PEB-18.4 For boiler pressure vessels constructed under the provisions of PEB-3, the inspection and stamping requirements of Section VIII, Division 1, UG-116(c) for special service pressure vessels (UB), shall be followed.

PEB-18.5 Those Manufacturers and Assemblers providing an equivalent examination of completed electric boilers when final inspection is not witnessed by the Authorized Inspector (see PEB-18.1), shall provide oversight by a Certified Individual (CI).

PEB-18.5.1 A Certified Individual (CI) shall be an employee of the Manufacturer or Assembler and shall be qualified and certified by the Manufacturer or Assembler. Qualifications shall include as a minimum

- (a) knowledge of the requirements of this Section for the application of Code symbols
- (b) knowledge of the Manufacturer’s quality program
- (c) training commensurate with the scope, complexity, or special nature of the activities to which oversight is to be provided

The Manufacturer or Assembler shall maintain a record containing objective evidence of the Certified Individual’s qualifications, training and certification.

PEB-18.5.2 The duties of a Certified Individual (CI) shall be to assure that each use of the Code symbol as permitted in PEB-18.3.3 is in accordance with the requirements of this Section and is documented on the Certificate of Conformance on Form P-2A, Manufacturers’ Data Report for All Types of Electric Boilers. The CI shall also

- (a) verify that each electric boiler, to which a Code symbol is applied, meets all applicable requirements of this Section
- (b) sign the Certificate of Conformance, Form P-2A, prior to release of control of the boiler

PEB-19 MANUFACTURERS’ DATA REPORT FOR ELECTRIC BOILERS

PEB-19.1 This form consists of two parts. Part I is to be completed by the Manufacturer of the boiler pressure vessel who is the holder of the “S” or “M” stamp and his inspection agency. Part II is to be completed by the Manufacturer or Assembler responsible for the completed electric boiler who shall be authorized to use any of the “S,” “M,” or “E” stamps.

PEB-19.2 When the boiler pressure vessel is constructed by a “U” stamp holder and certified on a U-1 or U-1A Data Report, Part I shall be completed by the “S,” “M,” or “E” stamp holder to the extent indicated in Guide A-351.1.