

Chapter MVD 5

STANDARDS FOR MOTOR VEHICLE EQUIPMENT

MVD 5.05	Applicability of chapter	MVD 5.36	Auxiliary lamps
MVD 5.06	Enforcement of the vehicle equipment requirements	MVD 5.37	Sidemarkers lamps and reflectors
MVD 5.07	Severability	MVD 5.38	Flashing warning lamps
MVD 5.08	Definitions	MVD 5.40	Windshield defroster-defogger
MVD 5.12	Steering and suspension	MVD 5.51	Windshields
MVD 5.14	Tire, wheel and rim	MVD 5.52	Vent, side and rear windows
MVD 5.22	Brakes	MVD 5.54	Windshield wipers
MVD 5.24	Exhaust and fuel systems	MVD 5.56	Mirrors
MVD 5.26	Headlamps	MVD 5.58	Speed indicator and odometer
MVD 5.27	Headlight inspection equipment and procedure	MVD 5.61	Restraining devices and seats
MVD 5.28	Parking lamps	MVD 5.62	Floor pan
MVD 5.29	Front direction signal lamps	MVD 5.63	Bumper, fender and projecting parts
MVD 5.30	Tail lamps	MVD 5.65	Doors, locks and latches
MVD 5.31	Stop lamps	MVD 5.66	Homemade, or reconstructed motor vehicles
MVD 5.32	Rear direction signal lamps	MVD 5.67	Registration and identification
MVD 5.33	Registration plate lamp		
MVD 5.34	Back up lamp		
MVD 5.35	Horn		

History Chapter MVD 5 as it existed on March 31, 1974 was repealed, and a new Chapter MVD 5 was created, Register, March, 1974, No. 219, effective April 1, 1974.

MVD 5.05 Applicability of chapter. This chapter shall apply to all vehicles operated upon Wisconsin highways except implements of husbandry, bicycles and homemade and reconstructed vehicles registered and domiciled in another state. All required equipment shall be maintained in proper working condition and in conformity with this chapter and chapter 347 Wis. Stats. Vehicles originally equipped to meet statutory requirements at the time of manufacture shall not be required to update such equipment to meet increased requirements. Any additional safety related equipment if installed on a vehicle shall be operational.

History: Cr. Register, March, 1974, No. 219, eff. 4-1-74.

MVD 5.06 Enforcement of the vehicle equipment requirements. It shall be illegal to operate or allow to be operated on Wisconsin highways a vehicle that is not in conformity with the requirements of chapter MVD 5, Wis. Adm. Code. Any violations of chapter MVD 5, Wis. Adm. Code shall be punishable as prescribed in chapter 110.075 (7), Wis. Stats.

History: Cr. Register, March, 1974, No. 219, eff. 4-1-74.

MVD 5.07 Severability. Should any section, paragraph, phrase, sentence, or clause of this chapter be declared invalid or unconstitutional, the remainder of this chapter shall not be affected thereby.

History: Cr. Register, March, 1974, No. 219, eff. 4-1-74.

MVD 5.08 Definitions. Words and phrases defined in section 340.01 Wis. Stats. are used in the same sense in this chapter unless a different definition is specified.

(1) "AUXILIARY LAMP" means any lamp mounted on a vehicle in addition to the lamps required under chapter 347.

(2) "BACK-UP LAMP" means any lamp designed to provide road illumination to the rear of a vehicle when the vehicle is in reverse gear.

(3) "BUMPER" means a device mounted at the front and rear of a vehicle for absorbing shock or preventing damage.

(4) "DUAL BEAM HEADLAMP" means a headlamp designed to provide more than one fixed beam by use of more than one lamp filament and such beams are changeable from the driver's seat.

(5) "EXHAUST SYSTEM" means all components used on a motor vehicle for discharging exhaust fumes starting at the engine exhaust ports. The exhaust system shall include the manifold, heat riser insert, exhaust pipe, muffler, resonator, tailpipe, and gas recirculation system.

(6) "FENDER" means a guard or covering over the wheels of a vehicle to prevent the splashing of water, mud or other materials which may be thrown by the wheels.

(7) "FIREWALL" means that portion of the vehicle separating the passenger compartment from the engine compartment.

(8) "FLASHING WARNING LAMPS" means all direction signal lamps or 4 other lamps which flash simultaneously to warn motorists of a vehicular traffic hazard. This definition does not include the flashing red signals required on school buses.

(9) "FLOORPAN" means that portion of a vehicle separating the passenger and trunk compartments from the chassis of a vehicle.

(10) "FUEL SYSTEM" includes the fuel tank, cap, filler pipe, pump, carburetor, evaporative system and all accompanying piping.

(11) "HEAD RESTRAINT" means a device in a motor vehicle that limits the rearward motion of a person's head. Any head restraints may be part of the seat or attached to the seat.

(12) "HOMEMADE VEHICLE" means any vehicle which has been constructed or assembled from new or used parts, or both. A hand built vehicle will be referred to as a homemade vehicle.

(13) "HORN" means a warning device which produces audible sound, mounted on a vehicle.

(14) "LASH" means the condition in which the steering wheel may be turned through some part of a revolution without associated movement of the front wheels.

(15) "MANUFACTURED VEHICLE" means a vehicle assembled or constructed by a manufacturer as defined in section 340.01 (28) Wis. Stats.

(16) "NON-TRANSPARENT MATERIALS" means all materials including those that may be sprayed or painted on the glazing surface of a vehicle which restricts the clear view of any object or person.

(17) "PARKING LAMPS" means 2 lamps mounted on the front of a motor vehicle, one on each side, designated to mark the front of the vehicle when parked.

(18) "RECONSTRUCTED VEHICLE" means a vehicle where some major portion of the vehicle (chassis or body) has been altered or reassembled from the manufacturers original specification. Such alterations or assembly may or may not change the appearance of the vehicle. Examples: Change of drive train or frame or major portion of suspension system or major portion of the body. A reconstructed vehicle may include one or more of these examples. A vehicle would not qualify for reconstructed status by the mere changing of an engine or wheels and tire size or springs or any other minor replacement item. These are only examples and are not all inclusive.

(19) "REGISTRATION PLATE LAMP" means a lamp designed to illuminate the rear registration plate of a vehicle.

(20) "RESTRAINING DEVICE" means any device used to contain persons in the seat of a motor vehicle in the event of collision or other cause.

(21) "SEALED BEAM UNIT." (a) 7-Inch Type 2 Sealed Beam Unit: (Passenger and commercial vehicles only.) A sealed unit 7 inches in diameter providing an upper and a lower beam. Two similar units are used on a vehicle. This unit is identified by a number "2" on the lens and is aimed on the lower beam.

(b) 7-Inch Sealed Beam Unit—No Identifying Number on Lens: (Passenger and commercial vehicles only.) A sealed unit 7 inches in diameter providing an upper and lower beam. Two similar units are used on a vehicle. This is an obsolete unit no longer being installed in production. It should be aimed on the upper beam.

(c) 5¾ Inch Type 1 Four-Lamp Dual Sealed Beam Unit: A sealed unit 5¾ inches in diameter having a single filament and providing only an upper beam distribution of light.

(d) 5¾ Inch Type 2 Four-Lamp Dual Sealed Beam Unit: A sealed unit 5¾ inches in diameter having 2 filaments—one filament providing the lower beam and one filament providing fill-in light for the upper beam. It is aimed on the lower beam.

(22) "SHOCK ABSORBERS" means an energy dissipating device on a vehicle which increases vehicle stability and improves steering, handling and ride performance.

(23) "SINGLE BEAM HEADLAMP" means a headlamp designed to provide one fixed beam which is not adjustable from the driver's seat.

(24) "STEERING WHEEL" means a device in the shape of a circle mounted on the steering shaft in the driver's compartment of a motor vehicle, other than a motor driven cycle, for use by the driver to maneuver the steering system of a motor vehicle.

(25) "SUSPENSION SYSTEM" means that portion of a vehicle between the frame and the axles including but not limited to springs, torsion bars, shackles, shock absorbers, cross stabilization bars, anti-sway bars and all attachment parts.

(26) "TIRES AND RIMS" (see diagram No. 2). (a) Rim. Metal support for tire or tire and tube assembly on the wheel. Tire beads are seated on the rim.

(b) **Bead.** That part of the tire which is shaped to fit the rim. Made of high-tensile steel wires wrapped and reinforced by the plies.

(c) **Sidewall.** That portion of the tire between tread and bead.

(d) **Cord.** Textile, steel wire strands, and the like, forming the plies or other structure of the tires.

(e) **Ply.** Layer of rubber-coated parallel cords forming the tire body.

(f) **Tread.** That portion of the tire that comes in contact with the road.

(g) **Rib.** The tread section running circumferentially around the tire.

(h) **Groove.** Space between 2 tread ribs.

(i) **Belt.** Layer or layers made of fabric or other material located under the tread area.

(27) "VEHICLE EMISSION CONTROL DEVICE" means the device on a motor vehicle designed to effectively reduce exhaust emissions from the engine.

(28) "WINDSHIELD" means the transparent shield of safety glass mounted forward of the passenger compartment of a motor vehicle other than a motor driven cycle.

History: Cr. Register, March, 1974, No. 219, eff. 4-1-74.

Subchapter I STEERING—SUSPENSION

MVD 5.12 Steering and suspension. (1) The steering and suspension of every motor vehicle shall be maintained in proper working condition and in conformity with this section. The steering linkage shall not be worn or jammed nor shall the steering system have excessive lash. The belts assisting the power steering unit shall be in proper working condition. Every motor vehicle originally equipped with a steering wheel shall have a steering wheel of the same size in proper working condition. The steering wheel shall be secured to the steering shaft by a locking device in the same manner as originally installed. Every motor driven cycle shall be equipped with handlebars meeting the requirements of section 347.486 of the Wis. Stats. Any motor driven cycle with a modified front suspension system so modified before January 1, 1976 shall have a rake of no more than 55° nor a trail of less than 2 inches. Any motor driven cycle commencing with the 1976 models shall not be modified in any way to cause the front suspension system to have a rake of more than 50° nor a trail of less than 2 inches. The springs, shackles, and cross stabilization linkage including torsion bars shall be in proper adjustment and not be loose, disconnected or broken. No alterations or modifications may be made to the suspension system, axles or chassis that would cause any portion of the vehicle except motor driven cycles to ride higher or lower by more than 2 inches from that specified by the manufacturer when measured from the level surface upon which the vehicle stands. Such alterations purpose shall be to strengthen the suspension system. Use of extended shackles shall be an

Register, January, 1976, No. 241

unsafe modification. Every vehicle except motor driven cycles originally equipped with shock absorbers shall have shock absorbers in all places as originally equipped. A motor driven cycle shall be equipped with a shock absorbing front suspension system. The main tubes or sliding tubes on a telescoping front suspension system shall be of one piece construction. Screw on extensions (slugs) shall not be used. All shock absorbers shall be in proper working order and free of leaks. It shall be unlawful for any vehicle to be operated on a highway if:

(a) The steering is loose or is binding at any point of the turning cycle. The lash is in excess of $\frac{1}{8}$ of one complete turn of the steering wheel. The steering linkage has broken, disconnected, or noticeably loose parts.

(b) The shock absorbing units are ineffective, leaking, or improperly modified.

(c) The vehicle is noticeably out of alignment.

(d) The springs or shackles are broken or extended shackles are used.

(e) Any modification has been made to any part of the suspension system, axle, or chassis except on motor driven cycles which would cause any portion of the vehicle to ride higher or lower by more than 2 inches from that specified by the manufacturer when measured from the level surface upon which the vehicle stands.

(f) The belts assisting the power steering unit are loose, frayed or cracked or any portion of the power steering mechanism is disconnected.

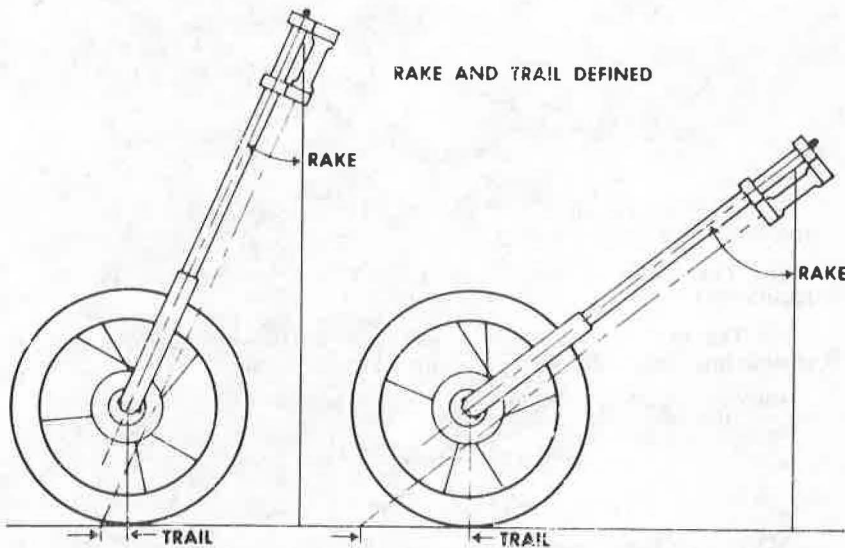

Figure 1

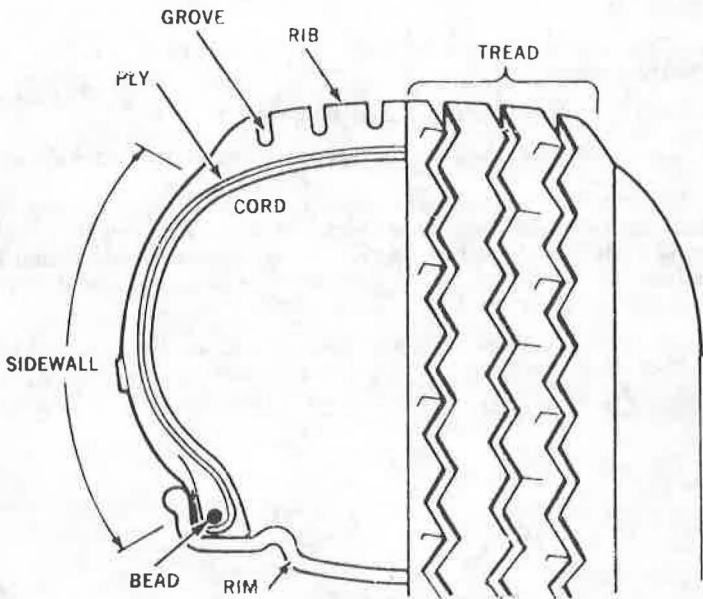
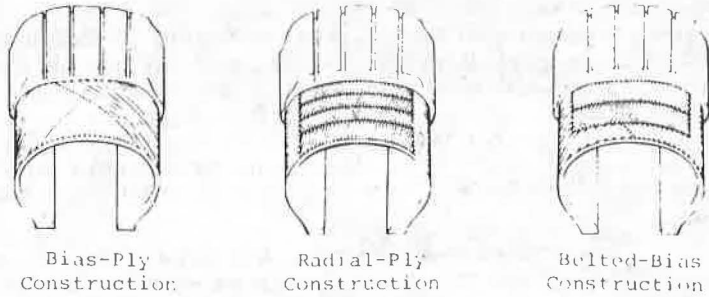

Figure 2

(g) The vehicle does not have a proper steering wheel or the steering wheel is not securely fastened as required by this subchapter.

(h) The vehicle is a motor driven cycle and does not have proper handlebars.

(i) The vehicle is a motor driven cycle and the front suspension system has been modified with an illegal rake or trail.

History: Cr. Register, March, 1974, No. 219, eff. 4-1-74; am. Register, January, 1976, No. 241, eff. 2-1-76.

Subchapter II

TIRES, WHEELS AND RIMS

MVD 5.14 Tire, wheel and rim. (1) The tires, wheels and rims on every motor vehicle, trailer, semi-trailer, and mobile home shall be maintained in proper condition and in conformity with this section.

Register, January, 1976, No. 241

Every tire shall have no less than 2/32 inch tread depth. The depth shall be measured at 2 points no less than 15 inches apart in any major tread groove at or near the center of the tire. All tires on vehicles with an empty weight of less than 6000 pounds shall be of such size so as not to protrude, by more than 2 inches, beyond the manufacturer's original body or fender line at the highest point of the tire. All tires shall be adequately covered to comply with section 5.63 Wis. Adm. Code. Any combination of suspension change or tire or wheel size change shall raise or lower the vehicle except motor driven cycles no more than 2 inches from that specified by the manufacturer when measured from the level surface upon which the vehicle stands. It shall be unlawful for any vehicle to be operated on a highway if:

- (a) The tire has been repaired by use of a blow-out patch or boot.
- (b) There are tread cuts or snags in excess of one inch in any direction as measured on the tire which are deep enough to expose or damage the body cords or there is a bump, bulge, knot, sidewall separation or failure or partial failure of the tire structure.
- (c) The tire has been stamped or marked "For off highway use," "For farm use only," "Not for street use," "For racing only," or which is stamped or marked in any other manner so as to indicate that such tire is not to be operated on a highway.
- (d) The tire is worn to the point where part of the ply or cord construction is exposed or there is less than 2/32 inch tread depth measured at 2 points no less than 15 inches apart in any major tread groove at or near the center of the tire.
- (e) The tire has been regrooved or recut and is being used on a passenger car or motor driven cycle, except tires that are specifically designed for commercial vehicles and manufactured in such a manner than regrooving or recutting is an acceptable and safe practice. See section 347.45 (4) Wis. Stats. regarding tire equipment.
- (f) The studded tires are on the vehicle during the period when use is prohibited.
- (g) The wheels or rims are damaged so that continued use may be hazardous.
- (h) The vehicle has loose or missing wheel nuts, lugs or bolts.
- (i) The vehicles empty weight is less than 6000 pounds and is equipped with tire(s) of such size that it protrudes by more than 2 inches beyond the manufacturer's original body or fender line at the highest point of the tire or any combination of suspension change or tire or wheel size change that shall raise or lower the vehicle except motor driven vehicles more than 2 inches from that specified by the manufacturer when measured from the level surface upon which the vehicle stands.

History: Cr. Register, March, 1974, No. 219, eff. 4-1-74; am. Register, January, 1976, No. 241, eff. 2-1-76.

Subchapter III BRAKES

MVD 5.22 Brakes. (1) The brake system on every motor vehicle shall be maintained in proper working condition and in conformity with this section except that a motor driven cycle need only have one brake meeting the requirement of section 347.35(2) Wis. Stats. The vehicle shall have no noticeable side pull when the brakes are applied. Brake pedals shall have no less than 20% of total pedal travel left when fully depressed. The brake systems shall be connected and free of leaks. It shall be unlawful to operate any vehicle upon a highway if:

- (a) The vehicle stops with obvious side pull.
- (b) There is insufficient pedal reserve or the pedal fades under pressure.
- (c) The cables are frayed or hoses are abraded.
- (d) There is excessive grease, oil, or fluid on the wheel that may have contaminated the braking surface.
- (e) Any portion of the total braking mechanism is disconnected or any portion of the system leaks except that a motor driven cycle need only comply with the requirements of section 347.35(2) Wis. Stats.
- (f) The parking brake mechanism has no reserve, or fails to hold vehicle under load test, or the mechanism does not release under normal conditions.

History: Cr. Register, March, 1974, No. 219, eff. 4-1-74; am. Register, January, 1976, No. 241, eff. 2-1-76.

Subchapter IV EXHAUST AND FUEL SYSTEMS

MVD 5.24 Exhaust and fuel systems. (1) The exhaust and fuel systems on every motor vehicle shall be maintained in proper working order and in conformity with this section. All vehicle emission control devices originally installed by the manufacturer or comparable tested replacement devices shall remain installed and in proper working order. Piping used in exhaust systems shall be of the rigid type. Flexible tubing shall not be acceptable for use in the exhaust system except in its use in motor driven cycles, road tractors, truck tractors, or trucks over 10,000 pounds GVW, where the connection is outside the cab line. Every exhaust system, so located as to be hazardous to a person outside the vehicle or to a person entering or leaving a vehicle shall have a protective shield to prevent such person from being burned or injured. Every motor driven cycle must have a protective shield only if the exhaust system is above and to the rear of the foot pegs and if such vehicle was originally equipped with a protective shield over the exhaust system or parts thereof. It shall be unlawful for any vehicle to be operated on the highway if:

- (a) The muffler or any part of the exhaust system has been repaired by an inadequate patch, is not adequate for discharging fumes, or non-rigid type tubing is used except in the case of motor driven cycles, road tractors, truck tractors or trucks over 10,000 pounds GVW where the connection is outside the cab line.

Register, January, 1976, No. 241

(b) The tail pipe does not extend to the outside body line of the vehicle or manufacturers standard except that motor trucks or road tractors or truck tractors shall have the exhaust outlet extend to the rear of the vehicle cab.

(c) There is excessive noise, indicating an illegal, worn out, or modified muffler.

(d) The exhaust system is modified to pass through the passenger compartment.

(e) The fuel system inspection discloses leakage.

(f) The fuel cap is missing or the fuel tank is not rigidly attached to the vehicle or there is any fuel tank in the passenger compartment other than that installed by the manufacturer or there is a homemade fuel tank in the engine compartment or trunk of the vehicle.

(g) The vehicle emission control system or any part thereof when installed as original equipment or comparable tested replacement devices has been removed or disconnected.

(h) Any part of the exhaust system is exposed where it is hazardous to a person outside the vehicle and does not have a protective shield or if a motor driven cycle and the exhaust system has no protective shield on that portion of the system above and to the rear of the foot pegs and the motor driven cycle was originally equipped with a protective shield over the exhaust system or parts thereof.

History: Cr. Register, March, 1974, No. 219, eff. 4-1-74; am. Register, January, 1976, No. 241, eff. 2-1-76.

Subchapter V

LIGHTING—ELECTRICAL

MVD 5.26 Headlamps. (1) The headlamp system on every motor vehicle shall be maintained in proper working order and in conformity with this section. Every motor vehicle manufactured commencing with the 1950 models, except motor driven cycles, shall be equipped with either a single headlamp system using two 7 inch sealed beam units or a dual headlamp system using two 5¼ inch Type I and two 5¼ inch Type II sealed beam units. The sealed beam units must meet requirements for Sealed Beam Headlamp Units for Motor Vehicles—SAE J 579a (published in the 1972 SAE Handbook). This standard is obtainable from the Society of Automotive Engineers, 485 Lexington Avenue, New York, N.Y. 10017. This reference is also available in the office of the division of motor vehicles, the revisor of statutes, and the secretary of state. Every other motor vehicle equipped with headlamps shall have the same number, type and size of headlamps as originally manufactured or may be equipped as set forth above. Every motor vehicle except motor driven cycles, shall have an equal number of headlamps on each side of the vehicle installed at least 12 inches from the center of the vehicle. Every headlamp shall be properly installed and securely fastened. The headlamp mounting shall be in good condition. No headlamp shall have any type of cover that in any way restricts the amount of light emitted. The headlamp switch, dimmer switch and beam indicator shall be in proper working condition. All wiring and connections shall be in good condition. Every headlamp shall be properly aimed in

accordance with section MVD 5.27 Wis. Adm. Code. It shall be unlawful for any vehicle to be operated on a highway if:

- (a) Any headlamp does not function.
- (b) The headlamp switch does not function properly.
- (c) Any headlamp is broken or missing.
- (d) Any headlamp is mounted improperly or the headlamp mounting is loose.
- (e) There are inadequate or illegal headlamps.
- (f) The headlamp beam indicator does not function properly.
- (g) The dimmer switch does not function properly.
- (h) The connections or wiring are in poor condition.
- (i) The headlamp aim is improper.

History: Cr. Register, March, 1974, No. 219, eff. 4-1-74.

MVD 5.27 Headlight inspection equipment and procedure. (1) **AIM INSPECTION EQUIPMENT.** It is recommended that mechanically aimable headlamps be aimed and inspected for aim by mechanical aimers. Another aiming and inspection method is by visual means on a screen at a distance of 25 feet ahead of the headlamps or on the screen of a headlamp testing machine. Photo electric aiming and inspection is not acceptable. Beams shall be inspected for aim by one of the following methods:

(a) **Mechanical Aimers:** If a mechanical aimer is used, it shall conform to the requirements of SAE Recommended Practice, Headlamp Aiming Device for Mechanically Aimable Sealed Beam Headlamp Units—SAE J602a (published in the 1972 SAE Handbook). The device shall be in good repair and adjustment and shall be used according to the manufacturer's instructions. Mechanical aimers shall be used only on mechanically aimable sealed beam units. This standard is obtainable from the Society of Automotive Engineers, 485 Lexington Avenue, New York, N.Y. 10017. This reference is also available in the Office of the division of motor vehicles, the revisor of statutes, and the secretary of state.

(b) **Screen:** If a screen is used, it shall conform to the requirements of SAE Lighting Inspection Code SAE J 599b. This standard is obtainable from the Society of Automotive Engineers, 485 Lexington Avenue, New York, N.Y. 10017. This reference is also available in the office of the division of motor vehicles, the revisor of statutes, and the secretary of state.

(c) **Headlamp Testing Machines:** If a headlamp testing machine is used, it shall conform to the requirements of SAE Recommended Practice, Headlamp Testing Machines—SAE J600a (published in the 1972 SAE Handbook). It shall be in good repair and adjustment and shall be used in accordance with the manufacturer's instructions. This standard is obtainable from the Society of Automotive Engineers, 485 Lexington Avenue, New York, N.Y. 10017. This reference is also available in the office of the division of motor vehicles, the revisor of statutes, and the secretary of state.

(2) **PREPARATION FOR AIMING.** Prior to testing headlights, the vehicle shall be located in an approved space having a level floor and in proper alignment with the screen or tester. Before checking beam aim, the inspector shall:

- (a) Remove ice or mud from under fenders;
- (b) See that all tires are properly inflated;
- (c) Rock the vehicle sideways;
- (d) Check springs for sag or broken leaves;
- (e) Take into consideration faulty wheel adjustment or improper tracking of the rear axle;
- (f) See that there is no unusual load in the vehicle other than the driver in the front seat;
- (g) Check functioning of any "level-ride" control;
- (h) Clean lenses; check for broken or cracked aiming pads; bulb burn-out and proper beam switching;
- (i) See that light output is well toward the normal new lamp value.

(3) **AIM LIMITS.** (a) *Mechanical Aimers*

1. All sealed beams shall be aimed horizontally no more than 4 inches to the left or right of straight ahead.
2. All sealed beams shall be aimed vertically no more than 4 inches above or below of lamp center level.
3. The correct setting when adjusting headlamps shall be 0 left, 0 right, 0 up and 0 down.

(b) *Visual Method*

1. Type I units shall have the center of the high intensity zone no more than 4 inches up or 4 inches down, nor more than 4 inches left or 4 inches right on a screen at 25 feet.
2. Type 2 units shall have the top edge of the high intensity zone no more than 4 inches up or 4 inches down and the left edge of the high intensity zone no more than 4 inches left or 4 inches right on a screen at 25 feet.

History: Cr. Register, March, 1974, No. 219, eff. 4-1-74.

MVD 5.28 Parking lamps. (1) The parking lamps and lens of every motor vehicle shall be maintained in proper working condition and in conformity with this section. Every motor vehicle manufactured commencing with the 1950 models, except motor driven cycles, shall be equipped with two lamps visible from the front and meeting the visibility requirements as set forth in sections 347.27 (1) (b) 1 and 2 Wis. Stats. Tail lamps shall be so wired as to be lighted whenever the parking lamps are lighted. All wiring and connections shall be maintained in good condition. It shall be unlawful for any vehicle to be operated if:

- (a) Any parking lamp does not function.
- (b) The parking lamp switch does not function properly.

(c) Any parking lamp is missing or if there is a broken or cracked lens or reflector.

(d) The parking lamp wiring or connections are in poor condition.

History: Cr. Register, March, 1974, No. 219, eff. 4-1-74.

MVD 5.29 Front direction signal lamps. (1) The front direction signal lamp system of every motor vehicle so originally equipped shall be maintained in proper working condition and in conformity with this section. All self-cancelling direction signal switches shall be in proper working order. The direction signal indicator lamps shall be in proper working order. All wiring and connections shall be maintained in good condition. It shall be unlawful for any vehicle to be operated on a highway if:

(a) Any front direction signal lamp does not function.

(b) The direction signal switch does not function properly.

(c) The signal indicator lamp fails to function.

(d) There is a cracked, broken or missing lens or reflector.

(e) The vehicle is not equipped as required by law.

(f) The front direction signal lamp wiring or connections are in poor condition.

History: Cr. Register, March, 1974, No. 219, eff. 4-1-74.

MVD 5.30 Tail lamps. (1) The tail lamps of every vehicle shall be maintained in proper working condition and in conformity with this section. The tail lamps shall be so wired as to be lighted whenever the parking lamp or headlamps are lighted. All wiring and connections shall be maintained in good condition. The tail lamp lens and reflector shall be installed and maintained in proper working condition. It shall be unlawful for any vehicle to be operated on a highway if:

(a) Any tail lamp does not function properly.

(b) The tail lamp switch does not function properly.

(c) Any tail lamp or lens is broken or missing or the lens is not of the reflective type.

(d) The reflector is missing or improperly mounted.

(e) There are inadequate or illegal tail lamps or reflectors.

(f) The tail lamp wiring or connections are in poor condition.

History: Cr. Register, March, 1974, No. 219, eff. 4-1-74.

MVD 5.31 Stop lamps. (1) The stop lamps of every vehicle shall be maintained in proper working condition and in conformity with this section. Every motor vehicle manufactured commencing with the 1950 models, except motor driven cycles, shall be equipped with at least 2 stop lamps. All wiring and connections shall be maintained in good condition. The stop lamp lens shall be installed and maintained in proper condition. It shall be unlawful for any vehicle to be operated on a highway if:

Register, January, 1976, No. 241

- (a) Any stop lamp does not function properly.
- (b) Any stop lamp or lens is broken or missing.
- (c) There are inadequate or illegal stop lamps.
- (d) The stop lamp wiring or connections are in poor condition.

History: Cr. Register, March, 1974, No. 219, eff. 4-1-74.

MVD 5.32 Rear direction signal lamps. (1) The rear direction signal lamp system of every vehicle so originally equipped shall be maintained in proper working condition and in conformity with this section. All self-cancelling direction signal switches shall be in proper working order. The direction signal indicator lamps shall be in proper working order. All wiring and connections shall be maintained in good condition. It shall be unlawful for any vehicle to be operated on a highway if:

- (a) Any rear direction signal lamp does not function.
- (b) The direction signal switch does not function properly.
- (c) The signal indicator lamp fails to function.
- (d) Any rear direction lamp lens or reflector is broken or missing.
- (d) The vehicle is not equipped as required by law.
- (f) The rear direction signal lamp wiring connections are in poor condition.

History: Cr. Register, March, 1974, No. 219, eff. 4-1-74.

MVD 5.33 Registration plate lamp. (1) All registration plate lamps shall be maintained in proper working condition and in conformity with this section and section 347.13 (3) and (4) of the Wis. Stats. The registration plate lamp shall be so constructed so as to prevent a white beam of light directed to the rear of the vehicle. The registration plate lamp wiring and connections shall be maintained in good condition. It shall be unlawful for any vehicle to be operated on a highway if:

- (a) The registration plate lamp fails to function properly.
- (b) There is an inadequate or illegal registration plate lamp.
- (c) The registration plate lamp wiring or connections are in poor condition.

History: Cr. Register, March, 1974, No. 219, eff. 4-1-74.

MVD 5.34 Back up lamp. (1) The back up lamps on those vehicles originally equipped with back up lamps shall be maintained in proper working condition and in conformity with this section and section 347.26 (4) of the Wis. Stats. The back up lamp wiring and connections shall be maintained in good condition. Back up lamps shall be incorporated with a switch on the transmission system so the lamps are lighted only when the transmission is in reverse gear, or may be manually turned on by a switch in the driver's compartment providing there is also an indicator light plainly visible to the vehicle driver indicating when the back up lamps are on. It shall be unlawful for any motor vehicle to be operated on a highway if:

Register, January, 1976, No. 241

- (a) The back up lamps fail to function.
- (b) The back up lamps remain lighted when the vehicle is not in reverse gear.
- (c) The back up lamp wiring or connections are in poor condition.
- (d) The motor vehicle is equipped with a manual back up lamp switch and does not have an indicator light in operating condition.

History: Cr. Register, March, 1974, No. 219, eff. 4-1-74.

MVD 5.35 Horn. (1) The horn of every motor vehicle shall be maintained in proper working condition and in conformity with this section. The horn wiring and connections shall be maintained in good condition. The horn shall be securely fastened to the vehicle. The vehicle shall be equipped with a button or ring for making electrical connection. Any vehicle other than an authorized emergency vehicle shall not be equipped with a siren or exhaust whistle. It shall be unlawful for any motor vehicle to be operated on a highway if:

- (a) The vehicle is not equipped with a horn.
- (b) The horn is not securely fastened to the vehicle.
- (c) The horn fails to function or is not audible for 200 feet.
- (d) The vehicle is not equipped with a button or ring for making electrical connection.
- (e) The vehicle is equipped with an unlawful siren or exhaust whistle.
- (f) The horn wiring or connections are in poor condition.

History: Cr. Register, March, 1974, No. 219, eff. 4-1-74.

MVD 5.36 Auxiliary lamps. (1) In this section auxiliary lamp shall include auxiliary driving lamps, adverse weather lamps and spot lamps. Any vehicle equipped with auxiliary lamps shall have such lamps maintained in proper working condition. No vehicle shall be equipped with an auxiliary lamp having a candle power intensity of more than 75,000 candle power when measured at the lens. Auxiliary driving lamps and adverse weather lamps shall be mounted below the level of the center of the headlamps but no lower than 15 inches above the ground on which the vehicle stands. Adverse weather lamps used in lieu of headlamps shall be mounted at least 12 inches from the center of the vehicle and at the same plane. The adverse weather lamp and auxiliary driving lamp wiring and connections shall be in good condition. Auxiliary driving lamps and adverse weather lamps shall be aimed in accordance with MVD 5.27 (3) (b) Wis. Adm. Code. It shall be unlawful for a vehicle to be operated on a highway if:

- (a) Any auxiliary lamp fails to function.
- (b) Any auxiliary lamp is improperly mounted.
- (c) There are any illegal auxiliary lamps.
- (d) The auxiliary lamp wiring or connections are in poor condition.
- (e) Any auxiliary lamp is improperly aimed.

History: Cr. Register, March, 1974, No. 219, eff. 4-1-74.

Register, January, 1976, No. 241

MVD 5.37 Sidemarker lamps and reflectors. (1) Any vehicle originally equipped with sidemarker lamps or reflectors shall have such lamps or reflectors maintained in proper working condition and in conformity with this section. The sidemarker lamp wiring and connections shall be maintained in good condition. Every passenger vehicle manufactured after January 1, 1969, or assembled after January 1, 1975 shall be equipped with sidemarker lamps or reflectors. Every vehicle having a width at any part in excess of 80 inches shall comply with those provisions provided in section 347.16 of the Wis. Stats. It shall be unlawful for any vehicle to be operated on a highway if:

(a) The vehicle is not equipped with required sidemarker lamps and reflectors.

(b) Any sidemarker lamp or reflector is not securely mounted or is inadequate.

(c) Any sidemarker lamp wiring or connections are in poor condition.

History: Cr. Register, March, 1974, No. 219, eff. 4-1-74.

MVD 5.38 Flashing warning lamps. (1) Any vehicle originally equipped with flashing warning lamps shall maintain such lamps in proper working condition and in conformity with this section. The flashing warning lamp wiring and connections shall be maintained in good condition. Every vehicle except motor driven cycles, manufactured after January 1, 1969, or assembled after January 1, 1975 shall be equipped with flashing warning lamps. It shall be unlawful for any vehicle to be operated on a highway if:

(a) The vehicle is not equipped with required flashing warning lamps or the lamps fail to function.

(b) The flashing warning lamp is not securely mounted or is inadequate.

(d) Any flashing warning lamp wiring or connections are in poor condition.

NOTE: See section 347.26 (11) (a) of Wis. Stats. regarding flashing warning lamps

History: Cr. Register, March, 1974, No. 219, eff. 4-1-74.

MVD 5.40 Windshield defroster—defogger. (1) Every motor vehicle ordinarily equipped with a windshield defroster—defogger and manufactured after January 1, 1955, except motor driven cycles, shall be equipped with a defroster—defogger system. The defroster—defogger system shall be capable of adequately keeping the moisture or frost off the windshield. The defroster-defogger fan, switch and wiring shall be maintained in good working condition. It shall be unlawful for any motor vehicle to be operated upon a highway if:

(a) The defroster—defogger fails to function or the vehicle is not equipped when required.

(b) The defroster—defogger is not capable of supplying enough air to clear the moisture or frost off the windshield.

History: Cr. Register, March, 1974, No. 219, eff. 4-1-74.

Subchapter VI GLAZING

MVD 5.51 Windshields. (1) Every motor vehicle manufactured after January 1, 1936 except motor driven cycles, shall have a windshield made of safety glass. Every windshield shall be plainly marked as to identify it as safety glass. The windshield shall be of such size to provide adequate protection for the driver. The windshield shall not have cracks in excess of 4 inches from the frame on flat and curved glass or 8 inches on wrap around glass on the driver's side, nor shall a crack extend into the critical area. The passenger side of the windshield shall not have cracks in excess of 11 inches from the outer right hand edge on flat and curved glass and 12 inches from the edge on wrap around glass. The windshield shall not have stone or shot damage with a diameter in excess of 1/2 inch in the critical wiper blade area or in excess of 1 1/2 inches in any other area. The windshield shall not have scratches of any type which may distort vision. The windshield shall not have cloudiness in excess of one inch around the outside edge on the driver's side or in excess of 2 inches on the passenger's side. There shall not be any poster, stickers or other nontransparent materials except those allowed by law located on the windshield or located between the driver and the windshield. It shall be unlawful to operate a motor vehicle on a highway if:

(a) The vehicle is not equipped with a windshield or there is no approved safety glass.

(b) The windshield has more than one inch of cloudiness around the outside edge on the driver's side or 2 inches on the passenger side.

(c) The windshield has cracks showing sharp edges or scratches severe enough to distort vision.

(d) The windshield has excessive cracks or damage.

(e) The windshield has unlawful nontransparent material on it or there is nontransparent material located between the driver and the windshield or the windshield is tinted by any means other than that used in the original manufacturing process.

History: Cr. Register, March, 1974, No. 219, eff. 4-1-74.

GLAZING DIAGRAM

Looking into car

Driver's side

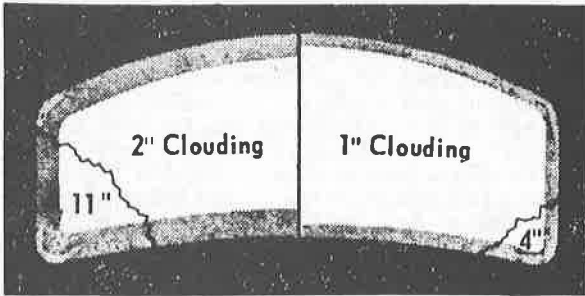

Flat or Curved Windshield

Looking into car

Driver's side

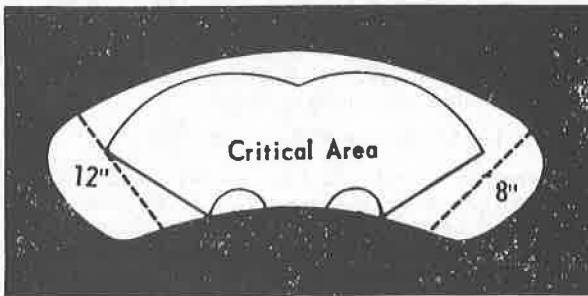

Wrap-Around Windshield

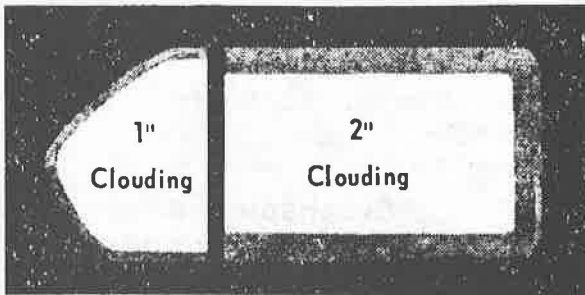

Vent

Side

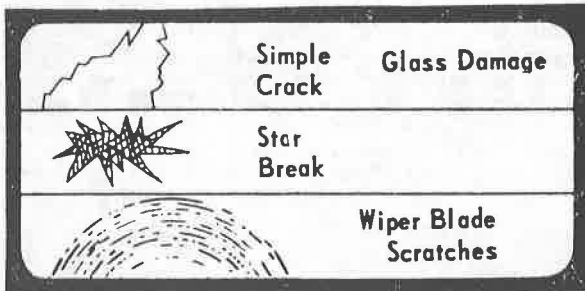

MVD 5.52 Vent, side and rear windows. (1) Any motor vehicle originally equipped with glazing material in the vent, or front side windows shall have all such material installed. All glass used in vent, side or rear windows shall be approved safety glass, and shall be plainly marked as safety glass. There shall be no cracks or other damage to the vent, side or rear windows which distort vision or have sharp edges severe enough to cause injury. The vent window shall not have in excess of one inch of cloudiness around any edge and the front side windows shall not have in excess of 2 inches of cloudiness on any edge. The front side window at the driver's left must operate so as to permit arm signals to be made. The rear window shall not have more than 2 inches of cloudiness from any edge unless the vehicle is equipped with an outside rear view mirror on the driver's side. There shall be no posters, stickers or other nontransparent materials, except those allowed by law, located on the vent or side windows to the immediate right and left of the driver or rear windows. No object shall be placed or suspended in or upon the vehicle so as to obstruct the driver's clear vision through the vents or front side windows. No object shall be placed or suspended in or upon the vehicle so as to obstruct the driver's clear vision through the rear window unless such vehicle is equipped with an outside rear view mirror meeting the requirements of section 347.30 Wis. Stats. It shall be unlawful for any vehicle to be operated on a highway if:

- (a) The window at the driver's left is not operable.
- (b) The vent, front side windows or rear windows have unlawful nontransparent material on them or there are nontransparent materials located between the driver and the front side windows or these windows have been tinted by any means other than that used in the original manufacturing process.
- (c) There is unlawful cloudiness cracks or damage on the vent, front side or rear side windows.
- (d) If the driver's view through the rear window is obstructed and the vehicle is not equipped with an outside rear view mirror on the driver's side.
- (e) The glass of any vent side window or rear window is not approved safety glass.

History: Cr. Register, March, 1974, No. 219, eff. 4-1-74.

Subchapter VII

WINDSHIELD WIPERS, MIRRORS, AND SPEED INDICATOR

MVD 5.54 Windshield wipers. (1) The windshield wiper system of every motor vehicle shall be maintained in good working condition and in conformity with this section. All vehicles originally equipped with 2 wiper arms and 2 wiper blades (one set on the driver's side and one set on the passenger side) must have both in place. Every automobile manufactured after January 1, 1950 or assembled after January 1, 1975 shall have at least 2 windshield wipers—or a windshield wiper that meets the wiping requirements of FMVSS 104. This standard is obtainable from the National Highway Traffic Safety Administration, Nassif Bldg., 400 — 7th St., S.W., Washington, D.C.

Register, January, 1976, No. 241

20590. This reference is also available in the office of the division of motor vehicles, the revisor of statutes, and the secretary of state. Every windshield wiper shall be as large as practicable to adequately clear the windshield. The windshield wiper switch, wiring or connections shall be in proper working condition. Every vehicle originally equipped with a windshield washer system shall have it installed and maintained in operating condition with adequate fluid available when the mechanism is activated. It shall be unlawful for any vehicle to be operated on a highway if:

(a) Any windshield wiper arm or blade is missing or fails to function by the use of either an electric motor, or hydraulic or vacuum device.

(b) Any windshield wiper blade is not in good condition.

(c) Any windshield wiper does not adequately clear the windshield.

(d) Any windshield wiper switch, wiring or connections are in poor condition.

(e) The windshield washer system is removed or is not in functioning condition.

History: Cr. Register, March, 1974, No. 219, eff. 4-1-74; am. Register, January, 1976, No. 241, eff. 2-1-76.

MVD 5.56 Mirrors. (1) The mirrors of every motor vehicle shall be maintained in proper working condition and in conformity with this section. Every motor vehicle shall be equipped with at least one mirror providing a clear view of the highway for a distance of 200 feet to the rear of the vehicle. No mirrors shall be cracked or discolored. All motor vehicles manufactured or assembled after January 1, 1975 shall be equipped with an outside left hand rear view mirror. If the vehicle is so constructed or loaded, or towing another vehicle so as to prevent the operator's clear view to the rear, adequate outside mirrors shall be installed. All mirrors shall be securely mounted on the vehicle. It shall be unlawful for any vehicle to be operated on a highway if:

(a) Any mirror is missing, loosely mounted or offers unsafe interference with the driver's view.

(b) The mirror is broken, cracked or discolored.

(c) The mirror does not provide a clear view of 200 feet to the rear of the vehicle.

History: Cr. Register, March, 1974, No. 219, eff. 4-1-74.

MVD 5.58 Speed indicator and odometer. (1) The speed indicator of every motor vehicle shall be maintained in proper working condition and in conformity with this section. The vehicle shall be equipped with a lamp that clearly illuminates the speed indicator during the hours of darkness. Every speed indicator shall be mounted as to be clearly visible to the driver at all times. Every motor vehicle shall be equipped with a mileage odometer that with reasonable accuracy registers the miles accumulated. The odometer shall be maintained in proper working condition. It shall be unlawful for any vehicle to be operated on a highway if:

- (a) The vehicle is not equipped with a speed indicator and odometer.
- (b) The speed indicator and odometer is not in proper operating condition.
- (c) The speed indicator is not clearly visible to the driver or properly illuminated.

History: Cr. Register, March, 1974, No. 219, eff. 4-1-74.

Subchapter VIII

MISCELLANEOUS

MVD 5.61 Restraining devices and seats. (1) The restraining devices and seats of every motor vehicle shall be maintained in proper working condition and in conformity with this section. All safety belts shall be of the approved type in accordance with the Society of Automotive Engineers Standards for Motor Vehicle Seat Belt Assemblies (SAE-J4c). Every passenger car manufactured after January 1, 1969 or assembled after January 1, 1975 shall be equipped with head restraints. This standard is obtainable from the Society of Automotive Engineers, 485 Lexington Avenue, New York, N.Y. 10017. This reference is also available in the office of the division of motor vehicles, the revisor of statutes, and the secretary of state.

(2) The seat and seat mechanisms of every motor vehicle shall be in proper working condition. All restraining devices originally installed on a vehicle shall remain installed or may be replaced with similar type devices which meet the SAE specification (SAE-J4c). It shall be unlawful for any vehicle to be operated on a highway if:

- (a) The vehicle is not equipped with required restraining devices.
- (b) The restraining devices or installation is non-standard or does not meet the SAE specification, SAE-J4c.
- (c) The restraining device material is frayed, split, torn, or brittle.
- (d) The anchors for any restraining devices are loose.
- (e) The restraining device latch mechanism is loose or inoperative.
- (f) The seat is loose or the seat mechanism does not function properly.

History: Cr. Register, March, 1974, No. 219, eff. 4-1-74; am. Register, January, 1976, No. 241, eff. 2-1-76.

MVD 5.62 Floor pan. (1) The floor pan in the passenger compartment and the trunk of every motor vehicle shall be maintained in good condition and in conformity with this section. The firewall shall be maintained free of holes and any mechanisms, cables and wires shall be properly sealed to prevent entry of exhaust gases. The floor pan shall be free of rusted areas or holes which may allow entry of exhaust gases or would not adequately support vehicle occupants. It shall be unlawful for any vehicle to be operated on a highway if:

- (a) Any floor pan or firewall has holes or rusted out areas.

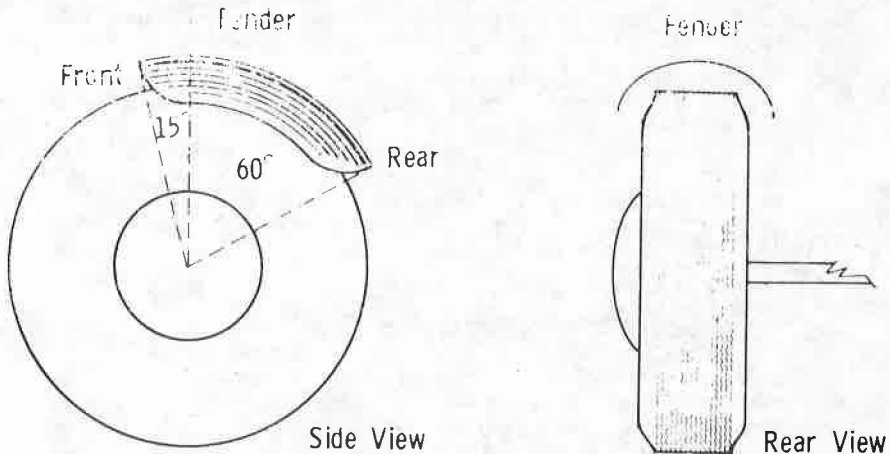

Figure 3

- (b) Any floor pan or firewall is not properly sealed.

History: Cr. Register, March, 1974, No. 219, eff. 4-1-74.

MVD 5.63 Bumper, fender and projecting parts. (1) The bumpers and fenders on every motor vehicle shall be maintained in good condition and in conformity with this section. Every passenger vehicle shall be equipped with adequate fenders covering the front and rear tires to prevent splashing of water and throwing gravel, stones or other objects. Every motor driven cycle shall have adequate fender covering the rear wheel(s). All fenders shall be free of severely rusted or damaged material which may cause injury or cause the fenders to be ineffective. All fenders shall be of sufficient width to completely cover the tire at its highest point. All fenders on passenger vehicles shall be of sufficient length to cover the tire from 15° to the front to 60° to the rear when measured at the center of the axle from a vertical plane. Every motor driven cycle shall have adequate fenders as provided by the manufacturer or in the absence of original equipment, a fender of a size not less than that provided by the manufacturer covering primarily the same area of the tire surface except that no fender is required to cover the front wheel. Every passenger vehicle except motor driven cycles, shall be equipped with an adequate bumper on the front and rear of the vehicle. Every passenger vehicle shall be equipped with the same type of bumper as originally equipped or a bumper equivalent in size, strength, and surface area. Bumpers shall be of sufficient strength to permit the fully loaded vehicle to be pushed without damage or distortion to the bumper. All bumpers shall be securely mounted to the vehicle. No bumper or fender shall be in such condition that may be hazardous to pedestrians or cyclists. No part of the vehicle or any vehicle accessory shall project away from the vehicle in a hazardous manner. It shall be unlawful for a vehicle to be operated if:

(a) Any required bumper or fender has been removed or the vehicle is not equipped with bumpers or fenders.

(b) Any bumper or fender is not securely mounted or is not adequate.

(c) Any bumper, fender or other part of the vehicle is damaged or distorted so that it projects away from the vehicle creating a hazard.

(d) Any fender on a passenger vehicle does not cover the tire lengthwise from 15 degrees to the front and 60 degrees to the rear when measured on a vertical plane at the center of the axle or if it does not completely cover the tire at the highest point of the tire to reasonably restrict objects or matter from being thrown about or if a motor driven cycle does not have a rear fender as provided by the manufacturer or a similar fender covering primarily the same area as that covered by the original equipment.

(e) The bumper is of a smaller size than originally equipped.

History: Cr. Register, March, 1974, No. 219, eff. 4-1-74; am. Register, January, 1976, No. 241, eff. 2-1-76.

MVD 5.65 Doors, locks and latches. (1) All latches, locks, hinges, and handles on every door, hood and trunk of every motor vehicle shall be maintained in proper working condition and in conformity with this section. Every motor vehicle except motor driven cycles and those vehicles manufactured with removable doors or without doors, shall be equipped with doors. No door shall be in any way secured by such objects as rope or wire. Every door on a vehicle shall open. The hood latch and safety catch shall operate properly. The hood shall have no protrusions that will restrict the drivers view of the road ahead. The trunk latch shall operate properly. It shall be unlawful for any vehicle to be operated on a highway if:

(a) The latches, locks, hinges or handles are damaged, worn or otherwise defective.

(b) A required door is missing or does not open properly.

(c) Any door, hood or trunk lid is secured by objects such as rope or wire except when transporting oversize objects.

(d) The hood has a protrusion that rises more than 3 inches above the hood line.

History: Cr. Register, March, 1974, No. 219, eff. 4-1-74.

Subchapter IX HOMEMADE, OR RECONSTRUCTED MOTOR VEHICLES

MVD 5.66 Homemade, or reconstructed motor vehicles. (1) Any homemade or reconstructed vehicle registered as a homemade or reconstructed vehicle before January 1, 1975 shall be exempt from the provisions of this section. To be exempt the vehicle must in fact be a homemade or reconstructed vehicle and be currently titled and registered for highway operation in Wisconsin. After January 1, 1975 every homemade or reconstructed motor vehicle shall comply with the standards set forth in this section and all other applicable vehicle equipment standards specified in this administrative rule and chapter 347 Wis. Stats. After January 1, 1975 reconstructed vehicles based upon body styles whose original manufacture was covered by Federal Motor Vehicle Equipment Standards shall continue to meet those standards from the year of original manufacture. After January 1,

Register, January, 1976, No. 241

1975 reconstructed vehicles based upon body styles whose original manufacture was not covered by federal motor vehicle standards shall not be required to update a reconstructed vehicle to current federal standards. Exempt would be the requirement to meet federal emission standards where the use of a pre-1968 engine in the reconstruction would make compliance with such standards impractical. Every homemade or reconstructed vehicle using a 1968 model year engine or later will be required to maintain all such emission control devices that were originally a part of the engine or be replaced by equipment providing equivalent emission control. Every homemade or reconstructed vehicle, upon completion of its assembly, shall be registered as being the current year manufactured vehicle. Every homemade or reconstructed vehicle, upon completion of its assembly, shall be inspected, prior to being registered, for compliance with this administrative rule and chapter 347 Wis. Stats. by an agent of the division of motor vehicles. Every such vehicle shall be equipped with a steering wheel at least 13" in diameter except a motor driven cycle which shall be equipped with handlebars meeting statutory requirements. Every homemade or reconstructed vehicle shall have braking ability on every wheel-except that motor driven cycles need only meet the statutory requirements of section 347.35(2), Wis. Stats. Every such vehicle except motor driven cycles shall be equipped with bumpers on the front and rear of the body. Each bumper shall extend to a width of 36 inches and the face of the bumper shall be at least 4 inches in height. Vehicles reconstructed to appear as an antique vehicle of original manufacture but constructed with current techniques may have bumpers that depict the type of bumper used on the original vehicle when manufactured. Each bumper must be of metal construction no less than 1/8 inch in thickness. Each bumper shall be securely attached to the vehicle with the capabilities of absorbing a reasonable degree of impact. Every bumper shall provide a point of contact between 14 and 22 inches from the level surface upon which the vehicle is standing. A push or tow type vehicle may be equipped with a bumper constructed of material other than metal. Every tire in contact with the road surface, except the front wheel on motor driven cycles, shall be sufficiently covered with fenders or flaps so as to prevent loose objects or matter from being thrown about. All fenders or flaps shall be securely fastened to the vehicle. Every fender shall meet the tire covering requirements set forth in section MVD 5.63 Wis. Adm. Code except vehicles reconstructed to appear as an antique vehicle of original manufacture but constructed with current techniques may have fenders that depict the type of fender used on the original vehicle when manufactured. Every motor vehicle shall be equipped with an enclosure providing adequate coverage for engine pulleys, belts, chains and all external moving parts. The enclosure shall be made of rigid material. The rigid material used may be mesh if the openings do not exceed 1/4 inch. Vehicles originally manufactured as a recreational vehicle for off highway operation will not be eligible for registration. The burden of proof shall be on the manufacturer to prove that the vehicle under consideration does meet the federal requirements for highway operation in cases where such use is questionable. Such vehicles include, but are not limited to, snowmobiles, mini-bikes, go-carts and all terrain vehicles. It shall be unlawful for any vehicle to be operated on a highway if:

- (a) The vehicle is not equipped with a bumper on the front and a bumper on the rear.

- (b) Any bumper is inadequate or not securely mounted.
- (c) The vehicle is not equipped with fenders.
- (d) Any fender is not adequate or is not securely fastened to the vehicle.
- (e) The vehicle is not equipped with a moving parts enclosure or the enclosure does not provide adequate coverage.
- (f) The vehicle has not been properly inspected.
- (g) The vehicle is not equipped with the required steering wheel.
- (h) The vehicle does not have required braking.

History: Cr. Register, March, 1974, No. 219, eff. 4-1-74; am. Register, January, 1975, No. 241, eff. 2-1-76.

Subchapter X REGISTRATION AND IDENTIFICATION

MVD 5.67 Registration and identification. (1) The identification and registration plates of every vehicle shall be maintained in proper condition and in conformity with this section. It shall be unlawful for any vehicle to be operated on a highway if:

- (a) Any registration plate is missing, obliterated or obscured.
- (b) Any registration plate is not firmly attached to the vehicle.
- (c) The engine or identification number is missing, obliterated or altered.

History: Cr. Register, March, 1974, No. 219, eff. 4-1-74.

Next page is numbered 43