

Chapter ILHR 42

REPAIRS, ALTERATIONS AND MISCELLANEOUS
REQUIREMENTS

Subchapter I—Welded Repairs and Alterations	ILHR 42.20 Repairs to noncode vessels (p. 69)
ILHR 42.01 General requirements (p. 51)	Subchapter II—Riveted Repairs
ILHR 42.02 General rules for repairs (p. 52)	ILHR 42.25 Riveted patches (p. 72)
ILHR 42.03 General rules for alterations (p. 53)	Subchapter III—Rerating and Derating
ILHR 42.04 Reports (p. 54)	ILHR 42.30 Rerating of a boiler or pressure vessel (p. 72)
ILHR 42.05 Hydrostatic and nondestructive tests (p. 55)	ILHR 42.31 Derating of a boiler or pressure vessel (p. 72)
ILHR 42.06 Welding procedure specifications (p. 55)	Subchapter IV—Safety and Safety Relief Valve Repairs
ILHR 42.07 Welders (p. 55)	ILHR 42.35 Safety and safety relief valve repairs (p. 73)
ILHR 42.08 Welded repairs of cracks (p. 55)	Subchapter V—Secondhand Vessels
ILHR 42.09 Wasted areas (p. 58)	ILHR 42.40 Application (p. 76)
ILHR 42.10 Seal welding (p. 58)	ILHR 42.41 Existing vessels (p. 76)
ILHR 42.11 Re-ending and piercing tubes (p. 63)	ILHR 42.42 Vessels from out-of-state (p. 76)
ILHR 42.12 Materials (p. 63)	ILHR 42.43 Lap seam boilers (p. 76)
ILHR 42.13 Replacement pressure parts (p. 63)	ILHR 42.44 Prohibited boilers (p. 76)
ILHR 42.14 Welding procedures (p. 63)	ILHR 42.45 Inspection and testing (p. 76)
ILHR 42.15 Preheating (p. 64)	ILHR 42.46 Installation (p. 76)
ILHR 42.16 Postweld heat treatment (p. 64)	Subchapter VI—Pressure Vessels in Petroleum Refineries
ILHR 42.17 Welded patches (p. 65)	ILHR 42.50 General requirements (p. 77)
ILHR 42.18 Stays (p. 69)	ILHR 42.51 Adoption of API standard (p. 77)
ILHR 42.19 Additional acceptable repair methods (p. 69)	

Note: Chapter ILHR 42 as it existed on February 29, 1988, was repealed and a new chapter ILHR 42 was created effective March 1, 1988.

Subchapter I — Welded Repairs and Alterations

ILHR 42.01 General requirements. (1) **ACCEPTABLE METHODS.** Welded repairs or alterations to any boiler or pressure vessel or their fittings, settings, or appurtenances shall be completed in accordance with the requirements of ss. ILHR 42.01 to 42.20. Other methods may be acceptable provided they are approved by the department. In the absence of specific rules, the rules for new construction shall apply. Except as provided in s. ILHR 42.02 (1), no welded repair or alteration may be made without the prior approval of an authorized inspector who shall, if it is considered necessary, inspect the object before granting an approval.

(2) **ACCEPTANCE OF REPAIRS AND ALTERATIONS.** Repairs or alterations shall be acceptable to the authorized inspection agency responsible for the inservice inspection of the boiler or pressure vessel. It shall be the responsibility of the organization making the repair or alteration to provide for inspection, documentation and certification of the work and to ensure prior acceptance of the procedures for the work by the inspection agency responsible for inservice inspection of the boiler or pressure vessel.

History: Cr. Register, February, 1988, No. 386, eff. 3-1-88.

Register, February, 1988, No. 386

ILHR 42.02 General rules for repairs. (1) **AUTHORIZATION.** Repairs to boilers and pressure vessels shall be performed by an organization in possession of a valid National Board repair "R" certificate of authorization, a valid ASME certificate of authorization or a valid weld repair program which has been reviewed and verified by the department or an authorized inspection agency. The repair organization shall have a documented quality control program containing a description of the scope of work they intend to perform with supporting welding procedures and qualification reports in accordance with the ASME Code Section IX. Welded repairs of a routine nature as specified in the scope of the repair organization's quality control program may be performed without prior approval of the authorized inspector.

Note 1: See s. ILHR 41.06 for penalties for violations of these rules.

Note 2: The department will assist an organization in preparing a quality control program for welded repairs that will comply with the intent of ss. ILHR 42.01 and 42.02. Organizations who hold ASME certificates or National Board "R" certificates are already in possession of approved quality control programs.

(2) **EXAMPLES OF REPAIRS.** Repairs shall be work such as, but not limited to, the following examples:

(a) Welded repairs or replacements of pressure parts or attachments that have failed in a weld or in the base material;

(b) The addition of welded attachments to pressure parts such as, but not limited to:

1. Studs for insulation or refractory lining,
2. Hex steel or expanded metal for refractory lining,
3. Ladder clips,
4. Brackets,
5. Tray support rings,
6. Corrosion-resistant strip lining,
7. Corrosion-resistant weld overlay, and
8. Weld build-up of wasted areas.

(c) Replacement of heat exchanger tube sheets in accordance with the original design;

(d) Replacement of boiler or heat exchanger tubes where welding is involved;

(e) In a boiler, a change in the arrangement of tubes in furnace walls, economizer or superheater sections;

(f) Replacement of pressure retaining parts identical to those existing on the boiler or pressure vessel and described on the original manufacturer's data report such as, but not limited to:

1. Replacement of furnace floor tubes or sidewall tubes, or both, in a boiler,
2. Replacement of a shell or head in accordance with the original design,

3. Rewelding a circumferential or longitudinal seam in a shell or head, and

4. Replacement of nozzles;

(g) Installation of new nozzles or openings of such a size that reinforcement is not a consideration, such as the installation of a 3-inch pipe size nozzle to a shell or head of 3/8-inch or less in thickness, or the addition of a 2-inch pipe size nozzle to a shell or head of any thickness;

(h) The addition of a nozzle where reinforcement is a consideration may be considered to be a repair provided the nozzle is identical to one in the original design, is located in a similar part of the vessel, and is not closer than 3 times its diameter from another nozzle. The addition of such a nozzle shall be restricted by any service requirements;

(i) The installation of a flush patch to a boiler or pressure vessel;

(j) The replacement of a shell course in a cylindrical pressure vessel;

(k) Welding of gage holes;

(l) Welding of wasted or distorted flange faces;

(m) Replacement of slip-on flanges with weld neck flanges or vice versa; and

(n) Seal welding of butt straps and rivets.

History: Cr. (2) Register, February, 1988, No. 386, eff. 3-1-88; cr. (1) eff. 12-1-88.

ILHR 42.03 General rules for alterations. (1) **AUTHORIZATION.** Alterations to boilers and pressure vessels, with the exception of rerating as specified in s. ILHR 42.30, shall be performed by an organization in possession of a valid ASME certificate of authorization, provided the alterations are within the scope of the authorization.

(2) **NAMEPLATE.** (a) The organization responsible for the preparation of the report of alteration shall also be responsible for adding a stamping or nameplate to the boiler or pressure vessel.

(b) The stamping or nameplate shall be applied adjacent to the original manufacturer's stamping or nameplate in letters at least 5/32 inch high.

(c) The stamping or nameplate for all alterations to a boiler or pressure vessel shall be as follows:

ALTERED BY _____	
_____ (MAWP)	PSIG AT _____ °F (Temp)
_____ (Manufacturer's Alteration Number, if used)	
_____ (Date Altered)	

(3) **REPORTS.** A copy of the original manufacturer's data report and any required manufacturer's partial data reports shall be a part of the completed report of alteration and shall be attached thereto. Where the manufacturer's data report is unavailable, documentation acceptable to the department shall be submitted.

(4) **TEST.** A pressure test shall be applied after the alteration has been completed, at a pressure of at least the operating pressure, but not to exceed 150% of the maximum allowable working pressure. In lieu of a pressure test, if approved by the authorized inspector, radiographic testing or ultrasonic testing may be utilized.

Note: Where water is used in a hydrostatic test, the temperature of the water should not be less than 70°F and the maximum temperature during inspection should not exceed 120°F. If a test is conducted at 1-1/2 times the maximum allowable working pressure (MAWP) and the owner specifies a temperature higher than 120°F, the pressure should be reduced to the MAWP and the temperature should be reduced to 120°F for the close examination.

(5) **EXAMPLES OF ALTERATIONS.** Alterations shall be work such as, but not limited to the following examples:

(a) To increase the maximum allowable working pressure or temperature of a boiler or pressure vessel regardless of whether or not a physical change was made to the boiler or pressure vessel;

(b) The addition of new nozzles or openings in a boiler or pressure vessel except those classified as repairs;

(c) A change in the dimensions or contour of a pressure vessel;

(d) In a boiler, an increase in any heating surface which results in increasing the heat output or the final temperature above that specified in the original design;

(e) The addition of a pressurized jacket to a pressure vessel;

(f) Replacement of a pressure retaining part in a boiler or pressure vessel with a material of different nominal strength or nominal composition from that used in the original design; and

(g) A decrease in the minimum temperature such that additional mechanical tests are required as specified in ASME code section VIII.

History: Cr. Register, February, 1988, No. 386, eff. 3-1-88.

ILHR 42.04 Reports. (1) **GENERAL.** Except as provided in sub. (2), anyone making welded repairs or alterations in accordance with these rules shall furnish the department with a report of every welded repair or alteration. The report shall be signed by the authorized inspector who inspected or approved the repair or alteration. The owner of the equipment shall retain a copy of the report for review by an authorized inspector. The report shall contain the information indicated on department form SB-190 or National Board Form R-1. Form SB-190 shall be filed by organizations who do not possess an ASME certificate of authorization or a National Board R certificate.

Note: See Appendix A for sample copies of forms SB-190 and R-1.

(2) **EXEMPTIONS.** The following items require the prior approval of the authorized inspector but are exempt only from the reporting requirements of sub. (1):

Register, February, 1988, No. 386

- (a) The welded repair or replacement of tubes in boilers or pressure vessels; and
- (b) The welded repair or replacement of piping, nozzles, valves and fittings of 2-inch nominal pipe sizes and smaller.
- (3) OTHER REQUIREMENTS. All other requirements of this subchapter shall apply.

History: Cr. Register, February, 1988, No. 386, eff. 3-1-88.

ILHR 42.05 Hydrostatic and nondestructive tests. If, in the opinion of the authorized inspector, a hydrostatic test is necessary, the test shall be applied at a pressure of at least the operating pressure, but not to exceed 150% of the maximum allowable working pressure. In lieu of a hydrostatic test, if approved by the authorized inspector, radiographic testing, ultrasonic testing, or other applicable nondestructive testing of the repair may be utilized. All tests shall be applied after the repair has been completed.

Note: Where water is used in a hydrostatic test, the temperature of the water should not be less than 70°F and the maximum temperature during inspection should not exceed 120°F. If a test is conducted at 1-1/2 times the maximum allowable working pressure (MAWP) and the owner specifies a temperature higher than 120°F, the pressure should be reduced to the MAWP and the temperature should be reduced to 120°F for the close examination.

History: Cr. Register, February, 1988, No. 386, eff. 3-1-88.

ILHR 42.06 Welding procedure specifications. Anyone undertaking repairs or alterations shall have available at the job site a written welding procedure specification acceptable to the authorized inspector that shall be followed in making the necessary repair and also a record of procedure qualification tests. Welding procedure specifications shall have been prepared and qualified in accordance with the requirements of section IX of the ASME code.

History: Cr. Register, February, 1988, No. 386, eff. 3-1-88.

ILHR 42.07 Welders. (1) WELDER QUALIFICATIONS. Anyone undertaking repairs or alterations shall have available at the job site records of welder qualification tests showing that each welder to be employed on the work has satisfactorily passed tests as prescribed in section IX of the ASME code.

(2) WELDING TESTS. Preparation of welding procedure specifications and the conducting of tests of procedures and welders shall be the responsibility of the party undertaking repairs or alterations. Before repairs or alterations are started, the inspector shall examine the written welding procedure and records of qualification tests to determine if procedures and welders have been properly qualified as required in section IX of the ASME code. Witnessing of the tests by the inspector is not mandatory, but the inspector shall have the right to call for and witness the making of test coupons by any welder, at any time, and to observe the physical testing of the coupons.

History: Cr. Register, February, 1988, No. 386, eff. 3-1-88.

ILHR 42.08 Welded repairs of cracks. (1) REMOVAL OF DEFECTS. A repair of a defect, such as a crack in a welded joint or base material, may not be made until the defect has been removed. A suitable nondestructive examination method shall be used to assure complete removal of the defect. If the defect penetrates the full thickness of the material, the re-

Register, February, 1988, No. 386

ILHR 42

pair shall be made with a complete penetration weld such as a double butt weld or a single butt weld with or without backing.

Note: Before repairing a cracked area, care should be taken to investigate its cause and to determine its extent. Where circumstances indicate that the crack is likely to recur, consideration should be given to removing the cracked area and installing a patch or other corrective measures.

(2) CRACKS IN UNSTAYED AREAS. Cracks in unstayed shells, drums or headers of boilers or pressure vessels may be repaired by welding, providing the cracks do not extend between rivet holes in a longitudinal seam or parallel to a rivet seam within 8 inches, measured from the nearest caulking edge. The total length of any one such crack may not exceed 8 inches. Cracks of a greater length may be welded, provided the complete repair is radiographed and stress relieved in accordance with s. ILHR 42.16. Cracks in unstayed areas shall be repaired as specified in Figure 42.08-1 or by other equivalent methods.

(3) CRACKS IN STAYED AREAS. Cracks of any length in stayed areas may be repaired by fusion welding except that multiple or star cracks radiating from rivet or staybolt holes shall not be welded. Cracks in stayed areas shall be repaired as specified in Figure 42.08-1 or by other equivalent methods.

(4) CRACKS IN UNSTAYED FURNACES. Cracks of any length in unstayed boiler furnaces may be welded, provided the welds are thermally stress relieved in accordance with s. ILHR 42.16. Welds applied from one side only shall be subject to the approval of the authorized inspector. Field repair of cracks at the knuckle or the turn of the flange of the furnace opening are prohibited unless specifically approved by the department.

Figure 42.08-1

RIVET AND STAYBOLT HOLE CRACKS

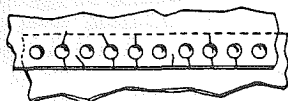
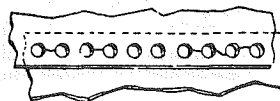
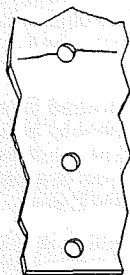
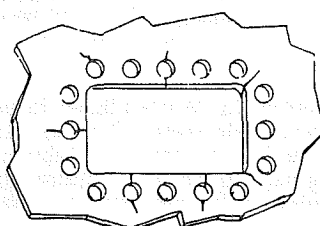
*Fire Cracks at Girth Seams**Circumferential Cracks at Girth Seams**Cracks in Stayed Plates**Fire Cracks at Door Openings*

Cracks radiating from rivet or staybolt holes may be repaired if the plate is not seriously damaged. If the plate is seriously damaged, it shall be replaced. The repair method shall be as follows:

- a. Prior to welding, the rivets or staybolts from which the cracks extend and the adjacent rivets or staybolts shall be removed.
- b. In riveted joints, tack bolts shall be replaced in alternate holes to hold the plate laps firmly.
- c. The cracks shall then be prepared for welding by chipping, grinding or gouging.
- d. In riveted joints, cracks which extend past the inner edge of the plate lap shall be welded from both sides.
- e. Rivet holes shall be reamed before new rivets are driven.
- f. Threaded staybolt holes shall be retapped and new staybolts properly driven and headed.

History: Cr. Register, February, 1988, No. 386, eff. 3-1-88.

ILHR 42

ILHR 42.09 Wasted areas. (1) **SHELLS, DRUMS AND HEADERS.** Wasted areas in stayed and unstayed shells, drums and headers may be built up by welding provided that in the judgement of the authorized inspector the strength of the structure will not be impaired. Where extensive weld build-up is employed, the authorized inspector may require an appropriate method of nondestructive examination for the complete surface of the repair. Wasted areas shall be built up by welding as specified in Figure 42.09-1 or by other equivalent methods.

(2) **ACCESS OPENINGS.** Wasted areas around access openings may be built up by welding provided that in the judgement of the authorized inspector the strength of the structure will not be impaired, or they shall be repaired as specified in Figure 42.09-2 or by other equivalent methods. In boilers, the area to be repaired may not be closer than 2 inches from any knuckle.

(3) **FLANGES.** (a) Wasted flange faces may be cleaned thoroughly and built up with weld metal. Built-up flange faces should be machined in place, if possible, and shall be machined to a thickness not less than that of the original flange or that required by calculations in accordance with the provisions of the applicable section of the ASME code.

(b) Wasted flange faces may also be remachined in place without building up with weld metal provided the metal removed in the process does not reduce the thickness of the flange to a measurement below that calculated in par. (a).

(c) Flanges that leak because of warpage or distortion and that cannot be repaired shall be replaced with new flanges that have at least the dimensions conforming to the applicable section of the ASME code.

(4) **TUBES.** Wasted areas on tubes may be repaired by welding provided that in the judgement of the authorized inspector the strength of the tube has not been impaired. Where deemed necessary, competent technical advice shall be obtained from the manufacturer or from another qualified source. This may be necessary when considering such items as size limitations of repaired areas, minimum tube thickness to be repaired, tube environment, location of the tube in the boiler and other similar conditions.

History: Cr. Register, February, 1988, No. 386, eff. 3-1-88.

ILHR 42.10 Seal welding. (1) **SEAL WELDING OF TUBES.** Tubes may be seal welded provided the ends of the tube have sufficient wall thickness to prevent burn-through and the requirements of the appropriate sections of the ASME code are satisfied. Seal welding of tubes shall be done as specified in Figure 42.10-1 or by other equivalent methods.

(2) **SEAL WELDING OF RIVETED JOINTS.** Edges of butt straps or of plate laps and nozzles or connections attached by riveting may be restored to original dimensions by welding. Seal welding may not be used except with the special approval of the authorized inspector, and in no case where cracks are present in riveted areas. Seal welding shall be done as specified in Figure 42.10-2 or by other equivalent methods.

History: Cr. Register, February, 1988, No. 386, eff. 3-1-88.

Figure 42.09-1
WELD BUILD-UP OF WASTED AREAS

RIVETS AND STAYBOLTS

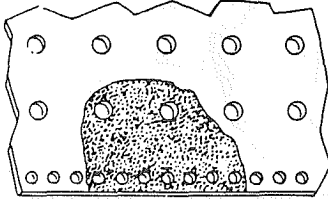

- a. Prior to welding, the rivets or staybolts in the wasted area shall be removed.
- b. Threaded staybolt holes shall be retapped after welding.
- c. Rivet holes shall be reamed after welding.
- d. Welding may not cover rivet or staybolt heads.

TUBESHEET

- a. Prior to welding, the tubes in the wasted area shall be removed.
- b. After welding, the tube holes may be reamed before new tubes are installed.

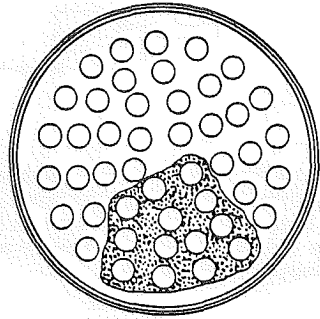

Wasted areas in stayed and unstayed surfaces may be built up by welding provided that in the judgment of the authorized inspector the strength of the structure will not be impaired. Where extensive weld build-up is employed, the authorized inspector may require an appropriate method of nondestructive examination for the complete surface of the repair.

Figure 42.09-2
REPAIRS FOR ACCESS OPENINGS

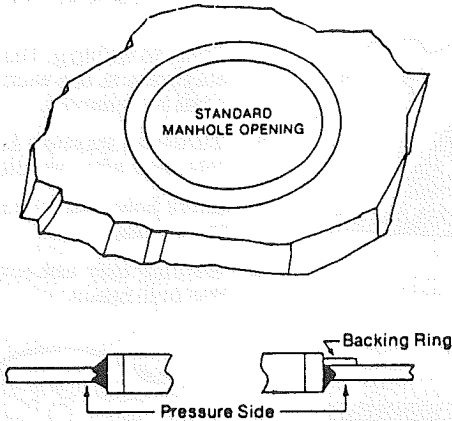

A badly wasted manhole flange may be removed and replaced with a ring-type frame as shown above. The requirements of s. ILHR 42.17 (1) for flush patches shall be met. A full penetration weld shall be required. The weld may either be double welded or welded from one side with or without a backing ring.

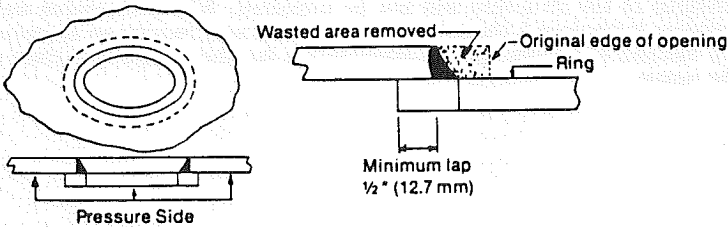

A badly wasted area around a handhole opening shall be repaired by adding a ring as shown above on the inside of the object.

Figure 42.10-1
SEAL WELDING OF TUBES

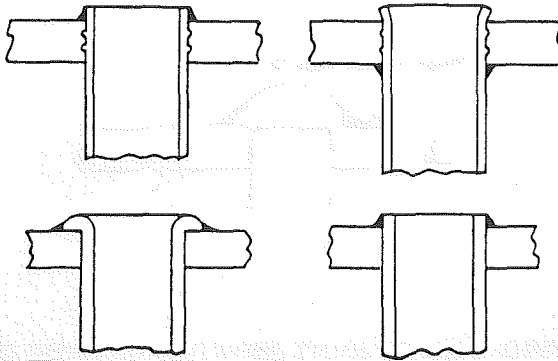

Tubes may be seal welded provided the ends of the tubes have sufficient wall thickness to prevent burn through. Seal welding shall be applied with a maximum of three light layers in lieu of one or two heavy layers.

In watertube boilers, tubes may be seal welded on the inside or outside of the tubesheet.

Figure 42.10-2

SEAL WELDING OF RIVETED JOINTS

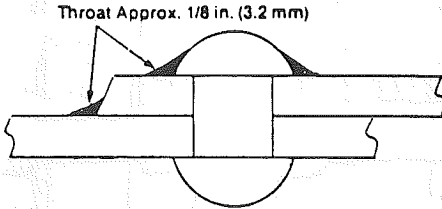

TYPICAL RIVET JOINT SHOWING SEAL WELD

Seal welding of riveted joints requires the approval of the department. Seal welding may not be considered a strength weld. Seal welding shall be applied in one light layer if practicable, but not more than two layers shall be used.

Prior to welding, the area shall be examined by an appropriate method of nondestructive examination to assure that there are no cracks radiating from the rivet holes. If necessary, the rivets shall be removed to assure complete examination of the area. Seal welding may not be performed if cracks are present in riveted areas.

ILHR 42.11 Re-ending and piecing tubes. Re-ending or piecing of tubes or pipes in either fire tube or water tube boilers is permitted provided the thickness of the remaining tube or pipe is not less than 90% of that required by the applicable section of the ASME code.

History: Cr. Register, February, 1988, No. 386, eff. 3-1-88.

ILHR 42.12 Materials. The materials used in making repairs or alterations shall conform to the requirements of the applicable section of the ASME code. Materials shall be of known weldable quality, have at least the minimum physical properties of the material to be repaired and be compatible with the original material. The thickness of any patch shall be at least equal to, but not more than 1/8-inch greater than, the material being patched. Carbon or alloy steel having a carbon content of more than 0.35% may not be welded.

History: Cr. Register, February, 1988, No. 386, eff. 3-1-88.

ILHR 42.13 Replacement pressure parts. Replacement parts shall be classified as follows:

(1) **PARTS ASSEMBLED BY FORMING.** Replacement parts which will be subject to internal or external pressure and that consist of materials which may be formed or assembled to the required shape by bending, forging or other forming methods, but on which no shop fabrication welding is performed, may be supplied as material. Material and part identification shall be supplied in the form of bills of materials and drawings with ASME code compliance certified in a statement by the parts supplier.

Note: Examples include seamless or welded tubes or pipe supplied separately or in bundles; forged nozzles; heads or tube sheets forged or machined from a single piece of material; subassemblies of tubes or pipe attached together mechanically.

(2) **WELDED PARTS NOT REQUIRING INSPECTION.** Replacement parts which will be subject to internal or external pressure and that are preassembled by welding, but on which shop inspection is not required by the ASME code, shall have the welding performed in accordance with section IX and other applicable sections of the ASME code. The replacement part assembly identification shall be supplied in the form of bills of material and drawings. The supplier or manufacturer shall certify that the material, design and fabrication are in accordance with the applicable section of the ASME code.

Note: Examples include boiler furnace panel wall or floor assemblies; prefabricated openings in boiler furnace walls such as burner openings, air ports, inspection openings or soot blower openings.

(3) **WELDED PARTS REQUIRING INSPECTION.** Replacement parts which will be subject to internal or external pressure and that are fabricated by welding and which require shop inspection by an authorized inspector, shall be fabricated by a manufacturer having an ASME certificate of authorization and the appropriate code symbol stamp. The item shall be inspected, and stamped with the applicable code symbol and the word "PART". A completed manufacturer's partial data report shall be supplied by the manufacturer.

History: Cr. Register, February, 1988, No. 386, eff. 3-1-88.

ILHR 42.14 Welding procedures. Groove welds shall completely penetrate the thickness of the material being welded. If possible, welding shall be applied from both sides of the plate or a backing strip or ring

Register, February, 1988, No. 386

may be used to ensure complete penetration. Manually applied welds shall have a convex surface on both sides if applied on both sides of the plates being joined, or on one side if welding is applied from one side only. Valleys and undercutting at edges of welded joints are not permitted. The reinforcement may be chipped, ground, or machined off flush with the base metal, if so desired, after the welding has been completed.

History: Cr. Register, February, 1988, No. 386, eff. 3-1-88.

ILHR 42.15 Preheating. (1) **GENERAL.** Preheating may be required during welding to assist in completion of the welded joint. Where deemed necessary, advice shall be sought from a qualified source.

Note: See ASME code section VIII Appendix R for further explanatory information.

(2) **PREHEAT AND INTERPASS TEMPERATURES.** The welding procedure specification and qualification for the material being welded shall specify the preheat and interpass temperature requirements.

History: Cr. Register, February, 1988, No. 386, eff. 3-1-88.

ILHR 42.16 Postweld heat treatment. (1) **GENERAL.** In repairing carbon or low alloy steels, postweld heat treatment shall be required if it would be required for new construction by the ASME code.

Note: Under certain conditions, postweld heat treatment as outlined in sub. (1) may be inadvisable or impractical. In these instances, any other method of postweld heat treatment or special welding method acceptable to the authorized inspector may be used. Examples of special welding methods for P1 and P3 materials are described in sub. (3). Where deemed necessary, competent technical advice should be obtained from the manufacturer of the object or from another qualified source.

(2) **ALTERNATIVE METHODS.** When methods other than postweld heat treatment are used, the authorized inspector shall be assured that the requirements of sub. (3) are met.

(3) **WELDING METHODS AS ALTERNATIVES TO POSTWELD HEAT TREATMENT.** Two welding methods that may be used as alternatives to postweld heat treatment are given in pars. (a) and (b) as a general guide. The use of these alternatives is limited to P1 and P3 steels, and to the more routine repairs required in boiler and pressure vessel maintenance. They may not be used in highly stressed areas, or if service conditions are conducive to stress corrosion cracking or, in some cases, to hydrogen embrittlement.

(a) *Method 1, higher preheat temperature.* 1. Material applicability. The use of method 1 shall be limited to P1 groups 1, 2 and 3 steels and P3 groups 1 and 2, except Mn-Mo, steels.

2. Method details. The materials to be welded shall be preheated to at least 300°F and maintained at this temperature during welding. The 300°F temperature shall be checked to assure that 4 inches of the steel on each side of the joint, or 4 times the plate thickness, whichever is greater, will be maintained at the minimum preheat temperature. The maximum interpass temperature shall be 450°F.

Note: In the use of this method it should be ascertained that the notch ductility in the welded condition is adequate at operating and pressure test temperatures. When this alternative meets the above requirements, any code credit for postweld heat treatment can be continued.

Register, February, 1988, No. 386

(b) *Method 2, half bead welding technique.* 1. Material applicability. The use of method 2 shall be limited to groups 1, 2 and 3 for both P1 and P3 steels.

2. Limitations. a. The weld metal shall be deposited by the manual shielded metal arc process using low hydrogen electrodes. The maximum bead width shall be 4 times the electrode core diameter.

b. The depth of the repair may not be greater than 3/8-inch or 10% of the base metal thickness, whichever is less, and the individual area may not be greater than 10 square inches.

c. When this method is used, it shall require the approval of the department. The authorized inspector shall assure that the method has been qualified in accordance with the guidelines of section IX of the ASME code.

3. Method details. a. Step 1. The weld area shall be preheated and maintained at a minimum temperature of 350°F during welding. The maximum interpass temperature shall be 450°F.

b. Step 2. The initial layer of weld metal shall be deposited over the entire area with a 1/8-inch maximum diameter electrode. Approximately one-half the thickness of this layer shall be removed by grinding before depositing subsequent layers. Subsequent layers shall be deposited with a 5/32-inch maximum diameter electrode in a manner to ensure tempering of the prior beads and their heat affected zones. Partial removal of these subsequent layers is not required. A final temper bead weld shall be applied to a level above the surface being repaired without contacting the base material but close enough to the edge of the underlying weld bead to assure tempering of the base material heat affected zone.

c. Step 3. The weld area shall be maintained at a temperature of 400-500°F for a minimum period of 4 hours after completion of the weld repair. The final temper bead reinforcement layer shall be removed substantially flush with the surface of the base material.

(4) JOINTS BETWEEN AUSTENITIC STAINLESS STEELS. Postweld heat treatment is neither required nor prohibited for joints between austenitic stainless steels. It may not be attempted except in accordance with the recommendations of the manufacturer of the material or the requirements of the applicable section of the ASME code.

Note: See ASME code, section VIII, division 1, paragraph UHA-105.

(5) PEENING. In lieu of postweld heat treatment of carbon steels, peening or other methods acceptable to the authorized inspector may be used.

History: Cr. Register, February, 1988, No. 386, eff. 3-1-88.

ILHR 42.17 Welded patches. (1) **FLUSH PATCHES.** The weld around a flush patch shall be a full penetration weld and the accessible surfaces shall be ground flush where required by the applicable section of the ASME code. The welds shall be subjected to the nondestructive examination method used in the original construction or an acceptable alternate. Flush welded patches shall be applied as specified in Figure 42.17-1 or by other equivalent methods.

(2) **TUBE PATCHES.** In some situations it is necessary to weld a flush patch on a tube, such as when replacing tube sections and accessibility

Register, February, 1988, No. 386

around the complete circumference of the tube is restricted, or when it is necessary to repair a small bulge. This is referred to as a window patch. Window patches shall be applied as specified in Figure 42.17-2 or by other equivalent methods.

(3) LAPPED AND FILLET WELDED PATCHES. Lapped and fillet welded patches may be applied provided they are not exposed to radiant heat. Lapped and fillet welded patches may be applied on the pressure side of the sheet. The maximum diameter of the opening repaired may not exceed 8 inches or 16 times the thickness of the plate. Lapped and fillet welded patches shall have a minimum lap of 1/2 inch. If the area to be patched includes a riveted seam, rivets shall be removed before the patch is applied and new rivets driven before the patch is welded at the edges. New staybolts shall be installed in the patched area, and the heads of the staybolts shall be covered by welding.

History: Cr. Register, February, 1988, No. 386, eff. 3-1-88.

Figure 42.17-1
FLUSH PATCHES

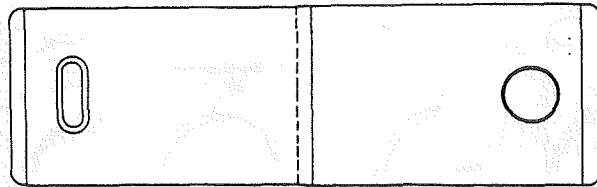

FLUSH PATCHES IN UNSTAYED AREAS

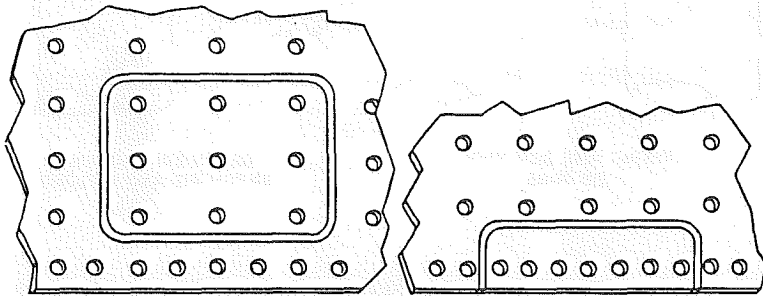

FLUSH PATCHES IN STAYED AREAS

Before installing a flush patch, the defective metal shall be removed until sound metal is reached. The patch shall be rolled or pressed to the proper shape or curvature. The edges shall align without overlap.

In stayed areas, the weld seams shall come between staybolt rows or riveted seams.

Patches shall be made from material that is at least equal in quality and thickness to the original material.

Patches may be of any shape or size. Corners of patches shall have a radius of such size as is necessary to avoid creating a stress point.

Figure 42.17-2
TUBE WINDOW PATCHING METHOD

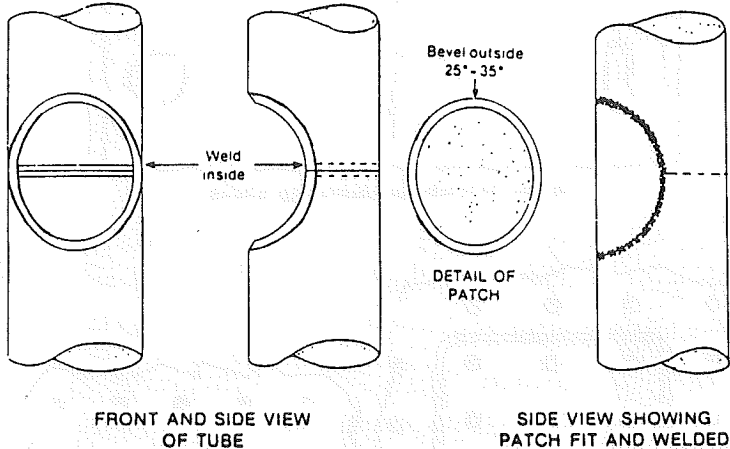

It may be necessary to weld a flush patch on a tube, since in some situations, accessibility around the complete circumference of the tube is restricted. Window patches shall be applied as follows:

- The patch shall be made from tube material of the same type, diameter and thickness as the one being repaired.
- Fitup of the patch is important to weld integrity. The root opening shall be uniform around the patch.
- The gas tungsten arc welding process shall be used for the initial pass on the inside of the tube and for the initial pass joining the patch to the tube.
- The balance of the weld may be completed by any appropriate welding process.

ILHR 42.18 Stays. Threaded stays may be replaced by welded-in stays provided that in the judgment of the authorized inspector the plate adjacent to the staybolt has not been materially weakened by wasting away. All requirements of the ASME code governing welded-in stays shall be met, except that stress relieving other than thermal may be used as provided in s. ILHR 42.16.

History: Cr. Register, February, 1988, No. 386, eff. 3-1-88.

ILHR 42.19 Additional acceptable repair methods. Repairs and repair methods not covered in this chapter may be used if acceptable to the authorized inspector. Additional methods illustrated in Figures 42.19-1 and 42.19-2 are acceptable if performed as specified in the figures.

History: Cr. Register, February, 1988, No. 386, eff. 3-1-88.

ILHR 42.20 Repairs to noncode vessels. Welded repairs or alterations to pressure vessels not covered by section VIII of the ASME code shall be performed in accordance with the pressure vessel manufacturer's recommendations and section IX of the ASME code. If the pressure vessel manufacturer is no longer in business, recommendations of a pressure vessel design engineer may be acceptable.

History: Cr. Register, February, 1988, No. 386, eff. 3-1-88.

Figure 42.19-1

**ACCEPTABLE REPAIRS FOR CORRODED
OR WORN HEADS OF VERTICAL TUBE
OR SIMILAR TYPE BOILERS**

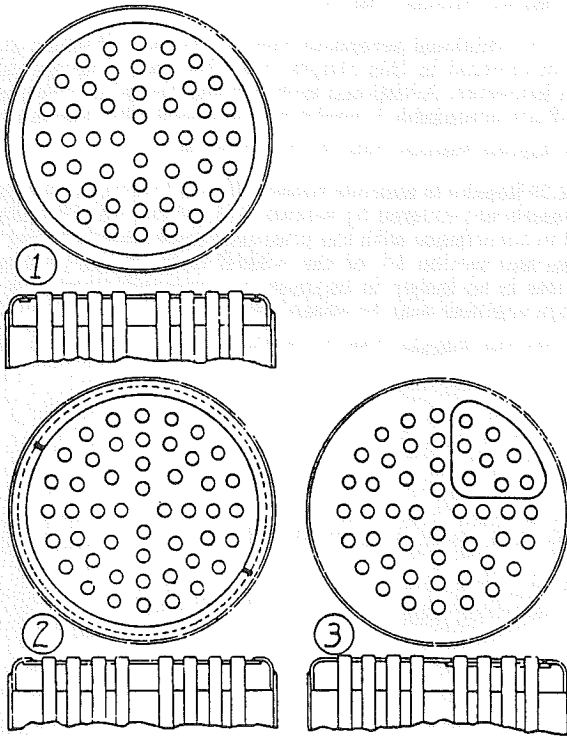

1. Flush Butt Welded Head

With this repair, the old head shall be cut close to the point of tangency of the knuckle of the flange, and the new head, previously drilled for tube holes and beveled for adequate welding groove, shall be butt welded to the flanged section of the old head. A back up ring, inserted in sections if necessary, shall be used to ensure weld penetration for the full head thickness.

2. Lapped and Fillet Welded Head

With this repair, the new head shall be lapped under the flange knuckle of the old head, previously slotted as shown to admit the new head, and then fillet welded at the edge.

3. Segmental or Pie-Shaped Butt Welded Patch

Figure 42.19-2
ACCEPTABLE FURNACE RENEWAL

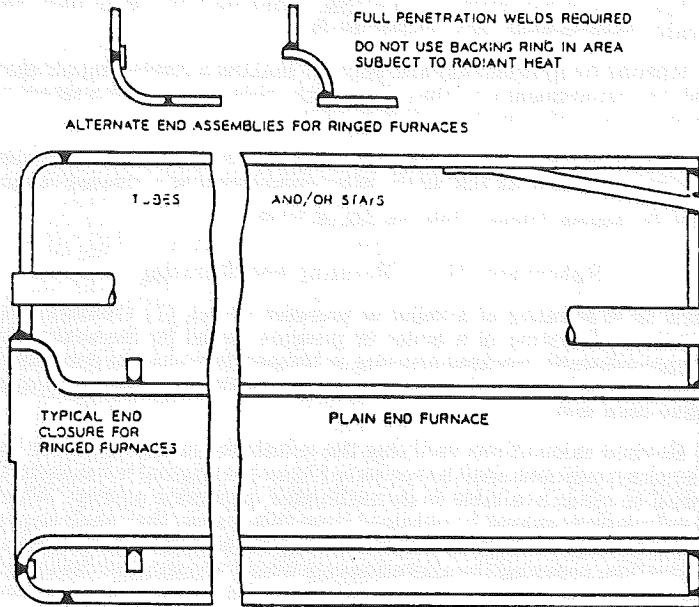

Longitudinal seam in furnace double butt-welded and thermally stress-relieved

For repair, the final joint to each head may be stress-relieved by peening. The furnace may be welded into a riveted boiler by using adaptable end closures. Ringed furnaces shall be thermally stress-relieved after longitudinal seam and rings have been applied.

Subchapter II — Riveted Repairs

ILHR 42.25 Riveted patches. (1) **GENERAL.** When riveted patches are used, they shall be designed and applied using methods acceptable to the department.

Note: Information regarding the use of riveted patches is available from the department and may be found in Wisconsin Administrative Code chapters Ind 41-42, Boiler and Pressure Vessel Code, Register, May, 1974, No. 221.

(2) **MATERIALS FOR RIVETED PATCHES.** Patch material shall meet the applicable requirements of s. ILHR 42.12.

(3) **REPORT OF RIVETED REPAIR.** Anyone making a riveted repair shall furnish the department and the owner of the equipment with a report of the repair as specified under s. ILHR 42.04.

(4) **PRESSURE TEST.** The authorized inspector may require a pressure test, as specified in s. ILHR 42.05, after completion of a riveted repair.

History: Cr. Register, February, 1988, No. 386, eff. 3-1-88.

Subchapter III — Rerating and Derating

ILHR 42.30 Rerating of a boiler or pressure vessel. (1) **GENERAL REQUIREMENTS.** Rerating of a boiler or pressure vessel by increasing the maximum allowable working pressure or temperature shall be considered an alteration and may be done only after the requirements of pars. (a) to (d) have been met.

(a) Revised calculations verifying the suitability of the vessel for the new service conditions shall be requested from the original manufacturer and shall be made available to its authorized inspection agency. Where these calculations cannot be obtained from this source, they shall be prepared by an organization in possession of a valid ASME certificate of authorization, provided the alterations are within the scope of the authorization, and they shall be made available to its authorized inspection agency.

(b) All reratings shall be established in accordance with the requirements of the code to which the boiler or pressure vessel was built, or by computation using the appropriate formulas in the edition of the ASME code listed in Table 41.10, if all essential details are known to definitely comply with this edition of the code.

(c) Current inspection records shall verify that the boiler or pressure vessel is satisfactory for the proposed service conditions.

(d) The boiler or pressure vessel rerating shall be acceptable to the authorized inspection agency performing the periodic inspections of the object under chs. ILHR 41 and 42.

(2) **NAMEPLATE AND REPORT REQUIREMENTS.** The requirements of s. ILHR 42.03 (2)-(4) shall be met and an alteration report shall be submitted in accordance with s. ILHR 42.04.

History: Cr. Register, February, 1988, No. 386, eff. 3-1-88.

ILHR 42.31 Derating of a boiler or pressure vessel. (1) **GENERAL REQUIREMENTS.** Derating of a boiler or pressure vessel by decreasing the maximum allowable working pressure may be done only after the re-
Register, February, 1988, No. 386

quirements of subs. (2) to (4) have been met. Derating may be initiated by the owner or the authorized inspector.

(2) **NAMEPLATE REQUIREMENTS.** When a boiler or pressure vessel is derated, an additional nameplate shall be permanently attached. The nameplate for derating shall be as follows:

DERATED	
_____ PSIG AT _____ °	
(MAWP)	(Temp)

(Wisconsin Registration Number)	

(Date Derated)	

(3) **NAMEPLATE ATTACHMENT.** Attachment of the nameplate shall be witnessed by the authorized inspector.

(4) **REPORTS.** The authorized inspector shall report the derating to the department.

History: Cr. Register, February, 1988, No. 386, eff. 3-1-88.

Subchapter IV — Safety and Safety Relief Valve Repairs

ILHR 42.35 Safety and safety relief valve repairs. (1) **DEFINITIONS.** (a) Repair of a safety valve or safety relief valve means the replacement, remachining or cleaning of any critical part; lapping of seat and disc or any other operation which may affect the flow passage, capacity, function or pressure retaining integrity; and disassembly, reassembly and adjustments which affect the safety valve or safety relief valve function.

(b) Safety valves and safety relief valves on which the seals have been broken shall be subject to the requirements for repairs.

(c) The initial adjustments of a new safety valve or safety relief valve on a boiler or pressure vessel are not considered a repair if made by the manufacturer or assembler of the valve.

(2) **AUTHORIZED REPAIRS.** Repairs to safety valves and safety relief valves shall be performed by an organization in possession of one or more of the following:

(a) ASME V, HV or UV code symbol stamp;

(b) National Board VR stamp covering the work to be performed; or

(c) An owner's program of repair limited to adjustments of set pressure and blowdown performed by trained and qualified people and authorized by the department.

Note: Repairs made in accordance with par. (c) may void original valve manufacturer's warranty.

(3) **AUTHORIZED ADJUSTMENTS.** The department may authorize properly trained and qualified employes of boiler or pressure vessel users to make external adjustments to set pressure and blowdown to safety valves and safety relief valves owned by them provided the adjusted settings and capacities and the date of the adjustment are recorded on a metal tag secured to the seal wire. All external adjustments shall be resealed showing the identification of the organization making the adjustments.

(4) **NAMEPLATES.** (a) Except as provided in sub. (3), when a safety valve or safety relief valve is repaired, a metal repair nameplate stamped with the information required by par. (b) shall be welded or otherwise permanently attached to the valve either above, adjacent to or below the original stamping. On small valves, a metal tag showing the repair nameplate information may be securely attached to the repaired valve.

(b) The information on the valve repair nameplate shall include the name of the repair organization, the symbol stamp and symbol stamp number, and the date of repair. The nameplate shall be as shown in Figure 42.35. If the set pressure has been changed, the new set pressure and capacity shall be indicated and the original nameplate or stamping shall be modified by marking out, although leaving legible, the prior set pressure and capacity. The new capacity shall be based on that for which the valve was originally certified. Only the current repair nameplate need be attached to the valve with the original or duplicate nameplate.

(5) **ILLEGIBLE OR MISSING NAMEPLATES.** (a) When the information on the original manufacturer's nameplate or stamping is illegible, the manufacturer's nameplate or stamping shall be augmented by a nameplate stamped "duplicate" which contains all information required by the applicable section of the ASME code, except the "V" or "UV" symbol and the NB mark. The repair organization nameplate, with the serialized "VR" stamp and other required data specified in sub. (4) (b), shall make the repairer responsible to the owner and the department that the information on the duplicate nameplate data is correct. If the owner specifies a set pressure or blowdown change, these new parameters and new capacity shall be stamped on the duplicate nameplate in addition to appearing on the valve repairer's nameplate.

(b) When the original valve manufacturer's nameplate is missing, the repair organization may not perform repairs to the valve under the "VR" program unless the valve can be positively identified and original nameplate data can be obtained from the original valve manufacturer, the repairer's inhouse sources or the National Board capacity certification. Valves that can be positively identified shall be equipped with a duplicate nameplate as described in par. (a) as well as the repairer's "VR" stamped nameplate. The repairer's responsibilities for data accuracy as identified in par. (a) shall apply.

History: Cr. Register, February, 1988, No. 386, eff. 3-1-88.

Register, February, 1988, No. 386

Figure 42.35
VALVE REPAIR NAMEPLATE

(name of valve repair firm)	
_____	_____
(set pressure)	(capacity)

(date of repair)	
No. _____	
(Symbol stamp no.)	

Note #1: The nameplate should be stamped with the valve repair symbol stamp.

Note #2: Capacity should be indicated only when set pressure has been changed.

Subchapter V — Secondhand Vessels

ILHR 42.40 Application. Sections ILHR 42.40 to 42.46 shall apply to secondhand boilers and secondhand pressure vessels.

History: Cr. Register, February, 1988, No. 386, eff. 3-1-88.

ILHR 42.41 Existing vessels. Secondhand boilers and secondhand pressure vessels, originally installed in Wisconsin and not constructed and stamped according to some edition of the ASME Code, may be reinstalled if the maximum allowable working pressure is recalculated with a factor of safety of 6.

History: Cr. Register, February, 1988, No. 386, eff. 3-1-88.

ILHR 42.42 Vessels from out-of-state. Secondhand boilers and secondhand pressure vessels, from out-of-state, shall be constructed and stamped according to some edition of the ASME Code. A copy of the manufacturer's data report shall be furnished to the department for each vessel indicating that it was manufactured originally to the requirements of an earlier edition of the applicable ASME code. If a vessel has been repaired or altered since its fabrication, a copy of the manufacturer's data report, welded repair report or alteration report shall be furnished to the department.

History: Cr. Register, February, 1988, No. 386, eff. 3-1-88.

ILHR 42.43 Lap seam boilers. Secondhand boilers which have lap seam construction and which are larger than 36 inches in diameter shall be limited to a maximum allowable working pressure of not more than 15 pounds per square inch.

History: Cr. Register, February, 1988, No. 386, eff. 3-1-88.

ILHR 42.44 Prohibited boilers. The installation of secondhand boilers which have the longitudinal joint exposed to the intense heat of the furnace is prohibited. The locomotive or inside butt strap may not be considered as strengthening or changing the original type of boiler joint.

History: Cr. Register, February, 1988, No. 386, eff. 3-1-88.

ILHR 42.45 Inspection and testing. (1) **HYDROSTATIC PRESSURE TEST.** Every secondhand vessel shall be inspected and given a hydrostatic pressure test at one and one-half times the maximum allowable working pressure at its new point of installation location before it is placed in operation. The test shall be witnessed by an authorized inspector.

(2) **ALTERNATE TESTS.** When the authorized inspector determines that a hydrostatic test at one and one-half times the maximum allowable working pressure is not possible or desirable, the authorized inspector may accept alternate means to determine if the vessel is safe for its intended use.

Note: Where water is used in a hydrostatic test, the temperature of the water should not be less than 70°F and the maximum temperature during inspection should not exceed 120°F. If a test is conducted at 1-1/2 times the maximum allowable working pressure (MAWP) and the owner specifies a temperature higher than 120°F, the pressure should be reduced to the MAWP and the temperature should be reduced to 120°F for the close examination.

History: Cr. Register, February, 1988, No. 386, eff. 3-1-88.

ILHR 42.46 Installation. Except for vessels exempted in s. ILHR 41.18, all secondhand vessels when reinstalled, shall comply with the ASME

Register, February, 1988, No. 386

codes listed in s. ILHR 41.10 in regard to fittings, appliances, valves, connections, settings and supports. These vessels shall also comply with the installation and certificate of operation requirements in chs. ILHR 41 and 42.

History: Cr. Register, February, 1988, No. 386, eff. 3-1-88.

Subchapter VI — Pressure Vessels in Petroleum Refineries

ILHR 42.50 General requirements. Pressure vessels in petroleum refineries shall comply with the standards specified in the American Petroleum Institute (API) Standard ANSI/API 510 - Pressure Vessel Inspection Code, as adopted by reference in s. ILHR 42.51.

History: Cr. Register, February, 1988, No. 386, eff. 3-1-88.

ILHR 42.51 Adoption of API standard. (1) **CONSENT TO INCORPORATE.** Pursuant to s. 227.21, Stats., the attorney general and the revisor of statutes have consented to the incorporation by reference of the American Petroleum Institute (API) Pressure Vessel Inspection Code, ANSI/API 510-1985.

(2) **INTERIM AMENDMENTS.** Interim amendments of the standard in reference shall have no effect in the state until the time that this section is revised to reflect those changes.

(3) **AVAILABILITY OF STANDARDS.** The standard in reference may be obtained at a reasonable cost from the American Petroleum Institute, 1220 L Street, Northwest, Washington, D.C. 20005.

(4) **FILING OF STANDARDS.** The standard in reference is on file in the offices of the department, the secretary of state and the revisor of statutes.

History: Cr. Register, February, 1988, No. 386, eff. 3-1-88.

APPENDIX A

The material contained in this appendix is for information purposes only. Forms SBD-7678 and SBD-7679 are referred to in ss. ILHR 41.16 and 41.23. Forms SBD-6314 and SB-5204 are referred to in s. ILHR 41.41. Copies of these forms are available from the Division of Safety and Buildings, P.O. Box 7969, Madison, Wisconsin 53707.

Forms SB-190, R-1 and NR-1 are referred to in ss. ILHR 41.56 and 42.04. Copies of form SB-190 are available from the Division of Safety and Buildings. Copies of forms R-1 and NR-1 are available from the National Board, 1055 Crupper Avenue, Columbus, Ohio 43229.

Department of Industry, Labor and Human Relations
Safety and Buildings Division
P.O. Box 7909, Madison, WI 53707
(608) 266-1580

PRESSURE VESSEL INSPECTION REPORT
(Statutory Reference: Chap. 101, Wis. Stats.)
See Reverse Side For Code References

FOR DILHR USE ONLY			
FILE NUMBER	BATCH NUMBER		
INS. CODE	SUM CODE		
INSP FEE	DIST NO.		

1	DATE INSPECTED: MO DAY YEAR	CERTIFICATE EXP. DATE: MONTH YEAR	OWNER NO.:	REGISTRATION NO.:	KIND OF INSPECTION: IS INSPECTION: <input type="checkbox"/> CERTIFICATE <input type="checkbox"/> SPECIAL <input type="checkbox"/> INTERNAL <input type="checkbox"/> EXTERNAL
	OWNER:		NATURE OF BUSINESS:		
2	OWNER'S STREET ADDRESS:			OWNER'S CITY:	STATE ZIP CODE
	USER'S NAME - WHERE OBJECT LOCATED:			SPECIFIC LOCATION OF OBJECT: OBJECT LOCATION COUNTY:	
3	USER'S STREET ADDRESS:			USER'S CITY:	STATE ZIP CODE
4	TYPE: <input type="checkbox"/> AIR TANK <input type="checkbox"/> OTHER			YEAR BUILT	MANUFACTURER:
5	USE: <input type="checkbox"/> STORAGE <input type="checkbox"/> PROCESS <input type="checkbox"/> HEAT EXCHANGE <input type="checkbox"/> OTHER			SIZE:	CUBIC CAPACITY:
6	PRESSURE ALLOWED:		SAFETY VALVES	EXPLAIN IF PRESSURE CHANGED:	
	THIS INSPECTION		PREVIOUS INSPECTION	SET AT	
7	CAN A CERTIFICATE BE ISSUED FOR THIS OBJECT? <input type="checkbox"/> YES (if modifications, list below) <input type="checkbox"/> NO (Explain fully below)			NEXT CERTIFICATE INSPECTION DATE:	MONTH/YEAR HYDRO TEST: <input type="checkbox"/> YES <input type="checkbox"/> NO <input type="checkbox"/> IF YES, PSI DATE
8	COMMENTS:				

9 ITEM	ORDER NO.	REQUIREMENTS (List code violations)

10 COMPLIANCE DATE:	PERSON'S NAME TO WHOM REQUIREMENTS WERE EXPLAINED:	PERSON'S TITLE:
I CERTIFY THIS IS A TRUE REPORT OF MY INSPECTION:		
INSPECTOR SIGNATURE:	CERT. NO.:	EMPLOYED BY:

SBD-7678 (N. 03/87) Copy Distribution: White - DILHR; Green - Inspector; Yellow - Owner

Department of Industry, Labor and Human Relations
BOILER-FIRED PRESSURE VESSEL
 INSPECTION REPORT

Safety and Buildings Division, P.O. Box 7969, Madison, WI 53707
 (Statutory Reference: Chap. 101, Wis. Stats. See Back For Code References)

FIRST INSPECTION <input type="checkbox"/> INSPECTION PERIOD <input type="checkbox"/> 1 YR. <input type="checkbox"/> 3 YR. (266) 266-1580		FOR DILHR USE ONLY FILE NUMBER _____ BATCH NUMBER _____ INS CODE _____ SUM CODE _____ INSP FEE _____ DIST NO _____					
1	DATE INSPECTED: MO. DAY YEAR	CERT. EXP. DATE: MONTH/YEAR	OWNER NO.	REGISTRATION NO.	KIND OF INSPECTION: IS INSPECTION <input type="checkbox"/>	CERTIFICATE <input type="checkbox"/>	SPECIAL <input type="checkbox"/>
2	OWNER:			NATURE OF BUSINESS		INTERNAL <input type="checkbox"/> EXTERNAL <input type="checkbox"/>	
3	OWNER'S STREET ADDRESS:			OWNER'S CITY	STATE:	ZIP CODE	
4	USER'S NAME - WHERE OBJECT LOCATED:			SPECIFIC LOCATION OF OBJECT:		OBJECT LOCATION-COUNTY:	
5	USER'S STREET ADDRESS			USER'S CITY:	STATE:	ZIP CODE	
6	TYPE: <input type="checkbox"/> FT <input type="checkbox"/> WT <input type="checkbox"/> CJ <input type="checkbox"/> Other _____			YEAR BUILT	MANUFACTURER:		
7	USE: <input type="checkbox"/> POWER <input type="checkbox"/> PROCESS <input type="checkbox"/> STEAM HTG. <input type="checkbox"/> HWH <input type="checkbox"/> OTHER _____			FUEL:	FIRING METHOD:	HEATING SURFACE:	
8	PRESSURE ALLOWED: _____			SAFETY VALVES:		EXPLAIN IF PRESSURE CHANGED:	
9	THIS INSPECTION _____ PREV. INSPECTION _____			SET AT _____	TOTAL CAPACITY _____		
10	CAN A CERTIFICATE BE ISSUED FOR THIS OBJECT? <input type="checkbox"/> Yes (if modifications, list below) <input type="checkbox"/> NO (Explain fully below)			NEXT CERTIFICATE INSPECTION DATE:	MONTH/YEAR	HYDRO TEST:	
11	COMMENTS:						
12	9	ITEM	ORDER NO.	REQUIREMENTS (List code violations)			
10 COMPLIANCE DATE		PERSON'S NAME TO WHOM REQUIREMENTS WERE EXPLAINED:			PERSON'S TITLE:		
I CERTIFY THIS IS A TRUE REPORT OF MY INSPECTION:							
SIGNATURE OF INSPECTOR				CERT. NO.	EMPLOYED BY:		

SBDS-7679 (N. 03/87)

Copy Distribution: White - DILHR; Green - Inspector; Yellow - Owner

**BOILER AND PRESSURE VESSEL
INSTALLATION REGISTRATION**

Installing Contractors shall prepare this form in triplicate for each boiler or pressure vessel installed.

Distribute as follows:

WHITE:

Department of
Industry, Labor & Human Relations.

Send to: Safety & Buildings Division
Box 7969, Madison, WI 53707.

YELLOW: Send to owner. PINK: Installer's copy.

STATE OF WISCONSIN
DEPARTMENT OF INDUSTRY, LABOR & HUMAN RELATIONS
SAFETY AND BUILDINGS DIVISION

(Complete appropriate portion)

BOILER:		
<input type="checkbox"/> POWER	<input type="checkbox"/> HEATING	<input type="checkbox"/> MINIATURE
<input type="checkbox"/> PRESSURE VESSEL		
<input type="checkbox"/> NEW	<input type="checkbox"/> USED	

NAME OF USER OR OWNER:			LOCATION OF INSTALLATION:		
STREET ADDRESS:			WIS. REGISTRATION NO.:		NATIONAL BOARD NO.:
CITY:	STATE:	ZIP CODE:	MFR. SERIAL NO.:		OTHER NO.:
NAME OF INSTALLING CONTRACTOR:			SIGNATURE OF INSTALLER:		DATE:
STREET ADDRESS:			CITY:	STATE:	ZIP CODE:

DILHR-SBD 6314 (N. 02/81)

**POWER PIPING
INSTALLATION REGISTRATION**
SBD-5204 (R. 1/82)

FORM SBD-5204

STATE OF WISCONSIN
DEPARTMENT OF INDUSTRY, LABOR AND HUMAN RELATIONS
SAFETY AND BUILDINGS DIVISION

Complete appropriate portion.

Installing contractor shall prepare this form in triplicate and distribute as follows:

White — Send to Dept. of Industry, Labor & Human Relations, Safety & Buildings Division, P.O. Box 7969, Madison, Wisconsin 53707, or City of Milwaukee, if applicable.

Yellow — Send to owner.

Pink — Retain for file.

Description of system

Name of user or owner			Location of installation		
Street Address					
City	State	Zip			
Safety valve settings—power source		Capacity	P S I G		
1.	_____	_____	Maximum allowable pressure	_____	
2.	_____	_____	Test pressure	_____	
3.	_____	_____	Date tested	_____	
Name of installing contractor		Street address	City	State	Zip

I certify this system was installed and tested in accordance with Ind. 41.56 of the Wisconsin Administrative Code.

Date installation completed	Signature of installer	Title	Date registered

INDUSTRY, LABOR AND HUMAN RELATIONS **83**
ILHR 42

State of Wisconsin **W E L D E D R E P A I R** Safety & Buildings Division
 Department of Industry, **R E C O R D** P.O. Box 7969
 Labor and Human Relations Madison, Wisconsin 53707
Telephone: (608) 266-1904

Repair completed on:	Wisconsin Reg. No: _____
<input type="checkbox"/> Power Boiler <input type="checkbox"/> Heating Boiler	National Board No: _____
<input type="checkbox"/> Pressure Vessel <input type="checkbox"/> Miniature Boiler	Serial No: _____
Manufacturer: _____	Other No: _____

WORK COMPLETED BY:	IN THE PLANT OF:
Name: _____	Owner's Name: _____
Street Address _____	Location of Repair: _____
City/Town/Village: _____ Zip Code: _____	_____
Repair Program No: _____	_____

Description of Repair - attach additional page if needed:
 (use reverse side of this page for sketch)

Hydrostatic Test PSI _____ NDE _____
 Repair made in accordance with the requirements of the Wisconsin Department of Industry,
 Labor and Human Relations, Wisconsin Administrative Code Chapters 41-42.

The welding was completed by _____, who has met the test requirements of Chapters 41-42.

Welding procedure specification: _____

Contractor rep. signature: _____ Dated: _____

I, the undersigned, have inspected the work described in this report and state that this work, to the best of my knowledge and belief, has been done in accordance with the requirements of Wis. Adm. Code Chapters ILHR 41-42. By signing this certificate, neither the inspector nor his employer makes any warranty, expressed or implied, concerning the work described in this report. Furthermore, neither the inspector nor his/her employer shall be liable in any manner for any personal injury or property damage or a loss of any kind arising from or connected with this inspection. The only exception is for such liability that may be provided in an insurance policy which the inspector's insurance company may issue for the object, and then only in accordance with terms of that policy.

Authorized Inspector Signature: _____	Cert. No: _____	Employed By: _____	Dated: _____
---------------------------------------	-----------------	--------------------	--------------

SB-190(R,01/87)

FORM R-1, REPORT OF WELDED REPAIR OR ALTERATION as required by the provisions of the National Board Inspection Code

1. Work performed by (name of repair or alteration organization) (P.O. no., job no., etc.) (address)
2. Owner (name) (address)
3. Location of installation (name) (address)
4. Unit identification: (boiler, pressure vessel) Name of original manufacturer
5. Identifying nos.: (mfr's serial no.) (original National Board no.) (jurisdiction no.) (other) (year built)
6. Description of work: (use back, separate sheet, or sketch if necessary)
7. Remarks: Attached are Manufacturers' Partial Data Reports properly identified and signed by Authorized Inspectors for the following items of this report:
Pressure test, if applied ___ psi

CERTIFICATE OF COMPLIANCE
The undersigned certifies that the statements made in this report are correct and that all design, material, construction, and workmanship on this (repair or alteration) conform to the National Board Inspection Code.
Certificate of Authorization no. to use the symbol expires 19
Date 19 Signed (authorized representative)
CERTIFICATE OF INSPECTION
The undersigned, holding a valid Commission issued by The National Board of Boiler and Pressure Vessel Inspectors and certificate of competency issued by the state or province of and employed by of has inspected the work described in this data report on 19 and state that to the best of my knowledge and belief this work has been done in accordance with the National Board Inspection Code.
By signing this certificate, neither the undersigned nor my employer makes any warranty, expressed or implied, concerning the work described in this report. Furthermore, neither the undersigned nor my employer shall be liable in any manner for any personal injury, property damage or loss of any kind arising from or connected with this inspection, except such liability as may be provided in a policy of insurance which the undersigned's insurance company may issue upon said object and then only in accordance with the terms of said policy.
Date 19 Signed (Authorized Inspector) Commissions (National Board (incl. endorsements), state, prov., and no.)

This form may be obtained from The National Board of Boiler and Pressure Vessel Inspectors, 1055 Crupper Ave., Columbus, OH 43229 NB-66 Rev. 4

FORM NR-1 REPORT OF REPAIR MODIFICATION OR INSTALLATION OF REPLACEMENT(S)
TO NUCLEAR COMPONENTS AND SYSTEMS IN NUCLEAR POWER PLANTS

1. Work performed by _____ (name) _____ (repair organization's P.O. no., job no., etc.)
_____ (address)

2. Owner _____ (name) _____
_____ (address)

3. Name, address and identification of nuclear power plant _____

4. Identification of system _____

5. a. Identification of component repaired, modified or replaced _____
b. Name of manufacturer _____
c. Identifying nos. _____ (infr.'s serial no.) _____ (Nat'l. Bd. no.) _____ (jurisdictional no.) _____ (other) _____ (year built)

6. Applicable section(s) _____ of ASME Code, 19 _____ edition _____ addenda _____ Code Case _____

7. Design responsibilities _____

8. Tests conducted: hydrostatic pneumatic design pressure pressure _____ psi.

9. Description of work _____
(use of additional sheet(s) or sketch(es) is acceptable if properly identified)

10. Remarks: _____

CERTIFICATE OF COMPLIANCE

We certify that the statements made in this report are correct and that all design, material and workmanship on this _____ (repair, modification or replacement) conforms to the applicable section of the ASME Code.
Certificate of Authorization no. _____ to use the "NR" stamp expires _____ 19 _____.

Signed _____ (repair organization) _____ (authorized representative) _____ (title) _____ (date) _____ 19 _____

CERTIFICATE OF INSPECTION

I, the undersigned, holding a valid commission issued by The National Board of Boiler and Pressure Vessel Inspectors, and certificate of competency issued by the state or province of _____ and employed by _____ of _____, have inspected the repair, modification or replacement described in this report on _____, 19 _____ and state that to the best of my knowledge and belief, this repair, modification or replacement has been made or constructed in accordance with Section XI and Section III of the ASME Code and the National Board rules as defined in the publications NB-55 and NB-102, current editions. By signing this certificate, neither the Inspector nor his employer makes any warranty, expressed or implied, concerning the repair, modification or replacement described in this report. Furthermore, neither the Inspector nor his employer shall be liable in any manner for any personal injury or property damage or a loss of any kind arising from or connected with this inspection.

Date _____, 19 _____ Signed _____ (Authorized Inspector) _____ Commissions _____ (Nat'l. Bd. no. (including endorsements) state or province and number)

This form may be obtained from The National Board of Boiler and Pressure Vessel Inspectors, 1055 Crupper Ave., Columbus, OH 43229
NB-51
Rev. 4

APPENDIX B

(EXCERPTS FROM BOILER, PRESSURE VESSEL AND
PIPING CODES AND STANDARDS)

Excerpts from the following boiler, pressure vessel and piping codes and standards are reproduced here strictly for reference: ASME Sections I, IV and VIII and ANSI/ASME B31.1. This information has been included to provide a general idea as to the requirements of these codes and standards. Users of this information must be cautioned that these excerpts do not provide complete guidelines for inspection, installation, operation and manufacturing.

Only portions of each code and standard thought to be frequently used by persons not having direct access to the complete documents have been included. It must be noted that these codes and standards change on a periodic basis as indicated in s. ILHR 41.10. Those who are bound by the rules of ch. ILHR 41 must avail themselves of the applicable code section or standards listed in s. ILHR 41.10. Refer to ch. ILHR 42 for rules applying to repairs, alterations, and miscellaneous requirements.

Next page is numbered 91.

APPENDIX

(EXCERPTS FROM BOILER, PRESSURE VESSEL AND PIPING CODES AND STANDARDS)

Excerpts from the following boiler, pressure vessel and piping codes and standards are reproduced here strictly for reference: ASME Sections I, IV and VIII and ANSI/ASME B31.1. This information has been included to provide a general idea as to the requirements of these codes and standards. Users of this information must be cautioned that these excerpts do not provide complete guidelines for inspection, installation, operation and manufacturing.

Only portions of each code and standard thought to be frequently used by persons not having direct access to the complete documents have been included. It must be noted that these codes and standards change on a periodic basis (see s. ILHR 41.10). Those who are bound by the rules of ch. ILHR 41 must avail themselves of the applicable code section or standards listed in s. ILHR 41.10. Refer to ch. ILHR 42 for rules applying to repairs, alterations, and miscellaneous requirements.

EXERPTS FROM:

ASME BOILER AND PRESSURE VESSEL CODE

SECTION I

POWER BOILERS

1980 EDITION

Register, February, 1984, No. 338
Boiler and Pressure Vessel Code

PREAMBLE

This Code covers rules for construction of power boilers,¹ electric boilers,² miniature boilers³ and high-temperature water boilers⁴ to be used in stationary service and includes those power boilers used in locomotive, portable, and traction service. Reference to a paragraph includes all the subparagraphs and subdivisions under that paragraph.

The Code does not contain rules to cover all details of design and construction. Where complete details are not given, it is intended that the manufacturer, subject to the approval of the Authorized Inspector, shall provide details of design and construction which will be as safe as otherwise provided by the rules in the Code.

The scope of jurisdiction of Section I applies to the boiler proper and to the boiler external piping.

Superheaters, economizers, and other pressure parts connected directly to the boiler without intervening valves shall be considered as parts of the boiler proper, and their construction shall conform to Section I rules.

Boiler external piping shall be considered as that piping which begins where the boiler proper terminates at:

(a) the first circumferential joint for welding end connections; or

(b) the face of the first flange in bolted flanged connections; or

(c) the first threaded joint in that type of connection; and which extends up to and including the valve or valves required by this Code.

ASME Code Certification (including Data Forms and Code Symbol Stamping), and/or inspection by the Authorized Inspector, when required by this Code, is required for the boiler proper and the boiler external piping.

Construction rules for materials, design, fabrication, installation, and testing of the boiler external piping are contained in ANSI B31.1—Power Piping. Piping beyond the

valve or valves required by Section I is not within the scope of Section I, and it is not the intent that the Code Symbol Stamp be applied to such piping or any other piping.

The material for forced-circulation boilers, boilers with no fixed steam and water line, and high-temperature water boilers shall conform to the requirements of the Code. All other requirements shall also be met except where they relate to special features of construction made necessary in boilers of these types, and to accessories that are manifestly not needed or used in connection with such boilers, such as water gages, water columns, and gage cocks.

Reheaters receiving steam which has passed through part of a turbine or other prime mover and separately fired steam superheaters which are not integral with the boiler are considered fired pressure vessels and their construction shall comply with Code requirements for superheaters, including safety devices. Piping between the reheater connections and the turbine or other prime mover is not within the scope of the Code.

A pressure vessel in which steam is generated by the application of heat resulting from the combustion of fuel (solid, liquid, or gaseous) shall be classed as a fired steam boiler.

Unfired pressure vessels in which steam is generated shall be classed as unfired steam boilers with the following exceptions:

(a) Vessels known as evaporators or heat exchangers.

(b) Vessels in which steam is generated by the use of heat resulting from operation of a processing system containing a number of pressure vessels such as used in the manufacture of chemical and petroleum products.

Unfired steam boilers shall be constructed under the provisions of Section I or Section VIII.

Expansion tanks required in connection with high-temperature water boilers shall be constructed to the requirements of Section I or Section VIII.

A pressure vessel in which an organic fluid is vaporized by the application of heat resulting from the combustion of fuel (solid, liquid, or gaseous) shall be constructed under the provisions of Section I. Vessels in which vapor is generated incidental to the operation of a processing system, containing a number of pressure vessels such as used in chemical and petroleum manufacture, are not covered by the rules of Section I.

¹Power boiler—a boiler in which steam or other vapor is generated at a pressure of more than 15 psi (100 kPa).

²Electric boiler—a power boiler or a high-temperature water boiler in which the source of heat is electricity.

³Miniature boiler—a power boiler or a high-temperature water boiler in which the limits specified in PMB-2 are not exceeded.

⁴High-temperature water boiler—a water boiler intended for operation at pressures in excess of 160 psi (1100 kPa) and/or temperatures in excess of 250°F (121°C).

PART PG
GENERAL REQUIREMENTS FOR ALL
METHODS OF CONSTRUCTION

GENERAL

PG-1 SCOPE

The requirements of Part PG apply to power boilers and high pressure, high-temperature water boilers and to parts and appurtenances thereto and shall be used in conjunction with the specific requirements in the applicable parts of this Section that pertain to the methods of construction used.

PG-2 SERVICE LIMITATIONS

2.1 The rules of this Section are applicable to the following services:

- (a) boilers in which steam or other vapor is generated at a pressure of more than 15 psig (103 kPa gage);
- (b) high-temperature water boilers intended for operation at pressures exceeding 160 psig (1100 kPa gage) and/or temperatures exceeding 250°F (121°C).

2.2 For services below those specified in PG-2.1 it is intended that rules of Section IV apply; however, boilers for such services may be constructed and stamped in accordance with this Section provided all applicable requirements are met.

2.3 It is not the intent of these rules to cover coil-type hot water boilers without any steam space where water flashes into steam when released through a manually operated nozzle for cleaning machinery, equipment, buildings, etc., unless one of the following limitations is exceeded:

- (a) $\frac{3}{4}$ in. (19 mm) diameter tubing or pipe size with no drums or headers attached;
- (b) nominal water containing capacity not exceeding 6 gal (23 l);
- (c) water temperature not exceeding 350°F (177°C);
- (d) steam not generated within the coil.

Steam cleaners exempt by this classification shall be provided with adequate safety relief valves and controls.

BOILER EXTERNAL PIPING
AND BOILER PROPER
CONNECTIONS

PG-58 OUTLETS AND EXTERNAL
PIPING

58.1 General. The rules of this subparagraph apply to the boiler external piping as defined in the Preamble.

58.2 Boiler External Piping Connections to Boilers. All boiler external piping connected to a boiler for any purpose shall be attached to one of the types of joints listed in PG-59.1.1.1, PG-59.1.1.2, and PG-59.1.1.3.

58.3 Boiler External Piping. The following defines the Code Jurisdictional Limits of the boiler external piping systems, including general requirements, valves, and inspection. The limits are also shown in Fig. PG-58.3.1 and Fig. PG-58.3.2. The materials, design, fabrication, installation, and testing shall be in accordance with ANSI B31.1-1977, Power Piping, including Addenda through the Summer 1979 Addenda and including the applicable B31.1 Code Cases.

58.3.1 The steam piping connected to the boiler drum or to the superheater outlet header shall extend up to and including the first stop valve in each connection, except as required by PG-58.3.2. In the case of a single boiler and prime mover installation, the stop valve required herein may be omitted provided the prime mover throttle valve is equipped with an indicator to show whether the valve is open or closed and is designed to withstand the required hydrostatic pressure test of the boiler.

58.3.2 When two or more boilers are connected to a common steam header, the connection from each boiler having a manhole opening shall be fitted with two stop valves having an ample free-blow drain between them. The boiler external piping includes all piping from the boiler proper up to and including the second stop valve and the free-blow drain valve.

Fig. PG-58.3.1

SECTION I — POWER BOILERS

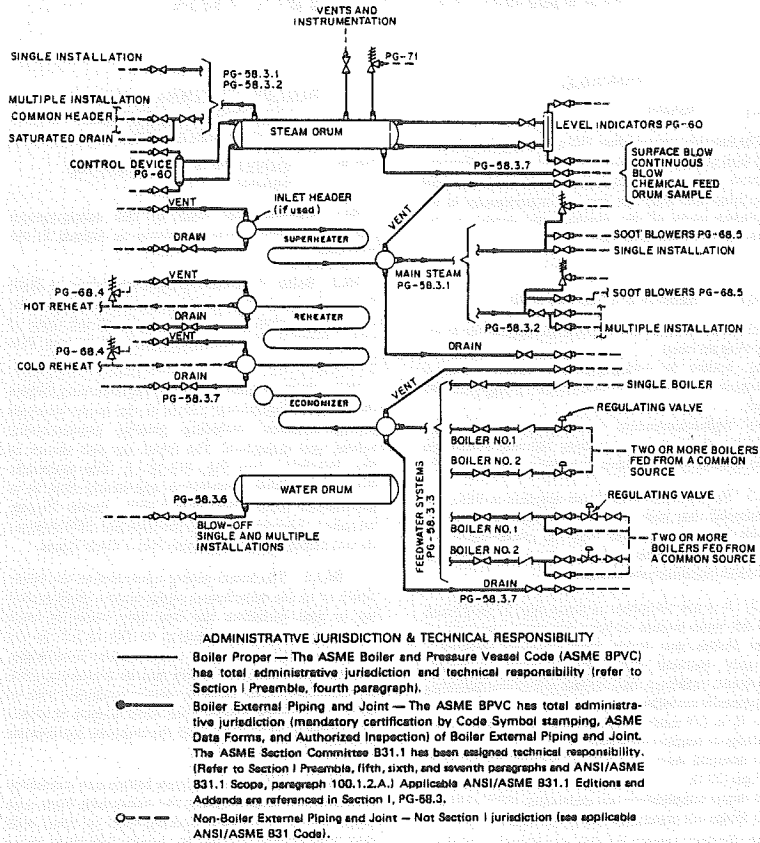
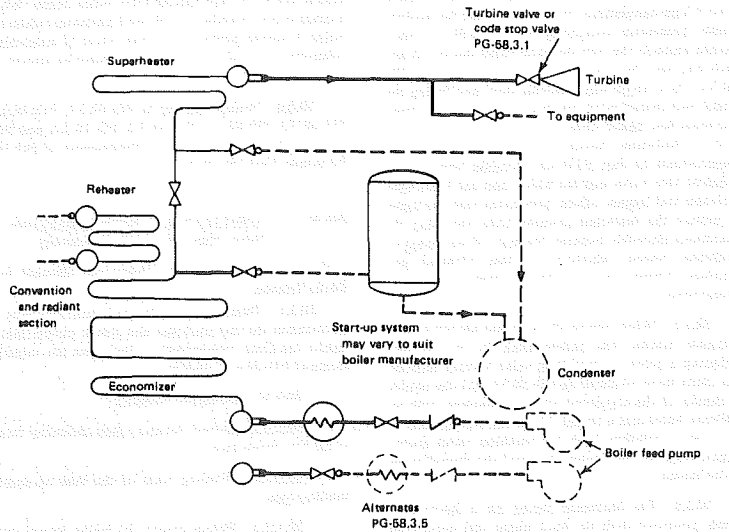

FIG. PG-58.3.1 CODE JURISDICTIONAL LIMITS FOR PIPING — DRUM TYPE BOILERS



ADMINISTRATIVE JURISDICTION & TECHNICAL RESPONSIBILITY

- Boiler Proper — The ASME Boiler and Pressure Vessel Code (ASME BPVC) has total administrative jurisdiction and technical responsibility (refer to Section I Preamble, fourth paragraph).
- — Boiler External Piping and Joint — The ASME BPVC has total administrative jurisdiction (mandatory certification by Code Symbol stamping, ASME Data Forms, and Authorized Inspection) of Boiler External Piping and Joint. The ASME Section Committee B31.1 has been assigned technical responsibility. (Refer to Section I Preamble, fifth, sixth, and seventh paragraphs and ANSI/ASME B31.1 Scope, paragraph 100.1.2.A.) Applicable ANSI/ASME B31.1 Editions and Addenda are referenced in Section I, PG-58.3.
- - - - Non-Boiler External Piping and Joint — Not Section I jurisdiction (see applicable ANSI/ASME B31 Code).

FIG. PG-58.3.2 CODE JURISDICTIONAL LIMITS FOR PIPING — FORCED-FLOW STEAM GENERATOR WITH NO FIXED STEAM AND WATER LINE

58.3.3 The feedwater piping for all boilers, except high-temperature water boilers and forced-flow steam generators complying with PG-58.3.5, shall extend through the required stop valve and up to and including the check valve except as required by PG-58.3.4. On a single boiler-turbine unit installation the boiler feed shutoff valve may be located upstream from the boiler feed check valve.

If a feedwater heater or heaters meeting the requirements of Part PFH are installed between the required stop valve and the boiler, and are fitted with isolation and bypass valves, provisions must be made to prevent the feedwater pressure from exceeding the maximum allowable working pressure of the piping or feedwater heater, whichever is less. Control and interlock systems are permitted in order to prevent overpressure.

58.3.4 When two or more boilers are fed from a common source, the piping shall be up to and including a globe or regulating valve located between the check valve required in PG-58.3.3 and the source of supply. If the regulating valve is equipped with an isolation valve and a bypass valve, the piping shall be up to and including both the isolation valve downstream from the regulating valve and the shutoff valve in the bypass.

58.3.5 The feedwater piping for a forced-flow steam generator with no fixed steam and water line may terminate up to and including the stop valve near the boiler and omitting the check valve near the boiler, provided that a check valve having a pressure rating no less than the boiler inlet design pressure is installed at the discharge of the boiler feed pump or elsewhere in the feedline between the feed pump and the feed stop valve. If the feedwater heater(s) is fitted with isolation and bypass valves, the applicable requirements of PG-58.3.3 must be met.

58.3.6 The blowoff piping for all boilers, except forced-flow steam generators with no fixed steam and waterline, high-temperature water boilers, and those used for traction and/or portable purposes, when the allowable working pressure exceeds 100 psi (690 kPa) shall extend through and including the second valve. The blowoff piping for all traction and/or portable boilers and for forced circulation and electric boilers having a normal water content not exceeding 100 gal (380 l) are required to extend through only one valve.

58.3.7 The miscellaneous piping shall include the piping for such items as drains, vents, surface-blowoff, steam and water piping for water columns, gage glasses and pressure gages, and the recirculation

return line for a high-temperature water boiler. When a drain is not intended for blowoff purposes (when the boiler is under pressure) a single valve is acceptable, otherwise two valves in series are required except as permitted by PG-58.3.6.

58.3.8 Welded piping in PG-58.3.1, PG-58.3.2, PG-58.3.3, PG-58.3.4, PG-58.3.5, PG-58.3.6, and PG-58.3.7 is also subject to the requirements of PG-104 for proper Code certification.

PG-59 APPLICATION REQUIREMENTS FOR THE BOILER PROPER

59.1 Common to Steam, Feedwater, Blowoff, and Drain Systems

59.1.1 Outlets of a boiler to which piping is to be attached for any purpose, and which piping comes within the Code requirements, shall meet the requirements of PG-39 and shall be:

59.1.1.1 A tapped opening.

59.1.1.2 Bolted flanged joints including those of the Van Stone type.

59.1.1.3 Welding ends of the butt or socket welding type.

59.1.1.4 Piping within the boiler proper may be expanded into grooved holes, seal welded if desired. Blowoff piping of firetube boilers shall be attached by threading into a tapped opening with a threaded fitting or valve at the other end if exposed to products of combustion, or by PG-59.1.1.1 or PG-59.1.1.2 if not so exposed (see PFT-49).

59.1.2 Steam Mains. Provisions shall be made for the expansion and contraction of steam mains connected to boilers, by providing substantial anchorage at suitable points, so that there shall be no undue strain transmitted to the boiler. Steam reservoirs shall be used on steam mains when heavy pulsations of the steam currents cause vibration of the boiler shell plates.

59.1.3 Figure PG-59.1 illustrates a typical form of connection for use on boiler shells for passing through piping such as feed, surface blowoff connections, etc., and which permits the pipes' being threaded in solid from both sides in addition to the reinforcing of the opening of the shell. The pipes shall be attached as provided in PG-59.1.1.

In these and other types of boilers where both internal and external pipes making a continuous

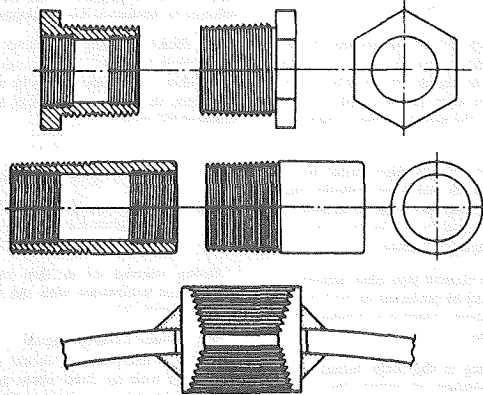

FIG. PG-59.1 TYPICAL BOILER BUSHINGS

passage are employed, the boiler bushing or its equivalent shall be used.

59.2 Requirements for Feedwater Piping. The feedwater shall be introduced into a boiler in such a manner that the water will not be discharged directly against surfaces exposed to gases of high temperature or to direct radiation from the fire. For pressures of 400 psi (2800 kPa) or over, the feedwater inlet through the drum shall be fitted with shields, sleeves, or other suitable means to reduce the effects of temperature differentials in the shell or head. Feedwater, other than condensate returns as provided for in PG-59.3.6, shall not be introduced through the blowoff.

59.3 Requirements for Blowoff Piping

59.3.1 A blowoff as required herein is defined as a pipe connection provided with valves located in the external piping through which the water in the boiler may be blown out under pressure, excepting drains such as are used on water columns, gage glasses, or piping to feedwater regulators, etc., used for the purpose of determining the operating condition of such equipment. Piping connections used primarily for continuous operation, such as deconcentrators on continuous blowdown systems, are not classed as

blowoffs but the pipe connections and all fittings up to and including the first shutoff valve shall be equal at least to the pressure requirements for the lowest set pressure of any safety valve on the boiler drum and with the corresponding saturated-steam temperature.

59.3.2 A surface blowoff shall not exceed 2½ in. pipe size, and the internal pipe and the terminal connection for the external pipe, when used, shall form a continuous passage, but with clearance between their ends and arranged so that the removal of either will not disturb the other. A properly designed steel bushing, similar to or the equivalent of those shown in Fig. PG-59.1, or a flanged connection shall be used.

59.3.3 Each boiler except forced-flow steam generators with no fixed steam and waterline and high-temperature water boilers shall have a bottom blowoff outlet in direct connection with the lowest water space practicable for external piping conforming to PG-58.3.6.

59.3.4 All water walls and water screens which do not drain back into the boiler, and all integral economizers, shall be equipped with outlet connec-

ILHR 42

PG-59.3.4-PG-60.1.1

SECTION I — POWER BOILERS

tions for a blowoff or drain line and conform to the requirements of PG-58.3.6 or PG-58.3.7.

59.3.5 Except as permitted for miniature boilers in Part PMB, the minimum size of pipe and fittings shall be 1 in., and the maximum size shall be 2½ in., except that for boilers with 100 sq ft (9.3 m²) of heating surface or less, the minimum size of pipe and fittings may be ¾ in.

59.3.6 Condensate return connections of the same size or larger than the size herein specified may be used, and the blowoff may be connected to them. In such case the blowoff shall be so located that the connection may be completely drained.

59.3.7 A bottom blowoff pipe when exposed to direct furnace heat shall be protected by firebrick or other heat resisting material which is so arranged that the pipe may be inspected.

59.3.8 An opening in the boiler setting for a blowoff pipe shall be arranged to provide free expansion and contraction.

59.4 Drains

59.4.1 Ample drains shall be provided where required to permit complete drainage of all piping, superheaters, waterwalls, water screens, integral economizers, high-temperature water boilers, and all other boiler components in which water may collect. Piping shall conform to the requirements of PG-58.3.6 or PG-58.3.7.

59.4.1.1 Each superheater shall be equipped with at least one drain so located as to most effectively provide for the proper operation of the apparatus.

59.4.1.2 Each high-temperature water boiler shall have a 1 in. minimum pipe size bottom drain connection in direct connection with the lowest water space practical for external piping conforming to PG-58.3.7.

59.5 Requirements for Valves and Fittings. The following requirements apply to the use of valves and fittings in the boiler proper.

59.5.1 Steam Stop Valves

59.5.1.1 If a shutoff valve is used between the boiler and its superheater, the safety valve capacity on the boiler shall comply with the requirements of PG-67.2 and PG-70, except as provided for in PG-59.5.1.2, no credit being taken for the safety valve on the superheater, and the superheater must be equipped with safety valve capacity as required by PG-68. A

stop valve is not required at the inlet or the outlet of a reheater or separately fired superheater.

59.5.1.2 When stop valves are installed in the water-steam flow path between any two sections of a forced-flow steam generator with no fixed steam and waterline, the safety valves shall satisfy the requirements of PG-67.4.4.

DESIGN AND APPLICATION

PG-60 REQUIREMENTS FOR MISCELLANEOUS PIPE, VALVES, AND FITTINGS

Piping referred to in this paragraph shall be designed in accordance with the applicable requirements of ANSI B31.1.

60.1 Water Level Indicators

60.1.1 Each boiler, except forced-flow steam generators with no fixed steam and waterline, and high-temperature water boilers of the forced circulation type that have no steam and waterline, shall have at least one water gage glass. Boilers operated at pressures over 400 psi (2800 kPa) shall be provided with two water gage glasses which may be connected to a single water column or connected directly to the drum.

Two independent remote level indicators may be used instead of one of the two required gage glasses for boiler drum water level indication in the case of power boilers with all drum safety valves set at or above 900 psi (6200 kPa). When both remote level indicators are in reliable operation, the gage glass may be shut off but shall be maintained in serviceable condition.

When the direct reading of gage glass water level is not readily visible to the operator in his working area, two dependable indirect indications shall be provided, either by transmission of the gage glass image or by remote level indicators.

The lowest visible part of the water gage glass shall be at least 2 in. (51 mm) above the lowest permissible water level, at which level there will be no danger of overheating any part of the boiler when in operation at that level. When remote level indication is provided for the operator in lieu of the gage glass, the same minimum level reference shall be clearly marked.

Connections from the boiler to the remote level indicator shall be at least ¾ in. pipe size to and including the isolation valve and from there to the remote level indicator at least ½ in. (13 mm) O.D. tubing. These connections shall be completely independent of other connections for any function other

than water level indication. For pressures of 400 psi (2800 kPa) or over, lower connections to drums shall be provided with shields, sleeves, or other suitable means to reduce temperature differentials in the shells or heads.

60.1.2 Forced-flow steam generators with no fixed steam and water line and the high-temperature water boiler of the forced circulation type require no water gage glass or gage cocks.

60.1.4 Boilers of the horizontal firetube type shall be so set that when the water is at the lowest reading in the water gage glass, there shall be at least 3 in. (76 mm) of water over the highest point of the tubes, flues, or crown sheets.

60.1.5 Boilers of locomotives shall have at least one water glass provided with top and bottom shutoff cocks and lamp, and two gage cocks for boilers 36 in. (910 mm) in diameter and under, and three gage cocks for boilers over 36 in. (910 mm) in diameter.

The lowest gage cock and the lowest reading of water glass shall not be less than 2 in. (51 mm) above the highest point of crown sheet on boilers 36 in. (910 mm) in diameter and under, nor less than 3 in. (76 mm) for boilers over 36 in. (910 mm) in diameter. These are minimum dimensions, and on large locomotives and those operating on steep grades, the height should be increased, if necessary, to compensate for change of water level on descending grades.

The bottom mounting for water glass and for water column if used must extend not less than 1½ in. (38 mm) inside the boiler and beyond any obstacle immediately above it, and the passage therein must be straight and horizontal.

Tubular water glasses must be equipped with a protecting shield.

60.1.6 All connections on the gage glass shall be not less than ½ in. pipe size. Each water-gage glass shall be fitted with a drain cock or valve having an unrestricted drain opening of not less than ¼ in. (6 mm) diameter to facilitate cleaning. When the boiler operating pressure exceeds 100 psi (690 kPa) the glass shall be furnished with a connection to install a valved drain to the ash pit or other safe discharge point.

Each water gage glass shall be equipped with a top and a bottom shutoff valve of such through-flow construction as to prevent stoppage by deposits of sediments. If the lowest valve is more than 7 ft (2.1 m) above the floor or platform from which it is operated, the operating mechanism shall indicate by its position whether the valve is open or closed. The pressure-temperature rating shall be at least equal to that of the

lowest set pressure of any safety valve on the boiler drum and the corresponding saturated-steam temperature.

Straight-run globe valves shall not be used on such connections.

Automatic shutoff valves, if permitted to be used, shall conform to the requirements given in A-18.

60.2 Water Columns

60.2.1 The water column shall be so mounted that it will maintain its correct position relative to the normal waterline under operating conditions.

60.2.2 The minimum size of pipes connecting the water column to a boiler shall be 1 in. For pressures of 400 psi (2800 kPa) or over, lower water column connections to drums shall be provided with shields, sleeves, or other suitable means to reduce the effect of temperature differentials in the shells or heads. Water glass fittings or gage cocks may be connected directly to the boiler.

60.2.3 The steam and water connections to a water column or a water gage glass shall be such that they are readily accessible for internal inspection and cleaning. Some acceptable methods of meeting this requirement are by providing a cross or fitting with a back outlet at each right-angle turn to permit inspection and cleaning in both directions, or by using pipe bends or fittings of a type which does not leave an internal shoulder or pocket in the pipe connection and with a radius of curvature which will permit the passage of a rotary cleaner. Screwed plug closures using threaded connections as allowed by PG-39.5.3 are acceptable means of access for this inspection and cleaning. For boilers with all drum safety valves set at or above 400 psig (2800 kPa), socket-welded plugs may be used for this purpose in lieu of screwed plugs. The water column shall be fitted with a connection for a drain cock or drain valve to install a pipe of at least ¾ in. pipe size to the ash pit or other safe point of discharge. If the water connection to the water column has a rising bend or pocket which cannot be drained by means of the water-column drain, an additional drain shall be placed on this connection in order that it may be blown off to clear any sediment from the pipe.

60.2.4 The design and material of a water column shall comply with the requirements of PG-42. Water column made of cast iron in accordance with SA-278 may be used for maximum boiler pressures not exceeding 250 psi (1700 kPa). Water columns made of ductile iron in accordance with SA-395 may be used for maximum boiler pressures not exceeding

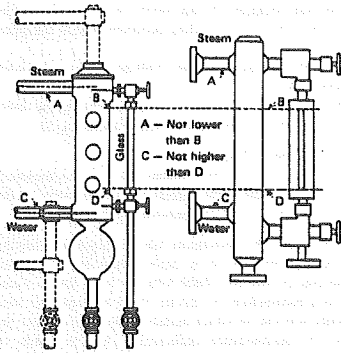

FIG. PG-60 TYPICAL ARRANGEMENT OF STEAM AND WATER CONNECTIONS FOR A WATER COLUMN

350 psi (2400 kPa). For higher pressures, steel construction shall be used.

60.2.5 Shutoff valves shall not be used in the pipe connections between a boiler and a water column or between a boiler and the shutoff valves required for the gage glass (PG-60.1.6), unless they are either outside-screw-and-yoke or level-lifting type gate valves or stopcocks with lever permanently fastened thereto and marked in line with their passage, or of such other through-flow construction as to prevent stoppage by deposits of sediment, and to indicate by the position of the operating mechanism whether they are in open or closed position; and such valves or cocks shall be locked or sealed open. Where stop cocks are used they shall be of a type with the plug held in place by a guard or gland.

60.2.6 No outlet connections, except for damper regulator, feedwater regulator, drains, steam gages, or apparatus of such form as does not permit the escape of an appreciable amount of steam or water therefrom shall be placed on the pipes connecting a water column or gage glass to a boiler.

60.3 Gage Glass Connections

60.3.1 Gage glasses and gage cocks that are required by PG-60.1 and PG-60.4 and are not

connected directly to a shell or drum of the boiler, shall be connected by one of the following methods:

60.3.1.1 The water gage glass or glasses and gage cocks shall be connected to an intervening water column.

60.3.1.2 When only water gage glasses are used, they may be mounted away from the shell or drum and the water column omitted, provided the following requirements are met:

60.3.1.2.1 The top and bottom gage glass fittings are aligned, supported, and secured so as to maintain the alignment of the gage glass; and

60.3.1.2.2 The steam and water connections are not less than 1 in. pipe size and each water glass is provided with a valved drain; and

60.3.1.2.3 The steam and water connections comply with the requirements of the following PG-60.3.2 and PG-60.3.3.

60.3.2 The lower edge of the steam connection to a water column or gage glass in the boiler shall not be below the highest visible water level in the water gage glass. There shall be no sag or offset in the piping which will permit the accumulation of water.

60.3.3 The upper edge of the water connection to a water column or gage glass and the boiler shall not be above the lowest visible water level in the gage glass. No part of this pipe connection shall be above the point of connection at the water column.

60.3.4 An acceptable arrangement is shown in Fig. PG-60.

60.4 Gage Cocks. Each boiler (except those not requiring water level indicators per PG-60.1.2) shall have three or more gage cocks located within the visible length of the water glass, except when the boiler has two water glasses located on the same horizontal lines.

Boilers not over 36 in. (910 mm) in diameter in which the heating surface does not exceed 100 sq ft (9.3 m²) need have but two gage cocks.

The gage cock connections shall be not less than $\frac{1}{2}$ in. pipe size.

60.5 Water Frosts. Each boiler fitted with a water jacketed boiler-furnace mouth protector, or similar appliance having valves on the pipes connecting them to the boiler shall have these valves locked or sealed open. Such valves, when used, shall be of the straight-way type.

DEPT. OF INDUSTRY, LABOR & HUMAN RELATIONS 101
ILHR 42

GENERAL REQUIREMENTS

PG-60.6-PG-61.5

60.6 Pressure Gages

60.6.1 Each boiler shall have a pressure gage so located that it is easily readable. The pressure gage shall be installed so that it shall at all times indicate the pressure in the boiler. Each steam boiler shall have the pressure gage connected to the steam space or to the water column or its steam connection. A valve or cock shall be placed in the gage connection adjacent to the gage. An additional valve or cock may be located near the boiler providing it is locked or sealed in the open position. No other shutoff valves shall be located between the gage and the boiler. The pipe connection shall be of ample size and arranged so that it may be cleared by blowing out. For a steam boiler the gage or connection shall contain a syphon or equivalent device which will develop and maintain a water seal that will prevent steam from entering the gage tube. Pressure gage connections shall be suitable for the maximum allowable working pressure and temperature, but if the temperature exceeds 406°F (208°C), brass or copper pipe or tubing shall not be used. The connections to the boiler, except the syphon, if used, shall not be less than ¼ in. standard pipe size but where steel or wrought iron pipe or tubing is used, they shall not be less than ½ in. (13 mm) inside diameter. The minimum size of a syphon, if used, shall be ¼ in. (6 mm) inside diameter. The dial of the pressure gage shall be graduated to approximately double the pressure at which the safety valve is set, but in no case to less than 1½ times this pressure.

60.6.2 Each forced-flow steam generator with no fixed steam and water line shall be equipped with pressure gages or other pressure measuring devices located as follows:

60.6.2.1 At the boiler or superheater outlet (following the last section which involves absorption of heat); and

60.6.2.2 At the boiler or economizer inlet (preceding any section which involves absorption of heat); and

60.6.2.3 Upstream of any shutoff valve which may be used between any two sections of the heat absorbing surface.

60.6.3 Each boiler shall be provided with a valve connection at least ¼ in. pipe size for the exclusive purpose of attaching a test gage when the boiler is in service, so that the accuracy of the boiler pressure gage can be ascertained.

60.6.4 Each high-temperature water boiler shall have a temperature gage so located and connected that

it shall be easily readable. The temperature gage shall be installed so that it at all times indicates the temperature in degrees Fahrenheit of the water in the boiler, at or near the outlet connection.

PG-61 FEEDWATER SUPPLY

61.1 Except as provided for in PG-61.2 and PG-61.4, boilers having more than 500 sq ft (47 m²) of water-heating surface shall have at least two means of feeding water. Except as provided for in PG-61.3, PG-61.4, and PG-61.5, each source of feeding shall be capable of supplying water to the boiler at a pressure of 3% higher than the highest setting of any safety valve on the boiler. For boilers that are fired with solid fuel not in suspension, and for boilers whose setting or heat source can continue to supply sufficient heat to cause damage to the boiler if the feed supply is interrupted, one such means of feeding shall be steam operated.

61.2 Except as provided for in PG-61.1, a boiler fired by gaseous, liquid, or solid fuel in suspension may be equipped with a single means of feeding water provided means are furnished for the shutting off of its heat input prior to the water level reaching the lowest permissible level established by PG-60.

61.3 For boilers having a water-heating surface of not more than 100 sq ft (9.3 m²) the feed connection to the boiler shall not be smaller than ½ in. pipe size. For boilers having a water-heating surface more than 100 sq ft (9.3 m²) the feed connection to the boiler shall not be less than ¾ in. pipe size.

61.4 High-temperature water boilers shall be provided with means of adding water to the boiler or system while under pressure.

61.5 A forced-flow steam generator with no fixed steam and water line shall be provided with a source of feeding capable of supplying water to the boiler at a pressure not less than the expected maximum sustained pressure at the boiler inlet, as determined by the boiler Manufacturer, corresponding to operation at maximum designed steaming capacity with maximum allowable working pressure at the superheater outlet.

**SAFETY VALVES AND SAFETY
RELIEF VALVES¹⁷**

**PG-67 BOILER SAFETY VALVE
REQUIREMENTS**

67.1 Each boiler shall have at least one safety valve or safety relief valve and if it has more than 500 sq ft (47 m²) of water-heating surface, or if an electric boiler has a power input more than 500 kW, it shall have two or more safety valves or safety relief valves. The method of computing the steam-generating capacity of the boiler shall be as given in A-12. Organic fluid vaporizer generators require special consideration as given in Part PVG.

67.2 The safety valve or safety relief valve capacity for each boiler (except as noted in PG-67.4) shall be such that the safety valve, or valves will discharge all the steam that can be generated by the boiler without allowing the pressure to rise more than 6% above the highest pressure at which any valve is set and in no case to more than 6% above the maximum allowable working pressure. The safety valve or safety relief valve capacity shall be in compliance with PG-70 but shall not be less than the maximum designed steaming capacity as determined by the Manufacturer. The required steam relieving capacity, in lb/hr (kg/hr), of the safety relief valves on a high-temperature water boiler shall be determined by dividing the maximum output in Btu/hr (kJ/hr) at the boiler nozzle obtained by the firing of any fuel for which the unit is designed by 1000.

Any economizer which may be shut off from the boiler, thereby permitting the economizer to become a fired pressure vessel, shall have one or more safety relief valves with a total discharge capacity, calculated from the maximum expected heat absorption in Btu/hr (kJ/hr), as determined by the Manufacturer, divided by 1000. This absorption shall be stated in the stamping (PG-106.4).

The required relieving capacity in pounds per hour of the safety or safety relief valves on a waste heat boiler shall be determined by the Manufacturer. When auxiliary firing is to be used in combination with waste heat recovery, the maximum output shall include the effect of such firing in the total required capacity.

¹⁷Safety Valve: An automatic pressure relieving device actuated by the static pressure upstream of the valve and characterized by full-opening pop action. It is used for gas or vapor service.

Relief Valve: An automatic pressure relieving device actuated by the static pressure upstream of the valve which opens further with the increase in pressure over the opening pressure. It is used primarily for liquid service.

Safety Relief Valve: An automatic pressure-actuated relieving device suitable for use either as a safety valve or relief valve, depending on application.

When auxiliary firing is to be used in place of waste heat recovery, the required relieving capacity shall be based on auxiliary firing or waste heat recovery, whichever is higher.

67.3 One or more safety valves on the boiler proper shall be set at or below the maximum allowable working pressure (except as noted in PG-67.4). If additional valves are used the highest pressure setting shall not exceed the maximum allowable working pressure by more than 3%. The complete range of pressure settings of all the saturated-steam safety valves on a boiler shall not exceed 10% of the highest pressure to which any valve is set. Pressure setting of safety relief valves on high-temperature water boilers¹⁸ may exceed this 10% range.

67.4 For a forced-flow steam generator with no fixed steam and waterline, equipped with automatic controls and protective interlocks responsive to steam pressure, safety valves may be provided in accordance with the above paragraphs or the following protection against overpressure shall be provided:

67.4.1 One or more power-actuated pressure relieving valves¹⁹ shall be provided in direct communication with the boiler when the boiler is under pressure and shall receive a control impulse to open when the maximum allowable working pressure at the superheater outlet, as shown in the master stamping (PG-106.3), is exceeded. The total combined relieving capacity of the power-actuated relieving valves shall be not less than 10% of the maximum design steaming capacity of the boiler under any operating condition as determined by the Manufacturer. The valve or valves shall be located in the pressure part system where they will relieve the overpressure.

An isolating stop valve of the outside-screw-and-yoke type may be installed between the power-actuated pressure relieving valve and the boiler to permit repairs provided an alternate power-actuated pressure

¹⁸Safety relief valves in hot water service are more susceptible to damage and subsequent leakage, than safety valves relieving steam. It is recommended that the maximum allowable working pressure of the boiler and the safety relief valve setting for high-temperature water boilers be selected substantially higher than the desired operating pressure so as to minimize the times the safety relief valve must lift.

¹⁹The power-actuated pressure relieving valve is one whose movements to open or close are fully controlled by a source of power (electricity, air, steam, or hydraulic). The valve may discharge to atmosphere or to a container at lower pressure. The discharge capacity may be affected by the downstream conditions, and such effects shall be taken into account. If the power-actuated pressure relieving valves are also positioned in response to other control signals, the control impulse to prevent overpressure shall be responsive only to pressure and shall override any other control function.

DEPT. OF INDUSTRY, LABOR & HUMAN RELATIONS 103
ILHR 42

GENERAL REQUIREMENTS

PG-67.4.1-PG-67.4.4.1

relieving valve of the same capacity is so installed as to be in direct communication with the boiler in accordance with the requirements of this paragraph.

Power-actuated pressure relieving valves discharging to intermediate pressure and incorporated into bypass and/or startup circuits by the boiler Manufacturer need not be capacity certified. Instead, they shall be marked by the valve manufacturer with a capacity rating at a set of specified inlet pressure and temperature conditions. Power-actuated pressure relieving valves discharging directly to atmosphere shall be capacity certified. This capacity certification shall be conducted in accordance with the provisions of PG-69.3. The valves shall be marked in accordance with the provisions of PG-69.4 and PG-69.5.

67.4.2 Spring-loaded safety valves shall be provided, having a total combined relieving capacity, including that of the power-actuated pressure relieving capacity installed under PG-67.4.1, of not less than 100% of the maximum designed steaming capacity of the boiler, as determined by the Manufacturer, except the alternate provisions of PG-67.4.3 are satisfied. In this total, no credit in excess of 30% of the total required relieving capacity shall be allowed for the power-actuated pressure relieving valves actually installed. Any or all of the spring-loaded safety valves may be set above the maximum allowable working pressure of the parts to which they are connected, but the set pressures shall be such that when all of these valves (together with the power-actuated pressure relieving valves) are in operation the pressure will not rise more than 20% above the maximum allowable working pressure of any part of the boiler, except for the steam piping between the boiler and the prime mover.

67.4.3 The total installed capacity of spring-loaded safety valves may be less than the requirements of PG-67.4.2 provided all of the following conditions are met.

67.4.3.1 The boiler shall be of no less steaming capacity than 1,000,000 lb/hr (450 000 kg/hr) and installed in a unit system for power generation (i.e., a single boiler supplying a single turbine-generator unit).

67.4.3.2 The boiler shall be provided with automatic devices, responsive to variations in steam pressure, which include no less than all the following:

67.4.3.2.1 A control capable of maintaining steam pressure at the desired operating level and of modulating firing rates and feedwater flow in proportion to a variable steam output; and

67.4.3.2.2 A control which overrides PG-

67.4.3.2.1 by reducing the fuel rate and feedwater flow when the steam pressure exceeds the maximum allowable working pressure as shown in the master stamping (PG-106.3) by 10%; and

67.4.3.2.3 A direct-acting overpressure-trip-actuating mechanism, using an independent pressure sensing device, that will stop the flow of fuel and feedwater to the boiler, at a pressure higher than the set pressure of PG-67.4.3.2.2, but less than 20% above the maximum allowable working pressure as shown in the master stamping (PG-106.3).

67.4.3.3 There shall be not less than two spring-loaded safety valves and the total rated relieving capacity of the spring-loaded safety valves shall be not less than 10% of the maximum designed steaming capacity of the boiler as determined by the Manufacturer. These spring-loaded safety valves may be set above the maximum allowable working pressure of the parts to which they are connected but shall be set such that the valves will lift at a pressure no higher than 20% above the maximum allowable working pressure as shown in the master stamping (PG-106.3).

67.4.3.4 At least two of these spring-loaded safety valves shall be equipped with a device that directly transmits the valve stem lift action to controls that will stop the flow of fuel and feedwater to the boiler. The control circuitry to accomplish this shall be arranged in a "fail-safe" manner (see Note).

NOTE: "Fail-safe" shall mean a circuitry arranged as either of the following:

(1) *Energize to trip:* There shall be at least two separate and independent trip circuits served by two power sources, to initiate and perform the trip action. One power source shall be a continuously charged dc battery. The second source shall be an ac-to-dc converter connected to the dc system to charge the battery and capable of performing the trip action. The trip circuits shall be continuously monitored for availability.

It is not mandatory to duplicate the mechanism that actually stops the flow of fuel and feedwater.

(2) *De-energize to trip:* If the circuits are arranged in such a way that a continuous supply of power is required to keep the circuits closed and operating and such that any interruption of power supply will actuate the trip mechanism, then a single trip circuit and single power supply will be enough to meet the requirements of this subparagraph.

67.4.3.5 The power supply for all controls and devices required by PG-67.4.3 shall include at least one source contained within the same plant as the boiler and which is arranged to actuate the controls and devices continuously in the event of failure or interruption of any other power sources.

67.4.4 When stop valves are installed in the water-steam flow path between any two sections of a forced-flow steam generator with no fixed steam and water line:

67.4.4.1 The power-actuated pressure relie-

ing valve(s) required by PG-67.4.1 shall also receive a control impulse to open when the maximum allowable working pressure of the component, having the lowest pressure level upstream to the stop valve, is exceeded; and

67.4.4.2 The spring-loaded safety valves shall be located to provide the pressure protection requirements in PG-67.4.2 or PG-67.4.3.

67.4.5 A reliable pressure-recording device shall always be in service and records kept to provide evidence of conformity to the above requirements.

67.5 All safety valves or safety relief valves shall be so constructed that the failure of any part cannot obstruct the free and full discharge of steam and water from the valve. Safety valves shall be of the direct spring-loaded pop type, with seat inclined at any angle between 45 and 90 deg. ($\pi/4$ and $\pi/2$ rad), inclusive, to the center line of the spindle. The coefficient of discharge of safety valves shall be determined by actual steam flow measurements at a pressure not more than 3% above the pressure at which the valve is set to blow and when adjusted for blowdown in accordance with PG-72. The valves shall be credited with capacities as determined by the provisions of PG-69.2.

Safety valves or safety relief valves may be used which give any opening up to the full discharge capacity of the area of the opening of the inlet of the valve (see PG-69.5), provided the movement of the steam safety valve is such as not to induce lifting of water in the boiler.

Deadweight or weighted lever safety valves or safety relief valves shall not be used.

For high-temperature water boilers safety relief valves shall be used. Such valves shall have a closed bonnet. For purposes of selection the capacity rating of such safety relief valves shall be expressed in terms of actual steam flow determined on the same basis as for safety valves. In addition the safety relief valves shall be capable of satisfactory operation when relieving water at the saturation temperature corresponding to the pressure at which the valve is set to blow.

67.6 A safety valve or safety relief valve over 3 in. (76 mm) in size, used for pressures greater than 15 psig (100 kPa gage), shall have a flanged inlet connection or a weld-end inlet connection. The dimensions of flanges subjected to boiler pressure shall conform to the applicable American National Standards as given in PG-42. The facing shall be similar to those illustrated in the Standard.

67.7 Safety valves or safety relief valves may have bronze parts complying with either SB-61 or SB-62,

provided the maximum allowable stresses and temperatures do not exceed the values given in Table PG-23.2 and shall be marked to indicate the class of material used. Such valves shall not be used on superheaters delivering steam at a temperature over 450°F (232°C) and 306°F (152°C) respectively, and shall not be used for high-temperature water boilers.

PG-68 SUPERHEATER SAFETY VALVE REQUIREMENTS

68.1 Every attached superheater shall have one or more safety valves near the outlet. If the superheater outlet header has a full, free, steam passage from end to end and is so constructed that steam is supplied to it at practically equal intervals throughout its length so that there is a uniform flow of steam through the superheater tubes and the header, the safety valve, or valves, may be located anywhere in the length of the header.

68.2 The discharge capacity of the safety valve, or valves, on an attached superheater may be included in determining the number and size of the safety valves for the boiler, provided there are no intervening valves between the superheater safety valve and the boiler, and provided the discharge capacity of the safety valve, or valves, on the boiler, as distinct from the superheater is at least 75% of the aggregate valve capacity required.

68.3 Every independently fired superheater which may be shut off from the boiler and permit the superheater to become a fired pressure vessel shall have one or more safety valves having a discharge capacity equal to 6 lb of steam per square foot (29 kg of steam per m²) of superheater surface measured on the side exposed to the hot gases. The number of safety valves installed shall be such that the total capacity is at least equal to that required.

68.4 Every reheater shall have one or more safety valves, such that the total relieving capacity is at least equal to the maximum steam flow for which the reheater is designed. At least one valve shall be located on the reheater outlet. The relieving capacity of the valve on the reheater outlet shall be not less than 15% of the required total. The capacity of reheater safety valves shall not be included in the required relieving capacity for the boiler and superheater.

68.5 A soot blower connection may be attached to the same outlet from the superheater or reheater that is used for the safety valve connection.

DEPT. OF INDUSTRY, LABOR & HUMAN RELATIONS 105
ILHR 42

SECTION I — POWER BOILERS

68.6 Every safety valve used on a superheater or reheater discharging superheated steam at a temperature over 450°F (232°C) shall have a casing, including the base, body, and bonnet and spindle, of steel, steel alloy, or equivalent heat-resisting material.

The valve shall have a flanged inlet connection, or a weld-end inlet connection. It shall have the seat and disk of suitable heat erosive and corrosive-resisting material, and the spring fully exposed outside of the valve casing so that it shall be protected from contact with the escaping steam.

TABLE PG-70
MINIMUM POUNDS OF STEAM PER HOUR
PER SQUARE FOOT OF SURFACE

	Firetube Boilers	Watertube Boilers
Boiler heating surface		
Hand fired	5	6
Stoker fired	7	8
Oil, gas, or pulverized fuel fired	8	10
Waterwall heating surface		
Hand fired	8	8
Stoker fired	10	12
Oil, gas, or pulverized fuel fired	14	16

NOTE:

When a boiler is fired only by a gas having a heat value not in excess of 200 Btu/cu ft, the minimum safety valve or safety relief valve relieving capacity may be based on the values given for hand-fired boilers above.

The minimum safety valve or safety relief valve relieving capacity for electric boilers shall be 3½ lb (1.6 kg) /hr/kW input.

In many cases a greater relieving capacity of safety valves or safety relief valves will have to be provided than the minimum specified by this rule, and in every case the requirements of PG-67.2 shall be met.

70.2 The heating surface shall be computed as follows.

70.2.1 Heating surface, as part of a circulating system in contact on one side with water or wet steam being heated and on the other side with gas or refractory being cooled, shall be measured on the side receiving heat.

70.2.2 Boiler heating surface and other equivalent surface outside the furnace shall be measured circumferentially plus any extended surface.

70.2.3 Waterwall heating surface and other equivalent surface within the furnace shall be measured as the projected tube area (diameter × length) plus any extended surface on the furnace side. In computing the heating surface for this purpose, only the tubes, fireboxes, shells, tubesheets, and the projected area of headers need be considered, except that for vertical firetube steam boilers, only that portion of the tube surface up to the middle gage cock is to be computed. The minimum number and size of safety valves or safety relief valves required shall be determined on the basis of the aggregate relieving capacity and the relieving capacity marked on the valves by the manufacturer. Where the operating conditions are changed, or additional heating surface such as water screens or waterwalls is connected to the boiler

PG-70 CAPACITY

70.1 The minimum safety valve or safety relief valve relieving capacity for other than electric boilers, waste heat boilers, organic fluid vaporizer generators, and forced-flow steam generators with no fixed steam and water line, when provided in accordance with PG-67.4.3, shall be determined on the basis of the pounds of steam generated per hour per square foot of boiler heating surface and waterwall heating surface, as given in the Table PG-70.

circulation, the safety valve or safety relief valve capacity shall be increased, if necessary, to meet the new conditions and be in accordance with PG-67.2. The additional valves required on account of changed conditions may be installed on the steam or water line between the boiler and the main stop valve except when the boiler is equipped with a superheater or other piece of apparatus, in which case they may be installed on the steam pipes between the boiler drum and the inlet to the superheater or other apparatus, provided that the steam main between the boiler and points where a safety valve or valves may be attached has a cross-sectional area at least three times the combined areas of the inlet connections to the safety valves applied to it.

70.3 If the safety valve or safety relief valve capacity cannot be computed or if it is desirable to prove the computations, it may be checked in any one of the three following ways, and if found insufficient, additional capacity shall be provided.

70.3.1 By making an accumulation test, that is, by shutting off all other steam discharge outlets from the boiler and forcing the fire to the maximum. The safety valve equipment shall be sufficient to prevent an excess pressure beyond that specified in PG-67.2. This method should not be used on a boiler with a superheater or reheater or on a high-temperature water boiler.

70.3.2 By measuring the maximum amount of fuel that can be burned and computing the corresponding evaporative capacity upon the basis of the heating value of the fuel (see A-12 through A-17).

70.3.3 By determining the maximum evaporative capacity by measuring the feedwater. The sum of the safety valve capacities marked on the valves shall be equal to or greater than the maximum evaporative capacity of the boiler. This method shall not be used on high-temperature water boilers.

PG-71 MOUNTING

71.1 When two or more safety valves are used on a boiler, they may be mounted either separately or as twin valves made by placing individual valves on Y-bases, or duplex valves having two valves in the same body casing. Twin valves made by placing individual valves on Y-bases, or duplex valves having two valves in the same body, shall be of approximately equal capacity.

When not more than two valves of different sizes are

mounted singly the relieving capacity of the smaller valve shall be not less than 50% of that of the larger valve.

71.2 The safety valve or safety relief valve or valves shall be connected to the boiler independent of any other connection, and attached as close as possible to the boiler, without any unnecessary intervening pipe or fitting. Such intervening pipe or fitting shall be not longer than the face-to-face dimension of the corresponding tee fitting of the same diameter and pressure under the applicable American National Standard listed in PG-42 and shall also comply with PG-8 and PG-39. Every safety valve or safety relief valve shall be connected so as to stand in an upright position, with spindle vertical. On high-temperature water boilers of the watertube forced-circulation type, the valve shall be located at the boiler outlet.

71.3 The opening or connection between the boiler and the safety valve or safety relief valve shall have at least the area of the valve inlet. No valve of any description shall be placed between the required safety valve or safety relief valve or valves and the boiler, nor on the discharge pipe between the safety valve or safety relief valve and the atmosphere. When a discharge pipe is used, the cross-sectional area shall be not less than the full area of the valve outlet or of the total of the areas of the valve outlets, discharging thereinto. It shall be as short and straight as possible and so arranged as to avoid undue stresses on the valve or valves.

All safety valve or safety relief valve discharges shall be so located or piped as to be carried clear from running boards or platforms. Ample provision for gravity drain shall be made in the discharge pipe at or near each safety valve or safety relief valve, and where water of condensation may collect. Each valve shall have an open gravity drain through the casing below the level of the valve seat. For iron- and steel-bodied valves exceeding 2½ in. size, the drain hole shall be tapped not less than ¼ in. pipe size.

Discharge piping from safety relief valves on high-temperature water boilers shall be provided with adequate provisions for water drainage as well as the steam venting.

The installation of cast iron bodied safety relief valves for high-temperature water boilers is prohibited.

71.4 If a muffler is used on a safety valve or safety relief valve, it shall have sufficient outlet area to prevent back pressure from interfering with the proper operation and discharge capacity of the valve. The

DEPT. OF INDUSTRY, LABOR & HUMAN RELATIONS 107
ILHR 42

GENERAL REQUIREMENTS

PG-71.4-PG-73.1.1

muffler plates or other devices shall be so constructed as to avoid a possibility of restriction of the steam passages due to deposit. Mufflers shall not be used on high-temperature water boiler safety relief valves.

When a safety valve or safety relief valve is exposed to outdoor elements which may affect operation of the valve, it is permissible to shield the valve with a satisfactory cover. The shield or cover shall be properly vented and arranged to permit servicing and normal operation of the valve.

71.5 When a boiler is fitted with two or more safety valves or safety relief valves on one connection, this connection to the boiler shall have a cross-sectional area not less than the combined areas of inlet connections of all the safety valves or safety relief valves with which it connects and shall also meet the requirements of PG-71.3.

71.6 Safety valves may be attached to drums or headers by welding provided the welding is done in accordance with Code requirements.

71.7 Every boiler shall have proper outlet connections for the required safety valve, or safety relief valve, or valves, independent of any other outside steam connection, the area of opening to be at least equal to the aggregate areas of inlet connections of all of the safety valves or safety relief valves to be attached thereto. An internal collecting pipe, splash plate, or pan may be used, provided the total area for inlet of steam thereto is not less than twice the aggregate areas of the inlet connections of the attached safety valves. The holes in such collecting pipes shall be at least $\frac{1}{4}$ in. (6 mm) in diameter and the least dimension in any other form of opening for inlet of steam shall be $\frac{1}{4}$ in. (6 mm).

Such dimensional limitations to operation for steam need not apply to steam scrubbers or driers provided the net free steam inlet area of the scrubber or drier is at least 10 times the total area of the boiler outlets for the safety valves.

71.8 If safety valves are attached to a separate steam drum or dome, the opening between the boiler proper and the steam drum or dome shall be not less than required by PG-71.7.

PG-72 OPERATION

72.1 Safety valves shall be designed and constructed to operate without chattering and to attain full lift at a pressure no greater than 3% above their set pressure. After blowing down, all valves shall close at

a pressure not lower than 96% of their set pressure, except that all drum valves installed on a single boiler may be set to reset at a pressure not lower than 96% of the set pressure of the lowest set drum valve. The minimum blowdown in any case shall be 2 psi (14 kPa). For spring-loaded pop safety valves for pressure between 200 and 300 psi (1400 and 2100 kPa), both inclusive, the blowdown shall not be less than 1% of the set pressure. To insure the guaranteed capacity and satisfactory operation, the blowdown as marked upon the valve (PG-69.5) shall not be reduced.

Safety valves used on forced-flow steam generators with no fixed steam and waterline, and safety relief valves used on high-temperature water boilers may be set and adjusted to close after blowing down not more than 10% of the set pressure. The valves for these special uses must be so adjusted and marked by the manufacturer.

72.2 The popping point tolerance plus or minus shall not exceed the following: 2 psi (14 kPa) for pressures up to and including 70 psi (480 kPa), 3% for pressures over 70 psi (480 kPa) up to and including 300 psi (2100 kPa), 10 psi (69 kPa) for pressures over 300 psi (2100 kPa) up to and including 1000 psi (6900 kPa), and 1% for pressures over 1000 psi (6900 kPa).

72.3 The spring in a safety valve or safety relief valve in service for pressures up to and including 250 psi (1700 kPa) shall not be used for any pressure more than 10% above or 10% below that for which the safety valve or safety relief valve is marked. For higher pressures the spring shall not be reset for any pressure more than 5% above or 5% below that for which the safety valve or safety relief valve is marked.

72.4 If the operating conditions of a valve are changed so as to require a new spring under PG-72.3 for a different pressure, the valve shall be adjusted by the manufacturer or his authorized representative who shall furnish and install a new nameplate as required under PG-110.

GENERAL REQUIREMENTS

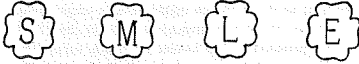

FIG. PG-105.1 OFFICIAL SYMBOLS FOR STAMPS TO DENOTE THE AMERICAN SOCIETY OF MECHANICAL ENGINEERS' STANDARD



FIG. PG-105.2 OFFICIAL SYMBOL FOR STAMP TO DENOTE THE AMERICAN SOCIETY OF MECHANICAL ENGINEERS' STANDARD FOR ASSEMBLY

FIG. PG-105.3 OFFICIAL SYMBOL FOR STAMP TO DENOTE THE AMERICAN SOCIETY OF MECHANICAL ENGINEERS' STANDARD FOR WELDED PIPING



FIG. PG-105.4 OFFICIAL SYMBOL FOR STAMP TO DENOTE THE AMERICAN SOCIETY OF MECHANICAL ENGINEERS' STANDARD

PG-105 CODE SYMBOL STAMPS

105.1 Each boiler, superheater, waterwall, and steel economizer to which a Code symbol is to be applied shall be fabricated by a Manufacturer of boilers, superheaters, waterwalls, or steel economizers who is in possession of the appropriate Code symbol stamp (see Fig. PG-105.1), and a valid certificate of authorization, except as otherwise provided in PG-109.

105.2 Seven Code symbol stamps are shown in Figs. PG-105.1 through PG-105.4. They are defined as follows:

- S—power boiler symbol stamp see Fig. PG-105.1
- M—miniature boiler symbol stamp see Fig. PG-105.1
- L—locomotive boiler symbol stamp see Fig. PG-105.1
- E—electric boiler symbol stamp see Fig. PG-105.1
- A—boiler assembly symbol stamp see Fig. PG-105.2
- PP—pressure piping symbol stamp see Fig. PG-105.3
- V—safety valve symbol stamp see Fig. PG-105.4

SECTION I — POWER BOILERS

PG-109 STAMPING OF PRESSURE
PIPING

109.1 When external piping, as defined in the Preamble, is installed by welding and is fabricated by anyone other than the Manufacturer of the boiler, the welding, other than the qualification of welding procedures, welders, and welding operators, shall be done in accordance with the applicable rules of ANSI B31.1 and by a manufacturer or contractor in possession of one of the Code symbols shown in Fig. PG-105.1 ("S" only), Fig. PG-105.2, or Fig. PG-105.3 and who has been issued a Certificate of Authorization. Qualification of welding procedures, welders, and welding operators shall be in accordance with the requirements of PW-1.2 and Section IX. Such work shall be inspected by an Authorized Inspector at such stages of the work as the Inspector may elect. The organizations which furnish and install such piping shall furnish proper Code certification (PG-104.2) for such piping including a Manufacturer's Data Report Form P-4A as required by PG-112.2.5 and PG-112.3.

109.2 Welded piping, included within the scope of this Code, over 2 in. pipe size shall be stamped with the Code symbol, together with the manufacturer's or contractor's name and serial number. Such stamping shall be on the pipe, valve, or fitting adjacent to the welded joint farthest from the boiler. For piping operating at temperatures above 800°F (427°C) the symbol may be stamped on a nameplate which is irremovably attached by welding, provided such welding is postweld heat treated, or on a circular metal band at least 1/4 in. (6 mm) thick. This band around the pipe shall be secured in such a manner as to prevent it from slipping off during handling and installation.

Welded piping 2 in. pipe size or less included within the scope of this Code shall be marked with an identification acceptable to the Inspector and traceable to the required Data Report. Such marking shall be of a type that will remain visible until the piping has been installed.

109.3 Parts of boilers, such as superheater, water-wall, or economizer headers, or any construction involving only welding as covered by PW-41, may be fabricated by a manufacturer in possession of the pressure piping symbol stamp, and so stamped and reported on a Manufacturers' Partial Data Report Form (Form P-4) as called for in PG-112.2.4.

PG-110 STAMPING OF SAFETY VALVES

Each safety valve shall be plainly marked by the manufacturer or assembler (see PG-73.3.4) in such a way that the markings will not be obliterated in service. The markings may be stamped on the casing, or stamped or cast on a plate or plates securely fastened to the casing, and shall contain the following markings:

- (1) the name or identifying trademark of the manufacturer;
- (2) manufacturer's design or type number;
- (3) size ___ in. seat diameter ___ in. (the pipe size of the valve inlet);
- (4) pressure ___ lb (the pressure at which it is to blow);
- (5) B.D. ___ lb (blowdown—difference between the opening and closing pressure);
- (6) capacity ___ lb/hr (in accordance with PG-67.5 and PG-72, and with the valve adjusted for the blowdown given in the preceding item);
- (7) capacity lift ___ in. (capacity lift—distance the valve disk rises when blowing at the accumulation test pressure);
- (8) year built, or alternatively, a coding may be marked on the valve such that the valve manufacturer can identify the year built;
- (9) ASME symbol as shown in Fig. PG-105.4.

SECTION I — POWER BOILERS

GENERAL

PFT-1 GENERAL

The rules in Part PFT are applicable to firetube boilers and parts thereof and shall be used in conjunction with the general requirements in Part PG as well as with the specific requirements in the applicable Parts of this Section which apply to the method of fabrication used.

PFT-44 OPENING BETWEEN BOILER AND SAFETY VALVE

The opening or connection between the boiler and the safety valve shall have at least the area of the valve inlet. In the case of firetube boilers, the openings in the boilers for safety valves or safety relief valves shall be not less than given in Table PFT-44, except firetube boilers used for waste heat purposes only, not equipped for direct firing, need not meet the requirements of Table PFT-44 provided the rated steaming capacity is stamped on the boiler and safety valves or safety relief valves of the required relieving capacity are supplied such that the provisions of PG-67.2 are satisfied.

After the boiler Manufacturer provides for the opening required by the Code, a bushing may be inserted in the opening in the shell to suit a safety valve that will have the capacity to relieve all the steam that can be generated in the boiler and which will meet the Code requirements.

No valve of any description shall be placed between the required safety valve or safety relief valve or valves and the boiler, or on the discharge pipe between the safety valve or safety relief valve and the atmosphere. When a discharge pipe is used, the cross-sectional area shall be not less than the full area of the valve outlet or of the total of the areas of the valve outlets discharging therinto and shall be as short and straight as possible and so arranged as to avoid undue stresses on the valve or valves.

PFT-48 FEED PIPING

48.1 When a horizontal-return tubular boiler exceeds 40 in. (1000 mm) in diameter, the feedwater shall discharge at about three-fifths the length from the end of the boiler which is subjected to the hottest gases of the furnace (except a horizontal-return tubular boiler equipped with an auxiliary feedwater heating and circulating device), above the central rows of tubes. The feed pipe shall be carried through the head or shell farthest from the point of discharge of the feedwater in the manner specified for a surface blowoff in PG-59.3.2, and be securely fastened inside the shell above the tubes.

48.2 In vertical tubular boilers the feedwater shall be introduced at a point not less than 12 in. (300 mm) above the crown sheet. When the boiler is under pressure, feedwater shall not be introduced through the openings or connections used for the water column, the water gage glass, or the gage cocks. In closed systems the water may be introduced through any opening when the boiler is not under pressure.

PFT-49 BLOWOFF PIPING

49.1 Blowoff piping of firetube boilers which is exposed to products of combustion shall be attached by screwing into a tapped opening with provisions for a screwed fitting or valve at the other end.

49.2 Blowoff piping of firetube boilers which is not exposed to products of combustion may be attached by any method provided in this Section except by expanding into grooved holes.

GENERAL

PEB-1 GENERAL

The rules in Part PEB are applicable to electric boilers and parts thereof and shall be used in conjunction with the general requirements in Part PG as well as with the special requirements in the applicable Parts of this Section which apply to the method of fabrication used.

PEB-15 SAFETY VALVES

15.1 Each electric boiler shall have at least one safety valve or safety relief valve, and if it has a power input more than 500 kW it shall have two or more safety valves or safety relief valves.

15.2 The minimum safety valve or safety relief valve relieving capacity for electric boilers shall be $3\frac{1}{2}$ lb (1.6 kg)/hr/kW input.

EXERPTS FROM:

ASME BOILER AND PRESSURE VESSEL CODE

SECTION IV

HEATING BOILERS

1980 EDITION

PREAMBLE

The rules of this Section of the Code cover minimum construction requirements for the design, fabrication, installation, and inspection of steam heating, hot water heating, hot water supply boilers which are directly fired with oil, gas, electricity, coal or other solid or liquid fuels and for operation at or below the pressure and temperature limits set forth in this document. Similar rules for lined potable water heaters are also included.

The rules are divided into four major Parts: Part HG, applying to all materials of construction except as provided for in Part HLW; Part HF, applying to assemblies fabricated of wrought material, except as provided for in Part HLW; Part HC, applying to cast iron assemblies; and Part HLW, applying to lined potable water heaters. Part HF is further subdivided into Subpart HW, containing rules for welded construction, and Subpart HB, containing rules for brazed construction.

The Parts and Subparts of this Section are divided into Articles. Each Article is given a number and a title, as for example, Part HG, Article 3, Design. Articles are divided into paragraphs which are given a three-digit number, the first of which corresponds to the Article number, thus, under

Article 3 of Part HG will be found paragraph HG-307. Paragraphs are further subdivided into subparagraphs. Major subdivisions of paragraphs are designated by three- or four-digit numbers followed by a decimal point and a digit or digits. Where necessary, further subdivisions are represented by letters and then by figures in parentheses. Minor subdivisions of the paragraphs are also represented by letters. A reference to one of these paragraphs in the text of the Section includes all of the applicable rules in that paragraph. Thus, reference to HG-307 includes all the rules in HG-307.1 through HG-307.4.

This Section does not contain rules to cover all possible details of design and construction. Where complete details are not given, it is intended that the manufacturer, subject to the approval of the Authorized Inspector, shall provide details of design and construction which will be as safe as otherwise required by these rules.

When the strength of any part cannot be computed with a satisfactory assurance of safety, these rules provide procedures for establishing its maximum allowable working pressure.

ARTICLE 1
SCOPE AND SERVICE RESTRICTIONS

HG-100 SCOPE

The requirements of Part HG apply to steam heating boilers¹ and hot water boilers² and to appurtenances thereto and shall be used in conjunction with the specific requirements in Part HF, Boilers of Wrought Materials, and Part HC, Cast Iron Boilers, whichever is applicable. Part HG is not intended to apply to lined potable water heaters except as provided for in Part HLW.

HG-101 SERVICE RESTRICTIONS AND EXCEPTIONS

HG-101.1 Service Restrictions. The rules of this Section are restricted to the following services:

(a) steam boilers for operation at pressures not exceeding 15 psi (103 kPa);

¹When used for services where periodic make-up is required, the user is cautioned that, normally, water treatment must be considered and usually extra provisions for cleanout are necessary.
²As used in this Section, the term "hot water boilers" includes both hot water heating boilers and hot water supply boilers.

(b) hot water heating boilers for operating at pressures not exceeding 160 psi (1103 kPa) and/or temperatures not exceeding 250°F (121°C), at or near the boiler outlet;

(c) hot water supply boilers for operation at pressures not exceeding 160 psi (1103 kPa) and/or temperatures not exceeding 250°F (121°C), at or near the boiler outlet except as otherwise provided in HG-101.2.

HG-101.2 Exceptions. Hot water supply boilers which are directly fired with oil, gas, or electricity are considered outside the jurisdiction of Section IV when none of the following limitations is exceeded:

- (a) heat input of 200,000 Btu/hr (58.6 kW);
- (b) water temperature of 210°F (99°C);
- (c) nominal water containing capacity of 120 gal (454 l) except that such hot water supply boilers shall be equipped with safety devices in accordance with the requirements of HG-400.2.

HG-101.3 Services in Excess of Those Covered by This Section. For services exceeding the limits specified in HG-101.1, the rules of Section I shall apply.

ARTICLE 4 PRESSURE RELIEVING DEVICES

HG-400 PRESSURE RELIEVING VALVE REQUIREMENTS

HG-400.1 Safety Valve Requirements for Steam Boilers

(a) Each steam boiler shall have one or more officially rated safety valves¹ of the spring pop type adjusted and sealed to discharge at a pressure not to exceed 15 psi (103 kPa). Seals shall be attached in a manner to prevent the valve from being taken apart without breaking the seal. The safety valves shall be arranged so that they cannot be reset to relieve at a higher pressure than the maximum allowable working pressure of the boiler. A body drain connection below seat level shall be provided by the manufacturer and this drain shall not be plugged during or after field installation. For valves exceeding 2 in. (51 mm) pipe size, the drain hole or holes shall be tapped not less than $\frac{3}{8}$ in. (10 mm) pipe size. For valves 2 in. (51 mm) pipe size or less, the drain hole shall not be less than $\frac{1}{4}$ in. (6 mm) in diameter.

(b) No safety valve for a steam boiler shall be smaller than $\frac{1}{2}$ in. (13 mm). No safety valve shall be larger than $4\frac{1}{2}$ in. (114 mm). The inlet opening shall have an inside diameter equal to, or greater than, the seat diameter.

(c) The minimum relieving capacity of valve or valves shall be governed by the capacity marking on the boiler called for in HG-530.

(d) The minimum valve capacity in pounds per hour shall be the greater of that determined by dividing the maximum Btu (joule) output at the boiler nozzle obtained by the firing of any fuel for which the unit is installed by 1000, or shall be determined on the basis of the pounds of steam generated per hour per square foot of boiler heating surface as given in Table HG-400.1. In many cases a greater relieving capacity

of valves will have to be provided than the minimum specified by these rules. In every case, the requirement of HG-400.1(e) shall be met.

(e) The safety valve capacity for each steam boiler shall be such that with the fuel burning equipment installed, and operated at maximum capacity, the pressure cannot rise more than 5 psi (34 kPa) above the maximum allowable working pressure.

(f) When operating conditions are changed, or additional boiler heating surface is installed, the valve capacity shall be increased, if necessary, to meet the new conditions and be in accordance with HG-400.1(e). The additional valves required, on account of changed conditions, may be installed on the outlet piping provided there is no intervening valve.

HG-400.2 Safety Relief Valve Requirements for Hot Water Boilers

(a) Each hot water heating boiler shall have at least one officially rated pressure relief valve¹ set to relieve at or below the maximum allowable working pressure of the boiler. Each hot water supply boiler shall have at least one officially rated safety relief valve or at least one officially rated pressure-temperature relief valve of the automatic reseating type set to relieve at or below the maximum allowable working pressure of the boiler. Safety relief valves officially rated as to capacity shall have pop action when tested by steam. When more than one safety relief valve is used on either hot water heating or hot water supply boilers, the additional valve or valves shall be officially rated and may be set within a range not to exceed 6 psi (41 kPa) above the maximum allowable working pressure of the boiler up to and including 60 psi (414 kPa) and 5% for those having a maximum allowable working pressure exceeding 60 psi (414 kPa). Safety relief valves shall be spring loaded. Safety relief valves shall be so arranged that they cannot be reset at a higher pressure than the maximum permitted by this paragraph.

(b) No materials liable to fail due to deterioration or vulcanization when subjected to saturated steam

¹"V" stamped safety valves that have been tested and certified in accordance with the rules of Section I may be accepted for installation on Section IV boilers.

TABLE HG-400.1
MINIMUM POUNDS OF STEAM PER HOUR
PER SQUARE FOOT OF HEATING SURFACE

Boiler Heating Surface	Firetube Boilers	Watertube Boilers
Hand fired	5	6
Stoker fired	7	8
Oil, gas, or pulverized fuel fired	8	10
Waterwall heating surface:		
Hand fired	8	8
Stoker fired	10	12
Oil, gas, or pulverized fuel fired	14	16

NOTES:

- (1) When a boiler is fired only by a gas having a heat value not in excess of 200 Btu/cu ft, the minimum safety valves or safety relief valve relieving capacity may be based on the values given for hand fired boilers above.
- (2) The minimum safety valve or safety relief valve relieving capacity for electric boilers shall be $3\frac{1}{2}$ lb/hr/kW input.
- (3) For heating surface determination, see HG-403.

temperature corresponding to capacity test pressure shall be used for any part.

(c) No safety relief valve shall be smaller than $\frac{3}{4}$ in. (19 mm) nor larger than $4\frac{1}{2}$ -in. (114 mm) standard pipe size except that boilers having a heat input not greater than 15,000 Btu/hr (4395 W) may be equipped with a rated safety relief valve of $\frac{1}{2}$ -in. (13 mm) standard pipe size. The inlet opening shall have an inside diameter approximately equal to, or greater than, the seat diameter. In no case shall the minimum opening through any part of the valve be less than $\frac{1}{4}$ in. (6 mm) in diameter or its equivalent area.

(d) The required steam relieving capacity, in pounds per hour, of the pressure relieving device or devices on a boiler shall be the greater of that determined by dividing the maximum output in Btu (joules) at the boiler nozzle obtained by the firing of any fuel for which the unit is installed by 1000, or shall be determined on the basis of pounds of steam generated per hour per square foot of boiler heating surface as given in Table HG-400.1. In many cases a greater relieving capacity of valves will have to be provided than the minimum specified by these rules. In every case, the requirements of HG-400.2(f) shall be met.

(e) When operating conditions are changed, or additional boiler heating surface is installed, the valve capacity shall be increased, if necessary, to meet the new conditions and shall be in accordance with HG-400.2(f). The additional valves required, on account of

changed conditions, may be installed on the outlet piping provided there is no intervening valve.

(f) Safety relief valve capacity for each boiler with a single safety relief valve shall be such that, with the fuel burning equipment installed and operated at maximum capacity, the pressure cannot rise more than 10% above the maximum allowable working pressure. When more than one safety relief valve is used, the overpressure shall be limited to 10% above the set pressure of the highest set valve allowed by HG-400.2(a).

HG-400.3 Safety and Safety Relief Valves for Tanks and Heat Exchangers

(a) *Steam to Hot Water Supply.* When a hot water supply is heated indirectly by steam in a coil or pipe within the service limitations set forth in HG-101, the pressure of the steam used shall not exceed the safe working pressure of the hot water tank, and a safety relief valve at least 1 in. (25 mm) in diameter, set to relieve at or below the maximum allowable working pressure of the tank, shall be applied on the tank.

(b) *High-Temperature Water to Water Heat Exchanger.*² When high-temperature water is circulated through the coils or tubes of a heat exchanger to warm water for space heating or hot water supply, within the service limitations set forth in HG-101, the heat exchanger shall be equipped with one or more officially rated safety relief valves, set to relieve at or below the maximum allowable working pressure of the heat exchanger, and of sufficient rated capacity to prevent the heat exchanger pressure from rising more than 10% above the maximum allowable working pressure of the vessel.

(c) *High-Temperature Water to Steam Heat Exchanger.*² When high-temperature water is circulated through the coils or tubes of a heat exchanger to generate low-pressure steam, within the service limitations set forth in HG-101, the heat exchanger shall be equipped with one or more officially rated safety valves, set to relieve at a pressure not to exceed 15 psi (103 kPa), and of sufficient rated capacity to prevent the heat exchanger pressure from rising more than 5 psi (34 kPa) above the maximum allowable working pressure of the vessel. For heat exchangers requiring steam pressures greater than 15 psi (103 kPa), refer to Section I or Section VIII, Division 1.

²Suggested installation practices for the secondary side of heat exchangers.

HG-402 DISCHARGE CAPACITIES OF SAFETY AND SAFETY RELIEF VALVES

HG-402.1 Valve Markings. Each safety or safety relief valve shall be plainly marked by the manufacturer in such a way that the markings will not be obliterated in service. The markings shall be cast or stamped on the valve body or on the lifting lever,



FIG. HG-402 OFFICIAL SYMBOL FOR STAMP TO DENOTE THE AMERICAN SOCIETY OF MECHANICAL ENGINEERS' STANDARD

providing the lifting lever is permanently attached to the valve, or, when desirable because of size, all or part of the required markings may be stamped, cast or etched on a plate or plates, each securely fastened to the valve body, lever, or other permanent part of the valve, and such markings shall include the following:

- (a) the name or identifying trademark of the manufacturer;
- (b) manufacturer's design or type number;
- (c) size _____ in. (the pipe size of the inlet);
- (d) pressure _____ psi (the pressure at which it is set to blow³);
- (e) capacity _____ lb/hr, or capacity _____ Btu/hr in accordance with HG-402.3;
- (f) year built or alternatively, a coding may be marked on the valves such that the valve manufacturer can identify the year built;
- (g) ASME symbol as shown in Fig. HG-402.

HG-406 VALVE REPLACEMENT

Safety valves and safety relief valves requiring repairs shall be replaced with a new valve or repaired by the manufacturer.

ARTICLE 6
INSTRUMENTS, FITTINGS, AND CONTROLS¹

HG-600 FOR STEAM HEATING BOILERS

HG-601 STEAM GAGES

(a) Each steam boiler shall have a steam gage or a compound steam gage connected to its steam space or to its water column or to its steam connection. The gage or connection shall contain a siphon or equivalent device which will develop and maintain a water seal that will prevent steam from entering the gage tube. The connection shall be so arranged that the gage cannot be shut off from the boiler except by a cock placed in the pipe at the gage and provided with a tee- or lever-handle arranged to be parallel to the pipe in which it is located when the cock is open. The connections to the boiler shall be not less than $\frac{1}{4}$ in. (6 mm) standard pipe size, but where steel or wrought iron pipe or tubing is used, they shall be not less than $\frac{1}{2}$ in. (13 mm) standard pipe size. The minimum size of a siphon, if used, shall be $\frac{1}{4}$ in. (6 mm) in inside diameter. Ferrous and nonferrous tubing having inside diameters at least equal to that of standard pipe sizes listed above may be substituted for pipe.

(b) The scale on the dial of a steam boiler gage shall be graduated to not less than 30 psi (207 kPa) nor more than 60 psi (414 kPa). The travel of the pointer from 0 to 30 psi (0 to 207 kPa) pressure shall be at least 3 in. (76 mm).

HG-602 WATER GAGE GLASSES

(a) Each steam boiler shall have one or more water gage glasses attached to the water column or boiler by means of valved fittings not less than $\frac{1}{2}$ in. (13 mm) pipe size, with the lower fitting provided with a drain valve of a type having an unrestricted drain opening not less than $\frac{1}{4}$ in. (6 mm) in diameter to facilitate cleaning. Gage glass replacement shall be possible

under pressure. Water glass fittings may be attached directly to a boiler.

Boilers having an internal vertical height of less than 10 in. (254 mm) may be equipped with a water level indicator of the Glass Bull's-Eye type provided the indicator is of sufficient size to show the water at both normal operating and low water cutoff levels.

(b) The lowest visible part of the water gage glass shall be at least 1 in. (25 mm) above the lowest permissible water level recommended by the boiler manufacturer. With the boiler operating at this lowest permissible water level, there shall be no danger of overheating any part of the boiler.

Each boiler shall be provided at the time of the manufacture with a permanent marker indicating the lowest permissible water level. The marker shall be stamped, etched, or cast in metal; or it shall be a metallic plate attached by rivets, screws, or welding; or it shall consist of material with documented tests² showing its suitability as a permanent marking for the application. This marker shall be visible at all times. Where the boiler is shipped with a jacket, this marker may be located on the jacket.

NOTE: Transparent material other than glass may be used for the water gage provided that the material will remain transparent and has proved suitable for the pressure, temperature, and corrosive conditions expected in service.

(c) In electric boilers of the submerged electrode type, the water gage glass shall be so located to indicate the water levels both at startup and under maximum steam load conditions as established by the manufacturer.

(d) In electric boilers of the resistance heating element type the lowest visible part of the water gage glass shall not be below the top of the electric resistance heating element. Each boiler of this type shall also be equipped with an automatic low-water

¹This equipment to be installed prior to operation.

²Example of a nationally recognized standard is ANSI Z21 13.

II,HR 42

HG-602-HG-605

SECTION IV — PART HG

electrical power cutoff so located as to automatically cut off the power supply before the surface of the water falls below the top of the electrical resistance heating elements.

(e) Tubular water glasses on electric boilers having a normal water content not exceeding 100 gal (379 l) shall be equipped with a protective shield.

HG-603 WATER COLUMN AND WATER LEVEL CONTROL PIPES

(a) The minimum size of ferrous or nonferrous pipes connecting a water column to a steam boiler shall be 1 in. (25 mm). No outlet connections, except for damper regulator, feedwater regulator, steam gages, or apparatus which does not permit the escape of any steam or water except for manually operated blowdowns, shall be attached to a water column or the piping connecting a water column to a boiler (see HG-705 for introduction of feedwater into a boiler). If the water column, gage glass, low-water fuel cutoff, or other water level control device is connected to the boiler by pipe and fittings, no shutoff valves of any type shall be placed in such pipe, and a cross or equivalent fitting to which a drain valve and piping may be attached shall be placed in the water piping connection at every right angle turn to facilitate cleaning. The water column drain pipe and valve shall be not less than $\frac{3}{4}$ in. (19 mm) pipe size.

(b) The steam connections to the water column of a horizontal firetube wrought boiler shall be taken from the top of the shell or the upper part of the head, and the water connection shall be taken from a point not above the center line of the shell. For a cast iron boiler, the steam connection to the water column shall be taken from the top of an end section or the top of the steam header, and the water connection shall be made on an end section not less than 6 in. (152 mm) below the bottom connection to the water gage glass.

HG-604 PRESSURE CONTROL

Each automatically fired steam boiler shall be protected from overpressure by two pressure-operated controls.

(a) Each individual automatically fired steam boiler shall have a safety limit control that will cut off the fuel supply to prevent steam pressure from exceeding the 15 psi (103 kPa) maximum allowable working pressure of the boiler. Each control shall be constructed to prevent a pressure setting above 15 psi (103 kPa).

(b) Each individual steam boiler or each system of commonly connected steam boilers shall have a control that will cut off the fuel supply when the pressure reaches an operating limit, which shall be less than the maximum allowable pressure.

(c) Shutoff valves of any type shall not be placed in the steam pressure connection between the boiler and the controls described in (a) and (b) above. These controls shall be protected with a syphon or equivalent means of maintaining a water seal that will prevent steam from entering the control. The connections to the boiler shall not be less than $\frac{1}{4}$ in. (6 mm) standard pipe size, but where steel or wrought iron pipe or tubing is used, they shall not be less than $\frac{1}{2}$ in. (13 mm) standard pipe size. The minimum size of a syphon shall be $\frac{1}{4}$ in. (6 mm) standard pipe size or $\frac{3}{8}$ in. (10 mm) O.D. nonferrous tubing.

HG-605 AUTOMATIC LOW-WATER FUEL CUTOFF AND/OR WATER FEEDING DEVICE

(a) Each automatically fired steam or vapor-system boiler shall have an automatic low-water fuel cutoff so located as to automatically cut off the fuel supply when the surface of the water falls to the lowest visible part of the water gage glass. If a water feeding device is installed, it shall be so constructed that the water inlet valve cannot feed water into the boiler through the float chamber and so located as to supply requisite feedwater.

(b) Such a fuel cutoff or water feeding device may be attached directly to a boiler. A fuel cutoff or water feeding device may also be installed in the tapped openings available for attaching a water glass direct to a boiler, provided the connections are made to the boiler with nonferrous tees or Y's not less than $\frac{1}{2}$ in. (13 mm) pipe size between the boiler and the water glass so that the water glass is attached directly and as close as possible to the boiler; the run of the tee or Y shall take the water glass fittings, and the side outlet or branch of the tee or Y shall take the fuel cutoff or water feeding device. The ends of all nipples shall be reamed to full-size diameter.

(c) Fuel cutoffs and water feeding devices embodying a separate chamber shall have a vertical drain pipe and a blowoff valve not less than $\frac{3}{4}$ in. (19 mm) pipe size, located at the lowest point in the water equalizing pipe connections so that the chamber and the equalizing pipe can be flushed and the device tested.

DEPT. OF INDUSTRY, LABOR & HUMAN RELATIONS 119
ILHR 42

ARTICLE 6 — INSTRUMENTS, FITTINGS, AND CONTROLS

HG-610-HG-632

HG-610 FOR HOT WATER BOILERS

HG-611 PRESSURE OR ALTITUDE GAGES

(a) Each hot water boiler shall have a pressure or altitude gage connected to it or to its flow connection in such a manner that it cannot be shut off from the boiler except by a cock with tee or lever handle, placed on the pipe near the gage. The handle of the cock shall be parallel to the pipe in which it is located when the cock is open.

(b) The scale on the dial of the pressure or altitude gage shall be graduated approximately to not less than $1\frac{1}{2}$ nor more than three times the pressure at which the safety relief valve is set.

(c) Piping or tubing for pressure- or altitude-gage connections shall be of nonferrous metal when smaller than 1 in. (25 mm) pipe size.

HG-612 THERMOMETERS

Each hot water boiler shall have a thermometer so located and connected that it shall be easily readable when observing the water pressure or altitude. The thermometer shall be so located that it shall at all times indicate the temperature in degrees Fahrenheit of the water in the boiler at or near the outlet.

HG-613 TEMPERATURE CONTROL

Each automatically fired hot water boiler shall be protected from over-temperature by two temperature-operated controls.

(a) Each individual automatically fired hot water boiler shall have a safety limit control that will cut off the fuel supply to prevent water temperature from exceeding the maximum allowable temperature of 250°F (121°C) at the boiler outlet. This water temperature safety control shall be constructed to prevent a temperature setting above 250°F (121°C).

(b) Each individual hot water boiler or each system of commonly connected boilers without intervening valves shall have a control that will cut off the fuel supply when the water temperature reaches an operating limit, which shall be less than the maximum allowable temperature.

HG-614 LOW-WATER FUEL CUTOFF

(a) Each automatically fired hot water heating boiler with heat input greater than 400,000 Btu/hr (117.2 kW) shall have an automatic low-water fuel

cutoff which has been designed for hot water service, and it shall be so located as to automatically cut off the fuel supply when the surface of the water falls to the level established in (b) below (see Fig. HG-703.2).

(b) As there is no normal waterline to be maintained in a hot water heating boiler, any location of the low-water fuel cutoff above the lowest safe permissible water level established by the boiler manufacturer is satisfactory.

(c) A coil-type boiler or a watertube boiler with heat input greater than 400,000 Btu/hr (117.2 kW) requiring forced circulation to prevent overheating of the coils or tubes shall have a flow-sensing device installed in the outlet piping in lieu of the low-water fuel cutoff required in (a) above to automatically cut off the fuel supply when the circulating flow is interrupted.

HG-620 FOR ALL BOILERS

HG-621 INSTRUMENTS, FITTINGS, AND CONTROLS MOUNTED INSIDE BOILER JACKETS

Any or all instruments, fittings, and controls required by these rules may be installed inside of boiler jackets provided the water gage on a steam boiler is accessible without the use of tools and provided the water gage and pressure gage on a steam boiler or the thermometer and pressure gage on a water boiler are visible through an opening or openings at all times.

HG-630 ELECTRIC WIRING

HG-631 ELECTRICAL CODE COMPLIANCE

All field wiring for controls, heat generating apparatus, and other appurtenances necessary for the operation of the boiler or boilers should be installed in accordance with the provisions of the National Electric Code and/or should comply with the applicable local electrical codes. All boilers supplied with factory mounted and wired controls, heat generating apparatus, and other appurtenances necessary for the operation of the boilers should be installed in accordance with the provisions of the nationally recognized standards such as listed in footnote 1 of HG-640.

HG-632 TYPE CIRCUITRY TO BE USED

Whether field or factory wired, the control circuitry

shall be positively grounded and shall operate at 150 V or less. One of the two following systems may be employed to provide the control circuit:

(a) Two-Wire Nominal 120 V System With Separate Equipment Ground Conductor

(1) This system shall consist of the line, neutral, and equipment ground conductors. The control panel frame and associated control circuitry metallic enclosures shall be electrically continuous and be bonded to the equipment ground conductor.

(2) The equipment ground conductor and the neutral conductor shall be bonded together at their origin in the electrical system as required by the NEC.³

(3) The line side of the control circuit shall be provided with a time delay fuse sized as small as practicable.

(b) Two-Wire Nominal 120 V System Obtained by Using an Isolation Transformer

(1) The two-wire control circuit shall be obtained from the secondary side of an isolation transformer. One wire from the secondary of this transformer shall be electrically continuous and shall be bonded to a convenient cold water pipe. All metallic enclosures of control components shall be securely bonded to this ground control circuit wire. The primary side of the isolation transformer will normally be a two-wire source with a potential of 230 or 208 V or 440 V.

(2) Both sides of the two-wire primary circuit shall be fused. The hot leg on the load side of the isolation transformer shall be fused as small as practicable and in no case fused above the rating of the isolation transformer.

HG-633 LIMIT CONTROLS

Limit controls shall be wired on the hot or line side of the control circuit.

³See Appendix H.

HG-634 SHUTDOWN SWITCHES AND CIRCUIT BREAKERS

A manually operated remote heating plant shutdown switch or circuit breaker should be located just outside the boiler room door and marked for easy identification. Consideration should also be given to the type and location of the switch to safeguard against tampering. If the boiler room door is on the building exterior the switch should be located just inside the door. If there is more than one door to the boiler room, there should be a switch located at each door.

HG-640 CONTROLS AND HEAT GENERATING APPARATUS

(a) Oil and gas-fired and electrically heated boilers should be equipped with suitable primary (flame safeguard) safety controls, safety limit switches, and burners or electric elements as required by a nationally recognized standard.⁴

(b) The symbol of the certifying organization⁵ which has investigated such equipment as having complied with a nationally recognized standard shall be affixed to the equipment and shall be considered as evidence that the unit was manufactured in accordance with that standard.

⁴Examples of these nationally recognized standards are:
American National Standards Z21.13.1, Central Heating Gas Appliances, Volume I, Steam and Hot Water Boilers.
American National Standards Z21.17, Domestic Gas Conversion Burners.
Underwriters' Laboratories, Inc., UL 296, Standards for Safety, Oil Burners.
Underwriters' Laboratories, Inc., UL 573, Electric Space Heating Equipment.
Underwriters' Laboratories, Inc., UL 726, Standards for Safety, Oil Fired Boiler Assemblies.
Underwriters' Laboratories, Inc., UL 795, Standards for Safety Commercial—Industrial Gas-Heating Equipment.

⁵A certifying organization is one that provides uniform testing, examination, and listing procedures under established, nationally recognized standards and that is acceptable to the authorities having jurisdiction.

ARTICLE 7
INSTALLATION REQUIREMENTS

**HG-700 INSTALLATION REQUIREMENTS,
ALL BOILERS**

**HG-701 MOUNTING SAFETY AND
SAFETY RELIEF VALVES**

HG-701.1 Permissible Mounting. Safety valves and safety relief valves shall be located in the top or side¹ of the boiler. They shall be connected directly to a tapped or flanged opening in the boiler, to a fitting connected to the boiler by a short nipple, to a Y-base, or to a valveless header connecting steam or water outlets on the same boiler. Coil or header type boilers shall have the safety valve or safety relief valve located on the steam or hot water outlet end. Safety valves and safety relief valves shall be installed with their spindles vertical. The opening or connection between the boiler and any safety valve or safety relief valve shall have at least the area of the valve inlet.

HG-701.2 Requirements for Common Connections for Two or More Valves

(a) When a boiler is fitted with two or more safety valves on one connection, this connection shall have a cross-sectional area not less than the combined areas of inlet connections of all the safety valves with which it connects.

(b) When a Y-base is used, the inlet area shall be not less than the combined outlet areas. When the size of the boiler requires a safety valve or safety relief valve larger than 4½ in. (114 mm) in diameter, two or more valves having the required combined capacity shall be used. When two or more valves are used on a boiler, they may be single, directly attached, or mounted on a Y-base.

HG-701.3 Threaded Connections. A threaded connection may be used for attaching a valve.

¹The top or side of the boiler shall mean the highest practicable part of the boiler proper but in no case shall the safety valves or safety relief valves be located on the boiler below the lowest permissible water level.

HG-701.4 Prohibited Mountings. Safety and safety relief valves shall not be connected to an internal pipe in the boiler.

HG-701.5 Use of Shutoff Valves Prohibited. No shutoff of any description shall be placed between the safety or safety relief valve and the boiler, or on discharge pipes between such valves and the atmosphere.

HG-701.6 Safety and Safety Relief Valve Discharge Piping

(a) When a discharge pipe is used, its internal cross-sectional area shall be not less than the full area of the valve outlet or of the total of the valve outlets discharging thereto and shall be as short and straight as possible and so arranged as to avoid undue stress on the valve or valves. When an elbow is placed on a safety or safety relief valve discharge pipe, it shall be located close to the valve outlet.

(b) The discharge from safety or safety relief valves shall be so arranged that there will be no danger of scalding attendants. When the safety or safety relief valve discharge is piped away from the boiler to the point of discharge, there shall be provisions made for properly draining the piping. The size and arrangement of discharge piping shall be such that any pressure that may exist or develop will not reduce the relieving capacity of the relieving devices below that required to protect the boiler.

HG-703 PIPING

HG-703.1 Provisions for Expansion and Contraction. Provisions shall be made for the expansion and contraction of steam and hot water mains connected to boilers by providing substantial anchorage at suitable points and by providing swing joints² when

²Regardless of type of connection used, the term "swing joints" means arrangements of pipe and fittings, such as illustrated in Figs. HG-703.1 and HG-703.2, which allow the piping to expand without imposing excessive force on the boiler.

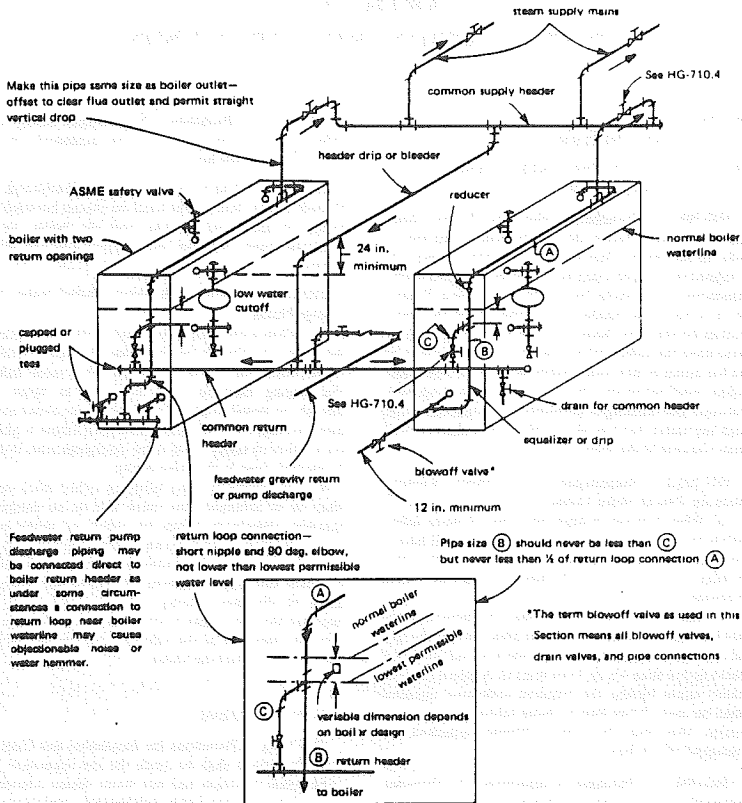

NOTES:

- (1) Return loop connection was designed to eliminate necessity of check valves on gravity return systems, but in some localities a check valve is a legal requirement.
- (2) When pump discharge piping exceeds 25 ft, install swing check valves at pump discharge.
- (3) If pump discharge is looped above normal boiler waterline, install a spring-loaded check valve at return header and at pump discharge.
- (4) Where supply pressures are adequate, makeup water may be introduced directly to a boiler through an independent connection. See HG-705.
- (5) Return connections shown for a multiple boiler installation may not always insure that the system will operate properly. In order to maintain proper water levels in multiple boiler installations, it may be necessary to install supplementary controls or suitable devices.

FIG. HG-703.1 AN ACCEPTABLE PIPING INSTALLATION FOR STEAM BOILERS IN BATTERY

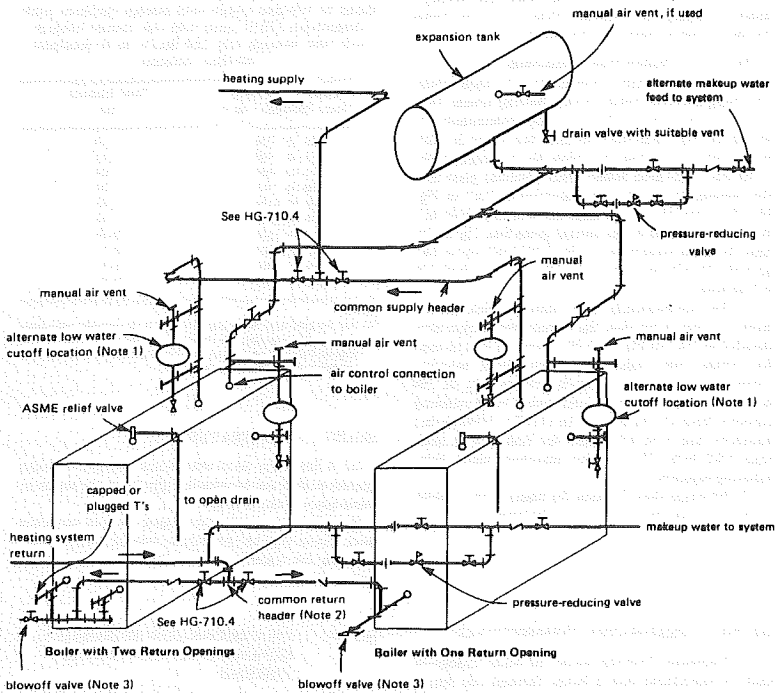

NOTES:

- (1) Recommended control. See HG-614. Acceptable shutoff valves or cocks in the connecting piping may be installed for convenience of control testing and/or service.
- (2) The common return header stop valves may be located on either side of the check valves.
- (3) The term *blowoff valve* as used in this Section means all blowoff valves, drain valves, and pipe connections

FIG. HG-703.2 AN ACCEPTABLE PIPING INSTALLATION FOR HOT WATER HEATING BOILERS IN BATTERY

LLHR 42

HG-703.1-HG-709.2

SECTION IV — PART HG

boilers are installed in batteries, so there will be no undue strain transmitted to the boilers. See Figs. HG-703.1 and HG-703.2 for typical schematic arrangements of piping incorporating strain absorbing joints for steam and hot water heating boilers.

HG-703.2 Return Pipe Connections

(a) The return pipe connections of each boiler supplying a gravity return steam heating system shall be so arranged as to form a loop substantially as shown in Fig. HG-703.1 so that the water in each boiler cannot be forced out below the safe water level.

(b) For hand-fired boilers with a normal grate line, the recommended pipe sizes detailed as "A" in Fig. HG-703.1 are 1½ in. (38 mm) for 4 sq ft (0.0037 m²) or less firebox area at the normal grate line, 2½ in. (64 mm) for areas more than 4 sq ft (0.0037 m²) up to 14.9 sq ft (0.138 m²), and 4 in. (102 mm) for 15 sq ft (0.139 m²) or more.

(c) For automatically fired boilers which do not have a normal grate line, the recommended pipe sizes detailed as "A" in Fig. HG-703.1 are 1½ in. (38 mm) for boilers with minimum safety valve relieving capacity 250 lb/hr (1130 kg/hr) or less, 2½ in. (64 mm) for boilers with minimum safety valve relieving capacity from 251 to 2000 lb/hr (1137 to 9060 kg/hr) inclusive, and 4 in. (102 mm) for boilers with more than 2000 lb/hr (9060 kg/hr) minimum safety valve relieving capacity.

(d) Provision shall be made for cleaning the interior of the return piping at or close to the boiler.

HG-705 FEEDWATER CONNECTIONS

(a) Feedwater, makeup water, or water treatment shall be introduced into a boiler through the return piping system. Alternatively, makeup water or water treatment may be introduced through an independent connection. The water flow from the independent connection shall not discharge directly against parts of the boiler exposed to direct radiant heat from the fire. Makeup water or water treatment shall not be introduced through openings or connections provided for inspection or cleaning, safety valve, safety relief valve, blowoff, water column, water gage glass, pressure gage, or temperature gage.

(b) The makeup water pipe shall be provided with a check valve near the boiler and a stop valve or cock between the check valve and the boiler or between the check valve and the return pipe system.

TABLE HG-709.1
EXPANSION TANK CAPACITIES FOR GRAVITY
HOT WATER SYSTEMS

Based on two-pipe system with average operating water temperature 170°F, using cast iron column radiation with heat emission rate 150 Btu/hr sq ft equivalent direct radiation

Installed Equivalent Direct Radiation, ¹ sq ft	Tank Capacity, gal
Up to 350	18
Up to 450	21
Up to 650	24
Up to 900	30
Up to 1100	35
Up to 1400	40
Up to 1600	2-30
Up to 1800	2-30
Up to 2000	2-35
Up to 2400	2-40

NOTE:

(1) For systems with more than 2400 sq ft of installed equivalent direct water radiation, the required capacity of the cushion tank shall be increased on the basis of 1 gal tank capacity/33 sq ft of additional equivalent direct radiation.

HG-707 OIL HEATERS

(a) A heater for oil or other liquid harmful to boiler operation shall not be installed directly in the steam or water space within a boiler.

(b) Where an external type heater for such service is used, means shall be provided to prevent the introduction into the boiler of oil or other liquid harmful to boiler operation.

**HG-709 PROVISIONS FOR THERMAL
EXPANSION IN HOT WATER
SYSTEMS**

All hot water heating systems incorporating hot water tanks or fluid relief columns shall be so installed as to prevent freezing under normal operating conditions.

HG-709.1 Systems With Open Expansion Tank. If the system is equipped with an open expansion tank, an indoor overflow from the upper portion of the expansion tank shall be provided in addition to an open vent, the indoor overflow to be carried within the building to a suitable plumbing fixture or the basement.

HG-709.2 Closed Type Systems. If the system is of the closed type, an airtight tank or other suitable air

TABLE HG-709.2
EXPANSION TANK CAPACITIES FOR FORCED
HOT WATER SYSTEMS

Based on average operating water temperature 195°F,
a fill pressure 12 psig, and maximum operating pressure
30 psig

System Volume, ¹ gal	Tank Capacity, gal
100	15
200	30
300	45
400	60
500	75
1000	150
2000	300

NOTE:

(1) Includes volume water in boiler, radiation, and piping, not including expansion tank. A procedure for estimating system volume and for determining expansion tank sizes for other design conditions may be referred to in Chapter 10 of the 1964 edition of the ASHRAE Guide and Data Book Applications.

cushion shall be installed that will be consistent with the volume and capacity of the system, and it shall be suitably designed for a hydrostatic test pressure of 2½ times the allowable working pressure of the system. Expansion tanks for systems designed to operate above 30 psi (207 kPa) shall be constructed in accordance with Section VIII, Division 1. Provisions shall be made for draining the tank without emptying the system, except for prepressurized tanks.

HG-709.3 Minimum Capacity of Closed Type Tank. The minimum capacity of the closed type expansion tank may be determined from Tables HG-709.1 and HG-709.2 or from the following formula where the necessary information is available:

$$V_t = [(0.00041T - 0.0466)V_s] / [(P_o/P_f) - (P_o/P_o)]$$

where

- V_t = minimum volume of tanks, gal
- V_s = volume of system, not including tanks, gal
- T = average operating temperature, °F
- P_o = atmospheric pressure, psi
- P_f = fill pressure, psi
- P_o = maximum operating pressure, psi

HG-709.4 Provisions for Thermal Expansion in Hot Water Supply Systems. If a system is equipped with a check valve or pressure-reducing valve in the cold water inlet line, consideration should be given to the installation of an airtight expansion tank or other suitable air cushion. Otherwise, due to the thermal

expansion of the water, the safety relief valve may lift periodically. If an expansion tank is provided, it shall be constructed in accordance with Section VIII, Division 1, for a maximum allowable working pressure equal to or greater than the water heater. Except for prepressurized tanks, provisions shall be made for draining the tank without emptying the system. See Fig. HLW-703.2 for a typical acceptable installation.

HG-710 STOP VALVES

HG-710.1 For Single Steam Boilers. When a stop valve is used in the supply pipe connection of a single steam boiler, there shall be one used in the return pipe connection.

HG-710.2 For Single Hot Water Heating Boilers

(a) Stop valves shall be located at an accessible point in the supply and return pipe connections as near the boiler nozzle as is convenient and practicable, of a single hot water heating boiler installation to permit draining the boiler without emptying the system.

(b) When the boiler is located above the system and can be drained without draining the system, stop valves may be eliminated.

HG-710.3 For Multiple Boiler Installations.

A stop valve shall be used in each supply and return pipe connection of two or more boilers connected to a common system. See Figs. HG-703.1 and HG-703.2.

HG-710.4 Type of Stop Valve(s)

(a) All valves or cocks shall conform with the applicable portions of HF-203 and may be ferrous or nonferrous.

(b) The minimum pressure rating of all valves or cocks shall be at least equal to the pressure stamped upon the boiler, and the temperature rating of such valves or cocks, including all internal components, shall be not less than 250°F (121°C).

(c) Valves or cocks shall be flanged, threaded or have ends suitable for welding or brazing.

(d) All valves or cocks with stems or spindles shall have adjustable pressure type packing glands and, in addition, all plug type cocks shall be equipped with a guard or gland. The plug or other operating mechanism shall be distinctly marked in line with the passage to indicate whether it is opened or closed.

(e) All valves or cocks shall have tight closure when under boiler hydrostatic test pressure.

HG-710.5 Identification of Stop Valves by Tags. When stop valves are used, they shall be properly designated substantially as follows by tags of metal or other durable material fastened to them:

Supply Valve - Number ()

Do Not Close Without Also
Closing Return Valve -
Number ()

Return Valve - Number ()

Do Not Close Without Also
Closing Supply Valve -
Number ()

HG-715 BOTTOM BLOWOFF OR DRAIN VALVE

(a) Each boiler³ shall have a bottom blowoff or drain pipe connection fitted with a valve or cock connected with the lowest water space practicable, with the minimum size of blowoff piping and valves as shown in Table HG-715. Drain and blowoff valves may be installed in the piping adjacent to the boiler as shown in Figs. HG-703.1 and HG-703.2.

(b) Any discharge piping connected to bottom blowoff and/or bottom drain connection shall be full size to the point of discharge.

(c) The minimum pressure rating of blowoff or drain valves and/or cocks shall be equal to the pressure stamped on the boiler but in no case less than 30 psi (207 kPa). The temperature rating of such valves and/or cocks shall be not less than 250°F (121°C).

HG-720 SETTING

Boilers of wrought materials of the wet-bottom type having an external width of over 36 in. (914 mm) shall have not less than 12 in. (305 mm) between the bottom of the boiler and the floorline, with access for inspection. When the width is 36 in. (914 mm) or less, the distance between the bottom of the boiler and the floorline shall be not less than 6 in. (152 mm), except that, when any part of the wet bottom is not farther from an outer edge than 12 in. (305 mm), this distance shall be not less than 4 in. (102 mm).

³Boilers having a capacity of 25 gal (95 l) or less are exempt from the above requirements except that they must have a ¾ in. (19 mm) pipe size minimum drain valve.

TABLE HG-715
SIZE OF BOTTOM BLOWOFF¹ PIPING
AND VALVES

Minimum Required Safety or Safety Relief Valve Capacity, lb of steam/hr (Note (2))	Blowoff Valves Size, in.
Up to 500	¾
501 to 1250	1
1251 to 2500	1¼
2501 to 6000	1½
6001 and larger	2

NOTES:

- (1) The term blowoff valve as used in this Section means all blowoff valves, drain valves, and pipe connections.
- (2) To determine the discharge capacity of safety relief valves in terms of Btu, the relieving capacity in lb of steam/hr is multiplied by 1000.

DEPT. OF INDUSTRY, LABOR & HUMAN RELATIONS 127
ILHR 42

EXERPTS FROM:

ASME BOILER AND PRESSURE VESSEL CODE

SECTION VIII

PRESSURE VESSELS

1980 EDITION

INTRODUCTION

SCOPE

U-1 SCOPE¹

(a) For the scope of this Division, pressure vessels are containers for the containment of pressure, either internal or external. This pressure may be obtained from an external source, or by the application of heat from a direct or indirect source, or any combination thereof.

(b) This Division is divided into three Subsections. Subsection A consists of Part UG, covering the general requirements applicable to all pressure vessels. Subsection B covers the specific requirements that are applicable to the various methods used in the fabrication of pressure vessels. It consists of Parts UW, UF, and UB, dealing with welded, forged, and brazed methods, respectively. Subsection C covers specific requirements applicable to the several classes of materials used in pressure vessel construction. It consists of Parts UCS, UNF, UHA, UCI, UCL, UCD, and UHT, dealing with carbon and low-alloy steels, nonferrous metals, high-alloy steels, cast iron, clad and lined material, cast ductile iron, and ferritic steels with properties enhanced by heat treatment, respectively.

(c) The following classes of vessels are not considered to be within the scope of this Division:

- (1) those within the scope of other Sections
- (2) fired process tubular heaters
- (3) pressure containers which are integral parts or components of rotating or reciprocating mechanical devices, such as pumps, compressors, turbines, generators, engines, and hydraulic or pneumatic cylinders where the primary design considerations and/or stresses are derived from the functional requirements of the device
- (4) except as covered in U-1(f), structures whose

¹In those applications where there are laws or regulations issued by Municipal, State, Provincial or Federal Authorities covering pressure vessels, these laws or regulations should be reviewed to determine size or service limitations of the coverage which may be different or more restrictive than those given in this paragraph.

primary function is the transport of fluids from one location to another within a system of which it is an integral part, that is, piping systems

(5) piping components, such as pipe, flanges, bolting, gaskets, valves, expansion joints, fittings, and the pressure-containing parts of other components, such as strainers and devices which serve such purposes as mixing, separating, snubbing, distributing, and metering or controlling flow, providing that pressure-containing parts of such components are generally recognized as piping components or accessories

(6) vessels with a nominal water-containing capacity of 120 gal (454 l) or less for containing water² under pressure, including those containing air, the compression of which serves only a cushion

(7) a hot water supply storage tank heated by steam or any other indirect means when none of the following limitations is exceeded:

- (a) a heat input of 200,000 Btu/hr (58.6 kW)
- (b) a water temperature of 210°F (99°C)
- (c) a nominal water-containing capacity of 120 gal (454 l)

(8) vessels having an internal or external operating pressure [see 3-1(f)] not exceeding 15 psi (103 kPa) with no limitation on size [see UG-28(e)]

(9) vessels having an inside diameter, width, height, or cross section diagonal not exceeding 6 in. (152 mm), with no limitation on length of vessel or pressure

(d) The rules of this Division have been formulated on the basis of design principles and construction practices applicable to vessels designed for pressures not exceeding 3,000 psi (20 670 kPa). For pressures above 3,000 psi (20 670 kPa), deviations from and additions to these rules usually are necessary to meet the requirements of design principles and construction practices for these higher pressures. Only in the event that after having applied these additional design principles and construction practices the vessel still

²The water may contain additives provided the flash point of the aqueous solution at atmospheric pressure is 185°F (85°C) or higher.

DEPT. OF INDUSTRY, LABOR & HUMAN RELATIONS 129
ILHR 42

U-1-U-3

SECTION VIII — DIVISION I

complies with all of the requirements of this Division may it be stamped with the applicable Code symbol.

(e) In relation to the geometry of pressure-containing parts, the scope of this Division shall include the following:

(1) where external piping is to be connected to the vessel:

(a) the welding end connection for the first circumferential joint for welded connections

(b) the first threaded joint for screwed connections

(c) the face of the first flange for bolted, flanged connections

(d) the first sealing surface for proprietary connections or fittings

(2) where nonpressure parts are welded directly to either the internal or external surface of a pressure vessel, the weld attaching the part to the vessel (see UG-54, UG-55 and Appendices D and G)

(3) pressure-retaining covers for vessel openings, such as manhole and handhole covers

(4) the first sealing surface for proprietary fittings for which rules are not provided by this Division, such as gages and instruments

(f) The scope of the Division includes provisions for pressure relief devices necessary to satisfy the requirements of UG-125 through UG-136 and Appendix 11.

(g) Unfired steam boilers as defined in Section I shall be constructed in accordance with the rules of Section I or this Division [see UG-125(b) and UW-2(c)].

The following pressure vessels in which steam is generated shall be constructed in accordance with the rules of this Division:

(1) vessels known as evaporators or heat exchangers

(2) vessels in which steam is generated by the use of heat resulting from operation of a processing system containing a number of pressure vessels such as used in the manufacture of chemical and petroleum products

(h) Pressure vessels or parts subject to direct firing from the combustion of fuel (solid, liquid, or gaseous), which are not within the scope of Sections I, III, or IV may be constructed in accordance with the rules of this Division [see UW-2(d)].

(i) Any pressure vessel which meets all of the requirements of this Division, including those for inspection, may be stamped with the Code "U" symbol even though exempted from such stamping.

(j) Pressure vessels exclusive of those covered in (c), (g), and (h) that are not required by the rules of

this Division to be fully radiographed, which are not provided with quick actuating closures (see UG-35) and that do not exceed the following volume and pressure limits may be exempted from inspection by Inspectors, as defined in UG-91, provided that they comply in all other respects with the requirements of this Division:

(1) 5 cu ft (0.14 m³) in volume and 250 psi (1720 kPa) design pressure, or

(2) 1½ cu ft (0.04 m³) in volume and 600 psi (4140 kPa) design pressure

In an assembly of vessels, the limitations in (1) and (2) apply to each vessel and not the assembly as a whole. Vessels fabricated in accordance with this rule shall be marked with the "UM" symbol in Fig. UG-116, sketch (b), and with the data required in UG-116. Certificates of Compliance shall satisfy the requirements of UG-120(a).

GENERAL

U-2 GENERAL

(a) The user or his designated agent⁸ shall establish the design requirements for pressure vessels, taking into consideration factors associated with normal operation, and such other conditions as startup and shutdown.

Such consideration shall include but shall not be limited to, the following:

(1) the need for corrosion allowance beyond those specified by the rules of this Division (see UG-25);

(2) the definition of lethal services. For example, see UW-2(a).

(3) the need for postweld heat treatment beyond the requirements of this Division and dependent on service conditions;

(4) for pressure vessels in which steam is generated, or water is heated, [see U-1(g) and (h)] the need for piping, valves, instruments, and fittings to perform the functions covered by PG-59 through PG-61 of Section I.

PRESSURE RELIEF DEVICES

UG-125 GENERAL

(a) All pressure vessels within the Scope of this Division, irrespective of size or pressure, shall be provided³⁴ with protective devices in accordance with the requirements of UG-125 through UG-136.

(b) An unfired steam boiler, as defined in U-1(g), shall be equipped with pressure relief devices required by Section I insofar as they are applicable to the service of the particular installation.

(c) All pressure vessels other than unfired steam boilers shall be protected by a pressure-relieving device that shall prevent the pressure from rising more than 10% above the maximum allowable working pressure except as permitted in (1) and (2). (See UG-134 for pressure settings)

(1) When multiple pressure relieving devices are provided and set in accordance with UG-134(a), they

³⁴Safety devices need not be provided by the vessel manufacturer, but overpressure protection shall be provided prior to placing the vessel in service.

DEPT. OF INDUSTRY, LABOR & HUMAN RELATIONS 131
ILHR 42

UG-125-UG-126

SECTION VIII — DIVISION I

shall prevent the pressure from rising more than 16% above the maximum allowable working pressure.

(2) Where an additional hazard can be created by exposure of a pressure vessel to fire or other unexpected sources of external heat, supplemental pressure relieving devices shall be installed to protect against excessive pressure. Such supplemental pressure relieving devices shall be capable of preventing the pressure from rising more than 21% above the maximum allowable working pressure. The same pressure relieving devices may be used to satisfy the capacity requirements of (c) or (c)(1) and this paragraph provided the pressure setting requirements of UG-134(a) are met.

(3) Pressure relief devices, intended primarily for protection against exposure of a pressure vessel to fire or other unexpected sources of external heat installed on vessels having no permanent supply connection and used for storage at ambient temperatures of nonrefrigerated liquefied compressed gases,³⁵ are excluded from the requirements of (c)(1) and (c)(2), provided:

(a) the relief devices are capable of preventing the pressure from rising more than 20% above the maximum allowable working pressure of the vessels;

(b) the set pressure of these devices shall not exceed the maximum allowable working pressure of the vessels;

(c) the vessels have sufficient ullage to avoid a liquid full condition;

(d) the maximum allowable working pressure of the vessels on which these devices are installed is greater than the vapor pressure of the stored liquefied compressed gas at the maximum anticipated temperature³⁶ that the gas will reach under atmospheric conditions; and

(e) pressure relief valves used to satisfy these provisions also comply with the requirements of UG-129(a)(5), UG-131(c)(2), and UG-134(e)(2).

(d) Pressure relieving devices shall be constructed, located, and installed so that they are readily accessible for inspection and repair and so that they cannot be readily rendered inoperative (see Appendix M), and should be selected on the basis of their intended service.

(e) If a pressure indicating gage is provided to determine the vessel pressure at or near the set pressure of the relief device, one should be selected that is graduated with an upper limit that is neither

less than 1.25 times the set pressure of the relief device nor more than twice the maximum allowable working pressure of the vessel. Additional gages may be installed if desired.

(f) Pressure relief valves or nonreclosing pressure relief devices³⁷ may be used as protective devices. Nonreclosing pressure relief devices may be used either alone or, if applicable, in combination with safety or safety relief valves on vessels.

NOTE: Use of nonreclosing devices of some types may be advisable on vessels containing substances that may render a safety or safety relief valve inoperative, where a loss of valuable material by leakage should be avoided, or where contamination of the atmosphere by leakage of noxious fluids must be avoided. The use of rupture disk devices may also be advisable when very rapid rates of pressure rise may be encountered.

(g) Vessels that are to operate completely filled with liquid shall be equipped with liquid relief valves, unless otherwise protected against overpressure.

(h) The protective devices required in (a) need not be installed directly on a pressure vessel when the source of pressure is external to the vessel and is under such positive control that the pressure in the vessel cannot exceed the maximum allowable working pressure at the operating temperature except as permitted in (c) (see UG-98).

NOTE: Pressure reducing valves and similar mechanical or electrical control instruments, except for pilot operated valves as permitted in UG-126(b), are not considered as sufficiently positive in action to prevent excess pressures from being developed.

(i) Safety and safety relief valves for steam service shall meet the requirements of UG-131(b).

UG-126 PRESSURE RELIEF VALVES³⁸

(a) Safety, safety relief, and relief valves shall be of the direct spring loaded type.

(b) Pilot operated pressure relief valves may be used, provided that the pilot is self-actuated and the

³⁷A pressure relief valve is a pressure relief device which is designed to reclose and prevent the further flow of fluid after normal conditions have been restored. A nonreclosing pressure relief device is a pressure relief device designed to remain open after operation.

³⁸A safety valve is a pressure relief valve actuated by inlet static pressure and characterized by rapid opening or pop action. A relief valve is a pressure relief valve actuated by inlet static pressure which opens in proportion to the increase in pressure over the opening pressure. A safety relief valve is a pressure relief valve characterized by rapid opening or pop action, or by opening in proportion to the increase in pressure over the opening pressure, depending on application. A pilot operated pressure relief valve is a pressure relief valve in which the major relieving device is combined with and is controlled by a self-actuated auxiliary pressure relief valve.

³⁵For the purpose of these rules, gases are considered to be substances having a vapor pressure greater than 40 psia at 100°F (38°C)

³⁶Normally this temperature should not be less than 115°F (46°C).

main valve will open automatically at not over the set pressure and will discharge its full rated capacity if some essential part of the pilot should fail.

(c) The spring in a pressure relief valve in service for pressures up to and including 250 psi (1720 kPa) shall not be reset for any pressure more than 10% above or 10% below that for which the valve is marked. For higher pressures, the spring shall not be reset for any pressure more than 5% above or 5% below that for which the safety or relief valve is marked.

(d) The set pressure tolerances, plus or minus, of pressure relief valves shall not exceed 2 psi (13.8 kPa) for pressures up to and including 70 psi (483 kPa) and 3% for pressures above 70 psi (483 kPa).

UG-127 NONRECLOSING PRESSURE RELIEF DEVICES

(a) Rupture Disk Devices³⁹

(1) General

(a) Every rupture disk shall have a stamped bursting pressure within a manufacturing design range⁴⁰ at a specified disk temperature,⁴¹ shall be marked with a lot number, and shall be guaranteed by its manufacturer to burst within 5% (plus or minus) of its stamped bursting pressure at the coincident disk temperature.

(b) The stamped bursting pressure within the manufacturing design range at the coincident disk temperature shall be derived by one of the following methods. All the tests of disks for a given lot shall be made in a holder of the same form and dimensions as that with which the disk is to be used.

(1) At least two sample rupture disks from

each lot of rupture disks, made from the same materials and of the same size as those to be used, shall be burst to verify that the stamped bursting pressure falls within the manufacturing design range at the coincident disk temperature. At least one disk shall be burst at room temperature. The stamped rating at the specified disk temperature shall be the average of the bursts at coincident disk temperature.

(2) At least four sample rupture disks, but not less than 5%, from each lot of rupture disks, made from the same material and of the same size as those to be used, shall be burst at four different temperatures, distributed over the applicable temperature range for which the disks will be used. These data shall be used to establish a curve of bursting pressure versus temperature for the lot of disks. The stamped rating at the coincident disk temperature shall be interpolated from this curve.

(3) For pre-bulged, solid metal disks or graphite disks only, a curve of percentage ratio at temperatures other than ambient may be established as in (2) above, using one size of disk for each lot of material. At least four bursts at four different temperatures shall be used to establish the above curve over the applicable temperature range. At least two disks from each lot of disks, made from this lot of material and of the same size as those to be used, shall be burst at ambient temperature to establish the room temperature rating of the lot of disks.

The percent change of bursting pressure taken from the above curve shall be used to establish the stamped rating at the coincident disk temperature for the lot of disks.

(2) Capacity Rating

(a) The calculated capacity rating of a rupture disk device shall not exceed a value based on the applicable theoretical formula (see UG-131) for the various media multiplied by:

$$K = \text{Coefficient} = 0.62$$

The area A (square inches) in the theoretical formula shall be the minimum net area existing after disk burst.⁴²

(b) In lieu of the method of capacity rating in (a) above, a manufacturer may have the capacity of a given rupture disk device design certified for the K_D

³⁹A rupture disk device is a nonreclosing pressure relief device actuated by inlet static pressure and designed to function by the bursting of a pressure containing disk. A rupture disk is the pressure containing and pressure sensitive element of a rupture disk device. A rupture disk holder is the structure which encloses and clamps the rupture disk in position. Rupture disks may be designed in several configurations, such as plain flat, pre-bulged or reverse buckling, and may be made of either ductile or brittle material; rupture disk material is not required to conform to an ASME specification. The material of the rupture disk holder shall be listed in Section II and this Division.

⁴⁰The manufacturing design range is a range of pressure within which the average burst pressure of test disks must fall to be acceptable for a particular requirement as agreed upon between the rupture disk manufacturer and the user or his agent. The disk shall be marked at the average burst pressure of all test disks.

⁴¹The specified disk temperature supplied to the rupture disk manufacturer shall be the expected temperature of the disk when an emergency condition exists and the disk is expected to rupture.

⁴²The minimum net flow area is the calculated net area after a complete burst of the disk with appropriate allowance for any structural members which may reduce the net flow area through the rupture disk device. The net flow area for sizing purposes shall not exceed the nominal pipe size area of the rupture disk device.

coefficient in general accordance with the procedures of UG-131, as applicable.

(3) *Application of Rupture Disks*

(a) A rupture disk device may be used as the sole pressure relieving device on a vessel.

NOTE: When rupture disk devices are used, it is recommended that the design pressure of this device be determined above the intended operating pressure to provide sufficient margin between operating pressure and rupture disk bursting pressure to prevent premature failure of the rupture disk due to fatigue or creep.

Application of rupture disk devices to liquid service should be carefully evaluated to assure that the design of the rupture disk device and the dynamic energy of the system on which it is installed will result in sufficient opening of the rupture disk.

(b) A rupture disk device may be installed between a pressure relief valve⁴³ and the vessel provided:

(1) The combination of the spring loaded safety or safety relief valve and the rupture disk device is ample in capacity to meet the requirements of UG-133(a) and (b).

(2) The stamped capacity of a spring loaded safety or safety relief valve (nozzle type) when installed with a rupture disk device between the inlet of the valve and the vessel shall be multiplied by a factor of 0.80 of the rated relieving capacity of the valve alone, or alternatively, the capacity of such a combination shall be established in accordance with (3) below.

(3) The capacity of the combination of the rupture disk device and the spring loaded safety or safety relief valve may be established in accordance with the appropriate paragraphs of UG-132, Certification of Capacity of Safety and Safety Relief Valves in Combination with Nonreclosing Pressure Relief Devices.

(4) The space between a rupture disk device and a safety or safety relief valve shall be provided with a pressure gage, a try cock, free vent, or suitable telltale indicator. This arrangement permits detection of disk rupture or leakage.⁴⁴

(5) The opening (see footnote 42) provided through the rupture disk after burst is sufficient to permit a flow equal to the capacity of the valve (2)

and (3) above), and there is no chance of interference with proper functioning of the valve; but in no case shall this area be less than 80% of the area of the inlet of the valve unless the capacity and functioning of the specific combination of rupture disk and valve have been established by test in accordance with UG-132.

(c) A rupture disk device may be installed on the outlet side⁴⁵ of a spring loaded safety relief valve which is opened by direct action of the pressure in the vessel provided:

(1) The valve is so designed that it will not fail to open at its proper pressure setting regardless of any back pressure that can accumulate between the valve disk and the rupture disk. The space between the valve disk and the rupture disk shall be vented or drained to prevent accumulation of pressure due to a small amount of leakage from the valve.⁴⁶

(2) The valve is ample in capacity to meet the requirements of UG-133(a) and (b).

(3) The stamped bursting pressure of the rupture disk at the coincident disk temperature plus any pressure in the outlet piping shall not exceed the design pressure of the outlet portion of the safety or safety relief valve and any pipe or fitting between the valve and the rupture disk device. However, in no case shall the stamped bursting pressure of the rupture disk at the coincident operating temperature plus any pressure in the outlet piping exceed the maximum allowable working pressure of the vessel or the set pressure of the safety or safety relief valve.

(4) The opening provided through the rupture disk device after breakage is sufficient to permit a flow equal to the rated capacity of the attached safety or safety relief valve without exceeding the allowable overpressure.

(5) Any piping beyond the rupture disk cannot be obstructed by the rupture disk or fragment.

(6) The contents of the vessel are clean fluids, free from gumming or clogging matter, so that accumulation in the space between the valve inlet and

⁴³The use of a rupture disk device in series with the safety or safety relief valve is prohibited to minimize the loss by leakage through the valve of material from the vessel or other hazardous materials and where a rupture disk alone or disk located inlet side of the valve is impracticable, or to prevent corrosive gases from a common discharge line from reaching the valve interval.

⁴⁴Users are warned that an ordinary spring loaded safety relief valve will not open at its set pressure if back pressure builds up in the space between the valve and rupture disk. A specially designed valve is required, such as a dumpback valve or a valve equipped with a bellows above the disk.

the rupture disk (or in any other outlet that may be provided) will not clog the outlet.

(7) The bonnet of the safety relief valve shall be vented to prevent accumulation of pressure.

(b) *Breaking Pin Device*⁴⁷

(1) Breaking pin devices shall not be used as single devices but only in combination between the safety or safety relief valve and the vessel.

(2) The space between a breaking pin device and a safety or safety relief valve shall be provided with a pressure gage, a try cock, a free vent, or suitable telltale indicator. This arrangement permits detection of breaking pin device operation or leakage.

(3) Each breaking pin device shall have a rated pressure and temperature at which the pin will break. The breaking pin shall be identified to a lot number and shall be guaranteed by the manufacturer to break when the rated pressure, within the following tolerances, is applied to the device:

Rated Pressure, psi		Tolerance, Plus or Minus, psi
Minimum	Maximum	
30	150	5
151	375	10
276	375	15

(4) The rated pressure of the breaking pin plus the tolerance in psi (kPa) shall not exceed 105% of the maximum allowable working pressure of the vessel to which it is applied.

(5) The rated pressure at the coincident operating temperature⁴⁸ shall be verified by breaking two or more sample breaking pins from each lot of the same material and the same size as those to be used. The lot size shall not exceed 25. The test shall be made in a device of the same form and pressure dimensions as that in which the breaking pin is to be used.

(c) *Spring Loaded Nonreclosing Pressure Relief Device*

(1) A spring loaded nonreclosing pressure relief device, pressure actuated by means which permit the spring loaded portion of the device to open at the specified set pressure and remain open until manually reset, may be used provided the design of the spring loaded nonreclosing device is such that if the actuating

⁴⁷A *breaking pin device* is a nonreclosing pressure relief device actuated by inlet static pressure and designed to function by the breakage of a load-carrying section of a pin which supports a pressure containing member. A *breaking pin* is the load-carrying element of a breaking pin device. A *breaking pin housing* is the structure which encloses the breaking pin mechanism. The material of the housing shall be listed in Section II and in this Division.

⁴⁸The specified temperature supplied to the breaking pin manufacturer shall be the temperature of the breaking pin when an emergency condition exists and the pin is expected to break.

means fail, the device will achieve full opening at or below its set pressure. Such a device may not be used in combination with any other pressure relief device. The tolerance on opening point shall not exceed $\pm 5\%$.

(2) The calculated capacity rating of a spring loaded nonreclosing pressure relief device shall not exceed a value based on the applicable theoretical formula (see UG-131) for the various media, multiplied by: $K = \text{Coefficient} = 0.62$.

The area A (square inches) in the theoretical formula shall be the flow area through the minimum opening of the nonreclosing pressure relief device.

(3) In lieu of the method of capacity rating in (2) above, a manufacturer may have the capacity of a spring loaded nonreclosing pressure relief device design certified in general accordance with the procedures of UG-131, as applicable.

UG-128 LIQUID RELIEF VALVES

Any liquid relief valve used shall be at least $\frac{1}{2}$ in. iron pipe size.

UG-129 MARKING

(a) *Safety, Safety Relief, and Pilot Operated Pressure Relief Valves.* Each safety, safety relief, and pilot operated valve $\frac{1}{2}$ in. pipe size and larger shall be plainly marked by the manufacturer or assembler with the required data in such a way that the marking will not be obliterated in service. The marking may be placed on the valve or on a plate or plates securely fastened to the valve. The Code symbol shall be stamped on the valve or nameplate, but the other required data may be stamped, etched, impressed, or cast on the valve or nameplate. The marking shall include the following:

(1) the name or identifying trademark of the manufacturer;

(2) manufacturer's design or type number;

(3) size _____ in. (the pipe size of the valve inlet);

(4) set pressure _____ psi;

(5) capacity _____ cu ft/min of air (60°F and 14.7 psia). Valves that are capacity certified in accordance with UG-131(c)(2) shall also be marked "At 20% OP"

(6) capacity _____ lb/hr of saturated steam for valves certified on steam or complying with UG-131(b);

NOTE. In addition, the manufacturer may indicate the capacity in other fluids (see Appendix I.).

DEPT. OF INDUSTRY, LABOR & HUMAN RELATIONS 135
ILHR 42

UG-129-UG-130

SECTION VIII — DIVISION 1



FIG. UG-129 OFFICIAL SYMBOL
FOR STAMP TO DENOTE THE
AMERICAN SOCIETY OF
MECHANICAL ENGINEERS'
STANDARD

(7) year built, or alternatively, a coding may be marked on the valve such that the valve manufacturer can identify the year built.

(8) ASME Symbol as shown in Fig. UG-129.

Valves smaller than $\frac{1}{2}$ in. pipe size are exempt from requirements (3), (5), and (6). Requirements (1), (2), (4), (7), and (8) may be marked on tags attached by wire, adhesive, or other means suitable for the service conditions.

(b) Safety and safety relief valves certified for a steam discharging capacity under the provisions of Section I and bearing the official Code symbol stamp of Section I for safety valves may be used on pressure vessels. The rated capacity in terms of other fluids shall be determined by the method of conversion given in Appendix 11. [See UG-131(h).]

(c) Pressure Relief Valves in Combination with Rupture Disk Devices. Pressure relief valves in combination with rupture disk devices shall be marked with the capacity established in accordance with UG-127(a)(3)(b)(2) or UG-127(a)(3)(b)(3), in addition to the marking of UG-129(a) and UG-129(f). The marking may be placed on the valve or on a plate or plates securely fastened to the valve. The marking shall include the following:

(1) A combination with capacity certified per UG-127(a)(3)(b)(2) shall be marked, prior to installation, as follows:

(a) capacity of combination _____ lb of saturated steam/hr or _____ cu ft of air/min (60°F and 14.7 psia)

(2) A combination with capacity certified per UG-127(a)(3)(b)(3) shall be marked by the responsible manufacturer, as follows:

(a) name of manufacturer of valve

(b) design or type number of valve

(c) name of manufacturer of rupture disk device

(d) design or type number of rupture disk device

(e) capacity of combination _____ lb of saturated steam/hr or _____ cu ft of air/min (60°F and 14.7 psia)

(d) Pressure Relief Valves in Combination with Breaking Pin Devices. Pressure relief valves in combi-

nation with breaking pin devices shall be marked in accordance with UG-129(a). In addition, the rated pressure shall be marked on the breaking pin and the breaking pin housing.

(e) Liquid Relief Valves. Each liquid relief valve shall be marked with the following data:

(1) name or identifying trademark of the manufacturer

(2) manufacturer's design or type number

(3) size _____ in. (pipe size of inlet)

(4) set pressure _____ psi

(5) relieving capacity _____ gal of water/min at 70°F

(f) Rupture Disk Devices. Every rupture disk shall be plainly marked by the manufacturer in such a way that the marking will not be obliterated in service. The rupture disk marking may be placed on the flange of the disk or on a metal tab permanently attached thereto.⁴⁹ The marking shall include the following:

(1) the name or identifying trademark of the manufacturer

(2) manufacturer's design or type number

(3) lot number

(4) size _____ in.,

(5) stamped bursting pressure _____ psi

(6) coincident disk temperature _____ °F

(7) capacity _____ lb of saturated steam/hr, or _____ cu ft of air/min (60°F and 14.7 psia)

NOTE: In addition, the manufacturer may indicate the capacity in other fluids (see Appendix 11).

Items (1), (2), and (4) shall also be marked on the rupture disk holder.

(g) Spring Loaded Nonreclosing Pressure Relief Devices. Spring loaded nonreclosing pressure relief devices shall be marked in accordance with UG-129(a) except that the Code symbol stamp is to be applied only when the capacity has been established and certified in accordance with UG-127(c)(3) and all other requirements of UG-130 have been met.

SECTION VIII — DIVISION .

exposure to fire or other sources of external heat, shall have a relieving capacity sufficient to prevent the pressure from rising more than 21% above the maximum allowable working pressure of the vessel when all pressure relieving devices are blowing.

(c) Vessels connected together by a system of adequate piping not containing valves which can isolate any vessel may be considered as one unit in figuring the required relieving capacity of pressure relieving safety devices to be furnished.

(d) Heat exchangers and similar vessels shall be protected with a relieving device of sufficient capacity to avoid overpressure in case of an internal failure.

(e) The official rated capacity of a pressure relieving safety device shall be that which is stamped on the device and guaranteed by the manufacturer.

(f) The rated pressure relieving capacity of a pressure relief valve for other than steam or air shall be determined by the method of conversion given in Appendix 11.

(g) To prorate the relieving capacity at any relieving pressure greater than $1.10p$, as permitted under UG-125, a multiplier may be applied to the official relieving capacity of a pressure relieving device as follows:

$$\frac{P + 14.7}{1.10p + 14.7}$$

where

P = relieving pressure, psig
 p = set pressure, psig

UG-134 PRESSURE SETTING OF PRESSURE RELIEF DEVICES

(a) When a single pressure-relieving device is used, it shall be set to operate⁵⁵ at a pressure not exceeding the maximum allowable working pressure of the vessel. When the required capacity is provided in more than one pressure-relieving device, only one device need be set at or below the maximum allowable working pressure, and the additional devices may be set to open at higher pressures but in no case at a pressure higher than 105% of the maximum allowable working pressure, except as provided in (b).

(b) Protective devices permitted in UG-125(c)(2) as protection against excessive pressure caused by expo-

⁵⁵Set to operate means the set pressure of a pressure relief valve or a spring loaded nonreclosing device; the bursting pressure of a rupture disk device; or, the breaking pressure of a breaking pin device.

UG-133 DETERMINATION OF PRESSURE RELIEVING REQUIREMENTS

(a) Except as permitted in (b), the aggregate capacity of the pressure-relieving devices connected to any vessel or system of vessels for the release of a liquid, air, steam, or other vapor shall be sufficient to carry off the maximum quantity that can be generated or supplied to the attached equipment without permitting a rise in pressure within the vessel of more than 16% above the maximum allowable working pressure when the pressure-relieving devices are blowing.

(b) Protective devices as permitted in UG-125(c)(2), as protection against excessive pressure caused by

DEPT. OF INDUSTRY, LABOR & HUMAN RELATIONS 137
ILHR 42

PART UG — GENERAL REQUIREMENTS

UG-134-UG-136

sure to fire or other sources of external heat shall be set to operate at a pressure not in excess of 110% of the maximum allowable working pressure of the vessel. If such a device is used to meet the requirements of both UG-125(c) and UG-125(c)(2), it shall be set to operate at not over the maximum allowable working pressure.

(c) If the operating conditions of a valve are changed so as to require another spring rated for a different pressure, the relief setting shall be adjusted by the manufacturer or by an individual certified by the manufacturer of that safety valve; the valve shall be remarked by either of them in conformance with UG-129.

(d) The pressure at which any device is set to operate shall include the effects of static head and constant back pressure.

(e)(1) The set pressure tolerance, plus or minus, or pressure relief valves shall not exceed 2 psi (13.8 kPa) for pressures up to and including 70 psi (483 kPa) and 3% for pressures above 70 psi (483 kPa), except as covered in (e)(2).

(2) The set pressure tolerance of pressure relief valves which comply with UG-125(c)(3) shall be within -0%, +10%.

(e) There shall be no intervening stop valves between the vessel and its protective device or devices, or between the protective device or devices and the point of discharge, except:

(1) when these stop valves are so constructed or positively controlled that the closing of the maximum number of block valves possible at one time will not reduce the pressure relieving capacity provided by the unaffected relieving devices below the required relieving capacity; or

(2) under conditions set forth in Appendix M.

(f) The safety devices on all vessels shall be so installed that their proper functioning will not be hindered by the nature of the vessel's contents

(g) Discharge lines from pressure relieving safety devices shall be designed to facilitate drainage or shall be fitted with drains to prevent liquid from lodging in the discharge side of the safety device, and such lines shall lead to a safe place of discharge. The size of the discharge lines shall be such that any pressure that may exist or develop will not reduce the relieving capacity of the relieving devices below that required to properly protect the vessel. [See UG-136(a) (8) and Appendix M.]

UG-135 INSTALLATION

(a) Safety, safety relief and pilot operated pressure relief valves, and nonreclosing pressure relief devices shall be connected to the vessel in the vapor space above any contained liquid or to piping connected to the vapor space in the vessel which is to be protected.

(b) The opening through all pipe and fittings between a pressure vessel and its pressure-relieving device shall have at least the area of the pressure-relieving device inlet, and the flow characteristics of this upstream system shall be such that the pressure drop will not reduce the relieving capacity below that required or adversely affect the proper operation of the pressure-relieving device. The opening in the vessel wall shall be designed to provide direct and unobstructed flow between the vessel and its pressure-relieving device.

(c) When two or more required pressure-relieving devices are placed on one connection, the inlet internal cross-sectional area of this connection shall be at least equal to the combined inlet areas of the safety devices connected to it, and the flow characteristics of the upstream system shall satisfy the requirements of (b).

(d) Liquid relief valves shall be connected below the normal liquid level.

...the provisions of this code shall be construed to conform to the intent and purpose of the code, and to the public interest, and to the best interests of the people of the state.

...the provisions of this code shall be construed to conform to the intent and purpose of the code, and to the public interest, and to the best interests of the people of the state.

EXERPTS FROM:

...the provisions of this code shall be construed to conform to the intent and purpose of the code, and to the public interest, and to the best interests of the people of the state.

...the provisions of this code shall be construed to conform to the intent and purpose of the code, and to the public interest, and to the best interests of the people of the state.

...the provisions of this code shall be construed to conform to the intent and purpose of the code, and to the public interest, and to the best interests of the people of the state.

...the provisions of this code shall be construed to conform to the intent and purpose of the code, and to the public interest, and to the best interests of the people of the state.

...the provisions of this code shall be construed to conform to the intent and purpose of the code, and to the public interest, and to the best interests of the people of the state.

...the provisions of this code shall be construed to conform to the intent and purpose of the code, and to the public interest, and to the best interests of the people of the state.

ASME BOILER AND PRESSURE VESSEL CODE

POWER PIPING

ANSI/ASME B31.1

1980 EDITION

...the provisions of this code shall be construed to conform to the intent and purpose of the code, and to the public interest, and to the best interests of the people of the state.

...the provisions of this code shall be construed to conform to the intent and purpose of the code, and to the public interest, and to the best interests of the people of the state.

FOREWORD

The general *philosophy* underlying this Power Piping Code is to parallel those provisions of Section I, Power Boilers, of the ASME Boiler and Pressure Vessel Code, as they can be applied to power piping systems. The Allowable Stress Values for power piping are generally consistent with those assigned for power boilers. This Code is more conservative than some other piping codes, reflecting the need for long service life and maximum reliability in power plant installations.

The Power Piping Code as currently written does not differentiate between the design, fabrication, and erection requirements for *critical and noncritical piping systems*, except for certain stress calculations and mandatory nondestructive tests of welds for heavy wall, high temperature applications. *The problem involved* is to try to reach agreement on how to evaluate criticality, and to avoid the inference that noncritical systems do not require competence in design, fabrication, and erection. Some day such levels of quality may be definable, so that the need for the many different piping codes will be overcome.

There are many instances where the Code serves to *warn a designer*, fabricator, or erector against possible pitfalls; but the Code is *not a handbook*, and cannot substitute for education, experience, and sound engineering judgment.

The Code *never intentionally puts a ceiling limit on conservatism*. A designer is free to specify more rigid requirements as he feels they may be justified. *Conversely, a designer who is capable of a more rigorous analysis than is specified in the Code may justify a less conservative design*, and still satisfy the basic intent of the Code.

The Power Piping Committee strives to keep abreast of the current technological improvements in new materials, fabrication practices, and testing techniques; and endeavors to keep the Code updated to permit the use of acceptable new developments.

INTRODUCTION

The Code for Pressure Piping, B31, consists of a number of Sections, which collectively constitute the Code. Hereinafter in this Introduction and in the text of this Code Section B31.1, when the word "Code" is used without identification to another specific Code Section, it means this Code Section.

The Code for Pressure Piping sets forth engineering requirements deemed necessary for safe design and construction of piping systems. While safety is the basic consideration of this Code, this factor alone will not necessarily govern the final specifications for any pressure piping system. The designer is cautioned that the Code is not a design handbook. The Code does not do away with the need for the engineer or competent engineering judgment.

The Code contains basic reference data and formulas necessary for design. It is intended to state these requirements in terms of basic design principles to the fullest possible extent, supplemented with specific requirements where necessary to obtain uniform interpretation of principle. It contains prohibitions in areas where practices or designs are known to be unsafe. In other areas the Code contains warnings or "flags" where caution is known to be necessary, but where it is felt that a direct prohibition would be unwise.

The Code includes:

(1) material specifications and component standards which have been accepted for Code usage;

(2) the designation of proper dimensional standards for the elements comprising piping systems;

(3) requirements for the design of component parts and assembled units, including necessary pipe supporting elements;

(4) requirements for the evaluation and limitation of stresses, reactions, and movements associated with pressure, temperature, and external forces;

(5) requirements for the fabrication, assembly, and erection of piping systems.

(6) requirements for testing and inspecting of elements before assembly or erection and of the completed systems after erection.

The components of piping systems shall comply with the Specifications and Standards listed in the Code. Compliance with this Code requires that fundamental principles be followed and that materials or practices not specifically approved under this Code, but which are not prohibited by the Code, be qualified for use as set forth in the applicable chapters of the Code.

The specific design requirements of the Code usually revolve around a simplified engineering approach to a subject. It is intended that a designer capable of applying more complete and rigorous analysis to special or unusual problems shall have latitude in the development of such designs and the evaluation of complex or combined stresses. In such cases the designer is responsible for demonstrating the validity of his approach.

This Code shall not be retroactive, or construed as applying to piping systems erected before the date of issuance. After code revisions are approved by ASME and accepted by ANSI, they may be used by agreement between contracting parties beginning with the date of issuance shown on the document title page. Revisions become mandatory as minimum requirements six months after date of issuance except for piping installations or components contracted for or under construction prior to the end of the 6 month period.

Manufacturers and users of piping are cautioned against making use of revisions and cases that are less restrictive than former requirements without having assurance that they have been accepted by the proper authorities in the jurisdiction where the piping is to be installed.

Attention of users of the Code is directed to the fact that the numbering of the Divisions and the material thereunder may not be consecutive. Such discontinuity is recognized. It is not the result of editorial or printing errors. An attempt has

DEPT. OF INDUSTRY, LABOR & HUMAN RELATIONS 141
ILHR 42

been made, insofar as possible, to follow a uniform outline in the various Sections. Due to the fact that the complete outline may cover phases not applicable to a particular Section, the Code has been prepared with gaps in the numbering. It is believed that in this way, cross referencing between Sections is made easier and use of the Code is facilitated since the same subject, in general, appears under the same number and sub-number in all Sections.

This Code is under the direction of the ASME Code Committee for Pressure Piping, B31. The procedures of the Committee are accredited by the American National Standards Institute.

The Committee is a continuing one and is organized to keep the Code up to date in context and in step with the developments in materials, construction, and usage. Revisions are issued periodically. New editions are published at three year intervals.

The Committee has established an orderly procedure to consider requests for interpretations and revisions of Code requirements. In order to receive consideration, inquiries shall be in writing and must give full particulars.

When an approved reply to an inquiry involves a change in Code requirements, the ruling is made public through the issuance of a "Case." This is published in *Mechanical Engineering*. A "Case Interpretation and Revision" service is maintained for the benefit of all who use the Code. Suggestions for revisions may originate within the Committee itself or from anyone outside the Committee.

All requests for interpretations or suggestions for revisions should be addressed to the Secretary, ASME Code Committee for Pressure Piping in care of The American Society of Mechanical Engineers, United Engineering Center, 345 East 47th Street, New York, N.Y. 10017.

100 GENERAL

This Power Piping Code is one of several Sections of the American Society of Mechanical Engineers Code for Pressure Piping, B31. This Section is published as a separate document for convenience.

Standards and Specifications specifically incorporated by reference into this Code are shown in Table 126.1. It is not considered practical to refer to a dated edition of each of the Standards and Specifications in this Code. Instead, the dated edition references are included in an Addendum which will be revised twice yearly.

100.1 Scope

100.1.1 This Code prescribes minimum requirements for the design, materials, fabrication, erection, test and inspection of power and auxiliary service piping systems for electric generation stations; industrial and institutional plants; central and district heating plants; and district heating systems, both on the property of and within the buildings of the users.

Piping as used in this Code includes pipe, flanges, bolting, gaskets, valves, relief devices, fittings, and the pressure containing parts of other piping components. It also includes hangers and supports and other equipment items necessary to prevent overstressing the pressure containing parts.

Rules governing piping for miscellaneous appurtenances, such as water columns, remote water level indicators, pressure gages, gage glasses, etc., are included within the scope of this Code, but the requirements for boiler appurtenances shall be in accordance with Section I of the ASME Boiler and Pressure Vessel Code, Para. PG-60.

The users of this Code are advised that in some areas legislation may establish governmental jurisdiction over the subject matter covered by this Code. However, any such legal requirement shall not relieve the owner of his inspection responsibilities specified in Para. 136.1.

PART 6 SYSTEMS**122 DESIGN REQUIREMENTS PERTAINING TO SPECIFIC PIPING SYSTEMS****122.1 Boiler External Piping; in Accordance With Para. 100.1.2(A) — Steam, Feedwater, Blowoff, and Drain Piping**

122.1.1 General. The minimum pressure and temperature and other special requirements to be used in the design for steam, feedwater, blowoff, and drain piping from the boiler to the valve or valves required by Para. 122.1 defined in Para. 100.1.2(A) shall be as specified in the following paragraphs.

(A) Expected maximum sustained conditions at pressure and temperature are intended to be selected sufficiently in excess of any expected operating conditions, not necessarily continuous, to permit satisfactory operation without operation of the overpressure protection devices.

(B) In a forced flow steam generator with no fixed steam and water line, it is permissible to design the external piping, valves and fittings attached to the pressure parts for different pressure levels along the path through the steam generator of water-steam flow. The value of P to be used for the external piping, valves, and fittings shall not be less than that required for the expected maximum sustained conditions of pressure and temperature to which the abutted pressure part is subjected except when one or more of the overprotection devices covered by Para. PG-67.4 of Section I of the ASME Boiler and Pressure Vessel Code is in operation. The steam piping shall comply with the requirements for the maximum sustained conditions as used in this paragraph, or for the design throttle pressure plus 5%, whichever is greater. "Expected maximum sustained conditions of pressure and temperature" are intended to be selected sufficiently in excess of any expected operating conditions, not necessarily continuous, to permit satisfactory boiler operation without operation of the overpressure protection devices.

(C) Provision shall be made for the expansion and contraction of piping connected to boilers to limit forces and moments transmitted to the boiler, by providing substantial anchorage at suitable points, so that there shall be no undue strain transmitted to the boiler. Steam reservoirs shall be used on steam mains when heavy pulsations of the steam currents cause vibration.

DEPT. OF INDUSTRY, LABOR & HUMAN RELATIONS 143
ILHR 42

AN AMERICAN NATIONAL STANDARD
POWER PIPING

ANSI/ASME B31.1-1980 EDITION
122.1.1-122.1.3

(D) Stresses due to hydrostatic head shall be taken into account. These effects include the weight, contents, and method of support.

(E) The allowable working pressure of a corrugated pipe shall be computed as for the original pipe from which the corrugated pipe is made, based on the dimensions of the straight uncorrugated sections. If the corrugations are thinned down in the process of manufacture, the thickness of such corrugations shall be used as the thickness of the pipe.

(F) Piping connected to the outlet of a boiler for any purpose shall be attached by:

(F.1) welding to a nozzle or socket welded fitting;

(F.2) threading into a tapped opening with a threaded fitting or valve at the other end;

(F.3) screwing each end into tapered flanges, fittings, or valves with or without rolling or peening;

(F.4) bolted joints including those of the Van Stone type;

(F.5) blowoff piping of firetube boilers shall be attached in accordance with Para. 122.1.1(F.2) if exposed to products of combustion or in accordance with Para. 122.1.1(F.2), (F.3), or (F.4) if not so exposed.

(G) Nonferrous pipe or tubes shall not exceed 3 in. NPS in diameter.

(H) American National Standard slip-on flanges not exceeding 4 in. NPS may be attached to piping or boiler nozzles by double fillet welds provided the throats of fillet welds are not less than 0.7 times the thickness of the part to which the flange is attached.

(I) Hub-type flanges shall not be cut from plate material.

(J) American National Standard socket welded flanges may be used in piping or boiler nozzles provided the dimensions do not exceed 3 in. NPS for Class 600 and lower and 2½ in. NPS in Class 900 and 1500.

122.1.2 Steam Piping

(A) The value of P to be used in the formulas in Para. 104 shall be as follows.

(A.1) For steam piping connected to the steam drum or to the superheater inlet header up to the first stop valve in each connection, the value of P shall not be less than the lowest pressure at which any drum safety valve is set to blow, and the S value shall not exceed that permitted for the corresponding saturated steam temperature.

(A.2) For steam piping connected to the superheater outlet header up to the first stop valve in each connection, the value of P , except as otherwise provided in Para. 122.1.2(A.4) shall be not less than the

lowest pressure at which any safety valve on the superheater is set to blow, or not less than 85% of the lowest pressure at which any drum safety valve is set to blow, whichever is greater, and the S value for the material used shall not exceed that permitted for the expected steam temperature.

(A.3) For steam piping between the first stop valve and the second valve, when one is required by Para. 122.1.7, the value of P shall be not less than the expected operating pressure or 85% of the lowest pressure at which any drum safety valve is set to blow, whichever is greater, and the S value for the material used shall not exceed that permitted for the expected steam temperature.

(A.4) For boilers installed on the unit system (i.e., one boiler and one turbine or other prime mover) and provided with automatic combustion control equipment responsive to steam header pressure, the value of P for the steam piping shall be not less than the design pressure at the throttle inlet plus 5%, or not less than 85% of the lowest pressure at which any drum safety valve is set to blow, or not less than the expected maximum sustained pressure at any point in the piping system, whichever is greater, and the S value for the material used shall not exceed that permitted for the expected steam temperature at the super-heater outlet. For forced-flow steam generators with no fixed steam and waterline, the value of P shall also be no less than the expected maximum sustained conditions.

(A.5) The value of P shall not be taken at less than 100 psig (700 kPag) for any condition of service or material.

(B) Figure PG-59-1 of Section I of the ASME Boiler and Pressure Vessel Code illustrates a typical form of flange for use on boiler shells for passing through piping, such as feed, surface-blowoff connections, etc., and which permits the pipes being threaded in solid from both sides in addition to the reinforcing of the opening of the shell. The pipes shall be attached as provided in Para. 122.1.1(G). In these and other types of boilers where both internal and external pipes making a continuous passage are employed, the boiler bushing or its equivalent shall be used.

122.1.3 Feedwater Piping

(A) The value of P to be used in the formulas in Para. 104 shall be as follows.

(A.1) For piping from the boiler to and including the required stop valve and the check valve, the value of P except as permitted in Para. 122.1.3(A.7) shall exceed the maximum allowable working pressure of the

boiler by either 25% or 225 psi (1550 kPa), whichever is the lesser. For an installation with an integral economizer without valves between the boiler and economizer, this paragraph shall apply only to the piping from the economizer inlet header to and including the required stop valve and the check valve.

(A.2) For piping between the required check valve and the globe or regulating valve, when required by Para. 122.1.7(B), and including any bypass piping up to the shutoff valves in the bypass, the value of P shall be not less than the pressure required to feed the boiler.

(A.3) The S value used, except as permitted in Para. 122.1.3(A.7), shall not exceed that permitted for the temperature of saturated steam at the maximum allowable working pressure of the boiler.

(A.4) The value of P in the formula shall not be taken at less than 100 psig (700 kPag) for any condition of service or material, and shall never be less than the pressure required to feed the boiler.

(A.5) While the thickness given by the formula is theoretically ample to take care of both bursting pressure and material removed in threading, when steel pipe is threaded and used for feedwater piping under pressure in excess of 100 psig (700 kPag) with a water temperature of 220°F (105°C) and over, it shall be seamless of a quality at least equal to ASTM A 53 or A 106 and of a weight at least equal to Schedule 80 pipe in order to furnish added mechanical strength.

(A.6) When threaded brass or copper pipe is used for these services and pressure-temperature conditions, it shall be in accordance with pressure and temperature classification permitted for these materials by other paragraphs of this Code and shall have a wall thickness at least equal to that required for steel pipe of a corresponding nominal size.

(A.7) In a forced flow steam generator with no fixed steam and water line, the value of P for feedwater piping from the boiler to and including the required stop valve may be in accordance with the requirements of Para. 122.1.1(B).

(A.8) For boilers having a water-heating surface of not more than 100 sq ft (9.3 m²), the feed piping and connection to the boiler shall not be smaller than ½ in. NPS. For boilers having a water-heating surface more than 100 sq ft (9.3 m²), the feed piping and connection to the boiler shall not be less than ¾ in. NPS.

122.1.4 Blowoff Piping

(A) Blowoff piping is defined as a pipe connected to a boiler and provided with valves or cocks through which the water in the boiler may be blown out under

pressure, excepting drains such as are used on water columns, gage glasses, or piping to feed-water regulators, etc., used for the purpose of determining the operating condition of such equipment. Piping connections used primarily for continuous operation, such as deconcentrators on continuous blowdown systems, are not classed as blowoffs; but their pipe connections and all fittings up to and including the first shutoff valve shall be equal at least to the pressure requirements for the lowest set pressure of any safety valve on the boiler drum and with the corresponding saturated steam temperature.

(B) Blowoff piping systems from water spaces of a boiler, up to and including the blowoff valve(s) or cock(s) shall be designed in accordance with the following.

(B.1) The value of P to be used in the formulas in Para. 104 shall exceed the maximum allowable working pressure of the boiler by either 25% or 225 psi (1550 kPa) whichever is less, but shall not be less than 100 psig (700 kPag).

(B.2) The allowable stress value for the piping materials shall not exceed that permitted for the temperature of saturated steam at the maximum allowable working pressure of the boiler.

(B.3) All pipe shall be steel. Galvanized wrought iron and galvanized steel pipe and fittings shall not be used for blowoff piping. When the value of P does not exceed 100 psig (700 kPag), the fittings shall be bronze, cast iron, malleable iron, ductile iron, or steel. When the value of P exceeds 100 psig (700 kPag), the fittings shall be steel, and the thickness of pipe and fittings shall not be less than that of Schedule 80 pipe.

(B.4) When the value of P does not exceed 200 psig (1400 kPag), the valves or cocks shall be bronze, cast iron, ductile iron, or steel. For values of P higher than 100 psig (700 kPag) but not exceeding 200 psig (1400 kPag), the valves or cocks shall, if of cast iron, be equal at least to the requirements of the American National Standard for Class 250 as given in Table 126.1 and if of bronze, steel, or ductile iron construction, shall be equal to the requirements of the Standards as given in Table 126.1 or Para. 123.2.6.

(B.5) For values of P higher than 200 psig (1400 kPag), the valves or cocks shall be of steel construction equal at least to the requirements of the American National Standard for Class 300 and shall conform to the required American National Standards in Table 126.1.

(C) Each boiler except forced-flow steam generators with no fixed steam and water line, and high temperature water boilers shall have a bottom blowoff pipe

DEPT. OF INDUSTRY, LABOR & HUMAN RELATIONS 145
ILHR 42

AN AMERICAN NATIONAL STANDARD
POWER PIPING

ANSI-ASME B31.1-1980 EDITION
122.1.4-122.1.7

fitted with a valve or cock in direct connection with the lowest water space practicable.

(D) All water walls and water screens which do not drain back into the boiler, and all integral economizers shall be equipped with blowoff valves or cocks conforming to the requirements of Para. 122.1.7(C) or with drain valves conforming to Para. 122.1.5.

(E) The minimum size of pipe and fittings shall be 1 in., and the maximum size shall be 2½ in. The following exceptions are permitted.

(E.1) For miniature boilers, the exception permitted by Part PBM of Section I of the ASME Boiler and Pressure Vessel Code applies.

(E.2) On boilers with 100 sq ft (9.3 m²) of heating surface or less, the minimum size of pipe and fittings may be ¾ in.

(F) The bottom blowoff pipes of traction and/or portable boilers shall have at least one slow or quick-opening blowoff valve or cock conforming to the requirements of Para. 122.1.7(C.3).

(G) The blowoff piping beyond the blowoff valves described in Para. 122.1.4(B) is classified as nonboiler external piping. Its requirements are given in Para. 122.2.

122.1.5 Boiler Drains

(A) Ample drains shall be provided, where required, to permit complete drainage of all piping, superheaters, waterwalls, water screens, integral economizers, high temperature water boilers, and all other boiler components in which water may collect. Drain or blowoff valves or cocks shall be provided as necessary. All drain lines, including pipe, fittings, and valves, shall comply with the requirements for steam piping or water piping according to the service.

(A.1) Each superheater shall be equipped with, at least one drain so located as to most effectively provide for the proper operation of the apparatus.

(A.2) Each high temperature water boiler shall have a bottom drain connection 1 in. minimum pipe size, fitted with a valve or cock in direct connection with the lowest water space practicable.

(B) When the valve or valves for waterwalls, water screens, and integral economizers in Paras. 122.1.5(A) and 122.1.4(D) are not intended for blowoff purposes but are intended for use only as a drain valve when the boiler is not under pressure, a single shutoff valve is acceptable, provided it is a type that can be locked in the closed position, or provided a blank is inserted in a suitable flanged and bolted connection located on the downstream side of the valve. When such a single valve is used, it need not be de-

signed specifically for blowoff service but shall be adequate for the pressure and temperature conditions at which the boiler operates.

122.1.6 Boiler External Piping — Miscellaneous Systems

(A) Materials, design, fabrication, examination, and erection of piping for miscellaneous accessories, such as water level indicators, water columns, gage cocks, and pressure gages, shall be in accordance with the applicable sections of this Code.

(B) The value of *P* to be used in the Formulas in Para. 104 shall be not less than the maximum allowable working pressure of the boiler except as provided by Para. 122.1.4(B).

(C) Valve requirements for water level indicators or water columns, special gage glass and gage cock requirements, minimum line sizes, and special piping configurations required specifically for cleaning, access, or reliability shall be in accordance with Para. PG-60 of Section I of the ASME Boiler and Pressure Vessel Code.

122.1.7 Valves and Fittings. The minimum pressure and temperature rating for all valves and fittings in steam, feedwater, blowoff, and miscellaneous piping shall be equal to the pressure and temperature specified for the connected piping on the side that has the higher pressure, except that in no case shall the pressure be less than 100 psig (700 kPag), and for pressures not exceeding 100 psig (700 kPag) in feedwater and blowoff service, the valves and fittings shall be equal at least to the requirements of the American National Standards for Class 125 cast iron or Class 150 steel.

(A) Steam Stop Valves

(A.1) Each boiler discharge outlet, except safety valve or safety relief valves, or reheater inlet and outlet connections shall be fitted with a stop valve located at an accessible point in the steam-delivery line and as near the boiler nozzle as is convenient and practicable. When such outlets are over 2 in. NPS, the valve or valves used on the connection shall be of the outside-screw-and-yoke rising-stem type so as to indicate from a distance by the position of its stem whether it is closed or open, and the wheel may be carried either on the yoke or attached to the stem. A plug-cock-type valve may be used provided the plug is held in place by a guard or gland, the valve is equipped to indicate from a distance whether it is closed or open, and the valve is equipped with a slow-opening mechanism. In the case of a single boiler and prime mover installation, the stop valve required herein may be omitted provided the prime mover throttle valve is equipped with an indica-

tor to show whether the valve is open or closed and is designed to withstand the required hydrostatic pressure test of the boiler.

(A.2) When boilers are connected to a common header, the connection from each boiler having a man-hole opening shall be fitted with two stop valves having an ample free-blow drain between them. The discharge of this drain shall be visible to the operator while manipulating the valve. The stop valves shall consist preferably of one automatic nonreturn valve (set next to the boiler) and a second valve of the outside-screw-and-yoke type or two valves of the outside-screw-and-yoke type shall be used.

(A.3) When a second stop valve or valves is required, it shall have a pressure rating at least equal to that required for the expected steam temperature and pressure at the valve, or the pressure rating at least equal to 85% of the lowest set pressure of any safety valve on the boiler drum and for the expected temperature of the steam at the valve, whichever is greater.

(A.4) All valves and fittings on steam lines shall have a pressure rating of at least 100 psig (700 kPag) in accordance with the applicable American National Standard.

(B) Feedwater Valves

(B.1) Except for high temperature water boilers complying with the requirements of Para. 122.1.7(B.6) and for forced-flow steam generators with no fixed steam and water line complying with the requirements of Para. 122.1.7(B.7), the feed pipe shall be provided with a check valve near the boiler and a valve or cock [see Para. 122.1.7(C.5)] between the check valve and the boiler. When two or more boilers are fed from a common source, there shall also be a globe or regulating valve on the branch to each boiler located between the check valve and the source of supply. A typical arrangement is shown in Fig. 100.1.2(B). Wherever globe valves are used on feed piping, the inlet shall be under the disk of the valve. On single boiler-turbine unit installations the boiler feed shutoff valve may be located upstream from the boiler feed check valve.

(B.2) When the supply line to a boiler is divided into branch feed connections and all such connections are equipped with stop and check valves, the stop and check valves in the common source may be omitted.

(B.3) If a boiler is equipped with a duplicate feed arrangement, each such arrangement shall be equipped as required by these rules.

(B.4) A combination stop-and-check valve in which there is only one seat and disk, and a valve

stem is provided to close the valve when the stem is screwed down shall be considered only as a stop valve, and a check valve shall be installed as otherwise provided.

(B.5) Where an economizer or other feedwater-heating device is connected directly to the boiler without intervening valves, the feed valves and check valves required shall be placed on the inlet of the economizer or feedwater-heating device.

(B.6) The recirculating return line for a high temperature water boiler shall be provided with the same stop valve, or valves, required by (B.1) above for the main boiler outlet. The use of a check valve in the recirculating return line between the boiler and the required stop valve, or valves, is optional. A check valve shall not be a substitute for a stop valve.

(B.7) A forced-flow steam generator with no fixed steam and water line shall be provided with a feedwater stop valve or valves complying with requirements of 122.1.7(B.1) through (B.6) above. This stop valve and all piping between the valve and the boiler shall conform to the rules of this Code. A check valve near the boiler or feed stop valve, and within the scope of this Code, is not mandatory provided a check valve, having a pressure rating no less than the boiler inlet design pressure, is installed at the discharge of the boiler feed pump or elsewhere in the feedwater line between the feed pump and the feed stop valve.

(C) Blowoff Valves

(C.1) Straight-run globe valves of the ordinary type as shown in Fig. 122.1.7(C) sketch (1) and valves of such types that dams or pockets can exist for the collection of sediment shall not be used on such connections.

(C.2) Straightway Y-type globe valves as shown in Fig. 122.1.7(C) sketch (2) or angle valves may be used in vertical pipes, or they may be used in horizontal runs of piping provided they are so constructed or installed that the lowest edge of the opening through the seat is at least 25% of the inside diameter below the center line of the valve.

(C.3) The blowoff valve or valves and the pipe between them and the boiler shall be of the same size except where a larger pipe for the return of condensation is used, as provided in Para. 122.1.7(C.8).

(C.4) On all boilers, except those used for high temperature water, traction, and/or portable purposes, when the allowable working pressure exceeds 100 psig (700 kPag), each bottom blowoff pipe shall have two slow-opening valves, or one slow-opening valve and a

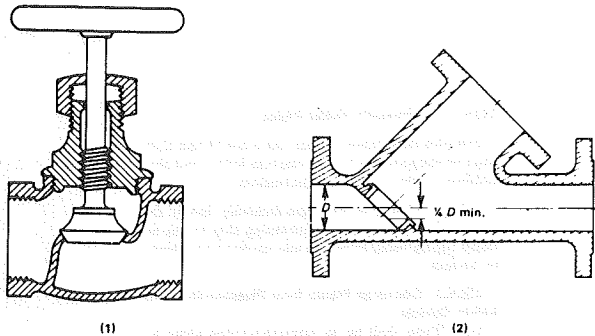

FIG. 122.1.7(C) TYPICAL GLOBE VALVES

quick-opening valve or a cock complying with the requirements of Paras. 122.1.4(A.6) and (A.7).

(C.5) If a blowoff cock is used, the plug shall be held in place by a guard or gland. The plug shall be distinctly marked in line with the passage.

(C.6) A slow-opening valve is a valve which requires at least five 360-deg. turns of the operating mechanism to change from full-closed to full-opened and vice versa.

(C.7) On a boiler having multiple blowoff pipes, a single master valve may be placed on the common blowoff pipe from the boiler, in which case only one valve on each individual blowoff is required. In such a case either the master valve or the individual valves or cocks shall be of the slow-opening type.

(C.8) Two independent slow-opening valves, or a slow-opening valve and a quick-opening valve or cock may be combined in one body and may be used provided the combined fitting is the equivalent of two independent slow-opening valves, or a slow-opening valve and a quick-opening valve or cock, and provided further that the failure of one to operate cannot affect the operation of the other.

(C.9) The bottom blowoff pipes of every traction and/or portable boiler shall have at least one slow-opening or quick-opening blowoff valve or cock conforming to the requirements of Para. 122.1.7(C.3).

(C.10) Only one blowoff valve, which shall be of a slow-opening type, is required on forced circulation and electric boilers having a normal water content not exceeding 100 gal (380 l).

(D) Safety Valves

(D.1) Safety valves, relief valves, and safety relief valves shall conform to the requirements of Paras. PG-67, PG-68, PG-69, PG-70, PG-71, and PG-72 of Section I of the ASME Boiler and Pressure Vessel Code.

122.6 Pressure Relief Piping

Pressure relief piping within the scope of this Code shall be supported to sustain reaction forces, and shall conform to the following requirements.

122.6.1 Piping to Pressure-Relieving Safety Devices. There shall be no intervening stop valves between piping being protected and its protective device or devices.

122.6.2 Discharge Piping from Pressure-Relieving Safety Devices

(A) There shall be no intervening stop valve between the protective device or devices and the point of discharge.

(B) When discharging directly to the atmosphere, discharge shall not impinge on other piping or equipment and shall be directed away from platforms and other areas used by personnel.

(C) It is recommended that individual discharge lines be used, but if two or more reliefs are combined, the discharge piping shall be designed with sufficient flow area to prevent blowout of steam or other fluids.

Sectional areas of a discharge pipe shall not be less than the full area of the valve outlets discharging thereunto and the discharge pipe shall be as short and straight as possible and so arranged as to avoid undue stresses on the valve or valves.

(D) Discharge lines from pressure-relieving safety devices within the scope of this Code shall be designed to facilitate drainage.

(E) When the umbrella or drip pan type of connection is used, the discharge piping shall be so designed as to prevent binding due to expansion movements.

(F) Drainage shall be provided to remove water collected above the safety valve seat.