

Chapter Comm 82

DESIGN, CONSTRUCTION, INSTALLATION SUPERVISION AND INSPECTION OF PLUMBING

Comm 82.01 Scope
Comm 82.03 Application

Subchapter I—Plumbing Principles and Definitions

Comm 82.10 Basic plumbing principles
Comm 82.11 Definitions

Subchapter II—Administration and Enforcement

Comm 82.20 Plan review and approval
Comm 82.21 Testing and maintenance

Subchapter III—Drain and Vent Systems

Comm 82.30 Sanitary drain systems
Comm 82.31 Vents and venting systems
Comm 82.32 Traps and direct fixture connections

Comm 82.33 Indirect and local waste piping
Comm 82.34 Interceptors and catch basins for special and industrial wastes
Comm 82.35 Cleanouts
Comm 82.36 Storm and clear water drain systems

Subchapter IV—Water Supply Systems

Comm 82.40 Water supply systems
Comm 82.41 Cross connection control

Subchapter V—Special Plumbing Installations

Comm 82.50 Health care related facilities
Comm 82.51 Mobile home sites and parks

Subchapter VI—Installation

Comm 82.60 Pipe hangers and supports

Note: Sections ILHR 82.01 to 82.25, 82.15 and 82.17 to 82.25 as they existed on February 28, 1985 were repealed and new sections ILHR 82.01 to 82.36 and 82.51 and 82.60 were created effective March 1, 1985. Chapter ILHR 82 was renumbered chapter Comm 82 under s. 13.93 (2m) (b) 1., Stats. and corrections made under s. 13.93 (2m) (b) 7., Stats., Register, February, 1997, No. 494.

Comm 82.01 Scope. The provisions of this chapter apply to the design, construction and installation of plumbing, including but not limited to sanitary and storm drainage, water supplies, storm water and sewage disposal for buildings.

Note: Chapter Comm 83 contains provisions for the siting, design, installation, inspection and maintenance of private sewage systems. Chapter Comm 84 contains provisions and standards for plumbing materials, plumbing fixtures and plumbing appliances.

History: Cr. Register, February, 1985, No. 350, eff. 3-1-85.

Comm 82.03 Application. The provisions of this chapter are not retroactive, unless specifically stated otherwise in the rule.

History: Cr. Register, February, 1985, No. 350, eff. 3-1-85.

Subchapter I— Plumbing Principles and Definitions

Comm 82.10 Basic plumbing principles. This chapter is founded upon certain basic principles of environmental sanitation and safety through properly designed, installed, and maintained plumbing systems. Some of the details of plumbing construction may vary, but the basic sanitary and safety principles desirable and necessary to protect the health of people are the same everywhere. As interpretations may be required, and as unforeseen situations arise which are not specifically addressed, the following principles shall be used to define the intent of this chapter.

(1) Plumbing in all buildings, public and private, intended for human occupancy, shall be installed and maintained in such a manner so as to protect the health, safety and welfare of the public or occupants.

(2) Every building intended for human occupancy shall be provided with an adequate, safe and potable water supply. A building located adjacent to a street in which there is a public water supply, shall be connected to the public water supply.

(3) Each dwelling unit connected to a private sewage system or public sewer shall have at least one water closet, one wash basin, one kitchen sink and one bathtub or shower to meet the basic requirements of sanitation and personal hygiene. All other structures for human occupancy shall be equipped with sanitary facilities in sufficient numbers as specified in chs. ILHR 50 to 64.

(4) Plumbing fixtures, appliances and appurtenances, whether existing or to be installed, shall be supplied with water in sufficient volume and at pressures adequate to enable them to function prop-

erly and efficiently at all times and without undue noise under normal conditions of use. Plumbing systems shall be designed and adjusted to use the minimum quantity of water consistent with proper performance and cleaning.

(5) Hot or tempered water shall be supplied to all plumbing fixtures which normally require hot or tempered water for proper use and function.

(6) Devices for heating water and storing it in pressure vessels or tanks shall be so designed and installed as to prevent dangers of explosion or overheating.

(7) Every building with installed plumbing fixtures and intended for human occupancy, located adjacent to a street in which there is public sewer service, shall be connected to the public sewer by means of individual connections or private interceptor mains.

(8) Where plumbing fixtures exist in a building which is not connected to a public sewer system, suitable provision shall be made for disposing of the building sewage by a method of sewage treatment or disposal satisfactory to the department and the governmental unit responsible for the regulation of private sewage systems.

(9) Drain systems shall be designed, constructed, and maintained to conduct the waste water or sewage quickly from the fixture to the place of disposal, with velocities which will prevent clogging, fouling and the depositing of solids, and shall have adequate cleanouts so arranged that the drain pipes may be readily cleaned.

(10) The drain systems shall be designed so that there is an adequate circulation of air in all pipes and no danger of siphonage, aspiration or forcing of trap seals under conditions of ordinary use.

(11) The piping of a plumbing system shall be of durable material, free from defective workmanship, and designed and constructed to give satisfactory service for its reasonable expected life.

(12) Plumbing fixtures shall be made of durable, smooth, non-absorbent and corrosion resistant material, and shall be free from concealed fouling surfaces.

(13) Proper protection shall be provided to prevent contamination of food, water, sterile goods and similar materials by backflow of sewage.

(14) All plumbing fixtures shall be installed to provide adequate spacing and accessibility for the intended use and for cleaning.

(15) All rooms in which water closets, urinals or similar fixtures are installed shall be provided with adequate lighting and proper ventilation.

Note: See ss. ILHR 52.53 to 52.55 for toilet rooms located in commercial and public buildings.

History: Cr. Register, February, 1985, No. 350, eff. 3-1-85; correction in (3) made under s. 13.93 (2m) (b) 7., Stats; am. (2), Register, August, 1991, No. 428, eff. 9-1-91; am. (3), Register, March, 1992, No. 435, eff. 4-1-92.

Comm 82.11 Definitions. In chs. Comm 82 and 84:

(1) "Accepted engineering practice" means a specification, standard, guideline or procedure in the field of construction or related thereto, generally recognized and accepted as authoritative.

(2) "Accessible" when applied to a fixture, appliance, pipe, fitting, valve or equipment, means having access thereto, but which first may require the removal of an access panel or similar obstruction.

(3) "Air-break" means a piping arrangement for a drain system where the wastes from a fixture, appliance, appurtenance or device discharge by means of indirect or local waste piping terminating in a receptor at a point below the flood level rim of the receptor and above the inlet of the trap serving the receptor.

(4) "Air-gap, drain system" means the unobstructed vertical distance through free atmosphere between the outlet of indirect or local waste piping and the flood level rim of the receptor into which it discharges.

(5) "Air-gap", in the water supply system, means the unobstructed vertical distance through the free atmosphere between the lowest opening from any pipe or faucet supplying water to a tank or plumbing fixture and the flood-level rim or spill level of the receptacle.

(6) "Alignment" means installed in a straight line, either horizontal, vertical or at a given angle.

(9) "Approved" means acceptable to the department.

(10) "Area drain" means a receptor designed to collect surface or storm waters from an open area.

(11) "Areawide water quality management plan" means those plans prepared by the department of natural resources, including those plans prepared by agencies designated by the governor under the authority of ch. 281 and s. 283.83, Stats., for the purpose of managing, protecting and enhancing groundwater and surface water of the state.

Note: See Appendix for further explanatory material.

(12) "Aspirator" means a fitting or device supplied with water or other fluid under positive pressure which passes through an integral orifice or constriction causing a vacuum.

(13) "Autopsy table" means a fixture or table used for post-mortem examination.

(14) "Backflow" means the unwanted reverse flow of liquids, solids or gases.

(16) "Back-pressure" means a pressure greater than the supply pressure which may cause backflow.

(17) "Backflow preventer with intermediate atmospheric vent" means a type of cross connection control device which consists of 2 independently acting check valves, internally force loaded to a normally closed position and separated by an intermediate chamber with a means for automatically venting to atmosphere, the venting means is internally force loaded to a normally open position.

(18) "Backsiphonage" means the creation of a backflow as a result of negative pressure.

(18m) "Back siphonage backflow vacuum breaker" means a type of cross connection control device which contains a check valve force-loaded closed and an air inlet vent valve force-loaded open to atmosphere, positioned downstream of the check valve, and located between and including 2 tightly closing shut-off valves and 2 test cocks.

(19) "Backwater valve" means a device designed to prevent the reverse flow of storm water or sewage into the drain system.
Note: Back vent, see "individual vent".

(20) "Ballcock" means a water supply valve opened or closed by means of a float or similar device used to supply water to a tank.

(21) "Bathroom group" means a water closet, lavatory and a bathtub or shower located together on the same floor level.

(22) "Battery of fixtures" means any group of 2 or more fixtures which discharge into the same horizontal branch drain.

(23) "Bedpan sterilizer" means a fixture used for sterilizing bedpans or urinals by direct application of steam, boiling water or chemicals.

(24) "Bedpan washer and sanitizer" means a fixture designed to wash bedpans and to flush the contents into the sanitary drain system and which may also provide for disinfecting utensils by scalding with steam or hot water.

(25) "Bedpan washer hose" means a device supplied with hot or cold water, or both, and located adjacent to a water closet or clinical sink to be used for cleansing bedpans.

(26) "Bell" means the portion of a pipe which is enlarged to receive the end of another pipe of the same diameter for the purpose of making a joint.

(27) "Boiler blow-off basin" means a vessel designed to receive the discharge from a boiler blow-off outlet and to cool the discharge to a temperature which permits safe entry into the drain system.

(28) "Branch" means a part of a piping system other than a riser, main or stack.

(29) "Branch interval" means the vertical distance along a drain stack measured from immediately below a branch drain connection to immediately below the first lower branch drain connection which is 8 feet or more below.

Note: See Appendix for further explanatory material.

(30) "Branch vent" means a vent serving more than one fixture drain.

(31) "B.T.U." means British Thermal Units.

(32) "Building" means a structure for support, shelter or enclosure of persons or property.

(33) "Building, public" means any structure, including exterior parts of such building, such as a porch, exterior platform or steps providing means of ingress or egress, used in whole or in part as a place of resort, assemblage, lodging, trade, traffic, occupancy or use by the public, or by 3 or more tenants.

(34) "Building drain" means horizontal piping within or under a building, installed below the lowest fixture or the lowest floor level from which fixtures can drain by gravity to the building sewer.

(35) "Building drain branch" means a fixture drain which is individually connected to a building drain and is vented by means of a combination drain and vent system.

(35m) "Building subdrain branch" means a fixture drain which is individually connected to a building subdrain and is vented by means of a combination drain and vent system.

(36) "Building drain, sanitary" means a building drain which conveys sewage only.

(37) "Building drain, storm" means a building drain which conveys storm water wastes or clear water wastes, or both.

(38) "Building sewer" means that part of the drain system not within or under a building which conveys its discharge to a public sewer, private interceptor main sewer, private sewage system or other point of disposal.

(39) "Building sewer, sanitary" means a building sewer which conveys sewage only.

(40) "Building sewer, storm" means a building sewer which conveys storm water wastes or clear water wastes, or both.

(41) "Building subdrain" means the horizontal portion of a drain system which does not flow by gravity to the building sewer.

(42) "Burr" means a roughness or metal protruding from the walls of a pipe usually as the result of cutting the pipe.

(44) "Catch basin" means a watertight receptacle built to arrest sediment of surface, subsoil or other waste drainage, and to retain oily or greasy wastes, so as to prevent their entrance into the building drain or building sewer.

(45) "Circuit vent" means a branch vent that serves 2 or more fixture traps which discharge to a horizontal branch drain and connects to the horizontal drain at a point between the 2 most upstream, floor outlet fixtures.

(46) "Cleanout" means an accessible opening in a drain system used for the removal of obstructions.

(47) "Clear water wastes" means liquids other than storm water, having no impurities or where impurities are below a minimum concentration considered harmful by the department, including, but not limited to noncontact cooling water and condensate drainage from refrigeration compressors and air conditioning equipment, drainage of water used for equipment chilling purposes and cooled condensate from steam heating systems or other equipment.

(47m) "Cold water" means water at a temperature less than 85°F.

(48) "Combination fixture" means a fixture combining one sink and laundry tray or a 2 or 3 compartment sink or laundry tray in one unit.

(49) "Combination drain and vent system" means a specially designed system of drain piping embodying the wet venting of one or more fixtures by means of a common drain and vent pipe adequately sized to provide free movement of air in the piping.

(50) "Common vent" means a branch vent connecting at or downstream from the junction of 2 fixture drains and serving as a vent for those fixture drains.

(51) "Conductor" means a drain pipe inside the building which conveys storm water from a roof to a leader, storm drain or storm sewer.

(52) "Control valve" means a device that will stop the flow of water in the water supply system or water-based fire protection system.

(53) "Corporation cock" means a valve:

(a) Installed in a private water main or a water service at or near the connection to public water main; or

(b) Installed in the side of a forced main sewer to which a forced building sewer is connected.

(54) "Critical level" means the reference point on a vacuum breaker which must be submerged before backflow can occur. When the critical level is not indicated on the vacuum breaker, the bottom of the vacuum breaker shall be considered the critical level.

(55) "Cross-connection" means a connection or potential connection between any part of a water supply system and another environment containing substances in a manner that, under any circumstances, would allow the substances to enter the water supply system by means of backsiphonage or back pressure.

(55m) "Cross-connection control device" means any mechanical device which automatically prevents backflow from a contaminated source into a potable water supply system.

(56) "Curb stop" means a valve placed in a water service or a private water main.

(57) "Dead end" means a branch leading from a drain pipe, vent pipe, building drain or building sewer and terminating at a developed length of 2 feet or more by means of a plug, cap or other closed fitting.

(58) "Department" means the department of commerce.

(59) "Developed length" means the length of pipe line measured along the center line of the pipe and fittings.

(60) "Diameter" means in reference to a pipe the nominal inside diameter of the pipe.

Note: Downspout, see "leader".

(60m) "Double check backflow prevention assembly" means a type of cross connection control device which is composed of 2 independently acting check valves internally force loaded to a normally closed position, tightly closing shut-off valves located at each end of the assembly and fitted with test cocks.

(60n) "Double check detector assembly backflow preventer" means a type of a double check backflow prevention assembly which includes a parallel flow meter to indicate leakage or unauthorized use of water downstream of the assembly.

(61) "Drain" means any pipe which carries waste water or water borne wastes.

(62) "Drain system" includes all the piping or any portion of the piping within public or private premises which conveys sewage, storm water or other liquid wastes to a legal point of disposal, but does not include the mains of public sewer systems or a private or public sewage treatment or disposal plant.

(63) "Dwelling unit" means a structure, or that part of a structure, which is used or intended to be used as a home, residence or sleeping place by one person or by 2 or more persons maintaining a common household, to the exclusion of all others.

(64) "Ejector" means an automatically operated device to elevate liquid wastes and sewage by the use of air under higher than atmospheric pressure.

(65) "Faucet" means a valve end of a water pipe by means of which water can be drawn from or held within the pipe.

(66) "Ferrule" means a rigid sleeve used to connect dissimilar plumbing materials.

(67) "Fixture drain" means the drain from fixture to a junction with another drain pipe.

(67m) "Fixture supply" means that portion of a water distribution system serving one plumbing fixture, appliance or piece of equipment.

(68) "Fixture supply connector" means that portion of water supply piping which connects a plumbing fixture, appliance or a piece of equipment to the water distribution system.

(69) "Fixture unit, drainage, dfu" means a measure of the probable discharge into the drain system by various types of plumbing fixtures. The drainage fixture unit value for a particular fixture depends on its volume rate of drainage discharge, on the time duration of a single drainage operation, and on the average time between successive operations.

(70) "Fixture unit, supply, sfu" means a measure of the probable hydraulic demand on the water supply by various types of plumbing fixtures. The supply fixture unit value for a particular fixture depends on its volume rate of supply, on the time duration of a single supply operation, and on the average time between successive operations.

(72) "Flood level rim" means the edge of the receptacle from which water overflows.

(73) "Floor sink" means a receptor for the discharge from indirect or local waste piping installed with its flood level rim even with the surrounding floor.

(75) "Flush valve" means a device located at the bottom of a tank for flushing water closets and similar fixtures.

(76) "Flushometer valve" means a device which discharges a predetermined quantity of water to fixtures for flushing purposes and is controlled by direct water pressure.

(77) "Garage, private" means a building or part of a building used for the storage of vehicles or other purposes, by a family or

less than 3 persons not of the same family and which is not available for public use.

(78) "Garage, public" means a building or part of a building which accommodates or houses self-propelled land, air or water vehicles for 3 or more persons not of the same family.

(79) "Grease interceptor" means a receptacle designed to intercept and retain grease or fatty substances.

(79m) "Hand held shower" means a type of plumbing fixture which includes a cross connection control device, a hose and a hand held discharge piece such as a shower head or spray.

(80) "Health care facility" means any building or part of a building used for purposes such as hospitals, nursing or rest homes, homes for the aged, infirmaries, residential care facilities, sanitariums, mortuaries, medical laboratories, and offices and clinics with operatories for dentists and doctors.

(80m) "High hazard" means a situation where the water supply system could be contaminated with a toxic solution.

(81) "Horizontal pipe" means any pipe or fitting which makes an angle of less than 45° with the horizontal.

(81h) "Hose connection backflow preventer" means a type of cross connection control device which consists of 2 independent checks, force loaded or biased to a closed position, with an atmospheric vent located between the 2 check valves, which is forced loaded or biased to an open position, and a means for attaching a hose.

(81m) "Hose connection vacuum breaker" means a type of cross connection control device which consists of a check valve member force loaded or biased to a closed position and an atmospheric vent valve or means force loaded or biased to an open position when the device is not under pressure.

(82) "Hot water" means water at a temperature of 110° F. or more.

(83) "Hot water storage tank" means a tank used to store water that is heated indirectly by a circulating water heater or by steam or hot water circulating through coils or by other heat exchange methods internal or external to the tank.

(84) "Hydrostatic test" means a test performed on a plumbing system or portion thereof in which the system is filled with a liquid, normally water, and raised to a designated pressure.

(85) "Indirect waste piping" means drain piping which does not connect directly with the drain system, but which discharges into the drain system by means of an air break or air gap into a receptor.

(86) "Individual vent" means a pipe installed to vent a fixture trap.

(87) "Industrial wastes" means the liquid wastes which result from the processes employed in industrial establishments and which are free from fecal matter.

(88) "Interceptor" or "separator" means a device designed and installed so as to separate and retain deleterious, hazardous or undesirable matter from wastes flowing through it.

(89) "Journeyman plumber" means a person as defined in s. 145.01 (7), Stats.

(89m) "Laboratory faucet backflow preventer" means a type of cross connection control device which consists of 2 independently acting check valves force loaded or biased to a closed position and between the check valves a means for automatically venting to atmosphere force loaded or biased to an open position.

(90) "Leader" means a pipe or channel outside a building which conveys storm water from the roof or gutter drains to a storm drain, storm sewer or to grade.

(91) "Load factor" means the percentage of the total connected fixture unit flow rate which is likely to occur at any point in the drain system.

(92) "Local waste piping" means a portion of drain piping which receives the wastes discharged from indirect waste piping

and which discharges those wastes by means of an air break or air gap into a receptor.

(93) "Local vent" means a pipe connecting to a fixture and extending to outside air through which vapor or foul air is removed from the fixture.

(93m) "Low hazard" means a situation where the water supply system could be contaminated with a nontoxic solution.

(94) "Main" means the principal pipe artery to which branches may be connected.

(95) "Manhole" means an opening constructed to permit access to a sewer or any underground portion of a plumbing system.

(96) "Master plumber" means a person as defined in s. 145.01 (8), Stats.

(97) "Mechanical joint" means a connection between pipes, fittings or pipes and fittings by means of a device, coupling, fitting or adapter where compression is applied around the center line of the pieces being joined, but which is neither caulked, threaded, soldered, solvent cemented, brazed nor welded.

(98) "Mobile home" means a vehicle as defined in s. 101.91 (1), Stats.

(99) "Mobile home drain connector" means the pipe which joins the drain piping for a mobile or manufactured home to the building sewer.

(100) "Mobile home park" means any plot or plots of ground as defined in s. 66.058 (1) (e), Stats.

(101) "Multiple dwelling" means a building containing more than 2 dwelling units.

(101m) "Negative pressure" means a pressure less than atmospheric.

(102) "Nonpotable water" means water not safe for drinking, personal or culinary use.

(103) "Nonpublic" means, in the classification of plumbing fixtures, those fixtures in residences, apartments, living units of hotels and motels, and other places where the fixtures are intended for the use by a family or an individual to the exclusion of all others.

(103m) "Nontoxic" means a probable human oral lethal dose of greater than 15 grams of solution per kilogram of body weight.

(104) "Nuisance" means any source of filth or probable cause of sickness pursuant to the provisions of s. 146.14, 1991, Stats.

Note: 1993 Wis. Act 27 repealed concept of "nuisance" and replaced it with "human health hazard". See s. 254.01 (2), Stats.

(105) "Oil interceptor" means a device designed to intercept and retain oil, lubricating grease or other similar materials.

(106) "Offset" means a combination of fittings or bends which brings one section of the pipe out of line but into a line parallel with the other section.

(107) "One or 2-family dwelling" means a building containing not more than 2 dwelling units.

(108) "Open air" means outside the building.

(108m) "Pipe applied atmospheric type vacuum breaker" means a type of cross connection control device where the flow of water into the device causes a float to close an air inlet port and when the flow of water stops the float falls and forms a check valve against backsiphonage and at the same time opens the air inlet port to allow air to enter and satisfy the vacuum.

(109) "Pitch" means the gradient or slope of a line of pipe in reference to a horizontal plane.

(110) "Place of employment" means a place as defined in s. 101.01 (2) (f), Stats.

(111) "Plumbing" means piping, fixtures, appliances, appurtenances, devices and systems as defined in s. 145.01 (10), Stats.

(112) "Plumbing appliance" means any one of a special class of plumbing devices which is intended to perform a special function. The operation or control of the appliance may be dependent

upon one or more energized components, such as motors, controls, heating elements, or pressure or temperature sensing elements. The devices may be manually adjusted or controlled by the user or operator, or may operate automatically through one or more of the following actions: a time cycle, a temperature range, a pressure range, a measured volume or weight.

(113) "Plumbing appurtenance" means a manufactured device or prefabricated assembly of component parts which is an adjunct to the basic piping system and plumbing fixtures. An appurtenance does not demand additional water supply, nor does it add any discharge load to a fixture or the drain system. It is presumed that the appurtenance performs some useful function in the operation, maintenance, servicing, economy, or safety of the plumbing system.

(114) "Plumbing fixture" means a receptacle or device which:

(a) Is either permanently or temporarily connected to the water distribution system of the premises, and demands a supply of water from the system;

(b) Discharges used water, waste materials, or sewage either directly or indirectly to the drain system of the premises; or

(c) Requires both a water supply connection and a discharge to the drain system of the premises.

(115) "Plumbing system" includes the water supply system, the drain system, the vent system, plumbing fixtures, plumbing appliances and plumbing appurtenances which serve a building, structure or premises.

(116) "Potable water" means water which is:

(a) Safe for drinking, personal or culinary use; and

(b) Free from impurities present in amounts sufficient to cause disease or harmful physiological effects and conforming in its bacteriological and chemical quality to the requirements specified in ch. NR 809.

(117) "Pressure relief valve" means a pressure actuated valve held closed by a spring or other means and designed to automatically relieve pressure at a designated pressure.

(117h) "Pressure vacuum breaker assembly" means a type of cross connection control device which consists of an independently operating internally loaded check valve and an independently operating loaded air inlet located on the discharge side of the check valve, a tightly closing shut-off valve located at each end of the assembly, and test cocks.

(117m) "Pressurized flushing device" means a device which uses the water supply to create a pressurized discharge to flush a fixture exclusive of gravity type flushing systems.

(118) "Private interceptor main sewer" means a privately owned sewer serving 2 or more buildings and not directly controlled by a public authority.

(119) "Private water main" means a privately owned water main serving 2 or more buildings and not directly controlled by a public authority.

(121) "Public" means, in the classification of plumbing fixtures, those fixtures which are available for use by the public or employees.

(122) "Public sewer" means a sewer owned and controlled by a public authority.

(123) "Public water main" means a water supply pipe for public use owned and controlled by a public authority.

(124) "Quick closing valve" means a valve or faucet that closes automatically when released manually or controlled by mechanical means for fast action closing.

(125) "Receptor" means a fixture or device which receives the discharge from indirect or local waste piping.

(125m) "Reduced pressure detector backflow preventer" means a type of reduced pressure principle type backflow preventer which includes a parallel flow meter to indicate leakage or unauthorized use of water downstream of the assembly.

(126) "Reduced pressure principle type backflow preventer" means a type of cross connection control device which contains 2 independently acting check valves, separated by an intermediate chamber or zone in which there is a hydraulically operated means for venting to atmosphere, and includes 2 shut-off valves and 4 test cocks.

(127) "Relief vent" means a vent which permits additional circulation of air in or between drain and vent systems.

(128) "Riser" means a water supply pipe which extends vertically one full story or more.

(129) "Roof drain" means a drain installed to receive water collecting on the surface of a roof and to discharge it into a conductor.

(130) "Roughing in" means the installation of all parts of the plumbing system which can be completed prior to the installation of fixtures including drain, water supply and vent piping and the necessary fixture supports.

(131) "Row house" means a place of abode not more than 3 stories in height, arranged to accommodate 3 or more attached row living units in which each living unit is separated from the adjoining unit by a vertical occupancy separation of not less than one-hour fire-resistive construction, extending from the basement or lowest floor to the under side of the roof deck.

(132) "Safing" means a pan or other collector placed beneath a pipe or fixture to prevent leakage from escaping to the floor, ceiling or walls.

(133) "Sand interceptor" means a receptacle designed to intercept and retain sand, grit, earth and other similar solids.

(134) "Sanitary sewer" means a pipe which carries sewage excluding storm water, surface water, ground water and clear water wastes.

(135) "Sewage" means any liquid waste containing animal or vegetable matter in suspension or solution, and may include liquids containing chemicals in solution.

(136) "Sewage grinder pump" means a type of sewage pump which macerates sewage.

(137) "Sewage pump" means an automatic pump for the removal of sewage from a sanitary sump.

(138) "Slip-joint" means a connection in which one pipe slips into another, the joint of which is made tight with a compression type fitting.

(139) "Spigot" means the end of a pipe which fits into a bell or hub.

(139m) "Spill level" means the horizontal plane to which water will rise to overflow through channels or connections which are not directly connected to any drainage system, when water is flowing into a fixture, vessel or receptacle at the maximum rate of flow.

(140) "Spring line, pipe" means the line or place from which the arch of a pipe or conduit rises.

Note: See Appendix for further explanatory material.

(141) "Stack" means a drain or vent pipe which extends vertically one full story or more.

(142) "Stack vent" means a vent extending from the top of a drain stack.

(143) "Standpipe" means a drain pipe serving as a receptor for the discharge wastes from indirect or local waste piping.

(144) "Sterilizer, boiling type" means a device of nonpressure type, used for boiling instruments, utensils, or other equipment for disinfection.

(145) "Sterilizer, instrument" means a device for the sterilization of various instruments.

(146) "Sterilizer, pressure instrument washer" means a pressure vessel designed to both wash and sterilize instruments during the operating cycle of the device.

(147) "Sterilizer, pressure" means a pressure vessel fixture designed to use steam under pressure for sterilizing.

Note: A pressure sterilizer is also referred to as an autoclave.

(148) "Sterilizer, utensil" means a device for the sterilization of utensils.

(149) "Sterilizer vent" means a separate pipe or stack, indirectly connected to the drain system at the lower terminal, which receives the vapors from nonpressure sterilizers, or the exhaust vapors from pressure sterilizers, and conducts the vapors directly to the outer air.

(150) "Sterilizer, water" means a device for sterilizing water and storing sterile water.

(151) "Storm sewer" means a pipe which carries storm water, surface water, ground water and clear water wastes.

(152) "Subsoil drain" means that part of a drain system which conveys the ground or seepage water from the footings of walls or below the basement floor under buildings to the storm sewer or other point of disposal.

(153) "Sump" means a tank or pit which receives sewage or liquid wastes, usually located below the normal grade of the gravity system and which must be emptied by mechanical means.

(154) "Sump pump" means an automatic water pump for the removal of drainage, other than raw sewage, from a sump, pit or low point.

(155) "Sump vent" means a vent pipe from a nonpressurized sump.

(156) "Supports" means hangers, anchors and other devices for supporting and securing pipes, or fixtures to structural members of a building.

(157) "Swimming pool" means a structure, basin, chamber or tank containing an artificial body of water for swimming, diving or recreational bathing having a depth of 2 feet or more at any point.

(158) "Temperature and pressure relief valve" means a combination relief valve designed to function as both a temperature relief and pressure relief valve.

(159) "Temperature relief valve" means a temperature actuated valve designed to automatically discharge at a designated temperature.

(159m) "Tempered water" means water ranging in temperature from 85° F. to less than 110° F.

(159t) "Toxic" means a probable human oral lethal dose of 15 or less grams of solution per kilogram of body weight.

(160) "Trap" means a fitting, device or arrangement of piping so designed and constructed as to provide, when properly vented, a liquid seal which prevents emission of sewer gases without materially affecting the flow of sewage or waste through it.

(161) "Trap seal" means the vertical distance between the top of the trap weir and the top of the dip separating the inlet and outlet of the trap.

(161m) "Trap seal primer, water supply fed" means a type of valve designed to supply water to the trap in order to provide and maintain the water seal of the trap.

(162) "Trap weir" means that part of a trap which forms a dam over which wastes must flow to enter the drain piping.

(163) "Turf sprinkler system" means a system of piping, appurtenances and devices installed underground to distribute water for lawn or other similar irrigation purposes.

(164) "Vacuum" means any pressure less than that exerted by the atmosphere.

(166) "Vacuum relief valve" means a device which admits air into the water distribution system to prevent excessive vacuum in a water storage tank or heater.

(167) "Vent" means a part of the plumbing system used to equalize pressures and ventilate the system.

(168) "Vent header" means a branch vent which connects 2 or more stack vents or vent stacks or both and extends to the outside air.

(169) "Vent stack" means a vertical vent pipe which extends one or more stories.

(170) "Vent system" means a pipe or pipes installed to provide a flow of air to or from a drain system, or to provide a circulation of air within the system to protect trap seals from siphonage and back pressure.

(171) "Vertical pipe" means any pipe or fitting which makes an angle of 45° or less with the vertical.

(171m) "Wall hydrant, freeze resistant automatic draining type vacuum breaker" means a type of device which is designed and constructed with anti-siphon and back pressure preventive capabilities and with means for automatic post shut-off draining to resist freezing.

(172) "Wall mounted water closet" means a water closet attached to a wall in such a way that it does not touch the floor.

(173) "Waste" means the discharge from any fixture, appliance, area or appurtenance.

(174) "Waste sink" means a receptor for the discharge from indirect or local waste piping installed with its flood level rim above the surrounding floor.

(175) "Water closet" means a water flushed plumbing fixture designed to receive human excrement directly from the user of the fixture.

(176) "Water conditioner" means an appliance, appurtenance or device used for the purpose of ion exchange, demineralizing water or other methods of water treatment.

(177) "Water distribution system" means that portion of a water supply system from the building control valve to the connection of a fixture supply connector, plumbing fixture, plumbing appliance, water using equipment or other piping systems to be served.

(178) "Water heater" means any heating device with piping connections to the water supply system which is intended to supply hot water for domestic or commercial purposes other than space heating.

(179) "Water service" means that portion of a water supply system from the water main or private water supply to the building control valve.

(180) "Water supply system" means the piping of a private water main, water service and water distribution system, fixture supply connectors, fittings, valves, and appurtenances through which water is conveyed to points of usage such as plumbing fixtures, plumbing appliances, water using equipment or other piping systems to be served.

(181) "Water treatment device" means a device which:

(a) Renders inactive or removes microbiological, particulate, inorganic, organic or radioactive contaminants from water which passes through the device or the water supply system downstream of the device; or

(b) Injects into the water supply system gaseous, liquid or solid additives other than water, to render inactive microbiological, particulate, inorganic, organic or radioactive contaminants.

(185) "Wet vent" means that portion of a vent pipe which receives the discharge of wastes from other than water closets, urinals or other fixtures which discharge like sewage or fecal matter.

(186) "Yoke vent" means a vent connected to a drain stack for the purpose of preventing pressure changes in the drain stack.

History: Cr. Register, February, 1985, No. 350, eff. 3-1-85; r. (43), (71), (74), (120), (177) to (184), r. and recr. (53), (68) and (115), am. (56) and (163), cr. (55m), (67m), (159m), (177) to (181), Register, May, 1988, No. 389, eff. 6-1-88; cr. (35m), am. (111), Register, August, 1991, No. 428, eff. 9-1-91; am. (14), r. (7), (8), (15) and (52), r. and recr. (5), (16) to (18), (55), (55m), (126) and (165), cr. (47m), (60m), (60n), (79m), (80m), (81m), (89m), (93m), (101m), (103m), (117m), (125m), (139m), (159), (161m), (165m) and (171m), Register, February, 1994, No. 458, eff. 3-1-94; correction in (89), (96), (98) and (110) made under s. 13.93 (2m) (b) 7., Stats., Register, February, 1994, No. 458; correction in (58) made under s. 13.93 (2m) (b) 6., Stats.,

Register, October, 1996, No. 490; am. (89m), (125m), (161m), (171m), renum. (165) to be (117h) and am., (165m) to be (108m) and am., cr. (18m), (52), (81h), Register, February, 1997, No. 494, eff. 3-1-97.

**Subchapter II—
Administration & Enforcement**

Comm 82.20 Plan review and approval. (1) GENERAL. Plans and specifications shall be submitted to the department or to an approved agent municipality for review in accordance with pars. (a) and (b).

Note: A plan approval application form (SBD-6154) is available from the Safety and Buildings Division, P. O. Box 7969, Madison, WI 53707.

(a) *Department review.* Plans and specifications for the types of installations listed in Table 82.20-1 shall be submitted to the department for review, regardless of where the installation is to be located. Written approval for the plans shall be obtained prior to installation of the work.

(b) *Department or agent municipality review.* Plumbing plans and specifications for the types of plumbing installations listed in Table 82.20-2 shall be submitted for review to an agent municipality, if the installation is to be located within the agent municipality or to the department, if the installation is not to be located within an agent municipality. A municipality shall be designated as an agent municipality in accordance with sub. (2). Written approval for the plumbing plans shall be obtained prior to installation of the plumbing.

1. Plan review and approval of one- and 2-family dwellings. Review and approval of plumbing plans for one- and 2-family dwellings shall be in accordance with the provisions specified in s. ILHR 20.09.

2. 'Local review'. An agent municipality may require by local ordinance the submittal and review of plumbing plans for those installations involving 10 or less plumbing fixtures.

2. Grease interceptors to be installed for public buildings.
3. Garage catch basins and oil interceptors to be installed for public buildings.
4. Automatic car wash facilities.
5. Sanitary dump stations.
6. Private water mains.
7. Water supply systems and drain systems to be installed for mobile home parks and campgrounds.^c
8. Private interceptor main sewers.
9. Chemical waste systems regardless of the number of plumbing fixtures involved.^c

^aA water heater is to be counted as a plumbing fixture.

^bFor the purpose of plan submittal, public buildings do not include zero-lot-line row houses where each living unit is served by an individual water service and an individual building sewer.

^cOnly agent municipalities which are cities of the first class may review these types of installations.

(2) **AGENT MUNICIPALITIES.** The department may designate to an approved municipality the authority to review and approve plumbing plans and specifications for those plumbing installations to be located within the municipality's boundary limits and which require approval under sub. (1) (b).

(a) An agent municipality shall employ at least 2 full time plumbing inspectors who have been qualified by the department.

1. The primary duties of the plumbing inspectors shall include plumbing plan review.

2. The plumbing inspectors shall be Wisconsin licensed master or journeyman plumbers.

Note: See Appendix for listing of agent municipalities.

(b) An agent municipality may waive its jurisdiction for plan review and approval for any project, in which case plans shall be submitted to the department for review and approval.

(c) Agent municipalities may set by ordinance the fees for plan review services.

(3) **PRIORITY PLAN REVIEW.** An appointment may be made with the department to facilitate the examination of plans in less than the normal processing time. Complete plans along with the fee specified in s. Comm 2.61 (3), shall be submitted to the department. The plans shall comply with all of the provisions of this section.

(4) **PLANS AND SPECIFICATIONS.** (a) At least 2 sets of plans and one copy of specifications which are clear, legible and permanent copies shall be submitted for examination and approval.

(b) If a submitter wants more than 2 sets of approved plans returned, the fees specified in s. Comm 2.64 shall accompany the plan submittal.

(c) All plans submitted for approval shall be accompanied by sufficient data and information for the department to judge if the installation and its performance will meet the requirements of this chapter and ch. Comm 84.

1. Information to accompany the plans shall include the location or address of the installation and the name of the owner.

2. Plans proposing the installation, creation or extension of a private interceptor main sewer which is to discharge to a municipal treatment facility shall:

a. Be accompanied by a letter from the appropriate designated planning or management agency indicating conformance with an approved areawide water quality management plan under ch. NR 121; and

b. Not be approved, if the municipality is ineligible for sanitary sewer extension approvals under s. NR 110.05.

3. Except as provided in subd. 4., plans proposing the installation of a building sewer for new construction which is to discharge to a municipal treatment facility shall:

Table 82.20-1

SUBMITTALS TO DEPARTMENT

Type of Installation
1. All plumbing, new installations, additions and alterations, regardless of the number of plumbing fixtures involved, to be installed in health care facilities.
2. Plumbing, new installations, additions and alterations involving 11 or more plumbing fixtures, to be installed in buildings owned by a metropolitan or sanitary sewer district. ^a
3. Plumbing, new installations, additions and alterations involving 11 or more plumbing fixtures, to be installed in buildings owned by the state. ^a
4. Engineered plumbing systems.
5. Controlled roof drainage systems.
6. Reduced pressure principle backflow preventers and reduced pressure detector backflow preventers.
7. Pressure vacuum breaker assembly.
8. Back siphonage backflow vacuum breaker.

^aA water heater is to be counted as a plumbing fixture.

Table 82.20-2

SUBMITTALS TO DEPARTMENT OR AGENT MUNICIPALITY

Type of Plumbing Installation
1. New installations, additions and alterations to drain systems, vent systems, water service systems, and water distribution systems involving 11 or more plumbing fixtures to be installed in public buildings. ^{a,b}

a. Be accompanied by a letter from either the appropriate designated management agency or sanitary district indicating conformance with an approved areawide water quality management plan; and

b. Not be approved, if the municipality is ineligible for sanitary sewer extension approvals under s. NR 110.05.

4. Plans proposing the installation of a building sewer for new construction which is to discharge to a municipal treatment facility shall not be required to comply with subd. 3., if:

a. The proposed installation is served by an existing building sewer which extends from the lot line to the public sewer and the proposed installation does not exceed the capacity of the existing building sewer or sewers; or

b. The plans indicate that a drainage load of not more than 54 drainage fixture units will be discharged through the building sewer.

Note: See Appendix for listing of water quality management agencies.

(d) 1. a. Except as provided in subd. 1. b., plumbing plans and specifications shall be sealed or stamped and shall be signed by a Wisconsin registered architect, engineer or plumbing designer in accordance with ch. A-E 2.

b. A master plumber may design and submit for approval plumbing plans and specifications for a plumbing system which the master plumber is to install. Each sheet of plans and specifications the master plumber submits shall be signed and dated and shall include the Wisconsin license number of the master plumber. Where more than one sheet is bound together into one volume, only the title sheet or index sheet need to be signed and dated by the master plumber responsible for their preparation, if the signed sheet clearly identifies all of the other sheets in the volume.

2. Automatic fire sprinkler plans and specifications for cross connection control shall be:

a. Signed and sealed in accordance with s. A-E 2.02 by an architect, engineer or sprinkler designer who is registered by the department of regulation and licensing; or

b. Signed, including license number, and dated by an automatic fire sprinkler contractor who is responsible for the installation of the sprinklers and who is licensed by the department.

(5) PLAN REVIEW. Except as provided in sub. (12), the department shall review and make a determination on an application for plan review within 15 days of receiving the required information and fees.

(a) *Conditional approval.* If, upon review, the department determines that the plans substantially conform to the provisions of chs. Comm 82 to 84, a conditional approval, in writing, shall be granted. All noncode complying conditions stated in the conditional approval shall be corrected before or during installation.

(b) *Denial of approval.* If, upon review, the department determines that the plans do not substantially conform to the provisions of chs. Comm 82 to 84, the request of conditional approval shall be denied in writing.

(6) EVIDENCE OF APPROVAL. The plumber responsible for the installation of the plumbing shall keep at the construction site at least one set of plans bearing the department's or the agent municipality's stamp of approval and at least one copy of specifications. The plans and specifications shall be open to inspection by an authorized representative of the department.

(7) FEES. Fees for plumbing plan review and petition for variance shall be submitted in accordance with ss. Comm 2.64 and 2.52.

(8) REVISIONS. All changes or modifications, which involve the provisions of chs. Comm 82 to 84, made to plumbing plans and specifications, which have been granted approval under sub. (1), shall be submitted to the department or agent municipality for examination. All changes and modifications shall be approved in writing by the department or agent municipality prior to installation of the plumbing.

(9) REVOCATION OF APPROVAL. The department may revoke any approval, issued under the provisions of this chapter, for any false statements or misrepresentation of facts on which the approval was based.

(10) DEPARTMENT LIMITATION AND EXPIRATION OF APPROVAL. (a) A conditional approval of a plan by the department shall not be construed as an assumption by the department of any responsibility for the design; and the department does not hold itself liable for any defects in construction, nor for any damages that may result from the specific installation.

(b) Plan approval by the department or its authorized representative shall expire 2 years after the date indicated on the approval letter, if construction has not commenced within that 2 year period.

(11) PETITION FOR VARIANCE. (a) *Procedure.* The department will consider and may grant a variance to an administrative rule upon receipt of a fee and a completed petition for variance form from the owner, provided an equivalency is established in the petition for variance which meets the intent of the rule being petitioned. The department may impose specific conditions in granting a variance to promote the protection of the health, safety or welfare of the public. Violation of those conditions under which the variance is granted constitutes a violation of this chapter.

(b) *Petition processing time.* Except for priority petitions, the department shall review and make a determination on a petition for variance within 30 business days of receipt of all calculations, documents and fees required to complete the review. The department shall process priority petitions within 10 business days.

Note: The petition for variance form (SBD-8) is available from the Safety and Buildings Division, P. O. Box 7969, Madison, WI 53707.

(12) ENGINEERED PLUMBING SYSTEMS. The provisions of this chapter or ch. Comm 84 are not intended to prevent design and use of engineered plumbing systems if the system has been first approved by the department. The department may approve an engineered plumbing system, if the system complies with the intent of chs. Comm 82 to 84.

(a) *Plans and specifications.* Plans and specifications for all engineered plumbing systems shall be submitted and reviewed in accordance with subs. (4) to (10).

1. The plans, specifications and all pertinent data shall indicate the nature and extent of the proposed system before an approval is granted.

2. Plans, specifications and data for an engineered plumbing system shall show the complete drain system, vent system, and water supply system including:

- a. The plumbing fixture and appliance arrangements;
- b. The pipe sizes;
- c. The direction of flow for drain pipes;
- d. The grade of horizontal drain pipes;
- e. The drainage fixture unit values for all drain pipes; and
- f. The water supply fixture unit values for all water supply pipes.

3. When requested, additional details and data pertaining to the design, installations and materials of an engineered plumbing system shall be submitted to the department.

4. The department shall review and make a determination on an application for plan review of an engineered plumbing system within 3 months of receiving the required information and fees.

(b) *Inspections.* The registered architect, engineer, plumbing designer or master plumber responsible for the design of the engineered plumbing system shall provide on-site supervision of the installation.

1. Upon completion of the installation, the registered architect, engineer, plumbing designer or master plumber shall certify in writing to the department that the installation is in compliance with the approved plans, specifications and data.

2. The department may require periodic inspections of the system by the registered architect, engineer, plumbing designer or master plumber after the installation is completed to monitor the performance of the system.

(13) PENALTIES. Penalties for violations of this chapter shall be assessed in accordance with ss. 145.12 and 145.25 (4), Stats.

History: Cr. Register, February, 1985, No. 350, eff. 3-1-85; am. (1) (intro.), r. and recr. Tables 82.20-1 and 82.20-2, r. (5), renum. (6) to (12) to be (5) to (11), cr. (5) (intro.) and (12), Register, May, 1988, No. 389, eff. 6-1-88; correction in (1) (b) 1. made under s. 13.93 (2m) (b) 7., Stats., Register, May, 1988, No. 389; am. (4) (c) 2. intro. and 4. a. and b., Register, February, 1991, No. 422, eff. 3-1-91; am. (4) (c) 3.a., Register, August, 1991, No. 428, eff. 9-1-91; am. (1) (intro.), (a), (4) (a) to (c) 1., (5) (a), (b) and Tables 82.20-1 and 82.20-2, renum. (4) (d) and (e) to be (4) (d) 1. a. and b. and am. (4) (d) 1. a., cr. (4) (d) 2., Register, February, 1994, No. 458, eff. 3-1-94; correction in (7) made under s. 13.93 (2m) (b) 7., Stats., Register, February, 1994, No. 458; corrections made under s. 13.93 (2m) (b) 7., Stats., Register, October, 1996, No. 490; am. Tables 82.20-1, 2, (1) (b) 2., Register, February, 1997, No. 494, eff. 3-1-97.

Comm 82.21 Testing and maintenance. (1) TESTING OF PLUMBING SYSTEMS. Except as provided in par. (a), all new plumbing and all parts of existing systems which have been altered, extended or repaired shall be tested as specified in par. (d) to disclose leaks and defects before the plumbing is put into operation.

(a) *Waiver of testing.* 1. The testing of the plumbing shall not be required where the installation does not include the addition, replacement, alteration or relocation of any water distribution, drain or vent piping.

2. a. Field testing the installation of a storm building sewer and a storm private interceptor main sewer is not required.

b. The joints and connections to be employed for storm building sewer piping shall conform with s. Comm 84.40 (1) (a).

(b) *Local inspection.* Where the plumbing is installed in a municipality having a local inspector, the testing of the plumbing shall be done in the presence of a plumbing inspector, except as provided in subd. 1. b.

1. Notice of inspection. a. The plumber responsible for the installation shall notify the plumbing inspector in person, by telephone or in writing when the work is ready for inspection.

b. If the inspection is not made by the end of the normal business day following the day of notification, not including Saturday, Sunday or legal holidays, the plumber may proceed with the testing and the installation.

2. Preparations for inspection. When the installation is ready for inspection, the plumber shall make such arrangements as will enable the plumbing inspector to inspect all parts of the plumbing system. The plumber shall have present the proper apparatus and appliances for making the tests, and shall furnish such assistance as may be necessary in making the inspection.

3. Rough-in inspection. A rough-in inspection shall be made when the plumbing system is roughed-in and before fixtures are set. Except as provided in subd. 1., plumbing work shall not be closed in, concealed, or covered until it has been inspected and approved by the plumbing inspector and permission is granted to do so.

4. Final inspection. a. Upon completion of the plumbing installation and before final approval is given, the plumbing inspector shall inspect the work.

b. When required by a municipality, the plumbing installation shall be subject to a final test conducted in accordance with par. (d) 7. The final test shall be observed by the plumbing inspector.

5. Reinspections. Whenever the plumbing official finds that the work or installation does not pass any initial test or inspection, the necessary corrections shall be made to comply with this chapter. The work or installation shall then be resubmitted for inspection to the plumbing inspector.

(c) *Inspection of one- and 2-family dwellings.* The inspection of plumbing installations for one- and 2-family dwellings shall be in accordance with ss. ILHR 20.08 to 20.11.

(d) *Testing provisions.* 1. General. The testing of plumbing installations shall be conducted in accordance with this paragraph.

a. Equipment, material and labor for tests. All equipment, material and labor required for testing a plumbing system or part thereof shall be furnished by the plumber responsible for the installation.

b. Exposure of work. Except as provided in subds. 2. and 5., all new, altered, extended or replaced plumbing shall be left uncovered and unconcealed until it has been tested. Where the work has been covered or concealed before it is tested, it shall be exposed for testing.

2. Sanitary building sewer and sanitary private interceptor main sewer. A sanitary building sewer and a sanitary private interceptor main sewer shall be tested for leaks and defects with water or air before or after being covered in accordance with either subd. 2. a. or b. The test for leaks and defects may be applied to the entire building sewer or private interceptor main sewer or in sections. For the purposes of this subdivision, the testing of a building sewer or private interceptor main sewer is not required to include the manholes serving the sewer.

a. The building sewer or private interceptor main sewer shall be tested by insertion of a test plug at the point of connection with the public sewer. The sewer shall then be filled with water under a head of not less than 10 feet. The water level at the top of the test head of water shall not drop for at least 15 minutes.

b. The air test shall be made by attaching an air compressor testing apparatus to any suitable opening, and, after closing all other inlets and outlets to the system, forcing air into the system until there is a uniform gauge pressure of 3 pounds per square inch. This pressure shall be held without introduction of additional air for a period of at least 15 minutes.

3. Building drain. The entire building drain with all its branches, receptacles and connections shall be brought so far as practical to the surface or grade of the basement floor and shall be tested with water or air in accordance with subd. 7.

4. Drain and vent systems. The piping of a drain and vent systems, including conductors, shall be tested upon completion of the rough piping installation with water or air in accordance with subd. 7.

5. Private water mains and water services. Private water mains and water services shall be inspected before being covered. The private water mains and water services shall be tested and proven water tight under water pressure not less than the working pressure under which it is to be used. The water used for testing shall be obtained from a potable source of supply.

6. Water distribution system. The piping of a water distribution system shall be tested and proved water tight under a water pressure not less than the working pressure under which it is to be used. The water used for tests shall be obtained from a potable source of supply.

7. Test methods for drain and vent systems. A test for watertightness shall be applied to the entire drain and vent system at one time or to the entire system in sections after the rough piping has been installed in accordance with either subd. 7. a. or b.

a. If applied to the entire system, all openings in the piping shall be tightly closed, except the highest opening, and the system shall be filled with water to the point of overflow. If the system is tested in sections, each opening shall be tightly plugged except the highest opening of the section under test, and each section shall be filled with water, but a section shall not be tested with less than a 10 foot head of water. In testing successive sections, at least the upper 10 feet of the next preceding section shall be tested, so that no joint or pipe in the building, except the uppermost 10 feet of the system, is subjected to a test of less than a 10 foot head of water. The water shall be kept in the system or in the portion under test for at least 15 minutes before inspection starts. The system shall then be tight at all points.

b. The air test shall be made by attaching an air compressor testing apparatus to any suitable opening, and, after closing all other inlets and outlets to the system, forcing air into the system until there is a uniform gauge pressure of 5 pounds per square inch or sufficient to balance a column of mercury 10 inches in height. This pressure shall be held without introduction of additional air for a period of at least 15 minutes.

8. Final test. Where required by the local plumbing inspector, after the plumbing fixtures have been installed and the traps filled with water, the connections shall be tested and proved gas and watertight by either one of the methods specified in subd. 8. a. or b.

a. The smoke test shall be made by introducing a pungent, thick smoke, produced by one or more smoke machines, into the completed system. When the smoke appears at stack openings on the roof, the openings shall be closed and a pressure equivalent to a one inch water column shall be built and maintained for the period of the inspection.

b. The air test shall be made by attaching an air compressor testing apparatus to any suitable opening, and, after closing all other inlets and outlets to the completed system, forcing air into the system until a pressure equivalent to the gauge pressure of a one inch water column. This shall be accomplished by the use of The pressure shall remain constant for the period of inspection without the introduction of additional air.

(2) MAINTENANCE AND REPAIRS. All plumbing systems, both existing and new, and all parts thereof, shall be maintained in a safe and sanitary condition. All devices or safeguards which are required by this chapter shall be maintained in good working order. The owner shall be responsible for the maintenance of plumbing systems.

(a) *Existing systems.* Whenever it appears upon inspection that any part of an existing plumbing system is defective, or fails to conform to the requirements of this chapter and if failure tends to create a health hazard, it shall be repaired, renovated, replaced or removed.

(b) *Fixtures replaced.* When an old or defective fixture is removed, to be replaced by a new fixture, and no other fixture or piping is to be added or remodeled, it is not necessary to reconstruct the drain or vent piping to make it conform to the provisions of this chapter, unless the drain or vent piping is in a defective condition. Where the existing drain or vent piping does not conform to the provisions of this chapter, the department may require the new fixtures to be provided with deep seal traps.

(c) *Reconstruction.* When old or defective plumbing is to be remodeled, additional fixtures installed, or the whole plumbing system moved to another part of the building, the remodeled system shall be made to conform to this chapter.

(d) *Materials reused.* All plumbing fixtures, drain and vent pipes removed from a building, if found to be in good condition, may be reused, if the fixtures and pipes are approved by the department or local plumbing inspector and the owner of the building in which they are to be installed gives written consent.

(e) *Existing building sewers and drains.* Existing building sewers and drains may be used in connection with new buildings only when they are found on examination and test to conform to the requirements of this chapter governing building sewers and drains. If the existing work is found defective, the local or state inspector shall notify the owner of the changes necessary to make it conform to the requirements of this chapter.

(f) *Repairs.* All repairs to fixtures or piping shall be done in conformance with the provisions of this chapter, except repair clamps or bands may be used for emergency situations.

(g) *Demolition of structures.* When a structure is demolished or removed, all sanitary sewer, storm sewer and water supply connections shall be sealed and plugged in a safe manner.

(h) *Dead ends.* If a dead end is created in the removal of any part of a drain system, all openings in the drain system shall be properly sealed.

(3) MAINTENANCE AND TESTING OF CROSS CONNECTION CONTROL DEVICES. (a) All cross connection control devices shall be maintained in accordance with the appropriate standard.

(b) 1. A performance test shall be conducted for a reduced pressure principle backflow preventer, a reduced pressure detector backflow preventer, a double check backflow prevention assembly, a double check detector assembly backflow preventer, a pressure vacuum breaker assembly and a back siphonage backflow vacuum breaker:

a. At the time of installation;

b. Immediately after repairs or alterations to the device have occurred; and

c. At least annually.

2. a. The performance test for a reduced pressure principle backflow preventer shall be conducted in accordance with ASSE 5010-1013-1.

b. The performance test for a reduced pressure detector backflow preventer shall be conducted in accordance with ASSE 5010-1047-1.

c. The performance test for a double check backflow prevention assembly shall be conducted in accordance with ASSE 5010-1015-1, 5010-1015-2, 5010-1015-3 or 5010-1015-4.

d. The performance test for a double check detector assembly backflow preventer shall be conducted in accordance with ASSE 5010-1048-1, 5010-1048-2, 5010-1048-3 or 5010-1048-4.

e. The performance test for a pressure vacuum breaker assembly shall be conducted in accordance with ASSE 5010-1020-1.

3. A performance test for a reduced pressure principle backflow preventer, a reduced pressure detector backflow preventer, a double check backflow prevention assembly, a double check detector assembly backflow preventer, a pressure vacuum breaker assembly and a back siphonage backflow vacuum breaker shall be conducted by an individual registered by the department in accordance with s. Comm 5.99.

4. a. The results of a performance test for a reduced pressure principle backflow preventer, a reduced pressure detector backflow preventer, pressure vacuum breaker assembly, and back siphonage backflow vacuum breaker, shall be forwarded to the department within 60 days of completion of the test.

b. The results of performance tests for a reduced pressure principle backflow preventer, a reduced pressure detector backflow preventer, pressure vacuum breaker assembly, and back siphonage backflow vacuum breaker, shall be recorded in a format prescribed by the department.

Note: The form for reporting the test results (SBD-9927) is available from, and the test results are to be sent to, the Safety and Buildings Division, P. O. Box 7969, Madison, WI 53707.

5. The results of performance tests for a double check backflow prevention assembly, and a double check detector assembly backflow preventer shall be maintained at the site where the device is installed and shall be made available upon request to the department or government entity exercising jurisdiction.

(c) The maintenance and performance testing requirements of this subsection shall also apply to those cross connection control devices installed prior to the effective date of this subsection.

History: Cr. Register, February, 1985, No. 350, eff. 3-1-85; r. and rec. (1) (d) 5., am. (1) (d) 7. intro., Register, May, 1988, No. 389, eff. 6-1-88; correction in (1) (c) made under s. 13.93 (2m) (b) 7., Stats., Register, May, 1988, No. 389; renun. (1) (a) and (2) (b) to (j) to be (1) (a) 1. and (2) (a) to (h), r. (2) (a), cr. (1) (a) 2. and (3), r. and rec. (1) (d) 1. (intro.), am. (1) (d) 2. (intro.), Register, February, 1994, No. 458, eff. 3-1-94; am. (3) (b) 3., Register, October, 1996, No. 490, eff. 11-1-96; am. (3), Register, February, 1997, No. 494, eff. 3-1-97.

**Subchapter III—
Drain and Vent Systems**

Comm 82.30 Sanitary drain systems. (1) SCOPE. The provisions of this section set forth the requirements for the design and installation of sanitary drain systems, including building drains and building sewers.

Note: The provisions for storm and clear water drain systems are specified in s. Comm 82.36.

(2) MATERIALS. All sanitary drain systems shall be constructed of approved materials in accordance with ch. Comm 84.

(3) LOAD ON DRAIN PIPING. (a) Intermittent flow fixtures. The load factor on drain piping shall be computed in terms of drainage fixture unit values specified in Table 82.30-1 for the corresponding fixture listed. Drainage fixture unit values for intermittent flow fixtures not listed in Table 82.30-1 shall be computed on the basis of one fixture unit equalling 7.5 gallons per minute of flow.

(b) Continuous flow devices. Drainage fixture unit values for continuous or semicontinuous flow devices such as pumps, ejectors, air conditioning equipment or similar devices shall be computed on the basis of one fixture unit for each 2 gallons per minute of flow rate of discharge into the drain system.

**TABLE 82.30-1
DRAINAGE FIXTURE UNIT VALUES**

Type of Fixture	Drainage Fixture Unit Value (dfu)	Trap Size Min. Diam. (in inches)
Automatic clothes washers,		
Commercial, individual	4	2
Commercial, large capacity	a	a
Self Service Laundry	3	1½
Residential	3	1½
Bathroom Group, includes: water closet, lavatory, bathtub or shower	6	
Bathtubs, all types ^b	2	1½
Bedpan Washer	6	2
Beer Tap	½	1¼
Bidet	2	1½
Bottle Cooler	½	1¼
Coffee Maker	½	1¼
Cuspidor, fountain or dental	1	1¼
Dipper Well	1	1¼
Dishwasher, commercial type	c	c
Dishwasher, residential type	2	1½
Drinking Fountain	½	1¼
Exhaust Hood Washer	4	2
Floor Drain,		
2 inch	2	2
3 inch	3	3
4 inch	4	4
Larger than 4 inch	4	d
Glass Filler	½	1¼
Glass Washer	2	1½
Ice Chest	½	1½
Laundry Tray, 1 or 2 compartment	2	1½
Lavatory	1	1¼
Refrigerated Food Display Case	1	1
Shower Stall		
Residential	2	2
Public, individual	2	2
Public, group	2 per shower head	2
Sinks,		
Cup	½	1¼
Factory, wash, per set of faucets	1	1½
Fountain wash up, per station	1	1½
Fountain or Bar, 4 compartments or less	3	1½

**Table 82.30-1 (continued)
DRAINAGE FIXTURE UNIT VALUES**

Type of Fixture	Drainage Fixture Unit Value (dfu)	Trap Size Min. Diam. (in inches)
Food Waste Grinder, commercial 2 HP or less	2	f
Food Waste Grinder, commercial 3 HP or more	3	f
Laboratory	2	1½
Laboratory, school	2	1½
Classroom	1	1¼
Pack or plaster	3	2
Residential, with or without food waste grinder	2	1½
Restaurant,		
Scullery, pots and pans—4 compartments or less	3	f
Food, rinsing, cleaning or thawing	3	2
Service Sink, Flushing Rim	6	3
Service Sink, 2 inch diameter, wall outlet	2	2
Service Sink, 3 inch diameter, wall outlet	3	3
Service Sink, 2 inch diameter, floor outlet	2	2
Service Sink, 3 inch diameter, floor outlet	3	3
Shampoo Sink, barber or beauty parlor	2	1½
Surgeons, wash up	3	1½
Wash Fountain, circular and semi-circular	2	1½
Receptors of Indirect Wastes, gravity flow discharge		
1½ inch receptor outlet diameter	2	1½
2 inch receptor outlet diameter	3	2
3 inch receptor outlet diameter	4	3
4 inch receptor outlet diameter	6	4
larger than 4 inch receptor outlet diameter	8	f
Soda Dispenser	½	1¼
Sterilizers,		
Bedpan	4	2
Garbage can washer	3	3
Instrument or water	1	1½
Urinal	2	g
Water Closet, nonpublic	4	g
Water Closet, public	6	g

a Based on discharge rate of the fixture.
 b Includes foot, sitz and infant baths and regular bathtubs with or without showers or whirlpool circulation piping.
 c Based on discharge rates and number of outlets; a 4-inch diameter trap and drain pipe minimum recommended.
 d Trap size corresponds to the size of the floor drain.
 f Trap size corresponds to the size of the drain outlet.
 g Trap size specified in referenced standards of s. Comm 84.20.

(4) SIZE OF DRAIN PIPING. (a) *Maximum loading.* 1. The total drainage load in any portion of drain piping shall not exceed the limits specified in Tables 82.30-2 and 82.30-3.

2. The drainage fixture unit values assigned to a receptor which is to receive only the indirect waste discharge from a relief valve on a domestic water heater may be disregarded when determining the minimum size of the building drain and building sewer. Any drain piping between the receptor and the building drain shall be sized by including the assigned fixture unit values for the type

of receptor.

Note: See s. Comm 82.31 (17) for sizing requirements of combination drain and vent systems.

Note: See Appendix for further explanatory material.

(b) *Minimum size of underground drain piping.* Any pipe of the drain system installed underground, other than the building sewer, shall not be less than 2 inches in diameter. Any portion of underground drain piping which is 2 inches in diameter shall not exceed a length of 20 feet.

Table 82.30-2
HORIZONTAL AND VERTICAL DRAIN PIPING

Pipe Diameter (in inches)	Maximum Number of Drainage Fixture Units Which May Drain Through Any Portion of Horizontal and Vertical Drain Piping			
	Horizontal Drain Piping ^a	Vertical Drain Piping of 3 Branch Intervals or Less ^b	Vertical Piping in Drain Stacks of more than 3 Branch Intervals ^b	
			Total Discharge from Side Connections into One Branch Interval	Total Discharge through Any Portion
1 ¹ / ₄	1	2	1	2
1 ¹ / ₂	3	4	2	8
2	6	10	6	24
3	20 ^c	48 ^d	20 ^c	72 ^d
4	160	240	90	500
5	360	540	200	1,100
6	620	960	350	1,900
8	1,400	2,200	600	3,600
10	2,500	3,800	1,000	5,600
12	3,900	6,000	1,500	8,400

a: Does not include building drains and building sewers.

b: Drain stacks may be reduced in size as the drainage load decreases to a minimum diameter of one half of the diameter required at the base of the stack, but not smaller than that required for a stack vent under s. Comm 82.31 (14) (a).

c: Not more than 2 water closets or similar flush action type fixtures of 4 or more drainage fixture units.

d: Not more than 2 water closets or similar flush action type fixtures of 4 or more drainage fixture units within each branch interval nor more than 6 flush action type fixtures on the stack.

Table 82.30-3
BUILDING DRAINS, BUILDING SUBDRAINS, BUILDING SEWERS AND PRIVATE INTERCEPTOR MAIN SEWERS^a

Pipe Diameter (in inches)	Maximum Number of Drainage Fixture Units Which May Drain Through Any Portion of a Building Drain, Building Subdrain, Building Sewer or Private Interceptor Main Sewer			
	Pitch (inch per foot)			
	1/16	1/8	1/4	1/2
2	NP ^b	NP	6	9
3	NP	36 ^c	42 ^c	50 ^c
4	NP	180	216	250
5	NP	390	480	575
6	NP	700	840	1,000
8	1,400	1,600	1,920	2,300
10	2,500	2,900	3,500	4,200
12	3,900	4,600	5,600	6,700
15	7,000	8,300	10,000	12,000

a: Private interceptor main sewers 6 inches or less in diameter, see s. NR 110.13 for private interceptor main sewers 8 inches or larger in diameter.

b: NP means Not Permitted.

c: Not more than 2 water closets or similar flush action type fixtures of 4 or more drainage fixture units.

(c) *Minimum size of building sewers.* 1. Gravity flow sewers. The minimum size of a gravity flow sanitary building sewer shall be 4 inches in diameter. A municipality or sanitary district by ordi-

nance may require that portion of the building sewer between the lot line and the public sewer to be larger than 4 inches in diameter.

2. Pressurized sewers. a. Sewers pressurized through the use of sewage ejectors, sewage pumps or sewage grinder pumps shall be sized to maintain a minimum flow velocity of 2 feet per second and shall be in accordance with the ejector or pump manufacturer's recommendations.

b. Pressurized building sewers shall be sized not less than 2 inches in diameter for sewage ejectors and sewage pumps, and 1 1/4 inches in diameter for all sewage grinder pumps.

(d) *Minimum size of private interceptor main sewers.* 1. Except as provided in subd. 3., the minimum size of a gravity flow private interceptor main sewer shall be 4 inches in diameter.

2. Except as provided in subd. 3., the minimum size of pressurized private interceptor main sewer shall be such so as to maintain a minimum flow velocity of 2 feet per second.

3. A municipality or a sanitary district may by ordinance, require the minimum size of a private interceptor main sewer to be larger than 4 inches in diameter.

4. Private interceptor main sewers 6 inches or less in diameter may not exceed the drainage fixture limits in Table 82.30-3.

5. Private interceptor main sewers 8 inches or larger in diameter shall conform with the design flow criteria specified in ch. NR 110.

(e) *Future fixtures.* Where provisions are made for the future installation of fixtures, the drainage fixture unit values of such fixtures shall be considered in determining the required sizes of drain and vent pipes. Construction to provide for future installations shall be terminated with a plugged fitting or fittings.

(5) *PITCH OF HORIZONTAL DRAIN PIPING.* All horizontal drain piping 4 inches or larger in diameter shall be installed at a pitch which produces a computed velocity of at least 2 feet per second when flowing half full.

(a) *Horizontal branch drains.* 1. The minimum pitch of horizontal branch drains 2 inches or less in diameter shall be 1/4 inch per foot:

2. The minimum pitch of horizontal branch drains larger than 2 inches in diameter shall be 1/8 inch per foot.

(b) *Building drains and building sewers.* 1. The minimum pitch of building drains shall be in accordance with Table 82.30-3.

2. a. The minimum pitch of building sewers 10 inches or less in diameter shall be in accordance with Table 82.30-3.

b. The minimum pitch of building sewers 12 inches or larger in diameter shall conform with the minimum pitches specified for municipal sewers in s. NR 110.13 (2) (c).

(c) *Private interceptor main sewers.* 1. The minimum pitch of private interceptor main sewers 6 inches or less in diameter shall be in accordance with Table 82.30-3.

2. The minimum pitch of private interceptor main sewers 8 inches or larger in diameter shall conform with the minimum pitches specified for municipal sewers in s. NR 110.13 (2) (c).

(6) *OFFSETS IN VERTICAL DRAINS.* Offsets in vertical drain piping shall be in accordance with this subsection.

(a) *Offsets of 45° or less.* 1. An offset in a vertical drain, with a change in direction of 45° or less from the vertical, shall be sized as a vertical drain piping in accordance with sub. (4).

2. Where a horizontal branch connects to a stack within 2 feet above or below an offset with a change of direction of 30 to 45° from the vertical and the offset is located below 2 or more branch intervals, a relief vent shall be installed in accordance with s. Comm 82.31 (5).

(b) *Offsets of more than 45°.* A drain stack with an offset of more than 45° from the vertical shall be installed in accordance with subds. 1. to 5.

1. That portion of the stack above the highest offset fitting shall be sized as for vertical drain piping in accordance with sub. (4).

2. That portion of the offset between and including the offset fittings shall be sized as horizontal drain piping in accordance with sub. (4).

3. That portion of stack below the offset shall be not less than the size of the offset and not less than the size required for vertical drain piping in accordance with sub. (4).

4. No horizontal branch drain may connect to the stack offset downstream from the offset's highest fitting within the distance equal to 10 pipe diameters of the offset.

5. Where an offset is located below 2 or more branch intervals, a relief vent and a yoke vent shall be installed in accordance with s. Comm 82.31 (5).

Note: See Appendix for further explanatory material.

(7) *HORIZONTAL BRANCH DRAIN CONNECTION AT BASE OF A STACK.* (a) A horizontal branch drain may not connect downstream from the base fitting of a drain stack 2 inches or larger in diameter within the distance equal to 10 pipe diameters of the drain to which the horizontal branch drain connects.

(b) A building drain branch or building subdrain branch may not connect to a building drain or building subdrain downstream from the base fitting of a drain stack 2 inches or larger in diameter within the distance equal to 20 pipe diameters of the building drain or building subdrain.

Note: See Appendix for further explanatory material.

(8) *PIPING CHANGES IN DIRECTION.* Changes in the direction of drain piping shall be accomplished in accordance with the requirements of this subsection.

(a) *Fittings.* All changes in direction of flow in drain piping shall be made by the appropriate use of 45 degree wyes, long or short sweep quarter bends, sixth, eighth, or sixteenth bends, or by a combination of these or other equivalent fittings. Except as provided in subds. 1. to 3., fittings which change the direction of flow for drain piping 8 inches or less in diameter shall conform to the minimum radii specified in Table 82.30-4.

Note: See Appendix for further explanatory material.

1. The minimum radius for the first 90° fitting downstream from a trap serving a lavatory or sink shall be 1-3/4 inches for drain piping 1-1/2 inches in diameter. The fitting shall be a tee or quarter bend.

2. The minimum radius for the first 90° bend or elbow downstream from a water closet shall be 2-1/2 inches for drain piping 3 inches in diameter.

3. The minimum radius for the first 90° bend or elbow downstream from a water closet shall be 3 inches for drain piping 4 inches in diameter.

Table 82.30-4

MINIMUM RADII OF FITTINGS (in inches)

Diameter of pipe (in inches)	Changes in Direction of Flow	
	Horizontal to Vertical	Vertical to Horizontal and Horizontal to Horizontal
1-1/4	1-1/8	2-1/4
1-1/2	1-3/8	2-3/4
2	1-7/8	3-1/4
3	2-7/8	4-1/16
4	3-3/4	4-7/8
5	4-1/2	6-1/2
6	5	7
8	6	8

(b) *Blowout type fixtures.* Where blowout type fixtures are installed back to back, appropriate fittings shall be installed to prevent the passage of wastes from one fixture to the other.

(9) **DRAIN FITTINGS AND CONNECTIONS.** Drain fittings, connections, devices and methods of installation shall not obstruct or retard the flow of water, wastes, sewage or air in the drain system or venting system in an amount greater than the normal frictional resistance to flow, unless as otherwise permitted in this chapter or unless approved by the department.

(a) *Closet bend.* The reduction of a 4 x 3 inch closet bend or collar fitting from 4 inches to 3 inches shall not be considered an obstruction.

(b) *Side inlet tees or bends.* The side inlet of a low pattern or high pattern tee or bend shall not be used as a vent connection when the side inlet is placed in a horizontal position or when any arrangement of piping or fittings produces a similar effect.

Note: See Appendix for further explanatory material.

(c) *Prohibited fittings and connections.* The types of fittings and connections specified in subds. 1. to 4. shall not be used for drain piping:

1. A heel inlet bend when the heel inlet is in the horizontal position;

2. A fitting or connection which has an enlargement chamber or recess with a ledge or shoulder, or reduction in pipe area in the direction of flow;

3. A fitting which has running threads; and

4. A connection by means of drilling and tapping of a drain or vent pipe, unless as otherwise approved by the department.

(d) *Saddles.* If a pipe saddle is used to connect drain piping together, the saddle shall be installed in accordance with s. Comm 84.30 (5) (d).

(10) **SUMPS, EJECTORS AND PUMPS.** (a) *Sumps.* 1. General. All sanitary building subdrains shall discharge into an approved, vented sump with an airtight cover. The sump shall be so located as to receive the sewage by gravity flow, and shall be located at least 25 feet from any water well.

2. Capacity. The minimum capacity of the sump shall be determined in accordance with the provisions of subd. 2. a. to e.

a. The water supply fixture unit method shall be used to determine peak input flow in gallons per minute; only the fixtures that drain to the sump shall be included.

Note: When converting water fixture units to gallons per minute it is permissible to calculate the load as a supply system with predominantly flush tanks.

b. The capacity of the sump shall be such that the pump when actuated by the lowest "pump on" switch runs at least 20 seconds.

c. Between the highest "pump on" switch level and the sump inlet, the sump shall hold the amount of input that exceeds the discharge of the pumping equipment in a 5 minute peak input period, but in no case shall the vertical distance between the switch and the inlet be less than 3 inches.

d. The low water level shall be maintained in accordance with the pump manufacturer's requirements, but shall not be less than 4 inches above the sump bottom.

e. Minimum sump diameter. Sumps containing one pump shall have an inside diameter of at least 24 inches. Sumps containing 2 pumps shall have an inside diameter of at least 30 inches.

Note: See Appendix for further explanatory material.

3. Vents. All sumps and all drains leading to a sump shall be vented in accordance with s. Comm 82.31.

4. Materials. All sumps shall be constructed in a watertight manner of approved materials in accordance with ch. Comm 84.

5. Removable covers. Penetrations through the top of removable sump covers shall be limited to those for the electrical supply, the vent piping and the discharge piping for the pump or pumps.

(b) *Ejectors and pumps.* 1. Where required. The liquid from all sanitary building sumps shall be lifted and discharged into the building sanitary drain system by automatic ejectors, pumps or any other equally efficient method approved by the department.

2. Duplex equipment. a. Duplex ejector or pumping equipment shall be installed in a public building where 3 or more water

closets or more than 20 drainage fixture units discharge into a sump.

b. Duplex ejector or pumping equipment shall be installed where the sanitary wastes of 2 or more one- or 2-family dwellings discharge into a sump.

c. Where duplex ejector or pumping equipment is installed, appropriate devices shall be installed to automatically alternate operation of the pumps or ejectors and to operate both pumps or ejectors when one unit cannot handle the load.

3. 'Size'. The size and design of an ejector or pump shall be determined by the capacity of the sump to be served, the discharge head and discharge frequency. All ejectors and pumps shall provide a minimum flow velocity of 2 feet per second in the forced discharge piping.

Note: Ejectors or pumps discharging to septic tanks may disturb the normal settling properties of the tank environment; contact the Safety and Buildings Division for more information.

a. All sewage grinder pumps shall have a minimum 1 $\frac{1}{4}$ inch diameter discharge opening and discharge piping.

b. All nongrinder-type sewage pumps serving water closets shall be capable of passing a 2 inch diameter solid ball and shall have a minimum 2 inch diameter discharge opening and discharge piping. All other pumps handling sanitary wastes shall be rated by the manufacturer as an effluent pump, shall be capable of passing a 1 $\frac{1}{2}$ inch diameter solid ball and shall have a minimum 1 $\frac{1}{4}$ inch diameter discharge opening and discharge piping.

4. Discharge connections. a. The discharge pipe from the ejector or pump shall be connected to the gravity drain by means of a wye pattern fitting. Where the fitting connects to a horizontal drain, the bottom of the wye branch of the fitting shall be located above the horizontal center line.

b. A full flow check valve shall be installed in the discharge piping from each ejector or pump.

c. Where duplicate ejector or pumping equipment is installed, each discharge pipe from an ejector or pump shall be provided with a gate or ball type valve installed downstream of each full flow check valve.

5. Discharge pipe air relief. Air relief valves shall be provided at all high points in the discharge piping of an ejector or pump where the piping arrangement creates an air trap.

6. Prohibited connections. No fixtures may be connected to the discharge pipe between the ejector or pump and the point where it enters the gravity drain.

7. Maintenance. All ejectors, pumps and like appliances shall receive care as needed to keep them in a satisfactory operating condition.

(11) **BUILDING DRAINS AND BUILDING SEWERS.** (a) *Limitations.* No building sewer may pass through or under a building to serve another building, unless:

1. The building sewer serves farm buildings or farm houses, or both, which are all located on one property; or

2. A petition for variance is granted under s. Comm 82.20 (11). The approval or nonapproval of a petition for variance request relative to this paragraph shall be determined on an individual basis. The request shall be evaluated on site specific factors including, at least, whether:

a. The building sewer serves buildings which are located on one property;

b. The functions or operations of the buildings to be served by the building sewer are related; or

c. A document, which indicates the piping and distribution arrangement for the property and buildings, will be recorded with the register of deeds.

(b) *Building drains.* 1. Elevation. a. All building drains shall be installed below the lowest floor levels on which fixtures may be installed if the public sewer, septic tank or private interceptor main sewer elevation permits.

b. Where any portion of an above-ground building drain discharges to a vertical pipe, the building drain shall connect to the building sewer at an elevation at least 30 inches above the basement floor.

Note: See Appendix for further explanatory material.

2. Backwater protection. A building drain subject to backflow or backwater shall be protected with a backwater valve or with a sump with pumping equipment in accordance with sub. (10).

a. Backwater valves, when fully open, shall have a capacity not less than that of the pipes in which installed.

b. Backwater valves shall be so located as to be readily accessible for cleaning.

3. Floor drain required. Where a plumbing fixture or appliance is located on a floor which is entirely below grade, a floor drain shall be installed to serve that floor.

(c) Building sewers. 1. Minimum depth. a. The top of a building sewer shall be located at a depth of not less than 42 inches below finished grade, except as provided in subd. 1. b. or subd. 2.

b. The top of a building sewer which discharges to a septic tank, holding tank or grease interceptor shall be located at a depth of not less than 18 inches below finished grade.

2. Protection from frost. a. Except as provided in subd. 2. c. and d., a building sewer shall be protected from frost in accordance with subd. 3. in areas where the top of the building sewer

is located less than 60 inches below a surface area from which snow will be cleared.

b. Except as provided in subd. 2. c. and d., a building sewer shall be protected from frost in accordance with subd. 3. in areas where the top of the building sewer is located less than 42 inches below a surface which snow will not be cleared.

c. Where a building sewer discharges to a septic tank, holding tank, or grease interceptor, the portion of a building sewer which is within 30 feet from the connecting building drain and which is under a surface area from which snow will not be cleared shall not be required to be protected from frost.

d. Frost protection for a building sewer shall not be required where the predicted depth of frost as determined from Figure 82.30-1 and Table 82.30-6 does not extend below the top of the building sewer.

3. Insulations for building sewers. Where required by subd. 2. a. or b., building sewer insulation for frost protection shall be provided in accordance with one of the methods specified in subd. 3. a. to c.

a. Extruded polystyrene foam insulation shall be installed at a depth of at least 18 inches below finished grade and at least 6 inches above the top of the sewer pipe. The minimum thickness and width of the foam insulation shall be determined from Figure 82.30-1 and Tables 82.30-5 to 82.30-7. If the insulation is to be installed more than 6 inches above the top of the sewer, the number of inches exceeding 6 inches shall be added to the width of insulation determined from Table 82.30-7.

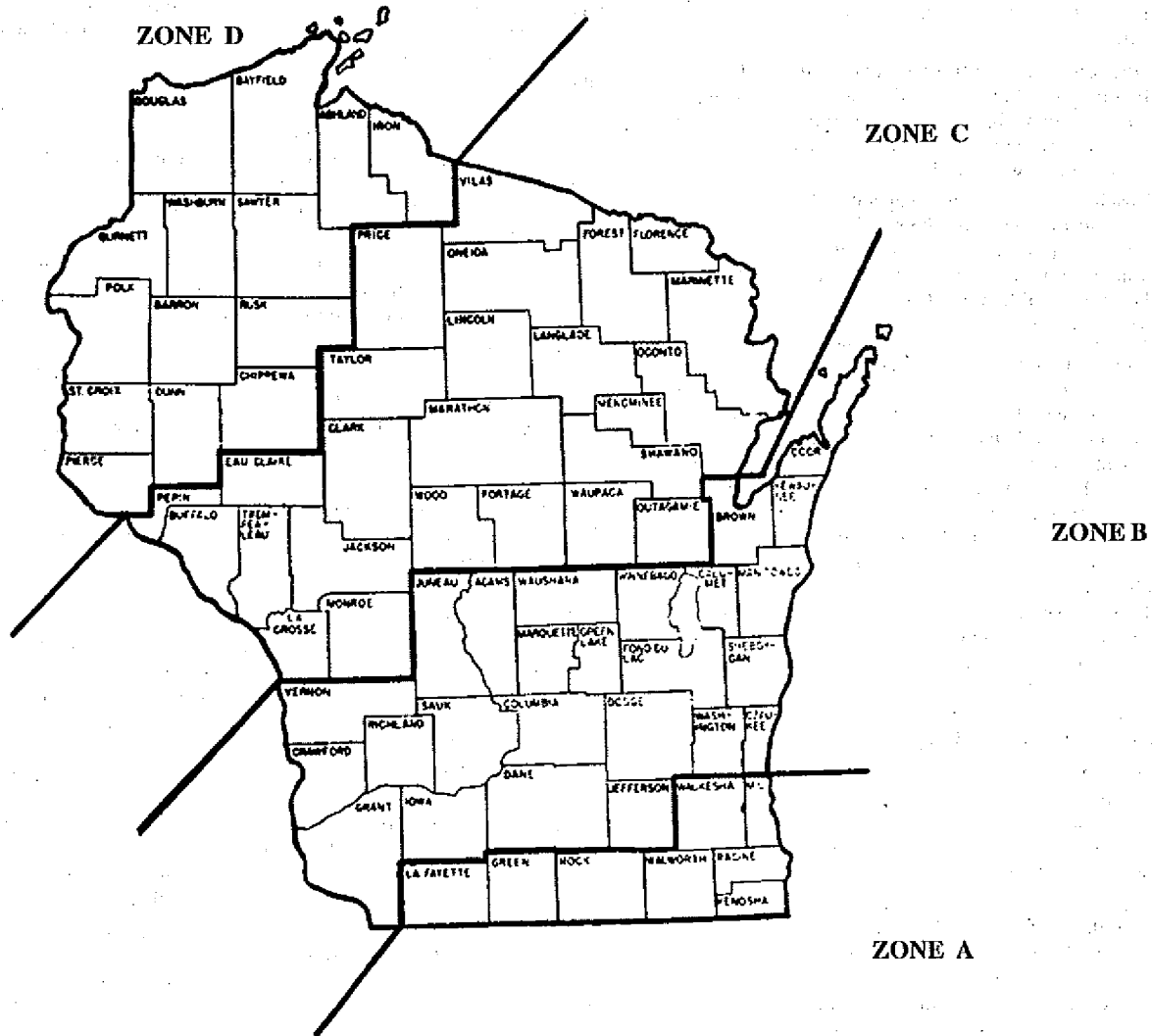

Table 82.30-5
MINIMUM THICKNESS OF INSULATION

Installation Site Zone	Extruded Polystyrene Foam (in inches)	Insulating Concrete (in inches)
A	1.0	6
B	1.5	9
C	2.0	12
D	2.5	15

Table 82.30-6
PREDICTED DEPTH OF FROST IN VARIOUS TYPES OF BACKFILL SOIL (in feet)

Soil Type	Installation Site Zone			
	A	B	C	D
Clay, Clay Loam	2.5	3.0	3.5	4.0
Silt Loam, Silty Clay Loam	3.5	4.0	4.5	5.5
Sandy Clay Loam	4.0	4.5	5.5	6.0
Sandy Loam, Loamy Sand	4.5	5.0	6.0	6.5
Sand	5.0	5.5	6.5	7.5
Gravelly Sand	6.0	7.5	9.0	10.0

b. Lightweight insulating concrete shall be installed to the depth of the spring line of the sewer and shall extend laterally at least 6 inches on both sides of the sewer. The minimum thickness of the insulating concrete shall be determined from Figure 82.30-1 and Table 82.30-5. The thickness shall be measured from the top of the sewer. The top of the insulation shall be installed at least 12 inches below finished grade.

c. Alternative methods of frost protection shall be approved by the department.

(d) *Location limitations.* Building drains and building sewers shall be separated from water wells by the following minimum distances:

1. Eight feet for building drains and building sewers of cast iron pipe;
2. Eight feet for building drains and building sewers of plastic pipe;
3. Twenty-five feet for building drains and building sewers of all other materials; and
4. Twenty-five feet for all pressurized building drains and building sewers.

Note: See s. Comm 82.40 for provisions regarding the separation of water supply piping and building sewer piping.

(e) *Installation of building drains and building sewers.* 1. Trenching. All excavations for building drains and building sewers shall be open trench work, unless otherwise permitted by local ordinance or accepted by the local inspector.

2. Stable bottom. Where the bottom of the trench can be maintained in a stable condition and free of water during the time of installation the building drain and the building sewer shall be bedded and initially backfilled as specified in this subdivision. Grade, as used in this subdivision, shall mean the elevation of the bottom of the building drain or the building sewer.

a. Except where sand is encountered, the trench bottom throughout its length shall be excavated to a depth at least 3 inches below the grade elevation and shall be brought back to grade with sand, pea gravel, or a graded stone bedding. The bedding material shall be of a size that all the material shall pass a $\frac{3}{4}$ inch sieve. When sand is used as a bedding material it shall not contain excessive moisture and the bedding in the entire trench width shall be hand or mechanically tamped to compact it to a minimum of 90% Standard Proctor Density. All bedding shall be shaped to accommodate pipe bells or couplings. Initial backfill on the sides of the

pipe and to a depth of 12 inches over the pipe shall be sand, gravel, crushed stone or excavated material which is neither corrosive nor organic in nature. A concrete floor may be placed over a building drain having less than 12 inches of initial backfill. Initial backfill material shall be of a size that all the material shall pass a one inch sieve. Initial backfill material shall be placed in increments not exceeding 6 inches in depth and shall be well tamped for the full width of the trench and for the full length of the sewer.

b. Where the trench bottom does not contain stone larger than one inch in size or where bedrock is not encountered, the trench may be excavated to grade. Where stone larger than one inch in size or when bedrock is encountered, the trench shall be excavated to a depth at least 3 inches below the grade elevation and shall be brought back to grade with a bedding of sand, gravel, or crushed stone which shall be of a size that all the material shall pass a $\frac{3}{4}$ inch sieve. The bedding material shall be shaped to accommodate the pipe bells or couplings. Initial backfill on the sides of the pipe and to a depth of 3 inches over the pipe for that part of the pipe laid on private property shall be well tamped sand, gravel, crushed stone or excavated material which is neither corrosive nor organic in nature. A concrete floor may be placed over a building drain having less than 3 inches of initial backfill. Initial backfill material shall be of a size that all the material shall pass a one inch sieve. For that portion of the sewer in the street right of way, the initial backfill material to a depth of 12 inches over the pipe shall be sand, gravel or crushed stone which shall be of a size that all the material shall pass a one inch sieve. Initial backfill material shall be placed in increments not exceeding 6 inches and shall be well tamped.

3. Unstable bottom. Where a mucky or unstable bottom is encountered in the trench, the required dry and stable foundation conditions shall be provided by sheathing driven and left in place to a depth of 48 inches below the trench bottom or to solid foundation at a lesser depth, the removal of wet and yielding material to a depth of 24 inches or to solid material, and replacement of the unstable material with limestone screenings, pea gravel or equivalent material for the bedding under the pipe. The trench bedding shall be shaped to accommodate pipe bells or couplings. In lieu of the foregoing, the required dry and stable foundation conditions may be provided by installation of a longitudinally reinforced concrete cradle the width of the trench and at least 3 inches thick or by installation of a longitudinally reinforced concrete slab the width of the trench at least 3 inches thick and bedding material as provided for in subd. 2. Initial backfill material and its placement

shall conform to that specified in subd. 2. All sheathing shall be cut off at a depth of 3 feet or more below the ground surface to prevent heaving due to frost action.

4. Backfill completion. Care shall be exercised in placing the

balance of the backfill to prevent breakage of the pipe. Large boulders or rock, concrete slabs, or frozen masses shall not be used in the backfill. At least 36 inches of backfill cover shall be provided over the top of the pipe before the pipe trench is wheel-loaded.

Table 82.30-7

MINIMUM WIDTH OF EXTRUDED POLYSTYRENE FOAM INSULATION (in feet)

Predicted Depth of Frost (in feet)	Depth of Sewer (in feet)					
	2.0	2.5	3.0	3.5	4.0	4.5
2.5	2	NR				
3.0	3	2	NR			
3.5	4	3	2	NR		
4.0	5	4	3	2	NR	
4.5	6	5	4	3	2	NR
5.0	7	6	5	4	3	2
5.5	8	7	6	5	4	3
6.0	9	8	7	6	5	4
6.5	10	9	8	7	6	5
7.0	10	10	9	8	7	6
7.5	10	10	10	9	8	7
8.0	10	10	10	10	9	8
8.5	10	10	10	10	10	9
9.0	10	10	10	10	10	10
10.0	10	10	10	10	10	10

NR means Not Required.

5. Pipe openings protected. The ends of all pipes not immediately connected shall be closed so as to prevent the introduction of earth or drainage from an excavation.

(f) *Connection to public sewer.* The connections of building sewers to public sewers shall be in accordance with conditions of approval for the public sewer granted by the department of natural resources under s. 281.41, Stats.

1. Gravity public sewer. When a building sewer connection to the public sewer is not found within 3 feet of the point designated by the local governing body or its authorized representative, the connection shall be made in accordance with one of the provisions specified in subd. 1. a. to d.

a. A saddle fitting approved by the department and acceptable to the municipality or sanitary district shall be installed.

b. Where acceptable to the municipality or sanitary district a portion of the main sewer may be removed and a tee or wye fitting approved by the department may be inserted with compression joints in the public sewer acceptable to the municipality or the sanitary district. The insertion shall be made under the supervision of the authorized representative of the municipality or the sanitary district.

c. When the public sewer is concrete or clay, the end of the connecting sewer may be set upon or in an opening cut into the top half of the public sewer, but shall not protrude into the public sewer. The connection shall be secured by encasing the main sewer pipe and the connection in concrete at least 3 inches thick so as to assure permanency of the connection and adequate backing of the public sewer pipe.

d. In lieu of the use of a fitting and in the event that an opening cannot be located in the top half of the public sewer, a length of concrete or clay public sewer pipe may be removed and a section with a wye fitting shall be inserted in its place. The joints at the ends of the section shall be encased in concrete at least 3 inches thick. The connection or insertion shall be made under the super-

vision of the authorized representative of the municipality or the sanitary district.

2. Pressurized public sewer. Where a forced building sewer discharges to a pressurized public sewer, a full flow corporation cock, full flow curb stop, check valve and dresser type coupling shall be installed. The curb stop, check valve and dresser type coupling shall be installed on the property as close as possible to the connection to the common forced main sewer. The check valve and dresser type coupling shall be accessible.

Note: See Appendix for further explanatory material.

(g) *Prohibited installations.* 1. Harmful discharge. No person may connect to a public sewer any building drain or building sewer through which is discharged any substance likely to cause undue corrosion, obstruction, nuisance, explosion or interference with sewage treatment processes.

2. Storm and clear water connections. Storm drain piping and clear water drain piping may not discharge to a sanitary building drain or to a private sewage system.

Note: See s. Comm 82.36 for provisions relative to storm sewers.

(12) PRIVATE INTERCEPTOR MAIN SEWERS. (a) The connection of a private interceptor main sewer to a public sewer shall be in accordance with the conditions of approval for the public sewer granted by the department of natural resources under s. 144.04, Stats.

(b) Private interceptor main sewers which discharge to a municipal treatment facility shall be designed in accordance with the appropriate water quality management plan.

(c) All private interceptor main sewers shall be tested in accordance with s. Comm 82.21.

(d) Private interceptor main sewers 6 inches or less in diameter shall be installed in accordance with the criteria for building sewers specified in sub. (11) (b) and (c) and (d) and (e).

(e) Private interceptor main sewers 8 inches or larger in diameter shall be:

1. Provided with frost protection in accordance with sub. (11) (c); and

2. Installed in accordance with the municipal sewer criteria specified in s. NR 110.13.

(f) No private interceptor main sewer may pass through or under a building to serve another building, unless:

1. The private interceptor main sewer serves farm buildings or farm houses or both which are all located on one property; or

2. A petition for variance is granted under s. Comm 82.20 (11). The approval or nonapproval of a petition for variance request relative to this paragraph shall be determined on an individual basis and shall be evaluated on site specific conditions including, at least, whether:

a. The private interceptor main sewer serves only buildings which are all located on one property;

b. The functions or operations of the buildings to be served by the interceptor main sewer are related; or

c. A document, which indicates the piping and distribution arrangement for the property and buildings, will be recorded with the register of deeds.

(13) LOCATION OF DRAIN PIPING. (a) Drain piping located below the ceilings of areas where food, ice or potable liquids are prepared, handled, stored or displayed shall be installed with the least number of joints and shall be installed in accordance with subs. 1. to 5.

1. All pipe openings through floors shall be provided with sleeves bonded to the floor construction and protruding not less than one inch above the top of the finish floor with the space between sleeve and the piping sealed.

2. Plumbing fixtures, except bathtubs and showers, shall be of the wall mounted type. Bathtubs shall have waste and overflow connections made above the floor and piped to a trap below the floor.

3. Floor and shower drains installed shall be equipped with integral seepage pans.

4. Cleanouts for piping shall be extended through the floor construction above.

5. Piping subject to operation at temperatures that will form condensation on the exterior of the pipe shall be thermally insulated.

(b) Where drain piping is located in ceilings of areas where food, ice or potable liquids are prepared, handled stored or displayed, the ceilings shall be of the removable type, or shall be provided with access panels in order to provide an access for inspection of the piping.

(c) Exposed drain piping shall not be located over a pool, surge tank or an open filter for a pool.

History: Cr. Register, February, 1985, No. 350, eff. 3-1-85; am. Table 82.30-1, (8) (a), (9) (c) (intro.) and 3., and (10) (b) 3. b., r. and recr. (4) (d) 2., Table 82.30-4, (10) (a) 2. b., (11) (intro.) and (f) 2., cr. (8) (a) 1. to 3. and (9) (d), r. (9) (c) 4., renum. (9) (c) 5. to be 4. and am., Register, May, 1988, No. 389, eff. 6-1-88; r. and recr. (4) (d), am. Table 82.30-3 and 82.30-7, r. (11) (intro.), renum. (11) (a) to (f) to be (b) to (g), cr. (11) (a) and (12) (f), Register, August, 1991, No. 428, eff. 9-1-91; am. Table 82.30-1, Register, April, 1992, No. 436, eff. 5-1-92; am. (7) (a) and (b), (11) (c) 1. a., (12) (e) 1. and Table 82.30-1, cr. (10) (a) 5., r. (11) (b) 1. b., renum. (11) (b) 1. c. to be (11) (b) 1. b., Register, February, 1994, No. 458, eff. 3-1-94; reprinted to restore dropped copy in (10) (b) 3. b., Register, July, 1994, No. 463.

Comm 82.31 Vents and venting systems. (1) SCOPE. The provisions of this section set forth the requirements for the design and the installation of vents and venting systems.

(2) MATERIALS. All vents and venting systems shall be constructed of approved materials in accordance with ch. Comm 84.

(3) GENERAL. (a) Vents. Every trap and trapped plumbing fixture shall be provided with an individual vent, except as otherwise permitted in this chapter. Vents and venting systems shall be

designed and installed so that the water seal of a trap shall be subject to a maximum pneumatic pressure differential equal to one inch of water column.

(b) Main stack. Each gravity-flow sanitary building sewer shall be served by at least one stack which extends from a building drain to a vent terminal or vent header. The stack shall be not less than 3 inches in diameter from the building drain to the vent terminal or vent header.

(4) VENT STACKS AND STACK VENTS. (a) Where required. Where individual vents, relief vents, or other branch vents are required, a vent stack and a stack vent shall be installed to serve all drain stacks of 2 or more branch intervals.

(b) Installation. 1. The connection of the vent stack to a drain stack shall be at or below the lowest branch drain connection to the drain stack. The connection to the drain stack shall be by means of a wye pattern fitting installed in a vertical portion of the stack.

2. A vent stack and a stack vent shall:

a. Extend to a vent terminal in accordance with sub. (16);

b. Connect to a vent stack which extends to a vent terminal; or

c. Connect to a stack vent at least 6 inches above the flood level rim of the highest fixture discharging into a drain stack.

3. Vent stacks and stack vents may connect into a common vent header and then shall extend to a vent terminal.

4. The connection of a vent stack with another vent may not be less than 38 inches above the next higher floor level where the plumbing fixtures are vented, but in no case lower than 2 inches above the elevation of the highest flood level rim of any fixture served by the vent.

Note: See Appendix for further explanatory material.

(5) RELIEF AND YOKE VENTS FOR STACK OFFSETS. (a) Offsets of 30 to 45°. Where a horizontal branch drain connects to a drain stack within 2 feet above or below a stack offset with a change of direction of 30 to 45° from the vertical and the offset is located below 2 or more branch intervals, a relief vent shall be installed in accordance with par. (c), except where an offset of more than 45° from the vertical is located in the drain stack within 12 feet above the offset of 30 to 45°.

(b) Offsets of more than 45°. Except as provided in subs. 1. and 2., where a drain stack has an offset of more than 45° from the vertical located below 2 or more branch intervals, a relief vent and a yoke vent shall be installed in accordance with par. (c).

1. Where an offset of more than 45° from the vertical is located in the drain stack within 12 feet above the lower stack offset, the installation of a yoke vent shall not be required.

2. Where the offset of more than 45° is located below the lowest branch drain connection, the installation of the relief vent shall not be required.

(c) Installation. 1. Relief vent. a. A relief vent serving a drain stack offset shall be installed as a vertical continuation of the portion of the stack below the offset or as a side connection to the portion of the stack below the offset. No drain connection may be installed between the offset and the side connection of the relief vent.

b. The connection of the relief vent to the drain stack shall be by means of a wye pattern fitting.

c. The connection of a relief vent with another vent may not be less than 38 inches above the next higher floor level where the plumbing fixtures are vented, but in no case lower than 2 inches above the elevation of the highest flood level rim of any fixture served by the vent.

2. Yoke vent. a. A yoke vent serving a drain stack offset shall connect to the drain stack at or below the lowest branch drain connection to the portion of the drain stack above the offset.

b. The connection of the yoke vent to the drain stack shall be by means of a wye pattern fitting.

c. The connection of the yoke vent to another vent may be not less than 38 inches above the next higher floor level where plumbing fixtures are installed that discharge into the drain stack.

Note: See Appendix for further explanatory material.

(6) YOKE VENTS FOR STACKS OF MORE THAN 10 BRANCH INTERVALS. Drain stacks of more than 10 branch intervals shall be provided with yoke vents.

(a) Yoke vents shall be installed not more than 10 branch intervals apart nor more than 10 branch intervals from the top or bottom of the drain stack.

(b) The connection of the yoke vent to the drain stack shall be by means of a wye pattern fitting.

(c) The connection of the yoke vent to another vent shall be not less than 38 inches above the next higher floor level where plumbing fixtures are installed that discharge into the drain stack.

(7) RELIEF VENTS FOR BUILDING DRAINS. A building drain with a change in elevation of 12 feet or more and at an angle of 45° or more from the horizontal shall be provided with a relief vent.

(a) The connection of the relief vent to the building drain shall be by means of a wye pattern fitting installed within 2 feet upstream of the top of the change in elevation.

(b) The connection of the relief vent to another vent shall be not less than 38 inches above the next higher floor level where plumbing fixtures are installed that discharge through the building drain.

Note: See Appendix for further explanatory material.

(8) VENTS FOR SANITARY SUMPS. Sanitary sumps shall be provided with a vent connecting either to the sump above the drain inlet or to the drain inlet within 12 inches of the sump.

(9) FIXTURE VENTS. (a) *Developed length between vent and trap.* Each fixture trap shall be protected with a vent located in accordance with the provisions of subds. 1. and 2.

1. Each fixture trap which is not an integral part of the fixture shall be protected with a vent so located that the developed length of the fixture drain piping from the trap weir to the vent connection is within the limits set forth in Table 82.31-1.

2. Each fixture trap which is an integral part of the fixture shall be protected with a vent so located that the developed length of the fixture drain piping from fixture outlet to the vent connection is within the limits set forth in Table 82.31-1. For a floor outlet water closet or similar fixture, the point where the fixture drain piping turns horizontal shall be considered as the fixture outlet.

Table 82.31-1

MAXIMUM DEVELOPED LENGTH BETWEEN VENT AND TRAP (in feet)

Diameter of Fixture Drain ^a (in inches)	Vent Connecting to Horizontal Drain Piping			Vent Connecting to Vertical Drain Piping					
				by means of a Sanitary Tee Fitting			by means of a Wye Pattern Fitting ^b		
	Pitch of Fixture Drain (inch per foot)			Pitch of Fixture Drain (inch per foot)			Pitch of Fixture Drain (inch per foot)		
	1/8	1/4	1/2	1/8	1/4	1/2	1/8	1/4	1/2
1 1/4	NP ^c	5.0	2.5	NP	3.5	2.0	NP	1.5	1.0
1 1/2	NP	6.0	3.0	NP	5.0	3.0	NP	4.0	2.0
2	NP	8.0	4.0	NP	6.0	4.0	NP	4.5	4.0
3	24	12.0	6.0	10.0	8.0	6.0	8.0	6.0	6.0
4 ^d	32	16.0	8.0	12.0	10.0	8.0	10.0	8.0	8.0

a: Diameters to be selected on the basis of the smallest drain pipe installed downstream from the trap serving a particular fixture.

b: The wye pattern fitting refers to a tee-wye fitting, a combination wye and eighth bend fitting or a wye and eighth bend combination of fittings with no more than one inch between the wye fitting and eighth bend fitting.

c: NP means Not Permitted.

d: The maximum developed length for fixture drains larger than 4 inches in diameter shall be approved by the department.

(b) *Minimum distance.* A vent shall not connect to a fixture drain within the distance equal to 2 diameters of the drain piping from the weir of a trap.

Note: See Appendix for further explanatory material.

(10) CIRCUIT VENTING. In lieu of providing individual vents, a horizontal drain to which at least 2 but not more than 8 wall outlet fixtures or at least 2 but not more than 8 floor outlet fixtures, other than blowout type fixtures and wall-outlet carrier type water closets, are connected to the same horizontal branch drain, may be vented by a circuit vent in accordance with pars. (a) to (e).

(a) The circuit vent shall connect to the horizontal drain at a point between the 2 most upstream fixtures.

(b) 1. A circuit vented horizontal drain into which 4 or more fixtures discharge shall be provided with a relief vent. The relief vent shall connect to the circuit vented horizontal drain downstream of the most downstream fixture drain which is vented by the circuit vent and upstream of any other drain connections.

2. Two circuit vented horizontal drains serving a total of 8 fixtures, 4 on each branch, shall be provided with at least one relief vent, unless the horizontal drains connect to a drain stack with no other drain connections located above the circuit vented horizontal drains. One relief vent may serve both horizontal drains, if installed downstream of the point where the 2 horizontal drains are joined.

Note: See Appendix for further explanatory material.

(c) A horizontal drain served by a circuit vent shall not diminish in size from the connection to the drain stack to the circuit vent connection. Where a relief vent is installed, the horizontal drain served by the circuit vent shall not diminish in size from the relief vent connection to the circuit vent connection.

(d) Fixture drains served by a circuit vent shall conform to the provisions of sub. (9). The connection of the fixture drain to the branch drain served by the circuit vent shall be considered as the vent connection.

(e) Additional wall outlet fixtures with a drainage fixture unit value of one or less which are served by individual vents or common vents may discharge into a horizontal drain served by a circuit vent.

(11) COMMON VENTS. In lieu of providing individual vents, fixtures may be common vented in accordance with pars. (a) and (b).

(a) *Vertical drains.* A common vent may serve 2 fixture traps where both fixture drains connect to a vertical drain at the same elevation. Where this connection is by means of a sanitary tee fitting with a side inlet, the centerline of the side inlet opening may not be below the centerline of the larger opening. The drain connection of a blowout type fixture or a kitchen sink served by a common vent may not be by means of a double sanitary tee fitting.

(b) *Horizontal branches.* The fixture drains from 2 wall-outlet fixtures, each with a drainage fixture unit value of one or less, or the fixture drains from 2 traps serving a kitchen sink with or without a dishwasher may connect to a horizontal branch without individual vents provided a common vent connects to the branch drain downstream of both fixture drains. Both fixture drains shall be of the same diameter. The developed length of the drain from the vent to the farthest trap shall conform to sub. (9).

Note: See Appendix for further explanatory material.

(12) **ISLAND FIXTURE VENTING.** Island plumbing fixtures may be vented in accordance with pars. (a) to (d).

(a) Island plumbing fixtures may be vented by extending an individual vent or a common vent as high as possible under the fixture enclosure and returning the vent vertically downward and connecting it to the fixture drain by means of a wye pattern fitting.

(b) Horizontal vent piping shall connect to the vertical section of the fixture vent and extend to a point where it can extend vertically to a vent terminal in accordance with sub. (16) or connect to another vent in accordance with sub. (15).

(c) Drainage fittings shall be used on all sections of the vent pipe below the floor level and a minimum slope of $\frac{1}{4}$ inch per foot to the drainage point shall be provided.

(d) Cleanouts shall be provided on the vent piping in accordance with s. Comm 82.35.

Note: See Appendix for further explanatory material.

Note: See sub. (17) for venting provisions relating to laboratory sinks.

(13) **WET VENTING.** In lieu of providing individual vents, fixtures may be wet vented in accordance with pars. (a) to (c).

(a) *Vertical wet vents.* 1. Where 2 wall outlet fixtures are located on the same floor level with their fixture drains connecting to the same vertical drain pipe at different elevations, the lower fixture drain may be wet vented in accordance with subd. 1. a. to e.

a. No other fixtures may discharge into the vertical drain pipe above or between the 2 wall outlet fixtures. Additional fixtures may discharge into the vertical drain pipe below the 2 wall outlet fixtures.

b. A branch vent shall connect to the vertical drain pipe immediately above the higher fixture drain connection.

c. The drain between the 2 fixtures shall be at least one pipe size larger than the upper fixture drain, but not smaller than 2 inches in diameter.

d. Both fixture drains shall conform to sub. (9). The connection of the lower fixture drain to the vertical drain shall be considered as the vent connection.

e. The higher fixture drain may not serve a water closet or urinal.

Note: See Appendix for further explanatory material.

(b) *Horizontal wet vents.* A drain from a lavatory or lavatories which are either provided with individual vents or a common vent may serve as the wet vent for not more than 2 bathtubs or showers and not more than 2 water closets in accordance with subds. 1. to 7. No other fixtures may discharge into or be served by the wet vent.

1. All of the fixtures shall be located in nonpublic bathroom groups.

2. The lavatories and bathtubs or showers shall have a common horizontal drain with the drain for the lavatories serving as a wet vent for the bathtubs or showers.

3. Where 2 bathtubs or showers are served by the same wet vent, their fixture drains shall connect independently to the common horizontal drain downstream of the vertical drain serving the lavatory or lavatories.

4. Where 2 bathtubs or showers and 2 water closets are served by the same wet vent a relief vent shall be provided, unless the wet vented horizontal drain connects to a drain stack with no other drain connections located above the wet-vented horizontal drain.

The relief vent shall connect to the horizontal drain at a point downstream of the fixture drains for the water closets and upstream of any other fixture drain connections.

5. One or 2 water closets may connect to the common horizontal drain with the drain from the lavatories and bathtubs or showers also serving as a wet vent for the water closets. Where 2 water closets are served by the same wet vent, their fixture drains shall connect independently to the common horizontal drain at the same point.

6. The wet vent shall be at least 2 inches in diameter. No more than 4 drainage fixture units may discharge into a 2 inch diameter wet vent.

7. A branch vent shall connect immediately above the highest fixture drain connection and shall be sized in accordance with sub. (14).

(c) *Other types of wet vents.* An individual vent serving a floor outlet fixture, a common vent serving floor outlet fixtures, a circuit vent, a relief vent serving a circuit vented drain or a relief vent serving a wet vented horizontal drain may serve as a wet vent in accordance with subds. 1. to 4.

1. No more than 2 wall outlet fixtures, each fixture with a drainage fixture unit value of one or less, may have their fixture drains connected individually into the individual vent, common vent, circuit vent or relief vent thereby forming a wet vent.

2. The wet vent shall be at least 2 inches in diameter.

3. The branch vent to which the wet vent connects shall be sized in accordance with sub. (14). The branch vent may serve the wall outlet fixtures in lieu of individual vents or a common vent.

4. The fixtures discharging into the wet vent shall be located on the same floor level as the fixtures served by the wet vent.

(14) **VENT SIZE.** (a) *Stack vents and vent stacks.* Stack vent and vent stack pipe sizes shall be determined in accordance with Table 82.31-2 on the basis of developed length and the diameter of the drain stack at its base.

1. The developed length of the stack vent shall be measured along the vent pipe, from the highest drain branch connection to the vent terminal or to the connection to a vent header.

2. The developed length of the vent stack shall be measured along the vent pipe from the vent stack base connection to the vent terminal or to the connection to a vent header.

Note: See Appendix for further explanatory material.

(b) *Vent headers.* 1. Vent header pipe sizes shall be determined in accordance with Table 82.31-3 with the number of drainage fixture units being the sum of the fixture unit loads of the stacks vented through that portion of the header. The diameter of a vent header shall not be less than any vent connecting to it.

2. The developed length of the vent header shall be measured along the pipe from the most distant vent stack or stack vent base connection to the vent terminal.

Note: See Appendix for further explanatory material.

(c) *Branch vents.* Branch vent pipe sizes shall be determined in accordance with Table 82.31-3. The developed length of the branch vent shall be measured along the pipe from the furthest fixture drain served by the branch vent to the point where it connects to a vent pipe of a larger diameter or to a vent terminal.

Note: See Appendix for further explanatory material.

(d) *Individual vents.* Individual vent pipe sizes shall be determined in accordance with Table 82.31-3. The developed length of an individual vent shall be measured along the vent pipe from the fixture drain served by the vent to the point where it connects to a vent pipe of a larger diameter or to a vent terminal.

Note: See Appendix for further explanatory material.

(e) *Common vents.* Common vent pipe sizes shall be determined in accordance with Table 82.31-3. The developed length of a common vent shall be measured along the vent pipe from the drain served by the vent to the point where it connects to a vent pipe of a larger diameter or to the vent terminal.

Table 82.31-2
SIZE AND LENGTH OF VENT STACKS AND STACK VENTS

Diameter of Drain Stack at Base (inches)	Maximum Developed Length of Vent (feet)									
	Diameter of Vent (inches)									
	1/4	1/2 ^a	2	3	4	5	6	8	10	12
1 1/2	50	150	NL ^b							
2	NP ^c	50	150	NL						
3		NP	50	400	NL					
4		NP	20	180	700	NL				
5			NP	50	200	700	NL			
6			NP	20	70	200	700	NL		
8				NP	25	60	250	800	NL	
10					NP	25	60	250	800	NL
12						NP	25	100	300	900

a: Not more than 2 water closets or similar flush action type fixtures of 4 or more drainage fixture units.
 b: NL means No Limit.
 c: NP means Not Permitted.

Table 82.31-3
MINIMUM DIAMETERS AND MAXIMUM LENGTH OF INDIVIDUAL, COMMON, BRANCH AND CIRCUIT VENTS AND VENT HEADERS

Drainage Fixture Units (dfu)	Maximum Developed Length of Vent (feet)								
	Diameter of Vent (inches)								
	1 1/4 ^a	1 1/2 ^b	2	3	4	5	6	8	10
2	50	NL ^c							
4	40	200	NL						
8	NP ^d	150	250	NL					
10	NP	100	200	NL					
24	NP	50	150	NL					
42	NP	30	100	500	NL				
72		NP	50	400	NL				
240		NP	40	250	NL				
500		NP	20	180	700	NL			
1100			NP	50	200	700	NL		
1900			NP	20	70	200	700	NL	
3600				NP	25	60	250	800	NL
5600					NP	25	60	250	800

a: No water closets permitted.
 b: Not more than 2 water closets or similar flush action type fixtures of 4 or more drainage fixture units.
 c: NL means No Limit.
 d: NP means Not Permitted.

(f) *Circuit vents.* Circuit vent pipe sizes shall be determined in accordance with Table 82.31-3. The developed length of the circuit vent shall be measured along the vent from the connection with the branch drain served by the vent to the point where it connects to a vent pipe of a larger diameter or to a vent terminal.

(g) *Relief vents.* Relief vents shall be sized in accordance with the provisions of subs. 1. to 4. The developed length of a relief vent shall be measured along the vent from the connection with the branch drain served by the vent to the point where it connects to a vent pipe of a larger diameter or to a vent terminal.

1. *Circuit vented branch drain.* The diameter of a relief vent for a branch drain served by a circuit vent shall be at least one half the diameter of the branch drain. The maximum developed length

shall be determined from Table 82.31-3 based on the number of drainage fixture units served by the vent.

2. *Drain stacks.* A relief vent serving a drain stack shall be sized as a stack vent in accordance with par. (a).

3. *Building drain.* The diameter of a relief vent serving a building drain, as required in sub. (7), shall be at least one half the diameter of the building drain. The maximum developed length shall be determined from Table 82.31-3 based on the number of drainage fixture units served by the vent.

4. *Horizontal wet vent.* The diameter of a relief vent serving a horizontal wet vent shall be at least 1 1/2 inches. The maximum developed length shall be determined from Table 82.31-3 based on the number of drainage fixture units served by the vent.

(h) *Yoke vents.* A yoke vent serving a drain stack shall be sized as a vent stack in accordance with par. (a).

(i) *Vents for sumps.* 1. a. Except as provided in subd. 1. b., the size of a vent for a sanitary pump with other than a pneumatic ejector, shall be determined in accordance with Table 82.31-4.

b. The size of a vent for a sanitary sump located outside with other than a pneumatic ejector shall be determined in accordance with Table 82.31-4, but shall not be less than 2 inches in diameter.

2. The air pressure relief pipe from a pneumatic ejector shall not be connected to vent or vent system serving a sanitary drain system, storm drain system or chemical waste system.

a. The relief pipe shall be of a size to relieve the air pressure inside the ejector to atmospheric pressure, but shall not be less than 2 inches in diameter where the ejector is located outside and 1 1/4 inches in diameter for all other ejector locations.

b. The vent shall terminate in accordance with the provisions of sub. (16).

(15) **VENT GRADES AND CONNECTIONS.** (a) *Vent grade.* All vent and branch vent pipes shall be graded and connected so as to drain back to a drain pipe by means of gravity.

(b) *Installation.* Vents shall be installed in accordance with subds. 1. to 3.

1. Except for wet vent piping, the connection of a vent to horizontal drain piping shall be at a point above the horizontal center line of the drain piping.

(a) *Extension above roofs.* Extensions of vents through a roof shall terminate at least 8 inches above the roof. Where the roof is to be used for any purpose other than weather protection, the vents shall extend at least 7 feet above the roof.

(b) *Waterproof flashings.* The penetration of a roof system by a vent shall be made watertight with an approved flashing.

(c) *Prohibited uses.* Vent terminals shall not be used as flag poles, support for antennas or other similar purposes.

(d) *Location of vent terminals.* 1. A vent shall not terminate under the overhang of a building.

2. All vent terminals shall be located:

a. At least 10 feet from an air intake;

b. At least 5 feet from a power exhaust vent;

c. At least 10 feet horizontally from or 2 feet above roof scuttles, doors and openable windows; and

d. At least 5 feet from or 2 inches above parapet walls.

3. Where a structure has an earth covered roof extending from surrounding grade, the vent extension shall run at least 7 feet above grade and terminate with an approved vent cap. The portion of vent pipe outside the structure shall be without joints, except one fitting may be installed where the pipe leaves the top or side of the structure.

(e) *Extension through wall.* Where approved by the department, a vent may terminate through an exterior wall. Such a vent shall terminate at least 10 feet horizontally from any lot line and shall terminate downward. The vent shall be screened and shall comply with par. (d).

(f) *Extensions outside buildings.* Drain or vent pipe extensions shall not be located or placed on the outside of an exterior wall of any new building, but shall be located inside the building.

(g) *Frost closure.* For protection against frost closure, each vent terminal shall be at least 2 inches in diameter. Where it is necessary to increase the diameter of the vent, the change in diameter shall be made at least 6 inches inside the building.

Note: See Appendix for further explanatory material.

(17) **COMBINATION DRAIN AND VENT SYSTEMS.** In lieu of providing individual vents, fixtures may be vented in accordance with pars. (a) to (c).

(a) *Stacks.* 1. A drain stack may serve as a combination drain and vent system for identical fixtures in accordance with subd. 1. a. to e.

a. The drain stack shall not serve more than 3 identical fixtures. Each fixture shall be located on a separate floor level.

b. The drain stack shall be limited to serving kitchen sinks with or without food waste grinders or dishwasher connections within dwelling units, drinking fountains and lavatories.

c. The drain stack shall not be offset horizontally above the lowest fixture drain connection.

d. The developed length of any fixture drain from the trap weir to the drain stack shall not exceed the limits specified in Table 82.31-1.

e. The drain stack and its attendant stack vent shall be sized in accordance with Table 82.31-5.

Note: See Appendix for further explanatory material.

2. Except as provided in subds. (12) and (17), vent piping serving a wall-outlet fixture may not offset horizontally less than 36 inches above the floor, but in no case lower than the elevation of the highest flood level rim of any fixture served by the vent.

3. Vent piping may not connect to a branch vent less than 38 inches above the floor, but in no case lower than 2 inches above the elevation of the highest flood level rim of any fixture served by the vent.

Note: See Appendix for further explanatory material.

(16) **VENT TERMINALS.** All vents and vent systems shall terminate in the open air in accordance with this subsection.

Table 82.31-4

SIZE AND LENGTH OF VENTS FOR SANITARY SUMPS

Discharge Capacity of Ejector (gpm)	Maximum Developed Length of Vent ^a (feet)				
	Diameter of Vent (inches)				
	1 1/4	1 1/2	2	3	4
10	NL ^b				
20	270	NL			
40	72	160	NL		
60	31	75	270	NL	
80	16	41	150	NL	
100	10	25	97	NL	
150	NP ^c	10	44	370	NL
200		NP	20	210	NL
250		NP	10	132	NL
300		NP	10	88	380
400			NP	44	210
500			NP	24	130

a: The developed length of the vent is measured along the pipe from the connection to the sump, to the point where it connects to a vent pipe of a larger diameter.

b: NL means No Limit.

c: NP means Not Permitted.

Table 82.31-5

Fixtures Connected	Size of Stack (inches)
Drinking Fountains	1 1/2
Lavatories	2
Kitchen Sinks	3

f. For the purpose of this subdivision a vent stack shall not be required to serve this type of combination drain and vent arrangement.

2. A drain stack may serve as a combination drain and vent system for a kitchen sink and a laundry tray in accordance with subd. 2. a. to d.

a. One kitchen sink within a dwelling unit, with or without a food waste grinder or dishwasher connection shall connect to the drain stack above the laundry tray. No other fixtures may connect to the drain stack.

b. The drain stack shall be at least 2 inches in diameter below the kitchen sink connection and it shall be at least 4 inches in diameter below the laundry tray connection.

c. In lieu of the minimum sizes as required in subd. 2. b., the entire stack below the kitchen sink connection may be 3 inches in diameter.

d. The drain stack shall not offset horizontally above the fixture drain connection for the laundry tray.

(b) *Building drains.* A building drain or a building subdrain may serve as a combination drain and vent system for floor drains and floor outlet fixtures in accordance with subds. 1. to 6.

1. A vent stack or a drain stack at least 2 inches in diameter shall be connected upstream of any building drain branch or building subdrain branch.

2. No more than 2 water closets may connect to the building drain or building subdrain by means of building drain branches or building subdrain branches.

3. a. That portion of the building drain or building subdrain between the connection of the building drain branch or building subdrain branch and the vent stack or drain stack required in subd. 1. shall be at least one pipe size larger than the minimum size permitted in Table 82.30-3 based on the total drainage fixture unit load.

b. The vent stack or drain stack required in subd. 1. shall be at least one-half the diameter of that portion of the building drain or building subdrain which is vented by the stack, but may not be less than 2 inches in diameter.

c. A stack vent serving a drain stack required in subd. 1. shall be at least one half the diameter of that portion of the building drain or building subdrain which is vented by the stack, but may not be less than 2 inches in diameter.

4. The trap of a floor drain or a floor outlet fixture, except a water closet, connected to a building drain branch or building subdrain branch shall be at least 3 inches in diameter.

5. A building drain branch or building subdrain branch may not connect to a building drain or building subdrain downstream from the base fitting of a drain stack 2 inches or larger in diameter within the distance equal to 20 pipe diameters of the building drain or building subdrain.

6. The pitch and the developed length of the building drain branch or building subdrain branch may not exceed the limits specified in Table 82.31-1.

Note: See Appendix for further explanatory material.

(c) *Laboratory sink venting.* A horizontal drain may serve as a combination drain and vent system for island laboratory sinks in accordance with subds. 1. to 7.

1. A vent stack or a drain stack at least 2 inches in diameter shall be connected upstream of any fixture drain vented by the combination drain and vent system.

2. a. That portion of the horizontal drain between the connection of fixture drain and the vent stack or drain stack required in subd. 1. shall be at least one pipe size larger than the minimum size permitted in Table 82.30-2 based on total drainage fixture unit load.

b. The vent stack or drain stack required in subd. 1. shall be at least one-half the diameter of that portion of the horizontal drain which is vented by the stack, but may not be less than 2 inches in diameter.

c. A stack vent serving a drain stack required in subd. 1. shall be at least one half the diameter of that portion of the horizontal

drain which is vented by the stack, but may not be less than 2 inches in diameter.

3. All fixture drains vented by the horizontal drain shall be at least 3 inches in diameter.

4. Fixture drains to be vented by the horizontal drain shall connect individually to the horizontal drain.

5. An individual vent or common vent shall be extended as high as possible under the sink enclosure and then returned vertically downward and connected to the horizontal drain. A cleanout shall be provided on the vent piping.

6. In lieu of connecting the vent to the horizontal drain which forms the combination drain and vent system, the vent may connect to a horizontal fixture drain vented by the combination drain and vent system. The pitch and developed length of the horizontal fixture drain shall not exceed the limits specified in Table 82.31-1.

7. Fixture drains to be vented by the horizontal drain shall not connect to a horizontal drain downstream from the base fitting of a drain stack 2 inches or larger in diameter within the distance equal to 20 pipe diameters of the horizontal drain serving the stack.

Note: See Appendix for further explanatory material.

(18) **PROHIBITED USES.** A vent or vent system shall not be used for purposes other than the venting of the plumbing system.

(a) *Boiler blowoff basin vents.* Vent piping from boiler blowoff basins shall not be connected to a vent or vent system serving a sanitary drain system, storm drain system or chemical waste system.

(b) *Chemical waste vents.* Vent piping for chemical waste systems shall not be connected to a vent system serving a sanitary drain system or storm drain system.

(c) *Steam vents.* Vents serving steam operated sterilizers, cleansing or degreasing equipment, pressing machines or any other apparatus which normally discharges steam into the vent shall not be connected to a vent or vent system serving a sanitary drain system, storm drain system or chemical waste system.

History: Cr. Register, February, 1985, No. 350, eff. 3-1-85; am. (11) (a), (17) (b) 3. b. and (c) 2. b., r. and recr. (11) (b), r. (13) (a) 2., cr. (17) (b) 3. c. and (c) 2. c., Register, May, 1988, No. 389, eff. 6-1-88; reprinted to correct (17) (c) 4., Register, February, 1991, No. 422; cr. (4) (b) 4. and (17) (a) l. f., r. and recr. (5) (c) l. c. and (17) (c) 4., am. (5) (c) 2. c., (10) (intro.), (b) l., (11) (b), (17) (a) l. e. and (17) (b), Register, August, 1991, No. 428, eff. 9-1-91; am. (6) (c), (7) (b), (10) (intro.), (a), (b) l., (c), (13) (a) l. c., (c) (intro.), l. and 4., r. (16) (h), Register, February, 1994, No. 458, eff. 3-1-94.

Comm 82.32 Traps and direct fixture connections.

(1) **SCOPE.** The provisions of this section set forth the requirements for the types and installation of traps and direct fixture connections.

(2) **MATERIALS.** All traps and fixture connections shall be of approved materials in accordance with ch. Comm 84.

(3) **GENERAL.** Each plumbing fixture, each compartment of a plumbing fixture and each floor drain shall be separately trapped by a water seal trap, except as provided in par. (a). A fixture shall not be double trapped.

(a) *Trap exceptions.* The plumbing fixtures listed in subds. 1. to 3. shall not be required to be separately trapped:

1. Fixtures having integral traps;

2. Compartments of a combination plumbing fixture installed on one trap, provided:

a. No compartment is more than 6 inches deeper than any other;

b. The distance between the compartments' waste outlets farthest apart does not exceed 30 inches; and

c. No compartment waste outlet is equipped with a food waste grinder.

3. Storm drains as provided in s. Comm 82.36 (14) (b).

(b) *Trap seals.* Each trap shall provide a liquid seal depth of not less than 2 inches and not more than 4 inches, except as otherwise specified in this chapter.

(c) *Loss of trap seal.* A trap seal primer valve may be installed on a trap subject to high rates of evaporation.

1. A trap seal primer valve shall be installed on a receptor of indirect wastes not subject to year round use.

2. Trap seal primer valves shall conform to ASSE 1018.

Note: A list of referenced standards is contained in ch. Comm 84.

(d) *Design.* Traps shall be self-scouring and shall not have interior partitions, except where such traps are integral with the fixture. Uniform diameter P-traps shall be considered self-scouring.

(e) *Size.* Traps shall be of diameters not less than those specified in Table 82.30-1 of s. Comm 82.30.

(f) *Prohibited traps.* The installation of the types of traps listed in subds. 1. to 6. shall be prohibited:

1. Bell traps;

2. Drum traps; except where specifically approved by the department;

3. S-traps which are not integral parts of fixtures;

4. Separate fixture traps which depend on interior partitions for the trap seal;

5. Traps which depend upon moving parts to maintain the trap seal; and

6. Traps which in case of defect would allow the passage of sewer air.

(4) *INSTALLATION.* (a) *Setting of traps.* All traps shall be rigidly supported and set true with respect to the water level and so located as to protect the water seals, and shall be protected from freezing and evaporation.

(b) *Distance from fixture drain outlets.* 1. Vertical distance. Except as provided in subd. 1. a. to c., the vertical distance between the top of the fixture drain outlet and the horizontal center line of the trap outlet shall not exceed 15 inches.

a. The vertical distance between the top of the strainer of a floor drain or the opening of a standpipe receptor and the horizontal center line of the trap outlet shall not exceed 36 inches.

b. The vertical distance between the top of the fixture drain outlet of a pedestal drinking fountain and the horizontal center line of the trap outlet shall not exceed 60 inches.

c. The vertical distance between the water level in the bowl of a floor outlet water closet and the center line of the horizontal portion of the fixture drain shall not exceed 36 inches.

2. Horizontal distance. The horizontal distance between the vertical center line of a fixture drain outlet and the vertical center line of the trap inlet shall not exceed 15 inches, except the horizontal distance for a pedestal drinking fountain shall not exceed 24 inches.

Note: See Appendix for further explanatory material.

(5) *DIRECT FIXTURE DRAIN CONNECTION.* Except as provided in s. Comm 82.33, all plumbing fixtures and appliances discharging wastes shall connect directly to a drain system.

(a) *Floor drains.* 1. Floor drains shall be so located as to be accessible for cleaning purposes.

2. A floor drain receiving the wash from garbage cans shall be at least 3 inches in diameter.

(b) *Kitchen sinks.* Horizontal drain piping serving a kitchen sink trap shall not connect to vertical drain piping by means of a double sanitary tee.

(c) *Water closets.* A water closet shall discharge through a drain pipe or fitting with a minimum diameter of 3 inches.

1. A floor mounted wall outlet water closet shall connect to a 4 inch or 4 × 3 inch closet collar fitting or to a horizontal or vertical carrier type fitting.

2. A floor outlet water closet shall connect to a 4 inch or 4 × 3 inch closet collar fitting. A 4 × 3 inch closet bend fitting may be installed where a 4 inch closet collar fitting is used.

3. A wall mounted wall outlet water closet shall connect to a horizontal or vertical carrier type fitting.

4. Two water closets discharging to a vertical drain from opposite sides by means of the same fitting shall be installed in accordance with subd. 4. a. and b.

a. Where the vertical drain is 3 inches in diameter, the fitting for floor outlet water closets shall be a 3 inch double wye pattern fitting.

b. Where the water closets are wall outlet types the fitting shall be a double wye pattern fitting or a carrier-type fitting.

(d) *Blowout-type fixtures.* Blowout-type plumbing fixtures shall be installed in accordance with the approval of the department.

History: Cr. Register, February, 1985, No. 350, eff. 3-1-85; am. (4) (a), cr. (5) (intro.) and (d), Register, May, 1988, No. 389, eff. 6-1-88.

Comm 82.33 Indirect and local waste piping.

(1) *SCOPE.* (a) The provisions of this section set forth the requirements for the installation of indirect waste piping and local waste piping.

(b) Indirect waste piping and local waste piping draining the fixtures, appliances and devices having a public health concern, including but not limited to those listed in Table 82.33-1, shall be considered as plumbing and shall comply with the provisions of this section.

Table 82.33-1

TYPES OF FIXTURES, APPLIANCES AND DEVICES OF A PUBLIC HEALTH CONCERN

Refrigerated food storage rooms and compartments	Coffee makers and urns
Refrigerated food display cases	Food processing equipment
Ice compartments	Baptismal fountains
Vending machines	Clothes washers and extractors
Steam tables and kettles	Dishwashers
Food preparation sinks	Stills
Potato peelers	Sterilizers
Egg boilers	Bar and soda fountains

Boiler blowoff basin outlet drains

(2) *MATERIALS.* Indirect waste piping more than 30 inches in length and all local waste piping shall be of approved materials in accordance with ch. Comm 84.

(3) *SIZE.* Except as provided in pars. (a) and (b), indirect waste piping more than 30 inches in length and all local waste piping shall be sized in accordance with s. Comm 82.30.

(a) Indirect or local waste piping not exceeding 20 feet in length for refrigerated food display cases may not be less than one inch in diameter.

(b) Indirect waste piping, attached to an appliance, appurtenance or equipment through which pressurized waste is discharged, shall be sized in accordance with specifications of the manufacturer of the appliance, appurtenance or equipment.

(4) *INSTALLATION.* Indirect waste piping and local waste piping shall be so installed as to permit access for flushing and cleaning.

(5) *TRAPS.* (a) *Indirect waste piping.* 1. Gravity flow indirect waste piping more than 30 inches in length shall be provided with

a trap in accordance with s. Comm 82.32 (4), except indirect waste piping draining a sterilizer shall not be trapped.

2. All indirect waste piping draining a refrigerated compartment shall be provided with a trap in accordance with s. Comm 82.32 (4).

(b) *Local waste piping.* Local waste piping handling sanitary wastes and more than 30 inches in length shall be provided with a trap in accordance with s. Comm 82.32 (4).

(6) **MAXIMUM LENGTH.** Indirect waste piping and local waste piping handling sanitary wastes shall not exceed 30 feet in length horizontally nor 15 feet in length vertically.

Note: See Appendix for further explanatory material.

(7) **AIR-GAPS AND AIR-BREAKS.** All indirect waste piping and all local waste piping shall discharge by means of an air-gap or air-break into a receptor.

(a) *Air-gap installation.* 1. The distance of an air-gap between indirect waste piping one inch or less in diameter and the receptor shall be at least twice the diameter of the indirect waste piping.

2. The distance of an air-gap between indirect waste piping larger than one inch in diameter and the receptor shall be not less than 2 inches.

(b) *Air-break installation.* The air-break between indirect waste piping or local waste piping and the receptor shall be accomplished by extending the indirect waste piping or local waste piping below the flood level rim of the receptor.

Note: See Appendix for further explanatory material.

(8) **RECEPTORS.** A receptor receiving the discharge from indirect waste piping or local waste piping shall be of a shape and capacity as to prevent splashing or flooding. Receptors shall be installed in accordance with this subsection and shall be accessible.

(a) *Waste sinks and standpipes.* 1. A waste sink or a standpipe serving as a receptor shall have its rim at least one inch above the floor.

2. A waste sink or a standpipe serving as a receptor shall be individually trapped in accordance with s. Comm 82.32.

(b) *Floor sinks.* A floor sink serving as a receptor shall be equipped with a removable metal basket over which the indirect waste piping or local waste piping is to discharge, or the floor sink shall be equipped with a dome strainer. Indirect waste piping or local waste piping shall not discharge through a traffic grate, but shall terminate over an ungrated portion of the floor sink.

(c) *Local waste piping.* 1. Local waste piping serving as a receptor shall discharge to a waste sink, standpipe or floor sink, except as provided in subd. 2.

2. Local waste piping serving as a receptor for a water heater safety relief valve may discharge to a floor drain.

3. Local waste piping may not receive the discharge from another local waste pipe.

(d) *Prohibited receptors.* Except as provided in subs. 1. and 2., a plumbing fixture which is used for domestic or culinary purposes shall not be used as a receptor for indirect waste piping or local waste piping.

1. The indirect waste piping of a portable dishwasher or point-of-use water treatment device may discharge into a kitchen sink of a dwelling unit.

2. The indirect waste piping of an automatic clothes washer or water treatment device may discharge into a laundry tray.

Note: See Appendix for further explanatory material.

(9) **INDIRECT WASTE PIPING REQUIRED.** (a) *Boilers, pressure tanks and relief valves.* Boilers, pressure tanks, relief valves and similar equipment discharging to a drain system shall be by means of an air-gap.

1. Steam pipes shall not connect or discharge to any part of a plumbing system.

2. Waste water more than 160° F. in temperature shall not discharge into any part of a plumbing system.

(b) *Clear water wastes.* 1. Clear water wastes, except those from a drinking fountain, discharging to a drain system shall be by means of an air-gap.

2. The clear water wastes from a drinking fountain discharging to a drain system shall be by means of a direct connection.

(c) *Clothes washers.* 1. Residential types. Residential-type clothes washers shall discharge into the sanitary drain system by means of an air-break.

a. A standpipe receptor may not extend more than 36 inches nor less than 18 inches above the top of the trap weir.

b. The top of a standpipe receptor shall terminate at least 32 inches but not more than 42 inches above the floor on which the washer is located.

2. Self-service laundries. Pumped-discharge automatic clothes washing equipment in laundrettes, laundromats and self-service laundry establishments shall have the wastes discharge to a drain system by means of standpipes. The standpipes shall be installed in accordance with subd. 1.

a. The maximum number of washers which may be connected to a trap shall be in accordance with Table 82.33-2.

b. Washer wastes shall not be discharged to gutters, troughs, local waste piping, indirect waste manifold or other similar connections.

3. Commercial. Gravity discharge-type clothes washing equipment shall discharge by means of an air-break or by other approved methods into a floor receptor, trench or trough.

a. The receptor shall be sized to hold one full simultaneous discharge load from every machine draining into the receptor.

b. The size of the receptor drain shall be determined by the manufacturer's discharge flow rate and the frequency of discharge.

Note: See Appendix for further explanatory material.

c. All wastes from the washers shall flow through a Commercial laundry interceptor as specified in s. Comm 82.34.

Table 82.33-2

WASHER CONNECTIONS

Trap Diameter	Maximum Number of Washers
2 inches	2 machines
3 inches	3 machines
4 inches	4 machines

(d) *Dishwashing machines.* 1. Residential-type. A residential-type dishwashing machine shall discharge to the sanitary drain system by means of a fixed air-gap or air-break located above the high water level of the dishwashing machine. The indirect waste piping or hose from the dishwashing machine shall not exceed a developed length of 10 feet. The indirect waste piping shall be installed in accordance with one of the methods specified in subd. 1. a. and b.

a. An air-gap or air-break may be located below a countertop. Where the air-gap or air-break is located below a countertop, the indirect waste piping from the dishwashing machine shall discharge into a standpipe. The standpipe shall be at least 1½ inches in diameter and shall extend at least 12 inches above the trap inlet.

b. An air-gap may be located above a countertop. Where the air-gap is located above a countertop, the indirect waste piping from a dishwashing machine shall discharge into either a standpipe or local waste piping. The standpipe shall be at least 1½ inches in diameter and shall extend at least 12 inches above the trap inlet. The local waste piping shall connect to the fixture drain of a kitchen sink above the trap inlet. Where a hose is used for local waste piping, the developed length shall not exceed 18 inches.

2. Commercial. Commercial dishwashing machines shall discharge into a sanitary drain system by means of an air-gap or

air-break into a trapped and vented receptor. The indirect waste piping may not be more than 30 inches in length.

3. Prohibited installations. No dishwashing machine may discharge into or through a food waste grinder.

Note: See Appendix for further explanatory material.

(e) *Drips and drain outlets.* Appliances, devices and apparatus not defined as plumbing fixtures which have drip or drain outlets shall be drained through indirect waste piping into an open receptor by means of an approved air-gap or air-break.

(f) *Elevator pit subsoil and floor drains.* A subsoil or floor drain installed in an elevator pit shall discharge through indirect waste piping for disposal in accordance with s. Comm 82.36 (3).

1. A sump pump shall not be located in an elevator pit.

2. The sump containing the pump for an elevator pit shall have a submerged inlet constructed to maintain a minimum 6 inch trap seal.

Note: See Appendix for further explanatory material.

(g) *Food handling establishments.* Plumbing fixtures, devices and appurtenances installed in food handling establishments engaged in the storage, preparation, selling, serving or processing of food shall be installed in accordance with this paragraph.

1. Bar and soda fountain sinks. Where a bar or soda fountain sink is so located that the trap for the sink cannot be vented as specified in s. Comm 82.31, the sink drain shall discharge to the sanitary drain system through indirect waste piping.

a. Where the indirect waste piping is not trapped, the wastes shall be discharged by means of an air-gap.

b. Where the indirect waste piping is trapped, the wastes shall be discharged by means of an air-gap or air-break.

2. Beer taps, coffee makers, glass fillers and soda dispensers. The drip pan from a beer tap, coffee maker, glass filler, soda dispenser or similar equipment shall discharge to the sanitary drain system through indirect waste piping by means of an air-break or air-gap.

3. Novelty boxes, ice compartments and ice cream dipper wells. Novelty boxes, ice compartments and ice cream dipper wells shall discharge to the sanitary drain system through indirect waste piping by means of an air-gap.

a. The indirect waste piping shall not exceed 30 inches in length.

b. The indirect waste piping draining a novelty box or ice compartment may not discharge or connect to the indirect waste piping or local waste piping of any other fixture, appliance or device other than a novelty box or ice compartment.

4. Refrigerated food storage rooms, compartments and display cases. Drains serving refrigerated food storage rooms, compartments or display cases shall discharge to the sanitary drain system through indirect waste piping. The indirect waste piping shall drain by gravity to a receptor by means of an air-gap or air-break. Where an air-break is installed, the flood level rim of the receptor shall be at least 2 inches below the top of the fixture strainer or drain opening in the refrigerated room, compartment or display case.

5. Enclosed food processing equipment. Coffee urns, egg boilers, potato peelers, steam kettles, steam tables, vending machines and similar types of enclosed food processing equipment shall be discharged to the sanitary drain system through indirect waste piping by means of an air-gap.

6. Preparation sinks. Open culinary sinks for thawing or washing food shall discharge to the sanitary drain system through indirect waste piping by means of an air-gap. The indirect waste piping may not exceed a length of 30 inches.

Note: See Appendix for further explanatory material.

(h) *Sterilizers.* Appliances, devices or apparatus, such as stills, sterilizers and similar equipment requiring waste connections and used for sterile materials, shall discharge through indirect waste piping to the sanitary drain system by means of an air-gap.

Note: See s. Comm 82.50 regarding sterilizer wastes.

(i) *Swimming pools.* 1. Waste water from swimming or wading pools, including pool drainage and backwash from sand filters, shall be discharged to the storm sewer through indirect waste piping.

2. Waste water from floor drains which serve interior walks around pools and backwash from diatomaceous earth filters shall be discharged to the sanitary sewer through indirect waste piping.

3. Where a recirculation pump is used to discharge waste pool water to the drain system, the pump shall discharge to the drain system through indirect waste piping.

4. All indirect waste piping serving pools and pool areas shall discharge by means of an air-gap.

5. The requirements for sewer connections as specified in ch. ILHR 90 shall apply to all swimming pools.

(j) *Vacuum systems—central units.* Central vacuum units shall discharge by means of an air-gap or air break.

(10) **WATER TREATMENT DEVICES.** The waste discharge of a water treatment device to the drain system shall be protected in accordance with s. Comm 82.41 with respect to cross connection control.

Note: For appliances, devices and equipment not included in this section or other sections contact the department for information and proposed installation review.

History: Cr. Register, February, 1985, No. 350, eff. 3-1-85; r. and rec. Table 82.33-1 and (9) (g) 5., cr. (8) (c) 3., (9) (g) 6. and (k), Register, May, 1988, No. 389, eff. 6-1-88; r. and rec., (3), am. (9) (c) 1. a., (d) 2. and (g) 4., Register, August, 1991, No. 428, eff. 9-1-91; am. (8) (d) 1., 2. and (9) (g) 3. b., r. (9) (k), cr. (10), Register, February, 1994, No. 458, eff. 3-1-94; correction in (9) (i) 5., made under s. 13.93 (2m) (b) 7., Stats., Register, February, 1994, No. 458.

Comm 82.34 Interceptors and catch basins for special and industrial wastes. (1) **SCOPE.** The provisions of this section set forth the requirements for design and installation of interceptors and catch basins to handle special and industrial wastes.

(2) **MATERIALS.** All piping, interceptors and catch basins for special and industrial wastes shall be of approved materials in accordance with ch. Comm 84.

(3) **GENERAL.** Any deleterious waste material which is discharged into a plumbing system shall be directed to an interceptor, catch basin or other approved device. The interceptor, catch basin or approved device shall be capable of separating the deleterious waste material from the normal sewage and retaining the deleterious waste material to facilitate its periodic removal or treatment or both.

(a) *Deleterious waste materials.* For the purpose of this subsection, deleterious waste materials include any waste material, other than that from dwelling units, which may:

1. Congeal, coagulate or accumulate in drains and sewers, thereby, creating stoppages or retarding the discharge flow;

2. Retard or interfere with municipal sewage treatment processes;

3. Pass through a treatment process and pollute the watercourse receiving the treatment effluent;

4. Create explosive, flammable, noxious, toxic or other hazardous mixtures of materials; or

5. Damage, destroy or deteriorate sewers or piping materials or structures.

Note: See ch. ILHR 10 as to flammable and combustible liquids.

(b) *Private disposal systems.* The special or industrial wastes from any plumbing system which are not discharged into a public sewer system shall be treated or disposed in compliance with the rules of the state agency having jurisdiction. The treatment or disposal system shall be installed so as not to endanger any water supply which is or may be used for drinking, culinary or bathing purposes, or which may create a nuisance, unsanitary conditions or water pollution.

(c) *Velocity control.* Interceptors, catch basins and other similar devices shall be designed, sized and installed so that flow rates shall be developed and maintained in a manner that solid and

floating materials of a harmful, hazardous or deleterious nature will be collected in the interceptor for disposal.

(d) *Maintenance.* All devices installed for the purpose of intercepting, separating, collecting, or treating harmful, hazardous or deleterious materials in liquid or liquid-borne wastes shall be operated and cleaned of intercepted or collected materials or of any residual from treatment at such intervals which may be required to prevent their passage through the interceptor.

(e) *Service reassembly.* Any fixed orifice, vent or trap of an interceptor, catch basin or other similar device shall remain intact and shall not be removed or tampered with except for cleaning purposes. After service, all parts of the interceptor, collector or treatment device, such as baffles, weirs, orifice plates, channels, vents, traps, tops, and fastening bolts or screws shall be replaced in proper working position.

(f) *Location.* 1. Interceptors, catch basins and other similar devices shall be accessible for service, maintenance, repair and inspection.

a. No interceptor, catch basin or similar device may be surrounded or covered as to render it inaccessible for service or inspection.

b. No interceptor, catch basin or similar device may have its top located more than 6 feet above the surrounding floor.

c. Enough space shall be provided to enable the removal of any interior parts of the interceptor, catch basin or similar device.

d. At least 18 inches of clear space shall be provided above the top of the interceptor, catch basin or similar device.

2. An interceptor, catch basin, or similar device shall not be located within 25 feet of a water well.

(g) *Construction.* 1. Base. Site-constructed catch basins and interceptors shall have at least a 6 inch thick air-entrained concrete base with a minimum estimated compressive strength at 28 days of 3000 psi or an approved precast base.

2. Sides and tops. The sides and tops of poured-in-place concrete catch basins and interceptors shall be at least 6 inches thick air-entrained concrete with a minimum estimated compressive strength at 28 days of 3000 psi.

3. Prefabricated catch basins and interceptors shall be approved by the department prior to installation.

(h) *Disposition of retained materials.* Deleterious waste materials retained by an interceptor, catch basin or similar device shall not be introduced into any drain, sewer or natural body of water without approval of the state agency having jurisdiction.

(4) **GARAGE CATCH BASINS AND INTERCEPTORS.** (a) *Public buildings.* Except as provided in subd. 1., the discharge waste from floor areas of public buildings on which self-propelled land, air or water vehicles can be driven, stored or serviced or on which engines or motorized equipment is serviced or stored shall be discharged through a garage catch basin or through a sand interceptor and an oil interceptor.

1. Exception. The discharge wastes of those floor areas where only vehicles such as forklift trucks are utilized shall not be required to be discharged through a garage catch basin or interceptor.

2. Design of garage catch basins. a. The base for a site-constructed garage catch basin shall extend at least 4 inches beyond the outside of the catch basin wall.

b. The catch basin shall have a minimum inside diameter or horizontal dimension of 36 inches and a minimum inside depth of 48 inches.

c. The outlet for a catch basin shall be at least 4 inches in diameter. The outlet shall be submerged to form a trap with a water seal of at least 6 inches. The bottom of the trap's water seal shall be at least 18 inches above the bottom of the catch basin.

d. The drain from the catch basin shall be provided with a cleanout extended to grade. The cleanout shall be sized in accordance with s. Comm 82.35.

e. The waterline in the catch basin shall be at least 2 inches below horizontal drains discharging into the catch basin.

f. The catch basin shall be provided with an open grate cover of at least 24 inches in diameter.

g. Where the outlet for a catch basin is installed so that the waterline is more than 12 inches below the floor level, a local vent pipe of at least 4 inches in diameter shall be provided. The local vent pipe shall connect to the catch basin at least 2 inches above the waterline and shall terminate in accordance with s. Comm 82.31 (16) or to the outside of the building with a return bend fitting or vent cap terminating not less than one foot above grade.

h. Not more than 8 trapped floor drains of at least 3 inches in diameter may connect individually to the lowest horizontal portion of a local vent where that lowest horizontal portion of the local vent does not exceed a length of 100 feet. The change in elevation of the fixture drain between the trap weir of the floor drain and the local vent shall not exceed the diameter of the fixture drain pipe.

i. Trapped floor drains, at least 3 inches in diameter, may connect to a garage catch basin. The change in elevation of the fixture drain between the trap weir of the floor drain and the catch basin shall not exceed the diameter of the fixture drain pipe.

3. Trench drain. a. Each open grate trench which is to serve floor areas subject to vehicular traffic shall discharge to a catch basin by means of a fixture drain of at least 4 inches in diameter.

b. The fixture drain from a trench drain shall extend at least 6 inches below the waterline of the catch basin.

c. The developed length of the fixture drain between the trench drain and the catch basin shall not exceed the distance equal to 24 times the diameter of the fixture drain.

Note: See Appendix for further explanatory material.

(b) *Garages for one- and 2-family dwellings.* 1. Floor drains serving garages for one- and 2-family dwellings shall be provided with a solid bottom sediment basket.

Note: See Appendix for further explanatory material.

2. Catch basins serving garages for one- and 2-family dwellings shall be in accordance with par. (a).

(c) *Grates for garage catch basins, floor drains and trenches.* A garage catch basin, floor drain and trench drain shall be provided with an approved, removable cast iron or steel grate of a thickness and strength for the anticipated loads. The grate shall have an available inlet area equal to at least the outlet drain for the catch basin, floor drain or trench drain.

(5) **GREASE INTERCEPTORS.** All plumbing installations for occupancies, other than dwelling units, where grease, fats, oils or similar waste products of cooking or food are introduced into the drain system shall be provided with interceptors in accordance with this subsection. All drains and drain piping carrying oil, grease or fats shall be directed through one or more interceptors as specified in par. (a).

(a) *General.* 1. Public sewers. All new, altered or remodeled plumbing systems which discharge to public sewers shall be provided with one or more exterior grease interceptors or one or more interior grease interceptors.

a. Where one or more exterior grease interceptors are provided all and only kitchen wastes shall be discharged to an exterior interceptor.

b. Where one or more interior grease interceptors are provided the wastes from a food waste grinder or a sanitizing compartment of a sink, or both, may bypass the interceptor or interceptors.

2. Private sewage systems. All new, altered or remodeled plumbing systems which discharge to private sewage systems shall be provided with exterior grease interceptors.

a. Except as provided in subd. 2. b., only kitchen and food wastes shall be discharged to an exterior grease interceptor.

b. Where approved by the department combined kitchen wastes and toilet wastes may be discharged directly to a septic

tank or tanks which conform to par. (b). The required capacity of a grease interceptor shall be added to the required septic tank capacity as specified in ch. Comm 83.

3. Existing installations. The department may require the installation of either interior or exterior grease interceptors for existing plumbing installations where the waterway of a drain system, sewer system or private sewage system is reduced or filled due to congealed grease.

(b) *Exterior grease interceptors.* Exterior grease interceptors shall receive the entire waste discharge from kitchens or food processing areas. All exterior interceptors shall be designed and constructed in accordance with this paragraph, so as to constitute an individual structure.

1. Design. a. The liquid depth of the interceptor shall not be less than 42 inches nor more than an average of 72 inches.

b. A rectangular interceptor tank shall have a minimum width of 36 inches and a minimum length of 72 inches. The longest dimension of the tank shall be parallel to the direction of waste flow.

c. A horizontal-cylindrical interceptor tank shall have a minimum inside diameter of 52 inches and a minimum length of 72 inches. The longest dimension of the tank shall be parallel to the direction of waste flow.

d. Vertical-cylindrical interceptor tanks shall have a minimum inside diameter of 72 inches.

e. Each prefabricated interceptor tank shall be clearly marked to indicate liquid capacity and the name and address or registered trademark of the manufacturer. The markings shall be impressed into or embossed onto the outside wall of the tank immediately above the outlet opening. Each site-constructed concrete tank shall be clearly marked at the outlet opening to indicate the liquid capacity. The marking shall be impressed into or embossed onto the outside wall of the tank immediately above the outlet opening.

f. The inlet and outlet openings of interceptor tanks or tank compartments shall be provided with, open-end sanitary tee fittings or baffles, so designed and constructed as to distribute the flow and retain the grease in the tank or tank compartments. The sanitary tee fittings or baffles shall extend at least 6 inches above the liquid level. At least 2 inches of clear space shall be provided above the top of the sanitary tee fittings or baffles. The sanitary tee fitting or baffle at the inlet opening shall extend below the liquid level of the tank a distance equal to $\frac{1}{3}$ of the total liquid depth. The sanitary tee fitting or baffle at the outlet opening shall extend below the liquid level of the tank a distance equal to $\frac{2}{3}$ of the total liquid depth. The waterline in the interceptor shall be at least 2 inches below the horizontal drain discharging to the interceptor.

g. Each compartment of an interceptor tank shall be provided with at least one manhole opening located over either the inlet or outlet opening. Additional manhole openings shall be provided such that no interior compartment wall of a tank is more than 4 feet from the edge of the manhole opening. The distance between manhole openings serving the same compartment shall not exceed 8 feet. Manhole openings shall be not less than 24 inches in the least dimension. Manholes shall terminate at or above ground surface and be of approved materials. Steel tanks shall have a minimum 2 inch collar for the manhole extensions permanently welded to the tank. The manhole extension on fiberglass tanks shall be of the same material as the tank and an integral part of the tank. The collar shall have a minimum height of 2 inches.

h. Manhole risers for interceptor tanks shall be provided with a substantial, fitted, watertight cover of concrete, steel, cast iron or other approved material. Manhole covers shall terminate at or above grade and shall have an approved locking device.

i. A minimum 4 x 6 inch permanent label shall be affixed to the manhole cover, identifying the interceptor tank with the words GREASE INTERCEPTOR. Where the tank acts as the septic tank and grease interceptor the label shall identify it as such. The wording used on the warning label shall be approved by the department, as part of the materials approval for the tank under ch. Comm 84.

j. An inlet or outlet opening which does not have a manhole opening as specified in subd. 1. g. shall be provided with an airtight inspection opening located over the inlet or outlet. The inspection opening shall be at least 4 inches in diameter. The inspection opening shall terminate at or above grade.

Note: See Appendix for further explanatory material.

2. Capacity and sizing. The minimum liquid capacity of a grease interceptor shall be determined in accordance with the provisions of this subdivision, except no grease interceptor may have a capacity of less than 1000 gallons if the interceptor is to discharge to a private sewage system or less than 750 gallons if the interceptor is to discharge to a municipal sewer system and treatment facility.

a. The minimum capacity of a grease interceptor serving a restaurant with seating shall be equal to C, where

$$C = S \times H \times A$$

where, S = Number of seats, with each drive-in car service space counting as 3 seats and each drive-up service window counting as 60 seats.

H = Hours per day that meals are served, at least 6 hours but not more than 12 hours.

A = Appliance factor:

0.75 for a kitchen with no dishwashing machine and no food waste grinder.

1.0 for a kitchen with either a dishwashing machine or a food waste grinder.

1.25 for a kitchen with both a dishwashing machine and a food waste grinder.

b. The minimum capacity of a grease interceptor serving a dining hall, hospital, nursing home, school kitchen, church kitchen or a kitchen for carryout or delivery service shall be equal to C, where:

$$C = \frac{M \times G \times H}{2 \times P}$$

where, M = Meals served per day.

G = 3 gallons per meal served.

H = Hours per day that meals are served, at least 6 hours but not more than 12 hours.

P = Meal periods per day; 1, 2 or 3.

c. The minimum capacity of a grease interceptor as determined in subd. 2. a. or b. may be halved for establishments with all paper service, but may not be less than 1000 gallons if the interceptor is to discharge to a private sewage system or less than 750 gallons if the interceptor is to discharge to a municipal sewer system and treatment facility.

3. Installation. a. Grease interceptor tanks may not be located within 5 feet of a building or any portion of the building or swimming pool; 10 feet of a water service; 2 feet of a lot line; 10 feet of a cistern or 25 feet of a reservoir or high water mark of a lake, stream, pond or flowage.

Note: The department of natural resources under ch. NR 113 requires a minimum setback of 25 feet between a grease interceptor and a well.

b. Where a grease interceptor tank is installed in groundwater, the tank shall be adequately anchored.

c. Grease interceptor tanks shall be installed on a bedding of at least 3 inches in depth. The bedding material shall be sand, gravel, granite, limerock or other noncorrosive materials of a size that all will pass through a $\frac{3}{4}$ inch sieve.

d. The backfill material for steel and fiberglass grease interceptor tanks shall be as specified in subd. 3. c. for bedding and shall be tamped into place. The backfill material for concrete

grease interceptor tanks shall be soil material, of a size that will pass through a 4 inch screen and shall be tamped into place.

e. All joints on concrete risers and manhole covers for a grease interceptor shall be tongue and groove or shiplap type and sealed watertight using neat cement, mortar or bituminous compound. All joints on steel risers for a grease interceptor shall be welded or flanged and bolted and be watertight. All steel manhole extensions from a grease interceptor shall be bituminous coated inside and outside. All methods of attaching fiberglass risers for a grease interceptor shall be watertight and approved by the department.

(c) *Interior grease interceptors.* 1. Flow rating. An interior grease interceptor shall be capable of accommodating a flow of at least 15 gallons per minute, but not less than the manufacturer's specifications.

2. Flow rate related to connected capacity. Three-fourths of the total holding capacity in gallons of all fixtures and devices discharging to an interior grease interceptor, shall not exceed the value of the maximum flow rate which the interceptor can accommodate.

3. Grease holding capacity as related to flow rate. The grease holding capacity in pounds shall not be less than double the value of the maximum flow rate which the interceptor can accommodate.

4. Flow controls. Where required by the manufacturer, devices which control the rate of flow through an interior grease intercept shall be installed.

a. The flow control devices shall be accessible for inspection, service and cleaning.

b. Flow controls shall be installed in the drain branch leading to each fixture and shall be so rated that the combined flow from all combinations of discharge will not develop either sufficient static or velocity head so the established flow rate of the interceptor can be exceeded.

Note: See Appendix for further explanatory material.

5. Flow control vents. Orifice type flow controls for an interior grease interceptor shall be vented in accordance with s. Comm 82.31.

6. Prohibited locations and types. No water-cooled grease interceptor may be installed. No grease interceptor may be located where the surrounding temperatures, under operating conditions, are less than 40° F.

(d) *Prohibited treatment.* The introduction of grease or fat emulsifiers into a grease interceptor shall be prohibited.

(6) **AUTOMATIC CAR WASHES.** The wastes of floor drains and drain inlets of automatic car washes shall discharge through an approved car wash interceptor.

(a) *Design.* Except as provided in subs. 1. and 2. and par. (b), car wash interceptors shall be constructed and installed in accordance with sub. (4) (a).

1. The interceptor's outlet shall be submerged to form a trap with a water seal of at least 15 inches.

2. The bottom of the trap's water seal shall be at least 30 inches above the bottom of the interceptor.

(b) *Capacity.* The minimum liquid capacity of the interceptor shall be based on the maximum flow rate of water through the interceptor in gallons per minute.

1. Between the waterline and the bottom of the trap seal of the outlet, the interceptor shall have a capacity value equal to at least 5 times the maximum flow rate.

2. Below the bottom of the trap seal of the outlet, the interceptor shall have a capacity value equal to at least 15 times the maximum flow rate.

Note: See Appendix for further explanatory material.

(c) *Hand-held car washing wands.* The wastes of floor drains and drain inlets serving 2 or more hand-held car washing wands shall discharge through an approved car wash interceptor. The

wastes of one hand-held car washing wand may discharge to a garage catch basin.

(d) *Recirculated water.* Where recirculated water is used for washing, the recirculated water shall be drawn from a separation chamber located upstream from the car wash interceptor.

(7) **COMMERCIAL LAUNDRIES.** Wastes from gravity dump-type clothes washing equipment shall be discharged through an approved laundry interceptor in accordance with this subsection.

(a) *Screening apparatus.* A laundry interceptor shall be equipped with a wire basket or other device which will prevent the passage of solids, 1/2 inch or larger in diameter, string, buttons and other detrimental materials into the drain system.

(b) *Trench type interceptors.* A floor receptor, trench or trough as specified in s. Comm 82.33 (9) (c) 3., may serve as a laundry interceptor, if no oils or quantities of sand are discharged into it.

Note: See Appendix for further explanatory material.

(c) *In-line interceptor.* 1. In-line interceptors shall have a minimum inside diameter or horizontal dimension of 24 inches.

2. An in-line interceptor shall be provided with an air-tight cover.

3. An in-line interceptor shall be provided with a vent.

a. The vent shall extend from above the flow line to a vent terminal in accordance with s. Comm 82.31 (16) or shall be connected to the venting system serving the sanitary drain system.

b. The diameter of the vent shall be at least one-half of the diameter of the interceptor's outlet, but not less than 2 inches.

4. The outlet for an in-line interceptor shall be at least 4 inches in diameter. The outlet shall be submerged to form a trap with a water seal of at least 12 inches. The bottom of the trap's water seal shall be at least 12 inches above the bottom of the interceptor.

5. The waterline in an in-line interceptor shall be at least 2 inches below the bottom of the inlet opening for the interceptor.

(8) **OIL AND FLAMMABLE LIQUIDS.** Oily and flammable wastes discharging to a building sewer shall be discharged through an approved interceptor. Where oily and flammable wastes may overflow by spillage or other circumstances, protective dikes or other similar devices shall be provided to prevent the wastes from entering the drain system.

(a) *Site-constructed interceptors.* 1. Garage catch basins. Site-constructed garage catch basins which serve as an interceptor for oily or flammable wastes shall be constructed and installed in accordance with sub. (4).

2. In-line interceptors. Site-constructed in-line interceptors for oily or flammable wastes shall be constructed and installed in accordance with this subdivision.

a. The base for an in-line interceptor shall extend at least 4 inches beyond the outside of the interceptor.

b. The in-line interceptor shall have a minimum inside diameter or horizontal dimension of 36 inches and a minimum inside depth of 48 inches. The interceptor shall have a minimum liquid capacity of one cubic foot for each 300 square feet of surface area to be drained into the interceptor.

c. The outlet for an in-line interceptor shall be at least 4 inches in diameter. The outlet shall be submerged to form a trap with a water seal of at least 6 inches. The bottom of the trap's water seal shall be at least 18 inches above the bottom of the interceptor.

d. The drain from the in-line interceptor shall be provided with a cleanout extended to grade. The cleanout shall be sized in accordance with s. Comm 82.35.

e. The waterline in the in-line interceptor shall be at least 2 inches below all horizontal drains discharging into the interceptor.

f. Covered in-line interceptors shall be vented in accordance with par. (c).

(b) *Prefabricated oil interceptors and separators.* Prefabricated oil interceptors and separators shall be of a capacity for the anticipated load and shall be installed in accordance with the

manufacturer's written specifications. A manufacturer's rated capacity shall be accepted upon the approval of the department.

1. An oil interceptor or separator shall be provided with an oil storage tank for storing the residue from the interceptor or separator.

2. The oil storage tank shall be provided with a high liquid warning device which will be activated when the liquid level is less than 6 inches below the inlet pipe.

a. The warning device shall be either an audible or illuminated alarm.

b. Illuminated alarms shall be conspicuously mounted.

Note: Electrical installations are to be in accord with ch. Comm 16.

(c) *Venting.* Oil and flammable interceptors and separators shall be so designed to prevent the accumulation of explosive gases.

1. A covered interceptor or separator shall be provided with an individual vent of at least 3 inches in diameter. The vent shall extend from the top of the interceptor or separator or as high as possible, from the side of the interceptor or separator to a point at least 12 feet above grade.

2. The drain pipe to the interceptor or separator shall be provided with a fresh air inlet connected within 2 feet of the inlet of the interceptor or separator. The fresh air inlet shall terminate at least one foot above grade, but not less than 6 feet below the terminating elevation of the vent serving the interceptor or separator. The fresh air inlet shall be at least 3 inches in diameter.

Note: See Appendix for further explanatory material.

(9) **BOTTLING ESTABLISHMENTS.** Wastes containing glass of bottling establishments shall be discharged through an interceptor.

(10) **DAIRY PRODUCT PROCESSING PLANTS.** Dairy wastes from dairy product processing plants shall be discharged through an interceptor.

(11) **MEAT PROCESSING PLANTS AND SLAUGHTERHOUSES.** The wastes from meat processing areas, slaughtering rooms and meat dressing rooms shall be discharged through an approved interceptor to prevent the discharge of feathers, entrails, blood and other materials.

(12) **SAND INTERCEPTORS.** Sand interceptors and other similar interceptors for heavy solids shall be so designed and located as to be accessible for cleaning. The outlet for the interceptor shall be submerged to form a trap with a water seal of at least 12 inches.

(13) **PLASTER AND HEAVY SOLIDS TRAP TYPE INTERCEPTORS.** Plaster sinks shall be provided with plaster and heavy solids trap type interceptors.

(a) The interceptor shall be installed as the fixture trap.

(b) The drain piping between the sink and the interceptor shall not exceed a length of 36 inches.

Note: See Appendix for further explanatory material.

(14) **CHEMICAL WASTE PIPING SYSTEMS.** All chemical wastes having a pH level of less than 5.5 or more than 10.0 shall discharge to a holding tank for proper disposal or to a drain system in accordance with this subsection.

(a) *Chemical dilution and neutralizing basins.* 1. All chemical wastes discharging into a drain system shall be diluted, neutralized or treated to a pH level of 5.5 to 10.0 by passing through an approved dilution or neutralizing basin before discharging to a building sewer.

2. Dilution and neutralizing basins shall have the minimum retention capacities as specified in Table 82.34. For quantities of fixtures exceeding 150 sinks or for special uses or installations, the department shall be consulted as to the minimum capacity of the basin.

3. Where a sufficient supply of diluting water cannot be provided to a dilution or neutralizing basin, the basin shall be filled with marble or limestone chips of not less than one inch nor more than 3 inches in diameter to the level of the basin's outlet.

4. Either the inlet or outlet of a dilution or neutralizing basin shall be submerged to form a trap with a water seal of at least 4 inches.

Table 82.34

MINIMUM CAPACITIES FOR DILUTION AND NEUTRALIZING BASINS

Maximum Number of Sinks	Minimum Retention Capacity in Gallons
1	5
4	15
8	30
16	55
25	100
40	150
60	200
75	250
100	350
150	500

(b) *Vents.* Vents for chemical waste systems shall be sized and installed in accordance with s. Comm 82.31.

1. Dilution and neutralizing basins with submerged inlets shall have a sanitary vent connected to the basin and a chemical waste vent connected to the inlet pipe. The pitch and the developed length of the drain between the submerged basin inlet and the chemical waste vent shall be in accordance with Table 82.31-1.

2. Dilution and neutralizing basins with submerged outlets shall have a chemical waste vent connected to the basin and a sanitary vent connected to the outlet pipe. The pitch and the developed length of the drain between the submerged basin outlet and the sanitary vent shall be in accordance with Table 82.31-1.

Note: See Appendix for further explanatory material.

History: Cr. Register, February, 1985, No. 350, eff. 3-1-85; am. (4) 2. b., (5) (b) 2. intro., c. and (c) 4. b., Register, August, 1991, No. 428, eff. 9-1-91; am. (4) (a) 2. c. and g., 3. a., (5) (b) 1. f. and j., 3. a., (c) 1., (8) (a) 2. c., r. and recr. (5) (a) 1., r. (5) (b) 3. e. and (c) (intro.), renum. (5) (b) 3. f. to be (5) (b) 3. e., Register, February, 1994, No. 458, eff. 3-1-94.

Comm 82.35 Cleanouts. (1) **SCOPE.** The provisions of this section set forth the requirements for the installation of cleanouts and manholes for all drain piping.

(2) **MATERIALS.** Cleanouts shall be constructed of approved materials in accordance with ch. Comm 84.

(3) **WHERE REQUIRED.** (a) *Horizontal drains.* All horizontal drains within or under a building shall be accessible through a cleanout. Cleanouts shall be located so that the developed length of drain piping between cleanouts does not exceed 75 feet. For the purpose of this requirement, cleanouts in drain stacks may serve horizontal drains.

Note: See Appendix for further explanatory material.

(b) *Sanitary building sewers.* 1. Sanitary building sewers 6 inches or less in diameter shall be provided with cleanouts or manholes such that:

a. Cleanouts are located not more than 100 feet apart;

b. Manholes are located not more than 400 feet apart;

c. The distance from a cleanout to a manhole located upstream is not more than 200 feet; or

d. The distance from a manhole to a cleanout located upstream is not more than 300 feet.

2. Sanitary building sewers 8 inches or larger in diameter shall be provided with manholes at:

a. Every change in direction of 45° or more;

b. Every change in pipe diameter; and

c. Intervals of not more than 400 feet.

(c) *Storm building sewers.* 1. Storm building sewers 10 inches or less in diameter shall be provided with cleanouts or manholes such that:

- a. Cleanouts are located not more than 100 feet apart;
- b. Manholes are located not more than 400 feet apart;
- c. The distance from a cleanout to a manhole located upstream is not more than 200 feet; or
- d. The distance from a manhole to a cleanout located upstream is not more than 300 feet.

2. Storm building sewers 12 inches or larger in diameter shall be provided with manholes or storm drain inlets with an inside diameter of at least 36 inches at:

- a. Every change in direction of 45° or more;
- b. Every change in pipe diameter; and
- c. Intervals of not more than 400 feet.

(d) *Private interceptor main sewers.* 1. Private interceptor main sewers 5 inches or less in diameter shall be provided with a cleanout or manhole at the most upstream point of the private interceptor main sewer and such that:

- a. Cleanouts are located not more than 100 feet apart;
- b. Manholes are located not more than 400 feet apart;
- c. The distance from a cleanout to a manhole located upstream is not more than 200 feet; or
- d. The distance from a manhole to a cleanout located upstream is not more than 300 feet.

2. Private interceptor main sewers 6 inches or larger in diameter shall be provided with a manhole at:

- a. The most upstream point of the private interceptor main sewer;
- b. Every change in direction;
- c. Every change in pipe diameter; and
- d. Intervals of not more than 400 feet.

(e) *Junction of building drain and building sewer.* A cleanout shall be provided near the junction of a building drain and a building sewer.

1. The cleanout shall be located within 5 feet of where the building drain and the building sewer connect. The cleanout may be located either inside or outside the building.

2. A cleanout in a drain stack may serve as the cleanout at the junction of the building drain and building sewer, if the stack is within 5 feet of where the building drain and building sewer connect.

(f) *Stacks.* Where a cleanout is provided in a drain stack, the cleanout shall be located 28 to 60 inches above the lowest floor penetrated by the stack.

(g) *Branches.* Cleanouts shall be provided in connection with batteries of fixtures at such points that all parts of the branch drain pipes may be reached for cleaning or removal of stoppages. For the purposes of this requirement, removable fixture traps may serve as a cleanout opening.

(h) *Greasy wastes.* Drain pipes carrying greasy wastes shall be provided with cleanouts located not more than 40 feet apart and at all changes in direction of more than 45°.

(i) *Double sanitary tees.* A cleanout shall be provided immediately above or below a double sanitary tee drain fitting which is installed in a vertical drain pipe of less than 3 inches in diameter, unless a stack cleanout is provided in accordance with par. (f).

(j) *Traps and fixture drains.* 1. All traps shall be constructed or installed so that stoppages may be removed from the traps and the horizontal portions of fixture drains.

2. If a trap is not accessible for removal or does not contain a removable dip, a cleanout or a removable inlet shall be installed to enable cleaning of the trap passageway and the horizontal portions of the fixture drain.

(k) *Conductors.* Where a cleanout is provided in a conductor, the cleanout shall be located 28 to 60 inches above the lowest floor penetrated by the conductor.

(L) *Sampling manholes.* Municipalities or sanitary sewage districts by ordinance or rule may require the installation of sampling manholes for periodic sewage monitoring.

Note: The installation of sampling manholes may be needed for the monitoring of industrial wastes under chs. NR 200 to 299. See Appendix for further explanatory material.

(4) *DIRECTION OF FLOW.* Every cleanout shall be installed so as to open in the direction of the waste flow or at a right angle thereto.

(5) *ACCESSIBILITY.* Cleanout plugs shall not be covered with cement, plaster, or any other similar permanent finishing material.

(a) *Underground piping.* Cleanouts installed in underground drain piping shall be extended vertically to or above the finish grade.

1. The cleanout extension to grade shall connect to the drain piping through a wye pattern fitting.

2. A cleanout located outside of a building shall be provided with a frost sleeve.

a. The frost sleeve shall be of a material approved for building sewers in accordance with s. Comm 84.30 (2) (c).

b. Where a cleanout is located in an area subject to vehicular traffic the top of the frost sleeve shall terminate in a concrete pad at least 4 inches thick and extending at least 9 inches from the sleeve on all sides, sloping away from the sleeve.

c. The bottom of the frost sleeve shall terminate 6 to 12 inches above the top of the drain piping or at least 6 inches below the predicted frost depth in accordance with s. Comm 82.30 Table 82.30-6.

d. The frost sleeve shall have a removable watertight top of sufficient thickness and strength to sustain the weight of anticipated traffic.

Note: See Appendix for further explanatory material.

(b) *Concealed piping.* Cleanout access for drain piping located in concealed spaces shall be provided by either extending the cleanout to at least the surface of a wall or floor or by providing access panels of a sufficient size to permit removal of the cleanout plug and proper cleaning of the pipe.

(6) *CLEANOUT SIZE.* Cleanouts and cleanout extensions shall be sized in accordance with Table 82.35.

(7) *PROHIBITED USE OF CLEANOUT OPENINGS.* Cleanout openings shall not be used for the installation of fixtures or floor drains, except where another cleanout of equal access and capacity is provided.

(8) *MANHOLES.* (a) *Diameter.* The minimum diameter of manholes shall be 42 inches. A manhole shall have a minimum access opening of 24 inches.

(b) *Materials.* Manholes shall be constructed of approved materials in accordance with ch. Comm 84 and in accordance with the design provisions of s. NR 110.13.

Note: The provisions of NR 110.13 regarding the manhole's flow channel, watertightness, and drop pipe indicate the following specifications:

—The flow channel through manholes shall be made to conform to the shape and slope of the sewer.

—Solid watertight manhole covers are to be used wherever the manhole tops may be flooded by street runoff or high water. Where groundwater conditions are unfavorable, manholes of brick or block shall be waterproofed on the exterior with plastic coatings supplemented by a bituminous waterproof coating or other approved coatings. Inlet and outlet pipes are to be joined to the manhole with a gasketed flexible watertight connection or any watertight connection arrangement that allows differential settlement of the pipe and manhole wall to take place.

—An outside drop pipe is to be provided for a sewer entering a manhole where the invert elevation of the entering sewer is 2 feet or more above the spring line of the outgoing sewer. The entire drop connection shall be encased in the concrete. Inside drop connection may be approved on a case-by-case basis.

Note: See Appendix for further explanatory material.

Table 82.35

CLEANOUT SIZES

Diameter of Pipe Served by Cleanout (inches)	Minimum Diameter of Cleanout Extension (inches)	Minimum Diameter of Cleanout Opening (inches)
1½	1½	1½
2	1½	1½
3	3	2½
4	4	3½
5	5	4
6	6	5
8 and larger	6	6

History: Cr. Register, February, 1985, No. 350, eff. 3-1-85; am. (3) (i), r. and rec. (3) (j), Register, May, 1988, No. 389, eff. 6-1-88; am. (5) (a) 2. a., Register, August, 1991, No. 428, eff. 9-1-91; r. and rec. (3) (j) and (5) (a) 2. c., Register, February, 1994, No. 458, eff. 3-1-94.

Comm 82.36 Storm and clear water drain systems.

(1) **SCOPE.** The provisions of this section set forth the requirements for the design and installation of storm and clear water drain systems including storm building drains and sewers.

(2) **MATERIALS.** All storm and clear water drain systems shall be constructed of approved materials in accordance with ch. Comm 84.

(3) **DISPOSAL.** (a) *Storm sewer.* Storm water, surface water, groundwater and clear water wastes shall be discharged to a storm sewer system or a combined sanitary-storm sewer system where available. Combined public sanitary-storm sewer systems shall be approved by the department of natural resources. Combined private sanitary-storm sewer systems shall be approved by the department.

(b) *Other disposal methods.* 1. Where no storm sewer system or combined sanitary-storm sewer system is available or adequate to receive the anticipated load, the final disposal of the storm water, surface water, groundwater or clear water wastes shall be discharged in accordance with local governmental requirements. If the final disposal of such waters or wastes is by means of subsurface discharge, documentation shall be submitted to this department to determine whether the method of disposal is acceptable.

2. Where approved by the local governmental authority, storm water, surface water, groundwater and clear water wastes of the properties of one- and 2-family dwellings may be discharged onto flat areas, such as streets or lawns, so long as the water flows away from the buildings and does not create a nuisance.

3. a. The clear water wastes from a drinking fountain, water heater relief valve, storage tank relief valve or water softener shall be discharged to either a sanitary drain system or a storm drain system.

b. The clear water wastes from equipment other than those listed in subd. 3. a. may be discharged to a sanitary drain system if not more than 20 gallons of clear water wastes per day per building are discharged.

(c) *Segregation of wastes.* 1. a. Except as provided in subd. 1. b., where a sanitary sewer system and a storm sewer system are available the drain piping for storm water or clear water wastes may not connect to any part of the sanitary drain system.

b. Where a combined sanitary-storm sewer system is available storm water wastes, clear water wastes and sanitary wastes may not be combined until discharging to the building sewer.

2. Storm water wastes and clear water wastes shall not be combined until discharging into the storm building drain.

(4) **LOAD ON DRAIN PIPING.** (a) *Storm water drainage.* The load factor on storm water drain piping shall be computed in terms of gallons per minute or on the square footage of the horizontal projection of roofs, paved areas, yards and other tributary areas.

(b) *Continuous flow devices.* Where there is a continuous or semicontinuous discharge into the storm building drain or storm building sewer, as from a pump, air conditioning unit, or similar

device, each gallon per minute of such discharge shall be computed as being equivalent to 26 square feet of roof area.

(5) SELECTING SIZE OF STORM AND CLEAR WATER DRAIN PIPING.

(a) *Horizontal storm water drain piping.* The pipe size for horizontal drain piping for storm water shall be determined from Tables 82.36-1 to 82.36-4.

(b) *Vertical conductors for storm water.* 1. A vertical conductor for storm water shall not be smaller than the largest horizontal branch connected thereto.

2. Vertical conductors shall be sized in accordance with Table 82.36-5 or the diameter D, where

$$D = 1.128 \sqrt{\frac{A}{X}}$$

where, A = the area of the roof in square feet

X = 300 square feet per square inch for a roof covered with gravel or slag and with a pitch not exceeding ¼ inch per foot; or

= 250 square feet per square inch for a roof covered with gravel or slag and with a pitch of greater than ¼ inch per foot; or

= 200 square feet per square inch for a roof with a metal, tile, brick or slate covering and of any pitch.

(c) *Clear water drain piping.* Drain piping for clear water shall be sized in accordance with s. Comm 82.30 (3) and (4).

Table 82.36-1

MINIMUM SIZE OF STORM WATER HORIZONTAL DRAIN PIPING SERVING ROOF AREAS

Pipe Diameters (in inches)	Maximum Roof Areas (in square feet)			
	Pitch of Piping Per Foot			
	1/16 inch	1/8 inch	1/4 inch	1/2 inch
3	650	910	1,300	1,820
4	1,300	1,950	2,990	3,770
5	2,470	3,640	5,070	7,020
6	4,160	5,980	8,320	11,700
8	9,320	13,000	18,200	26,000
10	17,680	24,700	33,800	50,440
12	27,300	41,080	57,200	81,900
15	52,000	72,800	105,300	146,640
18	85,800	121,550	174,200	247,000
21	156,520	179,660	256,880	374,400
24	187,200	261,560	382,200	546,000

Note: Divide square footage by 26 to obtain flow in gpm.

Table 82.36-2

MINIMUM SIZE OF STORM WATER HORIZONTAL DRAIN PIPING SERVING PAVED OR GRAVELED GROUND SURFACE AREAS

Pipe Diameters (in inches)	Maximum Surface Areas (in square feet)			
	Pitch of Piping Per Foot			
	1/16 inch	1/8 inch	1/4 inch	1/2 inch
3	810	1,140	1,625	2,270
4	1,625	2,430	3,740	4,720
5	3,090	4,550	6,350	8,760
6	5,200	7,470	10,400	14,600
8	11,650	16,250	22,750	32,600
10	22,100	30,850	44,250	63,000
12	34,150	52,300	71,500	102,200
15	65,000	91,000	131,500	183,000
18	107,000	152,000	210,800	321,000
21	195,000	224,000	321,000	468,000
24	234,000	336,000	478,000	682,000

Note: Divide square footage by 32.5 to obtain flow in gpm.

(d) *Minimum size of underground drain piping.* Any portion of a storm or clear water drain system installed underground shall not be less than 2 inches in diameter. Underground drain piping which is 2 inches in diameter shall not exceed a length of 20 feet.

(e) *Minimum size of storm building sewers.* The pipe size for storm building sewers shall be determined from Tables 82.36-1 to 82.36-4. Storm building sewers serving combined storm water and clear water wastes shall be sized in accordance with Table 82.36-4.

1. Gravity flow sewers. a. The minimum size of a gravity flow storm building sewer shall be 3 inches in diameter between the building and lot line and 4 inches in diameter between the lot line and public sewer or private interceptor main sewer. A municipality or sanitary district by ordinance may require that portion of the storm building sewer between the lot line and public sewer or private interceptor sewer to be larger than 4 inches in diameter.

b. A gravity flow storm building sewer shall not be smaller than any storm building drain connected thereto, except a decrease in diameter in the direction of flow will be permitted if the increase in slope is sufficient to maintain the volume rate of flow. A reduction in diameter for the storm building sewer shall be made in a manhole.

2. Pressurized or forced sewers. Pressurized storm building sewers shall be not less than 1 1/4 inches in diameter.

Table 82.36-3

MINIMUM SIZE OF STORM WATER HORIZONTAL DRAIN PIPING SERVING LAWNS, PARKS AND SIMILAR LAND SURFACES

Pipe Diameters (in inches)	Maximum Surface Areas (in square feet)			
	Pitch of Piping Per Foot			
	1/16 inch	1/8 inch	1/4 inch	1/2 inch
3	2,600	3,640	5,200	7,280
4	5,200	7,800	11,960	15,080
5	9,880	13,560	20,280	28,080
6	16,640	23,920	33,280	46,800
8	37,280	52,000	72,800	112,000
10	69,720	98,800	135,200	201,760
12	109,200	164,320	228,800	327,600
15	208,000	291,200	421,200	586,560
18	343,200	490,200	596,800	988,000
21	626,080	718,640	1,027,520	1,497,600
24	748,800	1,046,240	1,528,800	2,184,000

Note: Divide square footage by 104 to obtain flow in gpm.

Table 82.36-4

MAXIMUM CAPACITY OF STORM WATER HORIZONTAL DRAIN PIPING FLOWING FULL

Pipe Diameters (in inches)	Maximum Capacities in Gallons Per Minute			
	Pitch of Piping Per Foot			
	1/16 inch	1/8 inch	1/4 inch	1/2 inch
3	25	35	50	70
4	59	75	115	145
5	97	140	195	270
6	160	230	320	450
8	355	500	700	1,000
10	680	950	1,300	1,940
12	1,050	1,580	2,200	3,150
15	2,000	2,800	4,050	5,640
18	3,300	4,675	6,700	9,500
21	6,020	6,910	9,880	14,400
24	7,200	10,060	14,700	21,000

(6) **PITCH OF HORIZONTAL DRAIN PIPING.** All horizontal drain piping shall be installed at a pitch which will produce a computed velocity of at least one foot per second when flowing full.

(a) *Storm water drain piping.* The minimum pitch of horizontal drain piping shall be in accordance with Tables 82.36-1 to 82.36-4.

(b) *Clear water drain piping.* The minimum pitch of horizontal clear water drain piping less than 3 inches in diameter shall be 1/8 inch per foot. The minimum pitch of horizontal drain piping 3 inches or larger in diameter shall be 1/16 inch per foot.

(7) **CHANGES IN DIRECTION OF FLOW.** Changes in direction of flow for storm and clear water drain piping shall be in accordance with s. Comm 82.30 (8).

(8) **DRAINAGE FITTINGS AND CONNECTIONS.** Drain piping fittings and connections shall be in accordance with s. Comm 82.30 (9).

(9) **STACK OFFSETS.** Stack offsets in clear water drain piping shall comply with s. Comm 82.30 (6).

(10) **FIXTURE BRANCH CONNECTIONS NEAR BASE OF STACK.** Branch drains from interior clear water inlets shall not connect downstream from the base fitting or fittings of a drain stack or conductor within the distance equal to 20 pipe diameters of the building drain.

(11) **SUMPS AND PUMPS.** (a) *Sumps.* 1. General. All storm building subdrains shall discharge into a sump, the contents of which shall be automatically lifted and discharged into the storm drain system.

2. Construction and installation. The sump shall have a rim extending at least one inch above the floor immediately adjacent to the sump, except where the sump is installed in an exterior meter pit. The sump shall have a removable cover of sufficient strength for anticipated loads. The sump shall have a solid bottom.

3. Location. All sumps installed for the purpose of receiving clear water, basement or foundation drainage water shall be located at least 15 feet from any water well.

4. Size. The size of each clear water sump shall be as recommended by the sump pump manufacturer, but may not be smaller than 16 inches in diameter at the top, 14 inches in diameter at the bottom, and 22 inches in depth.

5. Removable covers. Penetrations through the top of removable sump covers shall be limited to those for the electrical supply, the vent piping and the discharge piping for the pump or pumps.

(b) *Sump pump systems.* 1. Pump size. The pump shall have a capacity appropriate for anticipated use.

2. Discharge piping. Where a sump discharges into a storm building drain or sewer, a free flow check valve shall be installed.

(12) **SUBSOIL DRAINS.** Where a subsoil drain for a building is subject to backwater, it shall be protected by an accessible backwater valve or a sump with pump. Subsoil drains may discharge into an area drain, drain tile receiver or a sump with pump.

(13) **STORM BUILDING DRAINS AND SEWERS.** (a) *Limitations.* No storm building sewer or private interceptor main storm sewer may pass through or under a building to serve another building, unless:

1. The storm building sewer or private interceptor main storm sewer serves farm buildings or farm houses or both which are all located on one property; or

2. A petition for variance is granted under s. Comm 82.20 (11). The approval or nonapproval of a petition for variance request relative to this paragraph shall be determined on an individual basis and shall be evaluated on site specific conditions including, at least, whether:

a. The storm building sewer or private interceptor main storm sewer serves only buildings which are all located on one property;

Table 82.36-5

MINIMUM DIAMETER OF VERTICAL CONDUCTORS

Type of Roof	Maximum Roof Areas (in square feet)					
	Pipe Diameters (in inches)					
	2½	3	4	5	6	8
Roofs covered with gravel, slag, or similar material and with a pitch of ¼" per foot or less.	1,645	2,120	3,780	5,885	8,490	15,125
Roofs covered with gravel, slag or similar material and with a pitch greater than ¼" per foot.	1,220	1,770	3,150	4,905	7,075	12,600
Roofs covered with metal, tile, brick, slate or similar material and of any pitch.	975	1,415	2,520	3,925	5,660	10,080

Note: Divide square footage by 26 to obtain flow in gpm.

b. The functions or operations of the buildings to be served by the building sewer or interceptor main sewer are related; or

c. A document, which indicates the piping and distribution arrangement for the property and buildings, will be recorded with the register of deeds.

(b) *Extensions to grade.* 1. The connection of a storm water leader discharging to a storm building sewer shall be made above the finished grade.

2. The diameter of the drain piping connecting a storm water leader to a storm building drain or sewer shall be in accordance with sub. (5).

(c) *Other requirements.* 1. The elevation of storm building drains shall comply with s. Comm 82.30 (11) (b) 1.

2. Storm building drains subject to backflow or backwater shall be protected in accordance with s. Comm 82.30 (11) (b) 2.

3. The location of storm building drains and building sewers shall be in accordance with s. Comm 82.30 (11) (d).

4. Storm building drains and building sewers shall be installed in accordance with s. Comm 82.30 (11) (e).

5. Storm building sewers shall be connected to main sewers in accordance with s. Comm 82.30 (11) (f).

(14) **WASTES.** (a) Traps shall be required for interior drain inlets receiving clear water wastes.

(b) Traps shall not be required for roof drains or exterior area drains for storm water waste, unless the drain inlet is located within 10 feet of an air inlet, door or openable window. Where a trap is required, the trap may be located inside the building. More than one drain inlet may discharge to the same trap.

(c) Where a subsoil drain discharges by gravity to a storm sewer the drain shall be trapped. Such a trap shall be provided with a cleanout.

(15) **VENTS.** (a) A trap receiving clear water wastes shall be vented in accordance with s. Comm 82.31. Vent piping for a clear water drain system shall not be connected to a vent system serving a sanitary drain system or chemical waste system.

(b) Vents shall not be required for traps which receive only storm water or groundwater wastes.

(16) **INTERIOR DRAIN INLETS.** Interior clear water drain inlets shall terminate at least one inch above the finished floor.

(17) **AREA DRAIN INLETS.** (a) *Drain inlet design and construction.* 1. General. Storm water area drain inlets shall be constructed in a watertight and substantial manner of approved materials in accordance with ch. Comm 84.

2. Inlet base. All site-constructed storm water area drain inlets subject to vehicular traffic shall be set on a 6 inch thick air-entrained concrete base with a minimum estimated compressive

strength at 28 days of 3000 psi or on an approved precast concrete base.

3. **Size.** The size of masonry or concrete inlet basins shall be in accordance with subd. 3. a. and b.

a. Inlet basins 36 inches or less in depth shall have a minimum inside diameter of 24 inches. Basins shall be provided with an open bar grate not less than 18 inches in diameter.

b. Inlet basins with a depth greater than 36 inches shall have a minimum inside diameter of 36 inches. Basins shall be provided with an open bar grate not less than 24 inches in diameter.

4. **Inlet grates.** All inlets shall have an approved, well fitted, removable cast iron or steel grate of a thickness and strength to sustain anticipated loads. The grate shall have an available inlet area equal to or greater than the required waste outlet of the inlet.

Note: See Appendix for further explanatory material.

(b) **Subsurface areas of 50 square feet or less.** All subsurface areas, exposed to the weather, other than stairwells, with areas not exceeding 50 square feet shall be drained. These areas may drain to subsoil drains through a minimum 2 inch diameter pipe or a continuous layer of gravel or may drain to the storm building drain, storm subdrain, or storm sewer through a minimum 3 inch diameter pipe.

(c) **Subsurface areas of more than 50 square feet and stairwells.** An area drain shall be provided in subsurface areas, greater than 50 square feet in area, and all stairwells which are exposed to the weather. These areas shall be drained to the storm building drain, storm subdrain or storm sewer. If no storm sewer exists, the discharge shall be in accordance with sub. (3) (b). The fixture drain shall have a minimum inside diameter of 3 inches and shall not discharge into a subsoil, footing or foundation drain.

(18) **ROOF DRAINS.** (a) **General roofs.** Roof drains shall be equipped with strainers extending not less than 4 inches above the surface of the roof immediately adjacent to the roof drain. Strainers shall have an available inlet area above the roof of not less than 1-1/2 times the area of the conductor to which the drain connects.

(b) **Flat decks.** Roof drain strainers for use on sun decks, parking decks and similar areas may be of the flat surface type level with the deck, and shall have an available inlet area of not less than twice the area of the conductor to which the drain connects.

(19) **CONTROLLED FLOW ROOF DRAIN SYSTEMS.** (a) **Application.** In lieu of sizing the roof storm drain piping on the basis of actual maximum horizontal projected roof areas as specified in sub. (4), the roof drain piping may be sized based on the equivalent adjusted maximum horizontal projected roof areas which result from controlled flow and storage of storm water on the roof.

Note: See s. ILHR 53.11 (4) (d) as to provisions relating to the structural design of the roof for controlled flow drain systems.

(b) **Installation.** Control of storm water runoff shall be by control devices. Control devices shall be protected by strainers.

(c) **Sizing.** Not less than 2 drains shall be installed in roof areas 10,000 square feet or less and at least 4 drains in roofs over 10,000 square feet in area.

History: Cr. Register, February, 1985, No. 350, eff. 3-1-85; r. and recr. (3) (a) and (b) 1., (c) 1. and (11) (a) 4., cr. (3) (c) 3., Register, May, 1988, No. 389, eff. 6-1-88; renun. (13) (a) and (b) to be (b) and (c) and am. (b) 1., cr. (3) (b) 3. and (13) (a), r. (3) (c) 3. and (13) (intro.), Register, August, 1991, No. 428, eff. 9-1-91; reprinted to correct error in (5) (c) 2., Register, October, 1991, No. 430; am. (3) (b) 1., (c) 1. a., (13) (b) 1. and (c), cr. (11) (a) 5., Register, February, 1994, No. 458, eff. 3-1-94.

Subchapter IV— Water Supply Systems

Comm 82.40 Water supply systems. (1) SCOPE. The provisions of this section set forth the requirements for the design and installation of water supply systems.

Note: Chapter NR 811 governs the design and construction of community water systems or waterworks.

(2) **MATERIALS.** All water supply systems shall be constructed of approved materials in accordance with ch. Comm 84.

(3) **GENERAL.** (a) **Potable water required.** Every piece of equipment used in the preparation or processing of food, medical or pharmaceutical products and every plumbing fixture and appliance which demands a supply of water shall be provided with only potable water.

(b) **Hot water required.** Except as provided in subds. 1. and 2., hot water shall be provided to all plumbing fixtures, appliances and equipment used for personal washing, culinary purposes or laundering.

1. Lavatories, wash fountains and shower heads which are not located in dwelling units or living units shall be supplied with either tempered water or hot water.

a. Tempered water shall be provided to lavatories, wash fountains and shower heads by means of tempering mixing valves.

2. Lavatories located in park shelters and bath houses which are not open during the period from November 15 to March 15 and which are not places of employment shall not be required to be provided with hot water.

3. Lavatories located in waysides which are not places of employment shall not be required to be provided with hot water.

Note: The exception of providing hot water under subds. 1. to 3. does not supercede the requirements of other state agencies for providing hot water.

(c) **Protection.** 1. Pursuant to s. NR 811.09 (2) the interconnection of two or more water supply systems, one system served by a public supply source and the other system served by another supply source is prohibited, unless approved in writing by the department of natural resources.

2. A water supply system shall be designed and installed in accordance with s. Comm 82.41 and maintained to prevent non-potable liquids, solids or gases from being introduced into the potable water supply system through cross connections.

(d) **Identification.** 1. Where a building or a structure is served by a nonpotable water distribution system and a potable water distribution system each distribution system shall be identified in accordance with this subdivision.

a. All above ground piping supplying nonpotable water shall be identified nonpotable by tags or yellow bands. The yellow bands shall be at least 3 inches wide.

b. All above ground piping supplying potable water shall be identified potable by tags or green bands. The green bands shall be at least 3 inches wide.

c. The tags or colored bands identifying nonpotable water and potable water piping shall be placed at intervals of not more than 25 feet and at each side where the piping passes through a wall, floor or roof.

d. All valves and outlets supplying nonpotable water shall be identified nonpotable by tags.

e. All valves, except fixture stop valves, supplying potable water shall be identified potable by tags.

f. Tags used to identify nonpotable water outlets, valves and piping shall be of metal or plastic in the shape of an equilateral triangle with 4 inch sides and bearing the legend "water unsafe" or other similar wording approved in writing by the department. The lettering on the tags shall be raised or indented and at least 1/2-inch in height.

g. Tags used to identify potable water valves shall be of metal or plastic in the shape of a 3-inch diameter circle bearing the legend "safe water" or other similar wording approved in writing by the department. The lettering on the tags shall be raised or indented and at least 1/2-inch in height.

2. Where a building or a structure is served by 2 distribution systems, one system supplied by a public water supply and the other system supplied by a private well, each water distribution system shall be identified to indicate the supply source.

(e) **Metering.** When a water meter is provided pursuant to s. Comm 83.18 (10) the water meter shall:

1. Be installed in the water supply system so as to exclude the supply to those water outlets, such as exterior hose bibbs and wall hydrants, which do not discharge to the sanitary drain system; and

2. Include an accessible remote reader device located on the exterior of the building or structure.

Note: Section Comm 83.18 (10) requires metering when a new building or a new structure is to be served by a holding tank for sanitary wastewater disposal.

(4) CONTROL VALVES. (a) *Private water mains.* Private water mains shall be provided with control valves as specified in this subsection.

1. Corporation cocks. a. If a private water main 2 inches or less in diameter connects to a public water main, a corporation cock shall be installed at the connection to the public water main.

b. If a private water main 2-1/2 inches or larger in diameter connects to a public water main, a corporation cock shall be installed not more than 8 feet from the connection to the public water main.

2. Curb stops. a. Except as provided in subd. 2. b., if a private water main connects to public water main, a curb stop shall be installed in the private water main between the corporation cock and the property line.

b. If a private water main 2-1/2 inches or larger in diameter connects to a public water main, one control valve may serve as the corporation cock and the curb stop. The control valve shall be located not more than 8 feet from the connection to the public water main and shall be accessible for operation.

(b) *Water services.* Water services shall be provided with control valves as specified in this subsection.

1. Corporation cocks. a. If a water service 2 inches or less in diameter connects to a public water main, a corporation cock shall be installed at the connection to the public water main.

b. If a water service 2-1/2 inches or larger in diameter connects to a public water main, a corporation cock shall be installed not more than 8 feet from the connection to the public water main.

2. Curb stops. a. Except for water services serving farm buildings and farm houses, a curb stop shall be installed in each water service which connects to a private water main. The curb stop shall be located outside the building served by the water service.

b. Except as provided in subd. 2. c., a curb stop shall be installed in each water service which connects to a public water main. The curb stop shall be located between the corporation cock and the property line.

c. If a water service 2-1/2 inches or larger in diameter connects to a public water main, one control valve may serve as the corporation cock and the curb stop. The control valve shall be located not more than 8 feet from the connection to a public water main and shall be accessible for operation.

3. Building control valves. If a water service serves a building, a building control valve shall be provided in the water service as specified in this subsection.

a. If the water service connects to a public water supply or to a private water supply which has an external pressure tank, the building control valve shall be installed inside the building and located within 3 feet of developed length from the point where the water service first enters the building. If a water meter is provided, the building control valve shall be located upstream of the water meter.

b. If a private water supply includes an internal pressure tank, the building control valve shall be installed inside the building and located within 3 feet of developed length downstream from the internal pressure tank.

Note: See Appendix for further explanatory material.

(c) *Water distribution systems.* 1. Control valves shall be installed in water distribution systems serving public buildings as specified in this subdivision.

a. If a water meter is provided, a control valve shall be installed within 3 feet of developed length downstream from the outlet of the water meter. If bypass piping is provided around a water meter, a control valve shall be installed in the bypass piping.

Note: See sub. (8) (d) 3. for the requirements relating to the bypassing of water meters.

b. A control valve shall be installed in the supply piping to each water heater and water treatment device and in the fixture supply to each plumbing fixture, plumbing appliance and piece of equipment.

c. If a hot water circulation system is provided, a control valve shall be installed on both the inlet and outlet piping to the circulation pump. If a hot water circulation system has 2 or more return pipe lines, a balancing control valve shall be installed in each return piping line.

d. The water distribution system for buildings with more than 4 dwelling units or living units shall be provided with control valves in such numbers and at such locations so that the water supplied to all the units within the building can be isolated into groups of 4 or less units.

Note: See sub. (8) (g) for the valve requirements for water temperature control.

2. Control valves shall be installed in water distribution systems serving one- and 2-family dwellings as specified in this subdivision.

a. If a water meter is provided, a control valve shall be installed within 3 feet of developed length downstream from the outlet of the water meter. If bypass piping is provided around a water meter, a control valve shall be installed in the bypass piping.

Note: See sub. (8) (d) 3. for the requirements relating to the bypassing of water meters.

b. A control valve shall be installed in the supply piping to each water heater and water treatment device and in the fixture supply to each water closet, exterior hose bibb, plumbing appliance and piece of equipment.

c. If a hot water circulation system is provided, a control valve shall be installed on both the inlet and outlet piping to the circulation pump. If a hot water circulation system has 2 or more return pipe lines, a balancing control valve shall be installed in each return piping line.

(5) HOT WATER SUPPLY SYSTEMS. (a) *General.* Water heating systems shall be sized to provide sufficient hot water to supply both the daily requirements and hourly peak loads of the building.

Note: See Appendix for further explanatory materials regarding insulation requirements for storage tanks and recirculation piping.

(b) *Temperature maintenance.* If the developed length of hot water distribution piping from the source of the hot water supply to a plumbing fixture or appliance exceeds 100 feet, a circulation system or self-regulating electric heating cable shall be provided to maintain the temperature of the hot water within the distribution piping.

1. If a circulation system is used to maintain the temperature, no uncirculated hot water distribution piping may exceed 25 feet in developed length.

2. If a self-regulating electric heating cable is used to maintain the temperature, the cable shall extend to within 25 feet of each fixture or the appliance.

3. Water distribution piping conveying circulated water or served by a self-regulating electric heating cable shall be insulated to limit the heat loss at the external surface of the pipe insulation to a maximum of 25 BTUs per hour per square foot for above-ground piping and 35 BTUs per hour per square foot for underground piping. The maximum heat loss shall be determined at a temperature differential, T, equal to the maximum water temperature minus a design ambient temperature no higher than 65° F

4. Water distribution piping served by self-regulating electric heating cable shall be identified as being electrically traced in accordance with ch. Comm 16.

5. The installation of self-regulating electric heating cable may be subcontracted by a plumber to another trade.

Note: See s. ILHR 63.29 for pipe insulation requirements.

(c) *Water heaters.* All water heaters and safety devices shall be designed and constructed in accordance with s. Comm 84.20 (5) (n).

Note: Water heaters are to be installed in accordance with the requirements specified in chs. ILHR 50 to 64 and ILHR 20 to 25 with respect to enclosures and venting.

(d) *Safety devices.* Water heaters shall be equipped with safety devices as specified in this paragraph.

1. All pressurized storage-type water heaters and unfired hot water storage tanks shall be equipped with one or more combination temperature and pressure relief valves. The temperature steam rating of a combination temperature and pressure relief valve or valves shall equal or exceed the energy input rating in BTU per hour of the water heater. No shut off valve or other restricting device may be installed between the water heater or storage tank and the combination temperature and pressure relief valve.

Note: The temperature steam rating of a combination temperature and pressure relief valve is commonly referred to as the AGA temperature steam rating.

2. All pressurized non-storage type water heaters shall be provided with a pressure relief valve installed at the hot water outlet with no shut off valve between the heater and the relief valve.

3. Temperature and pressure relief valves shall be installed so that the sensing element of the valve extends into the heater or tank and monitors the temperature in the top 6 inches of the heater or tank.

4. A vacuum relief valve shall be installed in each water heater and hot water storage tank which, when measured from the bottom of the heater or tank, is located more than 20 feet above any faucet or outlet served by the heater or tank.

5. Every relief valve which is designed to discharge water or steam shall be connected to a discharge pipe.

a. The discharge pipe and fittings shall be made of a material acceptable for water distribution piping in accordance with s. Comm 84.30 (4) (e) 1.

b. The discharge pipe and fittings shall have a diameter not less than the diameter of the relief valve outlet.

c. The discharge pipe may not be trapped.

d. No valve may be installed in the discharge pipe.

e. The discharge pipe shall be installed to drain by gravity flow to a floor served by a floor drain or to a receptor in accordance with s. Comm 82.33 (8). The outlet of the discharge pipe shall terminate within 6 inches over the floor or receptor, but not less than a distance equal to twice the diameter of the outlet pipe. The outlet of the discharge pipe may not be threaded.

f. The discharge pipe for a water heater shall terminate within the same room or enclosure within which the water heater or hot water storage tank is located.

(e) *Controls.* 1. All hot water supply systems shall be equipped with automatic temperature controls capable of adjustments from the lowest to the highest acceptable temperature settings for the intended use.

2. A separate means shall be provided to terminate the energy supplied to each water heater and each hot water circulation system.

(6) **LOAD FACTORS FOR WATER SUPPLY SYSTEMS.** (a) *Intermittent flow fixtures.* The load factor for intermittent flow fixtures on water supply piping shall be computed in terms of water supply fixture units as specified in Tables 82.40-1 and 82.40-2 for the corresponding fixture and use. Water supply fixture units may be converted to gallons per minute in accordance with Table 82.40-3.

Table 82.40-1
WATER SUPPLY FIXTURE UNITS FOR
NONPUBLIC USE FIXTURES

TYPE OF FIXTURE ^a	WATER SUPPLY FIXTURE UNITS (WSFU)		
	Hot	Cold	Total
Automatic Clothes Washer	1.0	1.0	1.5
Bar Sink	0.5	0.5	1.0
Bathtub, with or without Shower Head	1.5	1.5	2.0
Bidet	1.0	1.0	1.5
Dishwashing Machine	1.0		1.0
Glass Filler		0.5	0.5
Hose Bibb:			
1/2" diameter		3.0	3.0
3/4" diameter		4.0	4.0
Kitchen Sink	1.0	1.0	1.5
Laundry Tray, 1 or 2 Compartment	1.0	1.0	1.5
Lavatory	0.5	0.5	1.0
Shower, Per Head	1.0	1.0	1.5
Water Closet, Flushometer Type		6.0	6.0
Water Closet, Gravity Type Flush Tank		2.0	2.0
Bathroom Groups:			
Bathtub, Lavatory and Water Closet-FM ^b	2.0	7.5	8.0
Bathtub, Lavatory and Water Closet-FT ^c	2.0	3.5	4.0
Shower Stall, Lavatory and Water Closet-FM	1.5	7.0	7.5
Shower Stall, Lavatory and Water Closet-FT	1.5	3.0	3.5

a: For fixtures not listed, factors may be assumed by comparing the fixture to a listed fixture which uses water in similar quantities and at similar rates.

b: FM means flushometer type.

c: FT means flush tank type.

(b) *Continuous flow devices.* The load factor for equipment which demands a continuous flow of water shall be computed on the basis of anticipated flow rate in terms of gallons per minute.

(7) **SIZING OF WATER SUPPLY PIPING.** The sizing of the water supply system shall be based on the empirical method and limitations outlined in this subsection or on a detailed engineering analysis acceptable to the department.

(a) *Methodology.* The determination of minimum pipe sizes shall take into account the pressure losses which occur throughout the entire water supply system and the flow velocities within the water distribution system. Calculations for sizing a water distribution system shall include:

1. The load factor in water supply fixture units or gallons per minute on the piping;

2. The minimum pressure available from the water main or pressure tank;

3. The pressure loss due to the differences in elevation from the:

a. Water main or pressure tank to the building control valve; and

b. Building control valve to the controlling plumbing fixture;

Table 82.40-2

WATER SUPPLY FIXTURE UNITS FOR
PUBLIC USE FIXTURES

TYPE OF FIXTURE ^a	WATER SUPPLY FIXTURE UNITS (WSFU)		
	Hot	Cold	Total
Automatic Clothes Washer, Individual	2.0	2.0	3.0
Automatic Clothes Washer, Large Capacity	b	b	b
Bathtub, With or Without Shower Head	2.0	2.0	3.0
Coffeemaker		0.5	0.5
Dishwasher, Commercial	b	b	b
Drink Dispenser		0.5	0.5
Drinking Fountain		0.25	0.25
Glass Filler		0.5	0.5
Hose Bibb:			
1/2" diameter		3.0	3.0
3/4" diameter		4.0	4.0
Icemaker		0.5	0.5
Lavatory	0.5	0.5	1.0
Shower, Per Head	2.0	2.0	3.0
Sinks:			
Bar and Fountain	1.5	1.5	2.0
Barber and Shampoo	1.5	1.5	2.0
Cup		0.5	0.5
Flushing Rim		7.0	7.0
Kitchen and Food Preparation per faucet	2.0	2.0	3.0
Laboratory	1.0	1.0	1.5
Medical Exam and Treatment	1.0	1.0	1.5
Service	2.0	2.0	3.0
Surgeon Washup	1.5	1.5	2.0
Urinal:			
Syphon Jet		4.0	4.0
Washdown		2.0	2.0
Wall Hydrant, Hot and Cold Mix:			
1/2" diameter	2.0	2.0	3.0
3/4" diameter	3.0	3.0	4.0
Wash Fountain:			
Semicircular	1.5	1.5	2.0
Circular	2.0	2.0	3.0
Water Closet:			
Flushometer		7.0	7.0
Gravity Type Flush Tank		3.0	3.0

a: For fixtures not listed, factors may be assumed by comparing the fixture to a listed fixture which uses water in similar quantities and at similar rates.
b: Load factors in gallons per minute, gpm, based on manufacturer's requirements.

Table 82.40-3

CONVERSION OF WATER SUPPLY FIXTURE UNITS
TO GALLONS PER MINUTE

Water Supply Fixture Units	GALLONS PER MINUTE	
	Predominately Flushometer Type Water Closets or Syphon Jet Urinals	Predominately Flush Tank Type Water Closets or Wash- down Urinals
1	—	1
2	—	2
3	—	3
4	10	4
5	15	4.5
6	18	5
7	21	6
8	24	6.5
9	26	7
10	27	8
20	35	14
30	40	20
40	46	24
50	51	28
60	54	32
70	58	35
80	62	38
90	65	41
100	68	42
120	73	48
140	78	53
160	83	57
180	87	61
200	92	65
250	101	75
300	110	85
400	126	105
500	142	125
600	157	143
700	170	161
800	183	178
900	197	195
1000	208	208
1250	240	240
1500	267	267
1750	294	294
2000	321	321
2250	348	348
2500	375	375
2750	402	402
3000	432	432
4000	525	525
5000	593	593

Note: Values not specified in the table may be calculated by interpolation.

4. The pressure losses due to flow through water heaters, water treatment devices, water meters and backflow preventers;

5. The minimum flow pressure needed at the controlling plumbing fixture; and

6. The pressure losses due to flow friction through piping, fittings, valves and other plumbing appurtenances. This pressure loss may be calculated in terms of equivalent lengths of piping. The equivalent length of piping to a controlling plumbing fixture, including fittings, valves and other appurtenances, may be obtained by multiplying the developed length by 1.5.

Note: See Appendix for further explanatory material.

(b) *Private water mains and water services.* Private water mains and water services shall be designed to supply water to the water distribution systems to maintain the minimum flow pressures specified in par. (d), but shall not be less than 3/4 inch in diameter.

Note: See Appendix for further explanatory material.

(c) *Maximum loading.* The calculated load on any portion of the water distribution system may not exceed the limits specified in Tables 82.40-4 to 82.40-9.

(d) *Pressure.* 1. Except as provided in subd. 1. a. to c., water supply systems shall be designed to provide at least 8 psig of flow pressure at the outlets of all fixture supplies.

a. The flow pressure at the outlets of the fixture supplies serving syphonic type urinals, washdown type urinals and water closets, and syphonic type flushometer water closets shall be at least 15 psig.

b. The flow pressure at the outlets of the fixture supplies serving one piece tank type water closets, pressure balance mixing valves, and thermostatic mixing valves shall be at least 20 psig.

c. The flow pressure at the outlets of the fixture supplies serving blowout type urinals and blowout type water closets shall be at least 25 psig.

2. a. Except as provided in subd. 3., if the water pressure available from a water main or private water supply exceeds 80 psig, a pressure reducing valve and strainer, if a strainer is not a component of the valve, shall be installed in the water distribution system.

b. A pressure reducing valve required under subd. 2. a. shall be installed upstream from all plumbing fixtures and plumbing appliances and downstream from the water meter of an utility, if a meter is provided.

3. A pressure reducing valve shall not be required to be installed in a water distribution system which supplies water directly to a water pressure booster pump.

4. If the pressure available from the water main or private water supply is inadequate by calculation to provide the minimum pressures specified in subd. 1., a hydro pneumatic pressure booster system or a water pressure booster pump shall be installed to increase the supply of water.

a. Each water pressure booster pump shall be provided with an automatic low pressure cut-off switch. The cut-off switch shall be located on the inlet side of the pump and shall be set to terminate the energy supplied to the pump when a positive pressure of less than 10 psig occurs.

b. A vacuum relief valve not less than one-half inch in diameter shall be installed in each water pressure tank, if the bottom of the pressure tank is more than 20 feet above any water supply outlet served by the pressure tank.

(e) *Maximum velocity.* A water distribution system shall be designed so that the flow velocity does not exceed 8 feet per second.

(f) *Minimum sizes.* 1. Water distribution piping 1/2 inch in diameter serving 2 or more plumbing fixtures may not have a load of more than 2 water supply fixture units.

2. Water distribution piping 1/2 inch in diameter serving a shower which is not individually pressure balanced or individu-

ally thermostatically blended may not serve any additional fixtures.

(g) *Minimum sizes for fixture supplies.* Except as provided in subds. 1. to 3., the fixture supplies serving all plumbing fixtures, appliances and pieces of equipment shall be at least 1/2 inch in diameter.

1. Fixture supplies serving syphon jet type urinals shall be at least 3/4 inch in diameter.

2. Fixture supplies serving flushometer type water closets shall be at least one inch in diameter.

3. Fixture supplies serving emergency eye wash or shower outlets shall be not less than recommended by the manufacturer.

(h) *Maximum lengths for fixture supply connectors.* 1. a. A fixture supply connector may not exceed more than 24 inches in developed length from a plumbing fixture or the body of a faucet, except as provided in subd. 1. b.

b. A fixture supply connector may not exceed more than 10 feet in developed length from a single faucet or outlet to a water cooler device, water heater, or water treatment device which is to individually serve the faucet or outlet.

2. Fixture supply connectors may not extend more than 10 feet in developed length from a plumbing appliance.

(B) *INSTALLATION.* (a) *Frost protection.* 1. Adequate measures shall be taken to protect all portions of the water supply system from freezing. All private water mains and water services shall be installed below the predicted depths of frost specified in s. Comm 82.30 (11) (c) 2. d., Figure 82.30-1 and Table 82.30-6, unless other protective measures from freezing are taken.

2. A hose bibb or a hydrant that penetrates an exterior wall of a heated structure shall be a frost proof and self-draining type.

Note: See s. Comm 82.41 (4) (m) relative to cross connection control devices.

(b) *Location.* 1. Water supply piping may not be located in, under or above sanitary sewer manholes, sewage treatment tanks, holding tanks, dosing tanks, distribution boxes, soil absorption areas or seepage pits for private sewage systems.

2. Water supply piping shall be located at least 10 feet horizontally away from a sewage treatment tank, holding tank, dosing tank, distribution box, or soil absorption area for a private sewage system.

3. Water supply piping located downslope from a mound type private sewage system shall be at 25 feet horizontally away from the toe of the basal area.

Note: See also s. Comm 84.30 (4) relative to water supply piping to be installed in contaminated soils.

4. If a private water main or a water service crosses a sanitary sewer, the water piping within 10 feet of the point of crossing shall be installed:

a. At least 12 inches above the top of the sewer from the bottom of the water piping;

b. At least 18 inches below the bottom of the sewer from the top of the water piping; or

c. Within a waterproof sleeve made of materials as specified for sanitary building sewers in s. Comm 84.30 (2).

5. Private water mains and water services 2-1/2 inches or larger in diameter shall be installed at least 8 feet horizontally from any sanitary sewer. The distance shall be measured from center to center of the piping.

6. Except as provided in subd. 5., private water mains and water services 2 inches or less in diameter shall be installed at least 30 inches horizontally from any sanitary sewer. The distance shall be measured from center to center of the piping.

7. Private water mains and water services 2 inches or less in diameter may be installed less than 30 inches horizontally from a sanitary sewer, if the bottom of the water piping is installed at least 12 inches above the sewer, except that portion of a water service within 5 feet of developed length from the point where the water

service first enters the building may be less than 12 inches above the sewer.

8. No private water main or water service may be installed within 6 inches of a storm sewer.

(c) *Limitations.* No private water main or water service may pass through or under a building to serve another building, unless:

1. The private water main or water service serves farm buildings or farm houses or both which are all located on one property; or

2. A petition for variance is granted under s. Comm 82.20 (11). The approval or nonapproval of a petition for variance request relative to this paragraph shall be determined on an individual basis and shall be evaluated on site specific conditions including, at least, whether:

a. The private water main or water service serves only buildings which are all located on one property;

b. The functions or operations of the buildings to be served by the water main or water service are related; or

c. A document, which indicates the piping and distribution arrangement for the property and buildings, will be recorded with the register of deeds.

(d) *Water distribution piping.* 1. Water distribution piping shall be supported in accordance with s. Comm 82.60.

2. Provisions shall be made to evacuate all water out of the water distribution system.

3. Except where parallel water meters are installed, water distribution piping shall be provided to bypass a water meter 1½ inches or larger.

4. Water distribution piping shall be provided to bypass a water softener and an iron removal device. The bypass piping may be an internal part of the water softener or the iron removal device.

(e) *Valves.* 1. All control valves installed in a water service, except a valve serving only as a corporation cock, shall be accessible.

2. Stop and waste-type control valves may not be installed underground.

3. All control valves and fixture stop valves installed in a water distribution system shall be accessible. Control valves for the individual plumbing fixtures and appliances within dwelling units shall be accessible from within the dwelling unit.

(f) *Water hammer arrestors.* All plumbing fixtures, appliances and appurtenances with 3/8 inch or larger inlet openings and with solenoid actuated quick closing valves shall be provided with water hammer arrestors. Water hammer arrestors shall be installed in the fixture supplies serving the fixtures, appliances or appurtenances. Water hammer arrestors shall be accessible.

(g) *Temperature control.* The water temperature to all showers in public buildings shall be controlled by thermostatic mixing valves or by individually controlled pressure balanced mixing valves.

(h) *Fittings and connections.* The drilling and tapping of water supply piping shall be prohibited except for:

1. Corporation cocks for a water service or a private water main; and

2. Self-tapping valves which serve individual plumbing appliances.

(i) *Flushing and disinfection of potable water supply systems.*

1. a. Before a newly constructed water supply system is to be put into use, the piping of the system shall be filled with water and allowed to stand for at least 24 hours. After 24 hours each water outlet shall be flushed beginning with the outlet closest to the building control valve and then each successive outlet in the system. The flushing at each water outlet shall continue for at least one minute and until the water appears clear at the outlet.

b. Each portion of a water supply system which is altered or repaired shall be flushed for at least one minute and until the water appears clear.

2. New private water mains and extensions to private water mains shall be disinfected prior to use in accordance with AWWA C601 or the following method:

a. The pipe system shall be flushed with clean water until no dirty water appears at the points of outlet.

b. The system or part thereof shall be filled with a solution of water and chlorine containing at least 50 parts per million of chlorine and the system or part thereof shall be valved off and allowed to stand for 24 hours or the system or part thereof shall be filled with a solution of water and chlorine containing at least 200 parts per million of chlorine and allowed to stand for 3 hours.

c. Following the allowed standing time, the system shall be flushed with clean potable water.

d. The procedures shall be repeated if it is shown by a bacteriological examination that contamination still exists in the system.

3. The department may require a water quality analysis to be done for a new or repaired water supply system. The analysis shall be performed in accordance with acceptable nationally recognized laboratory practices. If the water supply system has been disinfected, water samples for the analysis may not be taken sooner than 24 hours after disinfection.

Note: See s. Comm 84.30 (f) regarding the bending of pipe and protection from puncture.

(9) **PIPING BY PLUMBER.** In accordance with ch. 145, Stats., piping which conveys water for human use or consumption, or to plumbing fixtures and plumbing appliances of every description, shall be installed by persons licensed by the department.

(a) Private water mains and water services shall be installed by persons licensed by the department as a plumber or utility contractor.

(b) Water distribution piping shall be installed by persons licensed by the department as a plumber.

(c) Except for automatic fire sprinkler systems, piping or piping systems, which may include water heating or water treatment equipment, and which convey water not for human use or consumption from a water distribution system to water using equipment, are not required to be installed by persons licensed by the department.

(d) Where a pipe or piping system, which conveys water not for human use or consumption, connects to a water distribution system, that connection shall be provided with an approved means of backflow prevention in accordance with s. Comm 82.41. The means of backflow prevention shall be installed by persons licensed by the department as a plumber.

Page intentionally left blank.

Table 82.40-4
 MAXIMUM ALLOWABLE LOAD FOR COPPER TUBE—TYPE K, ASTM B88

Pressure Loss Due to Friction (in lbs. per 100 ft. of length)	Pipe Diameter (in inches)																											
	1/2"		3/4"		1"			1-1/4"			1-1/2"			2"			2-1/2"			3"			4"					
	G P M	WSFU		G P M	W SFU F M	G P M	WSFU		G P M	WSFU		G P M	WSFU		G P M	WSFU		G P M	WSFU		G P M	WSFU		G P M	WSFU			
		F M	FT				FM	FT		FM	FT		FM	FT		FM	FT		FM	FT		FM	FT		FM	FT		
0.5	—	—	0.5	—	3.0	—	3.0	5.0	—	6.0	9.0	—	12.0	18.0	6.0	27.0	31.0	15.0	57.0	51.0	50.0	132	110	300	425			
1	—	—	2.0	—	4.0	—	4.0	8.0	—	10.0	13.0	4.5	18.0	27.0	10.0	47.0	48.0	44.0	120	75.0	128	250	160	620	695			
2	0.5	—	0.5	3.0	—	6.4	—	8.0	12.0	4.0	17.0	18.0	6.0	27.0	39.0	26.0	83.0	70.0	108	225	110	300	425	230	1180			
3	1.0	—	1.0	4.0	—	8.0	—	10.0	15.0	5.0	22.0	23.0	7.5	38.0	50.0	48.0	128	85.0	170	300	140	485	580	280	1630			
4	1.5	—	1.5	4.0	—	9.0	—	12.0	17.0	5.5	25.0	27.0	10.0	47.0	56.0	65.0	154	100	245	375	160	620	695	NP				
5	2.0	—	2.0	5.0	—	11.0	4.0	15.0	19.0	6.0	28.5	31.0	15.0	57.0	65.0	90.0	200	115	335	450	NP							
6	2.0	—	2.0	5.5	—	12.0	4.0	17.0	21.0	7.0	32.0	34.0	19.0	67.0	70.0	108	225	NP										
7	2.5	—	2.5	6.0	—	13.0	4.5	18.0	23.0	7.5	38.0	37.0	23.0	77.0	73.0	120	240	NP										
8	2.5	—	2.5	6.5	—	14.0	4.5	20.0	25.0	8.5	43.0	40.0	27.0	87.0	NP													
9	3.0	—	3.0	7.0	—	15.0	5.0	22.0	27.0	10.0	47.0	42.0	30.0	100	NP													
10	3.0	—	3.0	7.5	—	16.0	5.0	23.0	28.0	11.0	50.0	NP																
11	3.0	—	3.0	7.5	—	17.0	5.5	25.0	30.0	14.0	55.0	NP																
12	3.5	—	3.5	8.0	—	18.0	6.0	27.0	NP																			
13	3.5	—	3.5	8.5	—	19.0	6.0	28.5	NP																			
14	3.5	—	3.5	9.0	—	20.0	6.5	30.0	NP																			
15	3.5	—	3.5	9.0	—	NP																						
16	3.5	—	3.5	9.5	—	NP																						
17	4.0	—	4.0	9.5	—	NP																						
18	4.0	—	4.0	10.0	4.0	NP																						
19	4.0	—	4.0	10.5	4.0	NP																						
20	4.0	—	4.0	11.0	4.0	NP																						
21	4.5	—	5.0	NP		NP																						
22	4.5	—	5.0	NP		NP																						
23	4.5	—	5.0	NP		NP																						
24	4.5	—	5.0	NP		NP																						
25	5.0	—	6.0	NP		NP																						
26	5.0	—	6.0	NP		NP																						
27	5.0	—	6.0	NP		NP																						
28	5.0	—	6.0	NP		NP																						
29	5.5	—	6.5	NP		NP																						
30	5.5	—	6.5	NP		NP																						
	NP		NP		NP			NP			NP			NP			NP			NP			NP			NP		

Notes: WSFU means water supply fixture units.
 GPM means gallons per minute.
 FM means predominately flushometer type water closets or syphon jet urinals.
 FT means predominately flush tank type water closets or washdown urinals.
 NP means not permitted, velocities exceed 8 feet per second.

For using this table, round the calculated pressure loss due to friction to the next higher number shown.

Comm 82.40 (7) (f) and (g) specifies minimum sizes for water distribution piping.

Table 82.40-5

MAXIMUM ALLOWABLE LOAD FOR COPPER TUBE—TYPE L, ASTM B88

Pressure Loss Due to Friction (in lbs. per 100 ft. of length)	Pipe Diameter (in inches)																										
	1/2"			3/4"			1"			1-1/4"			1-1/2"			2"			2-1/2"			3"			4"		
	G P M	WSFU		G P M	WSFU		G P M	WSFU		G P M	WSFU		G P M	WSFU		G P M	WSFU		G P M	WSFU		G P M	WSFU		G P M	WSFU	
FM		FT	FM		FT	FM		FT	FM		FT	FM		FT	FM		FT	FM		FT	FM		FT	FM		FT	FM
0.5	—	—	—	1.0	—	1.0	3.0	—	3.0	6.0	—	7.0	9.0	—	12.0	19.0	6.0	28.5	34.0	19.0	67.0	54.0	60.0	144	112	315	435
1	—	—	—	2.5	—	2.5	5.0	—	6.0	8.0	—	10.0	13.0	4.5	18.0	23.0	11.0	50.0	50.0	48.0	128	77.0	136	260	164	655	715
2	0.5	—	0.5	3.5	—	3.5	7.0	—	9.0	12.0	4.0	17.0	19.0	6.0	28.5	41.0	28.0	90.0	72.0	116	235	115	335	450	240	1540	
3	1.5	—	1.5	4.5	—	5.0	9.0	—	12.0	15.0	5.0	22.0	24.0	8.0	40.0	51.0	50.0	132	90.0	192	325	144	515	605	NP		
4	2.0	—	2.0	5.0	—	6.0	10.0	4.0	13.0	18.0	6.0	27.0	29.0	12.0	52.0	60.0	75.0	174	105	270	400	170	700	700	NP		
5	2.0	—	2.0	5.5	—	6.5	12.0	4.0	17.0	21.0	7.0	32.0	33.0	17.0	63.0	67.0	97.0	210	120	365	475	NP					
6	2.5	—	2.5	6.5	—	8.0	13.0	4.5	18.0	23.0	7.5	38.0	36.0	22.0	73.0	75.0	128	250	NP								
7	2.5	—	2.5	7.0	—	9.0	14.0	4.5	20.0	25.0	8.5	43.0	39.0	26.0	83.0	NP											
8	3.0	—	3.0	7.5	—	9.5	15.0	5.0	22.0	26.0	9.0	45.0	42.0	30.0	100	NP											
9	3.0	—	3.0	8.0	—	10.0	16.0	5.0	23.0	28.0	11.0	50.0	45.0	37.0	110	NP											
10	3.0	—	3.0	8.5	—	11.0	17.0	5.5	25.0	30.0	13.5	55.0	NP			NP											
11	3.5	—	3.5	9.0	—	12.0	18.0	6.0	27.0	32.0	16.0	60.0	NP			NP											
12	3.5	—	3.5	9.0	—	12.0	19.0	6.0	28.5	NP			NP														
13	3.5	—	3.5	9.5	—	12.5	20.0	6.5	30.0	NP			NP														
14	4.0	—	4.0	10.0	4.0	13.0	21.0	7.0	32.0	NP			NP														
15	4.0	—	4.0	10.5	4.0	14.0	NP				NP																
16	4.0	—	4.0	11.0	4.0	15.0	NP				NP																
17	4.5	—	5.0	11.5	4.0	16.0	NP				NP																
18	4.5	—	5.0	12.0	4.0	17.0	NP				NP																
19	4.5	—	5.0	12.0	4.0	17.0	NP				NP																
20	4.5	—	5.0	NP			NP																				
21	5.0	—	6.0	NP			NP																				
22	5.0	—	6.0	NP			NP																				
23	5.0	—	6.0	NP			NP																				
24	5.0	—	6.0	NP			NP																				
25	5.5	—	6.5	NP			NP																				
26	5.5	—	6.5	NP			NP																				
27	5.5	—	6.5	NP			NP																				
28	6.0	—	7.0	NP			NP																				
29	6.0	—	7.0	NP			NP																				

Notes: WSFU means water supply fixture units.
 GPM means—gallons per minute.
 FM means—predominately flushometer type water closets or syphon jet urinals.
 FT means—predominately flush tank type water closets or washdown urinals.
 NP means—not permitted, velocities exceed 8 feet per second.

For using this table, round the calculated pressure loss due to friction to the next higher number shown.
 Comm 82.40 (7) (f) and (g) specifies minimum sizes for water distribution piping.

Table 82.40-6

MAXIMUM ALLOWABLE LOAD FOR COPPER TUBE—TYPE M, ASTM B88

Pressure Loss Due to Friction (in lbs. per 100 ft. of length)	Pipe Diameter (in inches)																										
	1/2"			3/4"			1"			1-1/4"			1-1/2"			2"			2-1/2"			3"			4"		
	G P M	WSFU		G P M	WSFU		G P M	WSFU		G P M	WSFU		G P M	WSFU		G P M	WSFU		G P M	WSFU		G P M	WSFU		G P M	WSFU	
		FM	FT		FM	FT		FM	FT		FM	FT		FM	FT		FM	FT		FM	FT		FM	FT		FM	FT
0.5	—	—	—	1.5	—	1.5	3.5	—	3.5	6.0	—	7.0	9.5	—	12.5	20.0	6.5	30.0	34.0	19.0	67.0	56.0	65.0	154	110	334	450
1	—	—	—	3.0	—	3.0	6.0	—	6.0	9.0	—	12.0	14.0	4.5	20.0	29.0	12.0	52.0	50.0	48.0	128	80.0	148	275	160	700	750
2	1.0	—	1.0	4.0	—	4.0	7.5	—	9.5	13.0	4.5	18.0	20.0	6.5	30.0	42.0	30.0	100	75.0	128	250	120	365	475	250	1350	
3	1.5	—	1.5	5.0	—	6.0	9.5	—	12.5	16.0	5.0	23.0	25.0	8.5	42.0	52.0	53.0	136	93.0	205	340	150	555	640	280	1630	
4	2.0	—	2.0	5.5	—	6.5	11.0	4.0	15.0	19.0	6.0	28.5	30.0	13.5	55.0	62.0	80.0	184	110	300	425	175	740	780	NP		
5	2.5	—	2.5	6.5	—	8.0	12.5	4.5	17.5	22.0	7.0	35.0	34.0	19.0	67.0	70.0	108	225	120	365	475	NP					
6	2.5	—	2.5	7.0	—	9.0	14.0	4.5	20.0	24.0	8.0	40.0	37.0	23.0	77.0	77.0	136	260	NP								
7	3.0	—	3.0	7.5	—	9.5	15.0	5.0	22.0	26.0	9.0	45.0	40.0	27.0	87.0	80.0	148	275									
8	3.5	—	3.5	8.0	—	10.0	16.0	5.0	23.0	28.0	11.0	50.0	44.0	35.0	107	NP											
9	3.5	—	3.5	8.5	—	11.0	17.0	5.5	25.0	30.0	13.5	55.0	46.0	40.0	113												
10	3.5	—	3.5	9.5	—	12.5	18.0	6.0	27.0	31.0	15.0	57.0	NP														
11	4.0	—	4.0	10.0	4.0	13.0	19.0	6.0	28.0	32.0	16.0	60.0															
12	4.0	—	4.0	10.0	4.0	13.0	20.0	6.5	30.0	NP																	
13	4.0	—	4.0	10.5	4.0	14.0	21.0	7.0	32.0																		
14	4.5	—	5.0	11.0	4.0	15.0	NP																				
15	4.5	—	5.0	11.5	4.0	16.0																					
16	4.5	—	5.0	12.0	4.0	17.0																					
17	5.0	—	6.0	12.5	4.5	17.5																					
18	5.0	—	6.0	13.0	4.5	18.0																					
19	5.0	—	6.0	NP																							
20	5.5	—	6.5																								
21	5.5	—	6.5																								
22	5.5	—	6.5																								
23	5.5	—	6.5																								
24	6.0	—	7.0																								
25	6.0	—	7.0																								
26	6.0	—	7.0																								
27	6.0	—	7.0																								
28	6.5	—	8.0																								
	NP																										

Notes: WSFU means water supply fixture units.
 GPM means—gallons per minute.
 FM means—predominately flushometer type water closets or syphon jet urinals.
 FT means—predominately flush tank type water closets or washdown urinals.
 NP means—not permitted, velocities exceed 8 feet per second.
 For using this table, round the calculated pressure loss due to friction to the next higher number shown.
 Comm 82.40 (7) (f) and (g) specifies minimum sizes for water distribution piping.

Table 82.40-7
ALLOWABLE MAXIMUM LOAD FOR GALVANIZED STEEL PIPE, SCHEDULE 40
ASTM A53 and ASTM 120

Pressure Loss Due to Friction (in lbs. per 100 ft. of length)	Pipe Diameter (in inches)																										
	1/2"			3/4"			1"			1-1/4"			1-1/2"			2"			2-1/2"			3"			4"		
	G P M	WSFU		G P M	WSFU		G P M	WSFU		G P M	WSFU		G P M	WSFU		G P M	WSFU		G P M	WSFU		G P M	WSFU		G P M	WSFU	
		FM	FT		FM	FT		FM	FT		FM	FT		FM	FT		FM	FT		FM	FT		FM	FT		FM	FT
0.5	—	—	—	1.5	—	1.5	3.5	—	3.5	7.0	—	9.0	11.0	—	12.5	21.0	7.0	32.0	34.0	19.0	67.0	60.0	75.0	175	122	375	485
1	0.5	—	0.5	2.5	—	2.5	5.0	—	6.0	10.5	4.0	14.0	16.0	4.5	20.0	30.0	14.0	55.0	49.0	46.0	124	87.0	180	310	180	770	810
2	2.0	—	2.0	4.0	—	4.0	7.5	—	9.5	15.5	5.0	22.5	23.0	6.5	30.0	45.0	37.0	110	72.0	116	235	127	405	510	260	1440	
3	2.5	—	2.5	5.0	—	6.0	9.5	—	12.5	19.0	6.0	28.5	29.0	8.5	42.0	55.0	62.0	150	90.0	192	325	160	615	695	285	1660	
4	2.5	—	2.5	5.5	—	6.5	11.0	4.0	15.0	22.0	7.0	35.0	34.0	13.5	55.0	65.0	90.0	200	105	270	400	180	770	810	NP		
5	3.0	—	3.0	6.5	—	8.0	12.5	4.5	17.5	25.0	8.5	42.0	39.0	19.0	67.0	73.0	120	240	120	365	475	NP			NP		
6	3.5	—	3.5	7.5	—	9.5	14.0	4.5	20.0	28.0	11.0	50.0	43.0	23.0	77.0	81.0	152	280	NP			NP					
7	3.5	—	3.5	8.0	—	10.0	15.0	5.0	22.0	31.0	15.0	57.0	46.0	27.0	87.0	NP			NP								
8	4.0	—	4.0	8.5	—	11.0	16.0	5.0	23.0	33.0	17.0	63.0	50.0	35.0	107	NP			NP								
9	4.0	—	4.0	9.0	—	12.0	17.0	5.5	25.0	35.0	20.0	70.0	NP			NP											
10	4.5	—	5.0	9.5	—	12.5	18.0	6.0	27.0	37.0	23.0	77.0	NP			NP											
11	5.0	—	6.0	10.0	4.0	13.0	19.0	6.0	28.5	NP			NP														
12	5.0	—	6.0	10.5	4.0	14.0	20.0	6.5	30.0	NP			NP														
13	5.0	—	6.0	11.0	4.0	15.0	21.0	7.0	32.0	NP			NP														
14	5.5	—	6.5	11.5	4.0	16.0	NP			NP																	
15	6.0	—	7.0	12.0	4.0	17.0	NP			NP																	
16	6.0	—	7.0	12.5	4.5	17.5	NP			NP																	
17	6.0	—	7.0	13.0	4.5	18.0	NP			NP																	
18	6.0	—	7.0	13.5	4.5	19.0	NP			NP																	
19	6.5	—	8.0	NP			NP																				
20	6.5	—	8.0	NP			NP																				
21	7.0	—	9.0	NP			NP																				
22	7.0	—	9.0	NP			NP																				
23	7.0	—	9.0	NP			NP																				
24	7.5	—	9.5	NP			NP																				
25	7.5	—	9.5	NP			NP																				
	NP			NP			NP			NP			NP			NP			NP			NP			NP		

Notes: WSFU means water supply fixture units.
 GPM means gallons per minute.
 FM means predominately flushometer type water closets or syphon jet urinals.
 FT means predominately flush tank type water closets or washdown urinals.
 NP means not permitted, velocities exceed 8 feet per second.
 For using this table, round the calculated pressure loss due to friction to the next higher number shown.
 Comm 82.40 (7) (f) and (g) specifies minimum sizes for water distribution piping.

Table 82.40-8
MAXIMUM ALLOWABLE LOAD FOR POLYBUTYLENE TUBING—ASTM D3309 and
CHLORINATED POLYVINYL CHLORIDE TUBING—ASTM D2846

Pressure Loss Due to Friction (in lbs. per 100 ft. of length)	Pipe Diameter (in inches)																	
	1/2"			3/4"			1"			1-1/4"			1-1/2"			2"		
	G P M	WSFU		G P M	WSFU		G P M	WSFU		G P M	WSFU		G P M	WSFU		G P M	WSFU	
		FM	FT		FM	FT		FM	FT		FM	FT		FM	FT		FM	FT
0.5	—	—	—	0.5	—	0.5	2.5	—	2.5	4.0	—	4.0	6.5	—	8.0	13.0	4.5	18.0
1	—	—	—	1.5	—	1.5	3.5	—	3.5	6.0	—	7.0	9.5	—	12.5	19.0	6.0	28.5
2	—	—	—	2.5	—	2.5	5.5	—	6.5	9.0	—	12.0	14.0	4.5	20.0	28.0	11.0	50.0
3	0.5	—	0.5	3.5	—	3.5	6.5	—	8.0	11.5	4.0	15.0	17.0	5.5	25.0	35.0	20.0	70.0
4	1.0	—	1.0	4.0	—	4.0	7.5	—	9.5	13.0	4.5	18.0	20.0	6.5	30.0	42.0	30.0	100
5	1.5	—	1.5	4.5	—	5.0	8.5	—	11.0	15.0	5.0	22.0	23.0	7.5	37.0	47.0	42.0	117
6	2.0	—	2.0	5.0	—	6.0	9.5	—	12.5	16.5	5.5	24.0	25.0	8.5	43.0	52.0	53.0	136
7	2.0	—	2.0	5.5	—	6.5	10.5	—	14.0	18.0	6.0	27.0	27.0	10.0	48.0	58.0	70.0	165
8	2.0	—	2.0	6.0	—	7.0	11.5	4.0	16.0	19.0	6.0	28.5	30.0	14.0	55.0	NP		
9	2.5	—	2.5	6.0	—	7.0	12.0	4.0	17.0	20.5	6.5	31.0	32.0	16.0	60.0	NP		
10	2.5	—	2.5	6.5	—	8.0	12.5	4.5	17.5	22.0	5.0	35.0	34.0	19.0	67.0	NP		
11	2.5	—	2.5	7.0	—	9.0	13.5	4.5	19.0	23.0	6.0	38.0	NP			NP		
12	3.0	—	3.0	7.0	—	9.5	14.0	4.5	20.0	24.0	7.0	40.0	NP			NP		
13	3.0	—	3.0	7.5	—	10.0	14.5	4.5	21.0	NP			NP			NP		
14	3.0	—	3.0	8.0	—	10.0	15.5	5.0	22.0	NP			NP			NP		
15	3.0	—	3.0	8.0	—	11.0	16.0	5.0	23.0	NP			NP			NP		
16	3.5	—	3.5	8.5	—	11.0	16.5	5.5	24.0	NP			NP			NP		
17	3.5	—	3.5	8.5	—	12.0	NP			NP			NP			NP		
18	3.5	—	3.5	9.0	—	12.0	NP			NP			NP			NP		
19	3.5	—	3.5	9.0	—	12.0	NP			NP			NP			NP		
20	4.0	—	4.0	9.5	—	12.5	NP			NP			NP			NP		
21	4.0	—	4.0	10.0	4.0	13.0	NP			NP			NP			NP		
22	4.0	—	4.0	NP			NP			NP			NP			NP		
23	4.0	—	4.0	NP			NP			NP			NP			NP		
24	4.0	—	4.0	NP			NP			NP			NP			NP		
25	4.0	—	4.0	NP			NP			NP			NP			NP		
26	4.0	—	4.0	NP			NP			NP			NP			NP		
27	4.5	—	5.0	NP			NP			NP			NP			NP		
28	4.5	—	5.0	NP			NP			NP			NP			NP		
29	4.5	—	5.0	NP			NP			NP			NP			NP		
30	5.0	—	6.0	NP			NP			NP			NP			NP		
31	5.0	—	6.0	NP			NP			NP			NP			NP		

Note: WSFU means water supply fixture units.
 GM means gallons per minute.
 FM means predominately flushometer type water closets or syphon jet urinals.
 FT means predominately flush tank type water closets or washdown urinals.
 NP means not permitted, velocities exceed 8 feet per second.

For using this table, round the calculated pressure loss due to friction to the next higher number shown.

Comm 82.40 (7) (f) and (g) specifies minimum sizes for water distribution piping.

Table 82.40-9
MAXIMUM ALLOWABLE LOAD FOR CROSSLINKED POLYETHYLENE (PEX) TUBING
 ASTM F876 and F877

Pressure Loss Due to Friction (in lbs per 100 ft. of length)	Pipe Diameter (in inches)					
	1/2"		5/8"		3/4"	
	GPM	WSFU	GPM	WSFU	GPM	WSFU
		FT		FT		FT
0.5	0.5	0.5	1.0	1.0	1.5	1.5
1.0	0.5	0.5	1.5	1.5	2.0	2.0
2.0	1.0	1.0	2.0	2.0	3.0	3.0
3.0	1.5	1.5	2.5	2.5	3.5	3.5
4.0	1.5	1.5	2.5	2.5	4.0	4.0
5.0	2.0	2.0	3.0	3.0	4.5	5.0
6.0	2.0	2.0	3.5	3.5	5.0	6.0
7.0	2.0	2.0	4.0	4.0	5.5	6.0
8.0	2.5	2.5	4.0	4.0	6.0	7.0
9.0	2.5	2.5	4.5	5.0	6.5	8.0
10.0	2.5	2.5	4.5	5.0	7.0	9.0
11.0	3.0	3.0	5.0	6.0	7.5	9.5
12.0	3.0	3.0	5.0	6.0	7.5	9.5
13.0	3.0	3.0	5.5	6.5	8.0	10.0
14.0	3.0	3.0	5.5	6.5	8.5	11.0
15.0	3.5	3.5	5.5	6.5	8.5	11.0
16.0	3.5	3.5	6.0	7.0	9.0	12.0
17.0	3.5	3.5	6.0	7.0	NP	
18.0	3.5	3.5	6.5	8.0	NP	
19.0	4.0	4.0	6.5	8.0		
20.0	4.0	4.0	NP			
21.0	4.0	4.0	NP			
22.0	4.0	4.0	NP			
23.0	4.0	4.0	NP			
24.0	4.5	5.0	NP			
25.0	4.5	5.0	NP			
26.0	NP		NP		NP	

Note: WSFU means—water supply fixture units.
 GPM means—gallons per minute.
 FT means—predominately flush tank type water closets
 or washdown urinals.
 NP means—not permitted, velocities exceed eight feet
 per second.
 For using this table, round the calculated pressure loss due to
 friction to the next higher number shown.
 Comm 82.40 (7) (f) and (g) specifies minimum sizes for water
 distribution piping.

History: 1-2-56: r. and recr. Register, November, 1972, No. 203, eff. 12-1-72; r. and recr. Register, February, 1979, No. 278, eff. 3-1-79; renum. from H 62.13, Register, July, 1983, No. 331, eff. 8-1-83; renum. from ILHR 82.13 and r. and recr. (2) (b) and (4) (d) 1., am. (4) (c) 3. and (6) (a) (Intro.), cr. (6) (b). Register, February, 1985, No. 350, eff. 3-1-85; r. and recr. Register, May, 1988, No. 389, eff. 6-1-88; am. (5) (d) 5. a., r. and recr. (7) (h) 1. and (8) (c), renum. (8) (c) 2. to 6. to be (8) (b) 4. to 8. and am. (8) (b) 4. c., Register, August, 1991, No. 428, eff. 9-1-91; am. (8) (b) 1. and 2., Register, April, 1992, No. 436, eff. 5-1-92; renum. (3) (c) and (8) (a) to be (3) (c) 2. and (8) (a) 1. and am. (8) (a) 1., cr. (3) (c) 1., (e), (8) (a) 2. and Table 82.40-9, am. (7) (c), r. (3) (b) 1. b. and c., Register, February, 1994, No. 458, eff. 3-1-94; r. (5) (b) 3., renum. (5) (b) 4., 5. to be (5) (b) 3., 4., Register, December, 1996, No. 480, eff. 4-1-96; correction in (5) (b) 3., made under s. 13.93 (2m) (b) 7., Stats., Register, October, 1996, No. 490; r. and recr. (5) (b), Register, February, 1997, No. 494, eff. 4-1-97.

Comm 82.41 Cross connection control. (1) SCOPE. The provisions of this section set forth the requirements for the protection of potable water within water supply systems when and where there is the possibility of contamination due to cross connections or backflow conditions.

Note: The Department of Natural Resources governs the operation and design of community water systems and under s. NR 811.09 requires the supplier of water to develop and implement a comprehensive cross connection control program.

(2) MATERIALS. (a) All devices, assemblies and mechanisms intended to protect potable water supplies relative to cross connection or backflow shall be of a type recognized and approved in accordance with ch. Comm 84 and as described in sub. (4).

(b) All methods including barometric loops and air gaps intended to protect potable water supplies relative to cross connection or backflow shall be constructed of materials suitable for water supply systems in accordance with ch. Comm 84.

(3) GENERAL REQUIREMENTS. Potable water supply systems and the connection of each plumbing fixture, piece of equipment, appliance, or nonpotable water piping system thereto shall be designed, installed and maintained in such a manner to prevent the contamination of potable water supplies by means of cross connections.

(a) Types of cross connection control. 1. Potable water supply systems shall be protected against contamination due to cross connections or backflow conditions by one of the methods or devices specified in Table 82.41-1 depending upon the situation or Table 82.41-2 depending upon the specific application or use, and the limitations specified in sub. (4).

2. For the situations described in par. (b) 3., cross connection control shall be provided as part of the fixture outlet or in the water supply piping for the fixture outlet.

Table 82.41-1

ACCEPTABLE CROSS CONNECTION CONTROL METHODS

TYPES or METHODS of CROSS CONNECTION CONTROL	SITUATIONS and CONDITIONS							
	Backpressure				Backsiphonage			
	Low Hazard		High Hazard		Low Hazard		High Hazard	
	Continual Pressure	Noncontinual Pressure	Continual Pressure	Noncontinual Pressure	Continual Pressure	Noncontinual Pressure	Continual Pressure	Noncontinual Pressure
Air Gaps (ANSI A112.1.2)	X	X	X	X	X	X	X	X
Pipe Applied Atmospheric Type Vacuum Breakers (ASSE 1001)						X		X
Hose Connection Backflow Preventers (ASSE 1052)	X ^a	X	X ^a	X	X ^a	X	X ^a	X
Hose Connection Vacuum Breakers (ASSE 1011)	X ^a	X	X ^a	X	X ^a	X	X ^a	X
Backflow Preventers with Intermediate Atmospheric Vent (ASSE 1012)	X	X			X	X		
Reduced Pressure Principle Backflow Preventers (ASSE 1013)	X	X	X	X	X	X	X	X
Pressure vacuum breaker assembly (ASSE 1020)					X	X	X	X
Back siphonage backflow vacuum breaker (ASSE 1056)					X	X	X	X
Barometric Loops					X	X	X	X

^a See limitation under sub. (4) (c) 1.a.

Table 82.41-2

ACCEPTABLE CROSS CONNECTION CONTROL METHODS FOR SPECIFIC APPLICATIONS

Types or Methods of Cross Connection Control	Types of Application or Use
Water Closet Flush Tank Ball Cocks (ASSE 1002)	Gravity water closet flush tanks
Hand Held Showers (ASSE 1014)	Hand held shower assemblies
Double Check Backflow Prevention Assemblies (ASSE 1015)	Automatic fire sprinkler systems and Standpipe systems
Trap Seal Primer Valves, Water Supply Fed (ASSE 1018)	Traps for drain systems
Vacuum Breaker Wall Hydrant, Freeze Resistant Automatic Draining Type (ASSE 1019)	Hose threaded outlet connections
Backflow Preventer for Carbonated Beverage Machines (ASSE 1022)	Carbonated beverage dispensers, post mix types
Laboratory Backflow Preventers (ASSE 1035)	Laboratory faucets
Pressurized Flushing Devices (Flushometers) for Plumbing Fixtures (ASSE 1037)	Flushometer plumbing fixtures
Reduced Pressure Detector Backflow Preventer (ASSE 1047)	Automatic fire sprinkler systems
Double Check Detector Assembly Backflow Preventer (ASSE 1048)	Automatic fire sprinkler systems and Standpipe systems
Vacuum Breaker Tees [sub. (5) (k)]	Water treatment devices

(b) *Classifications.* For the purposes of this section:

1. The designation of a high hazard or low hazard situation shall be determined on the basis of how a toxic or nontoxic solution is intended or recommended by the manufacturer of the solution to interface with the potable water supply system.

2. a. A continuous pressure situation shall be considered to exist when a pressure greater than atmospheric within the water supply system exists for more than 12 continuous hours.

b. A noncontinuous pressure situation shall be considered to exist if the conditions in subd. 2. a. do not occur.

3. A high hazard cross connection situation shall be considered to exist for a connection of the water supply system to:

a. Any part of the drain system; and

b. Any other piping system conveying water from nonpotable sources, including but not limited to lakes, rivers, streams or creeks.

4. Except as provided in subd. 5., a high hazard cross connection situation shall be considered to exist at:

a. A water supply hose bibb, faucet, wall hydrant, sill cock or other outlet which terminates with hose threads allowing a hose to be attached;

b. A water supply faucet, wall hydrant or other outlet which terminates with a serrated nipple allowing a hose to be attached; and

c. A water supply faucet, hydrant or outlet serving a sink used for building maintenance in a public building.

5. A cross connection shall not be considered to exist at the hose threaded outlet installed for the sole purpose of:

a. Draining a water supply system or any portion thereof;

b. Obtaining water quality samples of the water supply system or any portion thereof; or

c. Connecting individual residential automatic clothes washers.

6. a. A high hazard situation shall be considered to exist for the connection of two water supply systems one supplied by a public water supply and the other system supplied by a private well.

Note: The interconnection of a public water supply system and another source of water is addressed in s. NR 811.09 and must be approved by the Department of Natural Resources.

b. Except as provided in subd. 7., a low hazard situation shall be considered to exist for the connection of a piping system, including but not limited to automatic fire sprinkler systems, standpipe systems, and processing purposes, which provides potable water for nonrequired potable water uses.

Note: Cross connection control devices used in conjunction with automatic fire sprinkler systems are to be listed by an acceptable testing agency for such an application under the standards governing the design and installation of automatic fire sprinkler systems.

7. A cross connection situation shall not be considered to exist for an automatic fire sprinkler system serving a one- or 2- family dwelling provided the sprinkler system is constructed of materials and joints suitable for water distribution systems as specified in ss. Comm 84.30 (4) (e) and 84.40, respectively and the sprinkler system is supplied with only potable water.

(c) *Containment.* 1. For sewerage treatment facilities which are required to conform with ch. NR 110, in addition to the cross connection control required for each potable water usage or water outlet, a reduced pressure principle backflow preventer shall be installed:

a. In the water service to each building or structure within the complex;

b. In the private water main upstream of all water services serving the facility; or

c. In the water distribution system upstream of all water outlets and in the process piping network upstream of all points of use, if both a water distribution system and a process network is contained within the same building or structure.

2. For marinas, wharves and docks where potable water outlets are provided to serve boats or ships, in addition to the cross connection control required for each potable water outlet or usage, a reduced pressure principle backflow preventer shall be installed in the water supply system to limit backflow into the water supply source.

3. The installation of a cross connection control device in the water supply system for a building or structure shall not alleviate the requirement to provide cross connection control for the connection of each plumbing fixture, piece of equipment, appliance or other piping system.

(d) *Prohibitions.* The use of a toxic solution as a heat transfer fluid in single-wall heat exchanger for potable water is prohibited.

(e) *Existing automatic fire sprinkler systems.* An alteration, modification or addition to an existing automatic fire sprinkler shall necessitate conformance with this section, if the:

1. Existing water supply line to the existing sprinkler system is increased in diameter; or

2. Existing device or method which had been previously recognized to address cross connection concerns is to be removed or replaced.

(4) LIMITATIONS. (a) Cross connection control devices shall be limited in use in accordance with the respective standard, unless otherwise specifically permitted under this subsection.

(b) A pipe applied atmospheric type vacuum breaker shall be installed such that the bottom of the device or the critical level mark on the device is at least 6 inches above:

1. The flood level rim of the receptor serving the water supply port; and

2. The highest point downstream from the device where backpressure would be created.

(c) 1. a. The use of a hose connection backflow preventer and a hose connection vacuum breaker in a continuous pressure situation shall be limited to campgrounds and marinas.

b. The use of a hose connection backflow preventer and a hose connection vacuum breaker shall be limited to the discharge side of a control valve such as a faucet or hose bibb.

2. A hose connection backflow preventer and a hose connection vacuum breaker may not be employed in backpressure situations of more than 10 feet of water column.

(d) A backflow preventer with intermediate atmospheric vent:

1. May not be employed in backpressure situations of more than 150 psig; and

2. May not serve boilers having a maximum steam pressure setting greater than 15 psig or a maximum water pressure setting greater than 30 psig.

(e) 1. A reduced pressure principle backflow preventer and a reduced pressure detector backflow preventer may not be subjected to a backpressure greater than twice the rated working pressure of the device.

2. A reduced pressure principle backflow preventer and a reduced pressure detector backflow preventer which serve a water-based fire protection system may have a test outlet located between the number 2 check valve and the number 2 listed indicating control valve.

3. A reduced pressure principle backflow preventer and a reduced pressure detector backflow preventer which are 2 inches or smaller in size and which serve a water-based fire protection system are not required to have a test cock on the number one listed indicating control valve.

(f) A hand-held shower may not be employed in backpressure situations of more than 2 feet of water column.

(g) 1. A double check backflow prevention assembly and a double check detector assembly backflow preventer may not be subjected to a backpressure greater than twice the rated working pressure of the device.

2. A double check backflow prevention assembly and a double check detector assembly backflow preventer which serve a water-based fire protection system may have a test outlet located between the number 2 check valve and the number 2 listed indicating control valve.

Note: See Appendix for further explanatory material.

3. A double check backflow prevention assembly and a double check detector assembly backflow preventer which are 2 inches or smaller in size and which serve a water-based fire protection system are not required to have a test cock on the number one listed indicating control valve.

(h) A water supply fed trap seal primer valve shall be installed such that the bottom of the device or the critical level as marked on the device is at least 12 inches above:

1. The connection to the trap; and

2. The highest point downstream from the device where backpressure would be created.

(i) A vacuum breaker wall hydrant, freeze resistant automatic draining type, may not be employed in backpressure situations of more than 10 feet of water column.

(k) 1. A pressure vacuum breaker assembly shall be installed such that the bottom of the device or the critical level mark on the device is at least 12 inches above:

a. The flood level rim of the receptor serving the water supply port; and

b. The highest point downstream from the device where backpressure would be created.

2. A pressure vacuum breaker assembly shall be located only outside.

(l) A laboratory faucet backflow preventer may not be employed in backpressure situations of more than 6 feet of water column.

(m) The cross connection control device to serve a hose bibb or hydrant that penetrates an exterior wall of a heated structure may not prevent a hose bibb or hydrant from being freeze resistant automatic draining as required under s. Comm 82.40 (8) (a).

(n) A back siphonage backflow vacuum breaker shall be installed so that the bottom of the device or the critical level mark on the device is at least 12 inches above:

a. The flood level rim of the receptor serving the water supply port; and

b. The highest point downstream from the device where backpressure would be created.

(5) INSTALLATION. (a) An air gap for cross connection control shall conform to ANSI A112.1.2.

Note: See Appendix for further explanatory material.

(b) Cross connection control methods, devices and assemblies shall be installed in accordance with the manufacturer's written installation specifications and this chapter. The methods, devices and assemblies shall be accessible for inspection, testing, maintenance and replacement.

Note: See s. Comm 84.30 (5) (c).

(c) Cross connection control devices shall be protected from freezing.

(d) 1. A cross connection control device may not be located in uninhabitable spaces susceptible to flooding.

2. A cross connection control device which has one or more vent ports may not be located in a pit, vault or depression which is below the adjacent grade or floor level, even if the pit, vault or depression is provided with a drain at the bottom of the pit.

(e) 1. Vent ports of cross connection control devices shall be positioned:

a. Away from areas where toxic gases and fumes may accumulate;

b. Downward or protected to protect the ports from falling debris; and

c. So as to drain dry.

2. Cross connection control devices shall be so located that any vent ports of the devices shall be provided with an air gap in accordance with par. (a).

3. a. If a reduced pressure principle backflow preventer or a reduced pressure detector backflow preventer is located within a building, a drain or receptor shall be provided to receive the discharge from the vent ports of the device. If a floor drain is to receive the discharge from the vent ports of a reduced pressure principle backflow preventer or a reduced pressure detector backflow preventer, the flow or pathway of the discharge may not create a nuisance.

b. Where drain piping is provided for the discharge from a vent port, an air gap in accordance with par. (a) shall be provided between the vent port and the drain piping.

c. Where a receptor is provided for the discharge from a vent port, an air gap in accordance with par. (a) shall be provided between the vent port and the receptor.

(f) The installation of a reduced pressure principle backflow preventer, a reduced pressure detector backflow preventer, a double check backflow prevention assembly, a double check

detector assembly backflow preventer, a pressure vacuum breaker assembly and a back siphonage backflow vacuum breaker shall conform to the following limitations:

1. The minimum distance between the floor, surface or platform which is to provide access and the lowest point of the assembly may not be less than 12 inches.
2. The maximum distance between the floor, surface or platform which is to provide access and the lowest point of the assembly may not be more than 7 feet.
3. The minimum distance between a ceiling or other obstruction and the highest point of the assembly may not be less than 18 inches.
4. The minimum distance between a wall or other obstruction and the back and ends of the assembly may not be less than 4 inches.
5. The minimum distance between a wall or other obstruction and the front of the assembly may not be less than 24 inches.

Note: See Appendix for further explanatory material.

(g) The discharge outlet of local waste piping serving a cross connection control device shall be visible and not be located within a concealed space.

(i) No control valve may be placed downstream from a pipe applied atmospheric type vacuum breaker or a laboratory faucet backflow preventer.

(j) A barometric loop to provide cross connection control for backsiphonage shall be formed by creating a loop in the potable water supply piping upstream to the source of cross connection.

1. The loop shall extend at least 35 feet above:
 - a. The highest point downstream from the loop where back-pressure would be created; and
 - b. The point of discharge.
2. No outlets for potable water use shall be installed downstream of the peak of the loop.

(k) Vacuum breaker tees shall be assembled such that:

1. The bottom of the horizontal portion of the tee is installed at least one inch above the flood level rim of the receptor;
2. The inside diameter of the tee is equal to or greater than the inside diameter of the drain piping from the water treatment device;
3. The tee is installed in such a position that the discharge will not create a nuisance;
4. The piping upstream of the tee is of a type suitable for water distribution in accordance with s. Comm 84.30 (4) (c).
5. The vent portion of the tee is equal to or greater than the inside diameter of the drain piping from the water treatment device; and
6. The vent port of the tee is:
 - a. Positioned away from areas where toxic gases and fumes may accumulate; and
 - b. Constructed to protect the port from falling debris.

(6) MAINTENANCE AND TESTING. (a) All cross connection control devices shall be maintained and tested in accordance with s. Comm 82.21 (3).

History: 1-2-56; r. (2) through (7), Register, October, 1971, No. 190, eff. 11-1-71; r. and recr. Register, November, 1972, No. 203, eff. 12-1-72; renum. from H 62.14, Register, July, 1983, No. 331, eff. 8-1-83; renum. from LHR 82.14 and am. (1) (h) 17., r. (2), Register, February, 1985, No. 350, eff. 3-1-85; r. and recr. Register, February, 1994, No. 458, eff. 3-1-94; am. (2) (a), Tables 82.41-1, 2, (4) (c), (e) to (h), (k) to (m), (5) (e) 3. a., (i), cr. (4) (n), r. and recr. (5) (b), (f), r. (5) (h), Register, February, 1997, No. 494, eff. 3-1-97.

Subchapter V— Special Plumbing Installations

Comm 82.50 Health care and related facilities.

(1) PLAN APPROVAL REQUIRED. Plans for plumbing and equipment for health care facilities shall be approved by the department.

(2) SCOPE. The scope of this section shall cover devices, fixtures and equipment which are installed and maintained in health

care facilities such as hospitals, nursing or rest homes, homes for the aged, infirmaries, residential care facilities, orphanages, sanitariums, sanatoriums, clinics, mortuaries, and schools of medicine, surgery, dentistry, and research and testing laboratories whether enumerated or not. This section may also apply to offices of dentists and doctors.

(3) INTENT. The primary intent of the following minimum requirements is to protect public health by eliminating either potential health or safety hazards to patients and institutional personnel, and to promote the efficient use, operation and maintenance of the equipment used in the institution or establishment. Fixtures, devices and/or equipment in addition to those prescribed herein may be required dependent upon the type of occupancy, treatment, care or layout. Such additional facilities shall be installed in accord with the provisions of this chapter.

(4) PLUMBING IN MENTAL HOSPITALS. Special consideration shall be given to the design and installation of plumbing fixtures in areas where disturbed patients are housed. No pipes or traps shall be exposed and all fixtures shall be securely bolted through walls or floors.

(5) SPECIAL FIXTURES AND EQUIPMENT ACCEPTABILITY. (a) *Special fixtures.* Fixtures which are designed for any special use such as, therapy, special cleansing and/or disposal of waste materials shall be smooth, impervious, corrosion resistant materials and, if subject to temperatures in excess of 180°F, shall be able to withstand without damage, higher temperatures as may be specified. Scrub-up sinks, lavatories and sinks in patient care areas, and fixtures used by medical and nursing staff, shall have the water supply spout terminate a minimum of 5 inches above the rim of the fixture. These fixtures shall be equipped with valves or faucets which can be operated without use of the hands.

(b) *Special equipment.* All devices, appurtenances, appliances and apparatus intended to serve a special function such as sterilization, distillation, processing, cooling, storage of ice or foods, etc., which may be connected to either the water supply distribution or drainage systems or both, shall be provided with protection against back-siphonage, backflow, flooding, fouling, or any possibility of contaminating any portion of the water supply system, or equipment, or the misuse of any drain.

(c) *Therapeutic equipment.* Therapeutic equipment shall not be counted as a patient bathing fixture to meet the required patient bath ratio.

(6) FIXTURE AND EQUIPMENT INSTALLATION. (a) *Clinic sinks.* Such fixtures shall have an integral trap in which the upper portion of a visible trap seal provides a water surface. The fixture shall be designed so as to permit complete removal of the contents by siphonic and/or blow-out action, and to reseal the trap in a single flushing operation. A flushing rim shall provide water to cleanse the interior surface. The fixtures shall have flushing and cleansing characteristics similar to a water closet.

(b) *Prohibited use of clinic sinks and service sinks.* A clinic sink shall not be used as a janitor's service sink. A janitor's service sink shall not be used for the disposal of urine, fecal matter, or other human wastes.

(c) *Special requirement for ice manufacture and storage.* 1. No machines for manufacturing ice, or any device for handling or storing ice, shall be located in a room containing a bedpan hopper, clinic sink, bedpan washer, or similar fixture. Machines for manufacturing ice, or devices for handling or storing ice intended for either human consumption or packs, shall be located in a clean utility room, a floor pantry, a diet kitchen, or in other similar locations.

2. Each drain serving an ice chest or box shall discharge into an indirect waste receptor. Each drain shall discharge through an air-break above the receptor. The end of the drain shall be covered with a removable 10 mesh per inch noncorrosive screen.

(7) STERILIZERS. (a) *Descaling prohibited.* The interior of water sterilizers, stills, or similar equipment shall not be descaled

or otherwise treated by acid or other chemical solutions while the equipment is connected to the water and/or drainage systems.

(b) *Compliance with boiler and pressure vessel code.* Pressure sterilizers and pressure type instrument washer sterilizers installed after the effective date of this code shall be constructed and stamped in accordance with the provisions of chs. ILHR 41 and 42. All pressure sterilizers and pressure type instrument washer sterilizers regardless of size shall be equipped with pressure relief devices in accordance with the provisions of chs. ILHR 41 and 42.

(c) *Sterilizer piping.* The connecting piping and/or devices for sterilizers shall be accessible for inspection and maintenance.

(d) *Bedpan washers and clinic sinks.* Bedpan washers and clinic sinks shall be connected to the sanitary drainage system and vented in accordance with the requirements for water closets. Vapor vents serving bedpan washers shall not connect to the plumbing system.

(8) **DRAINAGE AND VENTING.** (a) *Sterilizer wastes.* 1. Indirect wastes required. All sterilizers shall be provided with individual and separate indirect wastes, with air-gaps of not less than 2 diameters of the waste tailpiece. The upper rim of the receptor, funnel, or basket type waste fitting shall be not less than 2 inches below the vessel or piping, whichever is lower. Except as provided in subds. 3. and 5., a "P" trap shall be installed on the discharge side of and immediately below the indirect waste connection serving each sterilizer.

2. Floor drain required. In any room containing the recessed, or concealed portions of sterilizers, not less than one acceptable floor drain, connecting to the drainage system, shall be installed in a manner to drain the entire floor area. The floor drain waste and trap shall be a minimum diameter of 3 inches. It shall receive the drainage from at least one sterilizer within the room to assure maintenance of the floor drain trap seal. The sterilizer drain may be installed on a branch taken off between the floor drain trap and the strainer. No individual sterilizer waste trap shall be required on this type of installation. See following sketch.

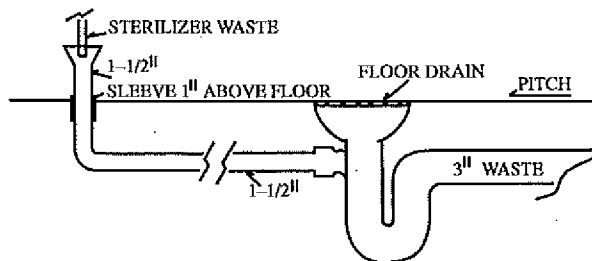

3. Battery assemblies. A battery assembly of not more than 3 sterilizer wastes may drain to one trap, provided the trap and waste are sized according to the combined fixture unit rating; the trap is located immediately below one of the indirect waste connections; the developed distance of a branch does not exceed 8 feet; and the branches change direction through a tee-wye or wye pattern fitting.

4. Bedpan steamers, additional trap required. A trap with a minimum seal of 3 inches shall be provided in a bedpan steamer drain located between the fixture and the indirect waste connection.

5. Pressure sterilizer. Except when an exhaust condenser is used, a pressure sterilizer chamber drain may be connected to the exhaust drip tube before terminating at the indirect waste connection. If a vapor trap is used, it shall be designed and installed to prevent moisture being aspirated into the sterilizer chamber. The jacket steam condensate return, if not connected to a gravity steam condensate return, shall be separately and indirectly wasted. If necessary to cool a high temperature discharge, a cooling receiver, trapped on its discharge side, may serve as the fixture trap.

6. Pressure sterilizer exhaust condensers. The drain from the condenser shall be installed with an indirect waste. If condensers are used on pressure sterilizers, the chamber drain shall have a separate indirect waste connection.

7. Water sterilizer. All water sterilizer drains, including tank, valve leakage, condenser, filter and cooling, shall be installed with indirect waste or according to subd. 2.

8. Pressure instrument washer-sterilizer. The pressure instrument washer-sterilizer chamber drain and overflow may be interconnected. Also, they may be interconnected with the condenser.

(b) *Vapor vent material.* Material for vapor vents serving bedpan washers and sterilizer vents serving sterilizers shall be materials approved for vent piping.

(c) *Vent connections prohibited.* Connections between vapor vents serving bedpan washers; sterilizing apparatus, and/or normal sanitary plumbing systems, are prohibited.

(d) *Vapor vents and stacks.* 1. Bedpan washers shall be vented to the outer atmosphere above the roof by means of one or more vapor vents. The vapor vent for a bedpan washer shall be not less than a 2-inch diameter pipe. A vapor vent serving a single bedpan washer may drain to the fixture served.

2. Multiple installations. Where bedpan washers are located above each other on more than one floor, a vapor vent stack may be installed to receive the vapor vent on the various floors. Not more than 3 bedpan washers shall be connected to a 2-inch vapor vent stack, 6 to a 3-inch vapor vent stack, and 12 to a 4-inch vapor vent stack. In multiple installations, the connections between a bedpan washer vapor vent and a vapor vent stack shall be made by use of a tee or tee-wye sanitary pattern drainage fittings, installed in an upright position.

3. Trap required. The bottom of the vapor vent stack, except when serving only one bedpan washer, shall be drained by means of a trapped and vented waste connection to the plumbing sanitary drainage system. The trap and waste shall be the same size as the vapor vent stack.

4. Trap seal maintenance. A water supply of not less than 1/4 inch minimum tubing shall be taken from the flush supply of each bedpan washer on the discharge or fixture side of the vacuum breaker, trapped to form not less than a 3-inch seal, and connected to the vapor vent stack on each floor. The water supply shall be so installed as to provide a supply of water to the vapor vent stack for cleansing and drain trap seal maintenance each time a bedpan washer is flushed.

(c) *Sterilizer vapor vent and stacks.* 1. Connections. Multiple installations of pressure and nonpressure sterilizers shall have their vent connections to the sterilizer vent stack made by means of inverted wye fittings. Such vent connections shall be accessible for inspection and maintenance.

2. Drainage. The connection between sterilizer vent and/or exhaust openings and the sterilizer vent stack shall be designed and installed to drain to the funnel or basket-type waste fitting. In multiple installations, the sterilizer vent stack shall be drained separately to the lowest sterilizer funnel or basket-type waste fitting or receptor.

(f) *Sterilizer vapor vent stack sizes.* 1. Bedpan steamers. The minimum size of a sterilizer vent serving a bedpan steamer shall be 1-1/2 inches in diameter. Multiple installation shall be sized according to Table 22.

2. Boiling type sterilizers. The minimum size of a sterilizer vent stack shall be 2 inches in diameter when serving a utensil sterilizer, and 1-1/2 inches in diameter when serving an instrument sterilizer. Combinations of boiling type sterilizer vent connections shall be based on Table 22.

Table 22
VAPOR VENT STACK SIZES FOR BEDPAN STEAMERS AND BOILING TYPE STERILIZERS
 (Number of connections of various sizes permitted to various sized sterilizer vent stacks)

Stack size	Connection size	
	1½"	2"
1½-inch ¹	1 or	0
2-inch ¹	2 or	1
2-inch ²	1 and	1
3-inch ¹	4 or	2
3-inch ²	2 and	2
4-inch ¹	8 or	4
4-inch ²	4 and	4

¹Total of each size.
²Combination of sizes.

3. Pressure sterilizers. Sterilizer vent stacks shall be 2-1/2 inches minimum; those serving combinations of pressure sterilizer exhaust connections shall be sized according to Table 23.

Table 23
VAPOR VENT STACK SIZES FOR PRESSURE STERILIZERS
 (Number of connections of various sizes permitted to various sized vent stacks)

Stack size	Connection size			
	¾"	1"	1¼"	1½"
1½-inch ¹	3 or	2 or	1	
1½-inch ²	2 and	1		
2-inch ¹	6 or	3 or	2 or	1
2-inch ²	3 and	2		
2-inch ²	2 and	1 and	1	
2-inch ²	1 and	1 and		1
3-inch ¹	15 or	7 or	5 or	3
3-inch ²		1 and	2 and	2
3-inch ²	1 and	5 and		1

¹Combination of sizes.
²Total of each size.

4. 'Pressure instrument washer-sterilizer sizes'. The minimum size of a sterilizer vent stack serving an instrument washer-sterilizer shall be 2 inches in diameter. Not more than 2 sterilizers shall be installed on a 2-inch stack, and not more than 4 on a 3-inch stack.

(9) FLOOR DRAINS PROHIBITED. Floor drains shall not be installed in operating or delivery rooms.

(10) WATER SUPPLY. (a) *Water services*. All hospitals shall be provided with at least 2 water service connections and whenever more than one street main is available, the connections shall be made to different street mains.

1. The water service pipe for all other health care facilities shall be of sufficient size to furnish water to the building in the quantities and at the pressures required in s. Comm 82.40 (4) and (5) and par. (c).

2. Water services shall be in accord with the requirements of s. Comm 82.40 (2).

(b) *Water distribution control valves*. 1. Four or less patient care units, containing not more than 2 persons per unit exclusive of intensive care coronary units, may be served with one branch control valve. All fixtures, appliances, appurtenances, lawn sprinkler faucets and wall hydrants shall be valved.

2. Control valves for risers, water heating equipment, water softeners and tank controls shall be in accord with s. Comm 82.40. Control valve accessibility and design shall be in accord with s. Comm 82.40.

(c) *Velocities and flow capacities*. Water supply piping shall be designed to provide service to upper floor installations at a minimum pressure of 15 (p.s.i.) pounds per square inch during maximum demand periods. Velocities shall not exceed 8 (f.p.s.) feet per second. Where static pressure exceeds 80 (p.s.i.) pounds per square inch, pressure reducing controls shall be installed to avoid fracture or other damage to the system. The supply demand in gallons per minute in the building water distribution system shall be determined on the basis of the load in terms of supply fixture units and of the relationship between load and supply demand as shown in Table 24 and pertinent portions of Tables 13 and 14.

Table 24
DATA FOR ESTIMATING WATER SUPPLY DEMAND AND WASTE REQUIREMENTS

Fixture	Fixture Units			Minimum Pipe Sizes, Inches				Remarks
	Water	Waste	Waste	Trap	Vent	Cold Water	Hot Water	
Water closet (tank)	6	6	3	2	2	3/8	1/2	H.W. required with bedpan
Water closet (flush valve)	10	8	3	2	2	1	1/2	washer hose only
Lavatory	2	1	1½	1¼	1¼	1/2	1/2	
Urinal (tank)	3	4	2	2	1½	1/2	—	
Urinal (flush valve)	5	4	—	—	—	1	—	
Shower	4	2	3 FD	3	—	1/2	1/2	
Patient bath (public)	4	3	1½	1½	1½	1/2	1/2	
Patient bath (pvt.)	2	3	1½	1¼	1½	1/2	1/2	

Table 24 - (continued)

Drinking fountain	1	1/2	1/4	1/4	1/4	1/2	—	
Sitz bath	4	3	1 1/2	1 1/2	1 1/2	1/2	1/2	
Clinical sink	10 CW	6	3	3	2	1	3/4	
(Flushing rim)	4 HW	—	—	—	—	—	—	
Scrub sink	4	3	2	2	1 1/2	3/4	3/4	2, 3 or 4 place sink
Single sink for misc. hospital use	3	3	1 1/2	1 1/2	1 1/2	1/2	1/2	
Double sink for misc. hospital use	4	4	2	2	1 1/2	3/4	3/4	
Laboratory sink	2	2	1 1/2	1 1/2	1 1/2	1/2	1/2	
Ice machine	1	1	2 SD	2	1 1/2	3/4	—	
Plaster sink	6	4	2	2	1 1/2	3/4	3/4	Use with plaster trap
X-ray tank	4	2	1 1/2	1 1/2	1 1/2	1/2	1/2	Based on 18 x 30 x 22-inch tank
Bedpan sanitizer	10	6	3	2	2	1	—	1/2-inch STM connection
Autopsy table	4	4	1 1/2	1 1/2	1 1/2	1/2	1/2	
Animal area sinks	4	4	2	2	1 1/2	3/4	3/4	
Cup sink	1	1	1 1/4	1 1/4	1 1/4	1/2	—	

(d) *Piping insulation.* Circulating, hot, cold and chilled water piping shall be insulated. Cold and chilled water pipe insulation shall have an integral or separate vapor barrier.

(e) *Special piping systems.* Distilled water, ionized water, laboratory and other special piping systems shall be included in the plans submitted. The plans shall incorporate sufficient detail to clearly establish the installation proposed.

(g) *Hot water supply control.* Hot water supply to patients' showers, therapeutic equipment, and continuous baths shall be provided with control valves automatically regulating the temperature of the water supply to the fixture. The valve shall fail in a closed position when the tempered water supply to the fixture

exceeds 110°F.

(h) *Hot water supply.* The water supply distribution system shall be designed to provide hot water at each applicable fixture at all times. The system shall be of a circulating type. The circulating pumps shall be arranged for continuous operation or shall be controlled by an aquastat in the circulating piping. See s. Comm 82.40 (5).

(i) *Water heaters and tanks.* Storage tanks when provided shall be fabricated of non-corrosive metal or be lined with non-corrosive material. The water heating equipment shall have a sufficient capacity to supply water at the temperature and amounts in Table 26.

Table 26

	Patient Areas	Clinical	Dietary	Laundry (2 gals. per lb. of laundry)
Gal/hr/bed	6-1/2	6-1/2	4	4-1/2
Temp. °F. (Maximum)	110°	125°	180°	180°

(11) **ASPIRATORS.** The use of water aspirators shall be limited to those units approved by the department.

(12) **SPOUTS AND ACTIONS—HOSPITAL AND NURSING HOME FIXTURES.** (a) The selection of spouts and actions for hospital and nursing home plumbing fixtures shall comply with par. (b) and Table 27.

(b) Lavatories and sinks required in patient care areas shall

have the water supply spout mounted so that its discharge point is a minimum distance of 5 inches above the rim of the fixture. All fixtures used by medical and nursing staff, and all lavatories used by patients and food handlers shall be trimmed with valves which can be operated without the use of hands. Where blade handles are used for this purpose they shall not exceed 4-1/2 inches in length, except that handles on scrub sinks and clinical sinks shall be not less than 6 inches long.

Table 27

SPOUTS AND ACTIONS FOR HOSPITAL AND NURSING HOME FIXTURES

Location	Type of Spout	Type of Action Minimum
NURSING DEPARTMENT		
Patient toilet room	Gooseneck	Wrist
Patient toilet room— isolation	Gooseneck	Knee
Utility room	Gooseneck	Wrist
Treatment room	Gooseneck	Wrist
Medicine room	Gooseneck	Wrist
Lavatory in floor kitchen	Gooseneck	Wrist
Sink in floor kitchen	Sink faucet	Wrist
Nurses toilet room	Lavatory supply	Hand
Floor laboratory	Laboratory gooseneck	Vertical hand

Table 27 – (continued)

NURSERY		
Nursery	Gooseneck	Wrist
Suspect nursery	Gooseneck	Wrist
Examination and treatment	Gooseneck	Wrist
Premature nursery	Gooseneck	Foot
Formula room	Gooseneck	Wrist
Labor room	Gooseneck	Wrist
SURGICAL		
Scrub room	Gooseneck with spray head	Knee
Sub-sterile room	Sink faucet	Wrist
Clean-up room	Sink faucet	Wrist
Frozen sections room	Laboratory gooseneck	Vertical hand
Surgical supply room	Gooseneck	Wrist
Work room	Sink faucet	Wrist
Cystoscopic room	Gooseneck with spray head	Knee
Fracture room	Sink faucet	Wrist
Recovery room	Gooseneck	Foot
CENTRAL SUPPLY		
Work room	Sink faucet	Wrist
Solutions room	Sink faucet	Wrist
Needle and syringe room	Sink faucet	Wrist
Glove room	Gooseneck	Wrist
Pharmacy	Laboratory gooseneck	Vertical hand
Manufacturing	Gooseneck	Wrist
EMERGENCY DEPARTMENT		
Observation bedroom	Gooseneck	Wrist
Utility room	Gooseneck	Wrist
Operating room	Gooseneck with spray head	Knee
D.O.A. room	Gooseneck	Wrist
Examination room	Gooseneck	Wrist
DIAGNOSTIC AND TREATMENT		
Occupational therapy	Gooseneck	Wrist
Hydro-therapy room	Gooseneck	Wrist
Examination room	Gooseneck	Wrist
Deep therapy	Gooseneck	Wrist
Superficial therapy	Gooseneck	Wrist
Radium treatment and exam	Gooseneck	Wrist
Toilet room	Gooseneck	Wrist
Dark room	Sink faucet	Hand
Autopsy	Gooseneck with spray head	Knee
Lavatory in autopsy shower room	Gooseneck	Wrist
Laboratories	Laboratory gooseneck	Vertical hand
OUTPATIENT DEPARTMENT		
Examination and treatment room	Gooseneck	Wrist
Dental operating	Gooseneck	Knee
Dental laboratory	Laboratory gooseneck	Vertical hand
Dental recovery	Gooseneck	Wrist

Table 27 - (continued)

Surgical room	Gooseneck with spray head	Knee
Eye examination room	Gooseneck	Knee
Bar, nose and throat room	Gooseneck	Knee
SERVICE DEPARTMENT		
Lavatory in kitchen	Lavatory supply	Wrist

(13) RADIOACTIVE MATERIALS. See ch. HSS 157.

History: 1-2-56; am. (3) (4) and (5), Register, August, 1961, No. 68, eff. 9-1-61; r. and recr. Register, November, 1972, No. 203, eff. 12-1-72; r. and recr., Register, February, 1979, No. 278, eff. 3-1-79; renum. from H 62.16, Register, July, 1983, No. 331, eff. 8-1-83; renum. from JLHR 82.16 and am. (7) (b), (10) (a) 1. and 2., (b) 2., (f) (intro.) and (h), Register, February, 1985, No. 350, eff. 3-1-85; r. (10) (f) and Table 25, Register, February, 1994, No. 458, eff. 3-1-94.

Comm 82.51 Mobile home sites and parks.

(1) DRAIN SYSTEMS. (a) *Private interceptor main sewer.* The maximum number of mobile homes served by private interceptor main sewer shall be in accordance with Table 82.51.

Table 82.51

MAXIMUM NUMBER OF MOBILE HOMES SERVED BY A PRIVATE INTERCEPTOR MAIN SEWER

Diameter of Private Interceptor Main Sewer (in inches)	Pitch (inch per foot)		
	1/16	1/8	1/4
4	None	7	10
5	12	18	24
6	26	34	49
8	Load Shall Not Exceed Capacity of Pipe ^a		

^a See s. Comm 82.30 (4) (d).

(b) *Building sewer.* The building sewer for a mobile home shall be at least 4 inches in diameter.

(c) *Mobile home drain connector.* The piping between the mobile home drain outlet and the building sewer shall have a minimum slope of 1/4 inch per foot, and shall be of materials approved for above ground drain and vent pipe in accordance with ch. Comm 84. The connector shall be protected against freezing.

(d) *Other requirements.* Mobile home park sewer systems shall also conform to the applicable requirements of s. Comm 82.30.

(2) WATER SUPPLY SYSTEMS. (a) *Private water mains.* 1. Supply demand. The supply demand in gallons per minute in the private water main system shall be determined on the basis of the load in terms of water supply fixture units, and in terms of the relationship between load and supply demand. The demand load of a mobile home site shall be equivalent to at least 15 water supply fixture units.

2. 'Sizing'. The private water mains shall be sized in accordance with s. Comm 82.40. A private water main serving a mobile home park shall not be less than one inch in diameter.

3. 'Pressure'. The minimum pressure within a private water main shall be sufficient to maintain a pressure of 20 psi at each mobile home site under normal operating conditions.

4. 'Valving'. Each private water main shall be provided with a gate or full flow valve at its source and at each branch connection. The valves shall be installed in a manhole or valve box so as to be accessible for operation.

(b) *Water services.* 1. Size. Each mobile home site shall be served by a separate water service not less than 3/4 inch in diameter.

2. Valving. a. Each water service shall be provided with a curb stop within each mobile home site but not under the parking hard stand or pad.

b. A valve, of at least 3/4 inch diameter, shall be located on the upper end of the water service pipe. In lieu of the valve located on the upper end of the water service, a freezeless type hydrant of at least 3/4 inch diameter may be used.

c. The installation of underground stop and waste valves shall be prohibited.

3. 'Mobile home water connector'. The piping between the mobile home water inlet and the water service shall be of materials approved for water distribution pipe in accordance with s. Comm 84.30 (3).

(c) *Protection against freezing.* All water main and water service piping shall be protected against freezing.

(d) *Separation of water and sewer piping.* Separation of water and sewer piping shall be in accordance with ss. Comm 82.30 (11) (d) and 82.40 (8) (b).

(e) *Other requirements.* Mobile home park water supply systems shall also conform to the applicable requirements of s. Comm 82.40.

(3) BUILDING SEWER AND WATER SERVICE TERMINATIONS. (a) *Frost sleeves.* Each building sewer and water service shall have a frost sleeve extending at least 42 inches below grade. The sleeve shall be of a material approved for building sewers. Frost sleeves shall terminate at grade. A frost sleeve shall be covered or sealed when not in use.

(b) *Termination elevation.* Each water service shall terminate at least 6 inches above the surrounding finished grade. Each building sewer shall terminate at least 4 inches above the surrounding finished grade and shall not terminate higher than the water service pipe.

(c) *Piping not in use.* A building sewer or water service pipe not connected to a mobile home shall be capped or plugged.

Note: See Appendix for further explanatory material.

History: Cr. Register, February, 1985, No. 350, eff. 3-1-85; r. and recr. Table, Register, August, 1991, No. 428, eff. 9-1-91; am. (2) (d), Register, February, 1994, No. 458, eff. 3-1-94.

Subchapter VI—Installation

Comm 82.60 Pipe hangers and supports. The provisions of this section control the types, materials and installation of anchors, hangers and supports for plumbing piping.

(1) MATERIAL. (a) *Strength.* Hangers, anchors and supports for piping shall be of sufficient strength to support the piping and its contents. Drain piping shall be considered as being full of water. Underground piers for pipe support shall be of concrete, masonry, plastic or pressure treated wood.

(b) *Compatibility.* 1. Hangers and straps shall be of a compatible material that will reduce the potential for galvanic action with the piping.

2. Hangers and straps may not distort, cut or abrade piping.

(2) INSTALLATION. (a) Piping hangers and anchors shall be securely attached to the building's structure at intervals to support the piping and its contents, but not at intervals greater than those specified in Table 82.60. The connection of drain piping to a fixture or appliance shall be considered a point of support.

(b) Hubless pipe installed in the horizontal position shall be supported within 24 inches on each side of a joint, unless the joint has an alignment retaining shield.

(c) Hangers shall not be attached to a building's structure by means of wood plugs.

Table 82.60
Support Spacing

Material	Maximum Horizontal Spacing (feet)	Maximum Vertical Spacing (feet)
Acrylonitrile Butadiene Styrene (ABS)	4	10
Brass	10	10
Cast iron	5 ^a	15
Copper or Copper-Alloy Pipe	12	10
Copper or Copper-Alloy Tubing:		
≤ 1¼" diameter ^c	6	10
≥ 1½" diameter ^c	10	10
Chlorinated Polyvinyl Chloride (CPVC):		
≤ 1" diameter ^c	3	5 ^b
≥ 1¼" diameter ^c	4	6 ^b
Crosslinked Polyethylene (PEX)	2 2/3	4
Ductile Iron	5 ^a	15
Galvanized Steel	12	15
Lead	Continuous	4
Polybutylene (PB)	2 2/3	4
Polyvinyl Chloride	4	10
Stainless Steel	12	15

^a The maximum horizontal spacing for supports may be increased to 10 feet when 10-foot lengths of pipe are employed.

^b Mid-story guide is to be employed.

^c "≥" means greater than or equal to.

"≤" means less than or equal to.

History: Cr. Register, February, 1985, No. 350, eff. 3-1-85; r. and recr. Register, May, 1988, No. 389, eff. 6-1-88; r. and recr. Table 82.60, Register, February, 1994, No. 458, eff. 3-1-94.

Chapter Comm 82

APPENDIX

The material contained in this appendix is for clarification purposes only. The notes, illustrations, etc., are numbered to correspond to the number of the rule as it appears in the text of the code.

A-82.11 (29) BRANCH INTERVALS.

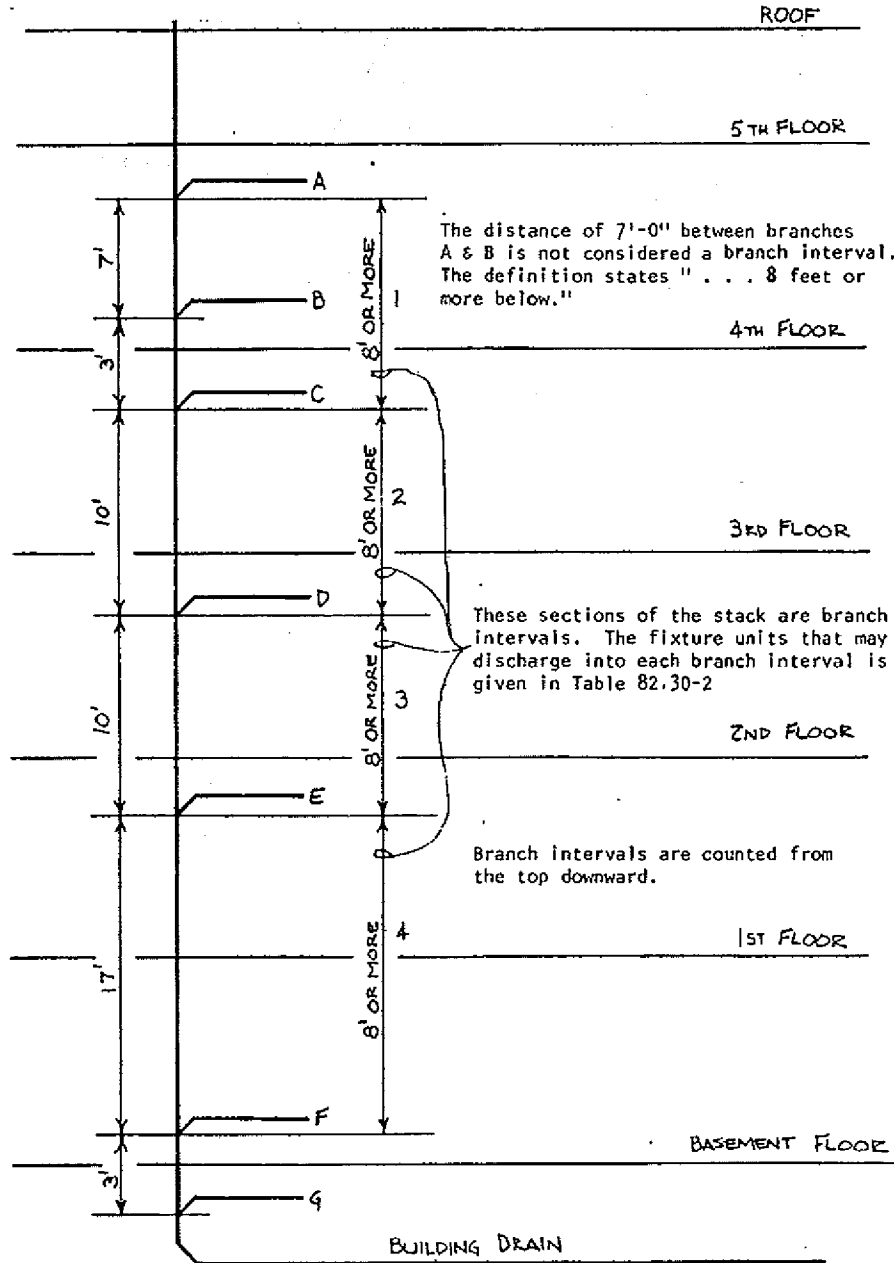

A-82.11 (140) SPRINGLINE OF PIPE

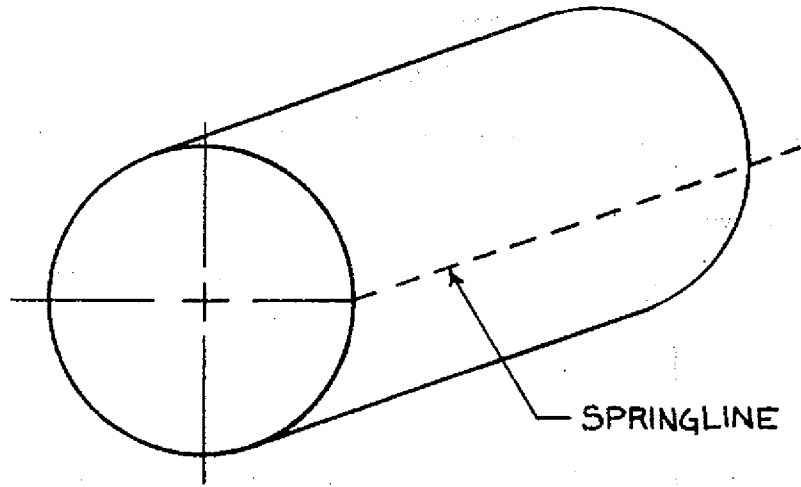

On a round pipe the springline is along the horizontal centerline.

A-82.20 (2) AGENT MUNICIPALITIES. The department has designated to the following municipalities, the authority to review and approve plumbing plans and specifications for those plumbing installations to be located within the municipality's boundary limits and which require approval under s. Comm 82.20 (1) (b).

Appleton
100 N. Appleton Street
Appleton, WI 54911-4799
(414) 832-6411

Eau Claire
203 South Farwell Street,
Eau Claire, WI 54701
(715) 839-4947

Green Bay
100 N. Jefferson St., Rm. 403
Green Bay, WI 54301
(414) 448-3295

Greenfield
7325 W. Forest Home Ave.
Greenfield, WI 53220
(414) 543-5500

Janesville
P. O. Box 5005
Janesville, WI 53547-5005
(608) 755-3064

Kenosha
Dept. of Housing
625 52nd St., Rm. 100
Kenosha, WI 53140
(414) 658-4263

Madison
P. O. Box 2984
Madison, WI 53701-2984
(608) 266-4568

Milwaukee
Municipal Bldg., Rm. 1017
841 N. Broadway Street
Milwaukee, WI 53202
(414) 286-3364

Oshkosh
215 Church Ave.
Oshkosh, WI 54901
(414) 236-5052

Racine
730 Washington Ave.
Racine, WI 53403
(414) 636-9164

Sheboygan
City Hall - 3rd Floor
828 Center Ave.
Sheboygan, WI 53081
(414) 459-3479

Two Rivers
P. O. Box 87
Two Rivers, WI 54241
(414) 793-5580

A-82.20 (4) PLANS AND SPECIFICATIONS. The following is a list of water quality management agencies and the areas they serve.

AGENCY

AREAS SERVED

East Central Wisconsin Regional Planning Commission
132 Main Street
Menasha, WI 54952
(414) 751-4770

Counties of Menominee, Shawano, Waupaca, Outagamie, Waushara, Marquette, Green Lake, Winnebago, Calumet, Fond du Lac

Dane County Regional Planning Commission
217 South Hamilton, Room 403
Madison, WI 53703
(608) 266-4137

County of Dane

Brown County Planning Commission
100 N. Jefferson Street, Room 608
Green Bay, WI 54301
(414) 448-3400

County of Brown

Southeastern Wisconsin Regional Planning Commission
916 North East Avenue
P. O. Box 1607
Waukesha, WI 53187-1607
(414) 547-6721

Counties of Washington, Ozaukee, Waukesha, Milwaukee, Walworth, Racine, Kenosha

West Central Wisconsin Regional Planning Commission
800 Wisconsin Street, Mailbox 9
Eau Claire, WI 54703-3606
(715) 836-2918

Cities of Eau Claire, Altoona, Chippewa Falls
Towns of Hallie, Seymour, Union, Washington

St. Croix County Planning Office
1101 Carmichael Road
Hudson, WI 54016
(715) 286-4673

City of Hudson
Towns of Hudson, St. Joseph, Troy
Village of North Hudson

Bay-Lake Regional Planning Commission
211 N. Broadway, Suite 211
Green Bay, WI 54303
(414) 448-2820

Cities of Marinette, Kohler, Sheboygan, Sheboygan Falls, Sturgeon Bay
Towns of Peshtigo, Porterfield, Mosel, Wilson, Lima, Herman, Sheboygan, Sheboygan Falls

AGENCY (continued)

Rock County Planning Agency
51 South Main Street
Janesville, WI 53545
(608) 757-5587

Office of City Engineer
400 LaCrosse Street
LaCrosse, WI 54601
(608) 789-7505

Portage County Planning Department
1516 Church Street
Stevens Point, WI 54481
(715) 346-1334

Marathon County Planning Department
210 River Drive
Wausau, WI 54403
(715) 847-5227

Wood County Planning
400 Market Street
Wisconsin Rapids, WI 54495
(715) 421-8466

Dunn County Land Conservation
390 Red Cedar Street
Menomonie, WI 54751
(715) 232-1520

AREAS SERVED

Cities of Janesville, Beloit, Edgerton, Evansville, Milton
Towns of Beloit, Harmony, Rock, Janesville, LaPrairie, Turtle

Cities of LaCrosse, Onalaska
Towns of Onalaska, Shelby, Medary, Campbell

City of Stevens Point
Towns of Hull, Plover, Linwood
Villages of Whiting, Plover, Park Ridge

Cities of Wausau, Schofield
Towns of Weston, Stettin, Rib Mountain, Kronenwetter
Village of Rothschild

City of Wisconsin Rapids
Towns of Grand Rapids, Rudolph, Sigel, Seneca, Grant
Village of Biron

City of Menomonie

A-82.30 (4) SIZE OF DRAIN PIPING. The following tables list the maximum GPM which can be expected to readily flow through a given size trap where the receptor has a height as indicated.

Also listed is a maximum drainage fixture unit load which a given size receptor trap may be expected to adequately receive.

Note: The department recommends an individual 4-inch diameter minimum trap and drain pipe for a commercial type dishwasher.

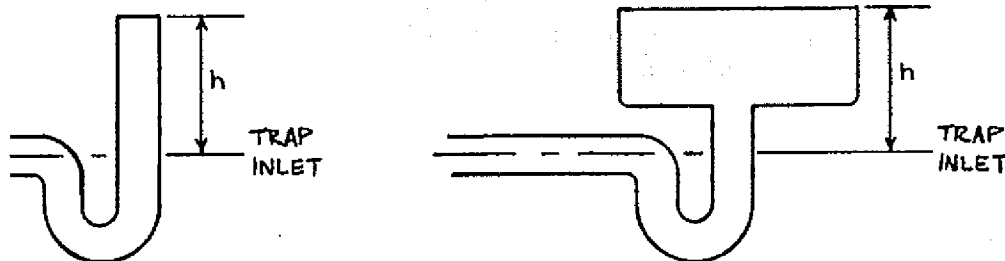

Receptor Trap Size	H - Height	GPM	d.f.u.
1-1/2"	12"	4	2
2"	14"	8	4
3"	15"	12	6
4"	17"	40	20
5"	20"	70	35
6"	22"	120	60
8"	25"	250	125

A-82.30 (6) (b) OFFSETS IN VERTICAL DRAINS.

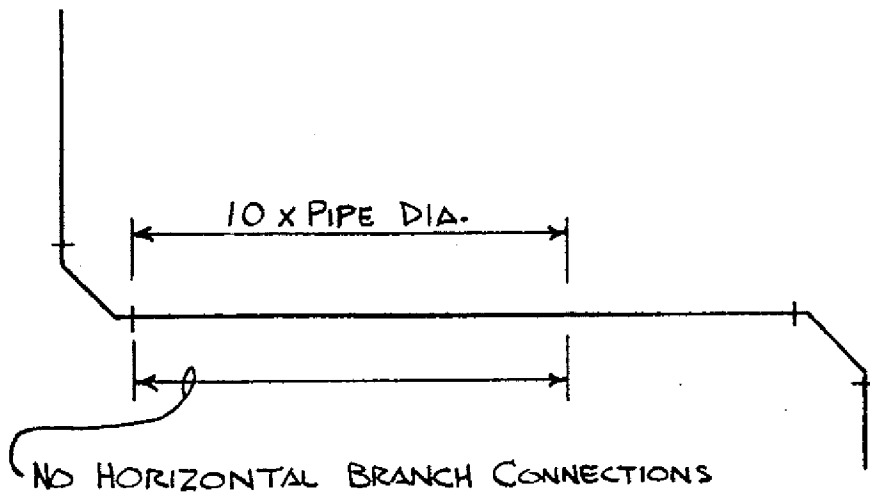
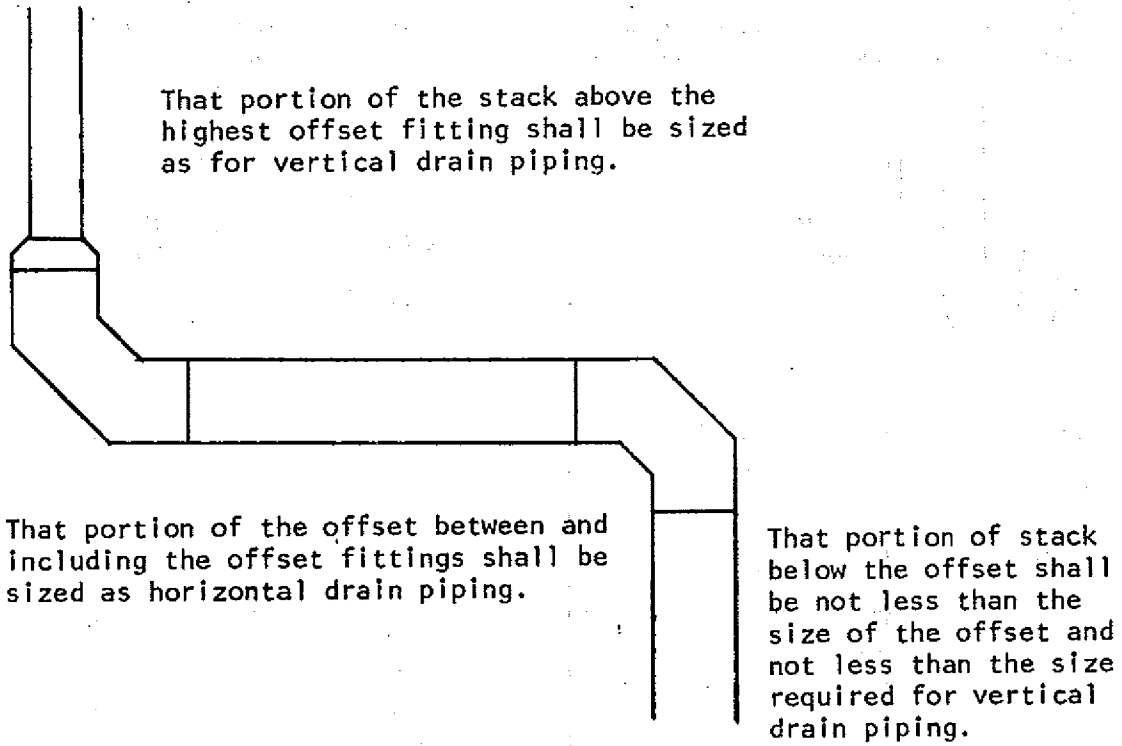

A-82.30 (7) HORIZONTAL BRANCH DRAIN CONNECTION AT BASE OF A STACK.

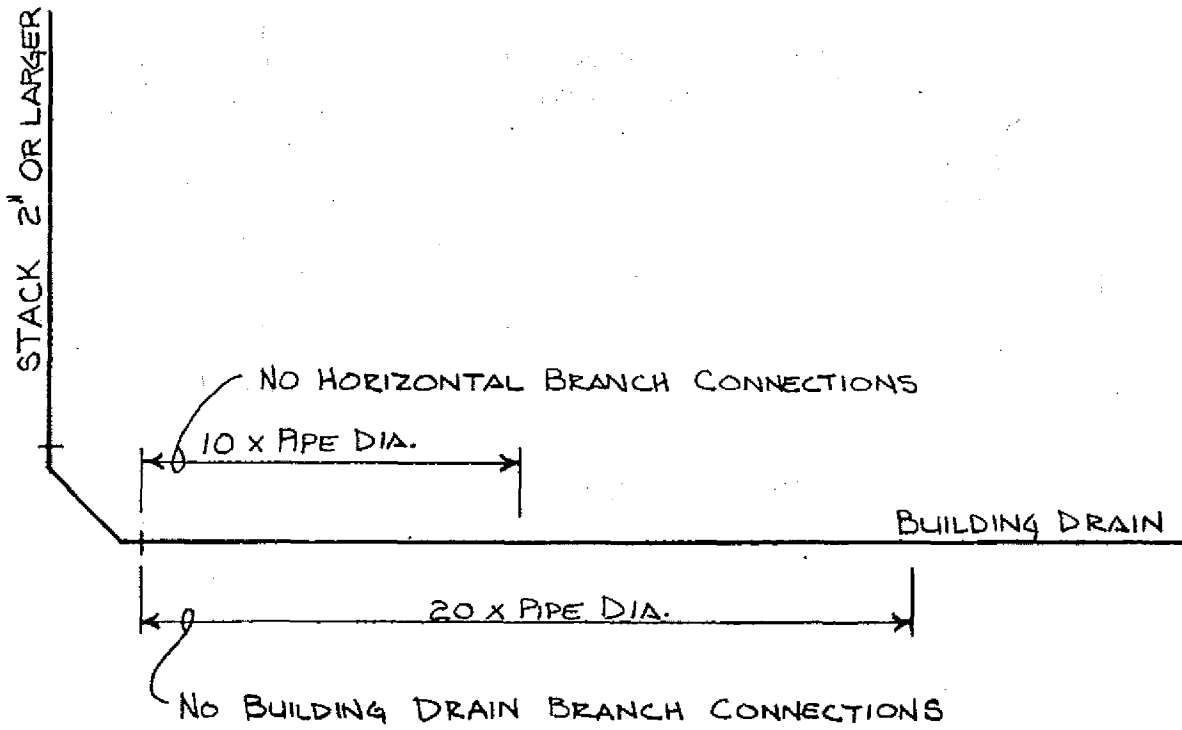

A-82.30 (8) MEASURING RADIUS OF A FITTING.

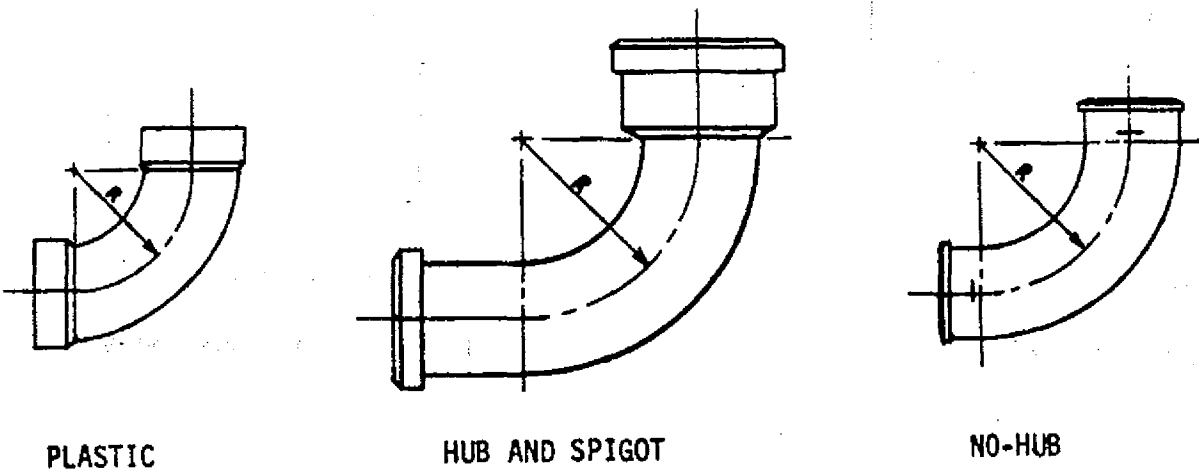

A-82.30 (9) DRAIN FITTINGS AND CONNECTIONS.

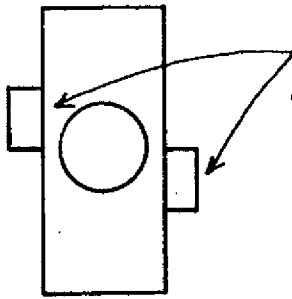

SIDE VIEW

SHALL NOT BE USED
AS A VENT CONNECTION

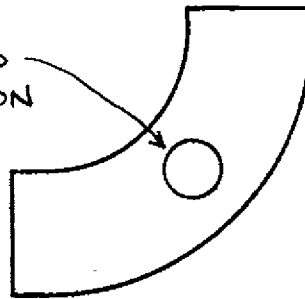

SIDE VIEW

SIDE INLETS

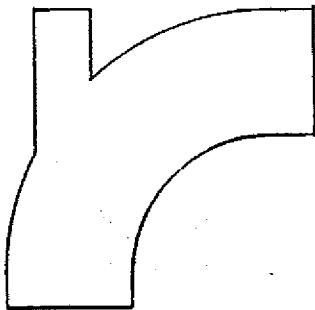

ALLOWED
(SIDE VIEW)

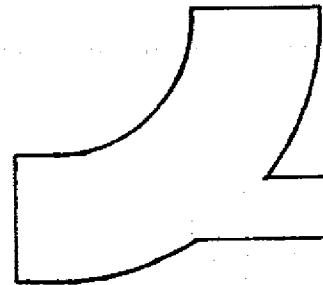

NOT ALLOWED
(TOP VIEW OR SIDE VIEW)

HEEL INLETS

A-82.30 (10) (a) DETERMINING REQUIRED CAPACITY OF SANITARY PUMP.

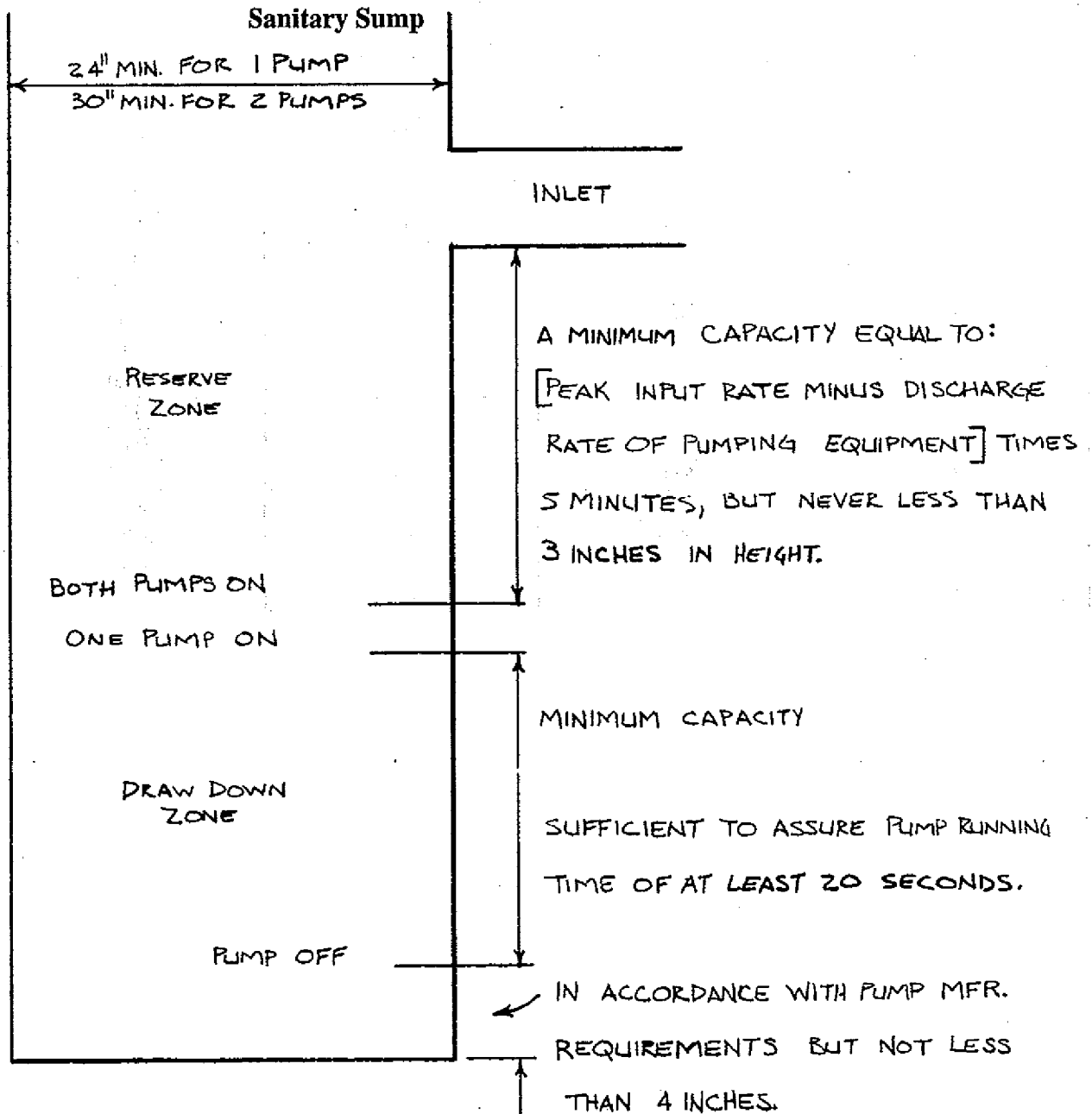

A-82.30 (10) (a) Sumps.

Capacity of sumps
(in gallons)

Diameter of sump in inches	Volume in gal/ft	Diameter of sump in inches	Volume in gal/ft
24	23.5	41	68.6
25	25.5	42	72.1
26	27.6	43	75.5
27	29.7	44	79.1
28	32.0	45	82.7
29	34.3	46	86.5
30	36.8	47	90.2
31	39.2	48	94.0
32	41.8	54	119.0
33	44.5	60	147.0
34	47.2	66	178.0
35	50.0	72	211.5
36	52.8	78	248.4
37	55.9	84	288.1
38	59.0	90	330.8
39	62.1	96	376.3
40	65.3	108	477.3

A-82.30 (11) (b) BUILDING DRAINS SERVING ANY BUILDING.

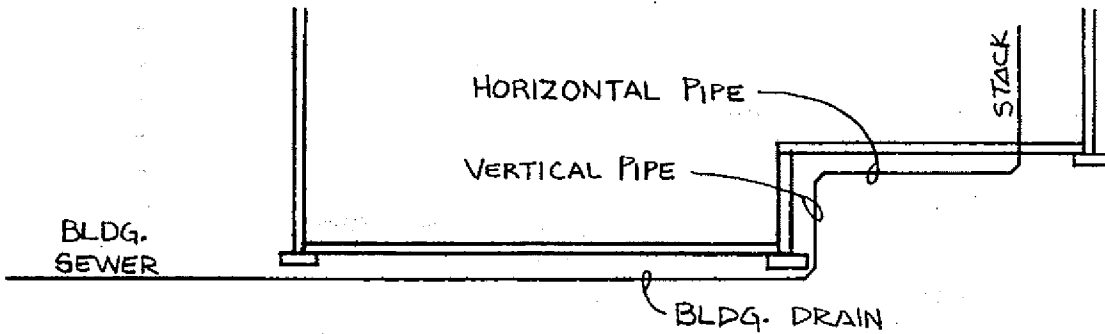
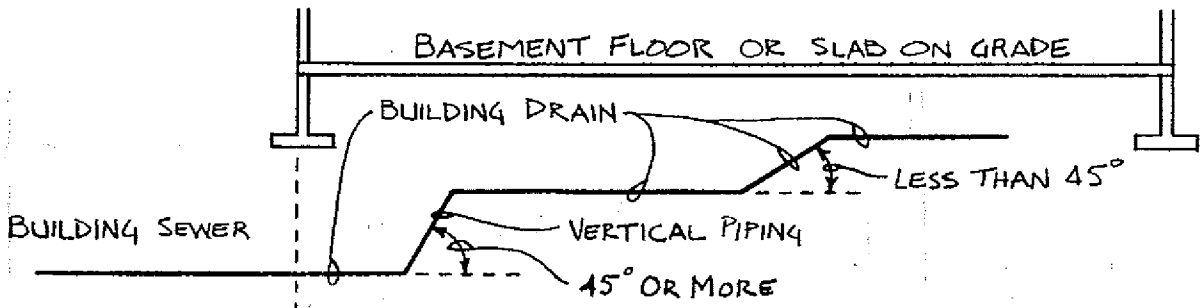

A-82.30 (11) (b) BUILDING DRAINS.

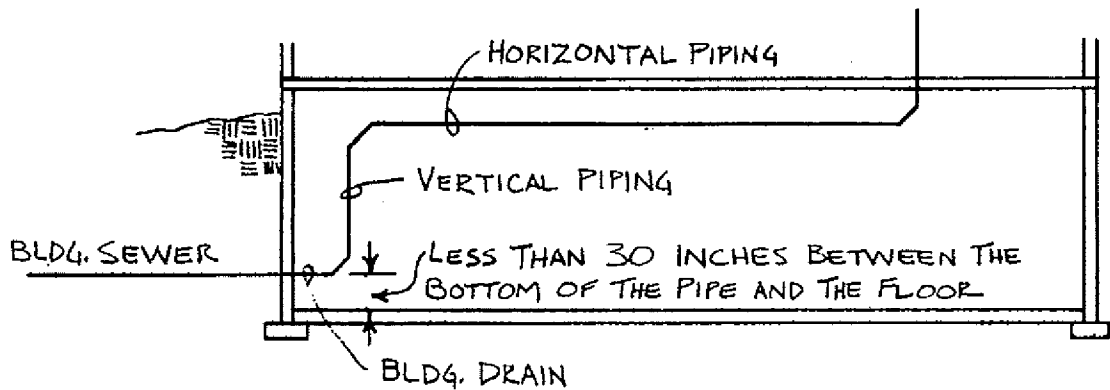
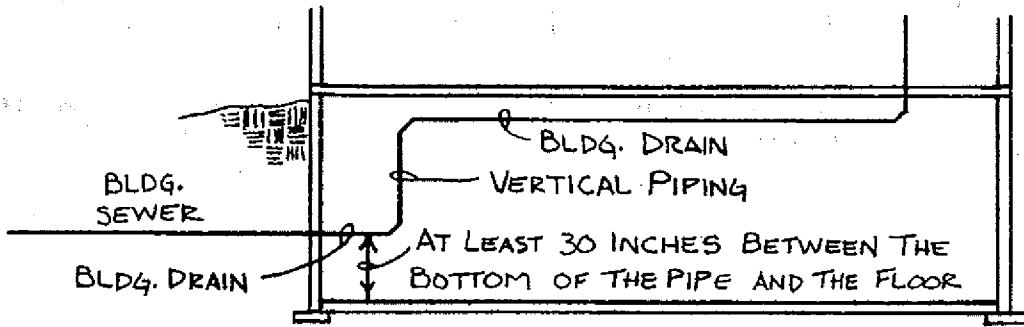

A-82.30 (11) (b) FLOOR DRAIN REQUIRED.

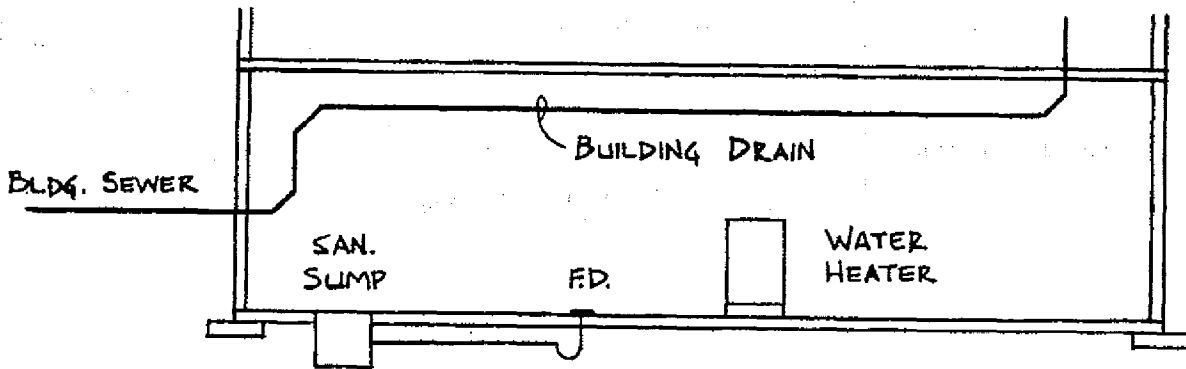

A-82.30 (11) (f) CONNECTION TO PRESSURIZED PUBLIC SEWER.

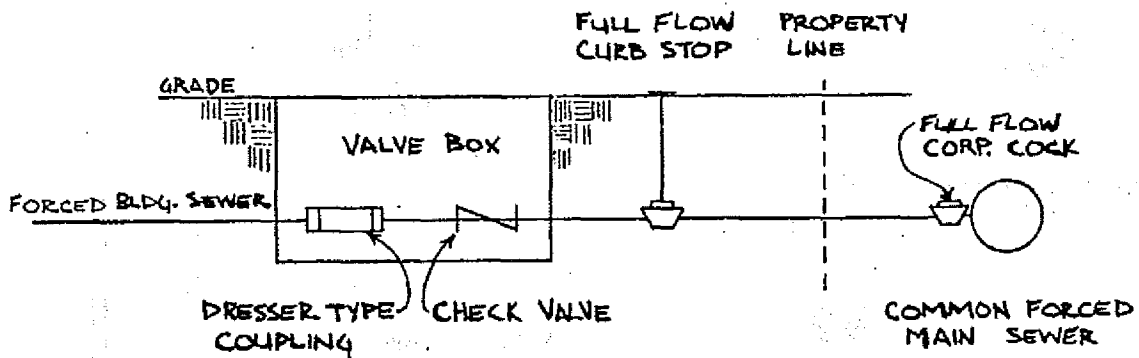

A-82.31 (4) (a) WHERE A VENT STACK AND STACK VENT ARE REQUIRED.

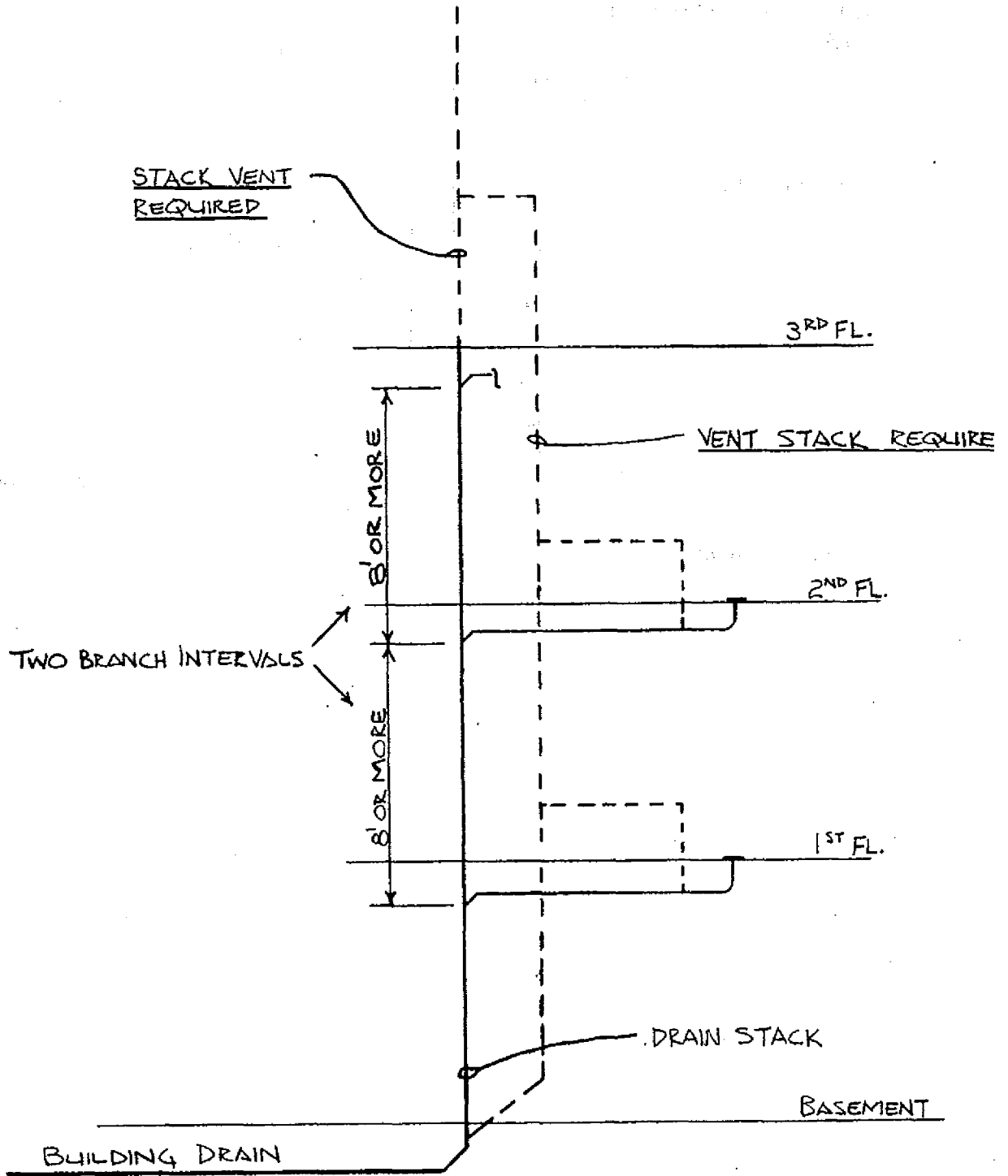

A-82.31 (4) (a) WHERE A VENT STACK AND STACK VENT ARE NOT REQUIRED.

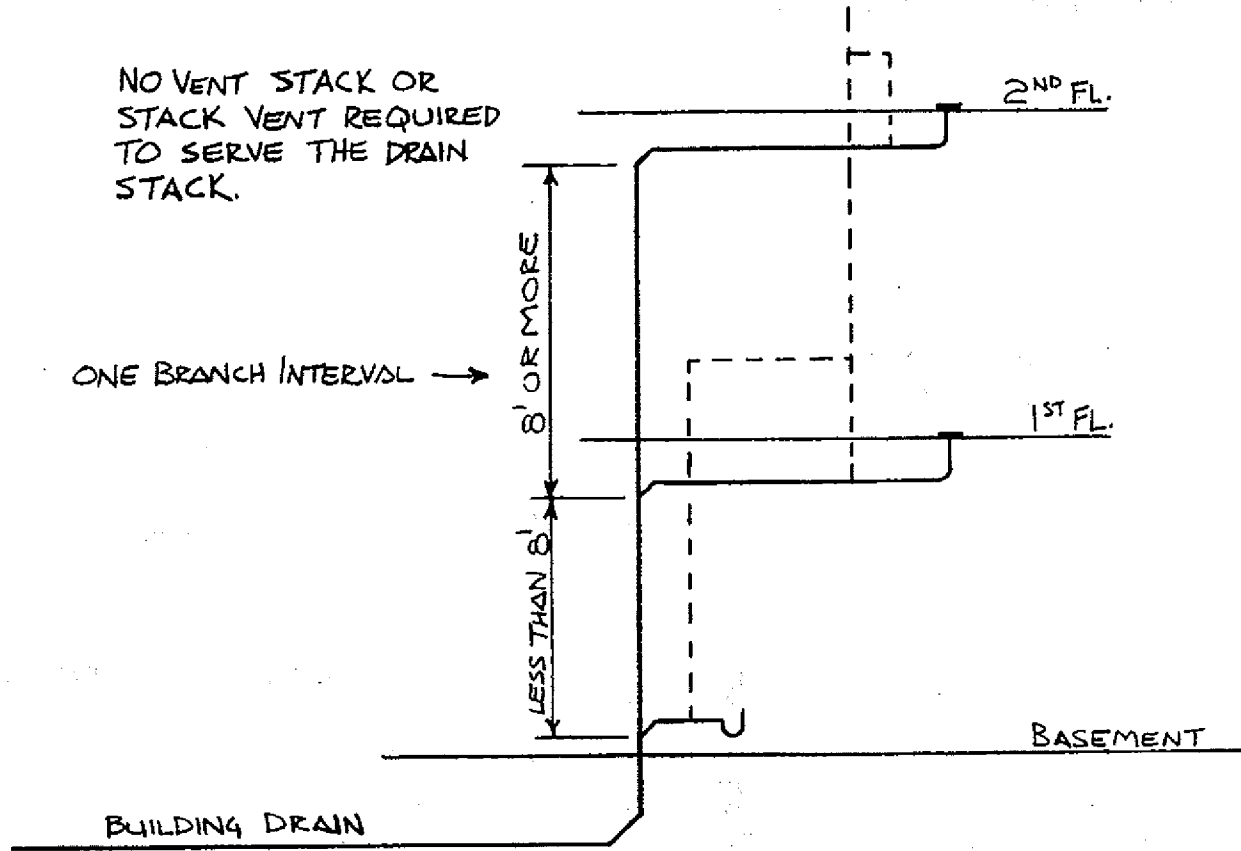

A-82.31 (4) (b) INSTALLATION OF VENT STACK AND STACK VENT.

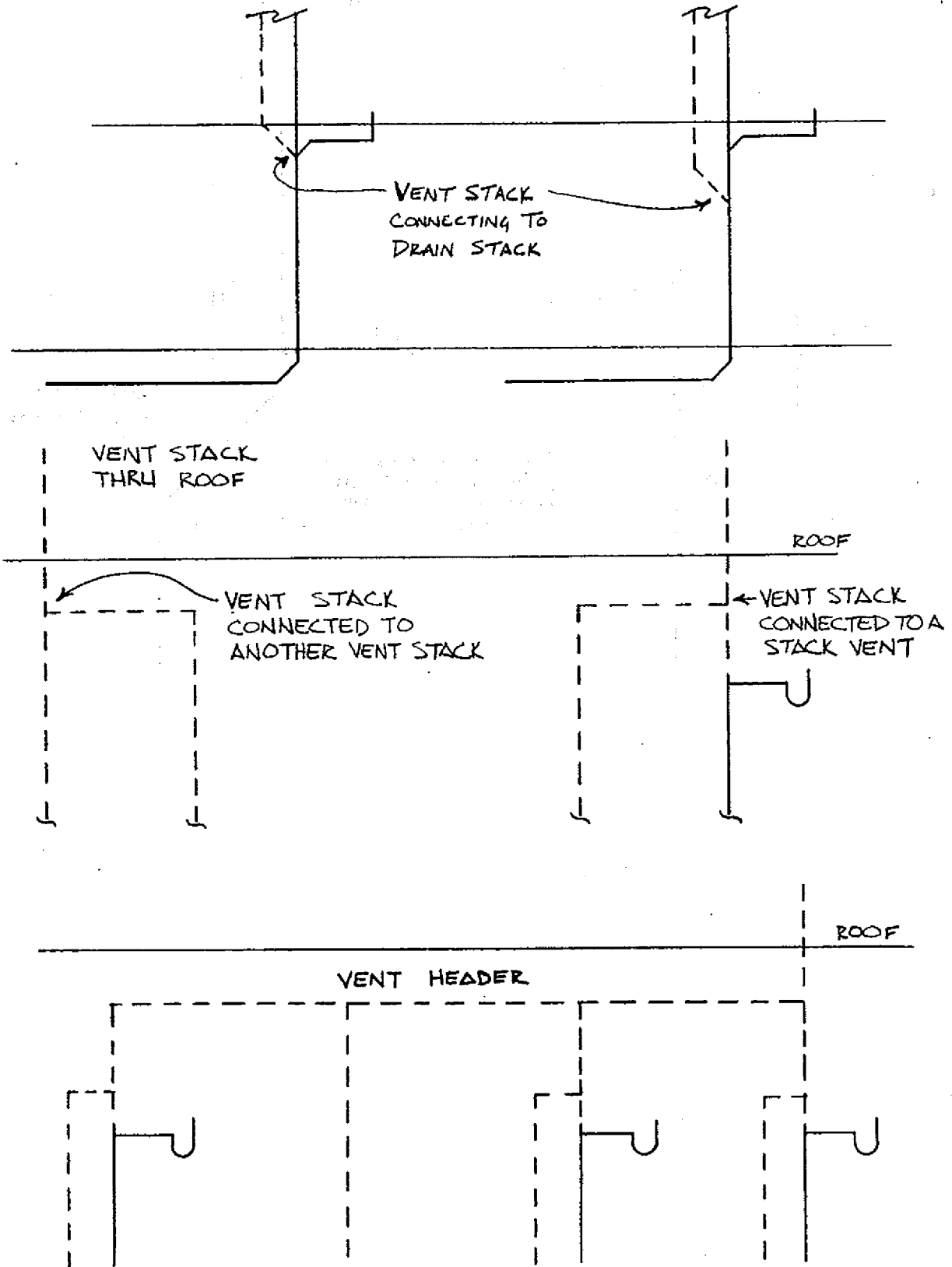

A-82.31 (5) (a) Relief vent for offsets of 30 to 45 degrees.

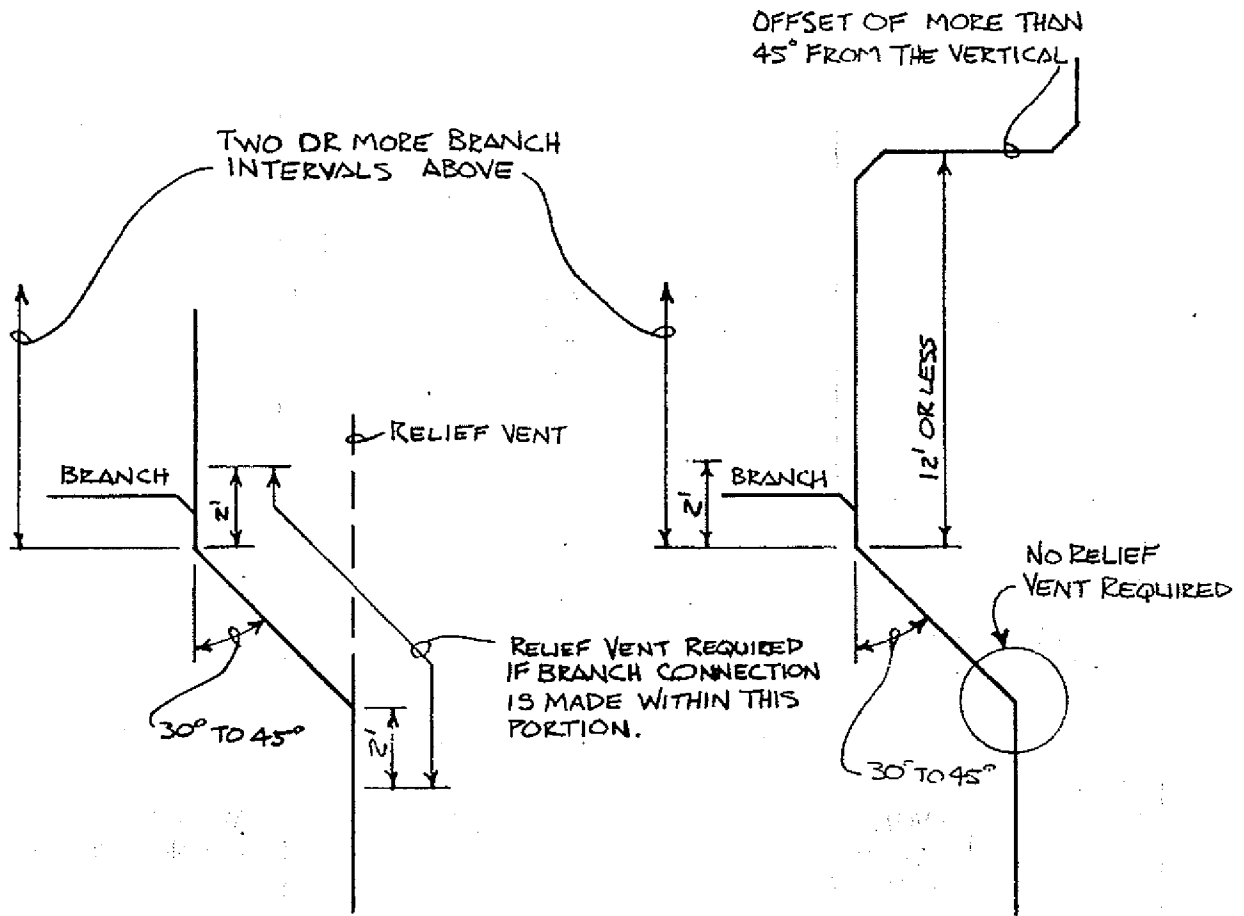

A-82.31 (5) (b) RELIEF AND YOKE VENTS FOR OFFSETS OF MORE THAN 45 DEGREES.

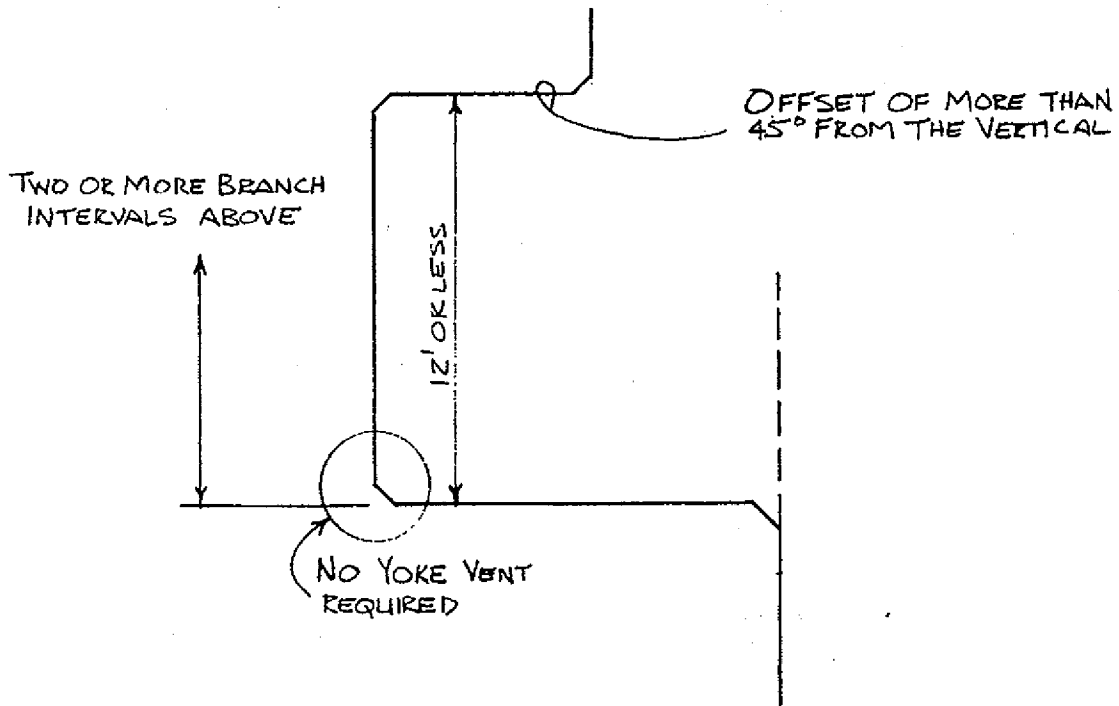
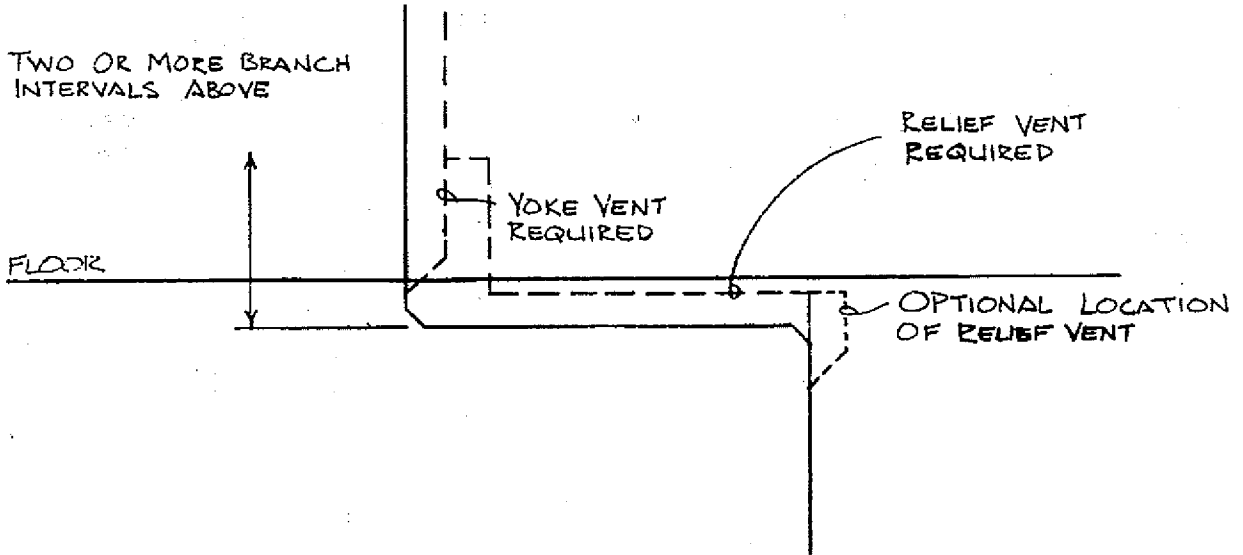

A-82.31 (7) RELIEF VENTS FOR BUILDING DRAINS.

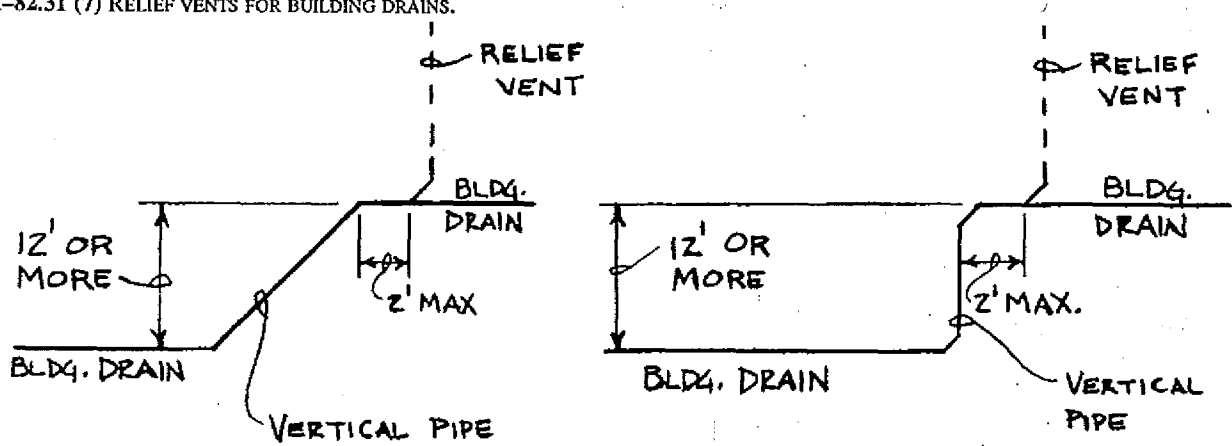

A-82.31 (9) FIXTURE VENTS.

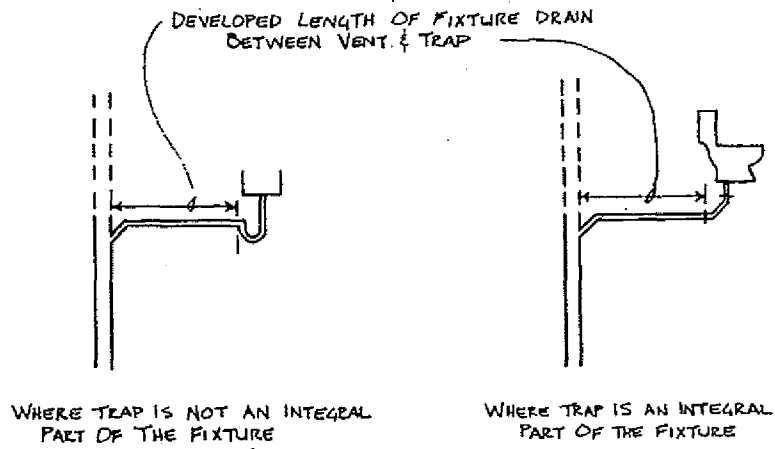

VENT CONNECTING TO HORIZONTAL DRAIN PIPING

VENT CONNECTING TO VERTICAL DRAIN PIPING

BY MEANS OF A SANITARY TEE FITTING

BY MEANS OF A WYE PATTERN FITTING

A-82.31 (10) CIRCUIT VENTING.

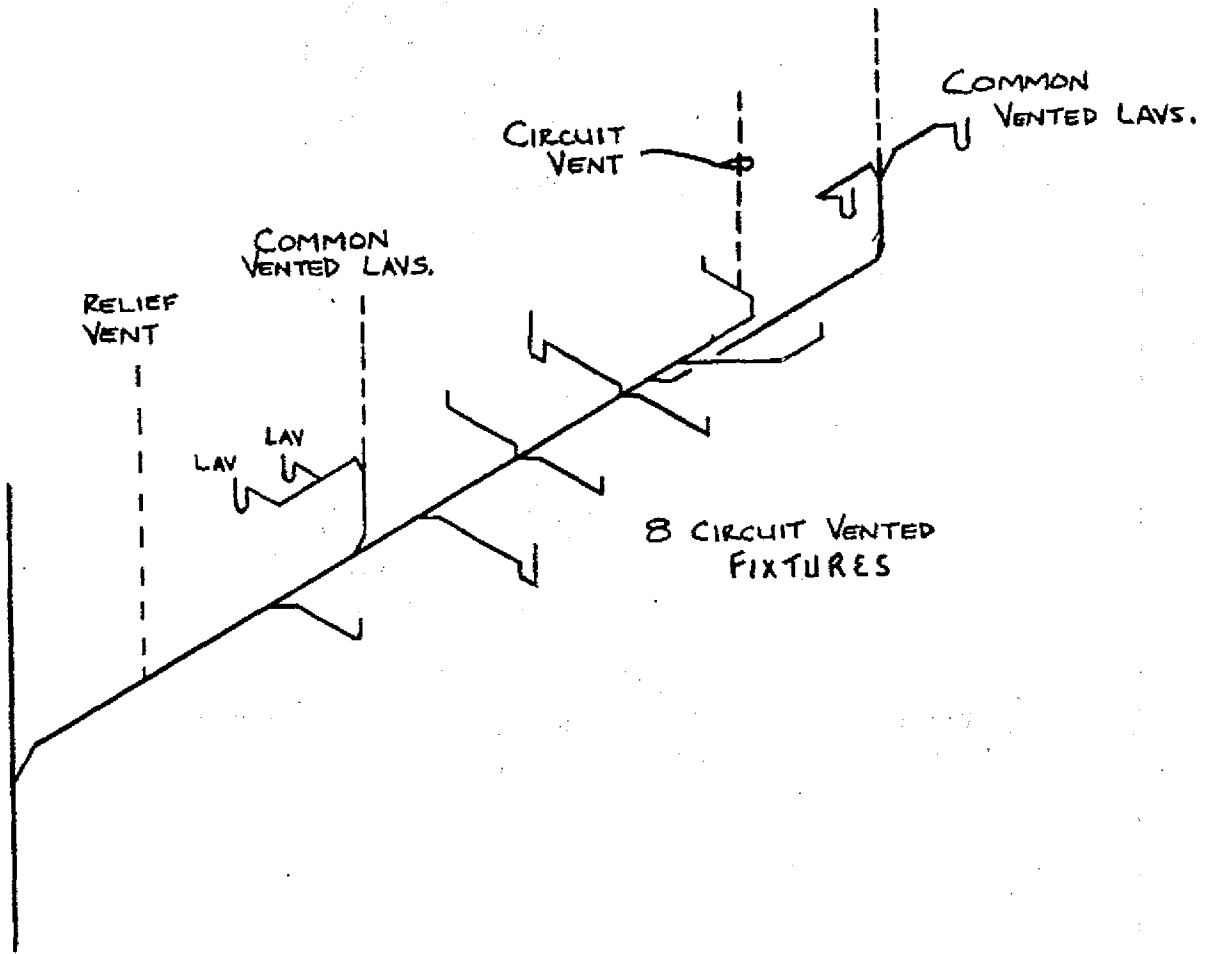

A-82.31 (10) CIRCUIT VENTING.

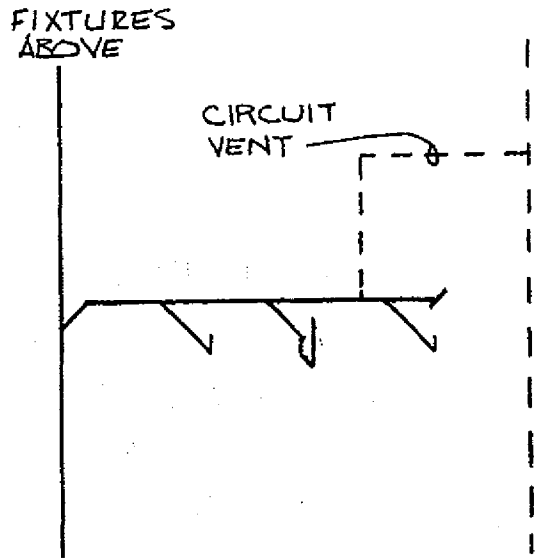
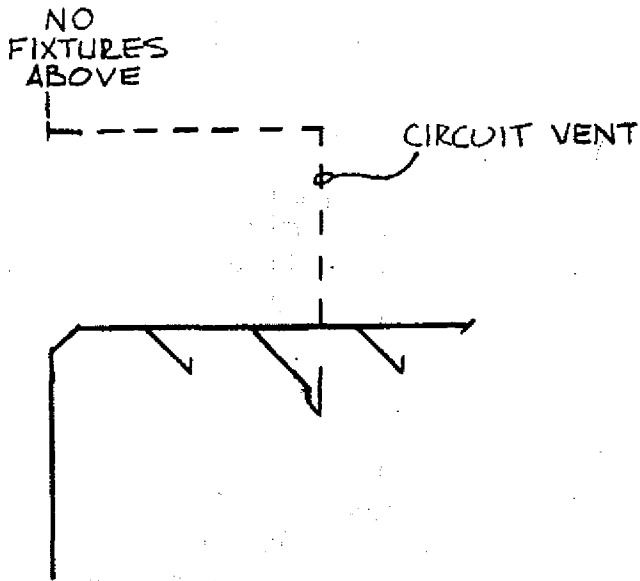

CIRCUIT VENTING
3 FIXTURES

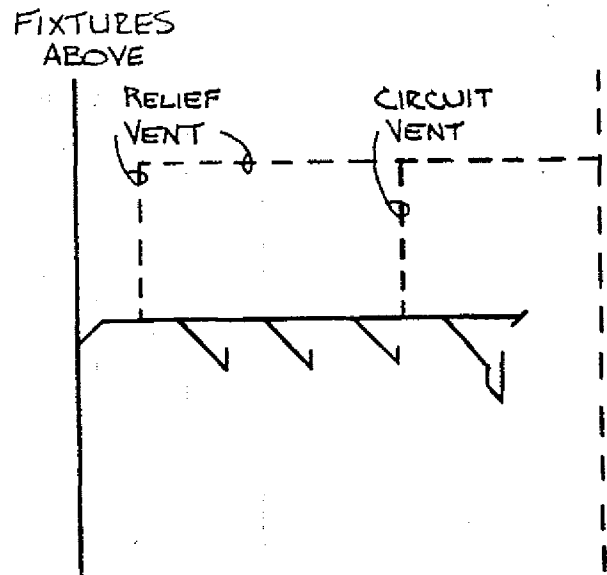
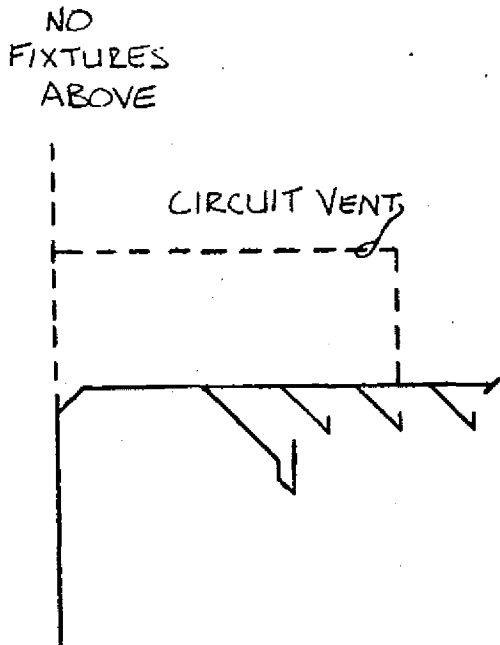

CIRCUIT VENTING 4 OR
MORE FIXTURES

A-82.31 (10) CIRCUIT VENTING.

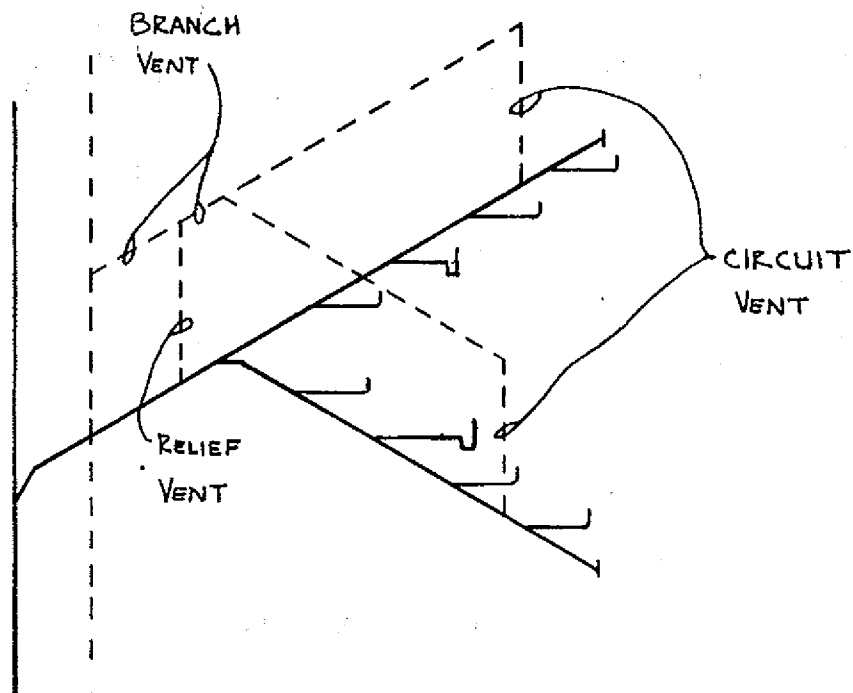
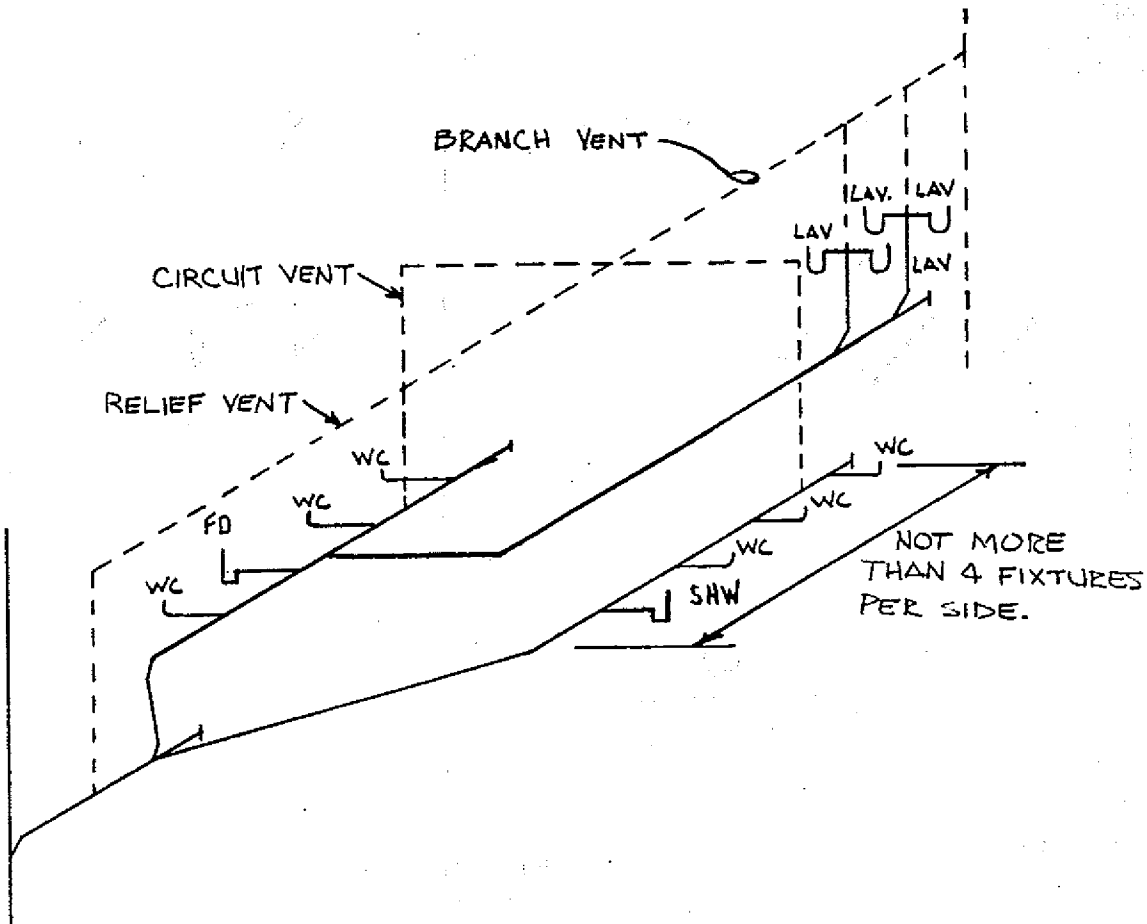

A-82.31 (11) (a) COMMON VENTS, VERTICAL DRAINS.

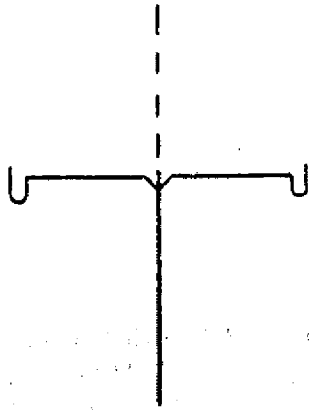

BACK-TO-BACK

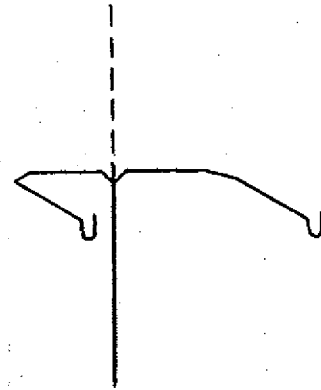

SIDE-BY-SIDE

COMMON VENT SERVING ANY TWO FIXTURES

A-82.31 (11) (b) COMMON VENTS, HORIZONTAL DRAINS.

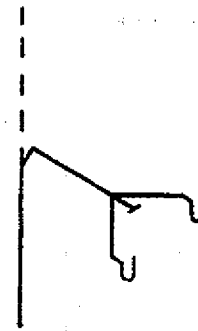
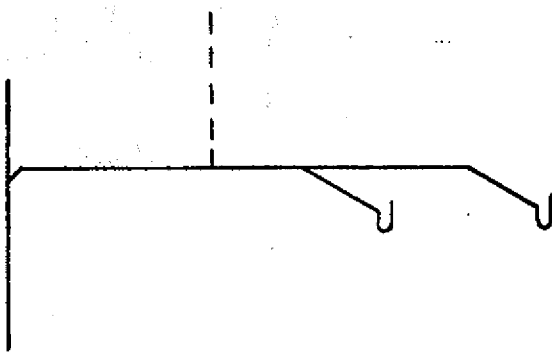
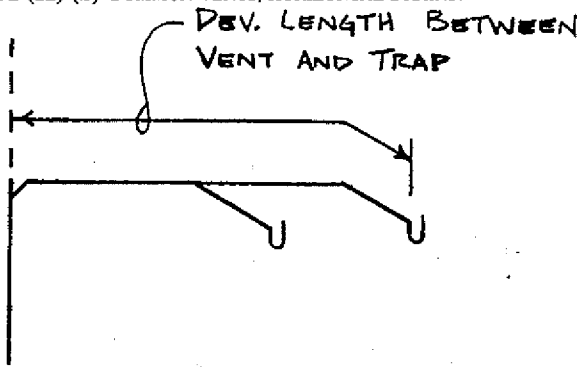

A-82.31 (12) ISLAND FIXTURE VENTING.

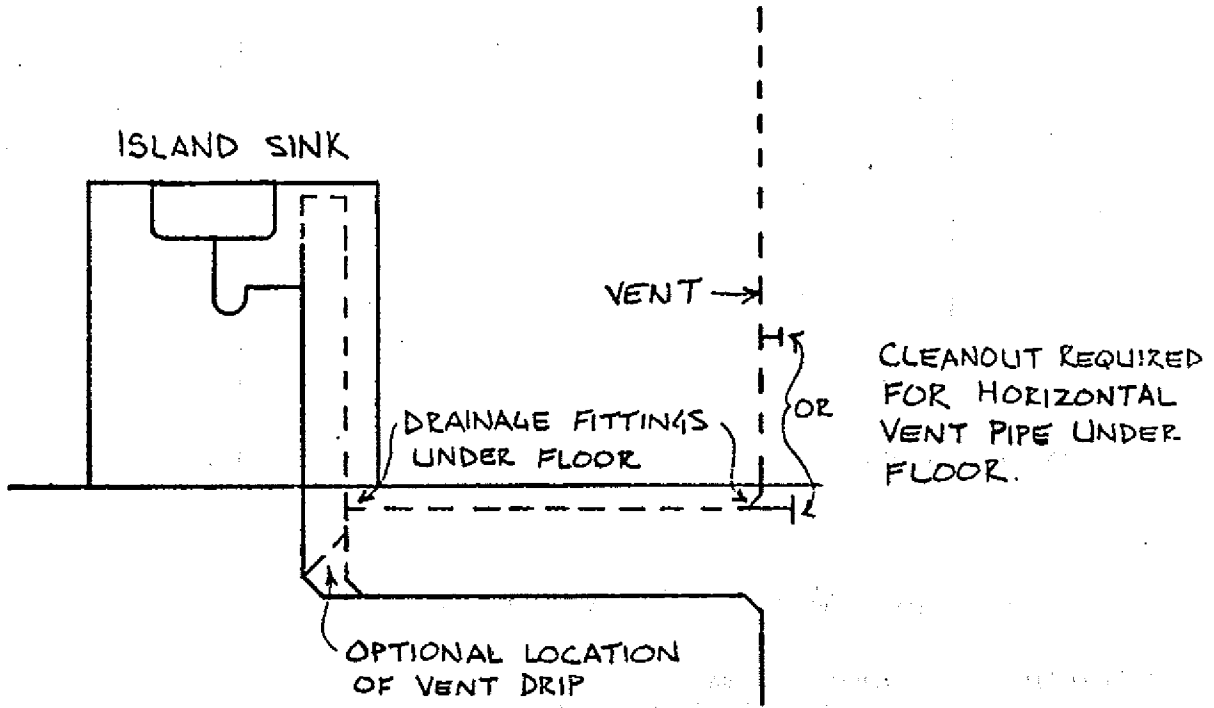

A-82.31 (13) (a) VERTICAL WET VENTS.

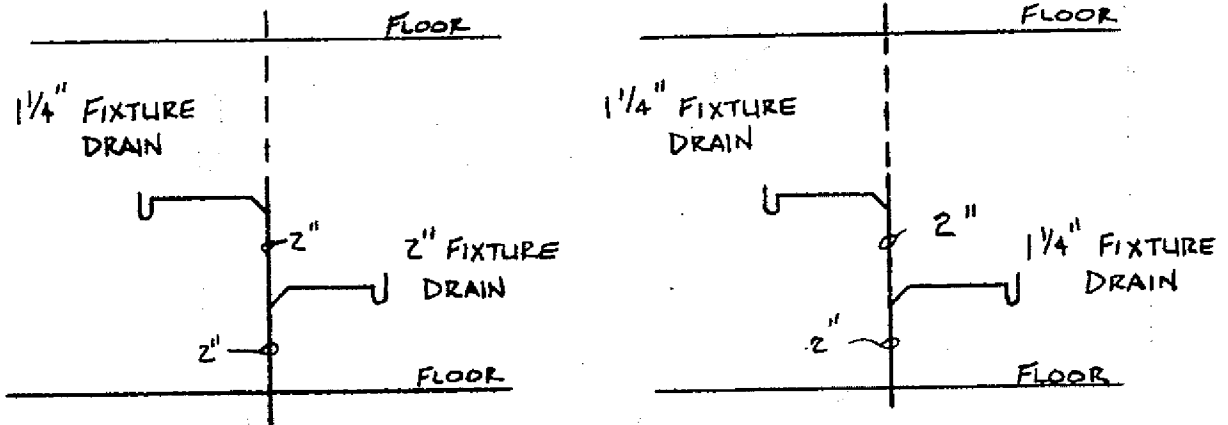

A-82.31 (13) (b) HORIZONTAL WET VENTS.

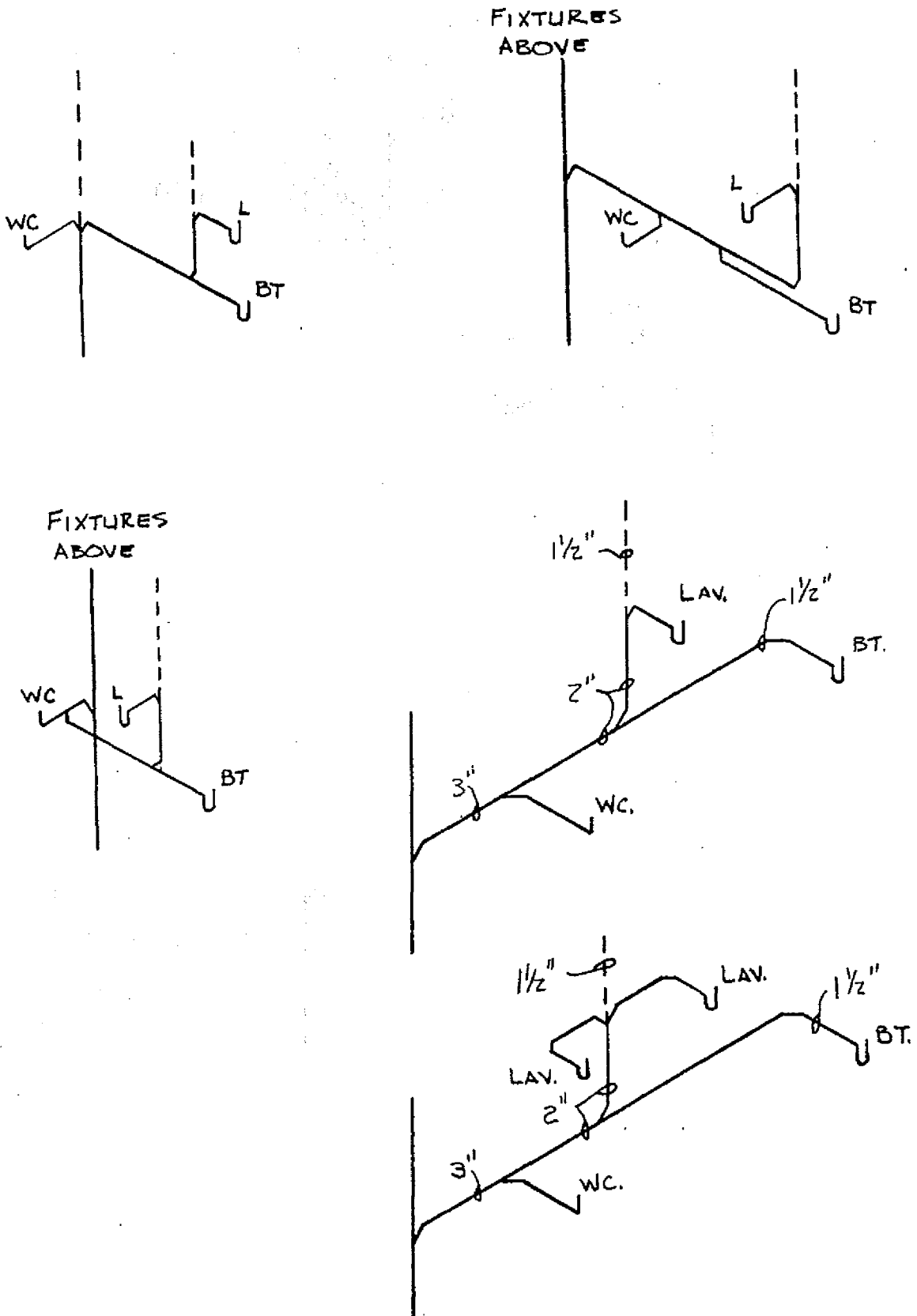

A-82.31 (13) (c) WET VENTING - FLOOR OUTLET FIXTURES.

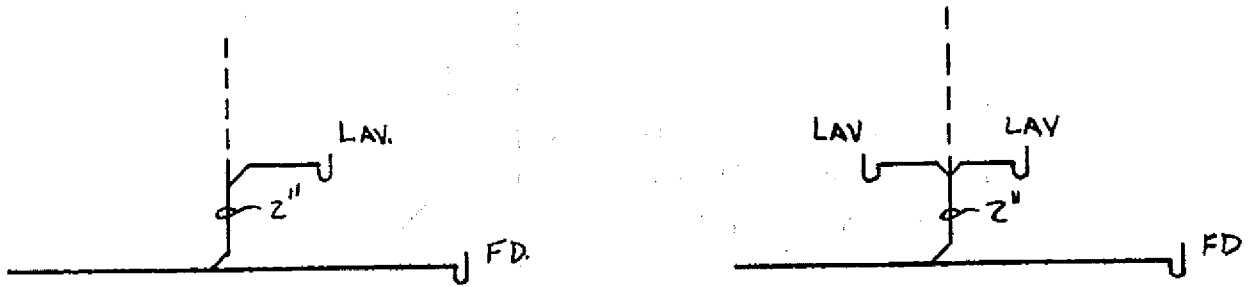

INDIVIDUAL VENT FOR FLOOR OUTLET FIXTURE
SERVING AS A WET VENT

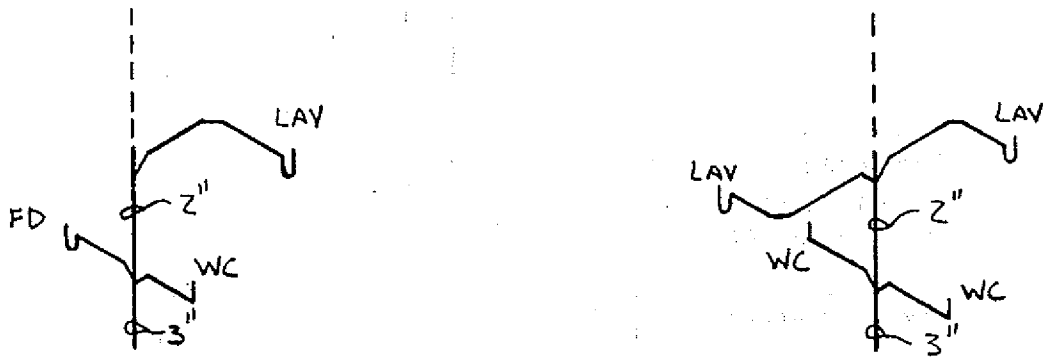

COMMON VENT FOR FLOOR OUTLET FIXTURES
SERVING AS A WET VENT

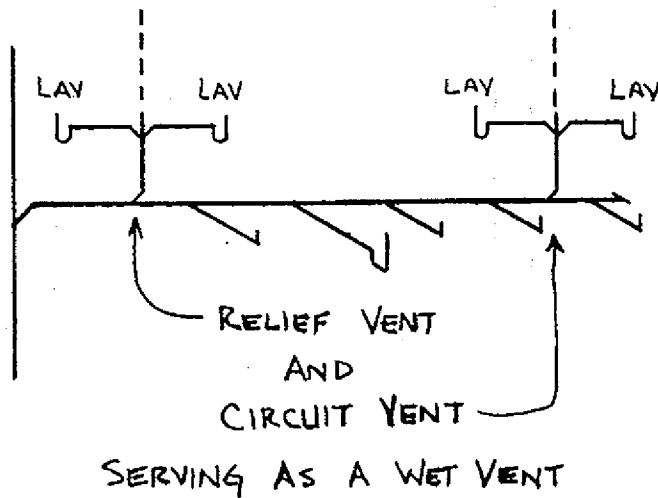

A-82.31 (14) (a) and (b) SIZING VENT STACKS AND STACK VENTS.

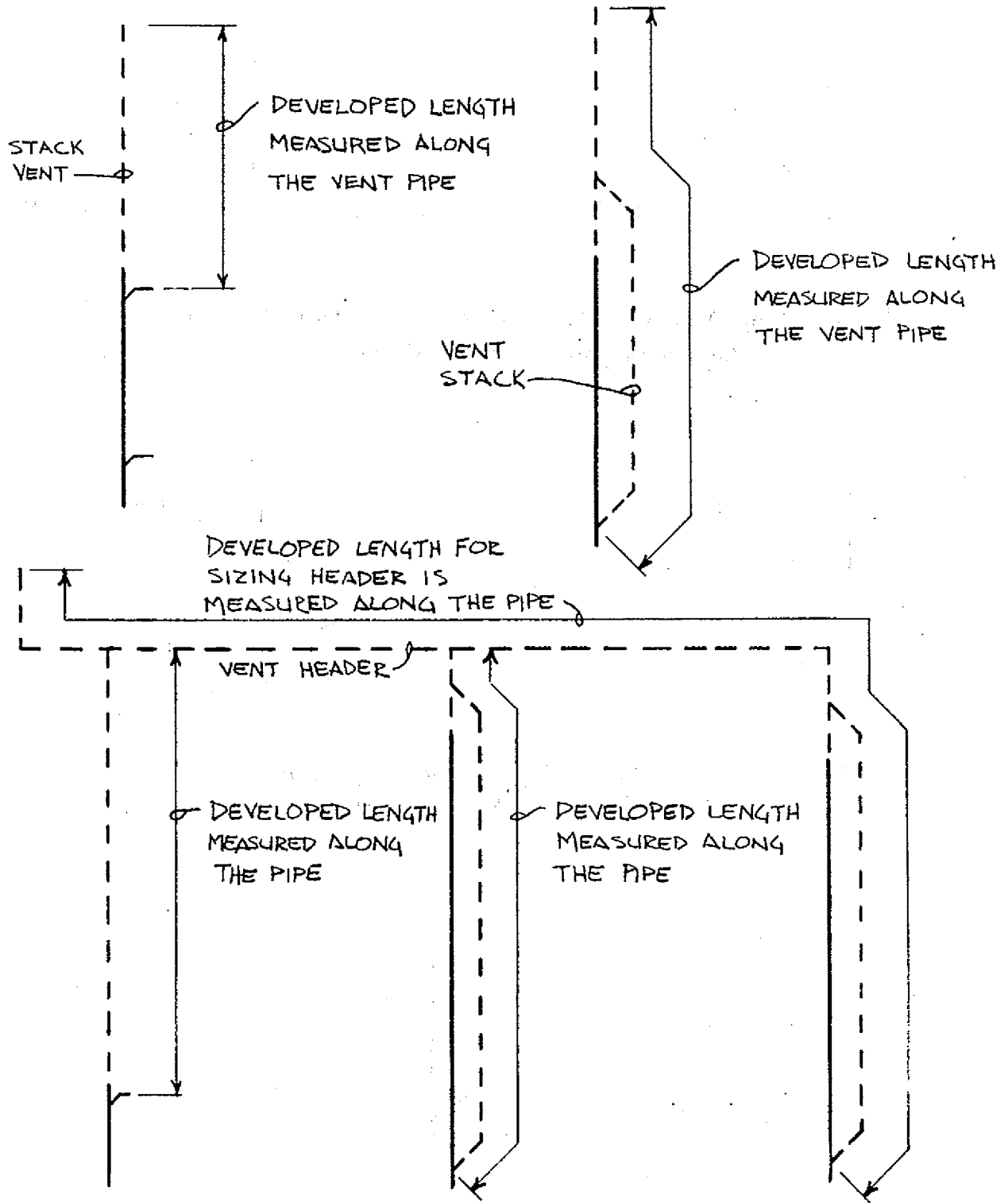

A-82.31 (14) (c) SIZING BRANCH VENTS.

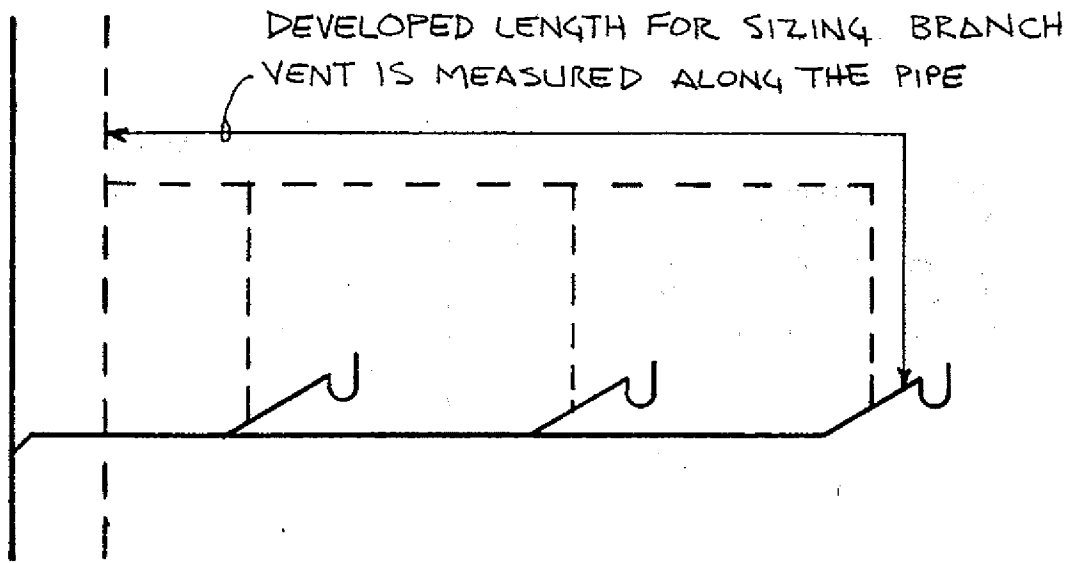

A-82.31 (14) (d) SIZING INDIVIDUAL VENTS.

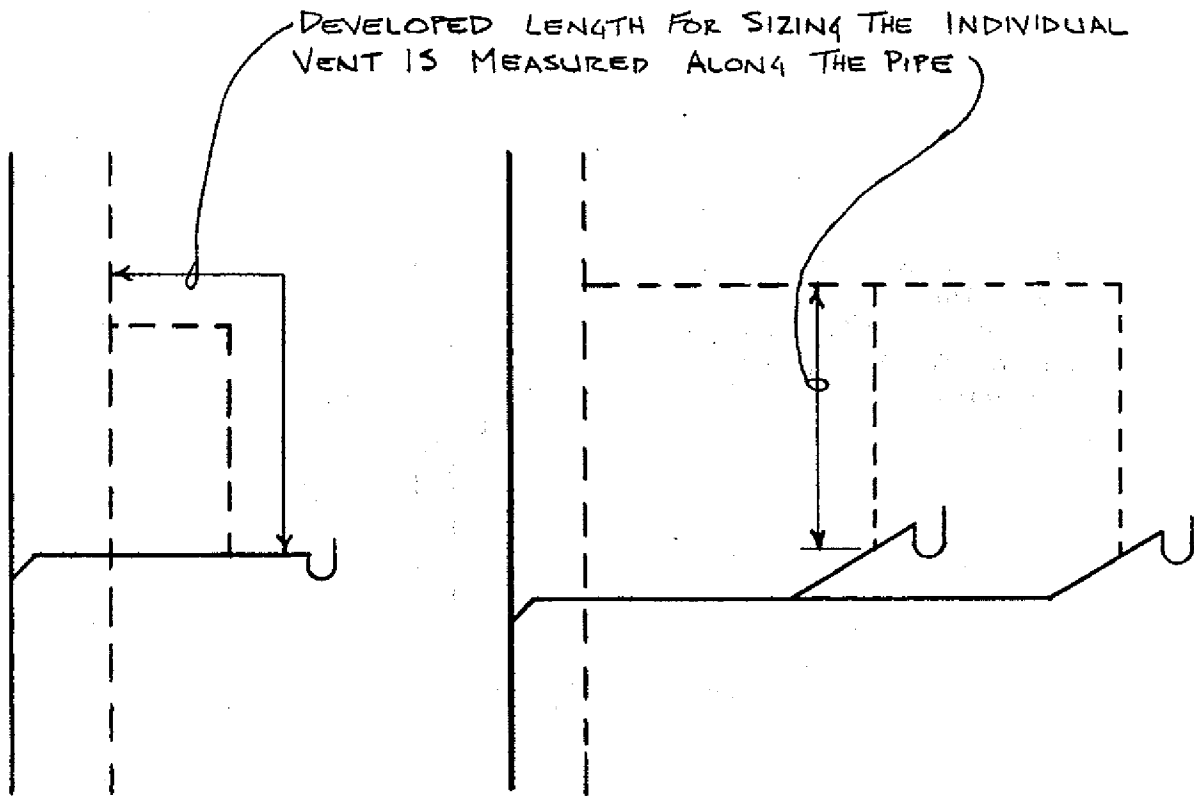

A-82.31 (14) (c) SIZING BRANCH VENTS SERVING A WET VENT.

WHEN SIZING THE BRANCH VENT, THE DEVELOPED LENGTH IS MEASURED ALONG THE VENT PIPE, INCLUDING THE WET VENT PORTION.

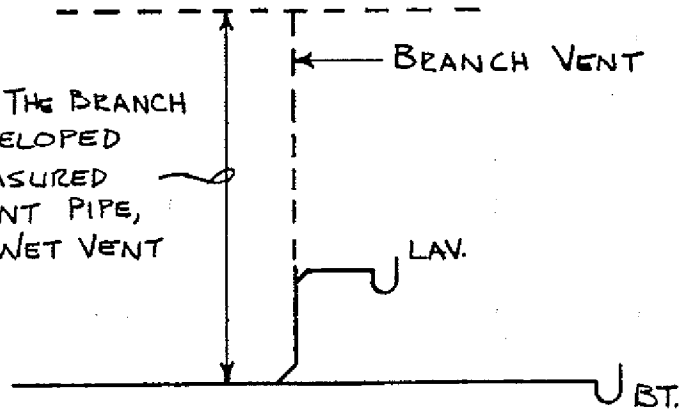

WHEN SIZING THE BRANCH VENT, THE DEVELOPED LENGTH IS MEASURED ALONG THE VENT PIPE, INCLUDING THE WET VENT PORTION.

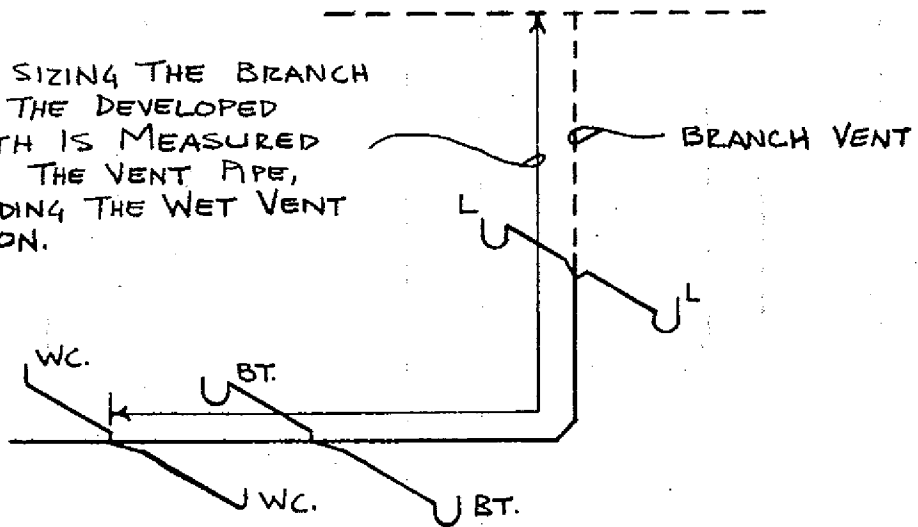

A-82.31 (15) (a) VENT GRADES AND CONNECTIONS.

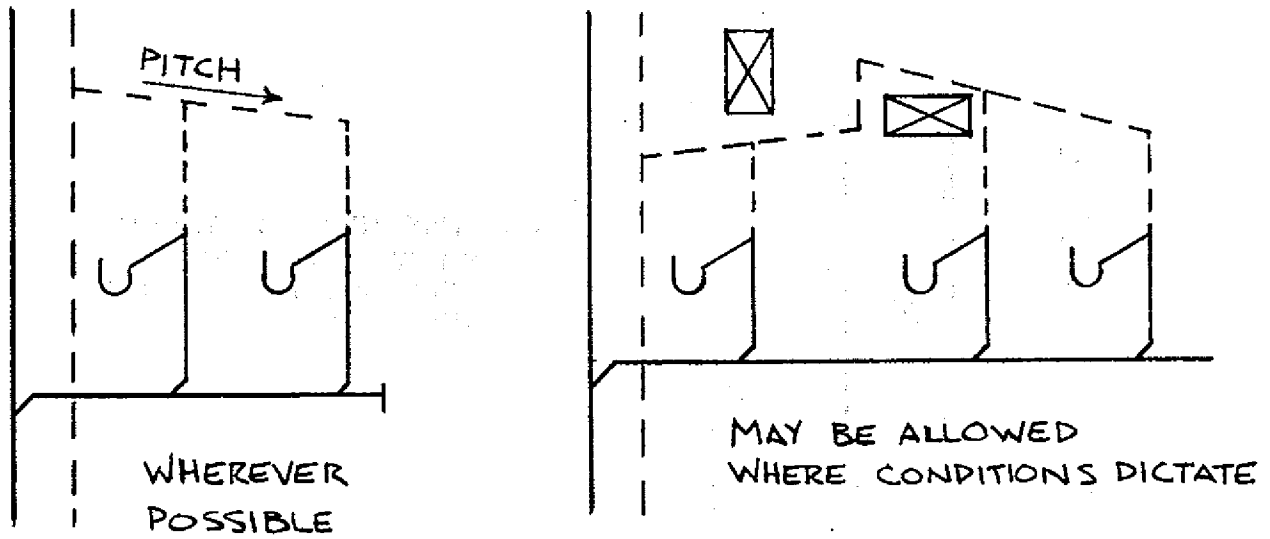

A-82.31 (15) (b) VENT GRADES AND CONNECTIONS.

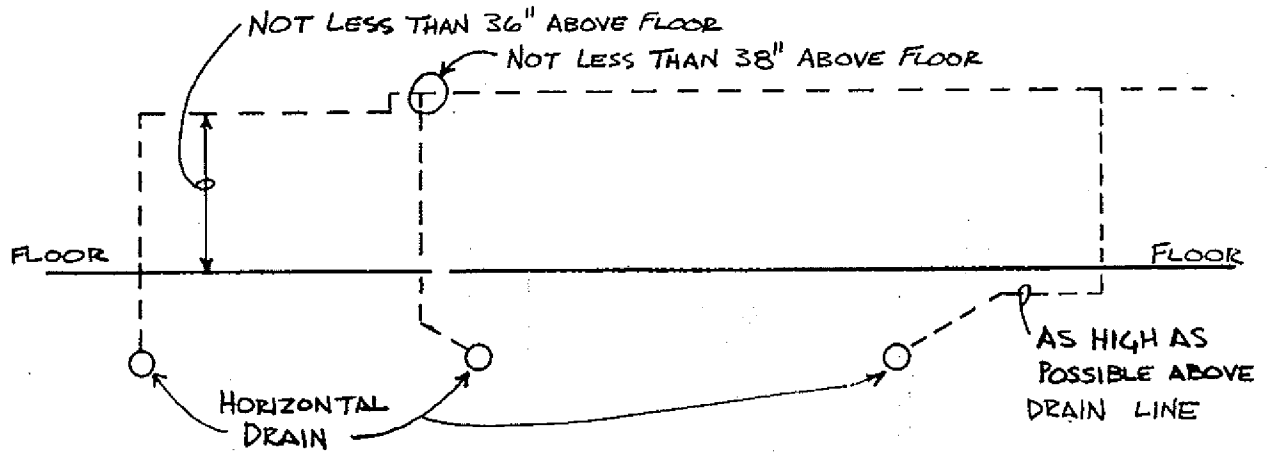

A-82.31 (16) VENT TERMINALS.

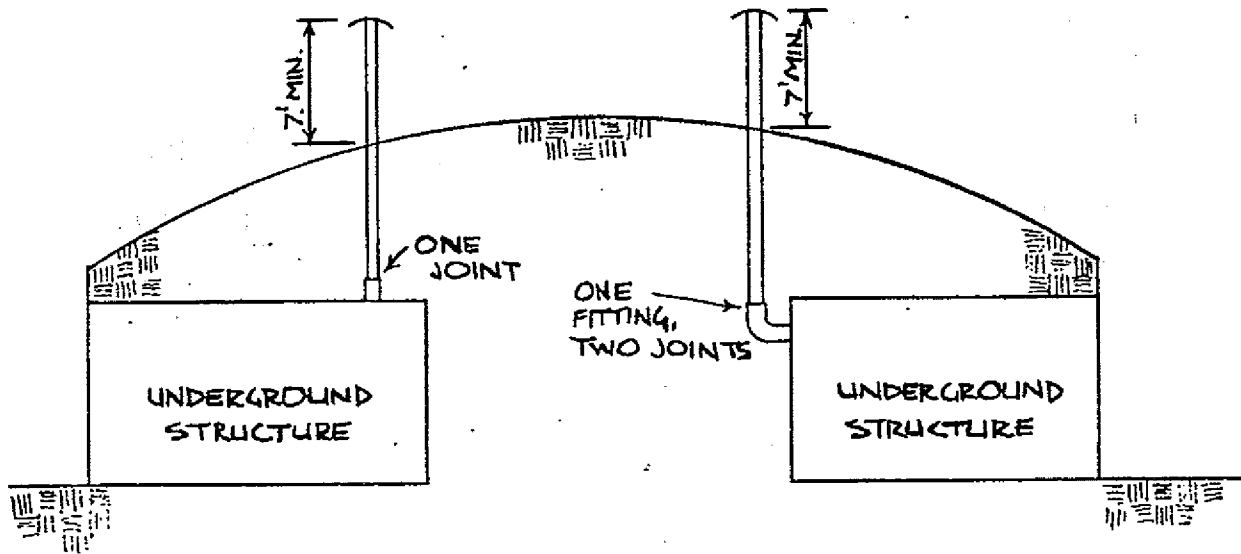
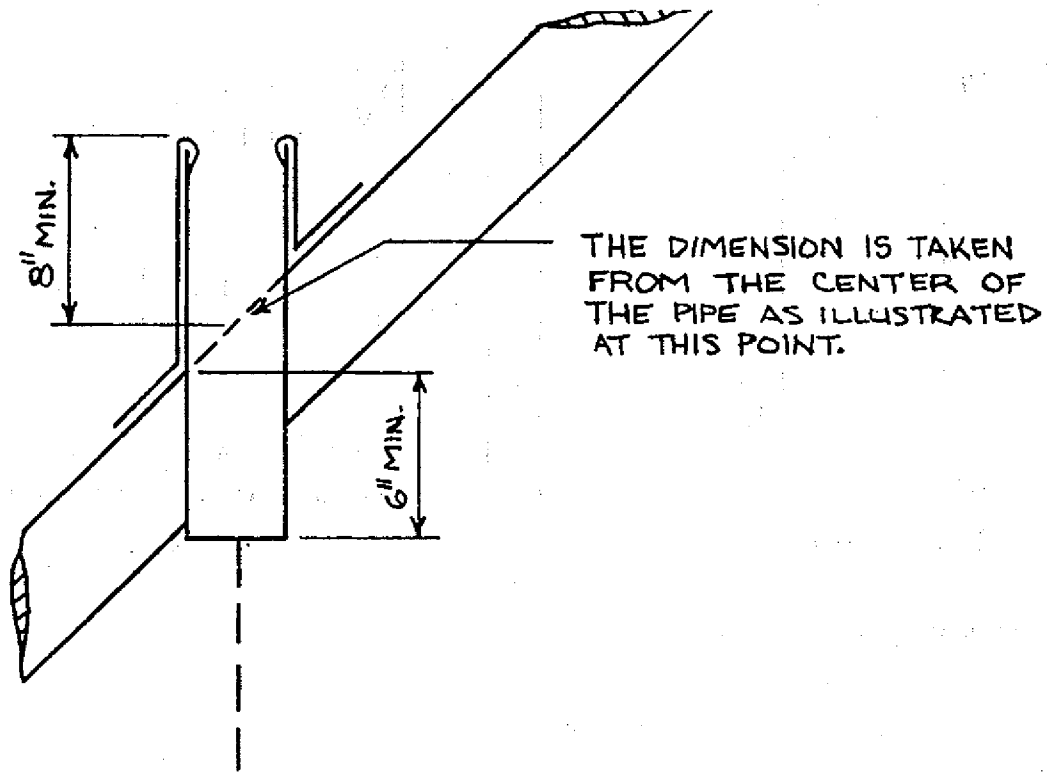

VENT TERMINALS FOR UNDERGROUND STRUCTURES

A-82.31 (17) (a) COMBINATION DRAIN AND VENT STACKS.

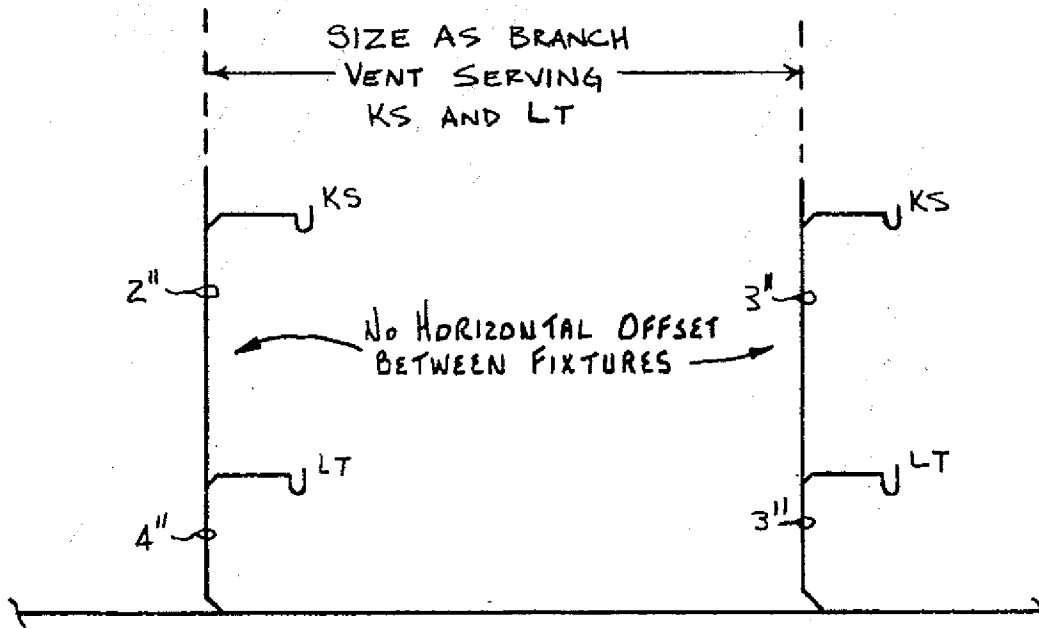
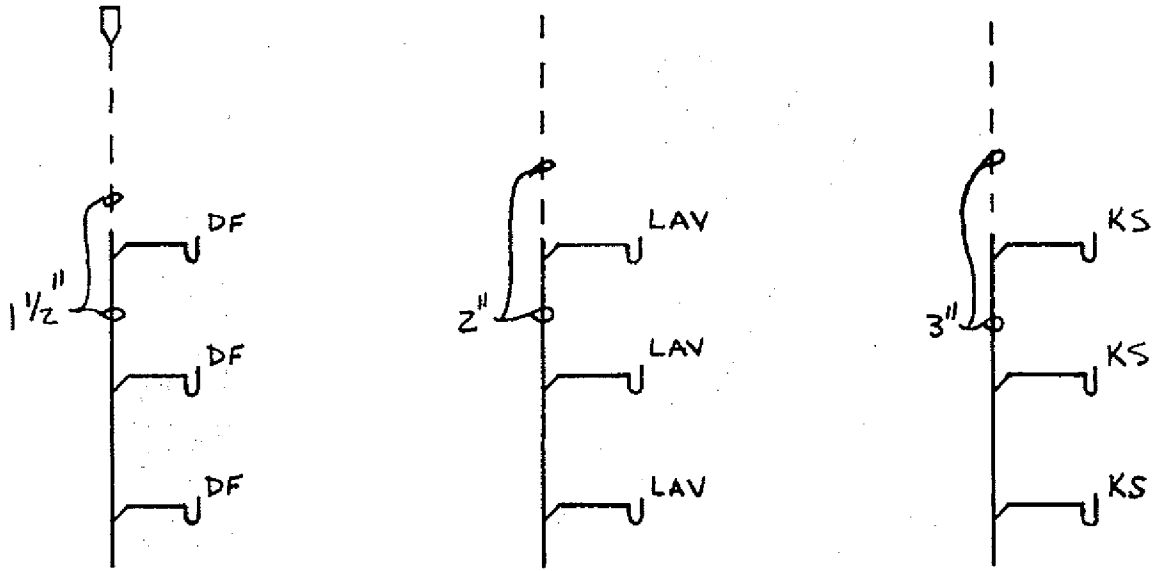

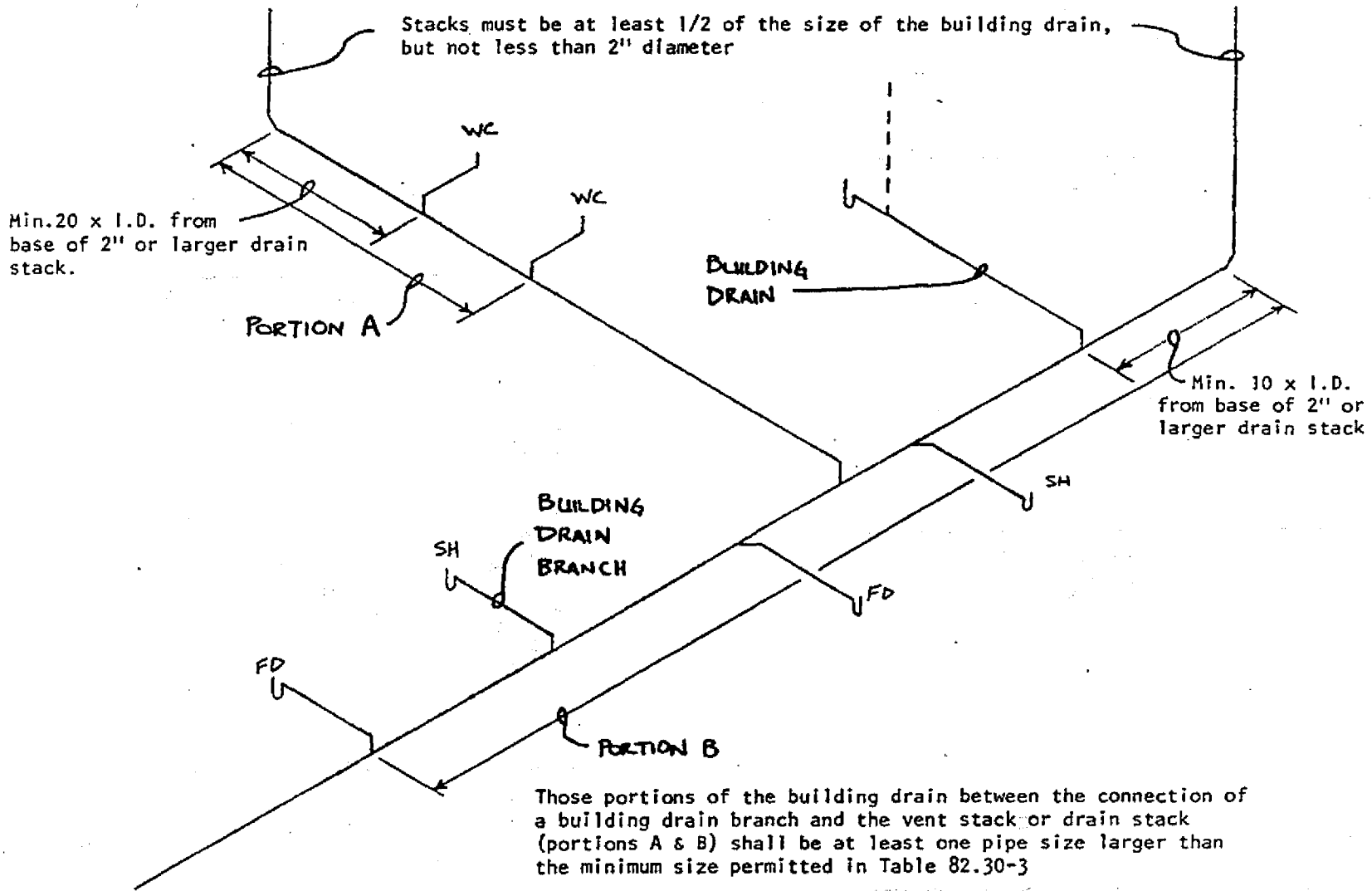

A-82.31 (17) (b) COMBINATION DRAIN AND VENT BUILDING DRAIN.

A-82.31 (17) (c) COMBINATION DRAIN AND VENT LABORATORY SINK VENTING.

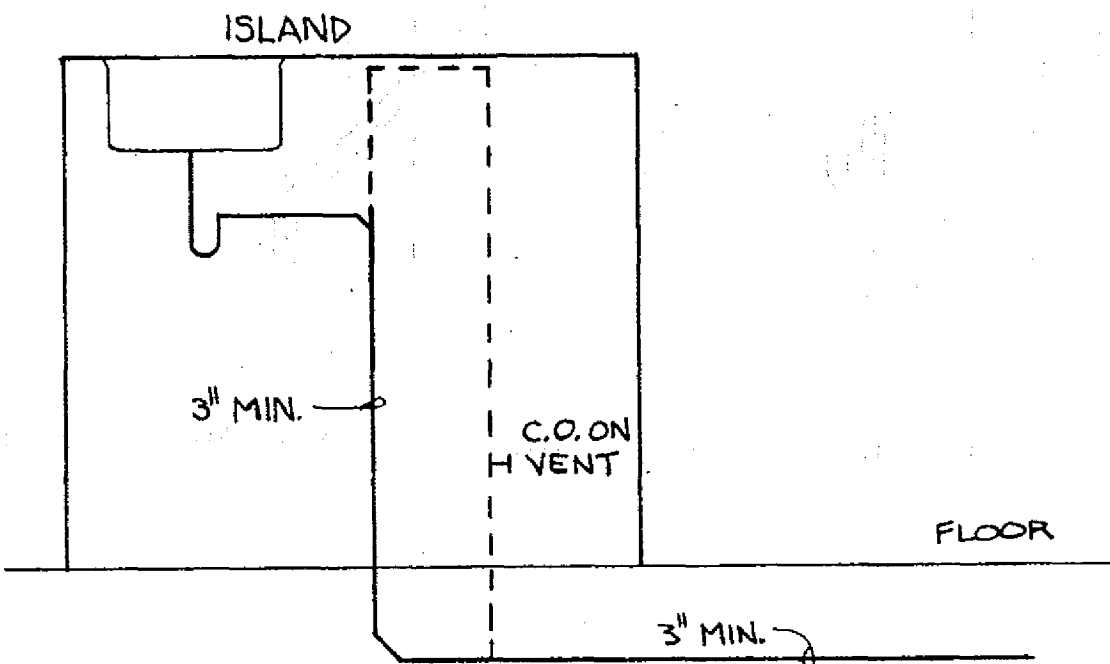
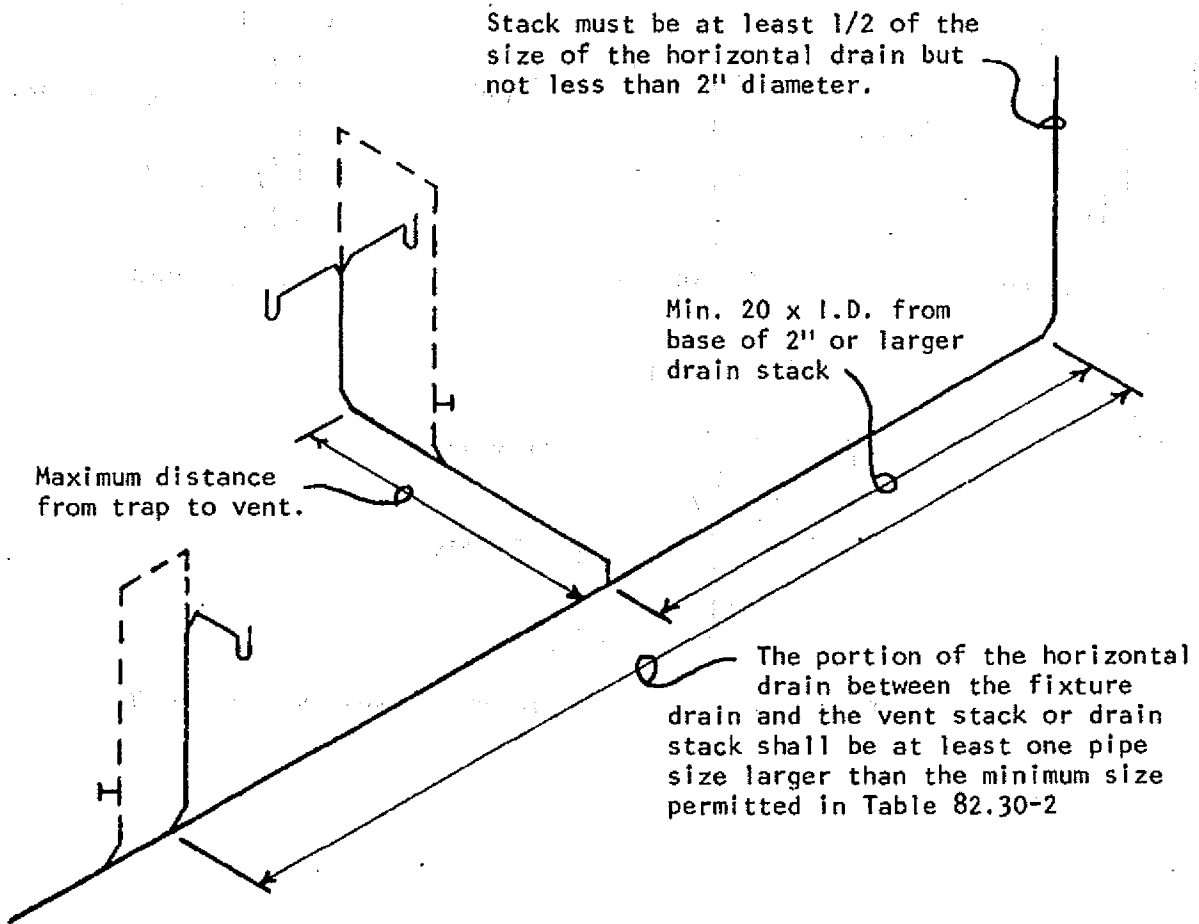

A-82.32 (4) (b) INSTALLATION OF TRAPS.

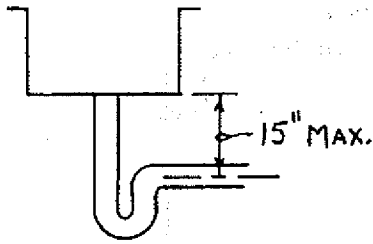

MOST FIXTURES

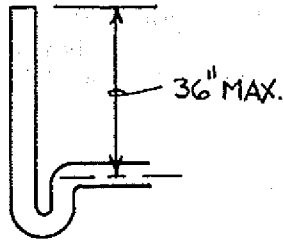

STANDPIPE

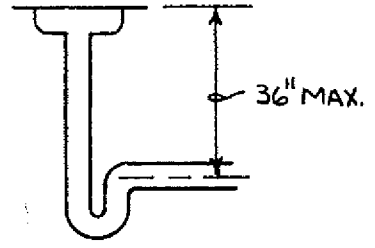

FLOOR DRAIN

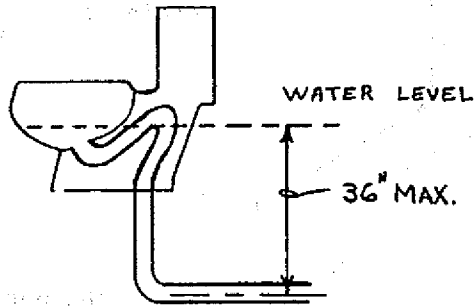

VERTICAL DISTANCE BETWEEN FIXTURE DRAIN OUTLET AND TRAP

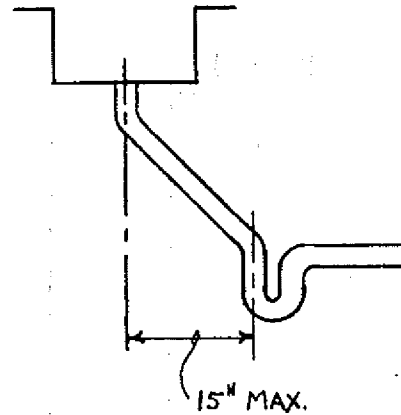
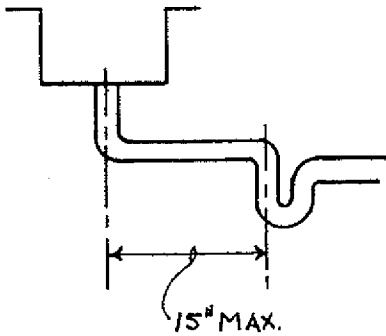

HORIZONTAL DISTANCE BETWEEN FIXTURE DRAIN OUTLET AND TRAP

A-82.33 (6) INDIRECT AND LOCAL WASTE PIPING.

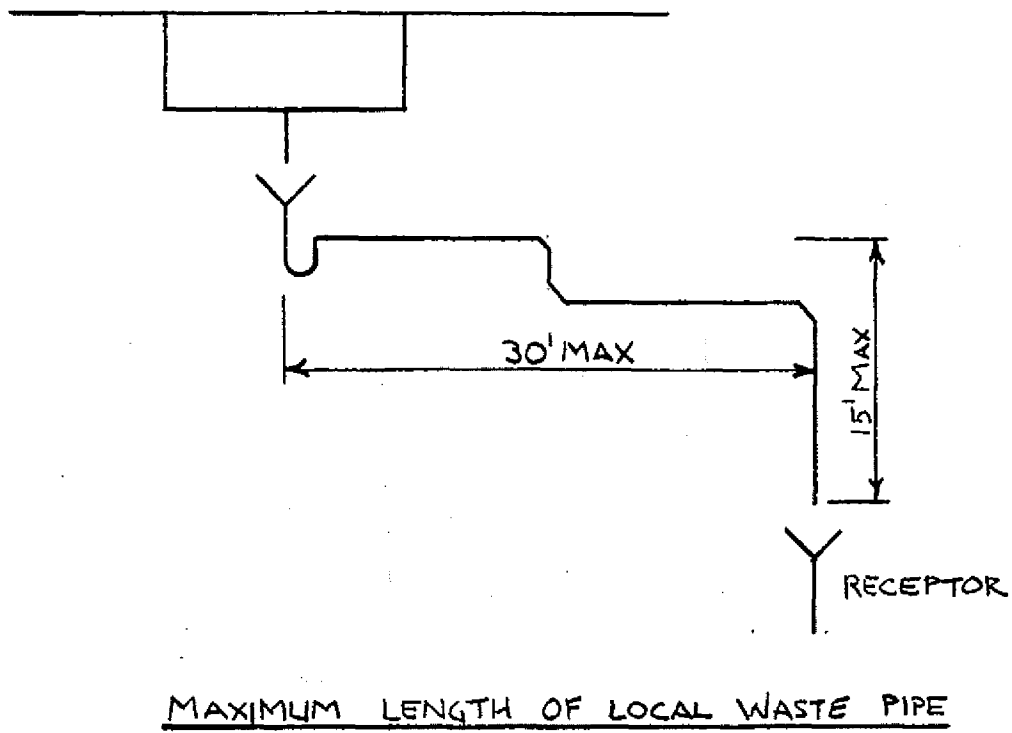
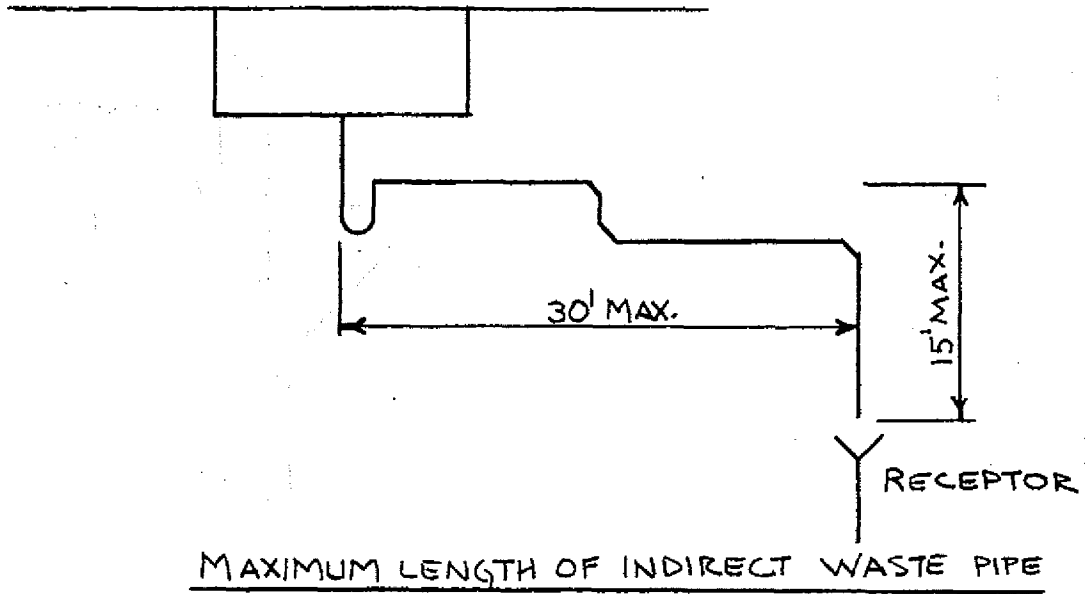

A-82.33 (7) AIR-GAPS AND AIR-BREAKS.

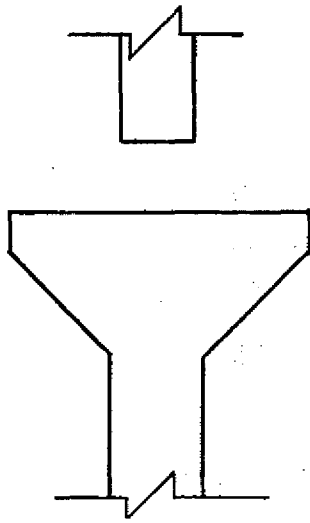

AIR GAP

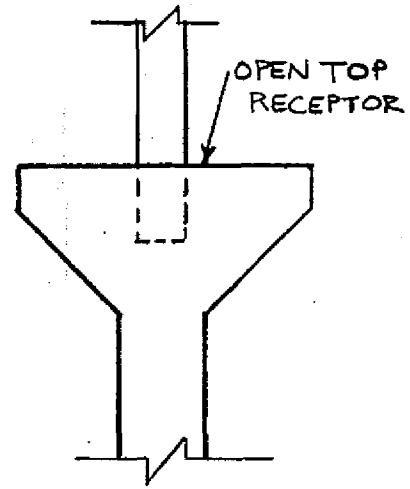

AIR BREAK

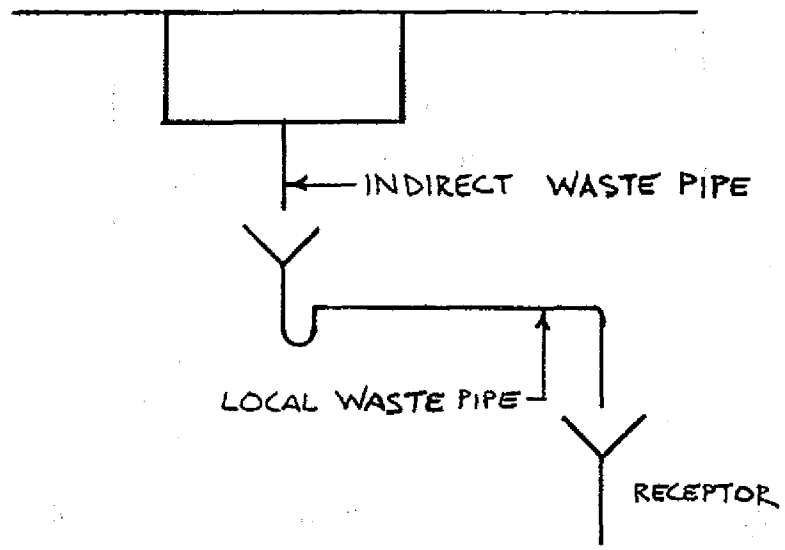

A-82.33 (8) (a) WASTE SINKS AND STANDPIPES.

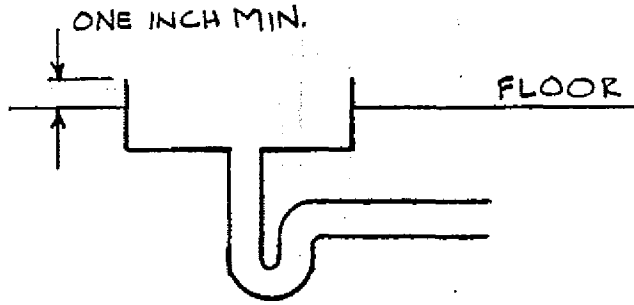

WASTE SINK IN FLOOR

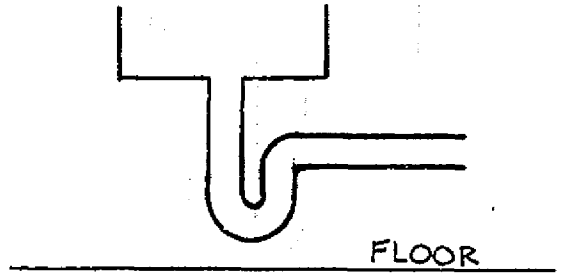

WASTE SINK ABOVE FLOOR

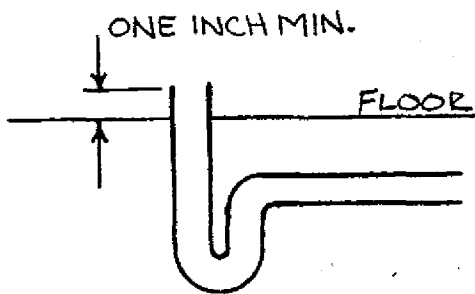

STANDPIPE IN FLOOR

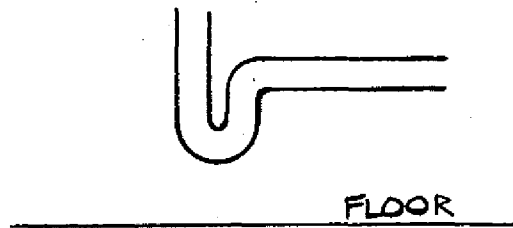

STANDPIPE ABOVE FLOOR

A-82.33 (8) (b) FLOOR SINKS.

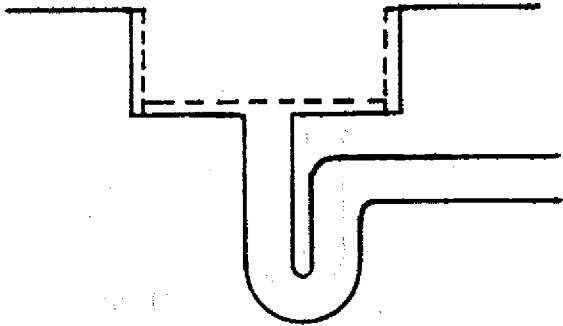

FLOOR SINK WITH BASKET

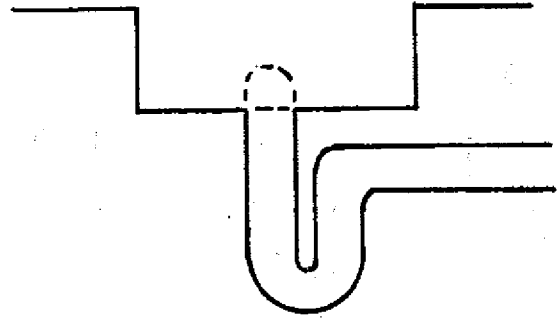

FLOOR SINK WITH DOME STRAINER

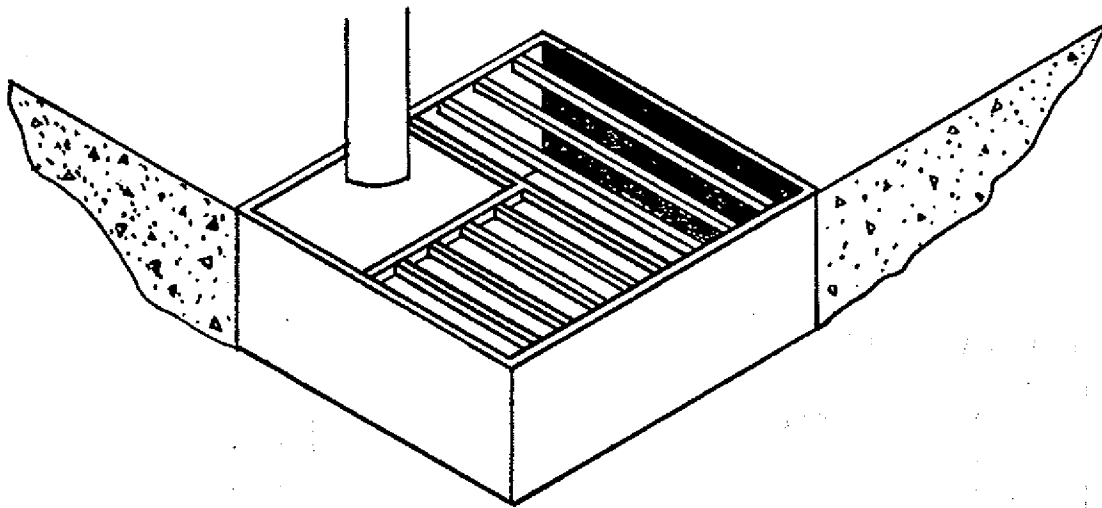

FLOOR SINK WITH GRATE OPENING
FOR AIR GAP

A-82.33 (8) (c) LOCAL WASTE PIPING.

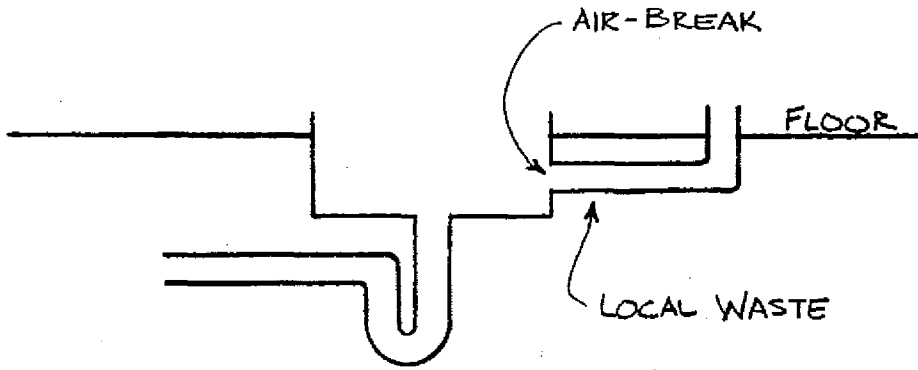

LOCAL WASTE LEADING TO A WASTE SINK,
FLOOR SINK OR FLOOR DRAIN

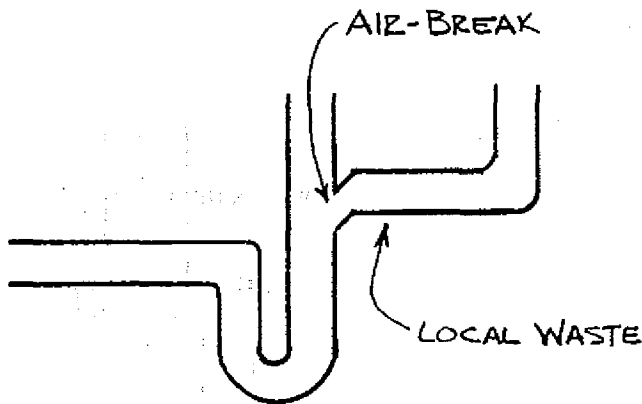

LOCAL WASTE LEADING TO A STANDPIPE

A-82.33 (8) (c) LOCAL WASTE PIPING SERVING WATER HEATER RELIEF VALVES.

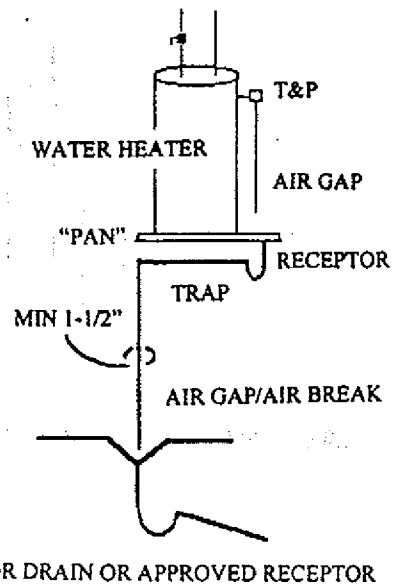
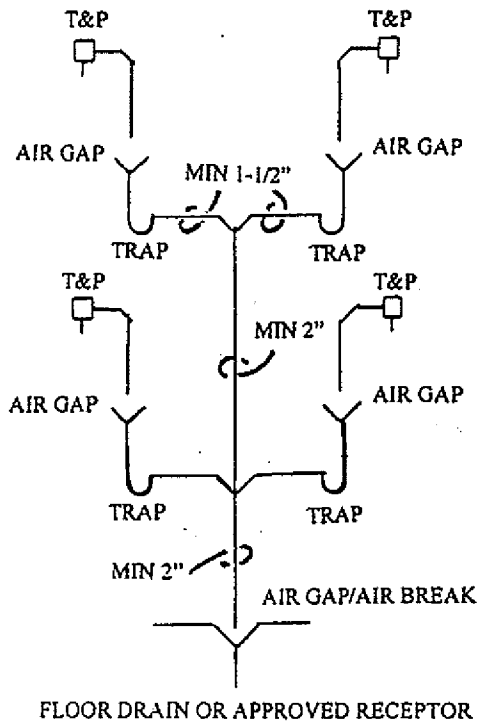
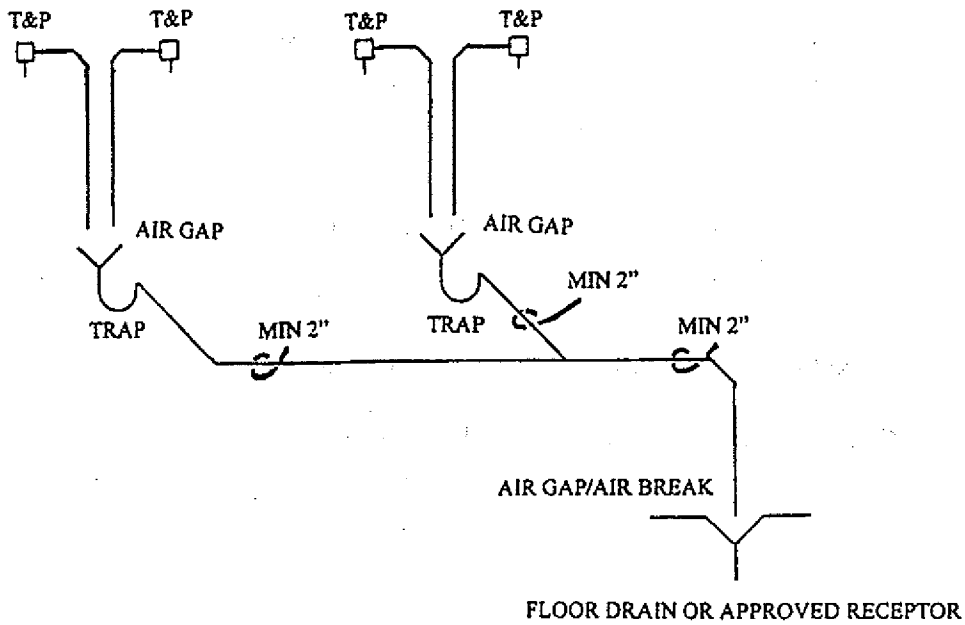

A-82.33 (9) (c) COMMERCIAL GRAVITY DISCHARGE-TYPE CLOTHES WASHERS.

TRENCH TYPE LAUNDRY RECEPTOR

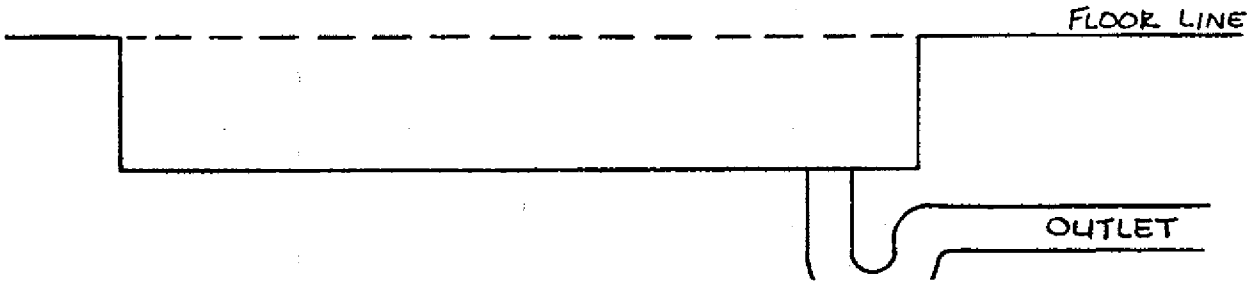

A-82.33 (9) (d) RESIDENTIAL-TYPE DISHWASHERS.

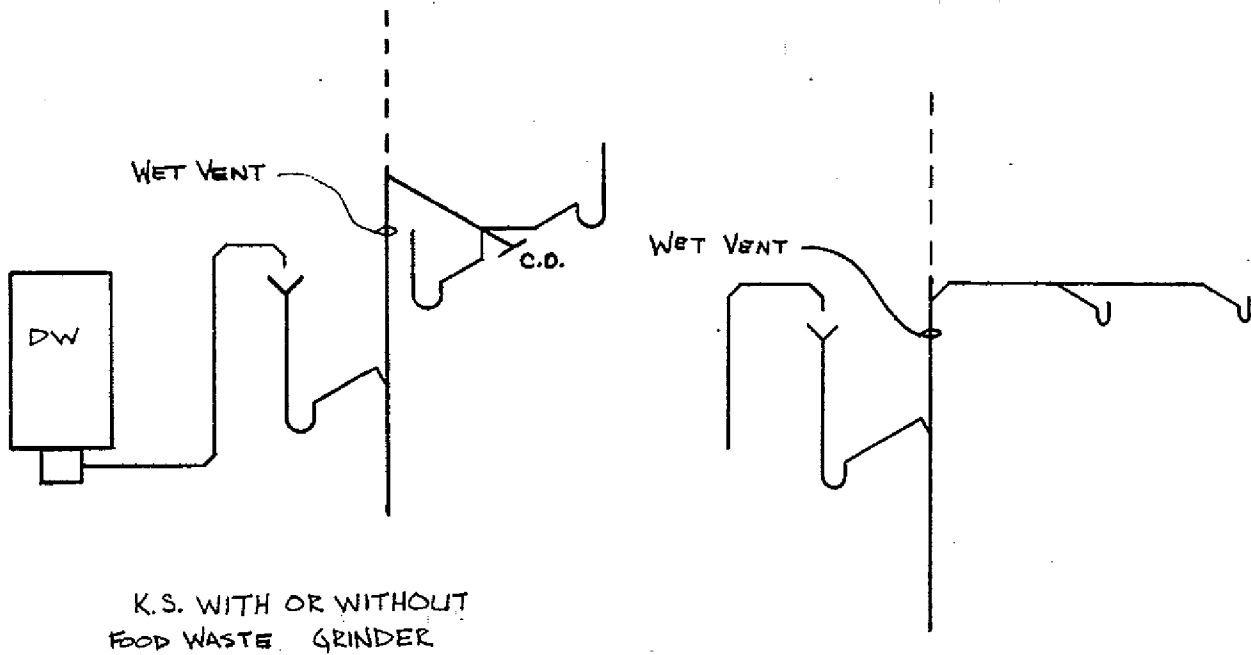

K.S. WITH OR WITHOUT
FOOD WASTE GRINDER

K.S. WITH OR WITHOUT
FOOD WASTE GRINDER

DISWASHER DISCHARGING TO A STANDPIPE
BELOW THE COUNTER TOP.

A-82.33 (9) (d) RESIDENTIAL-TYPE DISHWASHERS.

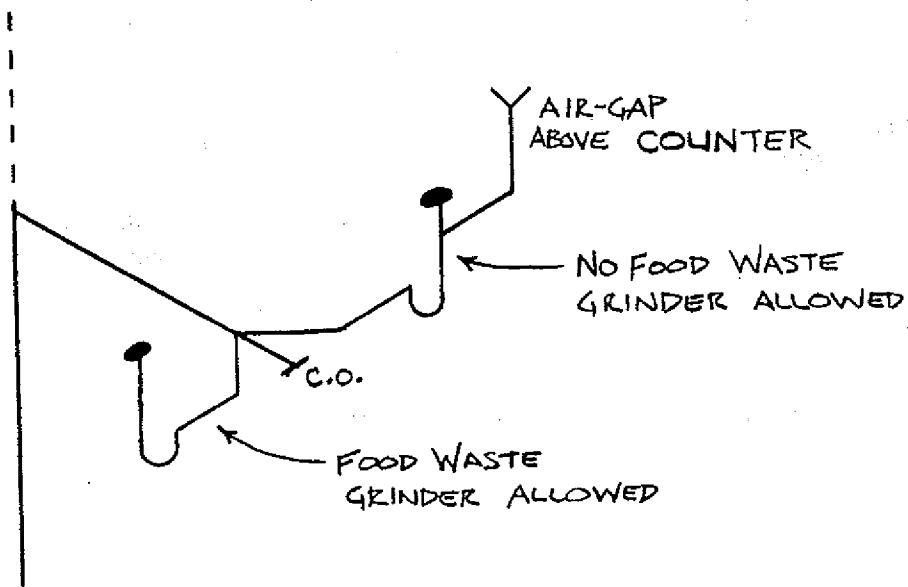
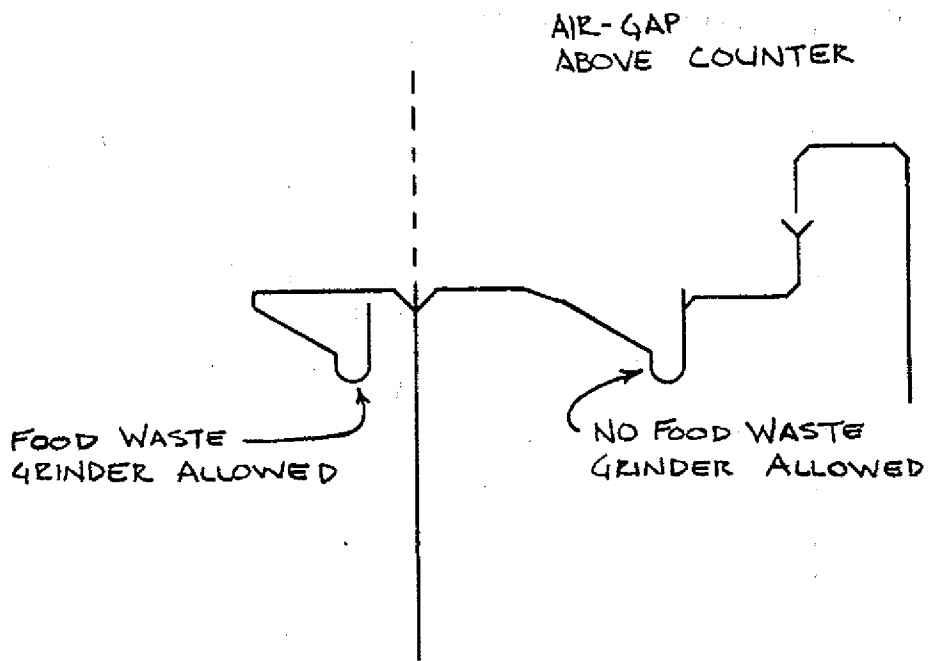

A-82.33 (9) (d) RESIDENTIAL-TYPE DISHWASHERS.

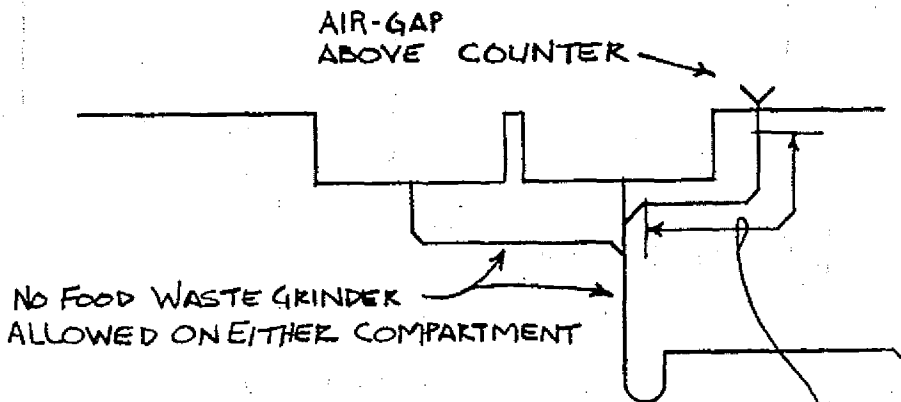
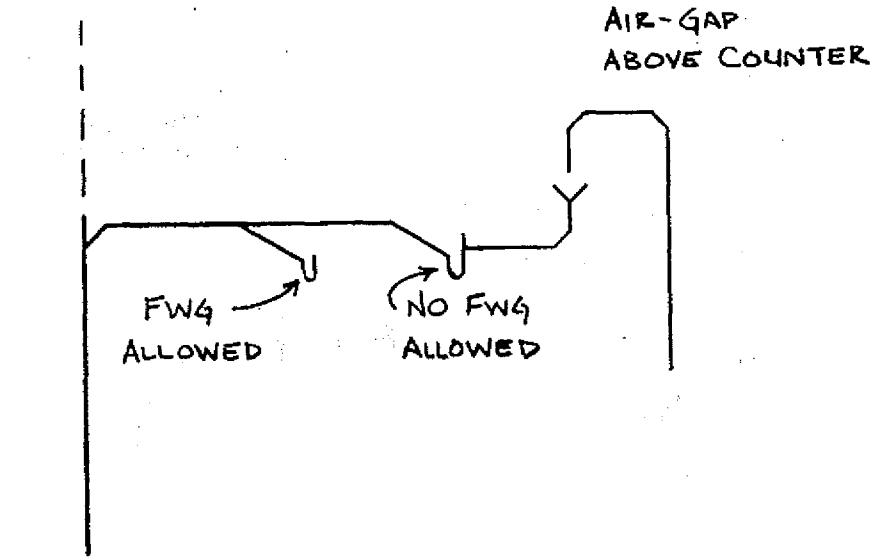

WHERE HOSE IS USED FOR LOCAL WASTE PIPING THE DEVELOPED LENGTH OF HOSE SHALL NOT EXCEED 18 INCHES

A-82.33 (9) (d) COMMERCIAL DISHWASHERS.

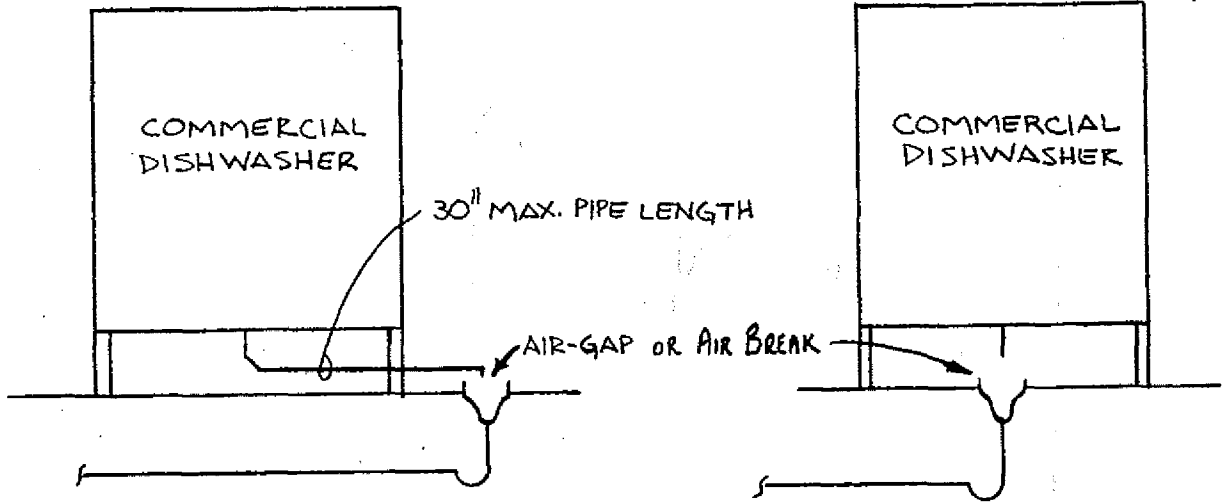

A-82.33 (9) (f) ELEVATOR PIT SUBSOIL AND FLOOR DRAINS.

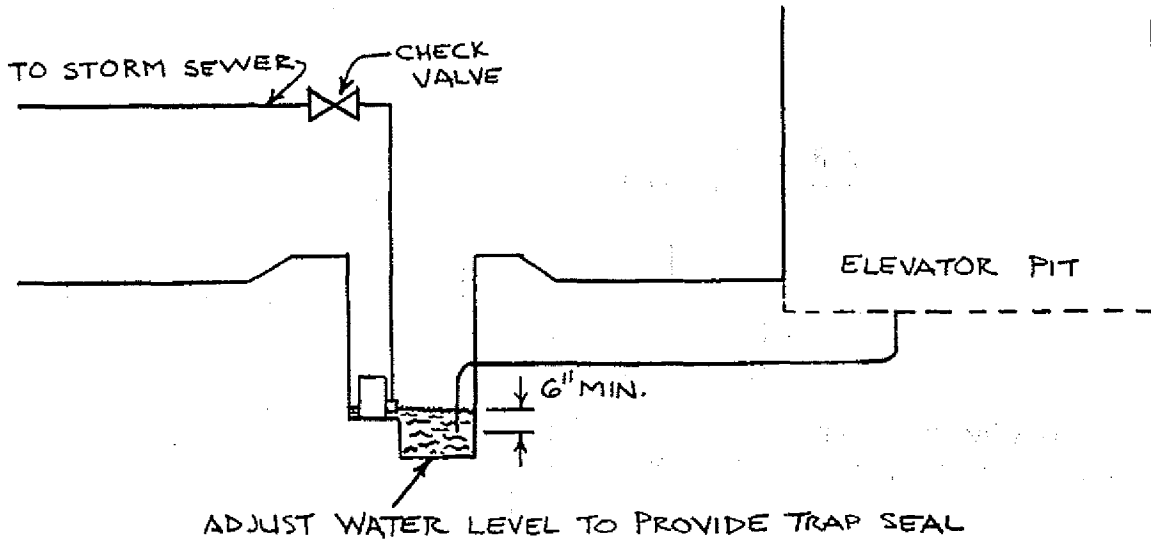

A-82.33 (9) (g) 1. BAR AND SODA FOUNTAIN SINKS.

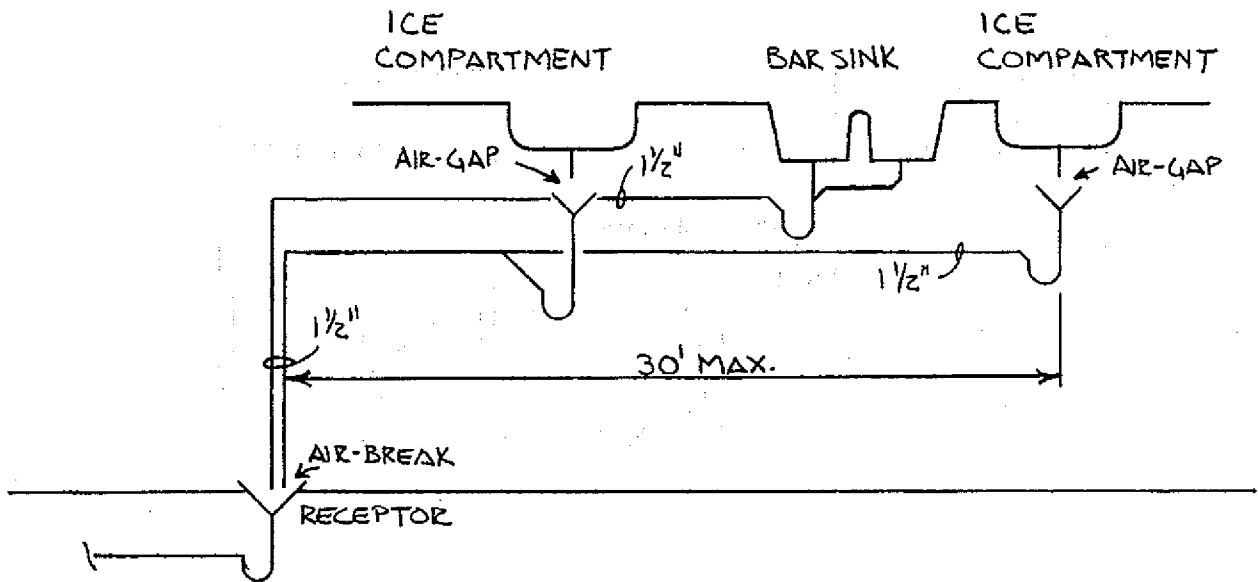

A-82.33 (9) (g) 2. BEER TAPS, COFFEE MAKERS, GLASS FILLERS AND SODA DISPENSERS.

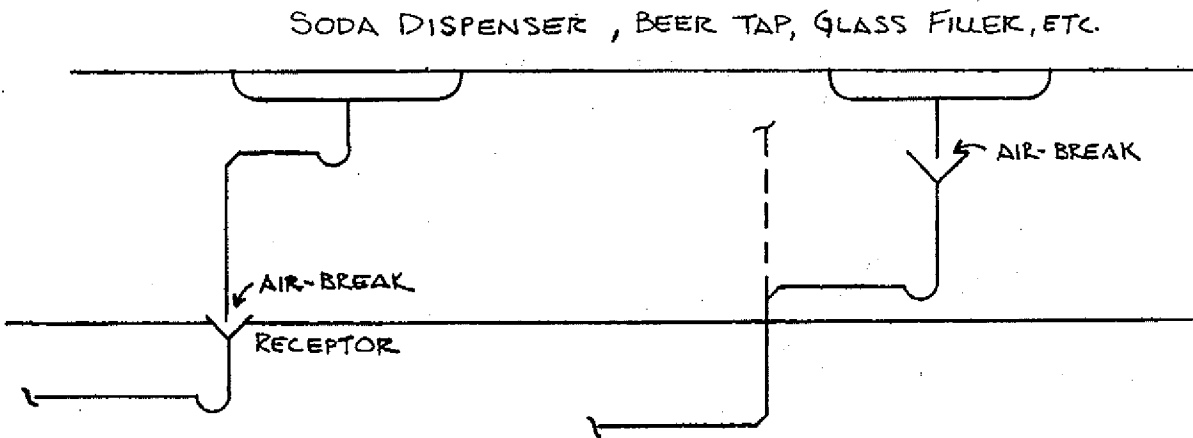

A-82.33 (9) (g) 3. NOVELTY BOXES, AND ICE COMPARTMENTS AND ICE CREAM DIPPER WELLS.

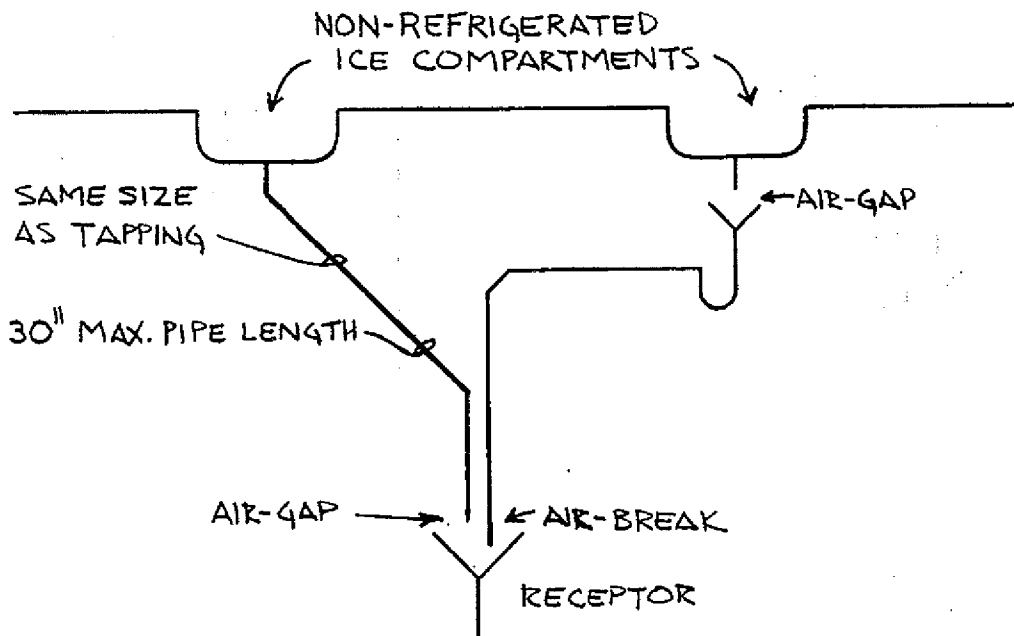
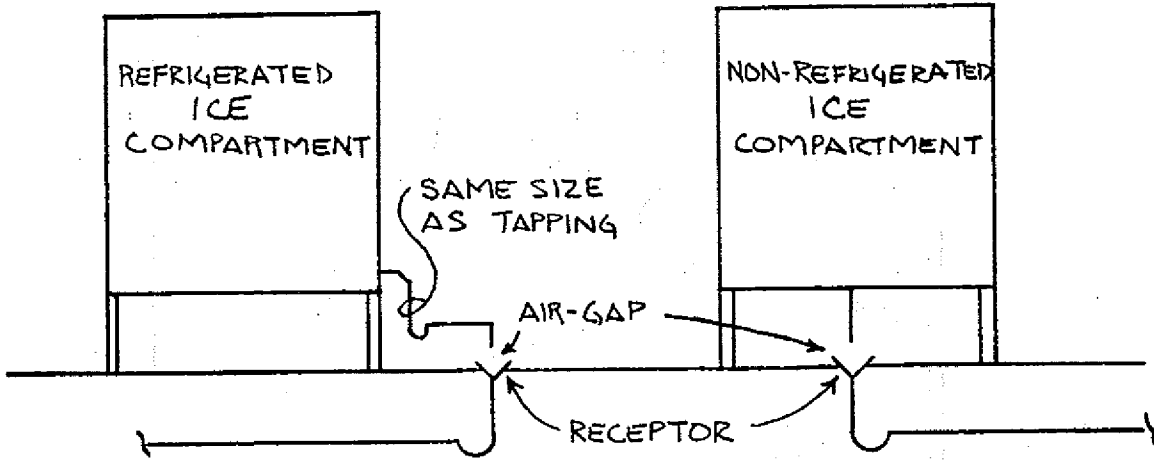

A-82.33 (9) (g) 4. REFRIGERATED FOOD STORAGE ROOMS, COMPARTMENTS, AND DISPLAY CASES.

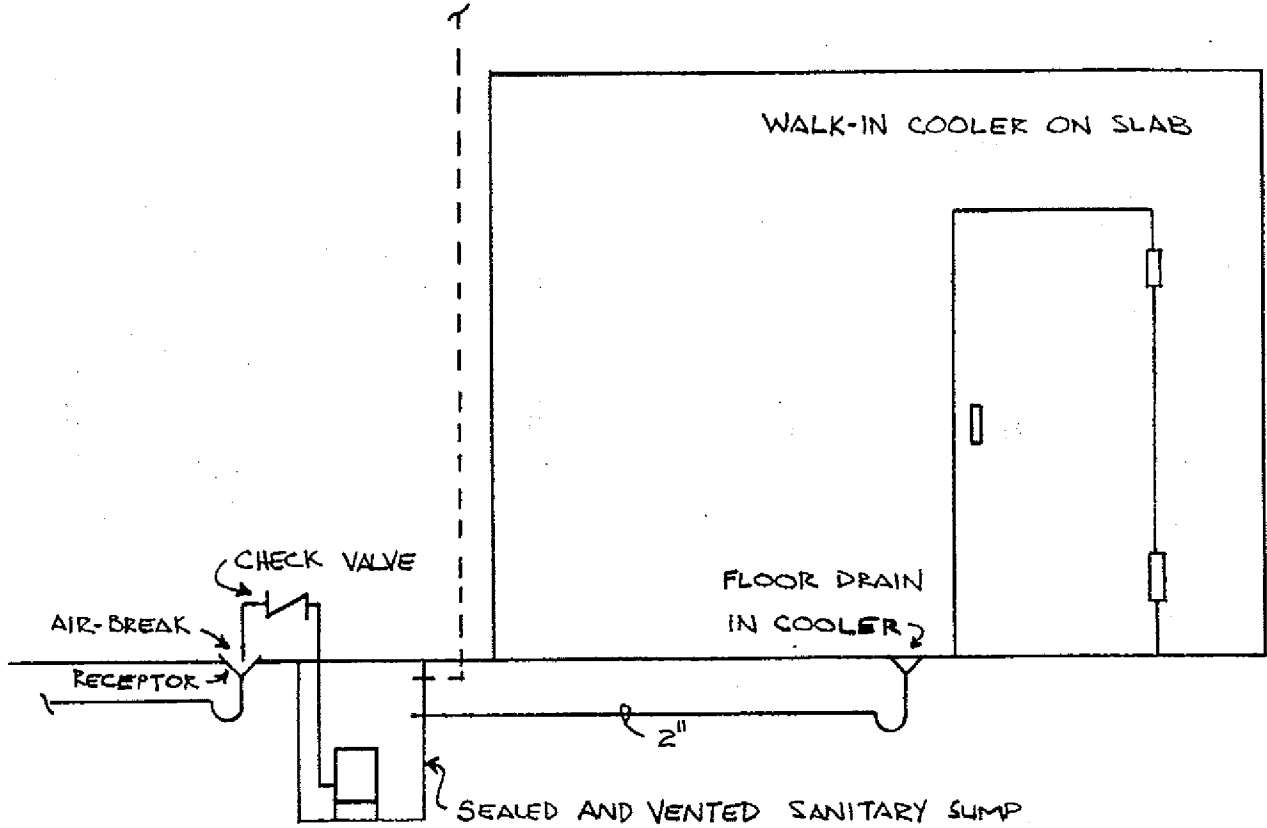
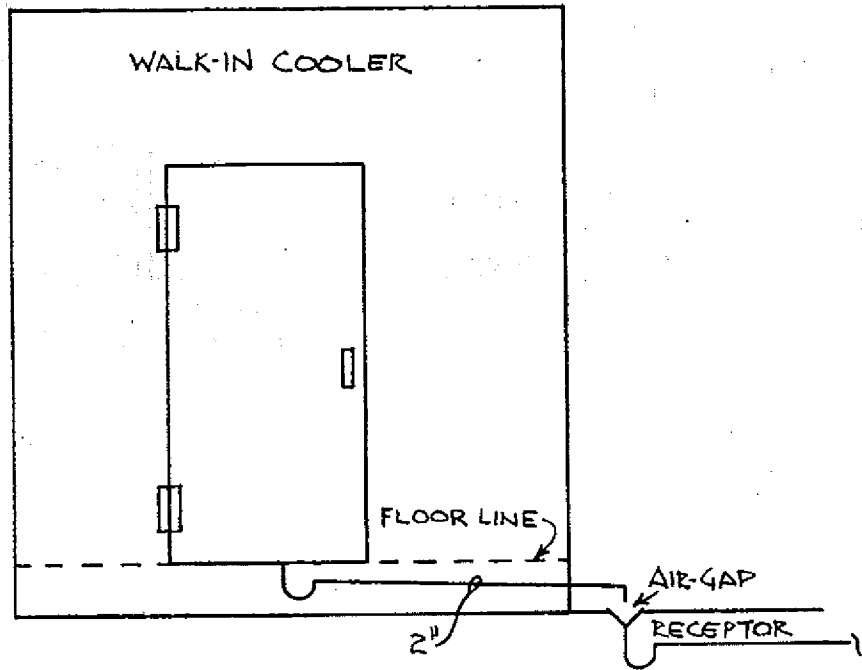

A-82.33 (9) (g) 5. MISCELLANEOUS FOOD HANDLING EQUIPMENT.

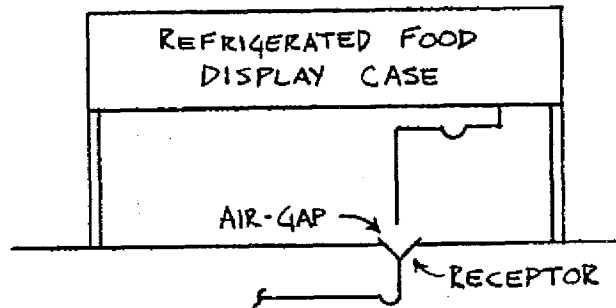
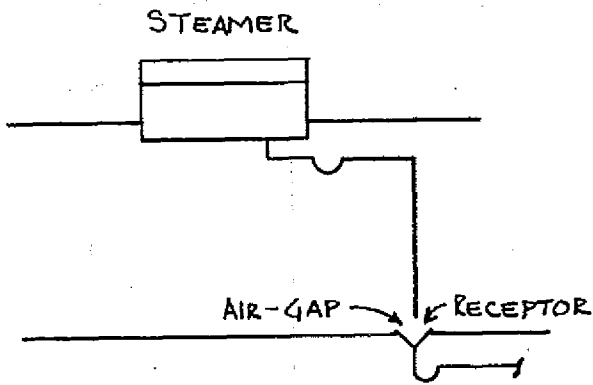
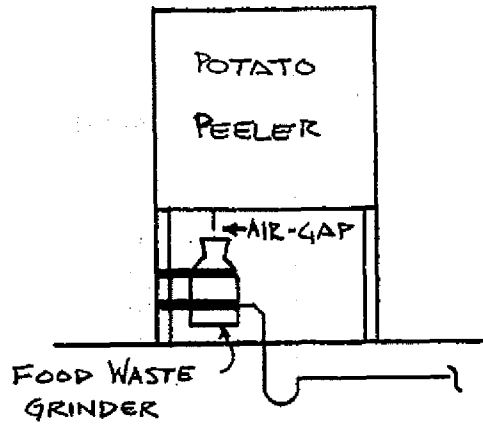
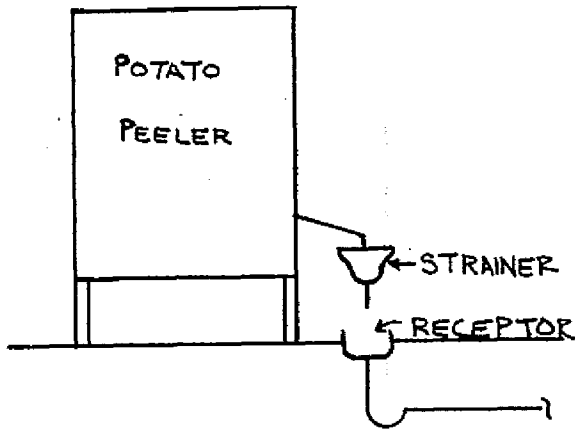

A-82.33 (9) (g) 5. MISCELLANEOUS FOOD HANDLING EQUIPMENT.

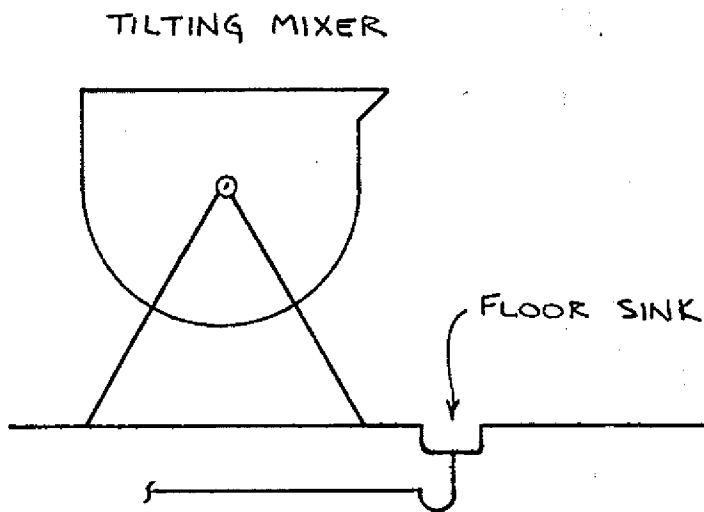
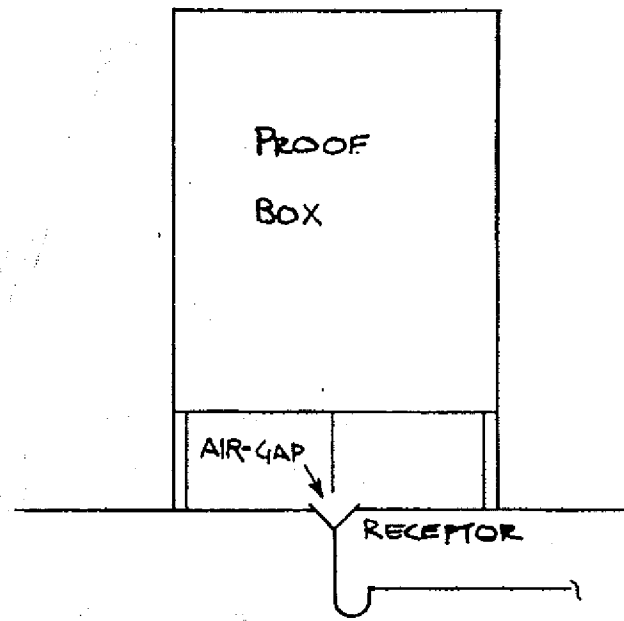

A-82.33 (9) (g) 5. MISCELLANEOUS FOOD HANDLING EQUIPMENT.

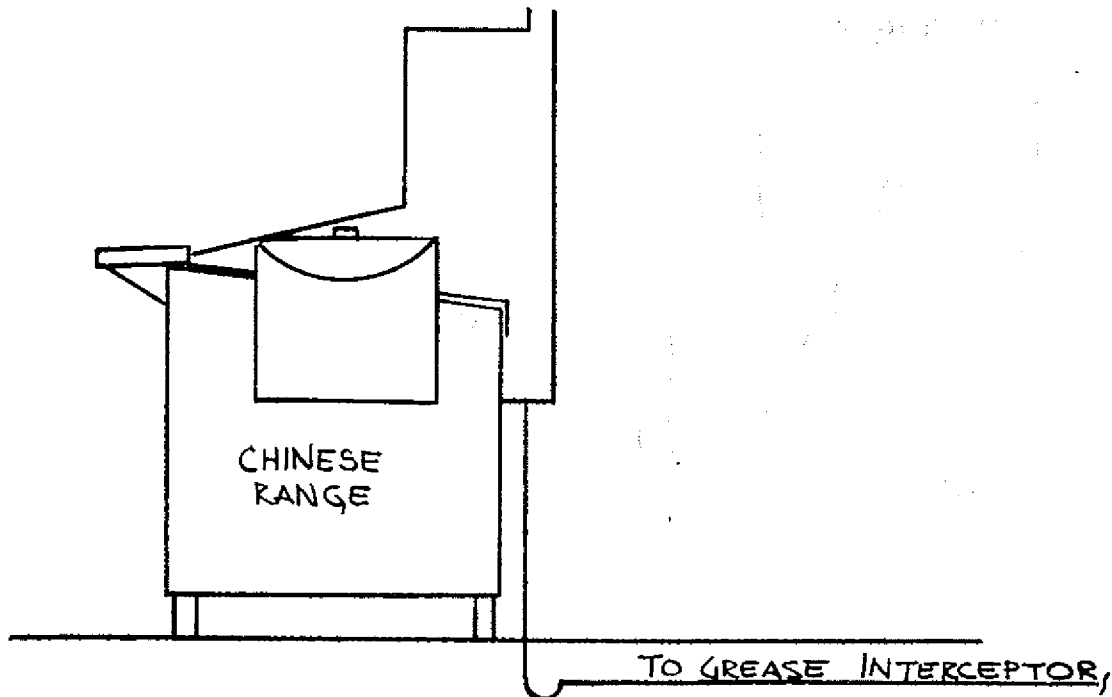
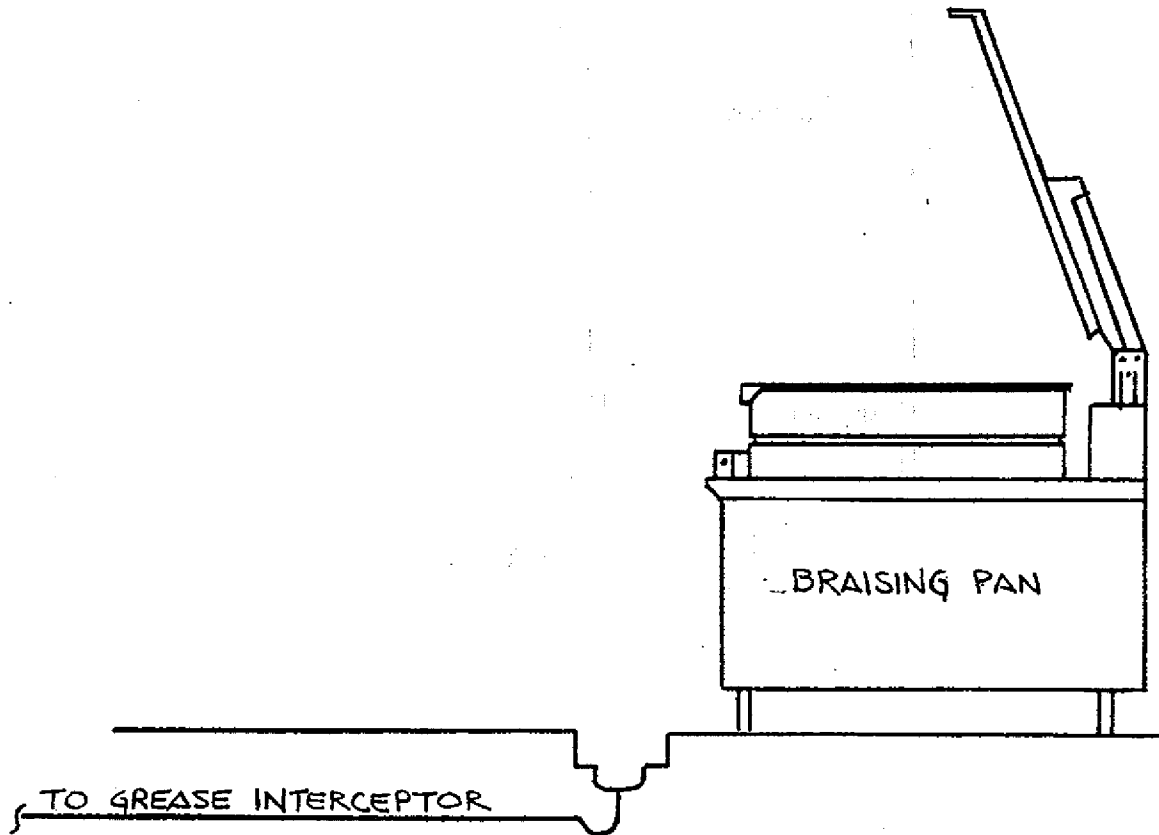

A-82.33 (9) (g) 5. MISCELLANEOUS FOOD HANDLING EQUIPMENT.

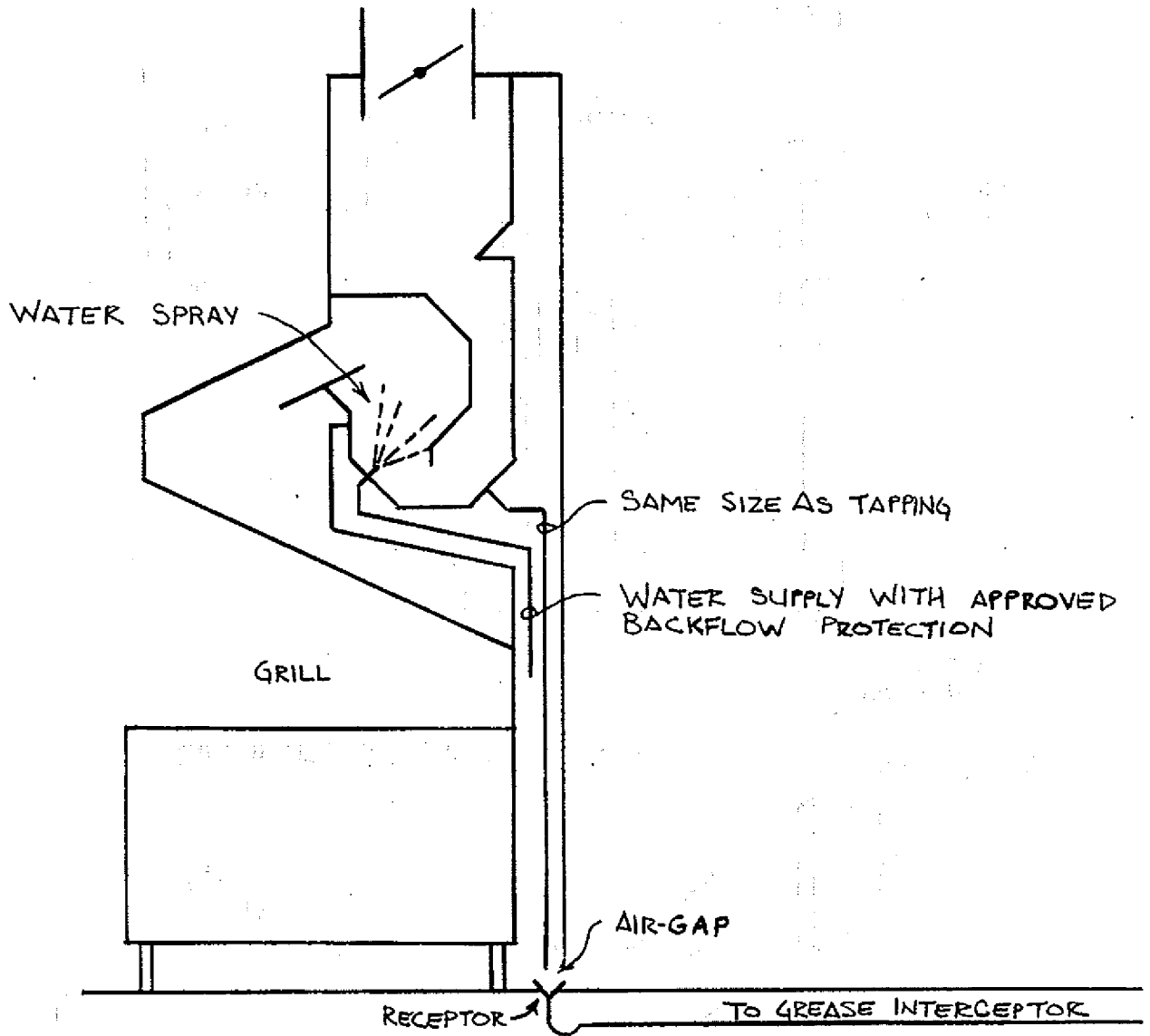

EXHAUST HOOD WASHER

A-82.34 (4) (a) PUBLIC BUILDINGS.

GARAGE CATCH BASIN

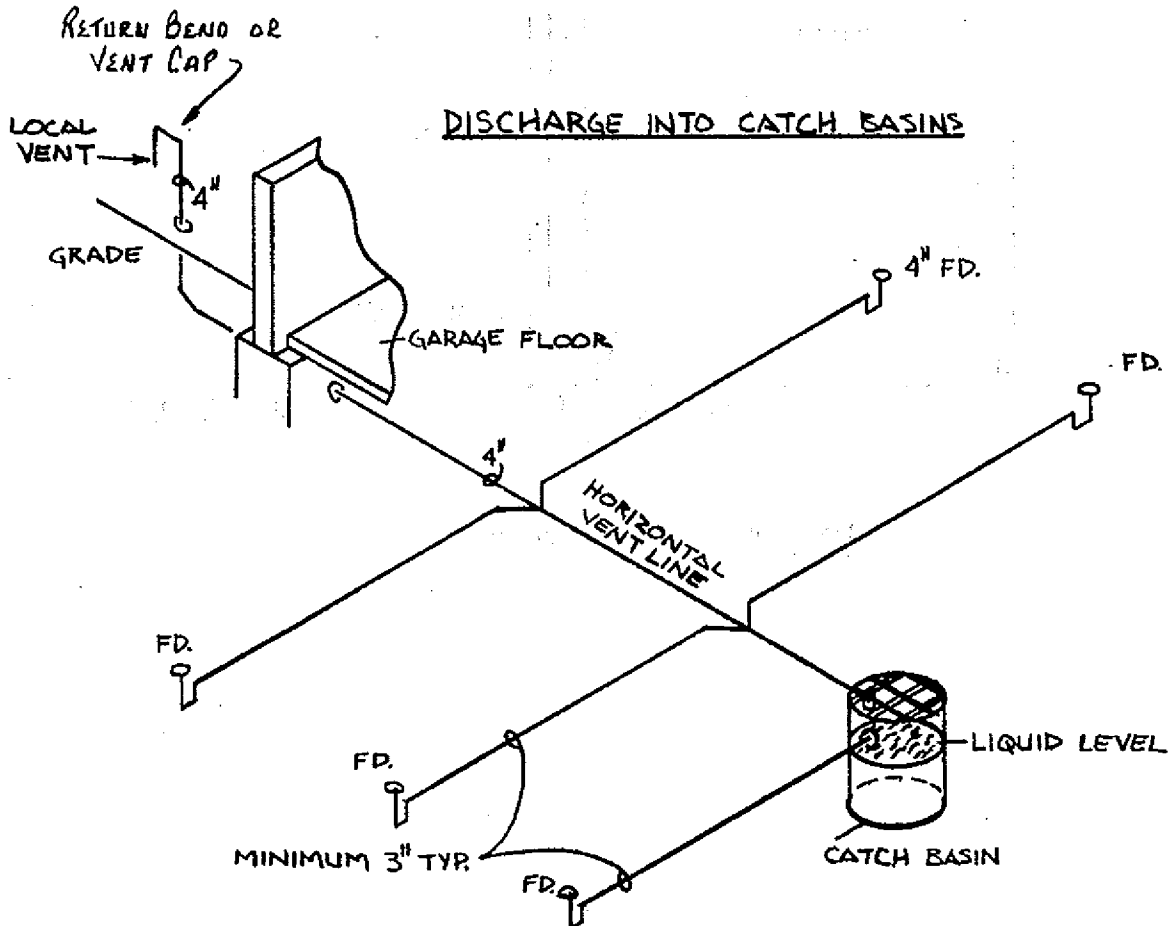
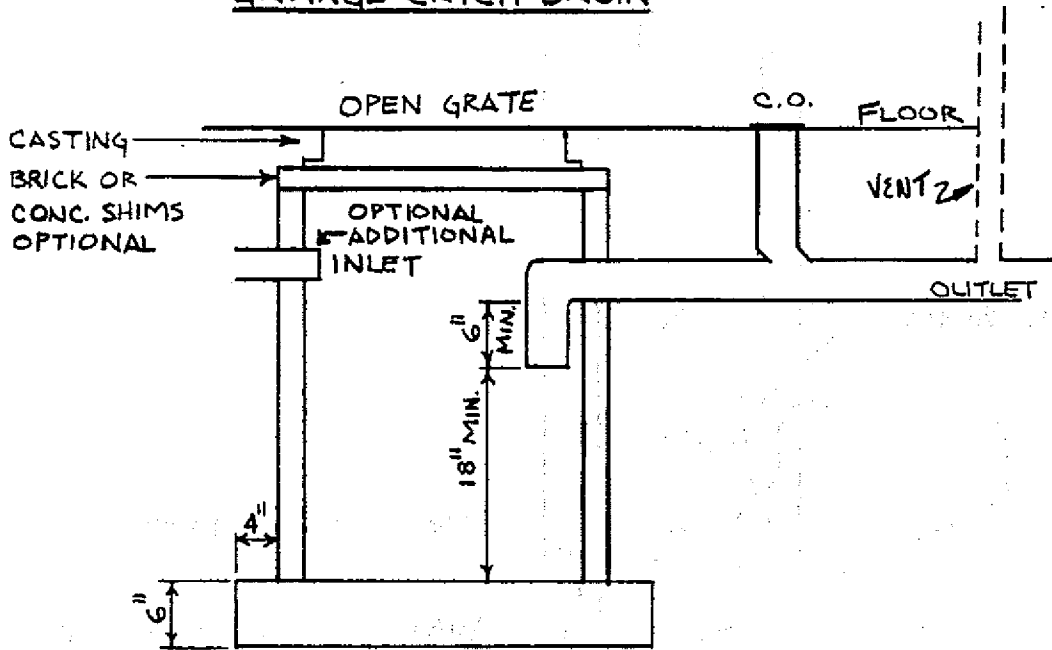

A-82.34 (4) (a) PUBLIC BUILDINGS.

Diameter of Catch Basin	Volume in cubic feet per foot of depth	Diameter of Catch Basin	Volume in cubic feet per foot of depth
36	7.1	45	11.1
37	7.5	46	11.6
38	7.9	47	12.1
39	8.3	48	12.6
40	8.7	54	15.9
41	9.2	60	19.7
42	9.7	66	23.8
43	10.1	72	28.3
44	10.6	84	38.6

A-82.34 (4) (a) PUBLIC BUILDINGS.

TRENCH DRAINS

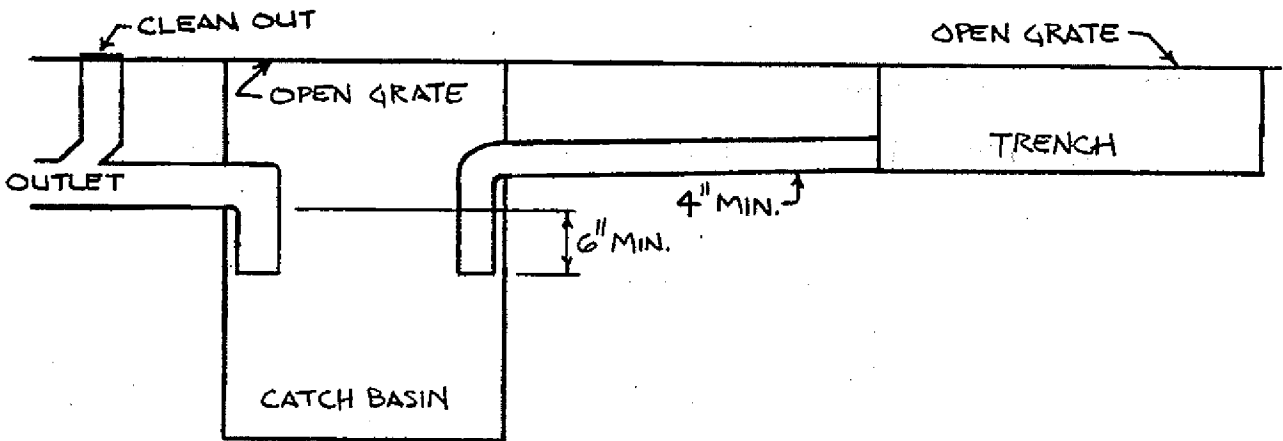

A-82.34 (4) (b) GARAGES FOR ONE- AND 2-FAMILY DWELLINGS.

TYPICAL FLOOR DRAIN WITH SOLID BOTTOM SEDIMENT BASKET

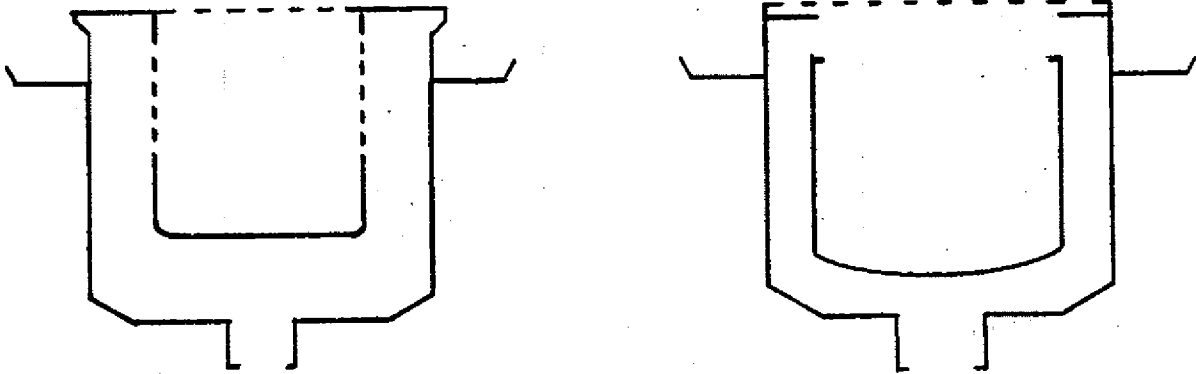

A-82.34 (5) (b) EXTERIOR GREASE INTERCEPTORS.

GREASE INTERCEPTOR MANHOLE LOCATION

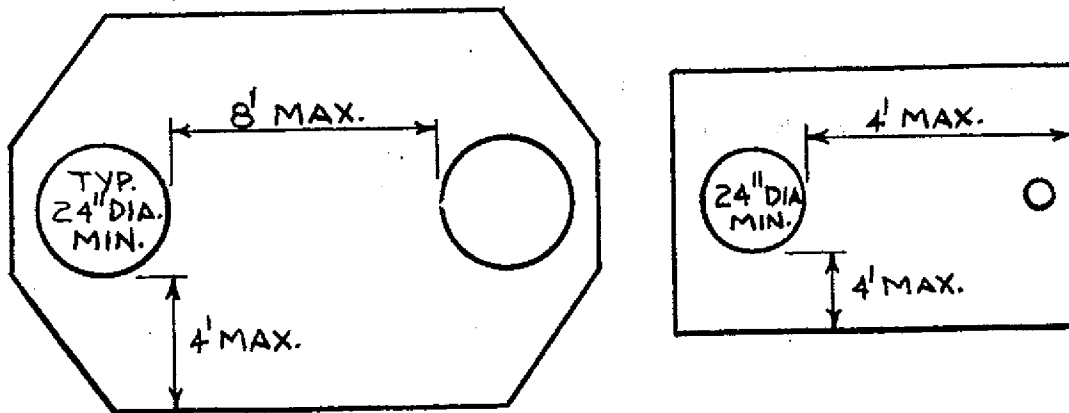

A-82.34 (5) (b) EXTERIOR GREASE INTERCEPTORS.

EXTERIOR GREASE INTERCEPTOR

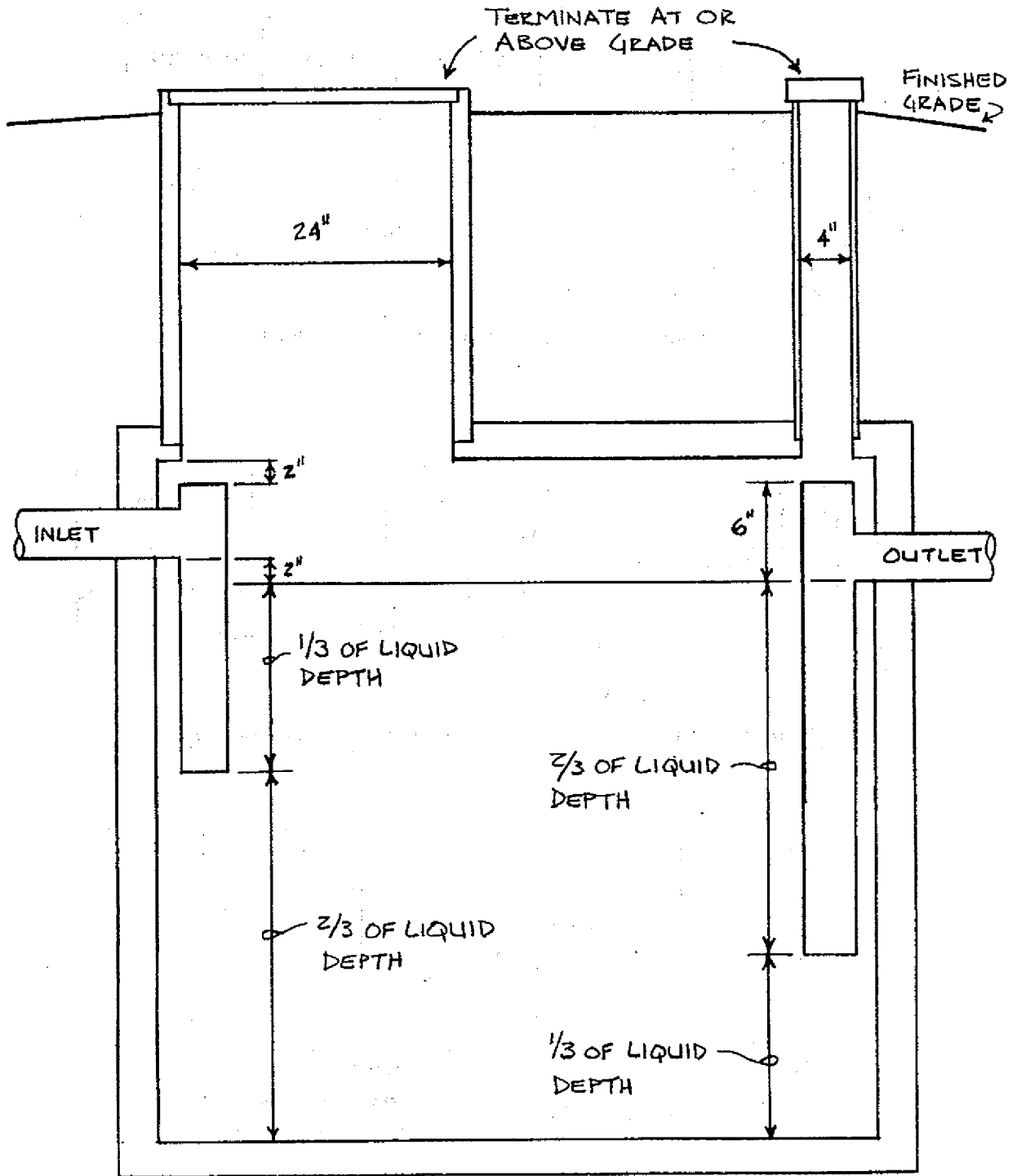

A-82.34 (5) (c) INTERIOR GREASE INTERCEPTORS.

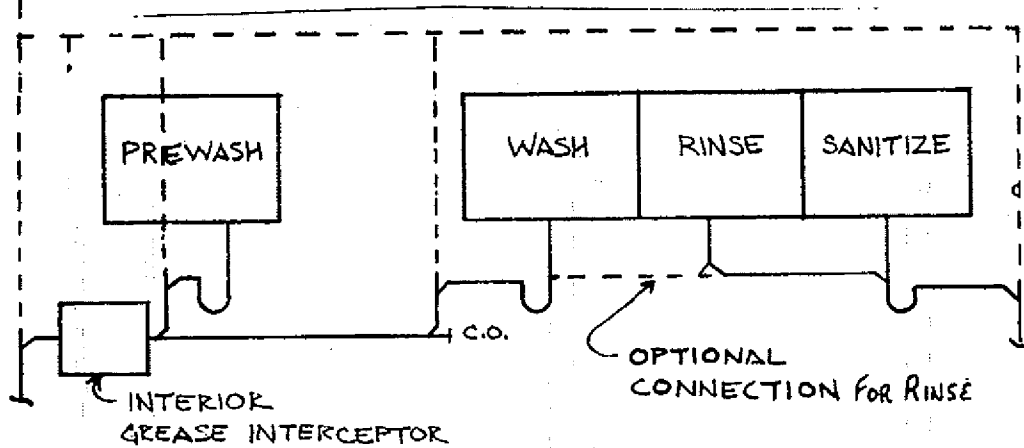

PREWASH AND 3 COMPARTMENT SCULLERY SINK

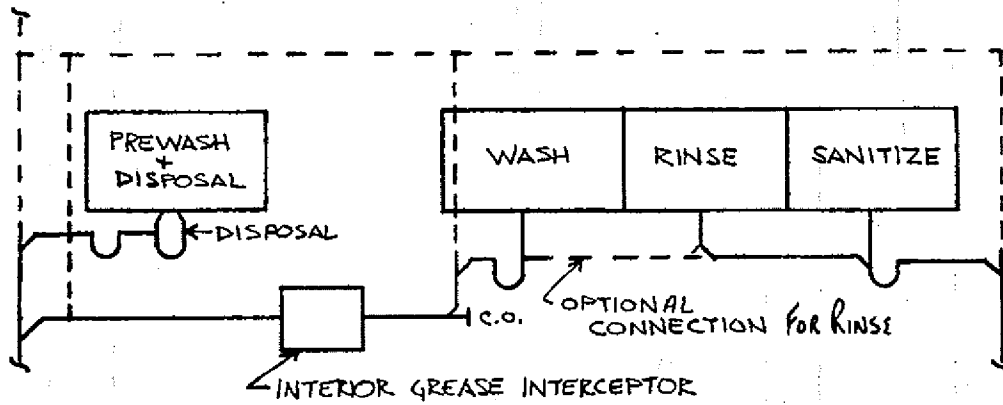

PREWASH + DISPOSAL + 3 COMPARTMENT SCULLERY SINK

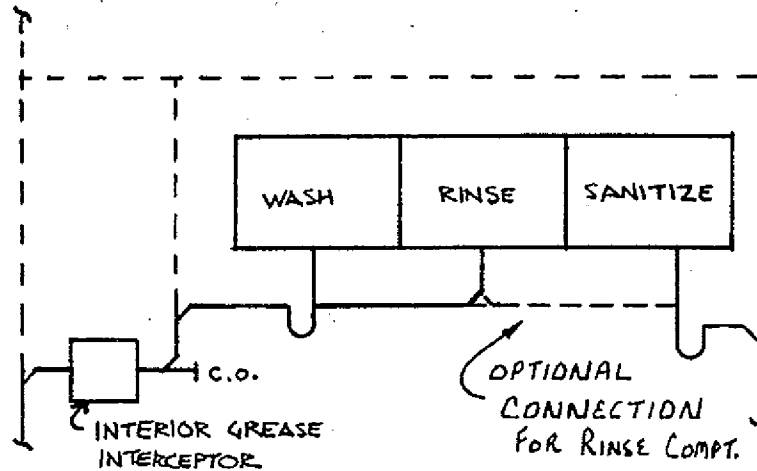

3 COMPARTMENT SCULLERY SINK

Note: Rinse and sanitize compartments and garbage disposals may discharge through interior grease interceptors.

A-82.34 (6) AUTOMATIC CAR WASHES.

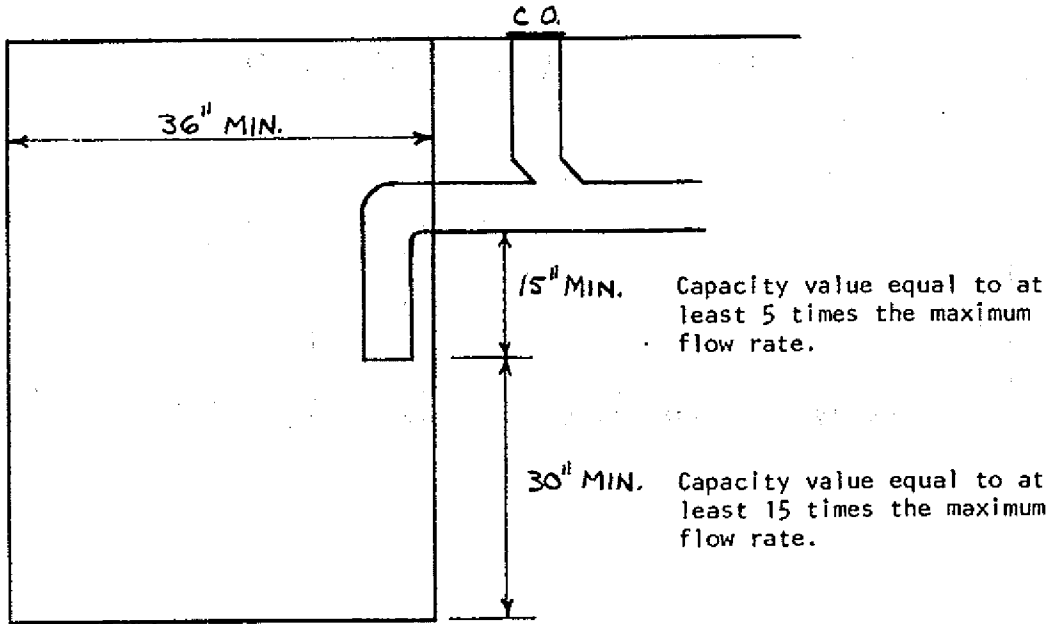

CAR WASH INTERCEPTOR WITH INVERT INSIDE OF BASIN

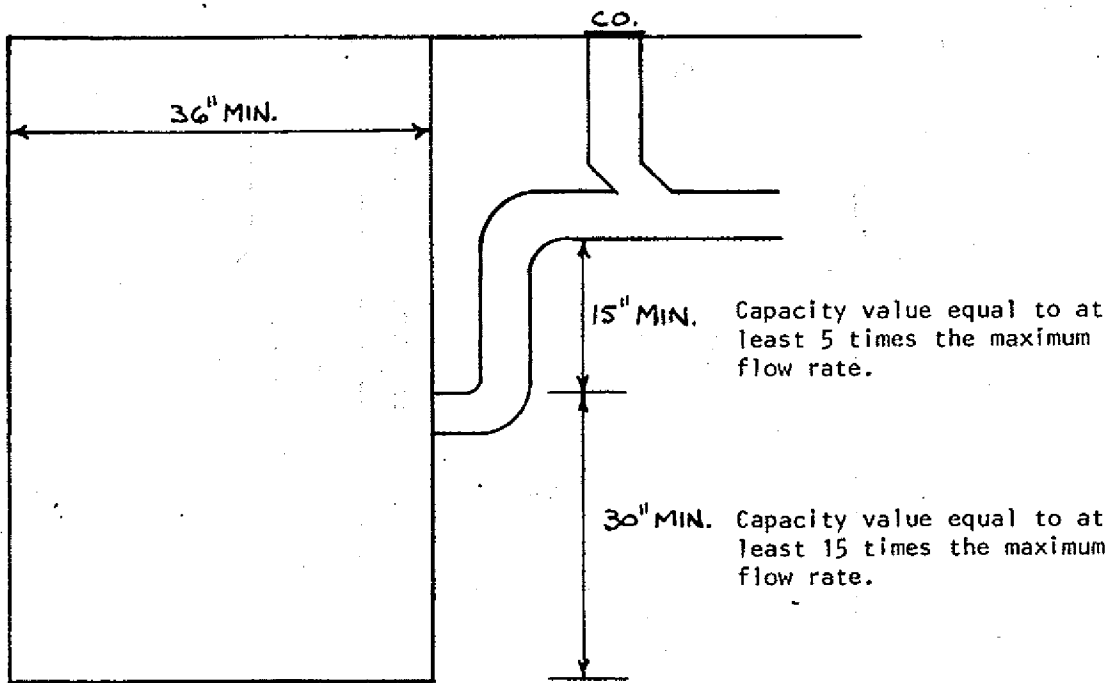

CAR WASH INTERCEPTOR WITH INVERT OUTSIDE OF BASIN

A-82.34 (7) COMMERCIAL LAUNDRIES.

TRENCH TYPE LAUNDRY INTERCEPTOR

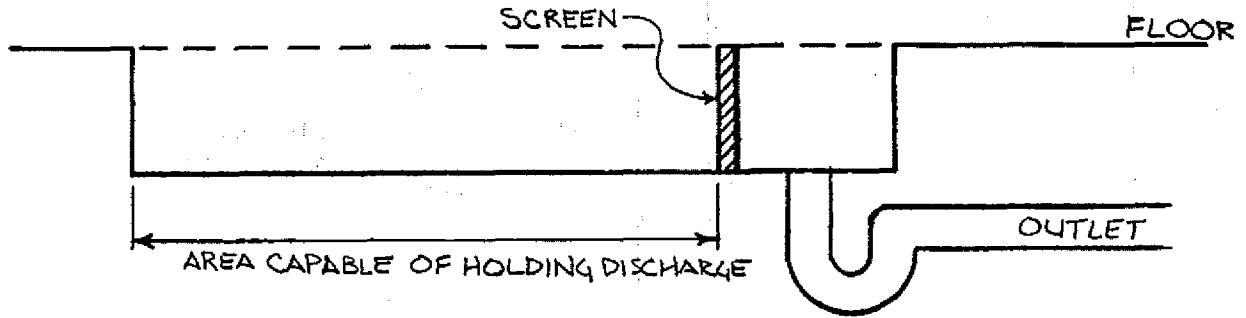

IN-LINE LAUNDRY INTERCEPTOR

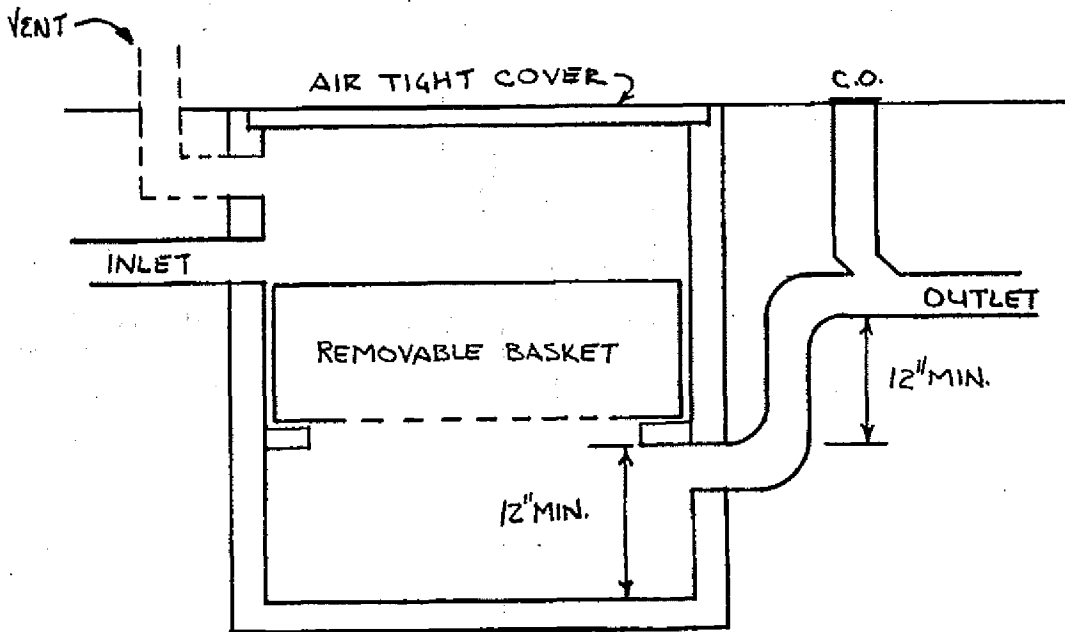

A-82.34 (8) OIL AND FLAMMABLE LIQUIDS.

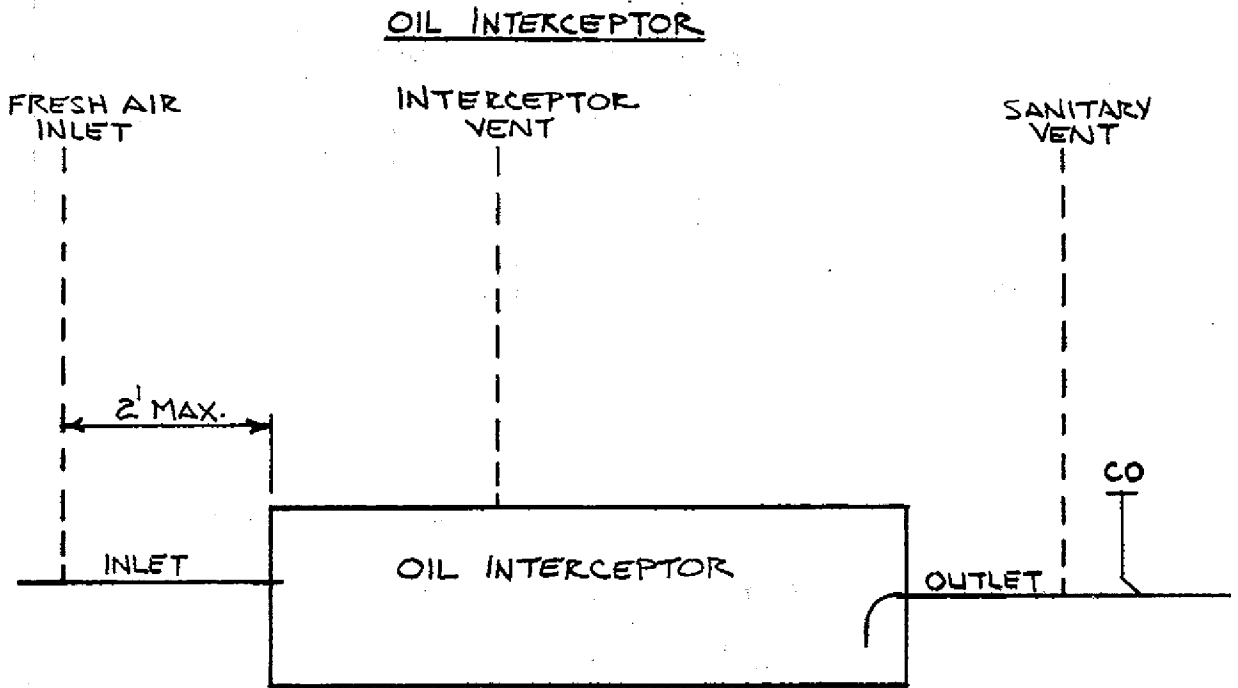

A-82.34 (13) PLASTER AND HEAVY SOLIDS TRAP TYPE INTERCEPTORS.

PLASTER AND HEAVY SOLIDS TRAP

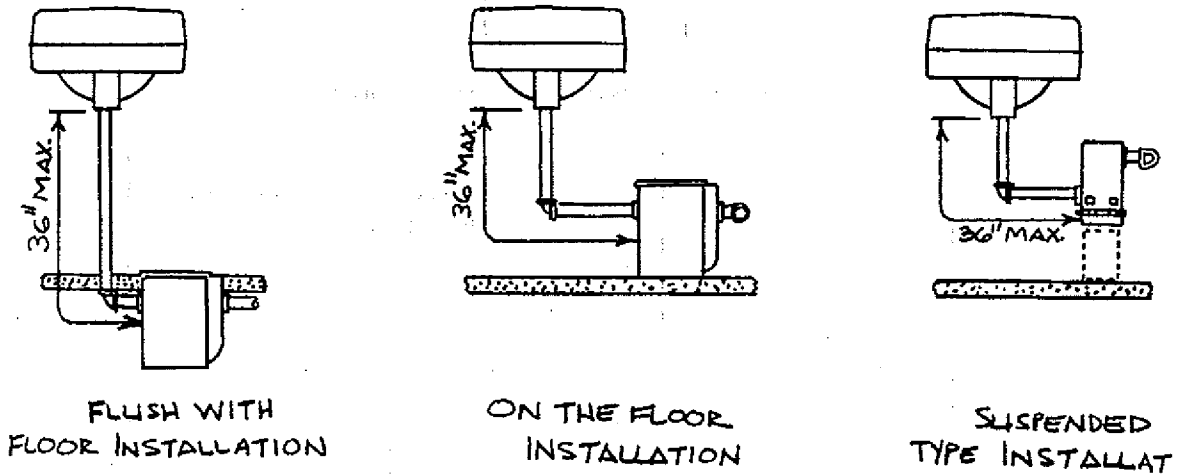

A-82.34 (14) CHEMICAL DILUTION AND NEUTRALIZING BASINS.

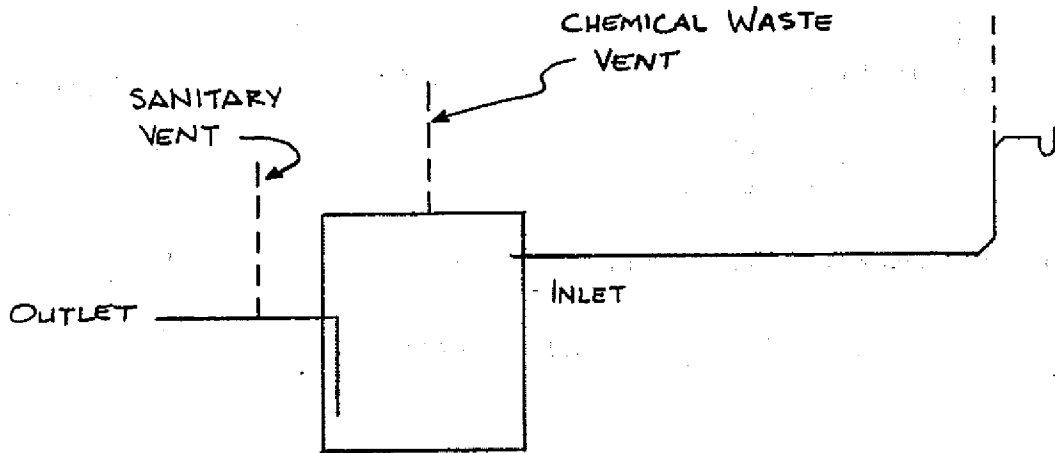
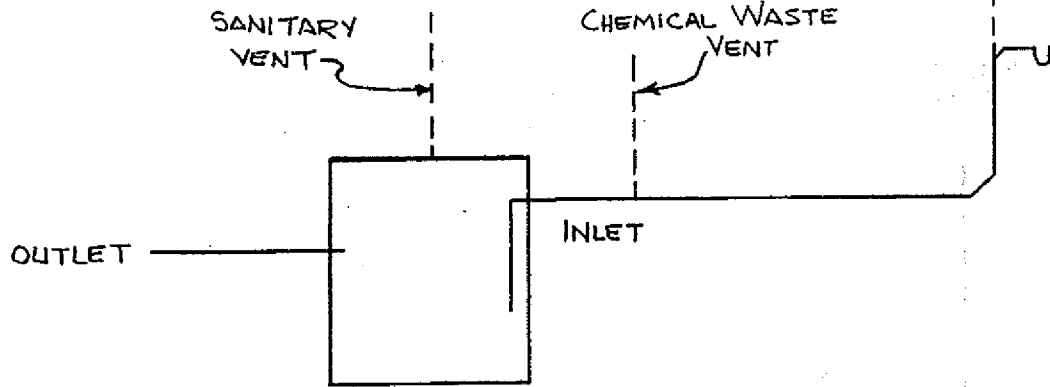

A-82.35 (3) CLEANOUTS SERVING HORIZONTAL DRAINS WITHIN OR UNDER A BUILDING.

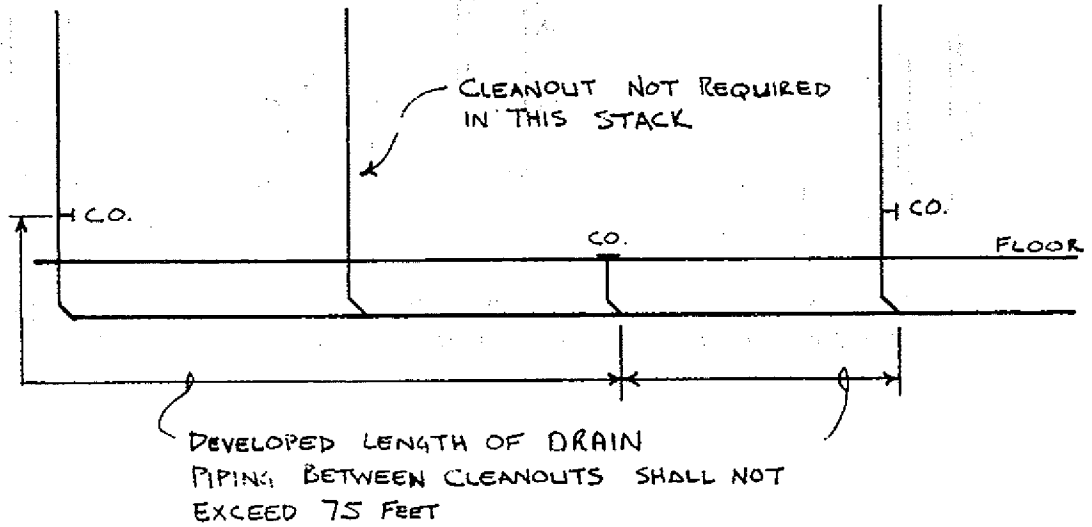

A-82.35 (3) CLEANOUTS SERVING HORIZONTAL DRAINS.

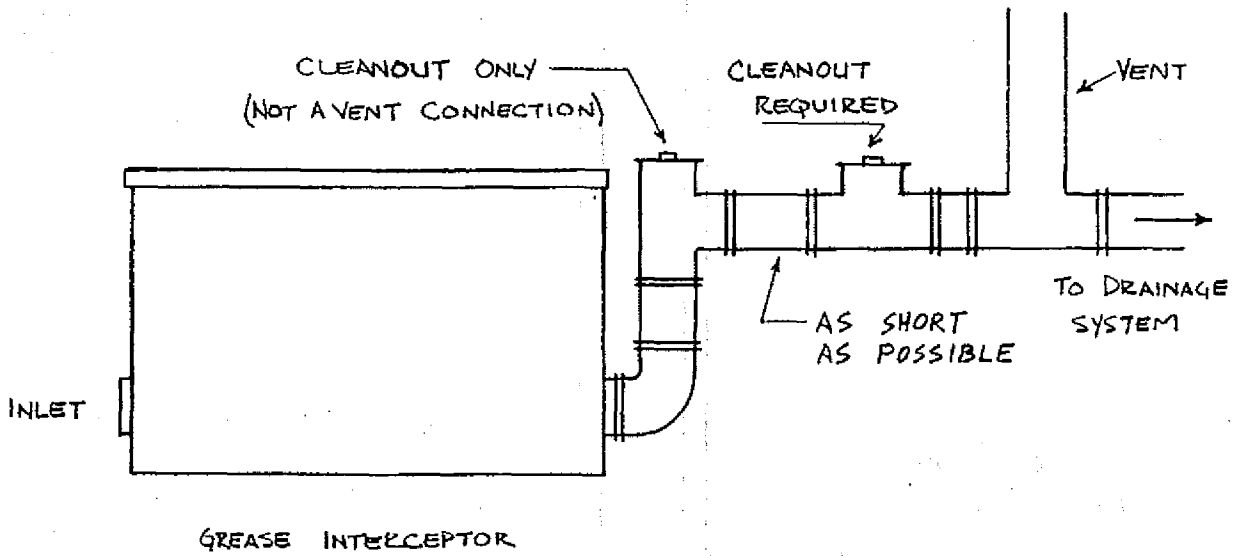
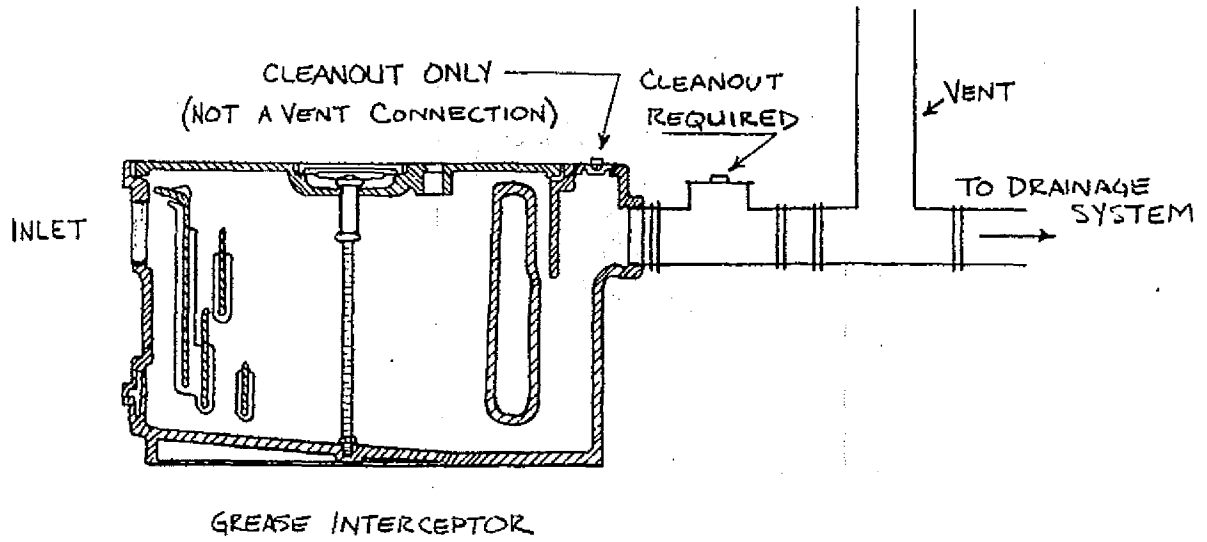

A-82.35 (5) (a) CLEANOUT EXTENSION TO GRADE.

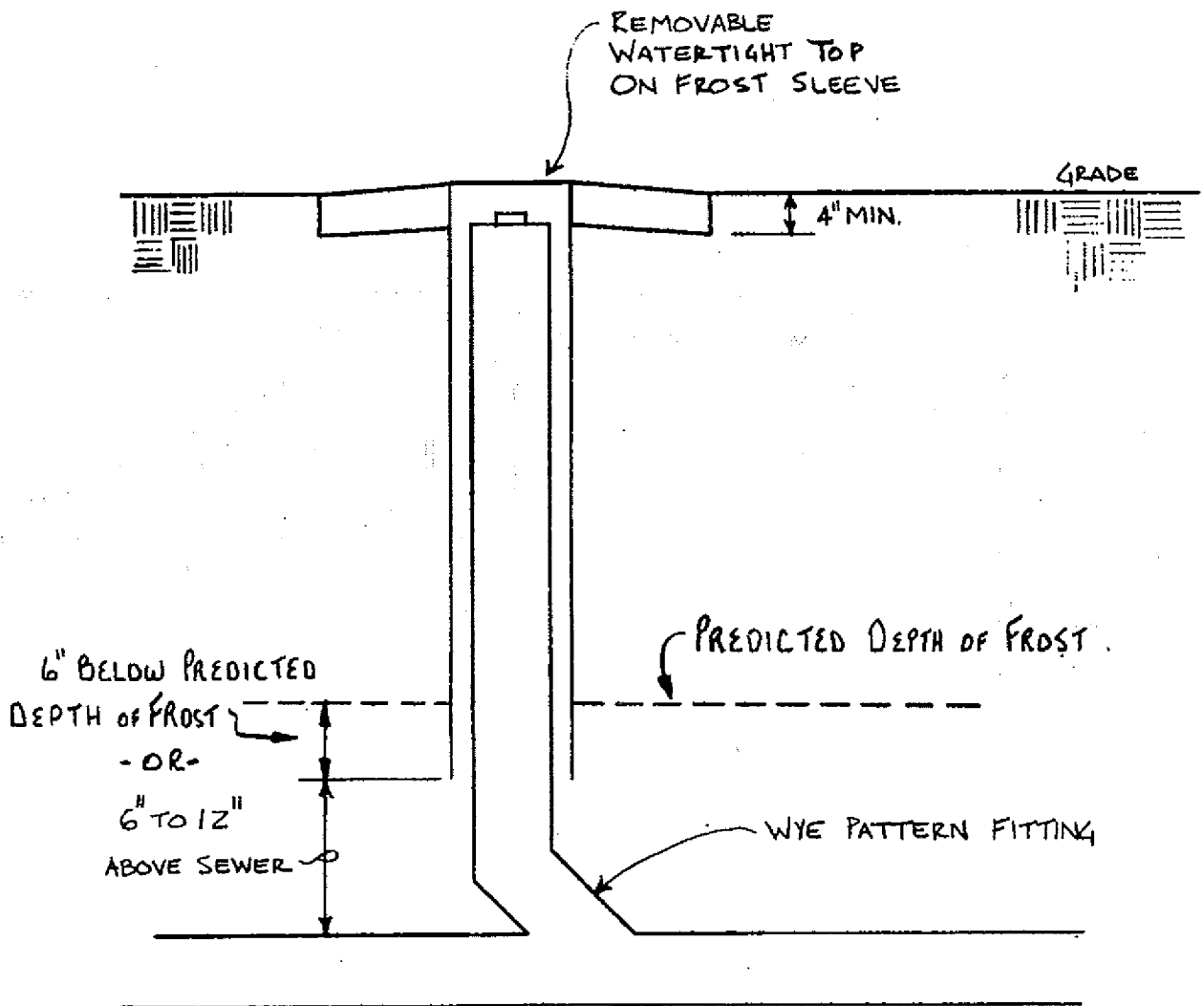
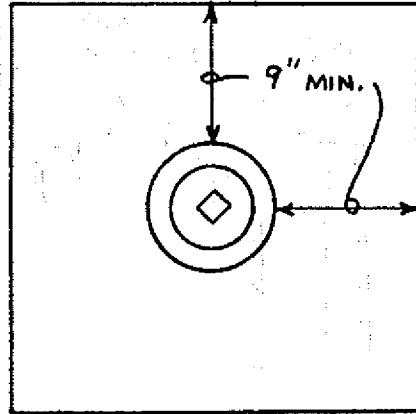

A-82.35 (8) MANHOLES.

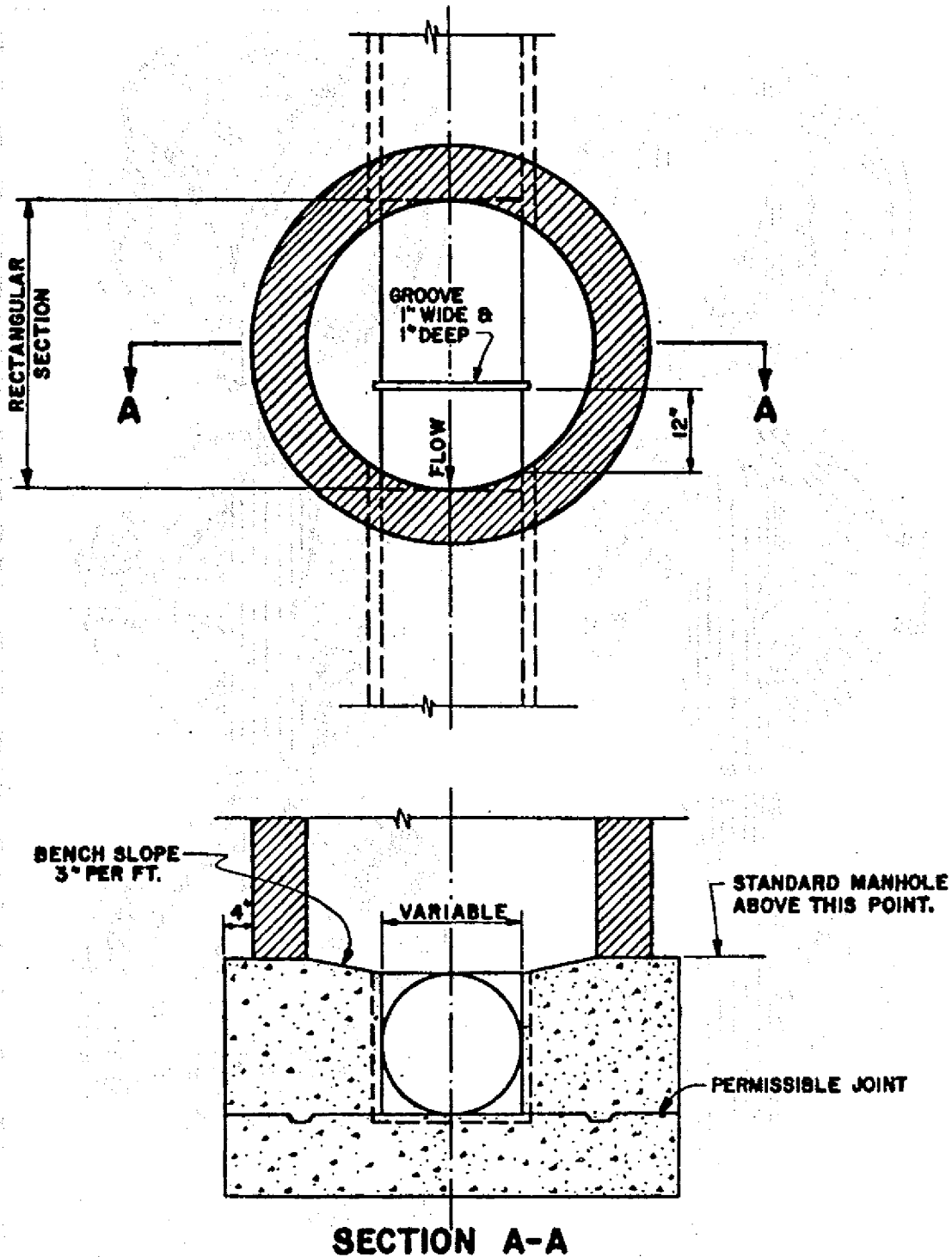

DETAIL OF SAMPLING MANHOLE

A-82.35 (8) MANHOLES.

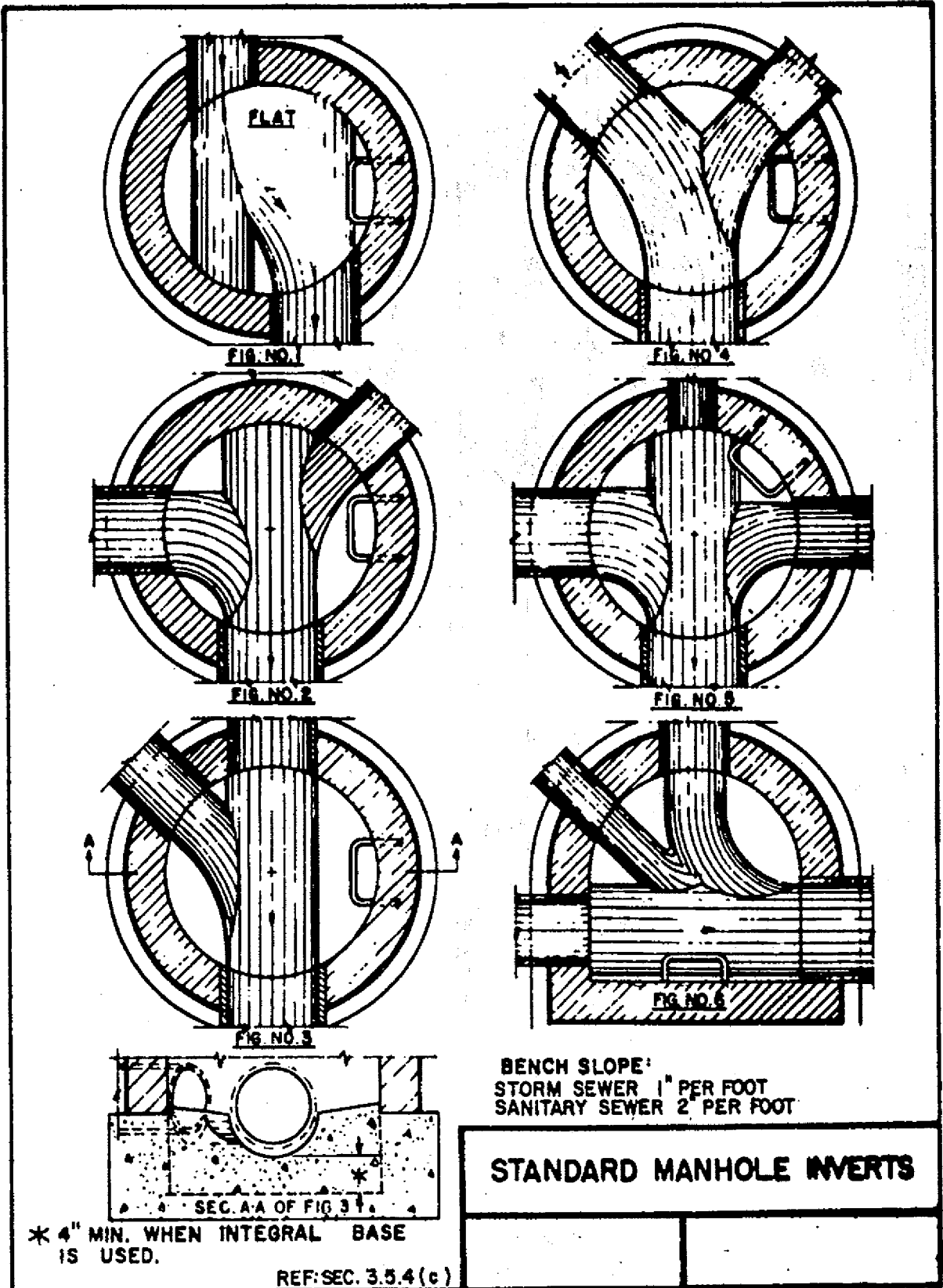

A-82.35 (8) MANHOLES.

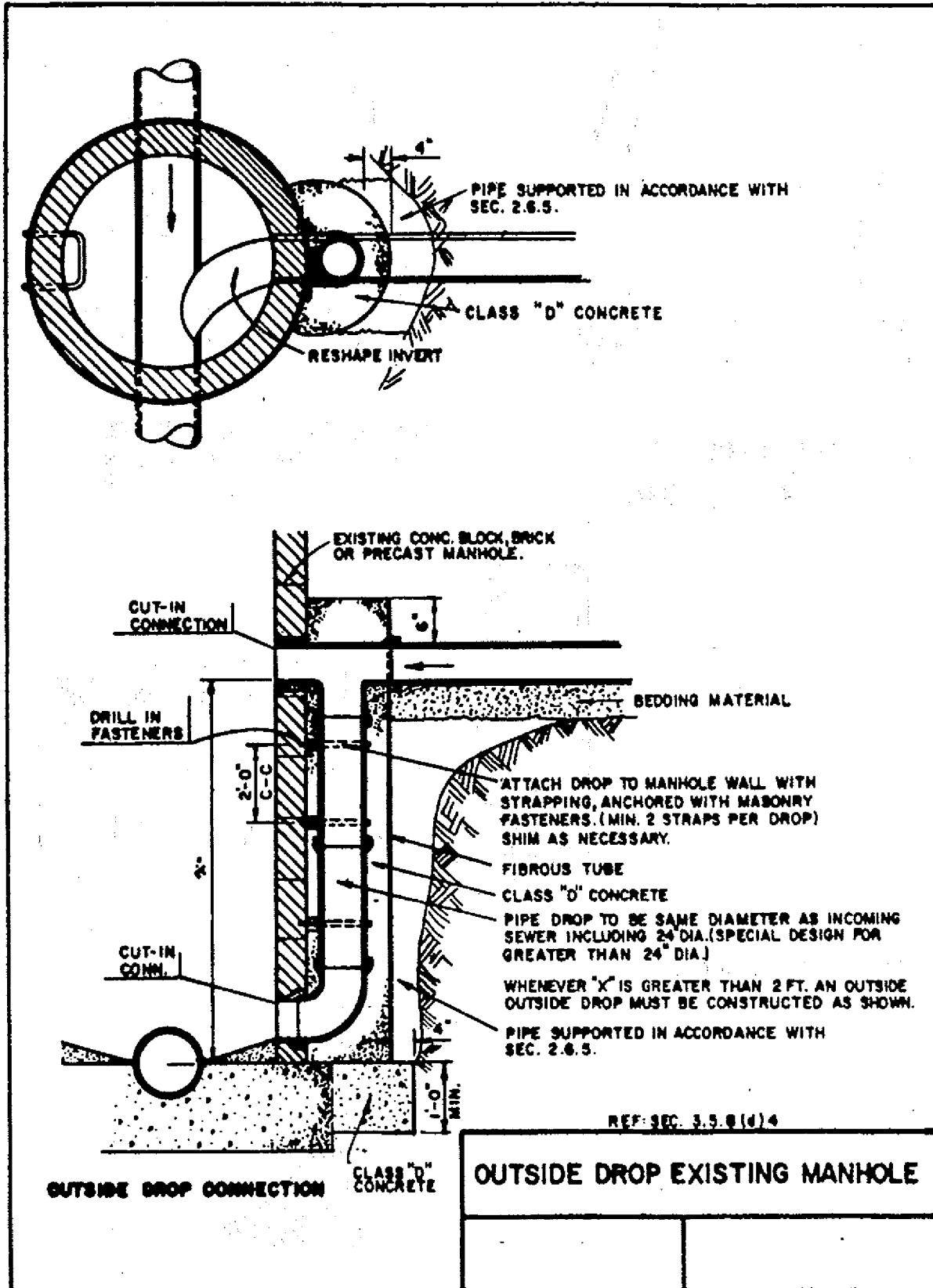

A-82.36 (17) AREA DRAIN INLETS.

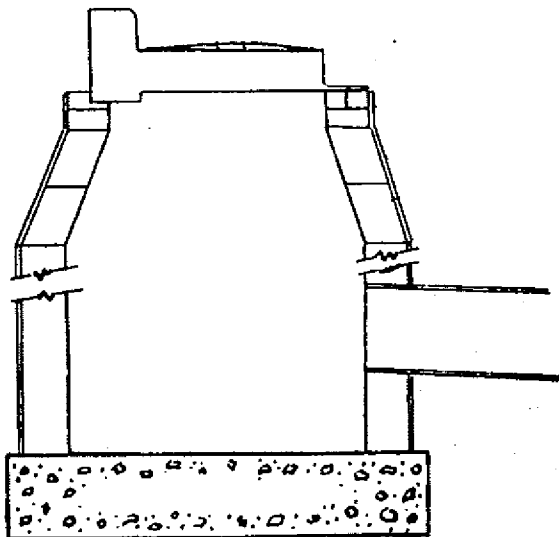

STANDARD STORM WATER
CATCH BASIN (MASONRY)

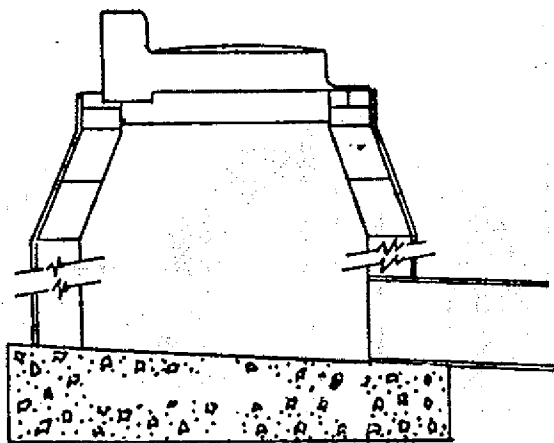

STANDARD STORM WATER
INLET (MASONRY)

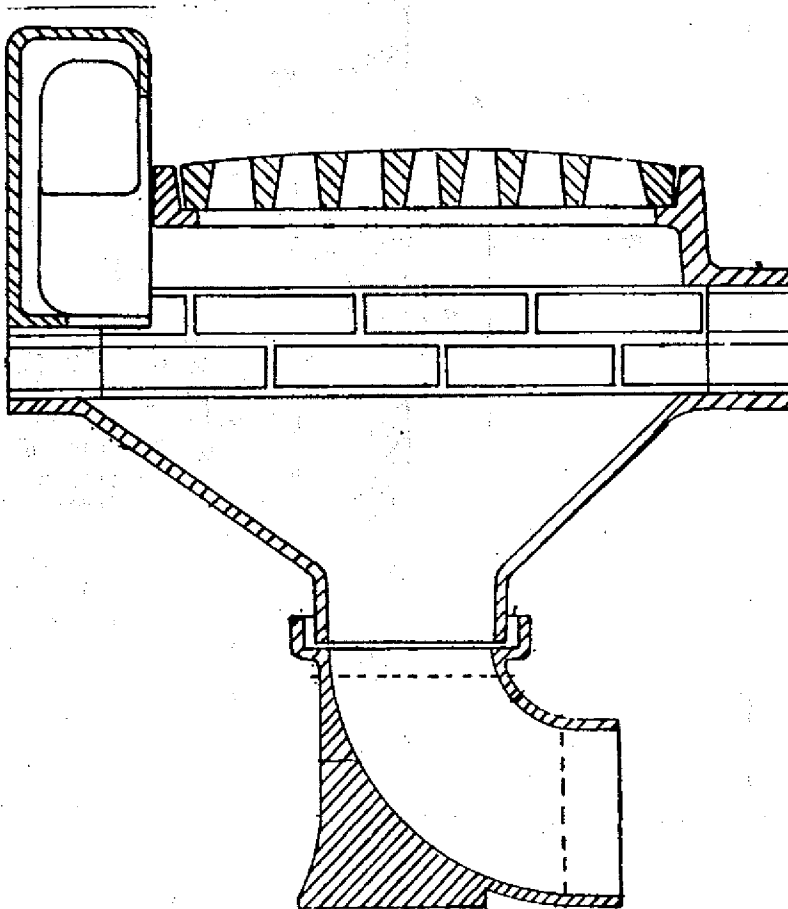

CAST IRON STORM
WATER INLET

A-82.40 (4) CONTROL VALVES.

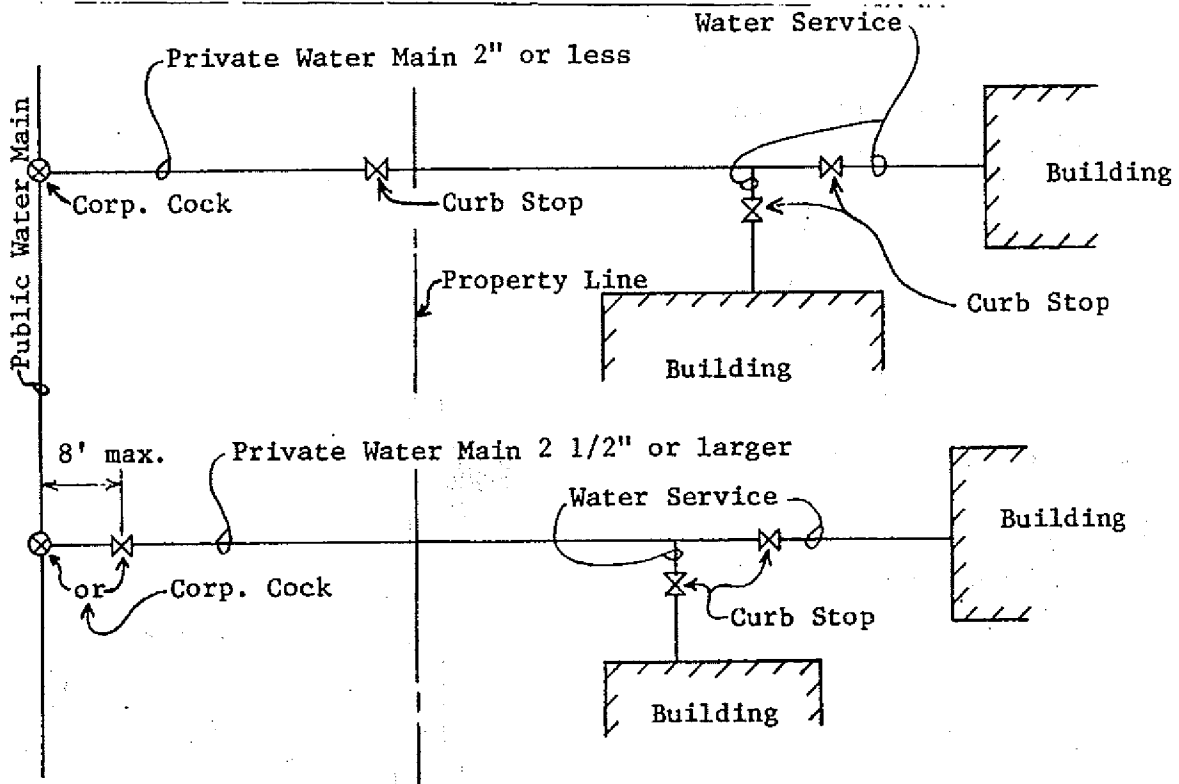

A-82.40 (4) (b) WATER SERVICES.

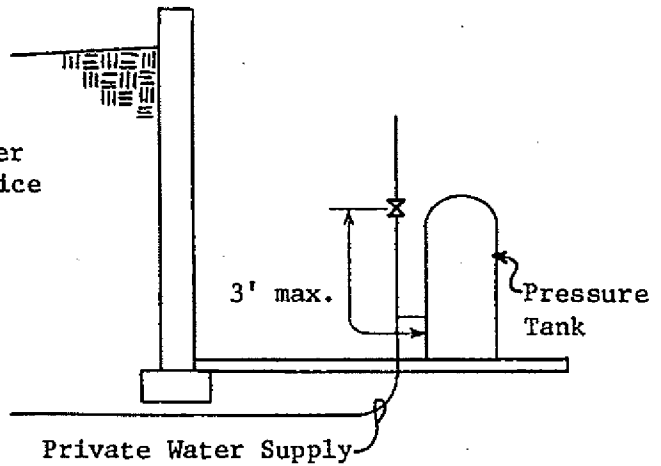
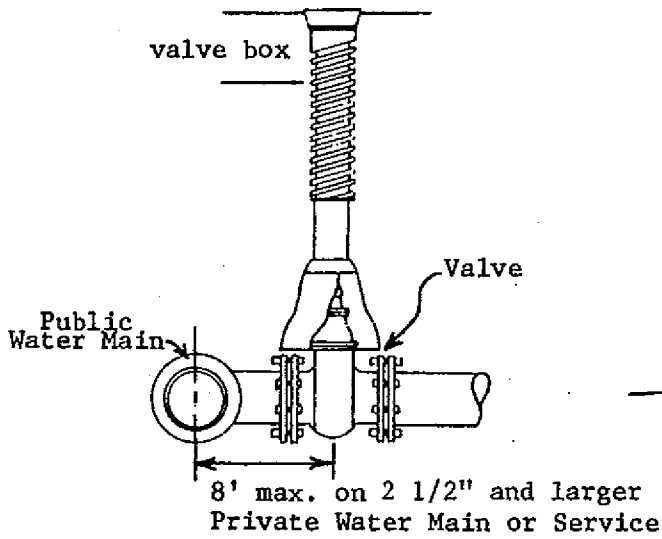
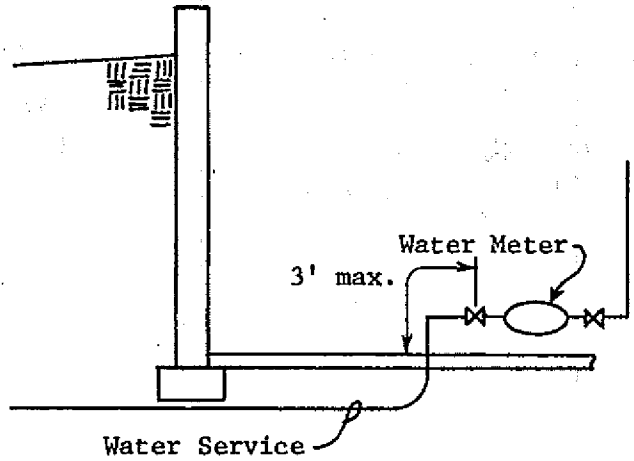
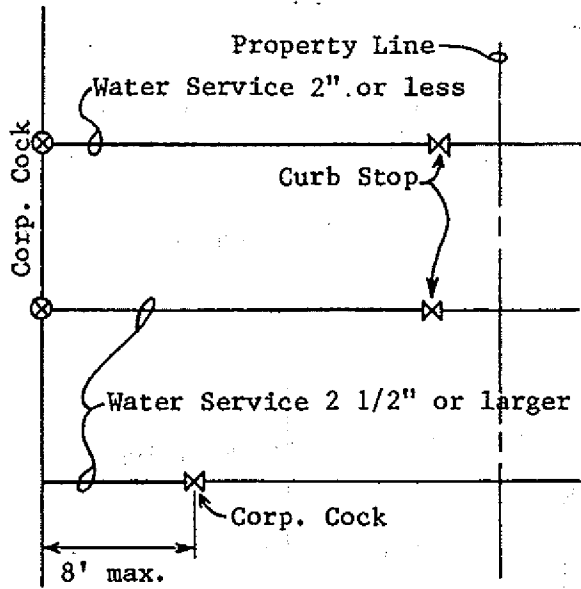

A-82.40 (5) STORAGE TANK AND PIPING INSULATION. The following is a reprint of section ILHR 63.63.

ILHR 63.33 Insulation. (1) STORAGE TANKS. Heat loss from unfired hot water storage tanks shall be limited to 15 Btu of 25 Btu per hour square foot of external pipe insulation surface area. The design ambient temperature shall be no higher than 65° F.

(2) PIPING. (a) Except as provided in par. (b), piping heat loss for recirculation systems shall be limited to a maximum of 25 Btu per hour square foot of external pipe insulation surface for aboveground piping and a maximum of 35 Btu per hour per square foot of external pipe insulation for under ground piping. Maximum heat loss shall be determined at a ΔT equal to the maximum water temperature minus a design ambient temperature no higher than 65° F.

(b) Conformance to the minimum pipe insulation requirements specified in Table 63.22 shall be deemed as complying with the requirements of this subsection.

A-82.40 (7) (a) METHODOLOGY.

Where equipment such as an instantaneous or tankless water heater, water treatment device, water meter, and backflow preventer is provided in the design, the friction loss in such equipment, corresponding to the GPM demand, should be determined from the manufacturer or other reliable source.

Where a direct fired pressurized tank type water heater is provided in the design, the friction loss for such equipment can be assumed as part of the pressure losses due to flow through piping, fittings, valves and other plumbing appurtenances when the developed length of piping is multiplied by 1.5.

The pressure losses due to flow friction through displacement type cold-water meters may be calculated from Graph A-82.40 (7)-1.

Graph A-82.40 (7) - 1
PRESSURE LOSS IN COLD-WATER METERS, DISPLACEMENT TYPE

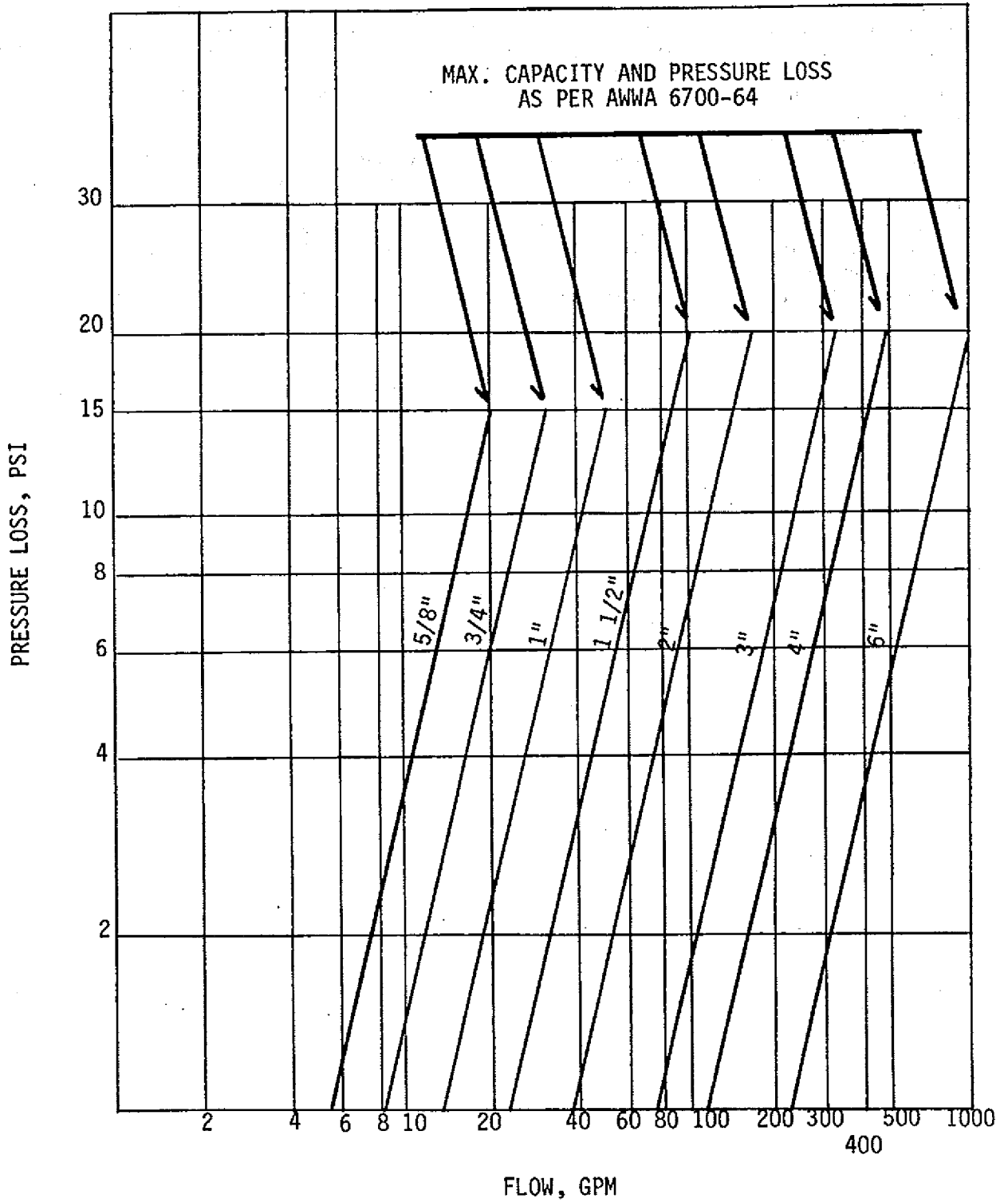

A-82.40 (7) (b) PRIVATE WATER MAINS AND WATER SERVICES.

Graphs A-82.40 (7)-2 to A-82.40 (7)-6 may be used to size private water mains and water services.

Graph A-82.40 (7)-2

Pressure losses due to flow friction

Material: Copper Tube-Type K, ASTM B88

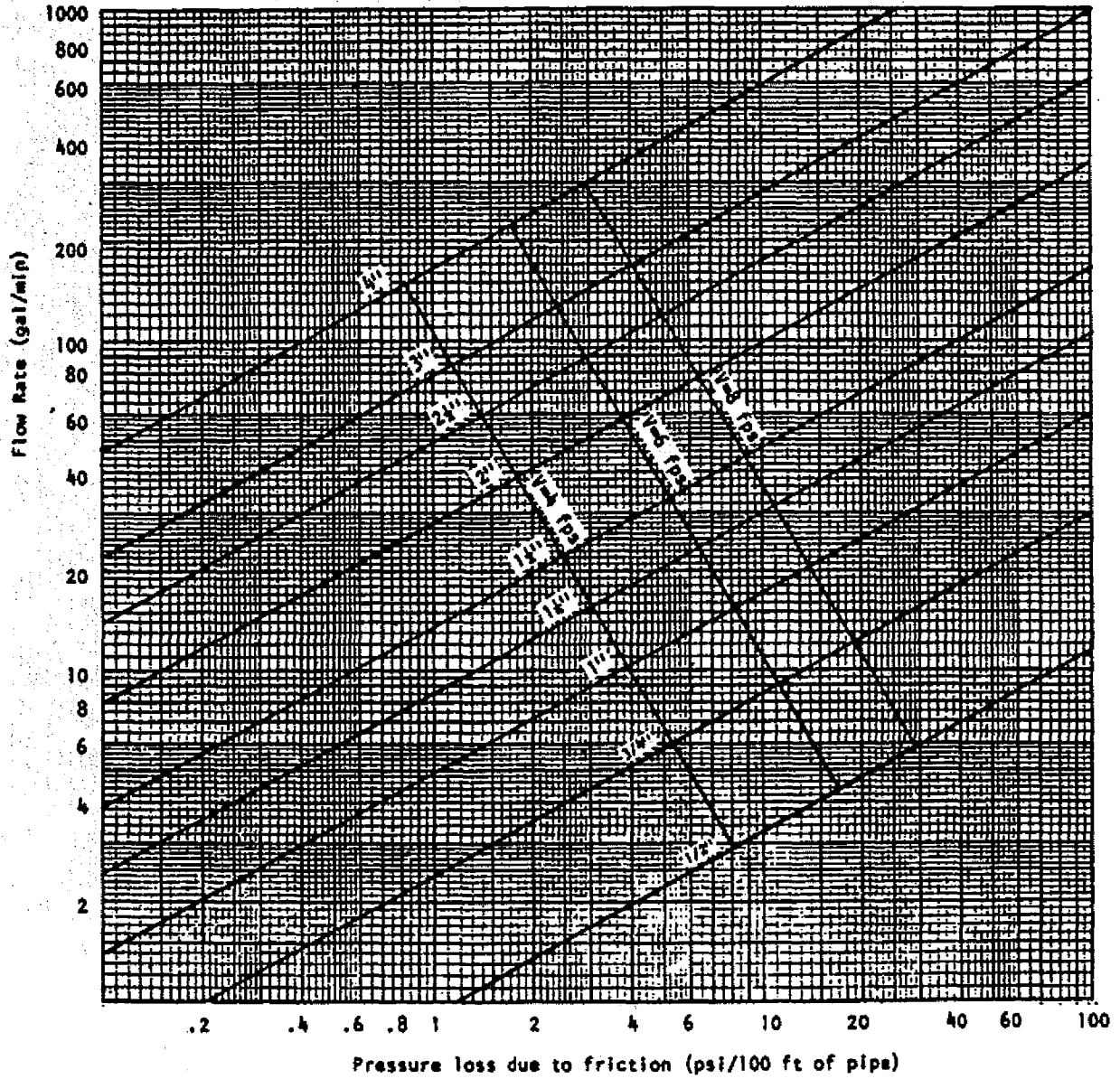

Graph A-82.40 (7)-3
Pressure losses due to flow friction
Material: Copper Tube-Type L, ASTM B88

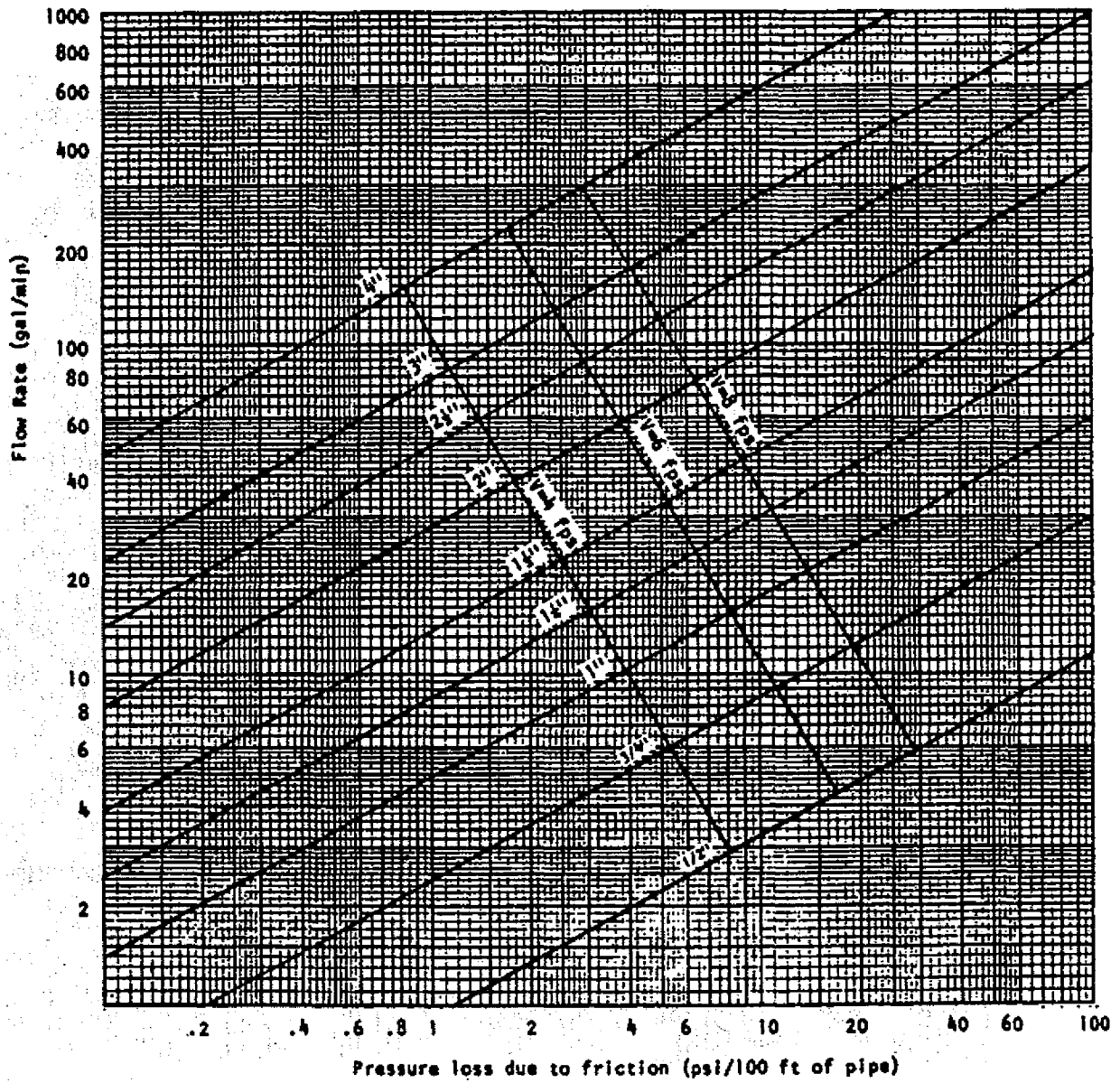

Graph A-82.40 (7)-4

Pressure losses due to flow friction

Material: Galvanized Steel Pipe—Schedule 40, ASTM A53, ASTM A120;
ABS Pipe—Schedule 40, ASTM D1527; or
CPVC Pipe—Schedule 40, ASTM F441; or
PE Pipe—Schedule 40, ASTM D2104; ASTM D2447; or
PVC Pipe—Schedule 40; ASTM D1785; ASTM D2672

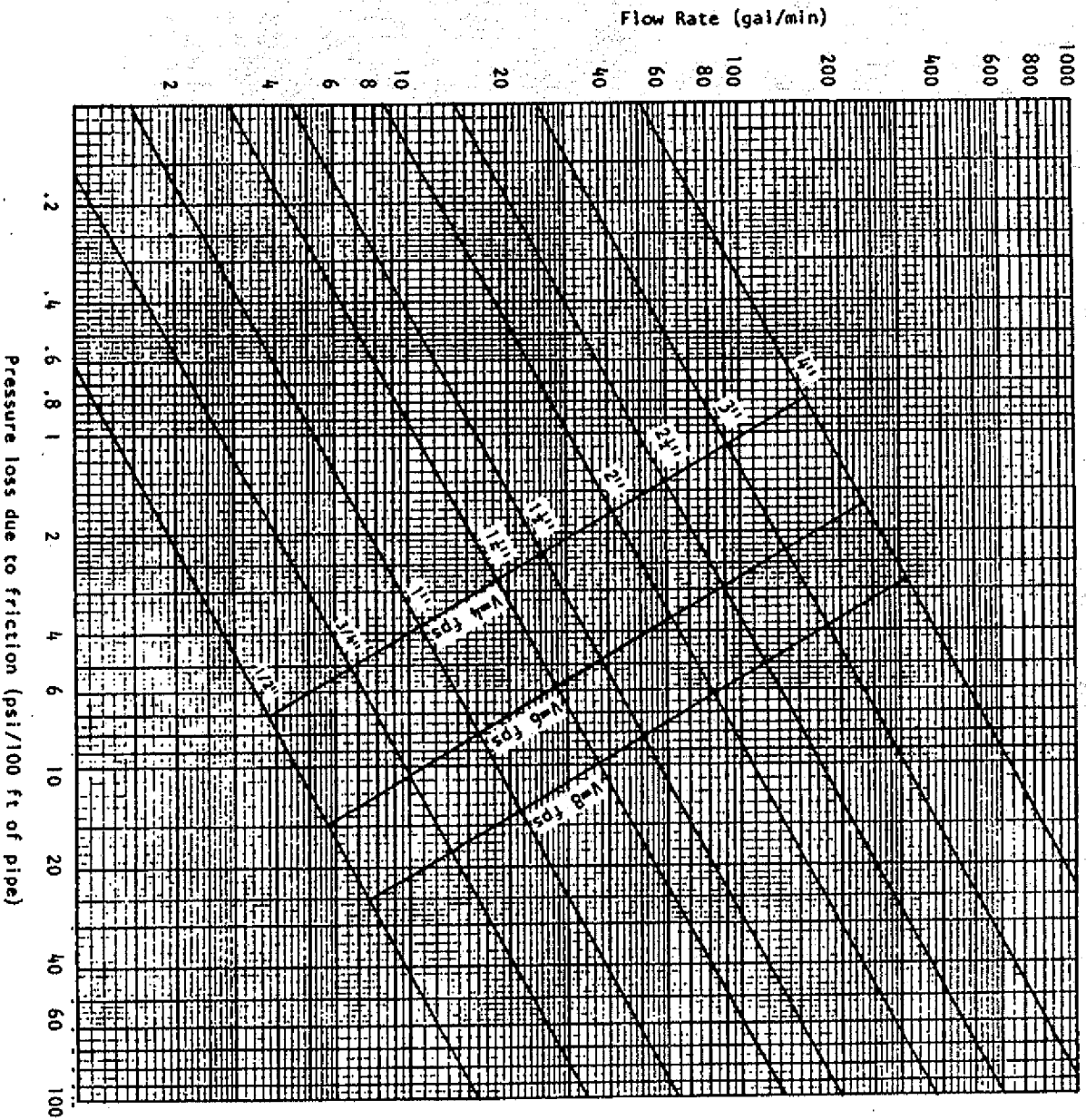

Graph A-82.40 (7)-5

Pressure losses due to flow friction
Material: Polybutylene Tubing, ASTM D3309; or
CPVC Tubing, ASTM D2846

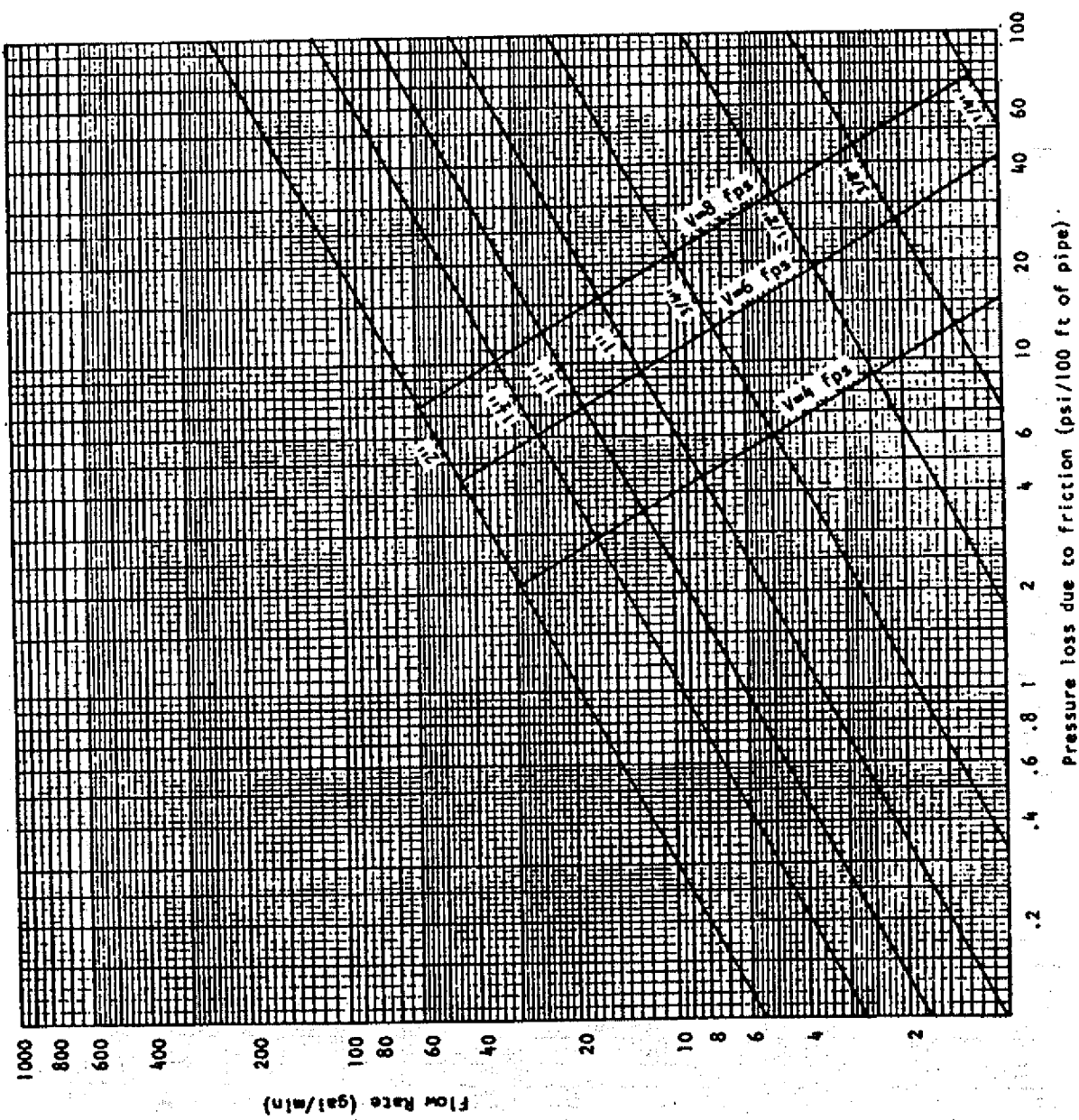

Graph A-82.40 (7)-6
Pressure losses due to flow friction
Material: Crosslinked Polyethylene (PEX) Tubing, ASTM F876

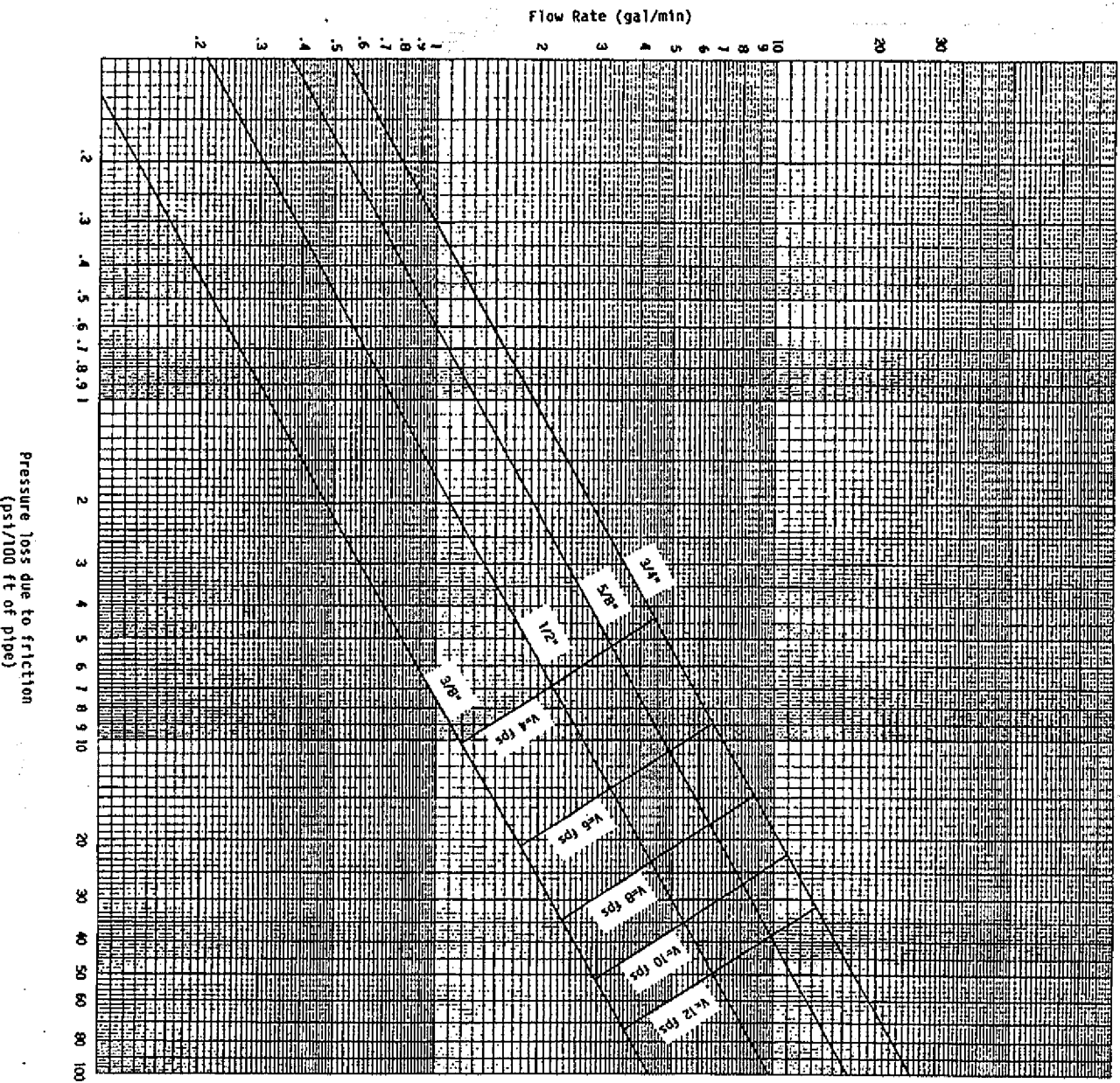

A-82.41 (5) (a) AIR GAP.

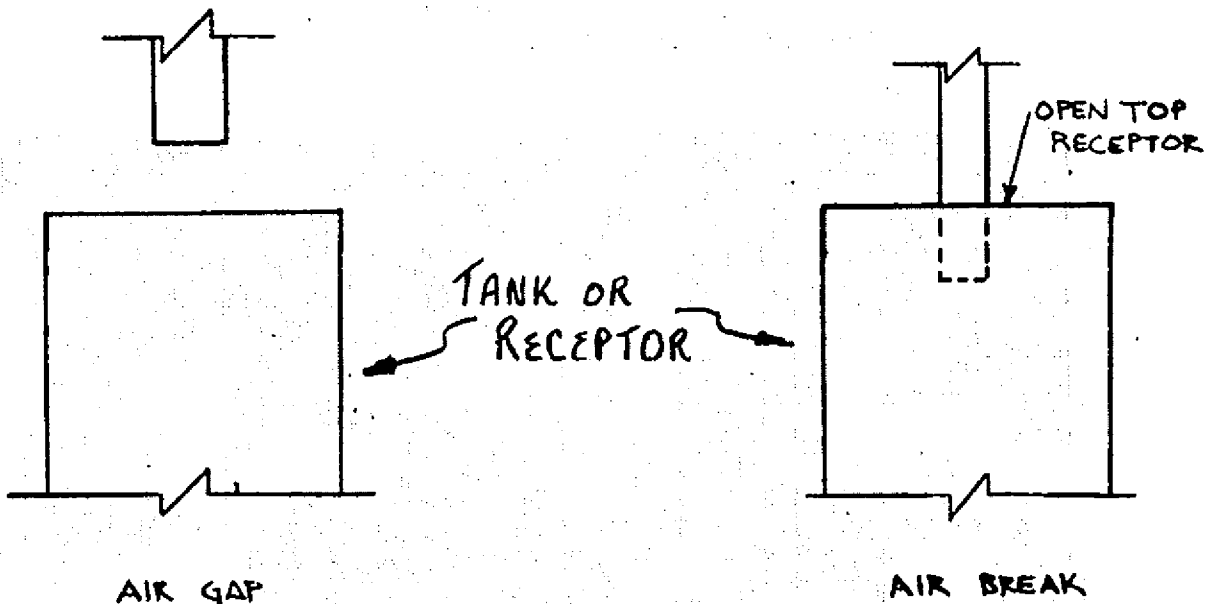

ANSI STANDARD A112.1.2 DESCRIBES OTHER ACCEPTABLE TYPES OF AIR GAPS.

A-82.51 (3) MOBILE HOME SITES AND PARKS.

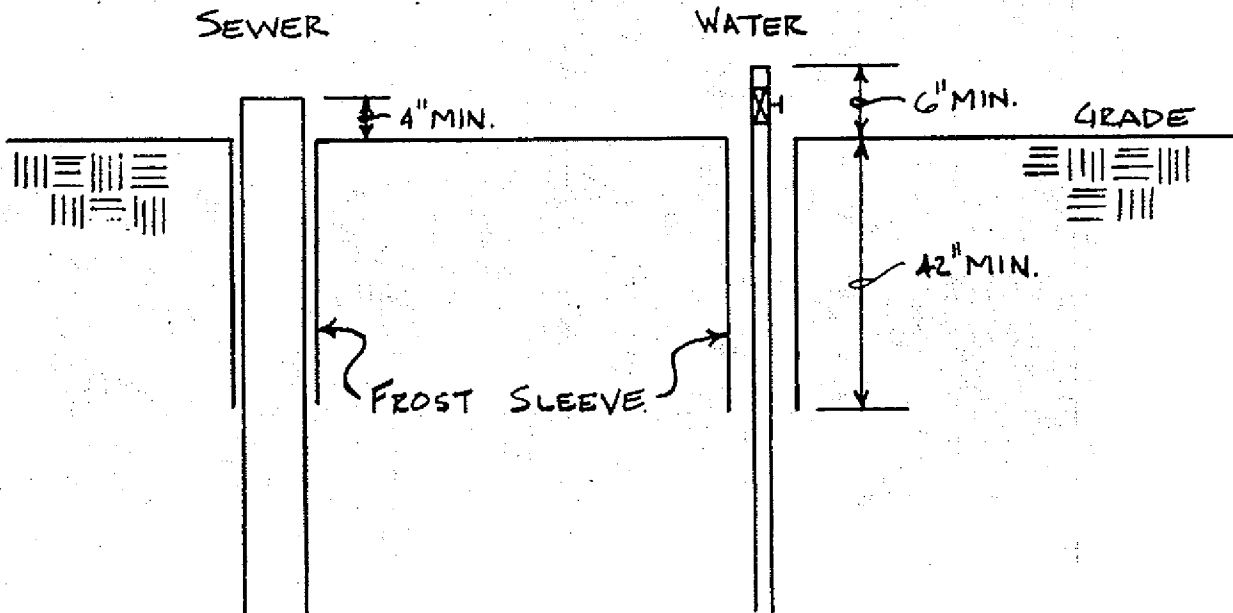

MOBILE HOME BUILDING SEWER AND WATER SERVICE TERMINATIONS