

Chapter H 62

**DESIGN, CONSTRUCTION, INSTALLATION,
SUPERVISION, AND INSPECTION
OF PLUMBING**

H 62.01	Basic plumbing principles	H 62.15	Materials
H 62.02	Definitions	H 62.16	Joints and connections
H 62.03	Fixture unit design basis	H 62.17	Repairs and reconstruction
H 62.04	Building sewers	H 62.18	Water supply systems
H 62.05	Building drains	H 62.19	Back siphonage and cross connections
H 62.06	Stacks and branches	H 62.20	Sewage treatment and disposal systems
H 62.07	Vents	H 62.21	Inspection and tests
H 62.08	Traps	H 62.22	Sketches
H 62.09	Cleanouts	H 62.23	Approval on experimental basis
H 62.10	Floor drains	H 62.24	Industrial commission regulations
H 62.11	Catch basin, sumps, ejectors		
H 62.12	Fixtures		
H 62.13	Rain water connections		
H 62.14	Special requirements		

H 62.01 Basic plumbing principles. (1) All premises intended for human occupation or occupancy shall be provided with a supply of pure and wholesome water; such supply shall not be cross connected with an unsafe water supply nor with a waste pipe.

(2) Buildings in which water closets and other plumbing fixtures exist shall be provided with a supply of water adequate in volume and pressure for flushing purposes.

(3) The pipes conveying water to water closets shall be of sufficient size to supply the water at a rate required for adequate flushing without unduly reducing the pressure at other fixtures.

(4) Devices for heating water and storing it in "boilers", or hot water tanks, shall be so designed and installed as to prevent all dangers of explosion, and also prevent backflow of hot water through a meter connected with a public water supply.

(5) Every building intended for human habitation or occupancy on premises abutting on a street in which there is a public sewer shall have a connection with the sewer.

(6) In multiple dwellings provided with a house drainage system, there shall be at least one private water closet for each family.

(7) Plumbing fixtures shall be made of smooth nonabsorbent material, shall be free from concealed fouling surfaces, and shall be set free of inclosures.

(8) The entire house drainage system shall be so designed, constructed, and maintained as to conduct the waste water or sewage quickly from the fixture to the place of disposal, with velocities which will prevent clogging, fouling and the depositing of solids.

(9) The drainage pipes shall be so designed and constructed as to be proof for a reasonable life of the building against leakage of water or drain air due to defective materials, imperfect connections, corrosion, settlements or vibrations of the ground or building, temperature changes, freezing or other causes.

(10) The drainage system shall be provided with an adequate number of cleanouts so arranged that in case of stoppage the pipes may be readily accessible.

(11) Each fixture or combination fixture shall be provided with a separate accessible, self scouring reliable water seal trap placed as near to the fixture as practical.

(12) The house drainage system shall be so designed that there will be an adequate circulation of air in all pipes, no danger of siphonage, aspiration, or forcing of trap seals under conditions of ordinary use.

(13) The soil stack shall extend full size, upward through the roof terminal and have a free opening, the roof terminal being so located that there will be no danger of air passing from it to any window and no danger of clogging of the pipe by frost, or by articles being thrown into it, or of roof water draining into it.

(14) The plumbing system shall be subjected to a water or air pressure test, and to a final air pressure test if necessary, to disclose all leaks and imperfections in the work.

(15) No substances which will clog the pipes, produce explosive mixtures, or destroy the pipes or their joints, shall be allowed to enter the house drainage system.

(16) Refrigerators, ice boxes, or receptacles for storing food shall not be connected directly with the drainage system.

(17) No water-closet or urinal shall be located in a room or compartment which is not properly lighted or ventilated to the outer air.

(18) If water-closets or other plumbing fixtures exist in buildings where there is no sewer within a reasonable distance, suitable provision shall be made for disposing of the house sewage by some method of sewage treatment and disposal satisfactory to the health authority having jurisdiction.

(19) Where a house drainage system may be subjected to backflow of sewage, suitable provisions shall be made to prevent its overflow into the building.

(20) Plumbing systems shall be maintained in a sanitary condition.

H 62.02 Definitions. (1) **PLUMBING** means and includes: (a) All piping, fixtures, appliances and appurtenances in connection with the water supply and drainage systems within a building and to a point from 3 to 5 feet outside of the building.

(b) The construction and connection of any drain or waste pipe carrying domestic sewage from a point within 3 to 5 feet outside of the foundation walls of any building with the sewer service lateral at the curb or other disposal terminal, including private domestic sewage treatment and disposal systems and the alteration of any such system, drain or waste pipe, except minor repairs to faucets, valves, pipes, appliances and removing of stoppages.

(c) The water service piping from a point within 3 to 5 feet outside of the foundation walls of any building to the mains in the street, alley or other terminal and the connecting of domestic hot water storage tanks, water softeners, and water heaters with the water supply system.

(d) The water pressure system other than municipal systems as provided in ch. 144.

(e) A plumbing and drainage system so designed and vent piping so installed as to keep the air within the system in free circulation and movement, and to prevent with a margin of safety unequal air

pressures of such force as might blow, siphon or affect trap seals, or retard the discharge from plumbing fixtures, or permit sewer air to escape into the building.

(2) **ALIGNMENT.** Laid to a straight line, either horizontal, vertical or at a given angle.

(3) **APPROVED** means approval by the local plumbing or building supervisor or state board of health or industrial commission in conformance with the respective laws and regulations governing.

(4) **A.S.T.M.** Abbreviation for American Society for Testing Materials.

(5) **BACKFLOW** is a term which denotes the reversal of flow in a drainage system.

(6) **BASEMENT** means a story whose floor line is below grade at any entrance or exit and whose ceiling is not more than 5 feet above grade at any such entrance or exit. The first floor is the floor next above the basement, or the lowest floor if there is no basement. The number of stories of a building includes all stories except the basement.

(7) **BELL OR HUB.** That portion of a pipe which for a short distance is sufficiently enlarged to receive the end of another pipe of the same diameter for the purpose of making a joint.

(8) **BRANCH.** The branch of any system of piping is that part of the system, which extends laterally at a slight grade, with or without other lateral or vertical extensions, from the stack, building drain or building sub-drain to receive fixture outlets.

(9) **BURR.** Roughness or metal protruding from the walls of a pipe, usually as the result of cutting the pipe.

(10) **CATCH BASIN.** A water-tight receptacle built to arrest the sediment of surface subsoil or other waste drainage, and to retain oily or greasy wastes, to prevent their entrance into the house sewer or drain.

(11) **CLEANOUT.** A metallic plug or cover joined by means of a screw thread to an opening in a pipe, which can be removed for the purpose of cleaning or examining the interior of the pipe.

(12) **CODE.** A compilation of minimum rules and regulations governing the installation of plumbing, drainage and water supply.

(13) **CONDUCTORS, ROOF LEADERS, DOWN SPOUTS.** All pipes located in or outside of buildings, conveying storm or rain water from the roofs of buildings or areas to the storm or yard sewer, basin or rain-water cistern.

(14) **DEAD END** is that part or branch of a drainage system which is without a free circulation of air.

(15) **DRAINAGE DISPOSAL FIELD.** A shallow soil absorption system consisting of open jointed or perforated pipe for disposal of effluent or clear waste.

(16) **EFFLUENT.** Liquid flowing from any treatment tank or device.

(17) **EJECTORS.** An ejector is a device operated either electrically, or by water power or other mechanical means so constructed as to

elevate liquids from a lower level to a point of discharge into a public or private sewer or other final means of disposal.

(18) **FERRULE.** A metallic sleeve, used to connect lead or iron waste, or vent pipe, to a soil pipe hub.

(19) A **FITTING** is a device designed to make connections between pipes.

(20) **FIXTURES.** (a) A *fixture* is a receptacle intended to receive and discharge water, liquids, or water carried wastes into a drainage system.

(b) A *lavatory* or wash basin is a fixture designed for the washing of the hands or face.

(c) A *sink* is a shallow fixture ordinarily with a flat bottom, and usually used in a kitchen, or in connection with the preparation of foods.

(d) *Service sink* is a deeper fixture than a kitchen sink and used for the reception of slops.

(e) A *tray* is a fixture used in a laundry for washing; sometimes called a laundry tub.

(21) **FIXTURE UNIT** is any fixture or equivalent that discharges intermittently at the rate of 7.5 gallons per minute (one cubic foot per minute).

(22) **FREE CIRCULATION** of air means a plumbing and drainage system so designed and installed as to keep the air within the system in free circulation and movement, and to prevent with a margin of safety unequal air pressures of such force as might blow, siphon or affect trap seals, or retard the discharge from plumbing fixtures or permit sewer air to escape into the building.

(23) **GARAGES.** A public garage is a building or part of a building having more than 500 square feet in area which accommodates or houses self-propelled land, air or water vehicles.

(24) **HEIGHT OF BUILDING** is measured at the vertical center line of its lowest side from the street grade, or if setting back from street from grade of the ground adjoining the building, to the highest part of a flat roof or to a point two-thirds the height of a gabled or hip roof.

(25) **INDUSTRIAL WASTES.** The liquid wastes resulting from the processes employed in industrial establishments.

(26) **LONG SWEEP $\frac{1}{4}$ BEND.** A bend having the radius of the center line of the bend equal to 7 inches plus one-half the inside diameter of the pipe.

(27) **MANHOLE.** An opening constructed to a sewer or any portion of a plumbing system of sufficient size, to permit a man to gain access thereto.

(28) **PLACE OF EMPLOYMENT.** Every place, whether indoors or out, or underground and the premises appurtenant thereto, where either temporary or permanently any industry, trade or business is carried on, or where any process or operation, directly or indirectly related to any industry, trade or business, is carried on, and where any person

is directly or indirectly employed by another for direct or indirect gain or profit, but shall not include any place where persons are employed in private domestic service or agricultural pursuits, which do not involve the use of mechanical power.

(29) PRIVATE DWELLING is understood in this code to be any building used only for living purposes and occupied by not more than two families.

(30) PRIVY. An outhouse or structure used for the deposition of human excrement.

(31) PRIVY VAULT. A pit beneath a privy in which human excrement collects.

(32) PUBLIC BUILDING. Any structure used in whole or in part as a place of resort, assemblage, lodging, trade, traffic occupancy or use by the public, or by three or more tenants.

(33) REPAIRS AND STOPPAGES. Repairs are defined to consist of fixing leaks and removing of obstructions in soil, waste and supply pipes and to restore defective valves, faucets and similar appliances to an efficient operating condition.

(34) RISER is a water supply pipe which extends vertically one full story or more to convey water to branches or fixtures.

(35) ROUGHING IN is the installation of all soil, waste, vent and water supply pipes within a building.

(36) RURAL OR ISOLATED BUILDINGS are understood in this code to be those situated at such a distance from a public sewer system that their drainage systems cannot become tributary thereto.

(37) SAFING. A pan or other collector placed beneath a pipe or fixture, to prevent leakage from escaping on the floor, ceiling or walls.

(38) SEEPAGE PIT. An underground receptacle with a manhole and cover brought to the surface of the ground for observation and cleaning purposes, so constructed as to insure the disposal of effluent or clear wastes, by soil absorption through its walls and bottom.

(39) SEPTIC TANK is a reservoir or tank which receives crude sewage, and by bacterial action and sedimentation effects a process of clarification and decomposition of solids.

(40) SEWAGE. The water carried wastes created in and to be conducted away from residences, industrial establishments, and public buildings as defined in section 101.01, Wis. Stats., with such surface or ground water as may be present.

(41) SEWERAGE SYSTEM. All structures, conduits and pipe lines by which sewage is collected and disposed of, except plumbing inside and in connection with buildings served, and service pipes from building to street main.

(42) SEWERS. (a) A *combined sewer* is a sewer or drain intended to receive domestic sewage, industrial water-carried wastes, surface, storm and clear water.

(b) *Building or house drain*. The lowest main horizontal piping of a drainage system which receives the discharge of all soil, waste

and other drainage pipes inside any building and conveys the same to the building sewer, 3 to 5 feet outside the foundation wall of such building. The minimum building drain extends from the building sewer to the furthestmost soil stack. 1. Building or house sub-drain. The horizontal portion of a drainage system within a building which cannot flow by gravity to the building or house drain.

(c) *Building or house sewer.* That part of the horizontal piping beginning 3 to 5 feet from the foundation wall to its connection with the main sewer, septic tank, or other disposal terminal.

(d) A *private sewer* is a privately owned sewer.

(e) A *public sewer* is a publicly owned sewer.

(f) A *sanitary sewer* is a sewer or drain constructed to convey organic waste from buildings to a septic or other treatment tank or point of disposal and from which all surface and storm water is excluded.

(g) A *storm drain* is a conduit for carrying off surface, storm and clear waters.

(h) A *subsoil drain* is that part of a drainage system which conveys the ground or seepage water, from the foot of walls or below the cellar floor under buildings to the house or storm drain.

(i) A *yard drain* is that part of a horizontal piping and its branches which convey the surface drainage from areas, courts or yards, outside the walls of a building, to the house drain, house sewer or storm water drain.

(43) SHALL, SHOULD, AND MAY. The word "shall" when used in this code is mandatory. "Should" is not mandatory but expresses the recommendation of the board. "May" implies neither compulsion nor recommendation, only permission.

(44) SIPHONAGE. (a) *Siphonage* is a suction created by the flow of liquids in pipes.

(b) *Back siphonage* means the formation of a partial vacuum in water supply pipes which cause a sucking back of polluted water or other liquids into the water supply piping.

(45) SLIP JOINT is a connection in which one pipe slips into another, the joint of which is made tight with approved gasket or packing.

(46) SOIL STACK. Any pipe extending upward which conveys the discharge of water closets with or without other fixtures to the building drain, building sub-drain or underground branch.

(47) SPECIAL WASTE. Waste pipes which are not permitted to connect directly to the soil or waste stack, house drain or house sewer.

(48) SPIGOT is the end of a pipe or fitting which fits into bell or hub.

(49) STACK. The pipe extending upward from the building drain, building sub-drain or underground branch with or without change of direction through the roof or to a connection with another stack.

(50) SUMP. A collecting basin installed at the low point of a plumbing system to receive liquid wastes from which they may be ejected or pumped to a gravity sewer or waste pipe.

(51) **TERMINAL** is that part of a drainage or vent system which projects above the roof of the building or at the end of the house drain connecting to the septic tank or house sewer.

(52) **TRAPS.** (a) *Trap* is a fitting constructed to prevent the passage of air or gas through a pipe without materially affecting the flow of sewage or waste water.

(b) The *crown of a trap* is where the trap connects to or becomes a part of the horizontal outlet arm, and any portion of the horizontal outlet arm of the trap which is integral with the trap.

(c) *Deep seal* is a term applied to a trap having a water seal twice the depth of the common trap.

(d) *Depth of trap seal* is indicated by the height of the water column measured between the overflow and the dip separating the inlet and outlet arms of the trap.

(e) A *deep seal resealing trap* of the centrifugal self-scouring type is a trap in which the water motion is both centrifugal and upward at each discharge of the fixture and retains an adequate amount of water to form an efficient trap seal.

(f) A *drum trap* consists of a cylinder with its axis vertical. The cylinder is larger in diameter than the inlet or outlet pipe, it is usually 4 inches in diameter with one and one half or 2 inch inlets and outlets. A trap screw of the same size as the cylinder, accessible for cleaning purposes is provided.

(g) A *sand trap* is a catch basin for the collection of sand or other gritty material.

(53) A **VACUUM** is a pressure less than atmospheric pressure and is referred to sometimes as a suction. It is usually measured by the number of inches of mercury below atmospheric pressure, such as 10 or 20 inches of mercury. A perfect vacuum varies with the barometric pressure but in Wisconsin is equal to about 29 inches of mercury.

(54) **VENTS.** (a) *Vent pipe* is any pipe provided to ventilate a drainage and plumbing system of piping.

(b) *Back vent* is a pipe which connects directly with an individual trap, soil or waste pipe underneath or back of the fixture it serves and connects to the general vent piping system above this fixture with no part of it below the fixture trap.

(c) *Branch vent* is that part of the vent piping which extends horizontal, with or without lateral or vertical extensions, and to which other vent pipes connect.

(d) *Circuit vent* is a connection made by joining a nearly horizontal trap outlet with a soil or waste pipe, and vent pipe in such a manner that a continuous vent is formed.

(e) *Continuous vent* is a vertical vent pipe that is a continuation of the vertical waste pipe to which it connects.

(f) *Loop vent* is similar to a back vent except that part of it extends below the trap it serves before re-connecting to the vent system.

(g) *Main soil or waste vent* is that part of the stack above the highest installed branch or fixture connection.

(h) *Main vent* is a vent pipe extending vertically with or without changes of direction and which acts as a terminal for other vents, and terminates through the roof or connects with the main soil or waste vent at a point 2 feet or more above the highest soil or waste opening, but in no case less than 38 inches above the highest floor on which soil or waste openings are installed.

(i) *Relief vent* is a vent pipe connected close to the stack in a manner to prevent minus and plus pressures in the stack.

(j) *Unit vent* is one which denotes an installation so arranged that one pipe will serve two traps at the same point.

(k) *Wet vent* is that portion of a vent pipe through which liquid wastes flow.

(l) *Yoke vent*. A connection between a vent stack and a soil or waste stack in a manner to prevent minus and plus pressures in the stacks.

(m) *Local or exhaust vent* is a pipe or shaft conveying foul air from plumbing fixtures or rooms to the outside air and not connected to the plumbing system.

(55) **WASTE STACK OR PIPE AND LOCAL WASTE PIPE** is any pipe which receives the discharge of any fixture except water closets. When such pipe does not connect directly with a house drain or soil stack it is called a local waste pipe.

(56) **WATER SUPPLY.** (a) A *private water supply* is a privately owned supply not including any public utility or any water supply serving ten or more premises of mixed ownership.

(b) The *water service pipe* is the pipe from the water main, or private pumping system to the building served.

(c) The *water distribution pipes* are those which convey water from the service pipe to the plumbing fixtures.

(57) **WIPED JOINT** is the fusion of metal with solder, smoothly finished with a wiping cloth, and having a thickness of at least one-fourth inch, at the point where the pipes are joined.

(58) **WORKMANSHIP** is work of such character that will fully secure the results sought in all the sections of this code.

History: 1-2-56; (8), (42) (b) and (c); (46) and (49) am. Register, February, 1957, No. 14, eff. 3-1-57.

H 62.03 Fixture unit design basis. (1) **INTERMITTENT FLOW FIXTURES.** The fixture unit value and the size of traps, vents, and piping shall be as designated in the following table for any fixture named therein. Equivalent value for other intermittent operating fixtures shall be one fixture unit for each 7.5 gallons per minute of flow rate. (See table at top of page 211.)

(2) **CONTINUOUS FLOW FIXTURES.** Fixtures such as pumps, ejectors and compressors from which there is continuous or semi-continuous discharge shall have a fixture value of two for each one gallon per minute of flow.

Table referred to in H 62.03 (1):

Type of Fixture	Unit Value	Trap Minimum Size Inches	Soil or Waste Minimum Size Inches	Vent Minimum Size Inches
Bath Tub, all types*	3	1½	1½	1½
Bed Pan Washer	6	2	3	2
Bidet	4	2	2	1½
Cuspidor, fountain or dental	1	1¼	1¼	1¼
Dishwasher, residential	4	1½	1½	1½
Drinking Fountain	½	1¼	1¼	1¼
Floor Drain,				
2 inch	4	2	2	1½
3 inch or larger**	4	3	3	2
Laundry Tray	3	1½	1½	1½
Refrigerator, ice	½	1¼	1¼	1¼
Shower Stall, each head	4	2	2	1½
Sinks,				
combination	4	1½	1½	1½
factory wash-up	4	2	2	1½
fountain or bar	3	1½	1½	1½
glass or silver	3	1½	1½	1½
pack or plaster work	4	2	2	1½
residential	4	1½	1½	1½
restaurant, all types	4	2	2	1½
siphon jet	4	3	3	2
service sink, wall outlet	4	2	2	1½
service sink, floor outlet	4	3	3	2
surgeons wash-up	3	1½	1½	1½
Sterilizer,				
bed pan	4	2	2	1½
instrument or water	1	1¼	1¼	1¼
Urinal	4	2	2	1½
Wash basin	1	1¼	1½	1¼
Water Closet, any type	6	2	3	2

*Includes foot, Sitz and infant baths and regular bath tubs with or without shower.

**Trap and waste pipe sizes to correspond to floor drain when 4 inches or larger.

(3) UNIT CAPACITY AND LENGTH OF SANITARY PIPING. The number of fixture units connected to any stack, branch or vent and the length of piping shall not exceed that shown in the following table for a given diameter of pipe. After maximum length, including vent, for any given pipe size is reached, the diameter of the pipe shall be increased to the next size.

Pipe Diameter (inches)	Fixture Unit Capacity Soil, Waste or Vent Pipe			Maximum Length (in feet)
	On Stack	On Branch	On Vent	
1¼	1	1	1	50
1½	8	4	12	65
2	18	9	24	85
2½	40	20	60	105
3	84*	42	126	212
4	252	126	252	300
5	680	340	680	390
6	1,380	690	1,380	510
8	3,600	1,800	3,600	750
10	7,600	3,800	7,600	
12	12,000	6,000	12,000	

*See H 62.06 (2) on water closet limitations.

H 62.04 Building sewers. (1) PREMISES SERVED. The plumbing system of each new building, or a new plumbing system in an existing building, shall be entirely separate from and independent of that of any other building. Every building shall have an independent connec-

tion with a sanitary street sewer or sanitary main sewer when available. Private sanitary main sewers shall conform to specifications for public sewers and be approved by local authorities before installation.

(2) **MATERIALS.** All building sanitary sewers shall be constructed of cast iron, vitrified clay, concrete, asbestos cement pipe or other materials approved by the board for restricted, tentative or experimental use. See subsections H 62.15 (3) and (4); H 62.16 (1), (2), and (3); sections H 62.23, and H 63.01.

(3) **SLOPE.** Building sanitary sewers shall, where possible, have a slope of one-fourth inch per foot or more. In no case shall the slope of a building sanitary sewer be less than one-eighth inch per foot. Between the lot line and the street sewer, or riser pipe therefrom, the sewer shall be laid at a uniform slope not exceeding one-half inch per foot. Where the main sewer in the street has sufficient depth, or where a lot is 3 feet or more above the established grade line, the building sewer between the lot line and the building may receive greater inclination than one-half inch per foot as may be provided for by local ordinance, or as in the judgment of the authorized supervisor is acceptable.

(4) **SIZE.** (a) *Sanitary sewer.* The size of the building sanitary sewer shall be determined by the total number of fixture units tributary to such building sewer using the following table. The diameter of the building sewer shall be equal to or greater than that of the building drain. The minimum inside diameter of the building sanitary sewer shall be 4 inches.

Diameter of Pipe (inches)	Maximum Number of Fixture Units		
	$\frac{1}{8}$ " per ft. slope	$\frac{1}{4}$ " per ft. slope	$\frac{1}{2}$ " per ft. slope
4.....	115	150	210
5.....	270	370	540
6.....	510	720	1,050
8.....	1,290	1,860	2,640
10.....	2,520	3,600	5,250
12.....	4,390	6,300	9,300

(b) *Storm sewer.* The required size of building storm sewers, other exterior drains and lateral branches should be determined on the basis of the horizontal projection of roofs, yards and other tributary areas. A building storm sewer shall not connect to a building sanitary sewer. The building sanitary sewer and building storm sewer shall be installed separately and connected to the appropriate street or main sewer. In the event an existing adequate building sewer connects to a combined sewer or street sewer it may be continued in use as a common building sewer until such time as separation of storm water is accomplished. The size of interior roof leaders and building storm drains shall be determined on the total horizontal area to be drained thereby. The size of a smooth bore building storm drain or sewer should be at least equal to the size of a single vertical leader that would be required for the entire tributary area. The size of the vertical leader should be determined from the following table or be calculated using a formula which provides equivalent values.

Type of Roof	Allowable Roof Area in Square Feet for Given Size of Inside Leader					
	2½"	3"	4"	5"	6"	8"
Roof covered with gravel, slag or similar material with incline ¼" to 1' or less-----	Up to 1,645	1,646 to 2,120	2,121 to 3,780	3,781 to 5,885	5,886 to 8,490	8,491 to 15,125
Same with incline ½" to 1' or more and sawtoothed roofs-----	Up to 1,220	1,221 to 1,770	1,771 to 3,150	3,151 to 4,905	4,906 to 7,075	7,076 to 12,600
Metal, tile, brick, slate, or similar roofs of any incline-----	Up to 975	976 to 1,415	1,416 to 2,520	2,521 to 3,925	3,926 to 5,660	5,661 to 10,080

(5) ALIGNMENT. All building sanitary sewers shall be laid in alignment between fittings. Any changes in grade or direction shall be made with proper wyes or long radius fittings. Clipping of pipe or fittings is prohibited.

(6) INSTALLATION. (a) *Trenching*. All excavations shall be open trench work unless otherwise permitted by local ordinance or accepted by the local inspector.

Note: See sections Ind 6.06, 6.12 and 6.21 concerning timber requirements for trenches and general safety precautions.

(b) *Stable bottom*. Where the bottom of the trench can be maintained in a stable condition and free of water during time of installation of pipe, the building sanitary sewer, depending on the type of material used, shall be bedded and be initially backfilled as herein-after provided. Grade, as used in this subsection, is defined as the elevation of the bottom of the pipe.

1. Concrete, clay and asbestos-cement pipe. The trench bottom throughout its length shall be excavated to a depth at least 3 inches below the grade elevation and be brought back to grade with a sand, gravel, or crushed stone bedding which is tamped in place. The size of the bedding material shall be such that 100% shall pass a one-half inch sieve. The bedding shall be shaped to accommodate pipe bells or couplings. No planking or blocks shall be used to support the pipe. Initial backfill on the sides of the pipe and to a depth of 12 inches over the pipe for that portion of the building sewer located on private property shall be well tamped sand, gravel, crushed stone or excavated material which is neither corrosive nor organic in nature. The material shall be of such size that 100% shall pass a one-inch sieve. For that portion of the sewer located within the limits of the street, the initial backfill shall be sand, gravel or crushed stone of such size that 100% shall pass a one-inch sieve. Initial backfill shall be placed in increments not exceeding 6 inches in depth and be well tamped for the full length of the sewer.

2. Cast iron soil pipe. Where the trench bottom does not contain stone one inch or larger in size or where bedrock is not encountered, the trench for that portion of the sewer on private property may be

excavated to grade. When stone one inch or larger in size or when bedrock is encountered, the trench on private property shall be excavated to a depth at least three inches below the grade elevation and be brought back to grade with a bedding of sand, gravel, or crushed stone of which 100% shall pass a one-half inch sieve. The bedding material shall be tamped in place. Such three-inch deep bedding shall be used for that portion of the sewer located within the limits of the street. The bedding or trench bottom shall be shaped to accommodate the bells of the pipe. No planking or blocks shall be used to support the pipe. Initial backfill on the sides of the pipe and to a depth of 3 inches over the pipe for that part of the building sewer laid on private property shall be well tamped sand, gravel, crushed stone or excavated material which is neither corrosive nor organic in nature. The material shall be such that 100% shall pass a one-inch sieve. For that portion of the sewer in the street, the initial backfill material to a depth of 12 inches over the pipe shall be sand, gravel or crushed stone of such size that 100% shall pass a one-inch sieve. It shall be placed in increments not exceeding 6 inches and be well tamped.

(c) *Unstable bottom.* Where a mucky or unstable bottom is encountered in the trench, the required dry and stable foundation conditions shall be provided by sheathing driven and left in place to a depth of 48 inches below the trench bottom or to solid foundation at a lesser depth, the removal of wet and yielding material to a depth of 24 inches or to solid material, and replacement of the unstable material with limestone screenings, pea gravel or equivalent material for the bedding under the pipe. The trench bedding shall be shaped to accommodate pipe bells or couplings. In lieu of the foregoing, the required dry and stable foundation conditions may be provided by installation of a longitudinally reinforced concrete cradle at least 3 inches thick under the pipe, or by installation of a longitudinally reinforced concrete slab at least 3 inches thick and bedding material as provided for in subsection H 62.04 (6) (b) 1. Initial backfill material and its placement shall conform to that specified in subsections H 62.04 (6) (b) 1 and 2. All sheathing should be cut off at a depth of 3 feet or more below the ground surface to prevent heaving due to frost action.

(d) *Backfill completion.* Due care shall be exercised in placing the balance of the backfill to prevent breakage of the pipe. Large boulders or rock or concrete slabs, or frozen masses, shall not be used in the backfill nor shall machinery be operated within the trench until a cover of 6 feet over the pipe has been attained.

(e) *Inspection.* The building sewer shall be inspected upon completion of placement of the pipe and before backfilling. Upon request of the plumbing inspector, a tee shall be provided to permit testing the pipe for leakage or infiltration. Such tee, when used, shall be located as near as possible to the point of connection with the street or main sewer.

(7) **CONNECTIONS TO MAIN SEWER.** When a building connection on the street or main sewer is not found within 3 feet of the point designated by the local governing body, or its authorized representative, a "Y" or "T" fitting approved by the board shall be used. The connection shall be set upon or in a carefully cut opening centered in the upper quadrant of the street sewer, and be secured by encasement of

the main sewer pipe and the fitting with concrete at least 3 inches thick so as to assure permanency of connection and adequate backing of the street sewer pipe. In lieu of the use of fittings and in the event that the opening cannot be centered in the upper quadrant of the street sewer, a length of the street sewer pipe shall be removed and a "Y" branch section inserted in its place. The joints at the ends of such section shall be encased in concrete at least 3 inches thick. Such connection or insertion shall be made under the supervision of the authorized representative of the municipality. See subsection H 62.22 (2).

(8) **SEWER ENDS AND CONNECTIONS GUARDED.** The ends of all sanitary sewer pipes not immediately connected shall be securely closed so as to prevent the introduction of sand or earth or drainage from an excavation.

(9) **LIMITATION ON LOCATION.** The following minimum distances shall be maintained between building sewers and water wells:

- (a) Sewers of cast iron pipe—leaded joints—8 feet.
- (b) Sanitary sewers of material other than cast iron—25 feet.
- (c) Rain water drains or other clear water conductors—10 feet.

(10) **LIMITATIONS ON USE.** (a) *Sewers discharging objectionable liquids.* No person shall connect to a public sewer any sewer through which is discharged any substance likely to cause undue corrosion, obstruction, nuisance, explosion or interference with sewage treatment processes. See section H 62.11.

(b) *Storm and clear water connections prohibited.* Roof-leaders, surface drains, ground water drains, foundation footing drains, and refrigerator cooling water drains shall be connected wherever possible with a storm sewer, but they shall not be connected to a building sewer which discharges into a sanitary sewer or private sewage treatment plant. Air conditioning and clear water drains not described herein shall also discharge to storm drains or sewers unless special permission is obtained from the board by the local authority.

History: 1-2-56; am. (10) (b), Register, February, 1957, No. 14, eff. 3-1-57; am. Register, August, 1961, No. 68, eff. 9-1-61.

H 62.05 Building drains. (1) **ELEVATION.** All building drains shall be brought into the building underground, preferably below the level of the basement floor.

(2) **MATERIALS.** All building drains shall be constructed of vitrified clay, type L hard temper copper or cast iron pipe. The use of vitrified clay is permitted only where there is a soil covering of 18 inches or more or where the pipe is covered with 12 inches of soil and a substantial concrete floor. Where a building drain leaves the building at a point above the basement floor, it shall be constructed of cast iron or type L hard temper copper pipe to a point 5 feet from the inside of the building foundation wall or to such additional distance as necessary to reach undisturbed stable ground. See subsection H 62.22 (3).

(3) **SIZE.** The size of building drains and building sub-drains shall be determined by the number of fixture units tributary thereto. The minimum size of a building drain shall be 4 inches. The minimum size

of an underground building sub-drain shall be 3 inches. See subsections H 62.04 (4) (a) and H 62.10 (1).

(4) **BACKFLOW VALVES.** Building drains when subject to backflow or backwater at the time of installation, shall be provided with adequate backwater valves, installed to prevent interference with the flow or discharge of any fixture, and be readily accessible for cleaning. Provisions for a free circulation of air shall be made.

(5) **OTHER REQUIREMENTS.** Installation of building drains shall also conform to subsection H 62.04 (3) as to slope, subsections (5), (6), (8), (9) and (10); sections H 62.15 and H 62.16, insofar as they are applicable and necessary for proper installation.

History: 1-2-56; am. (1), (2) and (3), Register, February, 1957, No. 14, eff. 3-1-57; am. Register, August, 1961, No. 68, eff. 9-1-61.

H 62.06 Stacks and branches. (1) **SOIL AND WASTE STACKS.** Every building in which plumbing fixtures are installed shall have a soil, waste or vent stack at least 3 inches in diameter extending through the roof with an increaser or frost proof housing. See subsections H 62.07 (12), H 62.22 (4), (5), (6), (7).

(2) **SIZE.** The size of the stacks and branches shall be determined by the number of fixture units connected thereto. If pitch or grade of a soil or waste branch is 45 degrees or more, the same unit capacities as for vertical stacks will be permissible. Any underground branch shall be at least 2 inches in diameter. A water closet may connect to a 3 inch stack through a 4 x 3 inch bend. Not more than two water closets shall be connected to a 3 inch soil stack. Not more than one water closet shall be connected to a 3 inch branch. Two water closets located back to back shall be connected to a 3 inch soil stack with a 3 x 3 inch double wye and one-eighth bends or similar fittings or fitting. A sanitary cross will not be permitted. All waste openings provided for future use shall be properly vented and sealed. See subsections H 62.03 (1), (3).

(3) **STACK CONNECTION AT BASE.** A long sweep one-fourth bend, two one-eighth bends, or a "Y" and one-eighth or one-sixth bend or its equivalent shall be used at the base of all soil and waste stacks. When such bend or fittings constitute the connection between a soil or waste stack and an underground house drain or branch of larger size than the soil or waste stack served, the increase shall be made above the floor unless a special approved fitting is used. See subsections H 62.22 (8), (9).

(4) **MULTIPLE BUILDING STACKS.** Where more than one unit in a motel, cabin court or mobile home park are connected to the same sewer or drain, a minimum vent stack of 2 inches may be permitted in each unit when the total number of fixture units does not exceed the capacity of such 2-inch pipe, provided that a full sized 3-inch stack is installed in the uppermost unit or at the upper end of the sewer. In the latter case the stack shall have frost protection. See subsections H 62.07 (12) (a).

(5) **BRANCHES.** (a) *Soil and waste extensions.* Any branch extending from a soil or waste pipe, running vertically, horizontally, or both, shall be carried full size to fixture connections and shall

be vented or revented to conform with the provisions of H 62.03 (1) and (3). See subsections H 62.22 (11), (12).

(b) *Grade of horizontal pipes.* All horizontal drain, soil and waste pipes shall be run in practical alignment, and where possible at a uniform grade of one-fourth inch per foot or more. In no case shall the grade be less than one-eighth inch per foot.

(c) *Change in direction.* All changes in direction shall be made by the proper use of 45 degree "Y"s, half-"Y"s, long sweep one-fourth bends, one-sixth, one-eighth or one-sixteenth bends, or with fittings producing a like radius, except that single or double sanitary "T"s may be used on vertical stack or on horizontal runs where it is impracticable to install a 45 degree "Y" with a one-eighth bend. Short one-fourth bends may be used in soil and waste lines where the change in direction of flow is from the horizontal to the vertical and for closet discharge connections. No common pattern double sanitary "T", "Y" or straight through fitting shall be used on either a vertical or horizontal stack or branch, serving wall-hung closet bowls installed back to back. See subsections H 62.06 (2), H 62.14 (10), H 62.15 (5) (a).

(6) HANGERS AND SUPPORTS. Stacks shall be substantially supported at 10 foot or floor intervals. Horizontal piping shall be supported at intervals not to exceed 10 feet. Cast iron soil pipe shall be supported at intervals of not more than 5 feet. All pipe supports shall be heavy iron posts, wall hangers or bracket, or concrete or masonry piers. Supports secured in or against masonry shall be attached with expansion bolts or other approved methods without the use of wood plugs. All drainage and plumbing pipes shall be rigidly secured and supported so that proper alignment will be retained. See subsection H 62.22 (9).

(7) INCREASERS AND REDUCERS. Where different sizes of pipes or pipes and fittings are to be connected, proper size increasers or reducers shall be used.

(8) MATERIALS. All main branch, soil and waste pipes shall be made of cast iron, coated with tar or asphaltum, galvanized wrought iron or galvanized steel pipe, or lead, brass, or type M hard temper copper. All piping, other than cast iron pipe, when installed so as to be embedded through concrete, shall be protected by thoroughly applying one or more coats of asphaltum paint or adequate tar paper wrapping or both, or by other equivalent means of insulation. No galvanized steel or wrought iron waste pipes shall be laid underground.

(9) PROTECTION FROM FROST. All drain, soil, or waste pipes shall, unless entirely impracticable, be placed within the walls of buildings and shall be as direct as possible and shall together with all fixture traps and other appliances be protected from frost. Wherever soil and waste pipes are placed in outside walls, protection from frost shall be provided by adequate insulation which may consist of proper air spacing, approved insulating materials, warm air circulation or any effective combination of the same. The underfloor work of bath rooms located on outside walls, shall be protected from frost by

the placing of cold air draft stops between joists or studdings, or by the use of approved insulating materials.

History: 1-2-56; (2) am. Register, February, 1957, No. 14, eff. 3-1-57.

H 62.07 Vents. (1) **MAIN VENT.** All soil or waste stacks, 3 inches or more in diameter with fixtures on three or more floor levels, shall have the main vent connect full size to the main soil or waste pipe, below the lowest fixture branch.

(2) **CIRCUIT VENTS.** (a) *Water closets.* Circuit vents for water closets shall have a diameter of 2 inches for a battery of two closets, 3 inches for a battery of three to six closets and 4 inches for a battery of seven or eight closets.

(b) *Other fixtures.* The size of circuit vents shall be determined from the number of fixture units connected thereto. The size of the soil or waste branch shall be carried full diameter to the last fixture connection. A branch soil or waste pipe, to which two and not more than eight fixtures are connected may be vented by a circuit vent which shall be taken off ahead of the last fixture. See subsections H 62.03 (1), (3), H 62.22 (10), (11), (12), (24).

(c) *Relief vents.* Where fixtures discharge above a soil or waste pipe served by a circuit vent each such pipe shall be provided with a relief vent in the form of a wet or dry vent, taken off ahead of the first fixture, with a diameter of not less than one-half the size of the soil or waste stack. No relief vent shall be less than one and one-half inches in diameter. See H 62.22 (10), (11), (12).

(3) **YOKE VENT.** All main soil and waste pipes, in buildings over five floors in height, shall be provided with yoke vents at each five floor intervals. The size of such vents shall be equal to the size of the main vent pipe.

Note: Compute floor levels from top floor down. See H 62.22 (12).

(4) **UNIT VENT.** Two sinks, basins, baths or any like fixtures located on the same floor discharging into a double "Y" or sanitary tee-cross may be vented by a single vent pipe. Where bath rooms, water closets or other fixtures are located on opposite sides of a wall or partition in the same building, or are directly adjacent to each other, such fixtures may have a common soil or waste pipe and vent pipe stack. See H 62.06 (2), H 62.22 (13), (14).

(5) **CROWN VENT.** In no case shall a vent be taken off from the crown of a trap. See H 62.22 (19).

(6) **DISTANCE FROM TRAP.** Any vent pipe serving a fixture trap shall be connected as close to the trap as possible, but in no case shall the distance between the vent and trap be more than 24 times the inside diameter of the soil or waste pipe. This distance may be doubled where a drum trap is installed to serve a bath tub. The total grade of the soil or waste pipe shall not exceed the inside diameter of the pipe. See H 62.08 (1), (4) (c), H 62.22 (6), (7), (15), (19).

(7) **BACK VENTS, NOT REQUIRED.** (a) *Water closets and other fixtures.* Floor outlet water closets or other fixtures, not to exceed two, located on the same floor discharging into a vented double "Y" or sanitary tee-cross with no other fixtures discharging into the same

pipe above them need not be individually back vented, providing the developed distance of the horizontal soil or waste pipe does not exceed 24 times the inside diameter of the pipe and the total grade does not exceed the inside diameter of the pipe. The vertical leg between the horizontal soil pipe and the water level of the water closet shall not exceed 3 feet. See H 62.06 (2), H 62.22 (13).

(b) *Basement fixtures.* Water closets, not to exceed two in number, floor drains, subsoil traps, elevator catch basins or similar receptacles located in a basement need not be back vented when branched into underground horizontal drains or branches. Where a soil or waste pipe stack 3 inches or larger in diameter is involved, the branch connection shall be located 8 feet or more in the direction of flow from the base of such stack. The developed distance of the horizontal waste branch shall not exceed 48 times the inside diameter of the pipe. See H 62.22 (6), (7).

(8) *WET VENTS.* Where wet vents are used, all fixtures must be located on the same floor level including the fixture creating the wet vent excepting for installations covered by H 62.22 (5), (16), and (35).

(9) *REARRANGING OF VENT AND REVENTS.* Where fixtures are afterwards installed on a soil or waste line above a point where the vent or revents enter the vent or vent stack, the vent and revent pipes of the fixtures already installed shall be rearranged to conform to the provisions of this code.

(10) *VENT PIPE GRADES AND CONNECTIONS.* All branch vent and back vent pipes shall be free from drops or sags, and shall be so graded and connected as to drain back to the soil or waste pipe by gravity. Whenever it becomes necessary to trap a horizontal vent pipe, it shall be drained back into a waste pipe by gravity. See H 62.22 (17).

(11) *VENT CONNECTIONS.* All vent pipes shall be run separately through the roof; be connected to other vent pipes or vent stacks a minimum of 12 inches below the roof; or be reconnected to the main vent pipe not less than 38 inches above the highest floor on which fixtures are installed. No fitting or fittings for future waste connections shall be placed in any soil or waste pipe above the point of revent connection. See H 62.22 (18).

(12) *ROOF TERMINALS.* (a) *Size.* Any vent pipe extending through a roof shall be at least 4 inches in diameter beginning at a point 6 inches or more below the roof boards unless a smaller diameter vent pipe is protected by a frost proof hood approved by the board. See H 62.16 (9).

(b) *Location.* The roof terminals of all vent pipes shall be extended at least 3 feet above any door, window, scuttle, air shaft or other opening used for ventilation when located at a distance less than 12 feet from such terminal. When it is necessary to extend the roof terminals of soil, waste or vent pipes more than one foot above the roof, they shall have an adequate frost-proof covering. Whenever a new building is erected higher than an adjacent existing building, the owner of the new building shall not locate windows within 12 feet of an existing vent stack on the lower building. See H 62.22 (18).

(13) *MATERIALS.* The materials used for vent pipes shall comply with H 62.06 (8). See H 62.14 (10).

(14) PROTECTION FROM FROST. All vent pipes shall be protected from frost as provided for in H 62.06 (9).

History: 1-2-56; (7) (b) am. Register, February, 1957, No. 14, eff. 3-1-57.

H 62.08 Traps. (1) TRAPS REQUIRED. Each fixture shall be separately trapped by a water seal trap, placed as near to the fixture as practical, except that laundry trays, wash tubs or double compartment sinks may waste into single traps. The use of "S" traps to the floor is prohibited. See H 62.22 (19).

(2) TRAP SIPHONAGE. Every fixture trap seal shall be protected to prevent siphonage or back pressure by insuring air circulation with a vent or back vent. In no case shall a vent be connected at the crown of a trap.

(3) TRAP CONSTRUCTION. (a) *Design.* No trap which depends upon the action of movable parts for its seal shall be used. No trap shall be used which depends upon concealed interior partitions for its seal unless such interior partitions are made of indestructible material. No trap shall be used which in case of defect, would allow the passage of sewer air. No rubber or wicking packed slip joint connection shall be installed on the sewer side of a fixture trap. Unions on the sewer side of the trap shall be ground faced or equal, and shall not be concealed or enclosed. See H 62.22 (19).

(b) *Cleansing.* Every trap shall be self cleaning. Floating and sedimentary solids in the seal of the trap shall be removed by a normal discharge from the connected fixture. Uniform diameter traps shall be considered self-cleaning.

(c) *Material.* The material for traps shall be either vitreous china, clay, lead, brass, cast iron or malleable iron. Cast iron traps shall be coated on the inside and outside with an approved rustproof coating.

(d) *Depth of seal.* The water seal of all fixture traps shall be at least 2 inches. A deep seal trap shall have a water seal of 4 inches.

(e) *Approval.* Every trap shall have the maker's name, or registered trade mark, cast or stamped upon the exterior surface thereof. Traps varying from standard design shall have the approval of the board before being used in any installation. See H 62.15 (10) (d).

(4) TRAP INSTALLATIONS. (a) *Setting of traps.* All traps shall be so located as to be accessible, rigidly supported and set true with respect to their water level and so located as to protect their seals. See H 62.07 (6).

(b) *Traps where prohibited.* No fixture shall be double trapped and there shall be no traps at the base of soil or waste stacks.

(c) *Bath and shower traps.* Drum traps not less than 4 inches in diameter and having a seal of not less than 2 inches, should be used under all bath tubs and shower baths wherever practicable. See H 62.07 (6).

(d) *Deep seal traps.* Deep seal resealing traps of the centrifugal, self-scouring type may be used when a common trap is not adequate protection against sewer air, or when it is impractical to provide a proper back vent. So far as practical a free circulation of air shall

be provided. Traps of this type shall not be permitted in new construction.

(e) *Traps for rain water leaders.* One trap may serve for one or more rain water leaders. When rain water leaders are carried up to the roof of a building they need not be provided with traps, unless such conductors terminate within 12 feet of any door, window, ventilating hood or air intake. All conductor traps shall be provided with cleanout connections on the outlet side. Such cleanout shall be extended 2 inches or more above floor or grade level wherever practical. Traps may not be required when connected to a storm sewer.

(5) MAIN HOUSE TRAP. (a) *Location.* The main house drain may be provided with a horizontal trap set level and placed immediately inside the foundation wall where the sewer enters the building. This trap shall be provided with a 4-inch or larger screw thread cover cleanout. Main house traps may be removed in existing buildings where the roof terminals of conductors, soil and vent stacks are favorably located, when plumbing is free from defects, fixture traps properly protected from siphonage, and the installation made in a durable and sanitary manner, as provided for in this code. When main house traps are used they shall be provided with a fresh air inlet. See H 62.22 (21).

(b) *Fresh air inlets.* A fresh air inlet shall be connected on the house side at least 2 feet from the water seal of the main trap. The inlet when exposed shall be covered with a substantial fresh air cap or return bend. When located under a porch a free circulation of air shall be provided. No fresh air inlet shall be so placed that a cold air intake for a furnace or heater may draw air from the same; nor shall it be open at a point less than 4 feet from any door, window or other air intake.

H 62.09 Cleanouts. (1) PIPE CLEANOUTS. (a) *Size.* Cleanouts shall be the same size as the pipe up to 4 inches in diameter and not less than 4 inches for larger pipe. See H 62.22 (16).

(b) *House drain.* A 4-inch cleanout with brass screw cover, shall be provided at a point where the house drain leaves the building. This cleanout shall be extended from the house drain with a cast iron soil pipe to the surface of the finished floor or grade and wherever practical shall be not less than 2 inches above the finished floor or grade. Where the house drain or a branch to a soil or waste stack exceeds 25 feet in length an additional cleanout shall be provided for such soil or waste stack located at a point 28 to 30 inches above the floor. See H 62.09 (3), H 62.22 (21), (22).

(c) *Toilet and washrooms.* Cleanouts shall be provided in connection with batteries of water closets, urinals, wash basins, sinks and showers, at such points that all parts of the branch waste and soil pipes may be reached conveniently for cleaning or removal of stoppages.

(d) *Sink wastes.* Waste pipes from sinks or other similar fixtures, discharging greasy wastes, shall have sufficient accessible cleanouts spread over their entire length.

(2) TRAP CLEANOUTS. All fixture traps shall be so designed and installed that stoppages may be removed. All small fixture traps shall

be provided with cleanouts of the screw plug or removable dip type. Where the "U" or dip is removable the coupling nut on the discharge side shall be within the dip of the trap. Traps for urinals rising from the floor and traps serving shower baths and floor drains, when inaccessible, shall be so installed as to make the removable inlet serve as a cleanout. See H 62.22 (20), (31).

(3) CONSTRUCTION. The bodies of cleanout ferrules shall be made of cast iron or brass and shall extend not less than one-fourth inch above the hub receiving it. When solid brass screw caps for cleanouts are used, they shall be at least three-sixteenths inch in thickness and provided with standard pipe threads and one inch square or hexagonal solid head at least three-fourths inch high or adequate inverted countersunk sockets. The ferrules when constructed of brass shall be at least three-sixteenths inch in thickness; and when constructed of iron the same weight per foot as for cast iron soil pipe. The screw thread shall have at least five threads of iron pipe size. The tops of cleanout plugs shall be tool faced to a flawless smooth surface and so as to insure a tight joint. A cleanout with an approved ground joint, poured lead or equal metal seat between a brass or cast iron cover and the ferrule may be used. A brass plug of standard pipe size shall be used where cast iron threaded drainage fittings serve as cleanout openings.

H 62.10 Floor drains. (1) FLOOR DRAINS, TRAPS AND BACKWATER VALVES. All floor drains connecting directly to an underground building drain, building subdrain or branch shall connect into a cast iron deep seal trap not less than 3 inches in diameter, so constructed and installed that it can be readily cleaned. The drain inlet shall be so located that it is at all times in full view. When subject to back flow such drains shall be equipped with an adequate back water valve. Refrigerator drains, bubbler and similar wastes may be connected with a floor drain only in the manner set forth in H 62.14 (3), (5) and H 62.22 (34), (35).

(2) FLOOR WASTES FROM LAUNDRIES AND SIMILAR ESTABLISHMENTS. Waste pipes in dye houses, breweries, bottling works, creameries, laundries and similar establishments may discharge directly onto a nonabsorbent floor provided with an adequate number of floor drains. Where necessary to prevent discharge of coarse materials to a sewer system, suitable screen or catch basins shall be provided. See H 62.22 (24), (25).

(3) ICE-HOUSE AND STORAGE DRAINS. The floor drains in ice-house and refrigerator rooms, markets, slaughterhouses, storage rooms, or any rooms where ice is stored or used shall be of adequate size, properly trapped, and when necessary discharge into a catch basin. The inlet to such floor drains shall be in plain view at all times.

(4) SUBSOIL, TRAP RECEIVER. The discharge of drain tile from footings of buildings shall be collected in a subsoil receiver or trap when direct discharge to the ground surface is impractical. A trap receiver shall have a cleanout brought to the surface of the floor. A combination floor and subsoil drainage receiver may be used. All subsoil drainage outlets where connected to a sump, building drain or sewer shall be equipped with an effective back water valve. Foundation drains shall not be connected to sanitary sewers. See H 62.22 (26).

(5) AREA AND COURT DRAINS. When permitted to connect to the building or house drainage system the various drains from small yards, areas and courts may be connected together and their contents discharged into a yard catch basin, an adequate basement floor drain or a deep seal trap, so located that it is readily accessible for cleaning and is protected from frost. The surface opening of the drain to catch basin must be provided with an adequate strainer, and where necessary with a backflow valve. See H 62.04 (10) (b).

History: 1-2-56; (1), (4) and (5) am. Register, February, 1957, No. 14, eff. 3-1-57.

H 62.11 Catch basin, sumps, ejectors. (1) CONSTRUCTION OF CATCH BASIN. Catch basins shall be constructed in a water tight and substantial manner of brick, cement, concrete, cast iron, bitumastic enamel coated 14 gauge steel or wrought iron or vitrified clay pipe. The outlet shall be provided with a cast iron sanitary tee not less than 4 inches in diameter and be submerged not less than 6 inches below the flow or water line. A 4-inch cleanout shall be provided on the tee. The basin shall have a stone, cement or cast iron cover. No catch basin shall be located within 25 feet of any well. Catch basins shall be constructed according to the use for which they are intended. When connected to a sanitary sewer they shall be located and designed so as to exclude storm water.

(2) GREASE SEPARATORS. (a) *When required.* Grease catch basins or interceptors of a capacity based upon the temperature and amount of water tributary shall be installed wherever kitchen or other greasy wastes from hotels, restaurants, club houses, boarding houses, public institutions, hospitals or other similar places are discharged into a house drain or sewer. Garbage disposal units should not be tributary to catch basins or interceptors.

(b) *Location.* Whenever possible, grease catch basins shall be installed outside the wall of the building, as near as possible to the fixtures from which it receives the discharge. Such basin shall be protected against freezing. See H 62.22 (27), (28).

(c) *Capacity.* The liquid content capacity in gallons shall be not less than the flow tributary during any one hour, based upon an allowance of from 2 to 4 gallons of waste water per meal served.

(d) *Construction.* Grease catch basins shall be constructed in the same general manner as provided for catch basins. The inlet and outlet shall be placed as far apart as possible and the depth below outlet flow line shall be not less than 2 feet. The inlet shall not be submerged, and not be more than 12 inches above the flow line of the outlet invert. Grease catch basins when located inside of buildings, shall be provided with a removable air-tight stone, cement or cast iron cover. When bolted covers are provided, the bolts shall be of a non-corrosive metal. See H 62.22 (27).

(e) *Commercial interceptors.* Grease basins of this type shall have sufficient capacity, and be properly installed and maintained so they will serve the purpose for which intended. Iron grease traps shall be made of not less than 12 gauge copper bearing steel, pure iron or cast iron. Manufacturers ratings will be acceptable when approved by the board.

(f) *Maintenance.* Cleaning and removal of grease, sediment, or foreign matter which may prevent the satisfactory operation of the interceptor or basin, shall be performed at intervals of such frequency as to prevent the entrance of grease or foreign matter into the drainage system.

(3) **YARD CATCH BASINS.** A yard catch basin shall be constructed in the same general manner as provided for catch basins; they shall be at least 24 inches in diameter, and where possible the outlet shall be at least 4 feet below the surface of the ground or as nearly so as grade of house drain will permit. The outlet invert shall be submerged not less than 6 inches below the water line. The flow or water line shall not be less than 2 feet above the bottom. A yard catch basin may be installed to receive surface drainage or discharge from a pump, hydrant or other outside areas. It may connect only with a storm or combination sewer. See H 62.22 (29).

(4) **STABLE CATCH BASINS.** When liquid wastes from barns, stables, manure pits, and yards are permitted to enter the public sewer system, they shall be intercepted by a catch basin. See H 62.22 (29).

(5) **GARAGE REFUSE SEPARATORS.** (a) *Where required.* All liquid wastes, sand and grit from public garages, service pits and paved areas adjoining service pits, which come in contact with kerosene, gasoline, benzine, naphtha or other inflammable oils or compounds, shall be intercepted before entering the house drain or sewer, by an approved catch basin properly trapped. Gasoline and oil interceptors approved by the board may be installed.

(b) *Capacity.* Garage catch basins or sand traps shall be of a size sufficient to retain the sand and dirt washings reaching the basin during any 10-hour period. The basin shall have a minimum width of not less than 24 inches, and a depth below the water level of not less than 24 inches. See H 62.22 (30).

(c) *Construction.* Construction of garage catch basins or sand traps, shall conform to general requirements for catch basins. The outlet invert shall enter the walls of the basin so that the space between the water line in the basin and the floor level shall not exceed 10 inches. The outlet shall consist of a cast iron sanitary tee laid horizontally with a depth of invert of not less than 6 inches below the water line. The invert shall be provided with a 4-inch cleanout. An open bar strainer not less than 16 inches in diameter shall be provided. Where it is impractical to keep the outlet within 10 inches of the floor level a greater distance will be permitted. In all such installations a 4-inch local vent pipe shall be provided. Such local vent pipe shall enter the basin above the water line. Same shall terminate through roof or with a return bend outside of the building not less than one foot above the grade level. Where a vertical local vent pipe is installed, properly intercepted floor drains will be permitted to be connected thereto provided the total distance does not exceed 50 feet. Conductors or rain water leaders will not be permitted to act as local vent pipes.

(d) *Cleaning.* Garage catch basins or interceptors shall have the accumulated oil, gasoline or other inflammable fluids, sand, silt or other solids removed at regular intervals.

(6) **SUMPS.** (a) *Location.* All house drains discharging below the flow line of the main sewer, shall discharge into an air and water

tight sump or receiving tank, so located as to receive the drainage by gravity, from which sump or receiving tanks the drainage shall be lifted and discharged into the house drain or sewer by pumps, ejectors or any equally efficient method. All sumps installed for the purpose of receiving clear water, basement or foundation drainage water, sink or laundry tray waste shall be located at least 15 feet from any water well. All other sumps shall be located at least 25 feet from any water well.

(b) *Capacity.* The capacity of a sump or receiving tank shall be determined by computing all possible drainage tributary to the sump, including foundation drainage, boiler blowoffs, basement areas to be drained, depth of basement below house drain outlet, locations near a river or lake, soil conditions and types and number of fixtures.

(c) *Air inlet.* Any sump receiving domestic wastes shall have a fresh air inlet. The size of the air inlet pipe required will depend upon the size of the sump, varying from 2 inches to 6 inches. The air inlet pipe may be connected to a plumbing system vent pipe or extended separately to conform with the provisions of this code.

(d) *Vent.* The drain leading to a sump or receiving tank shall, when a closet or closets are installed, be provided with a vent stack not less than 3 inches in diameter. Where fixtures other than closets are installed the vent pipe size shall be determined from the tables in H 62.03 (1) and (3).

(7) **EJECTORS.** (a) *Where required.* In all buildings in which the whole or a part of the plumbing and drainage system lies below the flow line of the main sewer, the sewage, house wastes, foundation drainage, and seepage, shall be lifted by mechanical means, and discharged into the main sewer, house drain or house sewer, or properly trapped fixture.

(b) *Size.* The size and design of an ejector pump shall be determined by the capacity of the sump to be served, the discharge head and discharge frequency. Manufacturers ratings may be used.

(c) *Discharge connections.* The discharge pipe from the ejector to the building drain shall be connected through a branch Y fitting. The drain into which the ejector discharges shall be of sufficient size to receive the combined flow from the building and the ejector. Flanged connections and long radius fittings should be used.

(d) *Check valves.* Horizontal check valves shall be installed in each discharge line. Such valves may be omitted where the discharge pipe forms a loop 2 feet or more above the building drain and is provided with an adequate vent pipe to break the siphon action. When the drain is subject to backflow a check valve shall be used.

(e) *Fixture connections. Venting.* Fixtures located on a house drain near the point where such house drain receives the discharge from an ejector shall be effectively protected against siphonage, and an additional air relief or vent pipe shall be provided where necessary. No fixtures shall be connected to the discharge pipe from an ejector, between the ejector and the point where it enters the house drain or sewer.

(f) *Maintenance.* All such ejectors and like appliances shall receive care as needed to keep them in a satisfactory operating condition.

H 62.12 Fixtures. (1) **CONSTRUCTION AND MATERIALS.** All plumbing fixtures shall be of such design, materials and construction as to insure durability, proper service, sanitation, and so as not to entail undue efforts in keeping them clean, and in proper operating condition. See H 62.17.

(2) **INSTALLATION.** All plumbing fixtures shall be installed in a manner to afford easy access for cleaning. Enclosures under or around fixtures shall be provided with a circulation of air. Where practicable all pipes from fixtures shall be run to the wall. Back-grounds, except under special conditions shall be provided for the securing of closets, tanks, basins, sinks, brackets and all other wall fixtures or hangings.

(3) **FIXTURE OUTLETS.** Outlet passageway shall be free from impairments and of sufficient size to insure proper discharge of the fixture contents, under normal conditions. Outlet connections shall be such that a permanent air and water-tight joint can be readily made between the fixture and drainage system.

(4) **BATHTUBS, BASINS, SINKS, LAUNDRY TRAYS.** All such fixtures shall be made of earthenware, vitreous chinaware, enameled iron ware or other impervious material. Sinks and laundry trays may be made of other materials where conditions make it necessary. Wooden trays or sinks with or without metallic lining shall be allowed only in public laundries and dye houses where such fixtures are in daily use. Sinks or trays made in an approved manner of heavy black or galvanized iron may be used for special purposes.

(5) **SHOWER BATHS. SAFING.** All shower baths except those directly over unexcavated portions of a building, or where a shower receptacle is used, shall be safed with sheet lead or other noncorrosive material beneath the entire shower stall and upward along the sides of the stall for a distance of at least 6 inches. The safing shall be properly drained and coated with asphaltum.

(6) **DRINKING FOUNTAINS.** All drinking fountains shall be made of earthenware, vitreous chinaware, enameled iron ware or other impervious material. The bowl shall be so designed and proportioned as to be free from corners that it may be readily cleaned, and so as to prevent unnecessary splashing at the point where the jet falls into the bowl. The nozzle shall be of non-oxidizing impervious material and shall have no fouling space or enclosures making cleaning difficult or inducing insanitary conditions. The jet shall be inclined and the orifice shall be higher than the rim of the waste water receiving bowl. Drinking fountains shall not be installed in toilet rooms. The water supply shall be provided with an adjustable valve fitted with a loose key or an automatic self closing valve permitting regulation of the rate of flow of water. The water supply issuing from the nozzle shall be of sufficient volume and height so that persons using the fountain need not come in direct contact with the nozzle or orifice. To accomplish this it is recommended that the fountain supply be equipped with an efficient automatic pressure and volume regulating valve.

(7) **FLOOR DRAINS AND SHOWER DRAINS** shall be considered a fixture and be provided with a strainer.

(8) CLOSETS. (a) *Water-closets.* All water-closets shall be made of vitreous chinaware. The bowl and trap must be made of the combined pattern in one piece. They shall hold a sufficient quantity of water and be of such shape and form that no fecal matter will collect on the surface of the bowl. All water-closet bowls shall be equipped with adequate flushing rims, so as to flush and scour the bowl properly when discharged.

(b) *Frostproof closets.* Frostproof closets will be permitted in buildings when extreme conditions necessitate their use. When installed, the bowl must be of vitreous chinaware or cast iron enamel of the flush rim pattern provided with an adequate tank automatically drained. The soil pipe between the hopper and the cast iron trap shall be of 4-inch cast iron, free from offsets and only of sufficient length to protect the trap against frost; but in no case shall the soil pipe between the trap and hopper bowl be more than 6 feet in length.

Note: The water flushing device must be such as to meet the requirements prescribed in H 62.19. The installation and use of the frostproof type of fixture is to be discouraged as much as possible. Under the most favorable conditions little can be said for this closet from a practical and sanitary standpoint.

(c) *Range closets.* Range closets may be installed for temporary or infrequent use only, and in such situations that the range closet will not be in use more than 30 days in any year. Range closets shall be made of cast iron with all surfaces either porcelain enameled or coated with a non-corrosive paint, or vitreous earthenware thoroughly glazed. Range closets shall be provided with an automatic dumping tank or may be of the siphon ejection type. The tank shall supply for each single seat not less than two gallons of water at each discharge. The entire volume of water shall be delivered at once at one end, and discharged at the other end of the trough. The discharge from such ranges shall be properly trapped and vented before final disposal to septic tank or public sewer.

(9) URINALS. (a) *Type.* Urinals shall be made of material impervious to moisture and which will not corrode under the action of urine, and be of such design, materials, and construction that they may be properly flushed and kept in a sanitary condition. If cast iron is used in the construction of urinals it must be enameled on the inside and coated with durable paint or be enameled on the outside. No sheet iron urinals will be permitted except in outbuildings such as private or similar enclosures situated where a public or private sewage system is not available. Only individual urinals shall be used in public buildings and places of employment. Such individual urinals shall be of porcelain or vitreous china, set into the floor and the floor graded toward the urinal and shall be equipped with an effective automatic tank or a satisfactory foot-operating flushing device. See H 62.22 (31), H 63.03.

(b) *Flushing.* All stall urinals connected to a sewerage system shall be provided with an effective automatic tank or a satisfactory foot operating flushing device. All automatic flushing devices shall be so adjusted as to cause thorough flushing of the urinal at regular intervals. A battery of not more than four stall urinals may be flushed with one automatic tank, providing the flush pipe is so sized and graded as to insure sufficient pressure, volume, and equal distribution of the tank contents. Existing urinals of the trough or

gutter pattern shall be flushed either by automatic flushing tanks or by an adequate direct water supply through a brass distributing pipe with perforations at 2-inch intervals and extended the full length of the gutter. The backs of gutter stalls to a height of 3½ feet shall be kept constantly moist with a supply of water while the fixture is in use.

H 62.13 Rain water connections. (1) **RAIN WATER DISPOSAL.** Where no storm sewer is accessible, surface inlets and rain water conductors should be drained separately to the curb line where practicable by drain pipes not less than 4 inches in diameter, and discharge into the public gutter, unless permitted to drain elsewhere. See H 62.04 (10) (b).

(2) **INSTALLATION DETAILS.** (a) *Inside leaders.* All roof leaders placed within the walls of any building, in an interior court, ventilating or pipe shaft, shall be installed as specified for soil, waste and vent pipes when connected to a combination sewer or drain. Rain water leaders shall not be used as soil, waste or vent pipes; nor shall any soil, waste or vent pipes be used as rain water leaders. Outside catch basins, garage drains, area drains and subsoil drains installed in compliance with the provisions of this code may be connected to conductors at a point more than 4 feet below grade level.

(b) *Rain water connected to storm sewers.* Rain water leaders within a building connecting to storm sewers shall be treated in the same manner as those entering a combination system, except that pipe used in construction may be cast iron, galvanized, asphaltum coated or black iron pipe.

(c) *Connection to drains.* When rain water leaders are connected to house drains within the building, the horizontal part extending 2 feet inside the basement wall and the vertical portion outside the building wall shall terminate with the hub above grade line, and shall be made of cast iron of same weight and durability as provided for house drains. See H 62.22 (32).

(d) *Roof terminal connections.* Connections between gutters, troughs, roof areas, and rain water leaders inside the building shall be made of durable materials. The term "durable" material as used in this section shall mean a brass ferrule, a brass soldering nipple, light lead pipe, 12 oz. copper, No. 18 gauge brass or cast iron receivers properly connected.

(e) *Defective rain water leaders.* When an existing rain water leader within the walls of any building becomes defective, such leader shall be replaced by one which conforms to the requirements of this code.

(3) **CISTERN OVERFLOW.** Overflow pipe from cisterns shall not connect directly with any house sewer, but shall discharge into an open fixture, catch basin or floor drain. Overflow pipes from cisterns, however, shall not discharge into sanitary sewers.

H 62.14 Special requirements. (1) **TOILET ROOM VENTILATION.** All toilet rooms and bathrooms shall have at least one outside window that may be opened or be provided with local vent pipes or air shafts extending to the outside air. Local vents or air shafts for toilet rooms shall not be connected with the plumbing system, and must be so installed as to provide adequate ventilation. See H 62.15 (14).

(2) **BAR WASTES.** Bar, soda fountain, and similar wastes may be installed in accordance with one of the methods shown in H 62.22 (33). The waste pipe outlet and trap may be located at either side of the fountain or serving counter or at any convenient point at the side thereof. The horizontal local waste pipe shall not exceed 30 feet. Accessible cleanouts shall be provided.

Note: Waste piping may be made of copper or brass with approved fittings and joints; or cast iron or galvanized iron with approved fittings, joints and connections. Unions of the ground joint type or equivalent should be used at such points that the entire piping may be readily taken down for purposes of cleaning.

(3) **REFRIGERATOR WASTES.** The waste pipe from a refrigerator, ice box or trap, or any receptacle in which provisions are stored shall not connect directly with any drain, soil or waste pipes. Such waste pipes shall be so arranged that they may be flushed properly. See H 62.22 (34).

(4) **HYDRAULIC MACHINERY.** Wastes from hydraulic motors, hydraulic elevators, or other machinery discharging large quantities of water, shall be detained in a catch basin or receiving tank of sufficient size, and so connected as to prevent the discharge of the wastes under pressure. See H 62.05 (4), H 62.07 (7) (b).

(5) **DRINKING FOUNTAIN DRAIN.** Waste pipes from drinking fountains may discharge into a trapped funnel or floor drain. Such waste pipes however, must be trapped to preclude their use as a local vent pipe. When drinking fountains are located on four or more floor levels and connect to the same local waste stack, such stack shall be extended separately through the roof. When drinking fountains are connected directly to soil, waste or drain pipes, they shall be trapped and vented properly. For methods of installation see H 62.22 (35).

(6) **DENTAL CUSPIDORS.** Dental cuspidors when connected to a waste pipe must be effectively trapped and vented, as shown in H 62.22 (36). The length of the horizontal waste pipe between the vent pipe and trap must not exceed 15 feet. The total fall of the horizontal waste pipe between trap and vent shall not exceed the inside diameter of said waste pipe.

(7) **CLEAR WATER DRAINS.** The discharge of clear water from beer pumps, water motors, overflow pipes from water supply tanks, expansion tanks, and drip pans shall be provided for in the same manner as for refrigerator wastes. Overflows of this type discharging large amounts of water or which have a constant flow may not under certain conditions discharge directly or indirectly into a private sewage treatment system.

(8) **ACID WASTES.** (a) *Neutralizing basins.* Where it is necessary to dilute or neutralize acid wastes to properly protect the piping of a drainage system, all acid wastes from sinks or other receptacles shall discharge into a catch basin or neutralizing basin of a capacity sufficient to properly dilute or neutralize such wastes.

(b) *Piping.* The waste pipes and traps for acid tanks, sinks and other receptacles receiving the discharge of acids in chemical laboratories, electrotyping, lithographing and other similar establishments must be made of extra heavy acid resisting or acid proof type, extra heavy lead pipe, or lead-lined iron pipe of adequate durability. The waste pipes when serving as a local conveyor between acid tank,

dilution tank or other receiving basin may be of asbestos cement pipe and fittings or of vitrified clay incased in concrete of substantial construction or its equal and provided with a vent pipe to the open air where necessary. See H 62.15 (14).

(9) **BOILER BLOWOFF BASIN.** All exhaust, blowoff, sediment or drip pipe connections from a high pressure steam boiler, shall not be connected to any house sewer or drain, without first being cooled to a temperature below 140° Fahrenheit in a suitable tank, catch basin, or other cooling device. The capacity of the catch basin or other cooling devices shall depend upon the steam pressure carried, the size of the boiler, and method of operation. The capacity of such basin shall be sufficient to hold at least one gauge of the boiler. All cooling devices when receiving the blowoff from such boilers shall be provided with a relief pipe, extended independently to the outer air. The size of the relief pipe shall be equal to the threaded opening provided in the cover of the basin.

(10) **PIPE BENDING PROHIBITED.** Bending of brass, galvanized steel or galvanized wrought iron pipe is prohibited. See section H 63.04.

H 62.15 Materials. (1) **QUALITY.** All material used in any drainage or plumbing system, or part thereof, shall be free from defects that impair service.

(2) **LABELING.** Each length of pipe, fitting, trap, fixture, and device used in a plumbing or drainage system, shall be stamped or indelibly marked with the weight, or quality thereof, and the maker's mark or name.

(3) **SEWER AND DRAIN PIPE.** (a) Asbestos-cement building sewer pipe and fittings shall be fabricated from material consisting of a mixture of portland cement, or portland pozzolana cement, and asbestos fiber, with or without the addition of curing agents. The pipe shall be free from organic substance and shall be formed under pressure, be thoroughly cured and meet the following requirements:

1. The pipe shall show no signs of leaking, weeping, or cracking when tested for general soundness and strength by subjection to an internal hydrostatic pressure of 50 pounds per square inch. The test shall be conducted by placing the pipe in a pressure testing machine with gaskets which seal the ends of the pipe and exert no end pressure. All air shall be expelled from the pipe and the internal water pressure increased at a steady rate to the specified hydrostatic test pressure.

2. Test pipe specimens shall have a crushing strength such that they shall not fail until the total applied load exceeds the tabular values given in the following table for the size of pipe being tested. The specimens shall be tested by the 3-edge bearing method. The two lower bearings shall consist of 2 straight wooden strips with vertical sides, each strip having its interior top corner rounded to a radius of approximately ½ inch. The strips shall be securely fastened to a block with their interior vertical sides parallel and a distance apart of not less than ½ inch nor more than one inch per foot of diameter of pipe. The upper bearing shall be a wooden block, not less than 6 by 6 inches in cross section, straight and true from end to end. The upper and lower bearings shall extend the full length of the specimen. The test load shall be applied in such a way as to leave free movement in a vertical plane passing midway between the lower bearings. The rate of loading shall be 2,000 pounds per minute per lineal foot, with a

tolerance of plus or minus 500 pounds per minute per lineal foot. The breaking load shall be determined. For sewers laid at a depth of 12 feet or more the crushing strength per foot shall be at least 2,400 pounds for 4 inch to 8 inch pipe, 2,800 pounds for 10 inch pipe, and 3,000 pounds for 12 inch pipe.

Size Inches	Flexural Strength 9 Foot Span Pounds	Crushing Strength 3-edge Method Pounds per Foot
4	550	1,740
5	950	1,680
6	1,475	1,420
8		2,500
10		2,200
12		2,200

3. The pipe shall be of uniform structure throughout and such that it may be cut, drilled and tapped.

4. Couplings shall be of the same crushing strength and general soundness as specified for the pipe. The necessary rubber rings shall be furnished with each coupling.

5. Each pipe shall be free from bulges, dents, and tears on the inside surface which result in a variation in diameter greater than 3/16 inch from that obtained on adjacent unaffected portions of the surface.

6. The exterior edge of the ends of the pipe which extend into the coupling area shall be free from axial chips having a length greater than 1/2 inch, a width greater than 1/2 inch, or a depth greater than 1/8 inch. Similarly, the interior edge shall be free from axial chips having a length greater than one inch, a width greater than one inch, or a depth greater than 1/8 inch.

(b) Cast iron pipe and fittings shall be coated pipe conforming to Commercial Standard CS 188-59, United States Department of Commerce, and the following requirements:

1. Weights. Use of service weight pipe shall be limited to buildings 5 stories or less in height. Extra heavy weight pipe shall be used in buildings 6 stories or more in height. Wall thickness of fittings and the hubs shall correspond with that of the pipe of the same size and kind.

2. Bends. When direction of flow changes from horizontal to vertical the radius of bends shall be as follows: (All dimensions are given as inches)

Size of pipe	2	3	4	5	6
Minimum radius	3	3 1/2	4	4 1/2	5

When direction of flow changes from vertical to horizontal or when it is at right angles and changes in the same horizontal plane the radius of bends shall be as follows: (All dimensions are given as inches)

Size of pipe	2	3	4	5	6
Minimum radius	8	8 1/2	9	9 1/2	10

(c) Concrete pipe and fittings shall conform to A.S.T.M. "Standard Specifications for Concrete Sewer Pipe," serial designation C-14-59. Extra strength pipe shall be used for sewers laid at a depth of 12 feet or more. For pipe 27 inches or larger in diameter, the pipe shall conform to serial designation, C-76-60T.

(d) Copper pipe and fittings shall conform to A.S.T.M. "Standard Specifications for Seamless Copper Water Tube" (TYPE L) serial designation B-88-58.

(e) Vitrified clay pipe and fittings shall conform to A.S.T.M. "Standard Specifications for Clay Sewer Pipe," serial designation C-13-57T or C-200-59T, the latter standard to be used for sewers laid at a depth of 12 feet or more.

(4) Cast iron soil and waste pipe stacks and branches shall conform to subsections H 62.15 (3) (b) or H 62.15 (5). Extra heavy pipe shall be used for stacks and branches receiving drainage from more than 5 stories of any building.

(5) Screw thread cast iron I.P.S. pipe and fittings shall conform to A.S.T.M. "Standard Specifications for Cast Iron Pressure Pipe," serial designation A-377-57.

(6) WROUGHT IRON PIPE (GENUINE). All wrought iron pipe shall be galvanized and shall conform to the A.S.T.M. "Standard Specifications for Welded Wrought Iron Pipe," serial designation A-72, latest revision.

(7) MILD STEEL PIPE. All mild steel, welded or seamless, shall be galvanized, and shall conform to the A.S.T.M. "Standard Specifications for Welded and Seamless Steel Pipe," serial designation A-53, latest revision.

(8) SCREW THREAD FITTINGS. Threaded fittings for vents, back vents, soil and waste pipes shall be of cast iron, galvanized malleable iron or brass. Waste fittings shall be of recessed, drainage pattern, and shall be galvanized or asphaltum coated. Drainage fittings shall have a minimum length from face to center as follows:

Pipe size, inches.....	1¼	1½	2	2½	3	4	5	6
Length, inches.....	2¼	2½	3½	3¾	4¼	5½	6½	7½

Note: Long turn Y branches or Y and 1/8 bend are recommended. See H 62.14 (10) and H 62.22 (38).

(9) LEAD MATERIALS. (a) *Waste and vents.* Lead waste and vent pipes shall be the best quality of drawn lead pipe, having a minimum weight per foot as follows:

Inside diameter, inches.....	1¼	1½	2	3	4
Weight per foot, pounds.....	2½	3½	4¾	6	8

(b) *Traps.* All lead traps and bends shall have a minimum wall thickness of one-eighth inch.

(c) *Water supply piping.* Lead water supply piping should have minimum weights shown in the following table:

Inside diameter, inches	Weight lbs. per foot	Wall thickness inches	Classification	
			East	West
¾	2		AA	XS
1	2		AA	XS
1½	3		AA	XS
2	3½	.231	AA	XS
2½	4¾	.246	AA	XS
3	7¾	.320	AAA	XXS
3½	11¼	.386	AAA	XXS
4	19½	.504	AAA	XXS

(d) *Sheet lead.* Sheet lead shall weigh not less than 4 pounds per square foot.

(10) BRASS PIPE AND FITTINGS. (a) *Specifications.* All brass pipe used for soil, waste, vent and water pipes, except fixture traps and overflows, shall be of commercial standard pipe size and conform to A.S.T.M. "Standard Specifications for Brass Pipe," serial number B-43, latest revision.

(b) *Fittings for soil and waste pipes.* Brass screw thread fittings used for soil and waste pipes, shall be of the recessed, drainage fitting pattern.

(c) *Fittings for water pipe.* Fittings and couplings for brass water pipe shall be of unfinished red brass, with flat band, guaranteed for 175 pounds water-working pressure and shall conform to A.S.A. "American Standard Brass or Bronze Screwed Fittings," serial number B-16.15, latest revision. In erecting brass pipe, friction wrenches and friction vises shall be used exclusively except on pipe larger than 3 inches in diameter.

(d) *Brass tubing.* All brass tubing used for fixtures, traps and overflows between wall or floor and fixtures shall be made of seamless brass tube with a thickness of at least 0.0453 inch (No. 17 Brown & Sharp Gauge) and shall conform to A.S.T.M. "Standard Specifications for Seamless Brass Tubes," serial number B-135, latest revision.

(e) *Traps and overflows.* All brass fittings used for fixtures, traps and overflows shall be of a good quality of brass, free from sand holes, flaws or other defects, and of a uniform thickness equal to twice the thickness of the brass tubing. The thickness of the threaded ends shall be equal to the thickness of the fitting at the root of the thread.

(f) *Soldering nipples* shall be of heavy cast brass, or of brass pipe of weight, thickness and size conforming to standard pipe sizes. (SPS). When cast they shall be of full bore and of not less than the weights given in the following table:

Inside diameter	Weight
1½ inch	0 lb. 6 oz.
1½ inch	0 lb. 8 oz.
2 inch	0 lb. 14 oz.
2½ inch	1 lb. 6 oz.
3 inch	2 lb. 6 oz.
4 inch	3 lb. 8 oz.

(g) *Weight of brass ferrules.* Brass ferrules shall be of a good quality of brass, composed of a mixture that will fuse readily with plumbers' solder, free from sand holes, flaws or other defects, uniform in thickness, and at least four and one-half inches long, of a size and weight as shown in the following table:

Inside diameter, inches	Weight
1½	1 lb. 1 oz.
2	1 lb. 4 oz.
3	1 lb. 14 oz.
4	2 lb. 8 oz.
5	3 lb. 0 oz.
6	3 lb. 8 oz.

(11) **COPPER TUBE AND FITTINGS.** (a) *Copper tube* used for water, soil, waste and vent piping shall conform to A.S.T.M. "Standard Specifications for Seamless Copper Water Tube," serial number B-88, latest revision. Copper water tube used for underground water lines shall be type "K," either soft or hard temper. Copper tube used for interior water lines shall have a wall thickness equal to or better than type "L" and shall be hard temper, except that concealed vertical tube may be of soft temper for repair and replacement lines only. Copper tube used for soil, waste and vent piping shall have a wall thickness equal to or better than type "M" and shall be of hard temper.

(b) *Fittings* used with copper water tube shall be of the sleeve type, of such size that the solder will completely fill the joints by capillary action. Cast red brass fittings shall conform to A.S.A. "American Standard Cast-Brass-Solder-Joint Fittings," serial number B-16.18, latest revision. Wrought copper fittings may be used for water piping only and shall have a wall thickness at least equal to that of the tube with which it is to be used. All waste fittings shall be cast red brass recessed drainage fittings and shall be soldered. Sleeve branches (saddle tees) will not be allowed. Fittings on water pipe may be soldered, flared or flanged provided that all above-ground tube which will be concealed shall be soldered. The solder used shall be 50-50 lead-tin (new metals) or tin-antimony containing 90 to 96% tin and 4 to 10% antimony.

(12) **SHEET COPPER OR BRASS.** All sheet copper or brass shall be of sufficient weight to serve the purpose for which it is used. Sheet used for local and interior ventilating pipe shall have a thickness of at least 0.0159 inch (No. 26, B. & S. gauge).

(13) **GALVANIZED SHEET IRON.** Galvanized sheet iron for local room vents shall be not lighter than the following B. & S. gauge:

- No. 26 for 2 to 12 inch pipe.
- No. 24 for 13 to 20 inch pipe.
- No. 22 for 21 to 26 inch pipe.

(14) **ASBESTOS CEMENT PIPE AND FITTINGS.** Asbestos cement pipe and fittings and other equal piping materials with approved fittings and methods of jointing may be used for local vent pipes. See subsections H 62.14 (8) (b), H 63.02.

Note: The addresses of the organizations preparing standards referred to in this section are as follows:
 A.S.A. (American Standards Association), 70 East 45th St., New York 17, N. Y.; A.S.T.M. (American Society for Testing Materials), 1916 Race St., Philadelphia 3, Pa.; A.S.M.E. (American Society of Mechanical Engineers), 29 W. 39th St., New York, N. Y.

History: 1-2-56; am. (3), (4), and (5), Register, August, 1961, No. 68, eff. 9-1-61.

H 62.16 Joints and connections. (1) **SEWER AND DRAIN PIPE JOINTS.** (a) *Vitrified pipe.* Joints in vitrified pipe shall be either hot poured joints, made with acceptable bituminous or plastic materials, or be pre-fabricated resilient materials bonded to the pipe at the producing plant.

1. Hot poured joint. Hot poured joint compounds shall be water resistant and shall meet requirements hereinafter set forth. A primer shall be applied to the inside face of the bell and outside face of the spigot at least 24 hours prior to installation and preferably by the

manufacturer. Joint faces shall be clean. In joining vitrified clay pipe, or fittings, the spigots shall be carefully centered into the bells. Joints shall be firmly packed with uncoiled hemp, oakum or jute in such a manner as not to disturb alignment. The depth of the jointing compound shall be at least 75% of the hub-depth. Care shall be exercised in placing the running rope to insure non-leakage during pouring and it shall not be removed until the compound is set. The compound shall be poured continuously and as rapidly as possible until the joint is completely filled.

a. Joint-sealer compounds shall consist essentially of asphalt, coal-tar pitch or plastic soluble in CS₂ and inert mineral filler. The compounds shall be free from water, uniform in appearance and consistency, and shall not foam when heated to 350° F. Proportions of component materials of the compounds, expressed as percentages of total weight, shall be within the limits of the accompanying table. The physical properties of joint sealing compound also shall be as shown in said table. Material not definitely specified shall be of a good commercial quality entirely suitable for the purpose.

CHEMICAL COMPOSITION AND PHYSICAL PROPERTIES

	Asphalt Base	Coal Tar Pitch Base	Plastic Base
Asphalt (soluble in CS ₂)	45-60		
Coal-tar pitch ¹		75-80	
Plastic ² (soluble in CS ₂)			35-50
Inert mineral matter (determined as ash)	40-55	20-25	50-65
Organic matter (insoluble in CS ₂), maximum	5		5
Specific gravity at 77° F.	1.40-1.55	1.40-1.50	1.65-1.75
Ductility at 77° F. (cm.), minimum	1.5		
Softening point, °F.	190-250	180-190	200-230
Penetration:			
At 77° F., 100 gm., 5 sec.	5-15	0-2	0-1
At 115° F., 50 gm., 5 sec.		5-10	0-3

¹The coal-tar pitch shall be produced from coke-oven tar by distillation or special processing.

²Acyclic polymeric hydrocarbon.

b. No chemical action shall occur when the joint sealer compounds are subjected to immersion for 5 days in each of the following solutions: 1 percent HCL, 1 percent HNO₃, 1 percent H₂SO₄, 5 percent KOH, and saturated H₂S.

c. The content of inert mineral filler, asphalt, plastic, and organic matter in the compound shall be determined in accordance with A.S.T.M. "Standard Method of Test for Bitumen," serial designation D 4-52.

d. The specific gravity of the compound shall be determined in accordance with A.S.T.M. "Standard Method of Test for Specific Gravity of Asphalts and Tar Pitches Sufficiently Solid To Be Handled In Fragments," serial designation D 71-52.

e. Ductility shall be determined in accordance with A.S.T.M. "Standard Method of Test for Ductility of Bituminous Materials," serial designation D 113-44.

f. The softening point of the compound shall be determined in accordance with A.S.T.M. "Standard Method of Test for Softening Point of Bituminous Materials," serial designation D 36-26.

g. The penetration of the compound shall be determined in accordance with A.S.T.M. "Tentative Method of Test for Penetration of Bituminous Materials," serial designation D 5-59T.

h. Joint-sealing compounds shall not fail, either in bond or cohesion, under a bond stress of 75 p.s.i. when tested as follows: Three portland-cement briquets shall be made and cured for 7 days in accordance with A.S.T.M. "Standard Method of Test for Tensile Strength of Hydraulic Cement Mortars," serial designation C 190-59, except that the sand shall be concrete sand conforming to the requirements of A.S.T.M. "Standard Specifications for Concrete Aggregates," serial designation C 33-57. The briquets shall be cut smoothly in two parts transversely at the waist, oven dried at 220° F. for 2 hours and allowed to cool at room temperature for at least 2 hours. The two parts shall be placed in a suitable mold or form and a one-inch-square piece of vitrified clay with all glaze removed shall be placed between and approximately $\frac{3}{8}$ inch from the two parts of the briquet and so that the longitudinal axis will be approximately normal to the one-inch-square surfaces. Sealing compound, heated to a free-flowing temperature but not in excess of the pouring temperature indicated on the container, shall be poured into the mold between the cut surfaces of the briquet and the piece of vitrified clay as indicated in the accompanying figure and allowed to air cool at room temperature for at least 2 hours. If the manufacturer's directions for use of the compound as printed on the container require priming, the cut surfaces of the briquet and the vitrified clay shall be so primed with the recommended primer before pouring the compound. Any bituminous material which may have accumulated on the briquets or pieces of vitrified clay other than on the one-inch-square surfaces shall be removed with a knife.

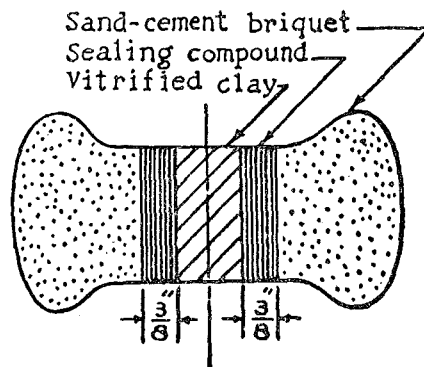

The bearing surfaces of the clips of the testing machine shall be clean and free from incrustations. The roller bearings shall be well oiled and in condition to ensure free turning. The stirrups supporting the clips shall be kept free from accumulations and the pivots shall be in proper adjustment so that the clips may swing freely on the pivots without binding in the stirrups. The test specimens shall be carefully centered in the clips. The load shall be applied continuously at a uniformly increasing rate of 600 ± 25 pounds per minute until the specimen fails in bond or in cohesion.

2. Pre-fabricated joints. Resilient jointing materials shall conform to the A.S.T.M. "Tentative Specifications for Vitrified Clay Pipe Joints Using Materials Having Resilient Properties," serial designa-

tion C-425-60T. Only virgin materials shall be used. The composition of the jointing material shall be periodically checked after fabrication by an accredited laboratory. Prior to making the installation, the joint material on both the bell and spigot ends shall be wiped clean and coated with a lubricant of an adhesive or welding type. The spigot end shall be inserted in the bell and pressure applied until the pipe is properly seated.

(b) *Concrete pipe.* Joints in concrete pipe shall be made with hot poured jointing compounds or rubber gaskets.

1. Hot poured joint. Hot poured joints shall conform to requirements of subsection H 62.16 (1) (a) 1.

2. Rubber gasket joint. Rubber gaskets shall consist of durable and resilient rubber formed into a shape which will be compressed within the annular space between two adjacent pipes to form a watertight joint. The rubber gasket shall conform to A.S.T.M. "Tentative Specifications for Watertight Rubber Type Gasket for Circular Concrete Sewer and Culvert Pipe," serial designation C-443-60T.

(c) *Asbestos-cement pipe.* Asbestos-cement pipe shall be jointed by ring type coupling consisting of a sleeve made of the same material as the pipe, a rubber center ring, and 2 rubber sealing rings. Rubber rings shall be of moulded resilient and durable rubber. The inside diameter of the sleeve shall have end bevelling and inside machining to provide a smooth surface. A groove for the center ring and 2 grooves for the sealing rings shall be machined in the sleeve. The end outside surfaces of the pipe shall be machined at the factory to proper dimensions to permit the pipe to enter the coupling after lubricant is applied to the pipe ends in a manner to cause the sealing rings to compress and slide to provide a proper seal.

(d) *Dissimilar pipe.* Underground joints between dissimilar materials shall be made with suitable adapters approved by the board.

Note: Standards of the American Society for Testing Materials (ASTM) are available for inspection at the office of the board of health, the secretary of state and the revisor of statutes, or may be procured for personal use from the American Society for Testing Materials, 1916 Race Street, Philadelphia 3, Pennsylvania. Commercial Standards of the U. S. Department of Commerce also are available for inspection at the office of the board of health, the secretary of state and the revisor of statutes, or may be procured for personal use from the Superintendent of Documents, U. S. Government Printing Office, Washington 25, D. C.

(3) **CAST IRON PIPE.** All joints in cast iron pipe and fittings shall be made by first inserting a roll of hemp, oakum or jute and thoroughly calking it in place, and then following with pure molten lead well calked, not less than one inch deep, lead to be brought to top of hub and faced. No paint, varnish or putty will be allowed on the joints until they have been tested.

(4) **GALVANIZED WROUGHT IRON AND STEEL PIPE.** Joints in galvanized iron pipe shall be standard screw joints, and all burrs or cuttings shall be removed. All screw joints shall be made with white or red lead, mineral paint, or other approved compounds, applied on outside thread. Not more than three threads of made-up joints shall be exposed, and they shall be protected by a coating of mineral or asphaltum paint or other approved compound, applied before the work is tested or inspected.

(5) **BRASS PIPE.** Joints on brass pipe shall conform to provisions of subsection (4) except that exposed threads require no coating.

(6) **COPPER TUBE.** All joints in copper water tube shall be made in a manner to insure a permanent water-tight joint. The joints shall be properly fluxed and made with approved solder. The joints shall be wiped clean to remove excess flux after the soldering operation has been completed. See subsection H 62.15 (11).

(7) **DISSIMILAR METALS.** Connections between wrought iron or brass and cast iron shall be either a calked joint or a screw thread joint. Connections between lead and cast or wrought iron pipes shall be made with a calked joint, a soldering nipple or threaded joint. Wrought iron pipe connections shall be made with a right and left coupling, flanged union with durable gasket, a ground faced union or a running thread with lock nut made tight with wicking and red or white lead. Joints in lead pipe or between lead, brass or copper pipes shall be wiped joints except solder brazed or sweated joints on reamed, concave brass bushings in connection with exposed brass or lead traps. See subsection H 62.22 (20).

(8) **WASTE PIPE.** (a) *Lead.* All lead under-floor waste pipes so far as practicable should be free from short bends. All branch joints in connection with water-carrying waste pipes should be of the sanitary "Y" pattern and all such joints should be so prepared and joined as to leave a clean interior, free from solder, obstructions or reductions of the respective pipe diameter. All lead waste pipes should be properly graded and substantially supported to guard against sagging or displacement and so installed that stoppages may be removed from any portion. To accomplish this, sink and basin traps should be so joined or connected to the waste pipes that they may be readily removed for wiring or rodding of the pipe throughout its entire length including waste branches thereof. Where lead closet bends are used, no water carrying waste pipe or branch shall be connected thereto. Where solder nipples are used in connecting to iron bends they should be straight bore of a size corresponding with the inside diameter of the waste pipe, but no such nipple should be less than 2 inches inside diameter. All lead bends should be so made as not to weaken the lead at the heel of the bend and all joints shall have a wall thickness of solder not less than three-sixteenths of an inch measured at the center of the pipe joint.

(b) *Screw thread.* All under-floor and concealed threaded waste pipes and fittings should be designed and constructed by the plumber to conform with the following minimum specifications: The waste piping for baths, sinks, basins and other similar fixtures shall be properly graded, free from short or unnecessary offsets, and all fittings shall be of the long radius sanitary pattern. Ends of all piping shall be cut straight and reamed on the inside. The thread should be cut to the required length and depth and so made up that the end of the pipe extends to the recess receiving shoulder of the fitting. Where avoidable no 90 degree universal swing joints or any offset connection should be made. All changes in direction should be made by means of "Y"s or 5%, 11¼, 22½, 30, 45, 60, or 90 degree long radius pattern elbows. All ells and other fittings should be full bore and all such pipes and fittings should have a smooth interior.

(9) **ROOF TERMINALS, FLASHING.** The joint at the roof shall be made water tight by the use of copper, lead, galvanized sheet metal or iron plates or flashings. The flashing shall extend not less than 6 inches

from the pipe. All flashings shall be substantially made and so placed as to insure a permanent tight joint. Roof flashings designed and constructed to provide an air space between the pipe and flashing to prevent freezing of soil and vent pipe terminals are recommended. See subsections H 62.15 (9) (d), (12), H 62.22 (18).

(10) **EARTHENWARE.** The connections between soil pipe and fixtures of earthenware, vitreous china or enameled iron shall be made by means of a brass floor plate, not less than three-sixteenths inch in thickness, soldered or wiped to lead pipe, or an iron floor flange connection calked to iron pipe, or an iron or brass connection calked or screwed to wrought iron or steel pipe, with the fixture floor flange bolted to the floor connection with solid brass closet bolts. Floor joints shall be made air-tight with an asbestos graphite ring, asbestos or rubber gasket, or washer, or metal to earthenware, or metal to metal union. A paste of red or white lead or other equal compound may be used.

(11) **OTHER TYPES.** Any type of joint other than those specified in this code which the board approves may be used.

(12) **PROHIBITED FITTINGS.** Sanitary tees of short radius shall not be used except in connecting horizontal to vertical soil or waste pipes in which the flow is toward the vertical line. The use of one-fourth bends or elbows in soil or waste pipes is governed by H 62.15 (5), (8), H 62.22 (37), and (38). One-fourth bends with side or heel outlets except when they are made with "Y" or sanitary "T" branches, and all double hub fittings, double tees and double sanitary tees when used horizontally are prohibited, except when smaller pipes discharge into a larger pipe. Double hubs and double hub fittings may be used on rain water leader and vent lines. Offsets having less than one-fifth pitch will not be permitted. The use of a drive ferrule is prohibited and the use of combination lead ferrules will be permitted only when the calk joint can be made in the upright position. All waste and vent pipes must enter soil pipe by means of properly inserted fittings. The drilling and tapping of soil, vent and waste pipes and house drains to receive waste and vent pipes of any description is strictly prohibited, and in no case will the use of saddles or bands be permitted. No double hub or inverted calk joint shall be permitted in soil and waste lines. Whenever wrought or galvanized iron pipe connects with cast iron, soil waste or vent lines, tapped fittings or tap extension pieces shall be used except where pipe and hub are the same diameter.

History: 1-2-56; r. and recr. (1) and (2), Register, August, 1961, No. 68, eff. 9-1-61.

H 62.17 Repairs and reconstruction. (1) DEFECTIVE PLUMBING. Whenever it shall appear upon inspection that any part of an existing plumbing system is defective, or fails to conform to the requirements of this code and by reason of such failure tends to create a nuisance, it shall be repaired, renovated, replaced or removed within 30 days, upon written notice from the state or local health officer.

(2) **FIXTURES REPLACED.** When an old or defective fixture is removed, to be replaced by a new one, and no other fixture or piping is to be added or remodeled, it will not be necessary to reconstruct the soil, waste or vent piping to make it conform to this code, unless

the same is in a defective condition. In such cases, if found necessary, the fixtures shall be provided with efficient deep seal traps or deep seal resealing traps of the self-scouring centrifugal type.

(3) RECONSTRUCTION. When old or defective plumbing is to be remodeled, additional fixtures installed or the whole plumbing system moved to another part of the building the remodeled system shall be made to conform to this code.

(4) OLD MATERIALS RE-USED. All fixtures, soil, waste, and vent pipes removed from an old building, if found to be in good condition, may be used in the same building or may be used in another building, provided they are approved by the board or local plumbing inspector and the owner of the building in which they are installed gives his written consent.

(5) OLD HOUSE DRAINS. Old house drains may be used in connection with new buildings or new plumbing only when they are found on examination or test to conform to the requirements of this code governing new sewers and drains. If the old work is found defective, the local or state inspector shall notify the owner of the changes necessary to make it conform to the requirements of this code.

(6) REPAIRS. All repairs to fixtures or piping shall be done in a substantial, sanitary and workmanlike manner.

H 62.18 Water supply systems. (1) WATER SERVICE. (a) *Size*. The water service pipe to any building shall be of sufficient size to permit a continuous ample flow of water under maximum simultaneous use to all fixtures and points of service. The minimum diameter of the service pipe shall be five-eighths inch.

(b) *Materials*. The service pipe from a main or from the pump of a privately owned supply to any building shall be copper water tube, lead, brass, cast iron or galvanized steel or wrought iron pipe.

(c) *Valve controls*. Service controls shall include a valve or shut-off at the main, a curb stop or valve at the curb or privately owned pump, and a valve or stop inside the foundation wall of each building.

(2) BUILDING DISTRIBUTION SYSTEM. (a) *Size*. The water supply piping shall be three-fourths inch in diameter for iron or brass pipe. The diameter of any riser or branch serving more than one plumbing fixture or appliance shall not be less than three-fourths inch for iron or brass pipe. The diameters of branches to single fixtures shall not be less than one-half inch except that three-eighths inch pipe not to exceed 5 feet in length may be used to supply water closet tanks, lavatories or similar fixtures. If copper water tube is used the minimum pipe diameters given above may be decreased one standard copper water tube size, except the minimum pipe diameter shall be three-eighths inch.

(b) *Materials*. All water supply pipes within a building shall be of lead, galvanized wrought iron or steel, brass, or cast iron, with brass or galvanized malleable iron fittings, or copper water tube and fittings. No pipe or fittings that have been used for other purposes shall be used for distributing water for drinking or domestic supply purposes. See section H 62.16.

(c) *Supports*. All piping shall be supported to prevent undue strains upon connections or fixtures, and shall be so aligned and

graded that the entire system or parts thereof can be controlled and drained. The formation of traps or sags in water piping shall be avoided where possible. When unavoidable such sags, traps or inverts shall have provisions for properly draining same.

(d) *Valve controls.* Controls within a building shall include a valve or compression stop for each lawn sprinkler, hot water tank, water closet, urinal and point of entrance of the water service. In a multiple dwelling or public building a valve shall also be provided at the base of each riser and for each dwelling unit or public toilet room unless served by an independent riser, and for each branch serving fixtures in the basement.

(e) *Water supply to fixtures.* All plumbing fixtures shall be provided with a sufficient supply of water for flushing to keep them in a sanitary condition. Every water closet shall be flushed by means of an approved tank or flush valve, of at least 4-gallon flushing capacity and at least one gallon for each urinal. The water from flush tanks shall be used for no other purpose than to reseal drain traps. See subsections H 62.12 (8), (9).

(f) *Air chambers.* Each water supply riser and fixture branch shall terminate with an air chamber, the diameter of which shall be not less than the riser or branch it serves, and where possible it shall have a length not less than 24 times the diameter of such riser or branch. In general, air chambers or approved shock absorbers shall be so located and of sufficient size to prevent undue water hammer.

(g) *Relief valves.* Relief valves shall be provided on all domestic hot water boilers or storage tanks of the closed type. No valve of any type shall be placed between the relief valve and a hot water boiler. The relief valve shall be installed at or within 18 inches of a boiler or hot water tank. The discharge pipe from the relief valve shall terminate in an open fixture or not more than 10 inches from the floor as close as possible to a drain properly connected to the house drain or house sewer. No thread shall be permitted at the end of such discharge pipe. The valve shall be an effective relief valve with non-corrosive seat and be of the diaphragm or bellows type which has been certified by a recognized testing laboratory or approved by the board. Relief valves should be provided on all private water systems using displacement type pumping equipment.

(h) *Protection against frost.* All water pipe, storage tanks and flushing tanks subject to low temperatures shall be effectively protected against freezing.

(3) SPECIAL EQUIPMENT. (a) *Separate piping for each source.* A water supply that meets accepted standards of purity for human consumption shall be distributed through a piping system entirely independent of any piping system conveying another water supply.

(b) *Piping by plumber.* In municipalities having public water supply and sewerage systems or in any area platted under ch. 236 adjacent to such municipalities and in metropolitan sewerage districts, no person not licensed by the board as a master plumber or as a journeyman plumber shall install any piping for water supply to any system designed for steam power, heating, temperature regulation, automatic fire protection, hydraulic power, or for any special water usage for industrial or manufacturing purposes. All such

pipng for supplying water for any system for steam power, heating, temperature regulations, automatic fire protection, hydraulic power, or for any special water usage for industrial or manufacturing purposes, shall be installed by the licensed plumber to the appliance forming the unit or initial point of such system and shall terminate with a valve, located at the unit or appliance to be connected.

(c) *Piping by equipment installer.* The connection of appliances forming the initial unit of such systems, to the water supply pipe installed by the licensed plumber, as prescribed by rules and regulations, may be made by the person installing such aforesaid systems, but the connection of the water supply shall be made in a manner to prevent the possibility of contamination of the water supply by the backflow of water from such systems by siphonage, drainage, or force.

(4) PRIVATE SYSTEMS. (a) *Source.* All private water supplies shall be uncontaminated and the source shall conform in construction with the specifications of the Wisconsin well construction and pump installation code. All supplies known to be subject to occasional pollution shall be either discontinued or made safe as directed by the board.

(b) *Capacity.* All private water supply systems, pumps, and water pressure storage tanks serving residences or public school and similar buildings shall be of sufficient capacity and size, and shall have sufficient pressure and volume of water to provide adequate flushing facilities in order to maintain the plumbing fixtures and appliances in a sanitary and good operating condition at all times.

Note: For detailed information and specific rules and regulations governing the location, construction of wells, setting of pumps, sealing of well top, see the Wisconsin well construction and pump installation code adopted by the board pursuant to ch. 162, Wis. Stats.

H 62.19 Back siphonage and cross connections. (1) PROHIBITED FIXTURE INSTALLATIONS. No closet bowl or other fixture equipped with a flushometer valve shall be installed with a side or rear spud located below the lower part of the flush rim of the bowl.

(2) PROHIBITED COMBINATION FAUCET USE. No faucet or combination faucet or like appliance so installed as to form a cross connection directly or indirectly between a safe drinking water and an unsafe or questionable water supply shall be permitted.

(3) PROHIBITED WATER—DRAINAGE SYSTEM INTERCONNECTION. No direct plumbing fixture or pipe connection shall be made between any part of the water supply system and any part of the plumbing drainage system or impure water supply system unless adequately protected against back-siphonage.

(4) PROTECTION FROM BACK-SIPHONAGE. (a) *Fixture inlets.* All fixture water supply inlets of every description shall be located and designed so as to prevent the possibility of back-siphonage or back-drainage of any of the fixture contents into the water supply lines.

(b) *Inlet elevation.* Whenever possible the water supply inlet shall terminate at least two pipe diameters but not less than one inch above the maximum possible water level of the fixture, tank or vat so as to prevent the possibility of back-siphonage.

(c) *Vacuum-breaker.* If the water supply inlet cannot be raised above the maximum possible water level, an approved type of vacuum-breaker shall be installed between the control valve and the fixture in such manner that no back-siphonage is possible under any degree of vacuum in the water lines and with water in the fixture at the maximum possible water level. For positive protection each such fixture shall have a vacuum-breaker installed 4 inches above the maximum water level.

(d) *Maximum water level.* The maximum possible water level referred to heretofore shall be construed as the height to which water can rise in a fixture, tank or vat before it flows freely into the open atmosphere above the fixture rim or through adequate size openings so designed as not to be obstructed by debris or waste matter.

(e) *Impure liquids.* Fixture contents against which back-siphonage protection shall be maintained include all polluttional material, sewage, waste water, processing liquids, chemicals, and all water and other liquids which can be polluted at some time or other.

(5) SPECIAL EQUIPMENT PROTECTION. All water supply equipment and appliances serving special fixtures shall conform with the intent and purposes of this section. Any unusual use for water, as for air-conditioning equipment, hydraulic elevators, presses, fountains, etc., shall be given special consideration in relation to possible pollution of the pure water supply system.

(6) IMPROPER LOCATION OF SEWERS AND DRAINS. Sewers and drains shall never pass directly over water tanks or any place where drinking water, ice, or food is prepared, handled, or stored.

(7) DUAL WATER SUPPLIES. The maintenance of a pressure system of water supply whose purity is questionable, such as cistern water, in the same building in which a pure water supply exists is discouraged, especially if the water is piped throughout the building and not confined to a certain section for special uses or processing. The piping containing such impure water supply shall be painted red and properly labeled at intervals. Under no circumstances shall the two supplies be cross-connected or provision made for their cross-connection. No cross-connection shall be made between piping connected to a public water supply system and piping of a private water supply system. See H 62.22 (40).

H 62.20 Sewage treatment and disposal systems. (1) **SEWAGE TREATMENT TANKS.** (a) *Allowable use.* Septic or other sewage treatment tanks may be constructed where no public sewerage system is available or likely to become available within a reasonable time.

(b) *Permission to construct.* In cities, villages, towns and town sanitary districts permission to construct sewage treatment systems shall be obtained from the local plumbing inspector, where available, local health officer, or health committee. Such permission should be in addition to any approval by the board.

(c) *Location.* No sewage tank shall be located within 2 feet of any lot line, 10 feet of any cistern or 25 feet from any well or other source of water supply used for domestic purposes. Where practicable greater distances should be provided.

(d) *Materials.* 1. Septic tanks shall be water-tight below the cover and be built so as to constitute a separate structure. They shall be

made of a welded metal or monolithic concrete. Metal tanks shall be made of new, hot rolled commercial quality steel or equally suitable metal. The gauge of the metal for the septic tanks shall be as follows:

<i>Septic Tank Capacity</i>	<i>Tank Component</i>	<i>Gauge of Metal</i>
500- 800 gallons	Bottom and side walls -----	14
	Cover -----	12
	Baffles -----	12
1,000-1,800 gallons	Complete Tank -----	10
2,000 or more gallons	Complete Tank -----	7

Steel tanks, including cover with rim, inlet and outlet collars and man-hole extension collars shall be constructed with welded joints in such manner as to provide structural stability and water-tightness. Steel tanks shall be coated, inside and outside, in compliance with U. S. Department of Commerce Commercial Standard 177. Any damage to the bituminous coating shall be repaired by recoating prior to installation of the tank. Steel tanks shall have affixed permanently thereto the seal of the Underwriters Laboratories, Inc. of Chicago, Illinois. 2. Precast concrete tanks shall have a minimum wall thickness of 2 inches. The concrete shall be of such mix as to withstand a compressive load of at least 3,000 pounds per square inch. 3. Each tank shall be clearly marked to show capacity, name and address or registered trade mark of the manufacturer.

(e) *Capacity and design.* 1. The size of a septic tank shall be based on the number of persons using the building to be served or upon the nature of use and type of waste. The minimum liquid capacity of a septic tank measured below the outlet shall be 500 gallons for any installation. The liquid depth shall not be less than 3 feet nor more than 6 feet. The total depth of tank shall be at least 8 inches greater than the liquid depth. For each additional person over six to be accommodated in the described buildings, the liquid capacity shall be increased as indicated in the following table:

Apartment buildings -----	60 gal.
Bars, and cocktail lounges -----	3 "
Bowling alley (per alley rather than per person) -----	125 "
Bowling alley with bar (per alley rather than per person) -----	225 "
Camps--summer use only -----	15 "
Drive-in theaters (per car space) -----	50 "
Factories and offices, exclusive of industrial wastes -----	15 "
Hotels and motels (5 or more rooms) (per bed space) -----	50 "
Mobile home parks -----	30 "
Picnic parks--toilet wastes -----	5 "
Picnic parks with showers and toilets -----	10 "
Restaurant--kitchen and toilet wastes -----	10 "
Restaurant--kitchen wastes only -----	3 "
Retail stores -----	5 "
Rooming houses or boarding house (per bed space) -----	50 "
(non-transient establishments providing rooms, with or without meals)	
Rooming houses, tourist (per bed space) -----	50 "
(4 or less rooms, cabins or cottages)	
Self service laundries--toilet wastes only -----	40 "
Service stations -----	5 "
Single family dwelling -----	75 "
Swimming pool bath houses -----	10 "

Note: The foregoing figures exclude bar, industrial and other wastes unless specifically mentioned.

For schools and other part time use buildings where more than 20 persons are to be served, the capacity of the tank shall be increased above the minimum size by the quantities per additional person indicated in the following table:

Churches and part time assembly halls	7.5 gal.
Schools	15 "
Schools with meals served	20 "
Schools with meals served and showers provided	25 "

Where a food waste grinder, automatic clothes washer, or a dish washer, singly or in combination, are connected to the plumbing system, the septic tank shall be increased in size at least 50 per cent over that size required on basis of population served. Where large volumes of wastes, other than sewage, are tributary to the tank the capacity shall be increased to provide a two day holding period. Under such conditions approval of the design of the sewerage system shall be obtained from the board. See subsections H 62.22 (41), (42), (43).

2. Rectangular tanks shall have a minimum width of 30 inches and shall be constructed with the longest dimensions parallel to the direction of flow. All single compartment cylindrical tanks shall have an inside diameter of not less than 48 inches. When increased capacity is to be provided by using a number of prefabricated tanks the minimum capacity of any unit shall be 500 gallons. When more than two tanks are installed in series approval of the board shall be obtained.

3. a. The inlet and outlet on all tanks or tank compartments shall be provided with open-end cast iron sanitary tees or baffles made of approved materials, so constructed as to distribute flow and retain scum in tank or compartments. The tees or baffles shall extend at least 6 inches above and 9 inches below the liquid level. The inlet and outlet arrangements shall provide for free flow of air between inlet and outlet. At least 2 inches of clear space shall be provided over the top of baffles or tees. The bottom of the outlet pipe shall be at least 2 inches lower than the bottom of the inlet pipe. b. The inlet and outlet pipes between a septic tank and firm ground beyond the excavation made to install the tank shall be cast iron pipe or other pipe approved by the board for this specific purpose. The joint between the pipe and tank shall be made water-tight. A sand bedding, three inches thick, and sand backfill of the excavation shall be provided for steel tank installations. The sand may be pit run material of such size that 100% will pass through a one-inch screen. The bedding for such tanks and backfill around all tanks shall be tamped into place, care being taken to prevent damage to the coating. c. The inlet and outlet openings of all tanks shall contain a "boss," stop or other provision which will prevent the insertion of the sewer piping beyond the inside tank wall facing. d. All connections made between the sewer piping and the tank openings shall be made to conform to sections H 62.15 and H 62.16.

4. a. Each single compartment tank and each unit of a multicompartment tank shall be manufactured or provided with at least one manhole opening at least 20 inches square or 20 inches in diameter. Manholes shall be extended to within at least 12 inches of the ground surface and be provided with substantial concrete, steel, stone or cast iron covers. On steel tanks the collar for manhole extensions shall be at least 2 inches high. b. An inspection opening shall be provided over the inlet baffle of all septic tanks which may be either a manhole or a pipe at least 4 inches in diameter. The upper end of the inspection pipe

or manhole shall terminate not more than 6 inches below the ground surface.

5. The design of all prefabricated septic tanks shall be approved by the board.

6. The discharge of surface, rain, and other large volumes of clear water into a treatment tank is prohibited.

(f) *Maintenance and sludge disposal.* Septic tanks shall be cleaned whenever the sludge and scum occupies one-third of the tank volume. Sludge and scum from septic tanks and any other material removed from a sewage disposal unit, all hereafter referred to as sludge, shall be disposed of in such manner as not to create a nuisance or menace to public health. Unless otherwise authorized by a local health officer the sludge shall be disposed of as follows:

1. By discharge into a public sewerage system when practical. The point and method of discharge into the system shall be subject to the requirements of the municipality.

2. By discharge at a disposal site designated by a city, village, or town for such purpose, or

3. In the absence of a public sewerage system or designated disposal site by one of the following methods:

a. By burial under 18 inches of earth on the premises on which produced at a distance of at least 50 feet from a well or if on other premises at a distance of at least 500 feet from a place of habitation provided that there is also at least 18 inches of soil between the buried sludge and the ground water level or limestone rock.

b. By spreading on land, not used for pasturing livestock or for growing vegetables, at a distance of 1000 feet from a place of habitation.

4. The sludge shall not be disposed of by discharge into a lake, stream, ditch or dry run or be deposited within 25 feet of such watercourses.

(2) **EFFLUENT DISPOSAL.** (a) *Location and method.* The effluent from septic tanks shall be disposed of by soil absorption in a seepage pit, drainage field or by some other manner approved by the board provided such disposal does not create a nuisance or hazard to health. All soil absorption disposal units should be located at a point lower than the grade of any nearby water well and unless permission is obtained from the board shall be located not less than 25 feet from any dwelling or cistern and not less than 50 feet from any water well constructed in accordance with the specifications of the Wisconsin Well Construction and Pump Installation Code. Where water wells do not conform greater distances shall be maintained. No part of a seepage pit or drainage field shall be located within 5 feet of any lot line or within 25 feet of any lake, stream or other water course unless permission is obtained from the board. The type of soil absorption system to be used for effluent disposal shall be determined through percolation tests made in accordance with section H 65.06 (4), Wisconsin Administrative Code.

(b) *Seepage pits.* 1. Seepage pits preferably should be used when deeper soil formations are more porous than the upper soil. The seepage pit shall consist of a chamber walled up with material which allows water to percolate through it, such as dry rubble, brick or

concrete blocks. The bottom shall be left open to the soil. The seepage pit shall not be less than 5 feet in diameter and should have a depth, where practicable, of 6 feet or more below the inlet pipe, depending on the character of the soil. Seepage pits shall not extend into creviced rock formations. Each seepage pit shall be provided with a manhole and a fresh air inlet. The manhole shall be at least 20 inches square or 20 inches in diameter extending to within at least 12 inches of the surface of the ground and be provided with a substantial concrete, stone or cast iron cover. See section H 62.22 (41).

2. The absorption area in a seepage pit per bedroom shall be at least 75% of the area designated in subsection (c) (2). Effective area shall be construed as the bottom area plus the area at the outside wall of the curbing of the pit. The actual thickness of absorptive material below the inlet subjected to the percolation test, but not more than 5 feet, shall be used in calculating wall area. Seepage pits shall be located 10 feet or more apart and as far from wells as the premises will permit. See section H 62.20 (2) (a).

(c) *Drainage tile and siphon.* 1. Drainage tile should be used in place of a seepage pit wherever possible, particularly when the deeper soil tends to be non-porous. In tight soils the percolating tile lines should be surrounded with coarse gravel, crushed rock, or cinders, having a depth below the tile of at least 12 inches. The tile should be laid 12 to 36 inches below the surface and in straight or curved parallel lines separated by 10 feet or more. The tile should be laid on a slope of about 2 inches per 100 feet. Tile should be spaced about one-fourth inch apart and be blinded at the tops with tar paper or broken tile unless surrounded with coarse material in which case the surface of the material should be covered with tar paper or equal. See section H 62.22 (44), (45).

2. The absorption area required for a tile field serving residential property shall be determined from the following table using soil percolation test data:

Percolation Rate Minutes Required For Water to Fall One Inch	Minimum Absorption Area in Square Feet Per Bedroom			
	Normal Plumbing Fixtures	With Garbage Grinder	With Automatic Washer	With*Both Grinder and Automatic Washer
2	50	65	75	85
3	60	75	85	100
4	70	85	95	115
5	75	90	105	125
10	100	120	135	165
15	115	140	160	190
30	150	180	205	250
45	180	215	245	300
60	200	240	275	330
90	240	290	325	400

a. In the case of schools or other part-time-use establishments, one-sixth of the area requirements per bedroom for normal plumbing fixtures shall be provided for each person. In the case of commercial or industrial establishments one-fiftieth of the area requirements for normal plumbing fixtures shall be provided for each gallon per day of sewage or wastes contributed to the disposal system.

b. Where the percolation rate is so slow that more than 60 minutes are required for the water to fall one inch, studies should be made of the possibility of using seepage pits alone or in conjunction with a tile absorption field.

3. Discharge of septic tank effluent into the soil absorption system should preferably be regulated by an automatic siphon. The dosing tank in which the siphon is situated should have a capacity equal to the combined volume of the tile in the absorption system.

Note: Each foot of 3-inch drain tile has a capacity of .367 gallons; 4-inch tile, .652 gallons; 5-inch tile, 1.02 gallons; 6-inch tile, 1.46 gallons; 7-inch tile, 2.012 gallons; 8-inch tile, 2.599 gallons; 10-inch tile, 4.0195 gallons; 12-inch tile, 5.875 gallons. The amount of tile required is governed by the lay of the land and character of the soil. This is important and must receive careful attention. The drainage tile should be laid at a depth of one foot or more below the surface of the ground, and in cases where it is necessary to lay the tile deeper than two feet, an adequate system of ventilation should be provided.

(3) **VENTILATION.** Fresh air inlets shall be provided on all soil absorption systems and be placed so as to assure a free flow of air throughout the entire installation. The vent pipes shall be at least 2 inches in diameter and extend at least 12 inches above the ground surface with a return bend fitting. Fresh air inlets shall be located at least 20 feet from any window, door or air intake of any building used for human habitation. See H 62.22 (41), (45).

Note: Free circulation of air as provided for in this section means air entering through one or more fresh air inlets, passing on through the units and piping in connection therewith, thence through the inverts of the septic tank by means of the vent openings, and the air continuing onward through the house drain, soil, waste and vent pipes to a point above the building, thus not only creating an effective circulation of air but conveying all offensive odors and gases to a point above the roof.

(4) **CESSPOOLS PROHIBITED.** Seepage pits for disposal of untreated sewage are prohibited.

(5) **SEWER CONNECTION.** Private systems for sewage disposal must be discontinued when public sewers become available. The house sewer shall be disconnected from the old system and be reconnected with the public sewer. All abandoned septic tanks and seepage pits shall be immediately filled.

(6) **INDUSTRIAL WASTES.** Treatment and disposal systems for industrial wastes shall be designed to meet the individual needs and be of a type that will adequately purify the specific waste. Owners of industrial establishments producing trade wastes of a toxic, putrescible, or otherwise objectionable character should consult with the board in reference to their problems.

Note: Commercial Standard 177 of the U. S. Department of Commerce is available for inspection at the office of the board of health, the secretary of state and the revisor of statutes, or may be procured for personal use from the Superintendent of Documents, U. S. Government Printing Office, Washington 25, D. C.

History: 1-2-56; am. (1) (f), Register, June, 1956, No. 6, eff. 7-1-56; am. (2) (a), (2) (b), (2) (c) 2, Register, February, 1957, No. 14, eff. 3-1-57; am. (1) (b), (d) and (e), Register, April, 1962, No. 76, eff. 10-1-62.

H 62.21 Inspection and tests. (1) STATE APPROVED INSTALLATIONS. Plumbing installations in newly annexed territory complying with the requirements of the state code shall be approved by the local governing body of the municipality of which such territory becomes a part, and the owner of the property shall be granted permission to connect to the public water supply and sewerage system upon the payment of permit fees where such fees are required.

(2) LOCAL INSPECTION. (a) *Testing.* All piping of a drainage or plumbing system in cities and villages having local plumbing supervisors, except in case of repairs as specified in H 62.21 (6), shall be tested by the plumber in charge, in the manner herein provided, in the presence of the local supervisor of plumbing or his authorized deputies. The material and labor for tests shall be furnished by the plumber in charge.

(b) *Notice for inspection.* The plumber in charge or the owner of the property in case no plumber is employed, shall notify the supervisor in person, by telephone or in writing when the work is ready for inspection. If the inspection is not made within a reasonable time after the notice is given, the plumber in charge, or the owner, may proceed with the work.

(c) *Preparations for inspection.* When work is ready for inspection the plumber in charge, or in case none is employed, the owner, shall make such arrangements as will enable the supervisor to reach all parts of the building readily, shall have present the proper apparatus and appliances for making the tests, and shall furnish such assistance as may be necessary in making proper inspection.

(d) *House drain tests.* The entire house drain with all its branches, receptacles and connections shall be brought so far as practicable to the surface or grade of basement floor and tested with water or air. Upon being found free from defects and leaking joints, the test shall be considered satisfactory.

(e) *Stable and garage tests.* If a stable, garage or any part thereof is used for human habitation, or is so constructed that it may be used as such, the same tests shall be made as for an ordinary dwelling.

(f) *Rain leader tests.* Rain water leaders and their roof connections where they are permitted within the walls of any building, and such branches as connect with the house drain 3 feet beyond basement wall shall be tested with water or air.

(g) *Soil, waste, and vent tests.* Soil, waste and vent pipes, rain water leaders and all work known as "roughing in and underfloor work" between the house drain connections to points above the finished floor and beyond the finished face of walls and partitions shall be tested.

(h) *Water and air test.* The water test shall be applied by closing all openings in the pipes with proper testing plugs, to the highest opening above the roof, and completely filling the system with water, or an air test with pressure of at least 5 pounds shall be used. If the pipes are found free from defects and leaking joints, the test shall be considered complete and satisfactory. Buildings five stories or more in height may be tested in sections as directed by the plumbing supervisor.

(i) *Smoke test.* The smoke test shall be used in testing the sanitary condition of the drainage or plumbing system of all buildings where there is reason to believe it has become dangerous or defective. The smoke machine shall be connected to any suitable opening or outlet in the system. When the system is filled completely with dense pungent smoke, all openings emitting smoke, the openings shall be closed and an air pressure equivalent to a one-inch water column applied for a period of at least 10 minutes. If there is no leakage or forcing of

trap seals, the systems shall be considered air and gas tight. Nothing, however, in this section shall be construed to prohibit the removal of any clean-out or the unsealing of a trap to ascertain if the smoke has reached all parts of the system.

(3) **COVERING OF WORK.** No part of any plumbing or drainage system shall be covered until it has been inspected, tested and approved. If any part is covered before being tested and approved, it shall be uncovered at the direction of the supervisor.

(4) **FINAL INSPECTION.** When the plumbing or drainage system is completed and fixtures are installed the final inspection shall be made.

(5) **INSPECTION FOR CHANGES OR ALTERATIONS.** When additional fixtures are installed or the style or location of any fixture is changed or when changes are made in the piping system, the work shall be inspected.

(6) **TESTS FOR REPAIRS.** Inspections may be made, but tests shall not be required after the repairing or replacing of any old fixture, faucet or valve by a new one to be used for the same purpose, forcing out stoppage, repairing leaks or relieving frozen pipes and fittings. Such repairs or alterations may not be construed to include cases where new vertical or horizontal lines of soil, waste, vent, or interior rain water leaders are used or their relative locations changed. In a building condemned by the proper authorities because of insanitary conditions of house drainage or plumbing, such repairs or alterations as are necessary to make the plumbing sanitary shall be made to conform to the provisions of this code. Tests and inspections of such alterations shall be made as for new buildings.

Note: No test nor inspection shall be required where a house drainage and plumbing system or part thereof is set up for exhibition purposes; nor shall a test be required (although inspection may be made) where the plumbing is placed in an out-house, stable or detached building used exclusively for such purpose.

(7) **DEFECTS IN MATERIALS.** If tests or inspection discloses defective material, leakage, or unworkmanlike construction, which does not conform to the requirements of this code, and which is condemned by the supervisor of plumbing the same shall be removed and replaced within three days, and when necessary retested. The presence of any foreign substance, other than that provided for in this code, about a joint or any part of a plumbing or drainage system shall be sufficient cause for condemning such joint or part of the system. Any split fittings, hubs or defective material which do not conform to the requirements of this code, and which have been condemned by the supervisor, shall be removed from the work and not used again.

Note: Poor workmanship design or methods of installation likewise shall be sufficient cause for the condemnation of the whole or any part of the system.

H 62.22 Sketches. The following charts and sketches illustrating methods of making plumbing and drainage installations shall be followed wherever applicable.

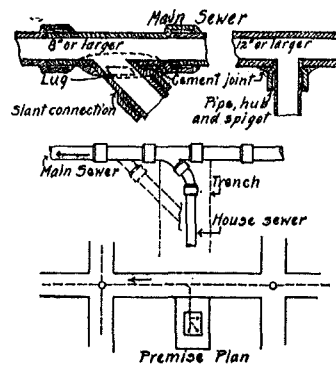

(2) Illustrating method of connecting house sewer to main sewer. H 62.04 (7).

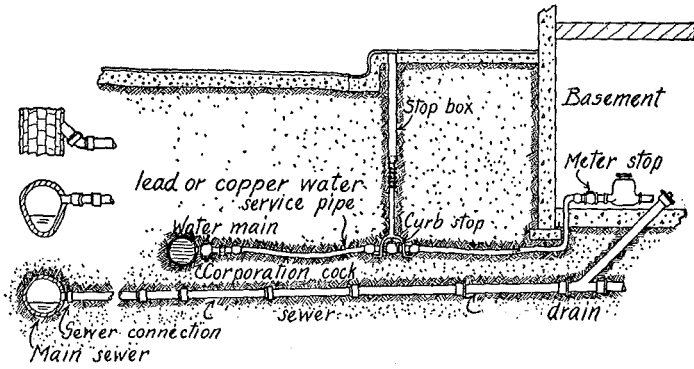

(3) Typical installation of house drain to point within building. H 62.05.

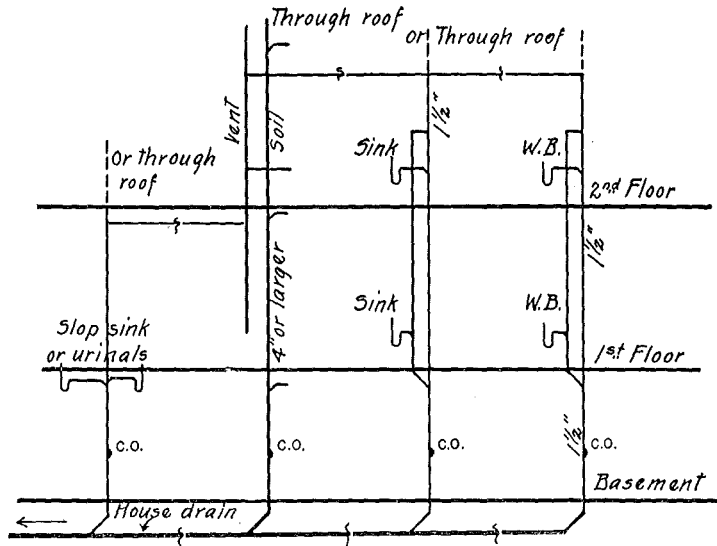

(4) Illustrating permissible waste stacks and vent connections. H 62.06 (1).

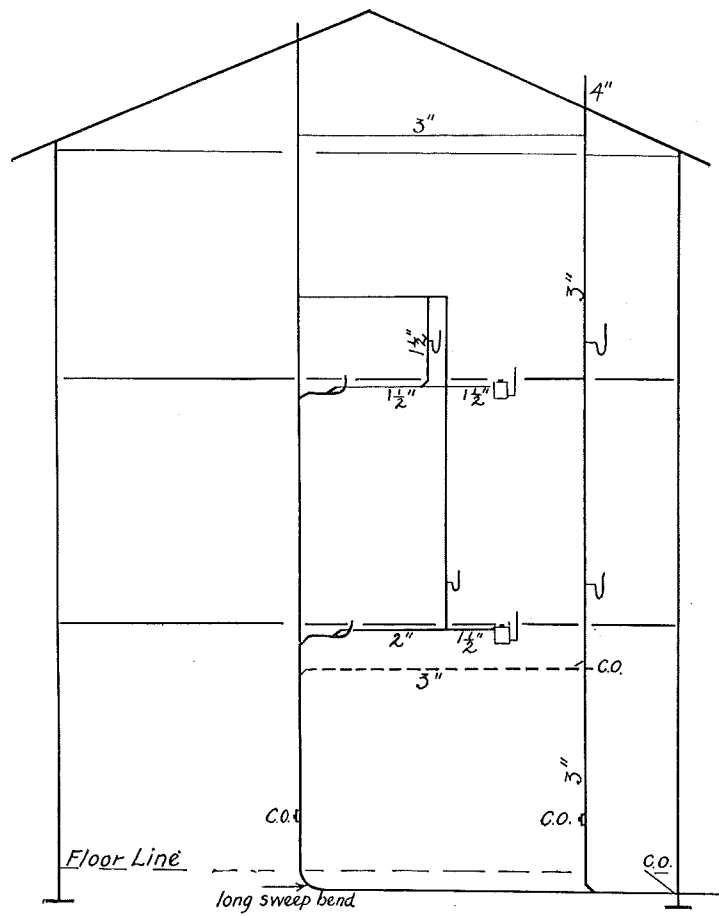

(5) Illustrating permissible method of bathroom and sink waste and vent installation, H 62.06 (1), H 62.07 (8).

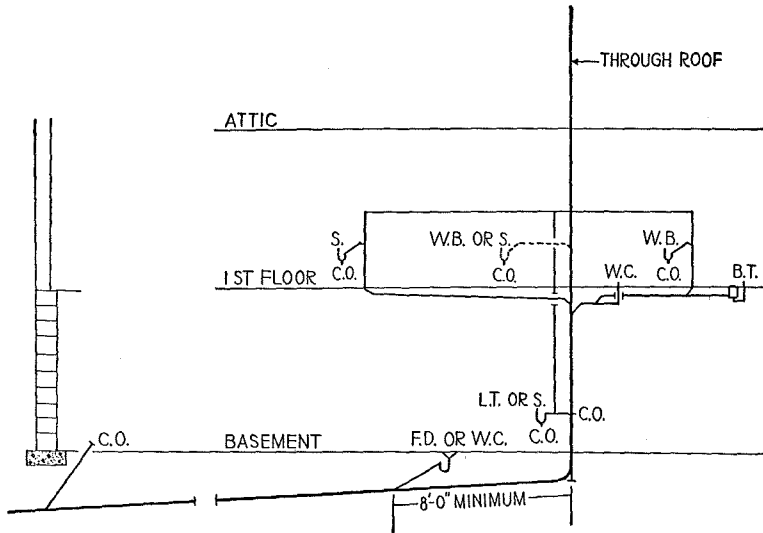

(6) Illustrating minimum requirements for typical one-story building installation. H 62.06 (1), H 62.07 (6), (7) (b).

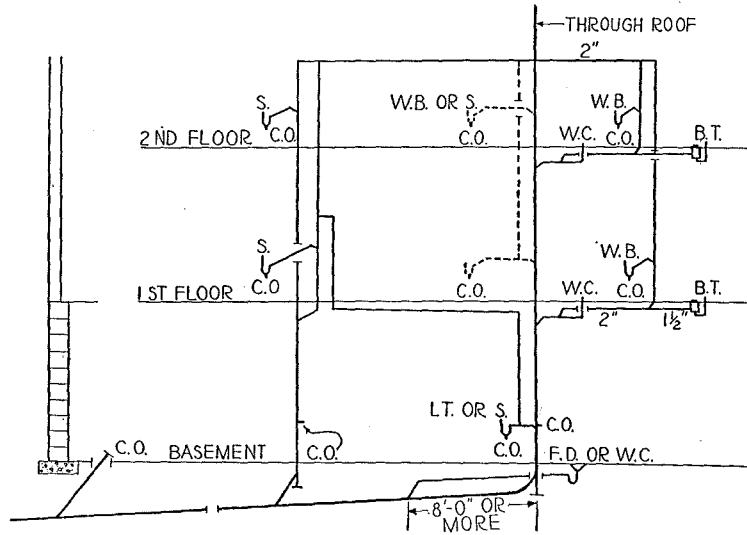

(7) Illustrating minimum requirements for a two-story residence or similar installation. H 62.06 (1), H 62.07 (6), (7) (b).

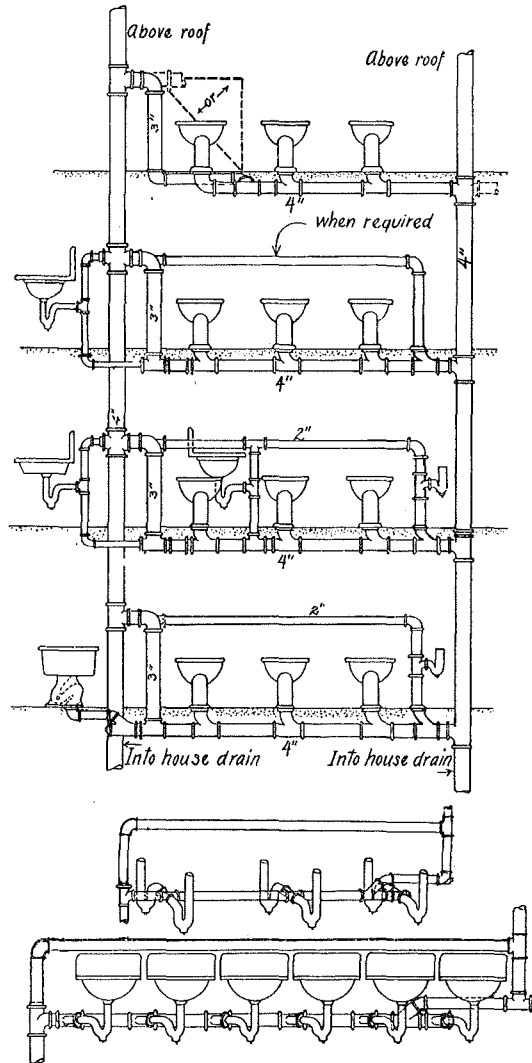

(11) Illustrating method of circuit or continuous venting. H 62.03 (1), (3); H 62.06 (5); H 62.07 (1), (2) (a), (b), (c).

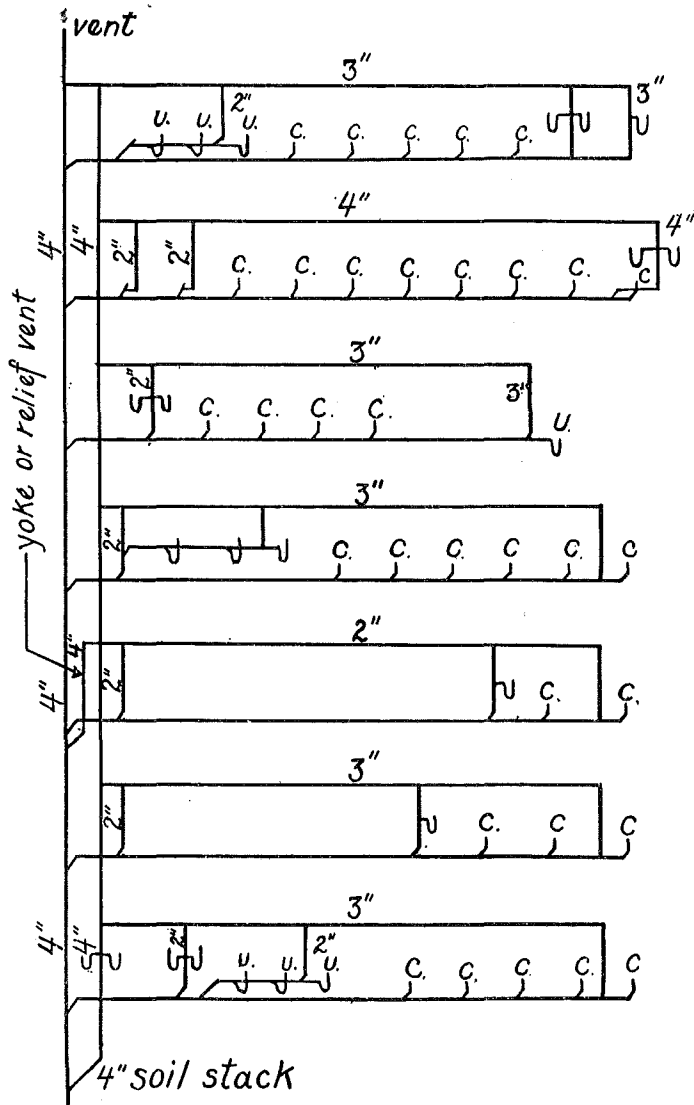

(12) Illustrating typical and various alternative methods of soil, waste and vent piping for tall buildings, including yoke vent, H 62.03 (1), (2); H 62.06 (5); H 62.07 (1), (2) (a), (b), (c), (3).

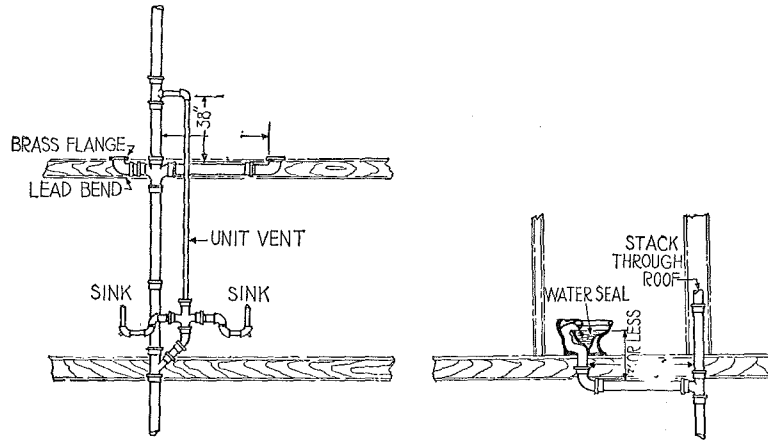

(13) Illustrating provisions of H 62.07 (4), and (7) (a).

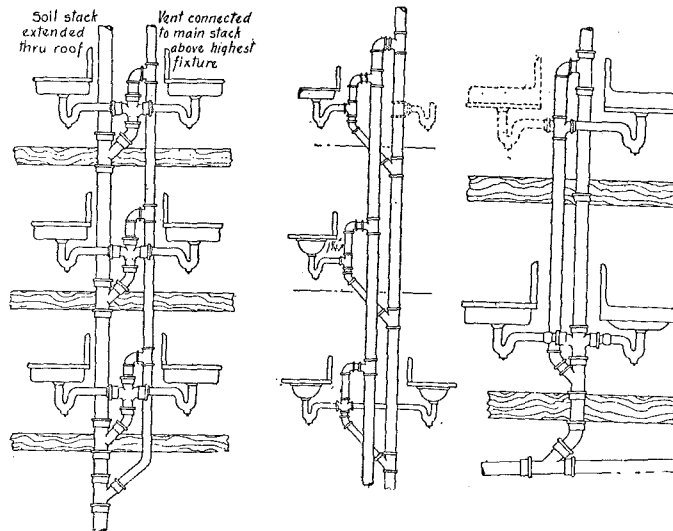

(14) Illustrating provisions of H 62.07 (1) and (4).

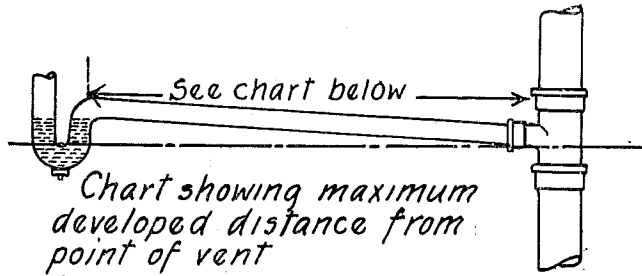

Size of Pipe	Max. Total Grade	Max. Developed Dist.
1 1/4 inch	1 1/4"	2'-6"
1 1/2 inch	1 1/2"	3'-0"
2 inch	2"	4'-0"
3 inch	3"	6'-0"
4 inch	4"	8'-0"

(15) Chart showing maximum developed distance from point of vent. Grade (pitch) not to exceed the inside diameter of the waste branch. H 62.07 (6).

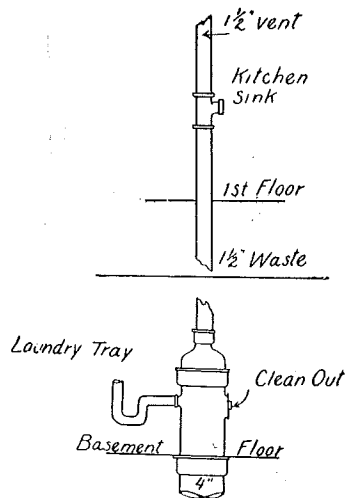

(16) Showing typical laundry tub and kitchen sink installation for single family residence using 1 1/2 inch diameter cleanout plug. H 62.07 (8).

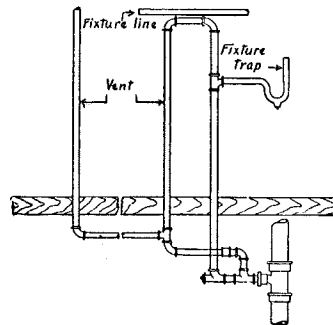

(17) Illustrating method of installing loop vent. H 62.02 (54) (f) and H 62.07 (10).

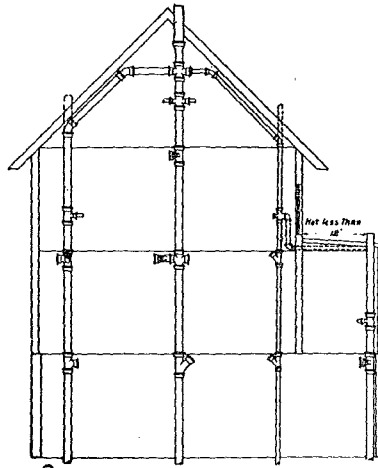

(18) Showing permissible roof terminals and distance from window. H 62.07 (11), (12) (b). See Ind 58.60.

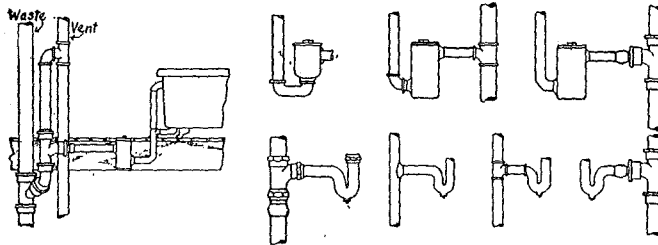

(19) Showing typical traps and methods of back-venting. H 62.07 (6), H 62.08 (1).

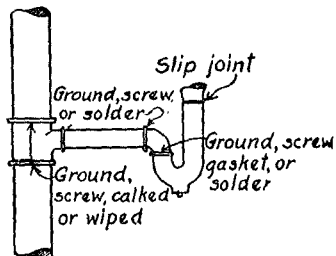

(20) Showing permissible joints in connection with traps. H 62.08 (3) (a), H 62.09 (2), H 62.16 (7).

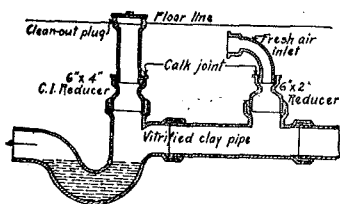

(21) Illustrating vitrified clay main house trap, cleanout, and fresh air inlet installation. H 62.08 (5), H 62.09 (1) (b).

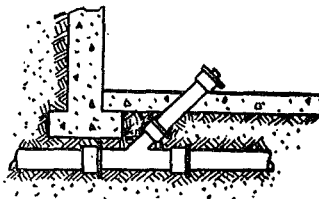

(22) Illustrating main house, drain cleanout plug. Required whether drain enters building below or above floor. H 62.09 (1) (b).

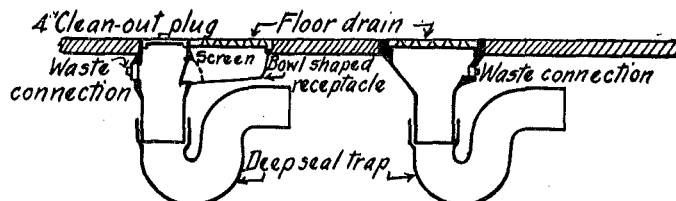

(23) Showing typical floor drains. H 62.10 (1).

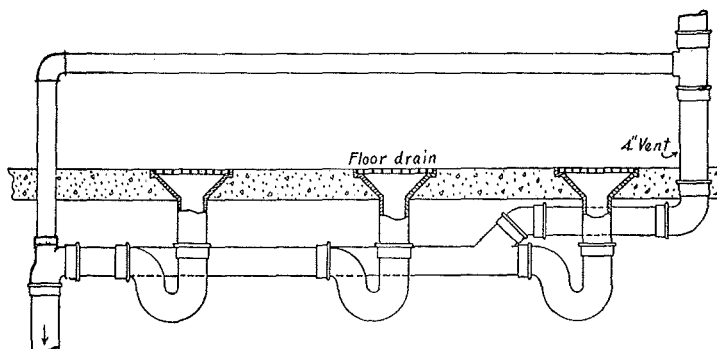

(24) Showing circuit waste and vent method of floor drain installation. H 62.07 (2) (b), H 62.10 (2).

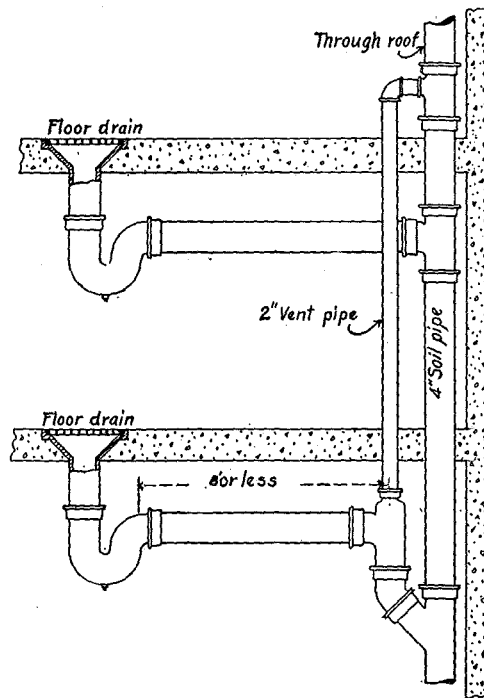

(25) Illustrating individual vent method of installing a floor drain. H 62.10 (2).

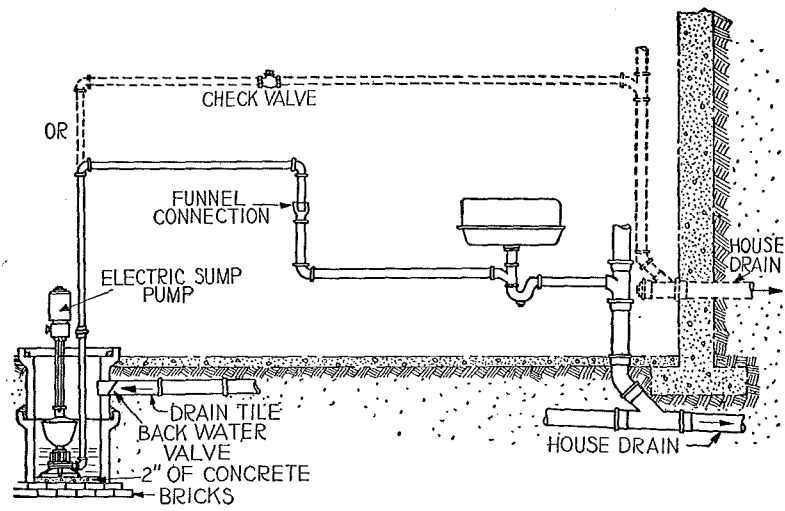

(26) Showing receiver and methods of installation, H 62.11 (7).

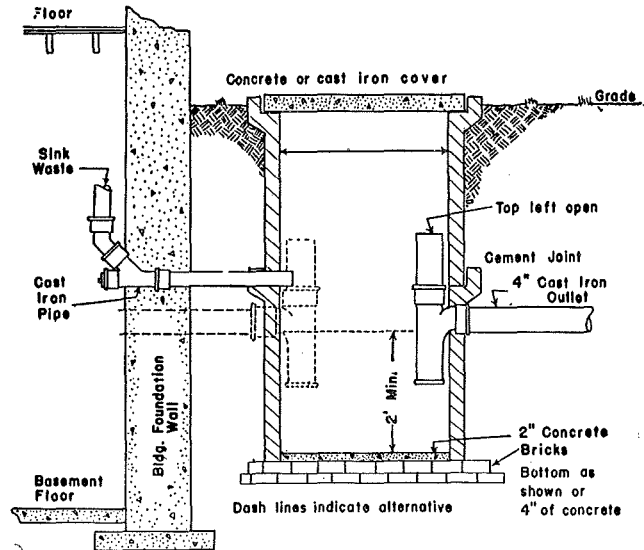

(27) Showing design of drainage piping and grease basin. H 62.11 (2).

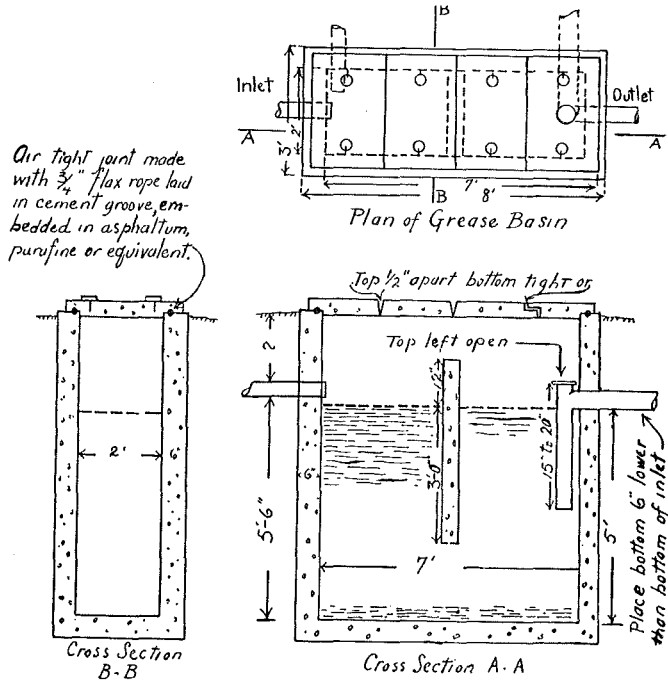

(28) Showing the design of a large grease basin in connection with hotels, restaurants or institution kitchens. H 62.11 (2).

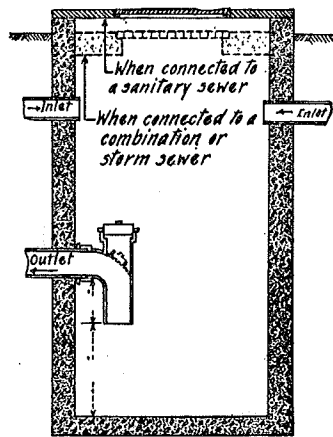

(29) Showing typical outdoor catch basin. H 62.11 (3), (4).

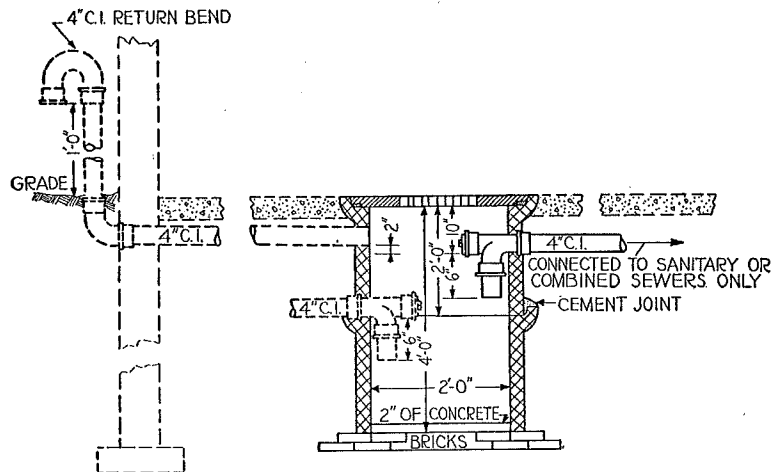

(30) Showing typical garage catch basin. Dash-lines indicate alternative. H 62.11 (5).

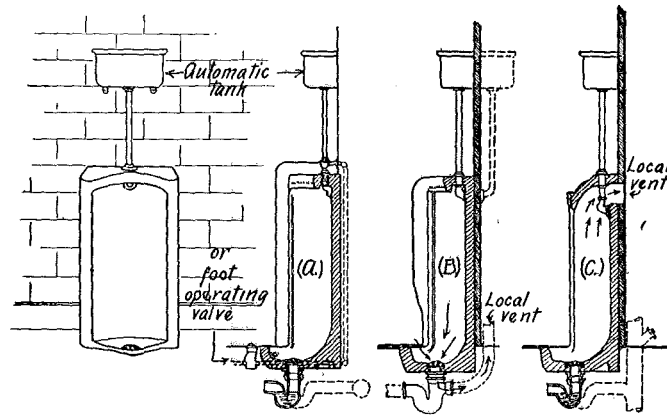

(31) Showing individual urinal set into the floor.
H 62.09 (2), H 62.12 (9).

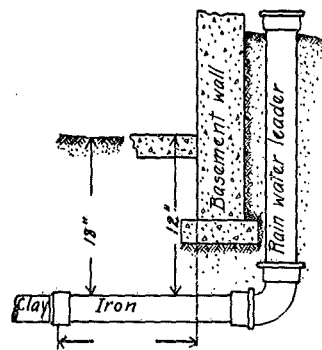

(32) Illustrating method of installing rain water leaders.
H 62.13 (2) (e).

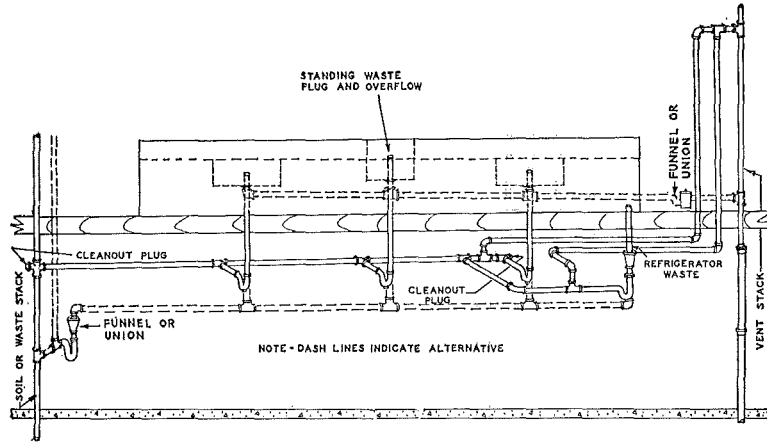

(33) Outlining methods of connecting bar, soda fountain, and similar fixtures. H 62.14 (2).

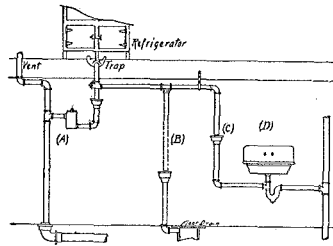

(34) Illustrating methods of connecting refrigerator wastes. H 62.14 (3).

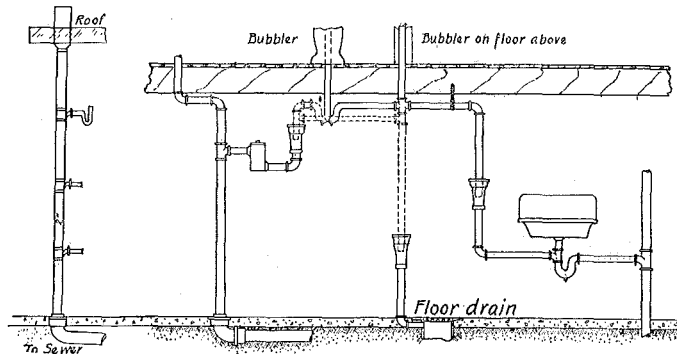

(35) Illustrating four approved methods of connecting drinking fountain wastes. H 62.07 (8), H 62.14 (5).

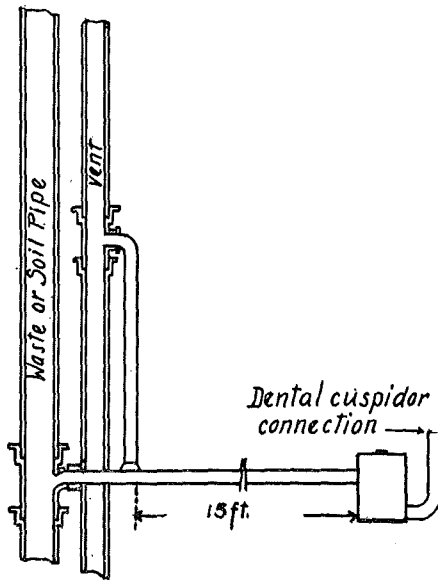

(36) Illustrating a dental cuspidor installation. H 62.14 (6).

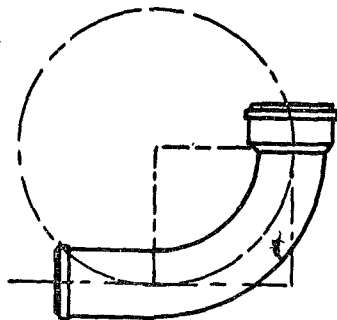

(37) Showing method of determining radius of bends. H 62.15 (3) (b) 2, H 62.16 (12).

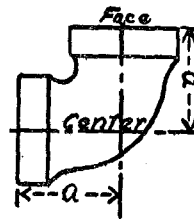

(38) Showing method of determining radius of screw thread drainage fittings. H 62.15 (8), H 62.16 (12).

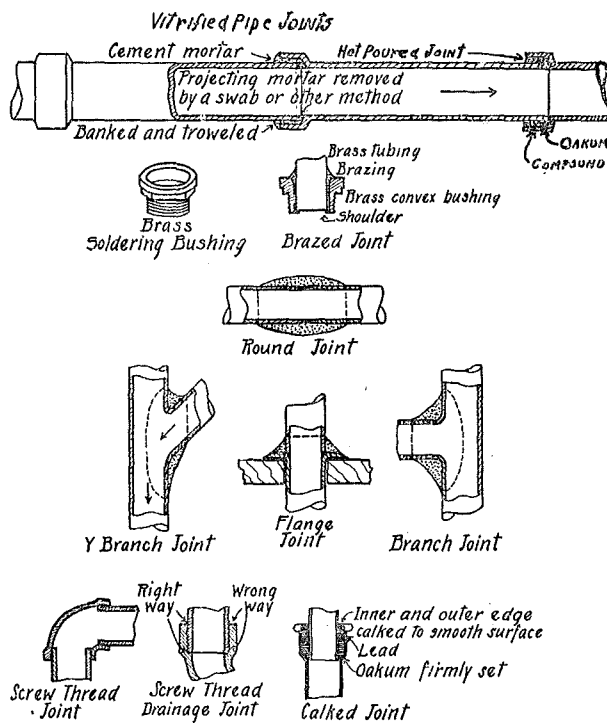

(39) Showing methods of making joints in vitrified clay pipe, cast iron soil pipe, screw thread pipe, wiped joints in lead pipe, and brazed joints in connection with traps. H 62.16 (1).

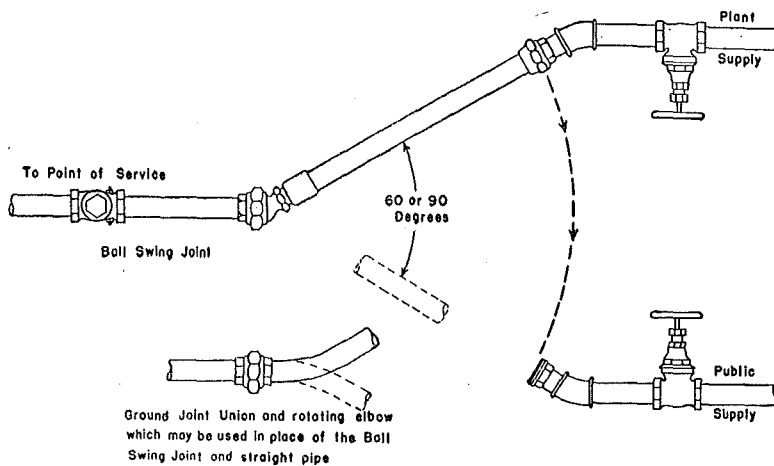

(40) Approved type of service connection with secondary water supplies. H 62.19 (7).

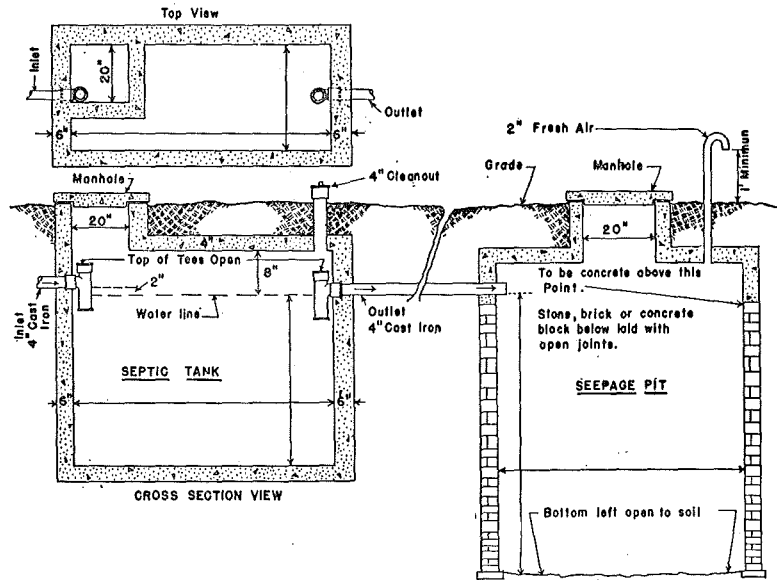

(41) Illustrating a minimum size septic tank and see page pit. H 62.20 (1), (2) (b), (3).

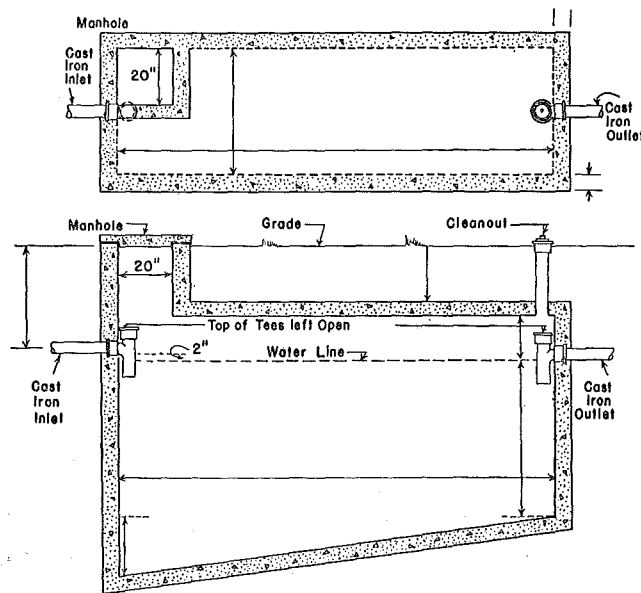

(42) Illustrating a large size septic tank with hopper bottom. H 62.20 (1).

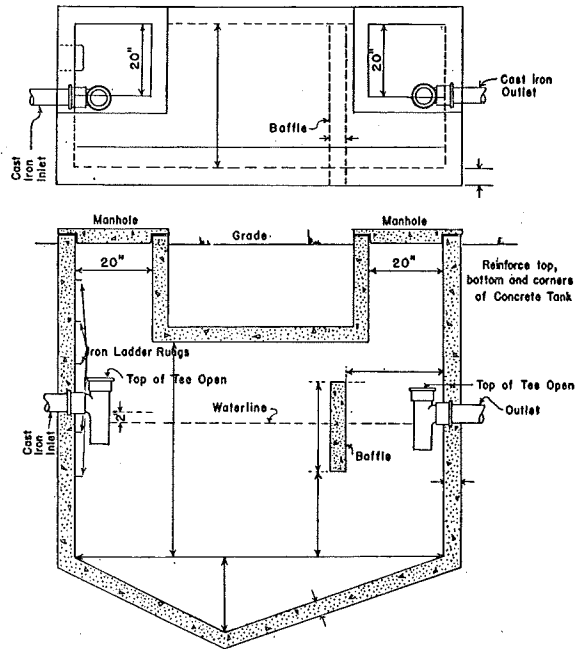

CROSS SECTION OF SEPTIC TANK

(43) Illustrating a large septic tank with hopper bottom and baffle, H 62.20 (1) (e).

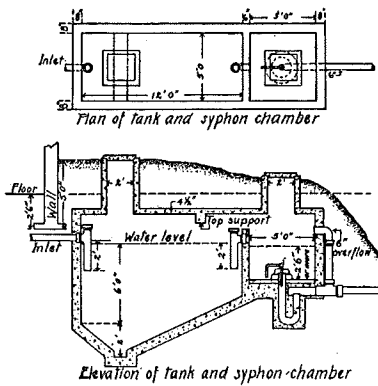

(44) Showing a septic tank equipped with automatic siphon. H 62.20 (2) (c).

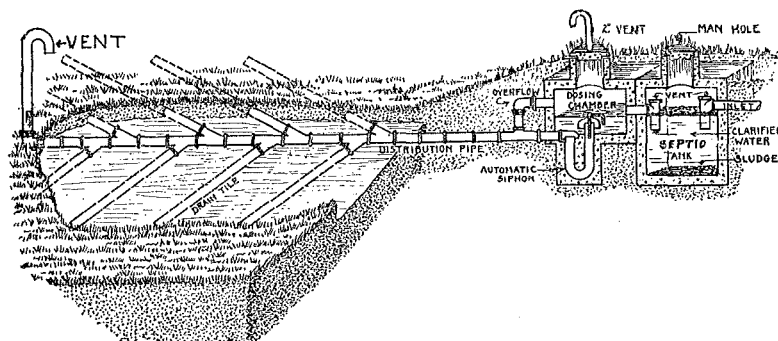

(45) Illustrating sewage disposal system consisting of septic tank, dosing chamber, siphon and drainage tile. H 62.20 (2) (c), (3).

H 62.23 Approval on experimental basis. The board may approve materials, fixtures and layouts different than those set forth in this chapter for specific installations for experimental or trial purposes.

History: Cr. Register, February, 1957, No. 14, eff. 3-1-57.

H 62.24 Industrial commission regulations. The regulations of the industrial commission of Wisconsin pertaining to plumbing, toilet rooms, and sanitation of public buildings shall be followed wherever they are applicable.

Order IND. 4.420.

Orders IND. 17.2200 to IND. 17.2217, inclusive.

Orders IND. 23.5250 to IND. 23.5264, inclusive.

Orders IND. 23.5400 and IND. 23.5412.

Orders IND. 23.5500, IND. 23.5501, IND. 23.5532, IND. 23.5567, and IND. 23.5568 (7).

Orders IND. 23.5600, IND. 23.5611, IND. 23.5612, and IND. 23.5616.

Orders IND. 23.5700, IND. 23.5713, IND. 23.5714, IND. 23.5715 and IND. 23.5716.

Order IND. 24.5848.

History: 1-2-56; renum. from 62.23, Register, February, 1957, No. 14, eff. 3-1-57.