

**APPENDIX  
CHAPTER ILHR 20**

INDUSTRY, LABOR AND HUMAN RELATIONS 127  
Appendix

State of Wisconsin Department of Industry, Labor & Human Relations Division of Safety & Buildings Six 7209 Madison, WI 53707 Wisconsin Statutes 101.63, 131.73	<b>WISCONSIN UNIFORM BUILDING PERMIT APPLICATION</b> <i>(See instructions on back of pink copy)</i>	APPLICATION NO. _____ PARCEL NO. _____
<b>PERMIT REQUESTED</b> <input type="checkbox"/> STRUCTURE <input type="checkbox"/> HVAC <input type="checkbox"/> ELEC <input type="checkbox"/> PLUMBING		
Owner's Name _____		Telephone _____
Contractor's Name _____		Telephone _____
<b>PROJECT LOCATION</b> Building Address _____ Subdivision Name _____		
Zoning District _____ Lot Area _____		Section _____ Lot No. _____ Block No. _____
Setbacks Front _____ Rear _____		Left _____ Right _____
<b>1a. PROJECT</b> <input type="checkbox"/> New <input type="checkbox"/> Alteration <input type="checkbox"/> Other <input type="checkbox"/> Addition <input type="checkbox"/> Repair <input type="checkbox"/> Move <input type="checkbox"/> Raze	<b>3. TYPE</b> <input type="checkbox"/> Single Family <input type="checkbox"/> Two Family <input type="checkbox"/> Other	<b>6. ELECTRICAL</b> Entrance Panel Size _____ amp Service: <input type="checkbox"/> Underground <input type="checkbox"/> Overhead
<b>1b. GARAGE</b> <input type="checkbox"/> Attached <input type="checkbox"/> Detached	<b>4. CONST. TYPE</b> <input type="checkbox"/> Site constructed <input type="checkbox"/> Manufactured	<b>9. HVAC EQUIPMENT</b> <input type="checkbox"/> Forced Air Furnace <input type="checkbox"/> Radiant Baseboard or Panel Heat Pump <input type="checkbox"/> Boiler <input type="checkbox"/> Central Air Conditioning <input type="checkbox"/> Other
<b>2. AREA</b> Basements _____ Sq. ft. Living Area _____ Sq. ft. Garage _____ Sq. ft.	<b>5. STORES</b> <input type="checkbox"/> 1-Story <input type="checkbox"/> 2-Story <input type="checkbox"/> Other	<b>7. FOUNDATION</b> <input type="checkbox"/> Concrete <input type="checkbox"/> Masonry <input type="checkbox"/> Treated Wood <input type="checkbox"/> Other
<b>8. USE</b> <input type="checkbox"/> Seasonal <input type="checkbox"/> Permanent <input type="checkbox"/> Other	<b>10. PLUMBING</b> Sewer: <input type="checkbox"/> Municipal <input type="checkbox"/> Septic Permit No. _____	<b>12. ENERGY SOURCE</b> Fuel: <input type="checkbox"/> Nat'l Gas <input type="checkbox"/> L.P. Gas <input type="checkbox"/> Oil <input type="checkbox"/> Elec <input type="checkbox"/> Solid Solar Space Heat: <input type="checkbox"/> <input type="checkbox"/> <input type="checkbox"/> <input type="checkbox"/> <input type="checkbox"/> <input type="checkbox"/> Water Heat: <input type="checkbox"/> <input type="checkbox"/> <input type="checkbox"/> <input type="checkbox"/> <input type="checkbox"/> <input type="checkbox"/>
		<b>11. WATER</b> <input type="checkbox"/> Municipal Utility <input type="checkbox"/> Private on-site Well
The applicant agrees to comply with the Wisconsin Uniform Dwelling Code and other Municipal Ordinances and with the conditions of this permit, understands that the issuance of the permit creates no legal liability, express or implied, on the Department or Municipality, and certifies that all the above information is accurate.		
SIGNATURE OF APPLICANT _____		DATE _____
<b>CONDITIONS OF APPROVAL</b> This permit is issued pursuant to the following conditions. Failure to comply may result in suspension or revocation of this permit or other penalty.		
<b>ISSUING JURISDICTION</b> <input type="checkbox"/> TOWN <input type="checkbox"/> STATE <input type="checkbox"/> VILLAGE <input type="checkbox"/> INDEPENDENT <input type="checkbox"/> CITY <input type="checkbox"/> COUNTY	Municipality Number of Inspection Authority: _____ Municipality Number of Dwelling Location, if different: _____	
<b>FEES:</b> Plan Review . . . \$ _____ Inspection . . . \$ _____ Wa. Permit Seal(s) \$ _____ Other . . . . . \$ _____ TOTAL . . . \$ _____	<b>PERMIT(S) ISSUED</b> <input type="checkbox"/> Construction <input type="checkbox"/> HVAC <input type="checkbox"/> Electrical <input type="checkbox"/> Plumbing <input type="checkbox"/> Other	<b>WIS. UNIFORM PERMIT SEAL NO.</b> _____
		<b>PERMIT ISSUED BY:</b> NAME _____ DATE _____ CERT. NO. _____

880 5823 (2-84-87)

WHITE - Issuing Jurisdiction

YELLOW - DLUR

GREEN - Inspector

PINK - Owner/Agent

**Site Info**

SUBDIVISION \_\_\_\_\_  
 LOT NO. \_\_\_\_\_ BLOCK NO. \_\_\_\_\_  
 ZONING DISTRICT \_\_\_\_\_  
 \_\_\_\_\_ 1/4, SEC. \_\_\_\_\_, T. \_\_\_\_\_ N., R. \_\_\_\_\_ E or W  
 PARCEL NO. \_\_\_\_\_  
 SETBACKS:  
 FRONT YARD \_\_\_\_\_ foot  
 REAR YARD \_\_\_\_\_ foot  
 LEFT YARD \_\_\_\_\_ foot  
 RIGHT YARD \_\_\_\_\_ foot

**Inspection**

PHASE	RGH	PNL
FOOTING		
FOUNDATION		
CONSTRUCTION		
INSULATION		
PLUMBING		
HEAT/VENT/AC		
ELECTRICAL		
OCCUPANCY		

**NOTICE OF NONCOMPLIANCE**

This Issuing jurisdiction shall notify the applicant in writing of any violations to be corrected. All cited violations shall be corrected within 30 days after notification, unless extension of time is granted.

SBD-6824(R, 05/87)

Keep this card posted until final inspection has been made. Inspections shall be arranged 48 hrs. in advance. Work shall not proceed until the Inspector has approved the various stages of construction or the 48 hr. period since notification has elapsed. This permit will expire 24 months after the date of issuance if construction has not commenced.

**WISCONSIN UNIFORM  
 BUILDING  
 PERMIT# \_\_\_\_\_**

const;  hvac;  elec;  plumb;  
**Project:**

**Issued to**

OWNER (AGENT)
BUILDING SITE ADDRESS
CITY, VILLAGE TOWN, COUNTY

**Issued by**

PERSON ISSUING	CERT. NO.
DATE ISSUED	TELEPHONE NUMBER

affix uniform permit seal here (when applicable)  
 Seal No: \_\_\_\_\_

**COMMENTS:** \_\_\_\_\_  
 \_\_\_\_\_  
 \_\_\_\_\_

WIS. STATS. 101.03

**INDUSTRY, LABOR AND HUMAN RELATIONS** 129  
Appendix

Wisconsin Department of  
 Industry, Labor and Human  
 Relations

**MUNICIPAL RECOMMENDATION  
 FOR A VARIANCE APPLICATION**

Safety and Buildings Division  
 Local Program Services  
 P.O. Box 7969  
 Madison, Wisconsin 53707

Owner Name	Owner Street Address		
City/Town	State	Zip Code	Owner Telephone No.
Dwelling Location	Dwelling Street Address		
City/Town	County		
Agent (Arch - Engr - Contr)	Agent Street Address		
City/Town	State	Zip Code	Agent Telephone No.

1. I have read the application for variance of rule ILHR \_\_\_\_\_
2. I recommend (check appropriate box):  Denial  Approval  Cond. Appr.  No Comment
3. Explanation for recommendation:

4.  I find no conflict with local rules and regulations.  
 I find that the variance is in conflict with local rules and regulations.  
 Explanation:

5. Inspections completed:  None  Footings  Rough  Final  Foundation  
 Bldg. Const  Energy  HVAC  Electrical  Plumbing

6. Correction orders issued:

Municipality exercising jurisdiction: \_\_\_\_\_

Signature of municipal enforcement official:	Date signed:
--	--------------

Please submit this completed form along with original Application for Variance, Form SBD-6070, and \$100.00 state review fee to Department of Industry, Labor and Human Relations at the address shown in the upper right corner.

SBD - 6071 (R. 07/87)

Appendix

State of Wisconsin  
Department of Industry,  
Labor & Human Relations

**RULE VARIANCE APPLICATION UNDER  
WISCONSIN UNIFORM DWELLING CODE**

Safety & Buildings Division  
Local Program Services  
P.O. Box 7969  
Madison, Wisconsin 53707  
(UV)

Owner Name	Owner Street Address	
City	State & Zip Code	Owner Telephone No.
Dwelling Location	Dwelling Street Address	
City/Village/Town	County	
Agent (Arch - Engr - Contr)	Agent Street Address	
City	State & Zip Code	Agent Telephone No.
Municipality Having Jurisdiction	Telephone No.	

\$100 STATE FEE required (ILHR 69.15(2)). Application can only be made by owner. Submit to the address shown in the upper right corner. Additional MUNICIPAL FEE, if any:

1. Rule ILHR \_\_\_\_\_ of the Uniform Dwelling Code cannot be entirely satisfied because:
  
2. In lieu of complying exactly with the rule, the following alternative is proposed as a means of providing an equivalent degree of health, welfare and safety (submit building plans, calculations and specifications to help explain your proposal):
  
3. Supporting arguments are:

**VERIFICATION BY APPLICANT:**

\_\_\_\_\_ verifies that (s)he is the applicant and that all information provided on this application is true to the best of his/her knowledge and belief.

Applicant's Signature \_\_\_\_\_ Date Signed \_\_\_\_\_

Subscribed and sworn to before me

this date \_\_\_\_\_

\_\_\_\_\_  
Notary Public

My commission expires \_\_\_\_\_

FOR OFFICE USE ONLY	
Application No.	Date Received
<input type="checkbox"/> Approved <input type="checkbox"/> Denied	Date Approved/Denied
Official's Name	Title

**APPLICATION IS VALID ONLY IF NOTARIZED AND ACCOMPANIED BY REVIEW FEE.**

SSD 6070 (R. 07.87)

## APPENDIX

## CHAPTER ILHR 21

## FASTENER SCHEDULE TABLE

Description of Building Materials/Connection	Number and Type of Fastener <sup>1 2 3 4</sup>
Joist to sill or girder, toe nail	2-16d, 3-8d
Bridging to joist, toe nail each end	2-8d
1" x 6" subfloor or less to each joist, face nail	2-8d or 2 staples, 1½"
Wider than 1" x 6" subfloor to each joist, face nail	3-8d or 4 staples, 1½"
2" subfloor to joist or girder, blind and face nail	2-16d
Sole plate to joist or blocking, face nail	16d at 16" o.c.
Top or sole plate to stud, end nail	2-16d
Stud to sole plate, toe nail	4-8d or 3-16d
Doubled studs, face nail	16d at 24" o.c.
Doubled top plates, face nail	16d at 16" o.c.
Top plates, laps and intersections, face nail	2-16d
Continuous header, two pieces	16d at 16" o.c. along each edge
Ceiling joists to plate, toe nail	2-16d, 3-8d
Continuous header to stud, toe nail	4-8d
Ceiling joist, laps over partitions, face nail	3-16d
Ceiling joist to parallel rafters, face nail	3-16d
Rafter to plate, toe nail	2-16d, 3-8d
1" brace to each stud and plate, face nail	2-8d or 2 staples, 1½"
1" x 6" sheathing to each bearing, face nail	2-8d or 2 staples, 1½"
1" x 8" sheathing to each bearing, face nail	2-8d or 3 staples, 1½"
Wider than 1" x 8" sheathing to each bearing, face nail	3-8d or 4 staples, 1½"
Built-up corner studs	16d at 30" o.c., 16d at 24" o.c.
Built-up girder and beams	20d at 32" o.c. at top and bottom and staggered 2-20d at ends and at each splice
2-inch planks	2-16d at each bearing
Roof rafters to ridge, valley or hip rafters, toe nail	4-16d
Roof rafters to ridge, valley or hip rafters, face nail	3-16d
Collar ties to rafters, face nail	3-8d
Plywood subfloor, roof and wall sheathing (to framing) <sup>5</sup>	
½-inch to 5/16-inch	6d <sup>5</sup> or staple
¾-inch to ¾-inch	8d smooth or common, 6d deformed, or staple
¾-inch to 1-inch	8d <sup>5</sup>
1½-inch to 1¼-inch	10d smooth or common, or 8d deformed
Fiberboard sheathing <sup>7</sup>	
½-inch	6d common or staple, 1½" long or roofing nail <sup>11</sup>
25/32-inch	8d common or staple, 1½" long or roofing nail <sup>11</sup>
Gypsum sheathing, ½" <sup>8</sup>	1½" galvanized roofing nail, or 6d common, or staple
Particleboard wall sheathing (to framing) <sup>6</sup>	
¾-inch to ½-inch	6d common
¾-inch to ¾-inch	8d common or staple
Insulated sheathing	11-gauge roofing nails, 6d, 8d, or staple
Combination subfloor underlayment (to framing) <sup>6</sup>	
¾-inch and less	6d deformed
¾-inch to 1-inch	8d deformed
1½-inch to 1¼-inch	10d smooth <sup>9</sup> or common or 8d deformed <sup>9</sup>
Panel siding (to framing) <sup>10</sup>	
½-inch or less	6d
¾-inch	8d

<sup>1</sup>All nails are smooth-common, box or deformed shank except where otherwise stated.

<sup>2</sup>Nail is a general description and may be T-head, modified round head or round head.

<sup>3</sup>Staples are 16-gauge wire and have a minimum 7/16-inch o.d. crown width.

<sup>4</sup>Common or box nails may be used except where otherwise stated.

<sup>5</sup>Common or deformed shank.

<sup>6</sup>Nails spaced at 6 inches on center at edges, 12 inches at intermediate supports (10 inches at intermediate supports for floors), except 6 inches at all supports where spans are 48 inches or more.

<sup>7</sup>Nails spaced at 3 inches on center at edges, 6 inches at intermediate supports.

<sup>8</sup>Nails spaced at 4 inches on center at edges, 8 inches at intermediate supports.

<sup>9</sup>Nails spaced at 6 inches on center at edges and at intermediate supports.

<sup>10</sup>Corrosion-resistant siding and casing nails.

<sup>11</sup>Galvanized roofing nails with 7/16-inch diameter head and 1½-inch length for ½-inch sheathing and 1¾-inch for 25/32-inch sheathing.

INDEX OF  
SPAN TABLES FOR JOISTS AND RAFTERS  
(Recommended by National Forest Products Association)

TABLE		PAGE
Table J-1	FLOOR JOISTS, 40 lbs/sq. ft. Live Load	132
Table J-2	FLOOR JOISTS, 30 lbs/sq. ft. Live Load	134
Table J-3	CEILING JOISTS, 20 lbs/sq.ft. Live Load, Plaster Ceiling	136
Table J-4	CEILING JOISTS, 20 lbs/sq.ft. Live Load, Drywall Ceiling	138
Table J-5	CEILING JOISTS, 10 lbs/sq.ft. Live Load, Plaster Ceiling	140
Table J-6	CEILING JOISTS, 10 lbs/sq.ft. Live Load, Drywall Ceiling	142
Table R-2	FLAT OR SLOPED RAFTERS, 30 lbs/sq.ft. Live Load, Drywall Ceiling	144
Table R-3	FLAT OR SLOPED RAFTERS, 40 lbs/sq.ft. Live Load, Drywall Ceiling	148
Table R-5	FLAT OR SLOPED RAFTERS, 30 lbs/sq.ft. Live Load, Plaster Ceiling	152
Table R-6	FLAT OR LOW SLOPED RAFTERS, 40 lbs/sq.ft. Live Load, Plaster Ceiling	156
Table R-8	FLAT OR LOW SLOPED RAFTERS, 30 lbs/sq.ft. Live Load, No Ceiling Load	160
Table R-9	FLAT OR LOW SLOPED RAFTERS, 40 lbs/sq.ft. Live Load, No Ceiling Load	164
Table R-11	MEDIUM OR HIGH SLOPE RAFTERS, 30 lbs/sq.ft. Live Load, No Ceiling Load, Heavy Roof Covering	168
Table R-12	MEDIUM OR HIGH SLOPE RAFTERS, 40 lbs/sq.ft. Live Load, No Ceiling Load, Heavy Roof Covering	172
Table R-14	MEDIUM OR HIGH SLOPE RAFTERS, 30 lbs/sq.ft. Live Load, No Ceiling Load, Light Roof Covering	176
Table R-15	MEDIUM OR HIGH SLOPE RAFTERS, 40 lbs/sq.ft. Live Load, No Ceiling Load, Light Roof Covering	180
Table TSJ-1	TWO SPAN FLOOR JOISTS, 40 lbs/sq.ft. Live Load	184
Table TSJ-2	TWO SPAN FLOOR JOISTS, 30 lbs/sq.ft. Live Load	186

SPAN TABLES FOR JOISTS AND RAFTERS  
(Recommended by National Forest Products Association)

EXPLANATION OF TABLES

These span tables for joists and rafters are calculated on the basis of a series of modulus of elasticity (E) and fiber bending stress ( $F_b$ ) values. The range of values in the tables provides allowable spans for all species and grades of nominal 2-inch framing lumber customarily used in construction.

Tables J-1 through J-6 list spans for floor and ceiling joists used over a single span with calculations based on E and the required  $F_b$  values shown.

Tables R-2 through R-15 list spans for rafters used over a single span with calculations based on  $F_b$  and the required E values shown.

Tables TSJ-1 and TSJ-2 list spans for floor joists continuous over two equal spans with calculations based on E and the required  $F_b$  values shown.

Applicable design criteria for each condition of use appear at the top of each table. While these criteria are directed principally to residential construction, they are suitable for other occupancies having similar conditions of loading. Tabulated spans for rafters also apply to other types of occupancy, since the occupancy has little bearing on roof loading.

#### LUMBER SIZES

Tabulated spans apply to surfaced (S4S) lumber having dimensions which conform to the American Softwood Lumber Standard, PS 20-70. These sizes are as follows:

Reference	Dressed Size (inches)	
	Surfaced Dry	Surfaced Green
2 x 4	1½ x 3½	1-9/16 x 3-9/16
2 x 6	1½ x 5½	1-9/16 x 5½
2 x 8	1½ x 7¼	1-9/16 x 7¼
2 x 10	1½ x 9¼	1-9/16 x 9¼
2 x 12	1½ x 11¼	1-9/16 x 11¼

#### MOISTURE CONTENT

The listed dry and green sizes are related at 19% maximum moisture content. Tabulated spans are calculated on the basis of the dry sizes and are also applicable to the corresponding green sizes. The spans in these tables are intended for use in covered structures or where moisture content in use does not exceed 19%.

#### SPAN MEASUREMENT

Tabulated spans are the clear distance between supports. For sloping rafters, the span is measured along the horizontal projection.

#### LUMBER DESIGN VALUES

Use of these span tables requires reference to the applicable design values for the various species and grades of lumber. "Design Values for Joists and Rafters", a supplement to these span tables, provide such values in convenient-to-use form. Modulus of elasticity (E) and fiber bending stress ( $F_b$ ) values therein are based on the National Design Specification for Wood Construction (formerly National Design Specification for Stress Grade Lumber and Its Fastenings) and incorporate adjustments appropriate for repetitive-member use under various durations of load.

Repetitive-member use is that condition where framing members such as joists, rafters, studs, planks, decking or similar members are spaced not more than 24 inches, are not less than 3 in number and are joined by floor, roof or other load-distributing elements adequate to support the



design load. Design values in bending ( $F_b$ ) for such use are 15% greater than for single-member use.

The "Joists" column in the design value tables provide values for bending for repetitive-member use under normal conditions. The "Rafters" column of the design value tables provide values for bending for repetitive-member use adjusted for snow-loading.

#### ROOF LOADS

Rafter spans are tabulated for the most common roof loads. For roof loads intermediate between those tabulated, straight line interpolation may be used.

Light roof coverings are defined as those with a weight of 7 psf or less and typically include asphalt and wood shingles. Heavy roof coverings are those which are more than 7 psf, up to 15 psf, and typically include tile and slate roofs.

#### LUMBER IDENTIFICATION

When used with the tabulated spans in these tables, lumber should be identified by the grademark of an agency recognized as being competent by the Board of Review of the American Lumber Standards Committee or the Canadian Lumber Standards Administrative Board.

#### USE OF THE SPAN TABLES

Spans for floor and ceiling joists are calculated on the basis of the modulus of elasticity ( $E$ ) with the required fiber bending stress ( $F_b$ ) listed below each span. Spans for rafters are calculated on the basis of fiber bending stress ( $F_b$ ) with the required modulus of elasticity ( $E$ ) listed below each span. Use of the tables is illustrated in the examples which follow.

Example 1. Floor joists. Assume a required span of 12'-9", a live load of 40 psf and joists spaced 16 inches on centers. Table J-1 shows that a grade of 2 x 8 having an  $E$  value of 1,600,000 psi and an  $F_b$  value of 1250 psi would have a span of 12'-10", which satisfies the condition.

Example 2. Low slope rafter (3 in 12 slope or less) with no ceiling load. Assume a horizontal projection of 13'-0", a live load of 30 psf, dead load of 10 psf and 16" o.c. spacing. Table R-8 shows that 2x8 having a  $F_b$  value of 1100 psi and  $E$  value of 920,000 psi would have an allowable span of 13'-5" of horizontal projection.

Since many combinations of size, spacing,  $E$  and ( $F_b$ ) values are possible, it is recommended that the users examine the tables to determine which combination fits their particular case most effectively.

TABLE J-1  
FLOOR JOISTS  
40 Lbs. Per Sq. Ft. Live Load  
(All floors except attic floors.)

DESIGN CRITERIA:  
Deflection - For 40 lbs. per sq. ft. live load,  
Limited to span in inches divided by 360.  
Strength - Live Load of 40 lbs. per sq. ft. plus  
dead load of 10 lbs. per sq. ft. determines the  
required fiber stress value.

JOIST SIZE SPACING (IN)	Modulus of Elasticity, "E", in 1,000,000 psi																			
	0.4	0.5	0.6	0.7	0.8	0.9	1.0	1.1	1.2	1.3	1.4	1.5	1.6	1.7	1.8	1.9	2.0	2.2	2.4	
12.0	6-9	7-3	7-9	8-2	8-6	8-10	9-2	9-6	9-9	10-0	10-3	10-6	10-9	10-11	11-2	11-4	11-7	11-11	12-3	
	4-50	5-20	5-90	6-60	7-20	7-80	8-50	8-90	9-40	9-80	10-40	10-80	11-40	11-90	12-30	12-80	13-20	14-10	14-90	
	6-6	7-0	7-5	7-9	8-2	8-6	8-9	9-1	9-4	9-7	9-10	10-0	10-3	10-6	10-8	10-10	11-1	11-5	11-9	
	13.7	4-70	5-50	6-20	6-90	7-50	8-10	8-70	9-30	9-80	10-40	10-90	11-40	11-90	12-40	12-90	13-40	14-70	15-60	
	16.0	5-00	6-7	7-0	7-5	7-9	8-0	8-4	8-7	8-10	9-1	9-4	9-6	9-9	9-11	10-2	10-4	10-6	10-10	11-2
2x8	5-9	6-3	6-7	7-0	7-3	7-7	7-10	8-1	8-4	8-7	8-9	9-0	9-2	9-4	9-6	9-8	9-10	10-2	10-6	
	19.2	5-30	6-10	6-90	7-70	8-40	9-10	10-40	11-00	11-60	12-20	12-80	13-40	13-90	14-40	15-00	15-50	16-50	17-50	
	5-4	5-9	6-2	6-6	6-9	7-0	7-3	7-6	7-9	7-11	8-2	8-4	8-6	8-8	8-10	9-0	9-2	9-6	9-8	
	24.0	5-70	6-50	7-30	8-00	8-80	9-50	10-20	11-00	11-80	12-50	13-10	13-80	14-40	15-00	15-50	16-10	16-70	17-80	
	32.0					6-2	6-5	6-7	6-10	7-0	7-3	7-5	7-7	7-9	7-11	8-0	8-2	8-4	8-7	8-10
2x10	8-11	9-7	10-2	10-9	11-3	11-8	12-1	12-6	12-10	13-2	13-6	13-10	14-2	14-5	14-8	15-0	15-3	15-9	16-2	
	12.0	4-50	5-20	5-90	6-60	7-20	7-80	8-50	9-10	9-80	10-40	10-80	11-40	11-90	12-30	12-80	13-20	14-10	14-90	
	8-6	9-2	9-8	10-3	10-9	11-2	11-7	11-11	12-3	12-7	12-11	13-3	13-6	13-10	14-1	14-4	14-7	15-0	15-6	
	13.7	4-70	5-50	6-20	6-90	7-50	8-10	8-70	9-30	9-80	10-40	10-90	11-40	11-90	12-40	12-90	13-40	14-70	15-60	
	16.0	5-00	5-80	6-50	7-20	7-90	8-50	9-20	9-90	10-40	10-90	11-40	11-90	12-40	12-90	13-40	14-10	14-60	15-50	
2x12	8-1	8-9	9-3	9-9	10-2	10-7	11-0	11-4	11-8	12-0	12-3	12-7	12-10	13-1	13-4	13-7	13-10	14-3	14-8	
	19.2	5-00	5-80	6-50	7-20	7-90	8-50	9-20	9-90	10-40	10-90	11-40	11-90	12-40	12-90	13-40	14-10	14-60	15-50	
	7-2	8-2	8-9	9-2	9-7	10-0	10-4	10-8	11-0	11-3	11-7	11-10	12-1	12-4	12-7	12-10	13-0	13-5	13-10	
	24.0	5-30	6-10	6-90	7-70	8-40	9-10	9-70	10-40	11-00	11-60	12-20	12-80	13-40	13-90	14-40	15-00	15-50	16-50	
	32.0	7-1	7-7	8-1	8-6	8-11	9-3	9-7	9-11	10-2	10-5	10-9	11-0	11-2	11-5	11-8	11-11	12-1	12-6	12-10
32.0	7-1	7-7	8-1	8-6	8-11	9-3	9-7	9-11	10-2	10-5	10-9	11-0	11-2	11-5	11-8	11-11	12-1	12-6	12-10	
	24.0	5-70	6-50	7-30	8-00	8-80	9-50	10-20	11-00	11-80	12-50	13-10	13-80	14-40	15-00	15-50	16-10	16-70	17-80	
	8-1	8-5	8-9	9-0	9-3	9-5	9-9	10-0	10-2	10-5	10-9	11-0	11-2	11-5	11-8	11-11	12-1	12-6	12-10	
	32.0					8-1	8-5	8-9	9-0	9-3	9-5	9-9	10-0	10-2	10-5	10-7	10-10	11-4	11-8	
						8-1	8-5	8-9	9-0	9-3	9-5	9-9	10-0	10-2	10-5	10-7	10-10	11-4	11-8	

WISCONSIN ADMINISTRATIVE CODE

2x10	12.0	11.4	12.3	13.0	13.8	14.4	14.11	15.5	15.11	15.5	16.5	16.70	17.3	17.8	18.0	18.5	18.9	19.1	19.5	20.1	20.8		
		450	520	590	660	720	780	830	890	940	990	1040	1090	1140	1190	1230	1280	1320	1370	1410	1460	1490	
	13.7	10.10	11.8	12.5	13.1	13.8	14.3	14.9	15.3	15.8	16.1	16.5	16.6	16.11	17.3	17.7	17.11	19.3	19.7	19.2	19.9	15.60	
		470	550	620	690	750	810	870	920	980	1040	1090	1140	1190	1240	1290	1340	1390	1440	1490	1540	1560	
		10.4	11.1	11.10	12.5	13.0	13.6	14.0	14.5	14.11	15.3	15.9	16.0	16.5	16.9	17.0	17.4	17.8	18.3	18.3	18.3	18.3	18.3
		500	580	650	720	790	850	920	980	1040	1090	1150	1200	1250	1310	1360	1410	1460	1510	1560	1610	1640	1640
		9.9	10.5	11.1	11.8	12.3	12.9	13.2	13.7	14.0	14.5	14.9	15.1	15.5	15.9	16.0	16.4	16.7	17.2	17.2	17.2	17.3	17.3
		530	610	690	770	840	910	970	1040	1100	1160	1220	1280	1330	1390	1440	1500	1550	1600	1650	1700	1750	
		9.0	9.9	10.4	10.10	11.4	11.10	12.3	12.8	13.0	13.4	13.8	14.0	14.4	14.7	14.11	15.2	15.5	15.11	15.11	15.11	15.11	15.11
		570	660	750	830	900	980	1050	1120	1190	1250	1310	1360	1410	1460	1510	1560	1610	1660	1710	1760	1810	
2x12	32.0					10.4	10.9	11.1	11.5	11.10	12.2	12.5	12.9	13.0	13.0	13.0	13.0	13.0	13.0	13.0	13.0	13.0	
		13.10	14.11	15.10	16.9	17.5	18.1	18.9	19.4	19.11	20.6	21.0	21.6	21.11	22.5	22.10	23.3	23.7	24.5	25.1	25.1	25.1	
	12.0	450	520	590	660	720	780	830	890	940	990	1040	1090	1140	1190	1230	1280	1320	1410	1490	1490		
	13.7	470	550	620	690	750	810	870	920	980	1040	1090	1140	1190	1240	1290	1340	1390	1470	1560	1560		
		12.7	13.6	14.4	15.2	15.10	16.5	17.0	17.7	18.1	18.7	19.1	19.5	19.11	20.4	20.9	21.1	21.6	22.2	22.4	22.4	22.4	
	16.0	500	580	650	720	780	850	920	980	1040	1090	1150	1200	1250	1310	1360	1410	1460	1510	1560	1640	1640	
		11.0	12.9	13.6	14.3	14.11	15.6	16.0	16.7	17.0	17.6	17.11	18.4	18.9	19.2	19.6	19.10	20.2	20.7	21.6	21.6	21.6	
	19.2	530	610	690	770	840	910	970	1040	1100	1160	1220	1280	1330	1390	1440	1500	1550	1600	1650	1750	1750	
		11.0	11.10	12.7	13.3	13.10	14.4	14.11	15.4	15.10	16.3	16.8	17.0	17.5	17.9	18.1	18.5	18.9	19.4	19.11	19.11	19.11	
	24.0	570	660	750	830	900	980	1050	1120	1190	1250	1310	1360	1410	1460	1510	1560	1610	1660	1710	1760	1810	
32.0						12.7	13.1	13.6	13.11	14.4	14.9	15.2	15.6	15.10	16.2	16.5	16.8	17.0	17.7	18.1	18.1		
						1000	1080	1150	1220	1300	1380	1450	1520	1590	1650	1700	1770	1830	1890	1950	2070		

Note: The required extreme fiber stress in bending, "F<sub>b</sub>", in pounds per square inch is shown below each span.

TABLE J-2  
FLOOR JOISTS  
30 lbs. Per Sq. Ft. Live Load  
(Optional table for attic floors.)

DESIGN CRITERIA:  
Deflection - For 30 lbs. per sq. ft. live load,  
L limited to span in inches divided by 360.  
Strength - Live Load of 30 lbs. per sq. ft. plus  
dead load of 10 lbs. per sq. ft. determines  
the required fiber stress value.

JOIST SIZE SPACING (IN)	Modulus of Elasticity, "E", in 1,000,000 psi																			
	0.4	0.5	0.6	0.7	0.8	0.9	1.0	1.1	1.2	1.3	1.4	1.5	1.6	1.7	1.8	1.9	2.0	2.2	2.4	
12.0	7.5	8.0	8.6	9.1	9.4	9.9	10.1	10.5	10.9	11.0	11.3	11.7	11.10	12.0	12.3	12.6	12.9	13.1	13.6	
	4.0	4.4	5.0	5.7	6.0	7.0	8.0	8.6	9.1	9.6	10.1	10.6	11.0	11.5	12.0	12.4	12.8	13.7	14.6	
	7.1	7.8	8.2	8.7	9.1	9.4	9.8	10.0	10.3	10.6	10.10	11.1	11.3	11.6	11.9	12.2	12.7	12.7	12.7	
13.7	4.0	4.6	5.0	5.7	6.0	7.0	8.0	8.6	9.1	9.6	10.1	10.6	11.0	11.5	12.0	12.4	12.8	13.7	14.6	
	6.9	7.3	7.9	8.2	8.6	8.10	9.2	9.6	9.9	10.0	10.3	10.6	10.8	10.11	11.2	11.4	11.7	11.7	12.3	
	6.4	6.10	7.3	7.8	8.0	8.4	8.8	8.11	9.2	9.5	9.8	9.10	10.1	10.4	10.6	10.9	10.10	11.3	11.7	
16.0	5.1	5.4	6.9	7.1	7.5	7.9	8.0	8.3	8.6	8.9	9.1	9.2	9.4	9.7	9.9	9.11	10.1	10.5	10.9	
	5.0	5.5	6.4	7.0	8.0	8.8	9.5	10.0	10.8	11.5	12.0	12.3	13.0	13.8	14.5	15.0	15.6	16.0	16.9	
	6.8	7.0	7.3	7.9	12.4	12.10	13.4	13.9	14.2	14.6	14.11	15.3	15.7	15.10	16.2	16.6	16.9	17.4	17.10	
19.2	9.10	10.7	11.3	11.7	12.4	12.10	13.4	13.9	14.2	14.6	14.11	15.3	15.7	15.10	16.2	16.6	16.9	17.4	17.10	
	4.0	4.4	5.0	5.7	6.0	7.0	8.0	8.6	9.1	9.6	10.1	10.6	11.0	11.5	12.0	12.4	12.8	13.7	14.6	
	9.4	10.1	10.9	11.4	11.10	12.3	12.9	13.2	13.6	13.11	14.3	14.7	14.11	15.2	15.6	15.9	16.0	16.7	17.0	
24.0	8.11	9.7	10.2	10.9	11.3	11.8	12.1	12.6	12.10	13.2	13.6	14.0	14.2	14.5	14.8	15.0	15.3	15.9	16.2	
	4.8	5.0	5.9	7.0	7.7	8.5	8.9	9.5	10.0	10.6	11.0	11.5	12.0	12.7	13.0	13.6	14.0	14.5	15.0	
	8.5	9.0	9.7	10.1	10.7	11.0	11.4	11.9	12.1	12.5	12.9	13.0	13.4	13.7	13.10	14.1	14.4	14.9	15.3	
32.0	5.10	6.0	6.7	7.4	8.0	8.8	9.4	10.1	10.7	11.3	11.8	12.4	12.8	13.5	14.0	14.5	15.0	15.6	16.0	
	7.9	8.5	9.1	9.4	9.10	10.2	10.7	11.3	11.8	12.1	12.4	12.7	13.0	13.3	13.6	13.9	14.2	14.5	14.8	
	5.0	5.5	6.4	7.0	8.0	8.8	9.5	10.0	10.8	11.5	12.0	12.7	13.0	13.8	14.5	15.0	15.6	16.0	16.9	
32.0	8.11	9.7	10.2	10.9	11.3	11.8	12.1	12.6	12.10	13.2	13.6	14.0	14.2	14.5	14.8	15.0	15.3	15.9	16.2	
	4.8	5.0	5.9	7.0	7.7	8.5	8.9	9.5	10.0	10.6	11.0	11.5	12.0	12.7	13.0	13.6	14.0	14.5	15.0	
	8.5	9.0	9.7	10.1	10.7	11.0	11.4	11.9	12.1	12.5	12.9	13.0	13.4	13.7	13.10	14.1	14.4	14.9	15.3	
32.0	7.9	8.5	9.1	9.4	9.10	10.2	10.7	11.3	11.8	12.1	12.4	12.7	13.0	13.3	13.6	13.9	14.2	14.5	14.8	
	5.0	5.5	6.4	7.0	8.0	8.8	9.5	10.0	10.8	11.5	12.0	12.7	13.0	13.8	14.5	15.0	15.6	16.0	16.9	
	8.11	9.7	10.2	10.9	11.3	11.8	12.1	12.6	12.10	13.2	13.6	14.0	14.2	14.5	14.8	15.0	15.3	15.9	16.2	
32.0	4.8	5.0	5.9	7.0	7.7	8.5	8.9	9.5	10.0	10.6	11.0	11.5	12.0	12.7	13.0	13.6	14.0	14.5	15.0	
	8.5	9.0	9.7	10.1	10.7	11.0	11.4	11.9	12.1	12.5	12.9	13.0	13.4	13.7	13.10	14.1	14.4	14.9	15.3	
	7.9	8.5	9.1	9.4	9.10	10.2	10.7	11.3	11.8	12.1	12.4	12.7	13.0	13.3	13.6	13.9	14.2	14.5	14.8	
32.0	5.0	5.5	6.4	7.0	8.0	8.8	9.5	10.0	10.8	11.5	12.0	12.7	13.0	13.8	14.5	15.0	15.6	16.0	16.9	
	8.11	9.7	10.2	10.9	11.3	11.8	12.1	12.6	12.10	13.2	13.6	14.0	14.2	14.5	14.8	15.0	15.3	15.9	16.2	
	4.8	5.0	5.9	7.0	7.7	8.5	8.9	9.5	10.0	10.6	11.0	11.5	12.0	12.7	13.0	13.6	14.0	14.5	15.0	

Appendix

2x10	12.0	44.0	12.6	13.6	14.4	15.1	15.9	16.5	17.0	17.6	18.0	18.6	19.0	19.5	19.10	20.3	20.8	21.0	21.5	22.1	22.9
		48.0	11.1	12.1	13.0	14.5	15.1	15.8	16.3	16.9	17.3	17.9	18.2	18.7	19.0	19.4	19.8	20.1	20.5	21.1	21.8
		52.0	11.4	12.3	13.0	14.4	15.1	15.8	16.3	16.9	17.3	17.9	18.2	18.7	19.0	19.4	19.8	20.1	20.5	21.1	21.8
		56.0	11.4	12.3	13.0	14.4	15.1	15.8	16.3	16.9	17.3	17.9	18.2	18.7	19.0	19.4	19.8	20.1	20.5	21.1	21.8
		60.0	11.4	12.3	13.0	14.4	15.1	15.8	16.3	16.9	17.3	17.9	18.2	18.7	19.0	19.4	19.8	20.1	20.5	21.1	21.8
		64.0	11.4	12.3	13.0	14.4	15.1	15.8	16.3	16.9	17.3	17.9	18.2	18.7	19.0	19.4	19.8	20.1	20.5	21.1	21.8
		68.0	11.4	12.3	13.0	14.4	15.1	15.8	16.3	16.9	17.3	17.9	18.2	18.7	19.0	19.4	19.8	20.1	20.5	21.1	21.8
		72.0	11.4	12.3	13.0	14.4	15.1	15.8	16.3	16.9	17.3	17.9	18.2	18.7	19.0	19.4	19.8	20.1	20.5	21.1	21.8
		76.0	11.4	12.3	13.0	14.4	15.1	15.8	16.3	16.9	17.3	17.9	18.2	18.7	19.0	19.4	19.8	20.1	20.5	21.1	21.8
		80.0	11.4	12.3	13.0	14.4	15.1	15.8	16.3	16.9	17.3	17.9	18.2	18.7	19.0	19.4	19.8	20.1	20.5	21.1	21.8
2x12	12.0	44.0	12.6	13.6	14.4	15.1	15.9	16.5	17.0	17.6	18.0	18.6	19.0	19.5	19.10	20.3	20.8	21.0	21.5	22.1	22.9
		48.0	11.1	12.1	13.0	14.5	15.1	15.8	16.3	16.9	17.3	17.9	18.2	18.7	19.0	19.4	19.8	20.1	20.5	21.1	21.8
		52.0	11.4	12.3	13.0	14.4	15.1	15.8	16.3	16.9	17.3	17.9	18.2	18.7	19.0	19.4	19.8	20.1	20.5	21.1	21.8
		56.0	11.4	12.3	13.0	14.4	15.1	15.8	16.3	16.9	17.3	17.9	18.2	18.7	19.0	19.4	19.8	20.1	20.5	21.1	21.8
		60.0	11.4	12.3	13.0	14.4	15.1	15.8	16.3	16.9	17.3	17.9	18.2	18.7	19.0	19.4	19.8	20.1	20.5	21.1	21.8
		64.0	11.4	12.3	13.0	14.4	15.1	15.8	16.3	16.9	17.3	17.9	18.2	18.7	19.0	19.4	19.8	20.1	20.5	21.1	21.8
		68.0	11.4	12.3	13.0	14.4	15.1	15.8	16.3	16.9	17.3	17.9	18.2	18.7	19.0	19.4	19.8	20.1	20.5	21.1	21.8
		72.0	11.4	12.3	13.0	14.4	15.1	15.8	16.3	16.9	17.3	17.9	18.2	18.7	19.0	19.4	19.8	20.1	20.5	21.1	21.8
		76.0	11.4	12.3	13.0	14.4	15.1	15.8	16.3	16.9	17.3	17.9	18.2	18.7	19.0	19.4	19.8	20.1	20.5	21.1	21.8
		80.0	11.4	12.3	13.0	14.4	15.1	15.8	16.3	16.9	17.3	17.9	18.2	18.7	19.0	19.4	19.8	20.1	20.5	21.1	21.8

Note: The required extreme fiber stress in bending, "F<sub>b</sub>", in pounds per square inch is shown below each span.

TABLE J-3  
CEILING JOISTS

20 Lbs. Per Sq. Ft. Live Load  
(Limited attic storage where development of future rooms is not possible)  
(Plaster Ceiling)

DESIGN CRITERIA:  
Deflection - For 20 lbs. per sq. ft. live load,  
Limited to span in inches divided by 360.  
Strength - Live load of 20 lbs. per sq. ft. plus  
dead load of 10 lbs. per sq. ft. determines  
required fiber stress value.

JOIST SIZE SPACING (IN)	Modulus of Elasticity, "E", in 1,000,000 psi																			
	0.4	0.5	0.6	0.7	0.8	0.9	1.0	1.1	1.2	1.3	1.4	1.5	1.6	1.7	1.8	1.9	2.0	2.2	2.4	
12.0	5-5	5-10	6-2	6-6	6-10	7-1	7-4	7-7	7-10	8-0	8-3	8-5	8-7	8-9	8-11	9-1	9-3	9-7	9-10	
	4-30	500	560	630	680	740	790	850	900	950	990	1040	1090	1130	1170	1220	1260	1340	1420	
	5-2	5-7	5-11	5-3	6-6	6-9	7-0	7-3	7-6	7-8	7-10	8-1	8-3	8-5	8-7	8-8	8-10	9-2	9-5	
	4-50	520	580	650	720	770	830	880	940	990	1040	1090	1140	1180	1230	1270	1320	1400	1490	
16.0	4-11	5-4	5-8	5-11	6-2	6-5	6-8	6-11	7-1	7-3	7-6	7-8	7-10	8-0	8-1	8-3	8-5	8-8	8-11	
	4-70	550	620	690	750	810	870	930	990	1040	1090	1140	1200	1240	1290	1340	1390	1480	1570	
	4-8	5-0	5-4	5-7	5-10	5-1	5-3	5-6	5-9	6-10	7-0	7-2	7-4	7-5	7-8	7-9	7-11	8-2	8-5	
	5-00	580	660	730	800	870	930	990	1050	1110	1160	1220	1270	1320	1370	1420	1470	1570	1660	
24.0	4-4	4-8	4-11	5-2	5-5	5-8	5-10	6-0	6-2	6-4	6-6	6-8	6-10	7-0	7-1	7-3	7-4	7-7	7-10	
	5-40	630	710	790	860	930	1000	1070	1130	1190	1250	1310	1370	1420	1480	1530	1590	1690	1790	
	8-5	9-2	9-9	10-3	10-9	11-2	11-7	11-11	12-3	12-7	12-11	13-3	13-6	13-9	14-1	14-4	14-7	15-0	15-6	
	4-30	500	560	630	680	740	790	850	900	950	990	1040	1090	1150	1170	1220	1280	1340	1420	
13.7	8-2	8-9	9-4	9-10	10-3	10-8	11-1	11-5	11-9	12-1	12-4	12-8	12-11	13-2	13-5	13-8	13-11	14-4	14-9	
	4-50	520	590	650	720	770	830	880	940	990	1040	1090	1140	1180	1230	1270	1320	1400	1490	
	7-9	8-4	8-10	9-4	9-9	10-2	10-6	10-10	11-2	11-5	11-9	12-0	12-3	12-6	12-9	13-0	13-3	13-8	14-1	
	4-70	550	620	690	750	810	870	930	990	1040	1090	1140	1200	1240	1290	1340	1390	1480	1570	
19.2	7-3	7-10	8-4	8-9	9-2	9-6	9-10	10-2	10-6	10-9	11-1	11-4	11-7	11-9	12-0	12-3	12-5	12-10	13-3	
	5-00	580	660	730	800	870	930	990	1050	1110	1160	1220	1270	1320	1370	1420	1470	1570	1660	
	6-9	7-3	7-9	8-2	8-6	8-10	9-2	9-6	9-9	10-0	10-3	10-6	10-9	10-11	11-2	11-4	11-7	11-11	12-3	
	5-40	630	710	790	860	930	1000	1070	1130	1190	1250	1310	1370	1420	1480	1530	1590	1690	1790	

WISCONSIN ADMINISTRATIVE CODE

2x8	11-3	12-1	12-10	13-6	14-2	14-8	15-3	15-9	16-2	16-7	17-0	17-5	17-10	18-2	18-6	18-10	19-2	19-10	20-5
	430	500	560	630	680	740	790	850	900	950	980	1040	1090	1130	1170	1220	1260	1340	1420
	10-9	11-7	12-3	12-11	12-6	14-1	14-7	15-0	15-6	15-11	16-3	16-8	17-0	17-5	17-9	18-0	18-4	18-11	19-6
	450	520	590	650	720	770	830	880	940	990	1040	1090	1140	1180	1230	1270	1320	1400	1490
	10-2	11-0	11-8	12-3	12-10	13-4	13-10	14-3	14-8	15-1	15-6	15-10	16-2	16-8	16-10	17-2	17-5	18-0	18-6
	470	550	620	690	750	810	870	930	990	1040	1090	1140	1200	1240	1290	1340	1390	1480	1570
	500	580	660	730	800	870	930	990	1050	1110	1160	1220	1270	1320	1370	1420	1470	1570	1660
	8-11	9-7	10-2	10-9	11-3	11-8	12-1	12-6	12-10	12-6	13-2	13-8	14-2	14-5	14-8	15-0	15-3	15-9	16-2
	540	630	710	790	860	930	1000	1070	1130	1190	1250	1310	1370	1420	1480	1530	1590	1690	1790
	14-4	15-5	16-5	17-3	18-0	18-8	19-5	20-1	20-8	21-2	21-8	22-3	22-9	23-2	23-8	24-1	24-6	25-3	26-0
430	500	560	630	680	740	780	850	900	950	990	1040	1090	1130	1170	1220	1260	1340	1420	
2x10	13-8	14-9	15-8	16-6	17-3	17-11	18-7	19-2	19-9	20-3	20-9	21-3	21-9	22-2	22-7	23-0	23-5	24-2	24-10
	450	520	590	650	720	770	830	880	940	990	1040	1090	1140	1180	1230	1270	1320	1400	1490
	13-0	14-0	14-11	15-3	16-5	17-0	17-8	18-3	18-9	19-3	19-9	20-2	20-8	21-1	21-6	21-10	22-3	22-11	23-8
	470	550	620	690	750	810	870	930	990	1040	1090	1140	1200	1240	1290	1340	1390	1480	1570
	12-3	13-2	14-0	14-9	15-5	16-0	16-7	17-2	17-8	18-1	18-7	19-0	19-5	19-10	20-2	20-7	20-11	21-7	22-3
	500	580	660	730	800	870	930	990	1050	1110	1160	1220	1270	1320	1370	1420	1470	1570	1660
	11-4	12-3	13-0	13-8	14-4	14-11	15-5	15-11	16-5	16-10	17-3	17-8	18-0	18-5	18-9	19-1	19-5	20-1	20-8
	540	630	710	790	860	930	1000	1070	1130	1190	1250	1310	1370	1420	1480	1530	1590	1690	1790

Note: The required extreme fiber stress in bending, "F<sub>b</sub>", in pounds per square inch is shown below each span.

**TABLE J-4**  
**CEILING JOISTS**  
20 Lbs. Per Sq. Ft. Live Load  
(Limited attic storage where development of future rooms is not possible)  
(Crywall Ceiling)

**DESIGN CRITERIA:**  
Deflection - For 20 lbs. per sq. ft. live load.  
Limited to span in inches divided by 240.  
Strength - live load of 20 lbs. per sq. ft. plus dead load of 10 lbs. per sq. ft. determines required floor stress value.

JOIST SIZE SPACING (IN)	Modulus of Elasticity, "E", in 1,000,000 psi																			
	0.4	0.5	0.6	0.7	0.8	0.9	1.0	1.1	1.2	1.3	1.4	1.5	1.6	1.7	1.8	1.9	2.0	2.2	2.4	
12.0	6-2	6-8	7-1	7-6	7-10	8-1	8-5	8-8	8-11	9-2	9-5	9-8	9-10	10-0	10-3	10-5	10-7	10-11	11-2	
	5-11	6-5	6-9	7-2	7-6	7-9	8-1	8-4	8-7	8-9	9-0	9-3	9-5	9-7	9-9	10-0	10-2	10-6	10-9	
	5-8	6-1	6-5	6-9	7-1	7-5	7-8	7-11	8-1	8-4	8-7	8-9	8-11	9-1	9-4	9-6	9-8	9-11	10-3	
	5-4	5-9	6-1	6-5	6-8	6-11	7-2	7-5	7-8	7-10	8-1	8-2	8-5	8-7	8-9	8-11	9-1	9-4	9-8	
	4-11	5-4	5-8	5-11	6-2	6-5	6-8	6-11	7-1	7-3	7-6	7-8	7-10	8-0	8-1	8-3	8-5	8-8	8-11	
12.0	9-0	10-5	11-2	11-9	12-3	12-9	13-3	13-8	14-1	14-5	14-9	15-2	15-6	15-9	16-4	16-8	17-2	17-8	18-0	
	8-4	9-0	9-6	10-2	10-8	11-2	11-7	12-0	12-5	12-9	13-1	13-5	13-9	14-1	14-4	14-7	15-2	15-7	16-1	
	8-4	9-0	9-6	10-0	10-6	10-11	11-4	11-8	12-0	12-4	12-8	13-11	13-3	13-6	13-9	14-0	14-3	14-8	15-2	
	8-4	9-0	9-6	10-0	10-6	10-11	11-4	11-8	12-0	12-4	12-8	13-11	13-3	13-6	13-9	14-0	14-3	14-8	15-2	
	7-9	8-4	8-10	8-4	8-9	9-9	10-2	10-6	10-10	11-2	11-5	11-9	12-0	12-3	12-6	12-9	13-0	13-3	13-8	
19.2	6-2	6-8	7-1	7-6	7-10	8-1	8-5	8-8	8-11	9-2	9-5	9-8	9-10	10-0	10-3	10-5	10-7	10-11	11-2	
	5-11	6-5	6-9	7-2	7-6	7-9	8-1	8-4	8-7	8-9	9-0	9-3	9-5	9-7	9-9	10-0	10-2	10-6	10-9	
	5-8	6-1	6-5	6-9	7-1	7-5	7-8	7-11	8-1	8-4	8-7	8-9	8-11	9-1	9-4	9-6	9-8	9-11	10-3	
	5-4	5-9	6-1	6-5	6-8	6-11	7-2	7-5	7-8	7-10	8-1	8-2	8-5	8-7	8-9	8-11	9-1	9-4	9-8	
	4-11	5-4	5-8	5-11	6-2	6-5	6-8	6-11	7-1	7-3	7-6	7-8	7-10	8-0	8-1	8-3	8-5	8-8	8-11	
24.0	9-0	10-5	11-2	11-9	12-3	12-9	13-3	13-8	14-1	14-5	14-9	15-2	15-6	15-9	16-4	16-8	17-2	17-8	18-0	
	8-4	9-0	9-6	10-2	10-8	11-2	11-7	12-0	12-5	12-9	13-1	13-5	13-9	14-1	14-4	14-7	15-2	15-7	16-1	
	8-4	9-0	9-6	10-0	10-6	10-11	11-4	11-8	12-0	12-4	12-8	13-11	13-3	13-6	13-9	14-0	14-3	14-8	15-2	
	8-4	9-0	9-6	10-0	10-6	10-11	11-4	11-8	12-0	12-4	12-8	13-11	13-3	13-6	13-9	14-0	14-3	14-8	15-2	
	7-9	8-4	8-10	8-4	8-9	9-9	10-2	10-6	10-10	11-2	11-5	11-9	12-0	12-3	12-6	12-9	13-0	13-3	13-8	



WISCONSIN ADMINISTRATIVE CODE

12.0	12-10 560	13-10 660	14-8 740	15-6 820	16-2 900	16-10 970	17-5 1040	18-0 1110	18-6 1170	19-0 1240	19-6 1300	19-11 1360	20-5 1420	20-10 1480	21-2 1540	21-7 1600	21-11 1650	22-8 1760	23-4 1860
13.7	12-3 590	13-3 690	14-1 770	14-10 860	15-6 940	16-1 1010	16-8 1090	17-2 1160	17-9 1230	18-2 1300	18-8 1360	19-1 1420	19-6 1490	19-11 1550	20-3 1610	20-8 1670	21-0 1730	21-8 1840	22-4 1950
16.0	11-8 620	12-7 720	13-4 810	14-1 900	14-8 990	15-3 1070	15-10 1140	16-4 1220	16-10 1290	17-3 1360	17-9 1430	18-2 1500	18-6 1570	18-11 1630	19-3 1690	19-7 1760	19-11 1820	20-7 1940	21-2 2050
19.2	11-0 660	11-10 770	12-7 870	13-3 960	13-10 1050	14-5 1130	14-11 1220	15-5 1300	15-10 1370	16-3 1450	16-8 1520	17-1 1590	17-5 1660	17-9 1730	18-2 1800	18-5 1870	18-9 1930	19-5 2060	21-0 2180
24.0	10-2 710	11-0 830	11-8 930	12-3 1030	12-10 1130	13-4 1220	13-10 1310	14-3 1400	14-8 1480	15-1 1560	15-6 1640	15-10 1720	16-2 1790	16-6 1870	16-10 1940	17-2 2010	17-6 2080	18-0 2220	18-6 2350
12.0	16-5 560	17-8 660	18-8 740	19-9 820	20-8 900	21-6 970	22-3 1040	22-11 1110	23-8 1170	24-3 1240	24-10 1300	24-5 1360	25-0 1420	25-5 1480	27-1 1540	27-6 1600	28-0 1650	28-11 1760	29-9 1860
13.7	15-8 590	16-11 690	17-11 770	18-11 860	19-9 940	20-6 1010	21-3 1090	21-11 1160	22-7 1230	23-3 1300	23-9 1360	24-4 1420	24-10 1490	25-5 1550	26-10 1610	26-10 1670	26-10 1730	27-8 1840	28-6 1950
16.0	14-11 620	16-0 720	17-0 810	17-11 900	18-9 990	19-6 1070	20-2 1140	20-10 1220	21-6 1290	22-1 1360	22-7 1430	23-2 1500	23-8 1570	24-1 1630	24-7 1690	25-0 1760	25-5 1820	26-3 1940	27-1 2050
19.2	14-0 660	15-1 770	16-0 870	16-11 960	17-8 1050	18-4 1130	19-0 1220	19-9 1300	20-7 1370	20-9 1450	21-3 1520	21-8 1590	22-3 1660	22-8 1730	23-2 1800	23-7 1870	23-11 1930	24-9 2060	25-5 2180
24.0	13-0 710	14-0 830	14-11 930	15-8 1030	16-5 1130	17-0 1220	17-8 1310	18-3 1400	18-9 1480	19-3 1560	19-9 1640	20-2 1720	20-8 1790	21-1 1870	21-6 1940	21-10 2010	22-3 2080	22-11 2220	23-8 2350

Note: The required extreme fiber stress in bending, "F<sub>b</sub>", in pounds per square inch is shown below each span.

**TABLE J-5  
CEILING JOISTS**  
10 Lbs. Per Sq. Ft. Live Load  
(Plaster Ceiling)

**DESIGN CRITERIA:**  
Deflection - For 10 lbs. per sq. ft. live load.  
Limited to span in inches divided by 360.  
Strength - live load of 10 lbs. per sq. ft. plus  
dead load of 5 lbs. per sq. ft. determines  
required fiber stress value.

JOIST SIZE SPACING (IN)		Modulus of Elasticity, "E", in 1,000,000 psi																									
		1.0	1.1	1.2	1.3	1.4	1.5	1.6	1.7	1.8	1.9	2.0	2.2	2.4													
12.0	6-10	7.4	7-10	8-3	8-7	8-11	9-3	9-7	9-10	10-1	10-4	10-7	10-10	11-1	11-3	11-6	11-8	12-1	12-5								
	3-6	400	450	500	540	590	630	670	710	750	790	830	860	900	930	970	1000	1070	1130								
	13.7	6-6	7-0	7-6	7-10	8-3	8-7	8-10	9-2	9-5	9-8	9-11	10-2	10-4	10-7	10-9	11-0	11-2	11-5	11-10							
		3-6	410	470	520	570	610	660	700	740	780	820	860	900	940	970	1010	1050	1110	1180							
		6-2	380	440	490	550	600	650	690	740	780	830	870	910	950	990	1030	1080	1170	1240							
16.0	5-10	6-3	6-8	7-0	7-4	7-8	7-11	8-2	8-5	8-8	8-10	9-1	9-3	9-5	9-8	9-10	10-0	10-4	10-7								
	4-0	460	520	580	630	680	740	790	830	880	920	970	1010	1050	1090	1130	1170	1250	1320								
	5-5	5-10	6-2	6-6	6-10	7-1	7-4	7-7	7-10	8-0	8-3	8-5	8-7	8-9	8-11	9-1	9-3	9-7	9-10								
18.2	4-0	490	560	630	680	740	790	850	900	950	990	1040	1080	1130	1170	1220	1260	1340	1420								
	10-9	11-7	12-3	12-11	13-6	14-1	14-7	15-0	15-6	15-11	16-3	16-8	17-0	17-4	17-8	18-0	18-4	18-11	19-6								
	3-6	400	450	500	540	590	630	670	710	750	790	830	860	900	930	970	1000	1070	1130								
13.7	10-3	11-1	11-9	12-4	13-11	13-5	13-11	14-4	14-9	15-2	15-7	15-11	16-3	16-7	16-11	17-3	17-6	18-1	18-8								
	3-6	410	470	520	570	610	660	700	740	780	830	860	900	940	970	1010	1050	1110	1180								
	9-9	10-6	11-2	11-9	12-3	12-9	13-3	13-8	14-1	14-5	14-9	15-2	15-6	15-9	16-1	16-4	16-8	17-2	17-8								
16.0	3-6	480	440	490	550	600	650	690	740	780	830	870	910	950	980	1030	1080	1170	1240								
	9-2	400	460	520	580	630	690	740	790	830	880	920	970	1010	1050	1090	1130	1170	1250								
	19.2	400	460	520	580	630	690	740	790	830	880	920	970	1010	1050	1090	1130	1170	1250								
24.0	8-6	9-2	9-9	10-3	10-9	11-2	11-7	11-11	12-3	12-7	13-11	13-3	13-6	13-9	14-1	14-4	14-7	15-0	15-6								
	4-0	450	500	560	630	680	740	790	850	900	950	1000	1040	1080	1130	1170	1220	1260	1340								
	10-9	11-7	12-3	12-11	13-6	14-1	14-7	15-0	15-6	15-11	16-3	16-8	17-0	17-4	17-8	18-0	18-4	18-11	19-6								

WISCONSIN ADMINISTRATIVE CODE

12.0	14.2	15.3	15-2	17.0	17-10	18-6	18-2	19-10	20-5	20-11	21-5	21-11	22-5	22-11	23-4	23-9	24-2	24-11	25-8
	340	400	450	500	540	580	630	670	710	750	790	830	880	900	930	970	1000	1070	1130
13.7	13-6	14-7	15-6	16-3	17-0	17-9	18-4	18-11	19-6	20-0	20-6	21-0	21-5	21-11	22-4	22-9	23-1	23-10	24-7
	360	410	470	520	570	610	660	700	740	780	820	860	900	940	970	1010	1050	1110	1180
2x8	12-10	13-10	14-8	15-6	16-2	16-10	17-5	18-0	18-6	19-0	19-6	19-11	20-5	20-10	21-2	21-7	21-11	22-8	23-4
	380	440	490	550	600	650	690	740	780	830	870	910	950	990	1030	1060	1100	1170	1240
19.2	12-1	13.0	13-10	14.7	15-3	15-10	16-5	16-11	17-5	17-11	18-4	18-9	19-2	19-7	19-11	20-4	20-8	21-4	21-11
	400	460	520	580	630	690	740	790	830	880	920	970	1010	1050	1090	1130	1170	1250	1320
24.0	11-3	12-1	12-10	13-6	14-2	14-8	15-3	15-9	16-2	16-7	17-0	17-5	17-10	18-2	18-6	18-10	19-2	19-10	20-5
	430	500	560	630	680	740	790	850	900	950	990	1040	1090	1130	1170	1220	1260	1340	1420
12.0	18-0	19-5	20-8	21-9	22-9	23-8	24-6	25-3	26-0	26-9	27-5	28-0	28-7	29-2	29-9	30-4	30-10	31-10	32-9
	340	400	450	500	540	590	630	670	710	750	790	830	880	900	930	970	1000	1070	1130
13.7	17-3	18-7	19-9	20-9	21-9	22-7	23-5	24-2	24-10	25-7	26-2	26-10	27-5	27-11	28-6	29-0	29-6	30-5	31-4
	360	410	470	520	570	610	660	700	740	780	820	860	900	940	970	1010	1050	1110	1180
2x10	16-5	17-8	18-9	19-9	20-8	21-6	22-3	22-11	23-8	24-3	24-10	25-5	26-0	26-6	27-1	27-6	28-0	28-11	29-9
	380	440	490	550	600	650	690	740	780	830	870	910	950	990	1030	1060	1100	1170	1240
19.2	15-5	16-7	17-8	18-7	19-5	20-2	20-11	21-7	22-3	22-10	23-5	23-11	24-6	25-0	25-5	25-11	26-4	27-3	28-0
	400	460	520	580	630	680	740	790	830	880	920	970	1010	1050	1090	1130	1170	1250	1320
24.0	14-4	15-5	16-6	17-3	18-0	18-9	19-5	20-1	20-8	21-2	21-9	22-3	22-9	23-2	23-8	24-1	24-6	25-3	26-0
	430	500	560	630	680	740	790	850	900	950	990	1040	1090	1130	1170	1220	1260	1340	1420

Note: The required extreme fiber stress in bending, "F<sub>b</sub>" in pounds per square inch is shown below each span.

**TABLE J-6  
CEILING JOISTS**  
10 Lbs. Per Sq. Ft. Live Load  
(No attic storage and roof slope not steeper than 3 in 12)  
(Drywall Ceiling)

**DESIGN CRITERIA:**  
Deflection For 10 lbs. per sq. ft. live load,  
Limited to span in inches divided by 240.  
Sizing based on 10 lbs. per sq. ft. plus  
dead load for 5 lbs. per sq. ft. determine  
required fiber stress value.

JOIST SIZE SPACING (IN)	Modulus of Elasticity, "E", in 1,000,000 psi																			
	0.4	0.5	0.6	0.7	0.8	0.9	1.0	1.1	1.2	1.3	1.4	1.5	1.6	1.7	1.8	1.9	2.0	2.2	2.4	
12.0	7-10	8-5	8-11	9-5	9-10	10-3	10-7	10-11	11-3	11-7	11-10	12-2	12-5	12-8	12-11	13-2	13-4	13-9	14-2	
	450	520	590	650	710	770	830	880	930	980	1030	1080	1130	1180	1220	1270	1310	1400	1480	
13.7	7-6	8-1	8-7	9-0	9-5	9-9	10-2	10-6	10-9	11-1	11-4	11-7	11-10	12-1	12-4	12-7	12-9	13-2	13-7	
	470	540	610	680	740	800	860	920	970	1030	1080	1130	1180	1230	1280	1320	1370	1460	1550	
16.0	7-1	7-8	8-1	8-7	8-11	9-4	9-8	9-11	10-3	10-6	10-9	11-0	11-3	11-6	11-9	12-11	12-2	12-6	12-11	
	480	570	650	720	780	850	910	970	1030	1080	1140	1190	1240	1290	1340	1390	1440	1540	1630	
19.2	6-8	7-2	7-8	8-1	8-5	8-9	9-1	9-4	9-8	9-11	10-2	10-4	10-7	10-10	11-0	11-2	11-5	11-9	12-2	
	520	610	690	760	830	900	970	1030	1080	1150	1210	1270	1320	1380	1430	1480	1530	1630	1730	
24.0	6-2	6-8	7-1	7-6	7-10	8-1	8-5	8-8	8-11	9-2	9-5	9-8	9-10	10-0	10-3	10-5	10-7	10-11	11-2	
	560	660	740	820	900	970	1040	1110	1170	1240	1300	1360	1420	1480	1540	1600	1650	1760	1860	
12.0	12-3	13-3	14-1	14-9	15-6	16-1	16-8	17-2	17-8	18-2	18-8	19-1	19-6	19-11	20-3	20-8	21-0	21-9	22-4	
	450	520	590	650	710	770	830	880	930	980	1030	1080	1130	1180	1220	1270	1310	1400	1480	
13.7	11-9	12-8	13-5	14-2	14-9	15-5	15-11	16-5	16-11	17-5	17-10	18-3	18-8	19-0	19-5	19-9	20-1	20-9	21-4	
	470	540	610	680	740	800	860	920	970	1030	1080	1130	1180	1230	1280	1320	1370	1460	1550	
16.0	11-2	12-0	12-9	13-5	14-1	14-7	15-2	15-7	16-1	16-6	16-11	17-4	17-8	18-1	18-5	18-9	19-1	19-8	20-3	
	490	570	650	720	780	850	910	970	1030	1080	1140	1190	1240	1290	1340	1390	1440	1540	1630	
19.2	10-6	11-4	12-0	12-8	13-3	13-9	14-3	14-8	15-2	15-7	15-11	16-4	16-8	17-0	17-4	17-8	17-11	18-6	19-1	
	520	610	690	760	830	900	970	1030	1080	1150	1210	1270	1320	1380	1430	1480	1530	1630	1730	
24.0	9-9	10-6	11-2	11-9	12-3	12-9	13-3	13-8	14-1	14-5	14-9	15-2	15-6	15-9	16-1	16-4	16-8	17-2	17-8	
	560	660	740	820	900	970	1040	1110	1170	1240	1300	1360	1420	1480	1540	1600	1650	1760	1860	

WISCONSIN ADMINISTRATIVE CODE

12.0	16-2	17-5	18-6	19-6	20-5	21-2	21-11	22-3	23-4	24-0	24-7	25-2	25-8	26-2	26-9	27-2	27-8	28-7	29-5
	450	520	590	650	710	770	830	880	930	980	1030	1080	1130	1180	1220	1270	1310	1400	1480
13.7	15-6	16-3	17-9	18-8	19-6	20-3	21-0	21-8	22-4	22-11	23-6	24-0	24-7	25-1	25-7	26-0	26-6	27-4	28-1
	470	540	610	680	740	800	860	920	970	1030	1080	1130	1180	1230	1280	1320	1370	1460	1550
2x8	14-8	15-10	16-10	17-9	18-6	19-3	19-11	20-7	21-2	21-9	22-4	22-10	22-4	23-10	24-3	24-8	25-2	25-11	26-9
	480	570	650	720	780	850	910	970	1030	1080	1140	1190	1240	1290	1340	1390	1440	1540	1630
19.2	13-10	14-11	15-10	16-8	17-5	18-2	18-9	19-5	19-11	20-6	21-0	21-6	21-11	22-5	22-10	23-3	23-8	24-5	25-2
	520	610	690	760	830	900	970	1030	1090	1150	1210	1270	1330	1380	1430	1480	1530	1630	1730
24.0	12-10	13-10	14-8	15-6	16-2	16-10	17-5	18-0	18-6	19-0	19-6	19-11	20-5	20-10	21-2	21-7	21-11	22-8	23-4
	560	660	740	820	900	970	1040	1110	1170	1240	1300	1360	1420	1480	1540	1600	1650	1760	1860
12.0	20-8	22-3	23-3	24-10	25-0	27-1	28-0	28-11	29-9	30-7	31-4	32-1	32-9	33-5	34-1	34-8	35-4	36-5	37-6
	450	520	590	650	710	770	830	880	930	980	1030	1080	1130	1180	1220	1270	1310	1400	1480
13.7	19-9	21-3	22-7	23-9	24-10	25-10	26-10	27-8	28-6	29-3	30-0	30-8	31-4	32-0	32-7	33-2	33-8	34-10	35-10
	470	540	610	680	740	800	860	920	970	1030	1080	1130	1180	1230	1280	1320	1370	1460	1550
16.0	18-9	20-2	21-6	22-7	23-8	24-7	25-5	26-3	27-1	27-9	28-5	29-2	29-9	30-5	31-0	31-6	32-1	33-1	34-1
	490	570	650	720	780	850	910	970	1030	1080	1140	1190	1240	1290	1340	1390	1440	1540	1630
19.2	17-8	19-0	20-2	21-3	22-3	23-2	23-11	24-9	25-5	26-2	26-10	27-6	28-0	28-7	29-2	29-8	30-2	31-2	32-1
	520	610	690	760	830	900	970	1030	1090	1150	1210	1270	1330	1380	1430	1480	1530	1630	1730
24.0	16-5	17-8	18-9	19-9	20-8	21-6	22-3	22-11	23-8	24-3	24-10	25-5	26-0	26-6	27-1	27-6	28-0	28-11	29-9
	560	660	740	820	900	970	1040	1110	1170	1240	1300	1360	1420	1480	1540	1600	1650	1760	1860

Note: The required extreme fiber stress in bending, "F<sub>b</sub>", in pounds per square inch is shown below each span.

**TABLE R-2**  
**FLAT OR SLOPED RAFTERS**  
**Supporting Drywall Ceiling**  
 (Flat roof or cathedral ceiling with no attic space)  
 Live Load - 30 lb. per sq. ft.  
 Use in Zone 2

**DESIGN CRITERIA:**  
 Strength - 15 lbs. per sq. ft. dead load plus 30  
 lbs. per sq. ft. live load determines required  
 fiber stress.  
 Deflection - For 30 lbs. per sq. ft. live load,  
 Limited to span in inches divided by 240.

RAFTER SIZE SPACING (IN)	Extreme Fiber Stress in Bending, "F <sub>b</sub> " (psi).											
	300	400	500	600	700	800	900	1000	1100	1200	1300	
2x6	12.0	5-10 0.13	6-8 0.19	7-6 0.27	8-2 0.36	8-10 0.45	9-6 0.55	10-0 0.66	10-7 0.77	11-1 0.89	11-7 1.01	12-1 1.14
	13.7	5-5 0.12	6-3 0.18	7-0 0.25	7-8 0.33	8-3 0.42	8-10 0.52	9-5 0.61	9-11 0.72	10-5 0.83	10-10 0.95	11-3 1.07
	16.0	5-0 0.11	5-10 0.17	6-6 0.24	7-1 0.31	7-8 0.39	8-2 0.48	8-8 0.57	9-2 0.67	9-7 0.77	10-0 0.88	10-5 0.99
	19.2	4-7 0.10	5-4 0.15	5-11 0.22	6-6 0.28	7-0 0.36	7-6 0.44	7-11 0.52	8-4 0.61	8-9 0.70	9-2 0.80	9-6 0.90
	24.0	4-1 0.09	4-9 0.14	5-4 0.19	5-10 0.25	6-3 0.32	6-8 0.39	7-1 0.46	7-6 0.54	7-10 0.63	8-2 0.72	8-6 0.81
2x8	12.0	7-8 0.13	8-10 0.19	9-10 0.27	10-10 0.36	11-8 0.45	12-6 0.55	13-3 0.66	13-11 0.77	14-8 0.89	15-3 1.01	15-11 1.14
	13.7	7-2 0.12	8-3 0.18	9-3 0.25	10-1 0.33	10-11 0.42	11-8 0.52	12-5 0.61	13-1 0.72	13-8 0.83	14-4 0.95	14-11 1.07
	16.0	6-7 0.11	7-8 0.17	8-7 0.24	9-4 0.31	10-1 0.39	10-10 0.48	11-6 0.57	12-1 0.67	12-8 0.77	13-3 0.88	13-9 0.99
	19.2	6-1 0.10	7-0 0.15	7-10 0.22	8-7 0.28	9-3 0.36	9-10 0.44	10-6 0.52	11-0 0.61	11-7 0.70	12-1 0.80	12-7 0.90
	24.0	5-5 0.09	6-3 0.14	7-0 0.19	7-8 0.25	8-3 0.32	8-10 0.39	9-4 0.46	9-10 0.54	10-4 0.63	10-10 0.72	11-3 0.81

Register, March, 1992, No. 436

2x10	12.0	9-9 0.13	11-3 0.19	12-7 0.27	13-9 0.36	14-11 0.45	15-11 0.55	16-11 0.66	17-10 0.77	18-8 0.89	19-6 1.01	20-4 1.14
	13.7	9-1 0.12	10-6 0.18	11-9 0.25	12-11 0.33	13-11 0.42	14-11 0.52	15-10 0.61	16-8 0.72	17-6 0.83	18-3 0.95	19-0 1.07
	16.0	8-5 0.11	9-9 0.17	10-11 0.24	11-11 0.31	12-11 0.39	13-9 0.48	14-8 0.57	15-5 0.67	16-2 0.77	16-11 0.88	17-7 0.99
	19.2	7-8 0.10	8-11 0.15	9-11 0.22	10-11 0.28	11-9 0.36	12-7 0.44	13-4 0.52	14-1 0.61	14-9 0.70	15-5 0.80	16-1 0.90
	24.0	6-11 0.09	8-0 0.14	8-11 0.19	9-9 0.25	10-6 0.32	11-3 0.39	11-11 0.46	12-7 0.54	13-2 0.63	13-9 0.72	14-4 0.81
2x12	12.0	11-10 0.13	13-8 0.19	15-4 0.27	16-9 0.36	18-1 0.45	19-4 0.55	20-6 0.66	21-8 0.77	22-8 0.89	23-9 1.01	24-8 1.14
	13.7	11-1 0.12	12-10 0.18	14-4 0.25	15-8 0.33	16-11 0.42	18-1 0.52	19-3 0.61	20-3 0.72	21-3 0.83	22-2 0.95	23-1 1.07
	16.0	10-3 0.11	11-10 0.17	13-3 0.24	14-6 0.31	15-8 0.39	16-9 0.48	17-9 0.57	18-9 0.67	19-8 0.77	20-6 0.88	21-5 0.99
	19.2	9-5 0.10	10-10 0.15	12-1 0.22	13-3 0.28	14-4 0.36	15-4 0.44	16-3 0.52	17-1 0.61	17-11 0.70	18-9 0.80	19-6 0.90
	24.0	8-5 0.09	9-8 0.14	10-10 0.19	11-10 0.25	12-10 0.32	13-8 0.39	14-6 0.46	15-4 0.54	16-1 0.63	16-9 0.72	17-5 0.81

Note: The required modulus of elasticity, "E", in 1,000,000 pounds per square inch is shown below each span.

TABLE R-2 (cont.)

RAFTERS: Spans are measured along the horizontal projection and loads are considered as applied on the horizontal projection.

Extreme Fiber Stress in Bending, "F <sub>b</sub> " (psi).											RAFTER SPACING SIZE (IN)	
1400	1500	1600	1700	1800	1900	2000	2100	2200	2400	2700	(IN)	(IN)
12-6 1.28	13-0 1.41	13-5 1.56	13-10 1.71	14-2 1.86	14-7 2.02	15-0 2.18	15-4 2.34	15-8 2.51			12.0	2x6
11-9 1.19	12-2 1.32	12-6 1.46	12-11 1.60	13-3 1.74	13-8 1.89	14-0 2.04	14-4 2.19	14-8 2.35			13.7	
10-10 1.10	11-3 1.22	11-7 1.35	11-11 1.48	12-4 1.61	12-8 1.75	13-0 1.89	13-3 2.03	13-7 2.18	14-2 2.48		16.0	
9-11 1.01	10-3 1.12	10-7 1.23	10-11 1.35	11-3 1.47	11-6 1.59	11-10 1.72	12-2 1.85	12-5 1.99	13-0 2.26		19.2	
8-10 0.90	9-2 1.00	9-6 1.10	9-9 1.21	10-0 1.31	10-4 1.43	10-7 1.54	10-10 1.66	11-1 1.78	11-7 2.02	12-4 2.41	24.0	
16-6 1.28	17-1 1.41	17-8 1.56	18-2 1.71	18-9 1.86	19-3 2.02	19-9 2.18	20-3 2.34	20-8 2.51			12.0	
15-5 1.19	16-0 1.32	16-6 1.46	17-0 1.60	17-6 1.74	18-0 1.89	18-5 2.04	18-11 2.19	19-4 2.35			13.7	
14-4 1.10	14-10 1.22	15-3 1.35	15-9 1.48	16-3 1.61	16-8 1.75	17-1 1.89	17-6 2.03	17-11 2.18	18-9 2.48		16.0	
13-1 1.01	13-6 1.12	13-11 1.23	14-5 1.35	14-10 1.47	15-2 1.59	15-7 1.72	16-0 1.85	16-4 1.99	17-1 2.26		19.2	
11-8 0.90	12-1 1.00	12-6 1.10	12-10 1.21	13-3 1.31	13-7 1.43	13-11 1.54	14-4 1.66	14-8 1.78	15-3 2.02	16-3 2.41	24.0	



21-1 1.28	21-10 1.41	22-6 1.56	23-3 1.71	23-11 1.86	24-6 2.02	25-2 2.18	25-10 2.34	26-5 2.51				12.0	2x10	
19-8 1.19	20-5 1.32	21-1 1.46	21-9 1.60	22-4 1.74	22-11 1.89	23-7 2.04	24-2 2.19	24-8 2.35				13.7		
18-3 1.10	18-11 1.22	19-6 1.35	20-1 1.48	20-8 1.61	21-3 1.75	21-10 1.89	22-4 2.03	22-10 2.18	23-11 2.48			16.0		
16-8 1.01	17-3 1.12	17-10 1.23	18-4 1.35	18-11 1.47	19-5 1.59	19-11 1.72	20-5 1.85	20-10 1.99	21-10 2.26			19.2		
14-11 0.90	15-5 1.00	15-11 1.10	16-5 1.21	16-11 1.31	17-4 1.43	17-10 1.54	18-3 1.66	18-8 1.78	19-6 2.02	20-8 2.41		24.0		
25-7 1.28	26-6 1.41	27-5 1.56	28-3 1.71	29-1 1.86	29-10 2.02	30-7 2.18	31-4 2.34	32-1 2.51				12.0		2x12
24-0 1.19	24-10 1.32	25-7 1.46	26-5 1.60	27-2 1.74	27-11 1.89	28-8 2.04	29-4 2.19	30-0 2.35				13.7		
22-2 1.10	23-0 1.22	23-9 1.35	24-5 1.48	25-2 1.61	25-10 1.75	26-6 1.89	27-2 2.03	27-10 2.18	29-1 2.48			16.0		
20-3 1.07	21-0 1.12	21-8 1.23	22-4 1.35	23-0 1.47	23-7 1.59	24-2 1.72	24-10 1.85	25-5 1.99	26-6 2.26			19.2		
18-1 0.90	18-9 1.00	19-4 1.10	20-0 1.21	20-6 1.31	21-1 1.43	21-8 1.54	22-2 1.66	22-8 1.78	23-9 2.02	25-2 2.41		24.0		

Note: The required modulus of elasticity, "E", in 1,000,000 pounds per square inch is shown below each span.

**TABLE R-3  
FLAT OR SLOPED RAFTERS  
Supporting Drywall Ceiling**  
(Flat roof or cathedral ceiling with no attic space)

Live Load - 40 lb. per sq. ft.

Use in Zone 1

**DESIGN CRITERIA:**

Strength - 15 lbs. per sq. ft. dead load plus 40 lbs. per sq. ft. live load determines required fiber stress.

Deflection - For 40 lbs. per sq. ft. live load. Limited to span in inches divided by 240.

RAFTER SIZE SPACING (IN) (IN)		Extreme Fiber Stress in Bending, "F <sub>b</sub> " (psi).										
		300	400	500	600	700	800	900	1000	1100	1200	1300
2x6	12.0	5-3 0.12	6-1 0.19	6-9 0.27	7-5 0.35	8-0 0.44	8-7 0.54	9-1 0.65	9-7 0.76	10-0 0.88	10-6 1.00	10-11 1.13
	13.7	4-11 0.12	5-8 0.18	6-4 0.25	6-11 0.33	7-6 0.42	8-0 0.51	8-6 0.61	8-11 0.71	9-5 0.82	9-10 0.93	10-3 1.05
	16.0	4-6 0.11	5-3 0.17	5-10 0.23	6-5 0.31	6-11 0.39	7-5 0.47	7-10 0.56	8-3 0.66	8-8 0.76	9-1 0.86	9-5 0.98
	19.2	4-2 0.10	4-9 0.15	5-4 0.21	5-10 0.28	6-4 0.35	6-9 0.43	7-2 0.51	7-7 0.60	7-11 0.69	8-3 0.79	8-8 0.89
	24.0	3-8 0.09	4-3 0.14	4-9 0.19	5-3 0.25	5-8 0.31	6-1 0.38	6-5 0.46	6-9 0.54	7-1 0.62	7-5 0.71	7-9 0.80
2x8	12.0	6-11 0.12	8-0 0.19	8-11 0.27	9-9 0.35	10-7 0.44	11-3 0.54	12-0 0.65	12-7 0.76	13-3 0.88	13-10 1.00	14-5 1.13
	13.7	6-6 0.12	7-6 0.18	8-4 0.25	9-2 0.33	9-11 0.42	10-7 0.51	11-2 0.61	11-10 0.71	12-5 0.82	12-11 0.93	13-6 1.05
	16.0	6-0 0.11	6-11 0.17	7-9 0.23	8-6 0.31	9-2 0.39	9-9 0.47	10-4 0.56	10-11 0.66	11-6 0.76	12-0 0.86	12-6 0.98
	19.2	5-6 0.10	6-4 0.15	7-1 0.21	7-9 0.28	8-4 0.35	8-11 0.43	9-6 0.51	10-0 0.60	10-6 0.69	10-11 0.79	11-5 0.89
	24.0	4-11 0.09	5-8 0.14	6-4 0.19	6-11 0.25	7-6 0.31	8-0 0.38	8-6 0.46	8-11 0.54	9-4 0.62	9-9 0.71	10-2 0.80

2x10	12.0	8-10 0.12	10-2 0.19	11-5 0.27	12-6 0.35	13-6 0.44	14-5 0.54	15-3 0.65	16-1 0.76	16-11 0.88	17-8 1.00	18-4 1.13
	13.7	8-3 0.12	9-6 0.18	10-8 0.25	11-8 0.33	12-7 0.42	13-6 0.51	14-3 0.61	15-1 0.71	15-10 0.82	16-6 0.93	17-2 1.05
	16.0	7-8 0.11	8-10 0.17	9-10 0.23	10-10 0.31	11-8 0.39	12-6 0.47	13-3 0.56	13-11 0.66	14-8 0.76	15-3 0.86	15-11 0.98
	19.2	7-0 0.10	8-1 0.15	9-0 0.21	9-10 0.28	10-8 0.35	11-5 0.43	12-1 0.51	12-9 0.60	13-4 0.69	13-11 0.79	14-6 0.89
	24.0	6-3 0.09	7-2 0.14	8-1 0.19	8-10 0.25	9-6 0.31	10-2 0.38	10-10 0.46	11-5 0.54	11-11 0.62	12-6 0.71	13-0 0.80
2x12	12.0	10-9 0.12	12-5 0.19	13-10 0.27	15-2 0.35	16-5 0.44	17-6 0.54	18-7 0.65	19-7 0.76	20-6 0.88	21-5 1.00	22-4 1.13
	13.7	10-0 0.12	11-7 0.18	12-11 0.25	14-2 0.33	15-4 0.42	16-5 0.51	17-5 0.61	18-4 0.71	19-3 0.82	20-1 0.93	20-11 1.05
	16.0	9-3 0.11	10-9 0.17	12-0 0.23	13-2 0.31	14-2 0.39	15-2 0.47	16-1 0.56	17-0 0.66	17-9 0.76	18-7 0.86	19-4 0.98
	19.2	8-6 0.10	9-10 0.15	10-11 0.21	12-0 0.28	12-11 0.35	13-10 0.43	14-8 0.51	15-6 0.60	16-3 0.69	17-0 0.79	17-8 0.89
	24.0	7-7 0.09	8-9 0.14	9-10 0.19	10-9 0.25	11-7 0.31	12-5 0.38	13-2 0.46	13-10 0.54	14-6 0.62	15-2 0.71	15-9 0.80

Note: The required modulus of elasticity, "E", in 1,000,000 pounds per square inch is shown below each span.

TABLE R-3 (cont.)

RAFTERS: Spans are measured along the horizontal projection and loads are considered as applied on the horizontal projection.

Extreme Fiber Stress in Bending, "F <sub>b</sub> " (psi).											RAFTER SPACING SIZE (IN) (IN)
1400	1500	1600	1700	1800	1900	2000	2100	2200	2400	2700	
11-4 1.26	11-9 1.40	12-1 1.54	12-6 1.68	12-10 1.83	13-2 1.99	13-6 2.15	13-10 2.31	14-2 2.48			12.0
10-7 1.18	11-0 1.31	11-4 1.44	11-8 1.57	12-0 1.72	12-4 1.86	12-8 2.01	13-0 2.16	13-3 2.32			13.7
9-10 1.09	10-2 1.21	10-6 1.33	10-10 1.46	11-1 1.59	11-5 1.72	11-9 1.86	12-0 2.00	12-4 2.15	12-10 2.45		16.0
8-11 0.99	9-3 1.10	9-7 1.22	9-10 1.33	10-2 1.45	10-5 1.57	10-8 1.70	11-0 1.83	11-3 1.96	11-9 2.23		19.2
8-0 0.89	8-3 0.99	8-7 1.09	8-10 1.19	9-1 1.30	9-4 1.41	9-7 1.52	9-10 1.63	10-0 1.75	10-6 2.00	11-1 2.38	24.0
14-11 1.26	15-5 1.40	16-0 1.54	16-5 1.68	16-11 1.83	17-5 1.99	17-10 2.15	18-3 2.31	18-9 2.48			12.0
14-0 1.18	14-6 1.31	14-11 1.44	15-5 1.57	15-10 1.72	16-3 1.86	16-8 2.01	17-1 2.16	17-6 2.32			13.7
12-11 1.09	13-5 1.21	13-10 1.33	14-3 1.46	14-8 1.59	15-1 1.72	15-5 1.86	15-10 2.00	16-3 2.15	16-11 2.45		16.0
11-10 0.99	12-3 1.10	12-7 1.22	13-0 1.33	13-6 1.45	13-9 1.57	14-1 1.70	14-6 1.83	14-10 1.96	15-5 2.23		19.2
10-7 0.89	10-11 0.99	11-3 1.09	11-8 1.19	12-0 1.30	12-4 1.41	12-7 1.52	12-11 1.63	13-3 1.75	13-10 2.00	14-8 2.38	24.0

19-1 1.26	19-9 1.40	20-4 1.54	21-0 1.68	21-7 1.83	22-2 1.99	22-9 2.15	23-4 2.31	23-11 2.48			12.0	2x10
17-10 1.18	18-5 1.31	19-1 1.44	19-8 1.57	20-2 1.72	20-9 1.86	21-4 2.01	21-10 2.16	22-4 2.32			13.7	
16-6 1.09	17-1 1.21	17-8 1.33	18-2 1.46	18-9 1.59	19-3 1.72	19-9 1.86	20-2 2.00	20-8 2.15	21-7 2.45		16.0	
15-1 0.99	15-7 1.10	16-1 1.22	16-7 1.33	17-1 1.45	17-7 1.57	18-0 1.70	18-5 1.83	18-11 1.96	19-9 2.23		19.2	
13-6 0.89	13-11 0.99	14-5 1.09	14-10 1.19	15-3 1.30	15-8 1.41	16-1 1.52	16-6 1.63	16-11 1.75	17-8 2.00	18-9 2.38	24.0	
23-2 1.26	24-0 1.40	24-9 1.54	25-6 1.68	26-3 1.83	27-0 1.99	27-8 2.15	28-5 2.31	29-1 2.48			12.0	2x12
21-8 1.18	22-5 1.31	23-2 1.44	23-11 1.57	24-7 1.72	25-3 1.86	25-11 2.01	26-7 2.16	27-2 2.32			13.7	
20-1 1.09	20-9 1.21	21-5 1.33	22-1 1.46	22-9 1.59	23-5 1.72	24-0 1.86	24-7 2.00	25-2 2.15	26-3 2.45		16.0	
18-4 0.99	19-0 1.10	19-7 1.22	20-2 1.33	20-9 1.45	21-4 1.57	21-11 1.70	22-5 1.83	23-0 1.96	24-0 2.23		19.2	
16-5 0.89	17-0 0.99	17-6 1.09	18-1 1.19	18-7 1.30	19-1 1.41	19-7 1.52	20-1 1.63	20-6 1.75	21-5 2.00	22-9 2.38	24.0	

Note: The required modulus of elasticity, "E", in 1,000,000 pounds per square inch is shown below each span.

**TABLE R-5**  
**FLAT OR SLOPED RAFTERS**  
 Supporting Plaster Ceiling  
 (Flat roof or cathedral ceiling with no attic space)  
 Live Load - 30 lb. per sq. ft.

**DESIGN CRITERIA:**

Strength - 15 lbs. per sq. ft. dead load plus 30 lbs. per sq. ft. live load determines required fiber stress.

Deflection - For 30 lbs. per sq. ft. live load. Limited to Span in inches divided by 360.

Use in Zone 2

RAFTER SIZE SPACING (IN) (IN)		Extreme Fiber Stress in Bending, "F <sub>b</sub> " (psi).									
		300	400	500	600	700	890	900	1000	1100	1200
2x6	12.0	5-10	6-8	7-6	8-2	8-10	9-6	10-0	10-7	11-1	11-7
		0.19	0.29	0.41	0.54	0.68	0.83	0.99	1.15	1.33	1.52
	13.7	5-5	6-3	7-0	7-8	8-3	8-10	9-5	9-11	10-5	10-10
		0.18	0.27	0.38	0.50	0.63	0.77	0.92	1.08	1.25	1.42
	16.0	5-0	5-10	6-6	7-1	7-8	8-2	8-8	9-2	9-7	10-0
0.16		0.25	0.35	0.46	0.59	0.72	0.85	1.00	1.15	1.31	
19.2	4-7	5-4	5-11	6-6	7-0	7-6	7-11	8-4	8-9	9-2	
	0.15	0.23	0.32	0.42	0.53	0.65	0.78	0.91	1.05	1.20	
24.0	4-1	4-9	5-4	5-10	6-3	6-8	7-1	7-6	7-10	8-2	
		0.13	0.21	0.29	0.38	0.48	0.58	0.70	0.82	0.94	1.07
2x8	12.0	7-8	8-10	9-10	10-10	11-8	12-6	13-3	13-11	14-8	15-3
		0.19	0.29	0.41	0.54	0.68	0.83	0.99	1.15	1.33	1.52
	13.7	7-2	8-3	9-3	10-1	10-11	11-8	12-5	13-1	13-8	14-4
		0.18	0.27	0.38	0.50	0.63	0.77	0.92	1.08	1.25	1.42
	16.0	6-7	7-8	8-7	9-4	10-1	10-10	11-6	12-1	12-8	13-3
0.16		0.25	0.35	0.46	0.59	0.72	0.85	1.00	1.15	1.31	
19.2	6-1	7-0	7-10	8-7	9-3	9-10	10-6	11-0	11-7	12-1	
	0.15	0.23	0.32	0.42	0.53	0.65	0.78	0.91	1.05	1.20	
24.0	5-5	6-3	7-0	7-8	8-3	8-10	9-4	9-10	10-4	10-10	
		0.13	0.21	0.29	0.38	0.48	0.58	0.70	0.82	0.94	1.07

2x10	12.0	9-9 0.19	11-3 0.29	12-7 0.41	13-9 0.54	14-11 0.68	15-11 0.83	16-11 0.99	17-10 1.15	18-8 1.33	19-6 1.52
	13.7	9-1 0.18	10-6 0.27	11-9 0.38	12-11 0.50	13-11 0.63	14-11 0.77	15-10 0.92	16-8 1.08	17-6 1.25	18-3 1.42
	16.0	8-5 0.16	9-9 0.25	10-11 0.35	11-11 0.46	12-11 0.59	13-9 0.72	14-8 0.85	15-5 1.00	16-2 1.15	16-11 1.31
	19.2	7-8 0.15	8-11 0.23	9-11 0.32	10-11 0.42	11-9 0.53	12-7 0.65	13-4 0.78	14-1 0.91	14-9 1.05	15-5 1.20
	24.0	6-11 0.13	8-0 0.21	8-11 0.29	9-9 0.38	10-6 0.48	11-3 0.58	11-11 0.70	12-7 0.82	13-2 0.94	13-9 1.07
	12.0	11-10 0.19	13-8 0.29	15-4 0.41	16-9 0.54	18-1 0.68	19-4 0.83	20-6 0.99	21-8 1.15	22-8 1.33	23-9 1.52
2x12	13.7	11-1 0.18	12-10 0.27	14-4 0.38	15-8 0.50	16-11 0.63	18-1 0.77	19-3 0.92	20-3 1.08	21-3 1.25	22-2 1.42
	16.0	10-3 0.16	11-10 0.25	13-3 0.35	14-6 0.46	15-8 0.59	16-9 0.72	17-9 0.85	18-9 1.00	19-8 1.15	20-6 1.31
	19.2	9-5 0.15	10-10 0.23	12-1 0.32	13-3 0.42	14-4 0.53	15-4 0.65	16-3 0.78	17-1 0.91	17-11 1.05	18-9 1.20
	24.0	8-5 0.13	9-8 0.21	10-10 0.29	11-10 0.38	12-10 0.48	13-8 0.58	14-6 0.70	15-4 0.82	16-1 0.94	16-9 1.07

Note: The required modulus of elasticity, "E", in 1,000,000 pounds per square inch is shown below each span.

TABLE R-5 (cont.)

RAFTERS: Spans are measured along the horizontal projection and loads are considered as applied on the horizontal projection.

Extreme Fiber Stress in Bending, "F <sub>b</sub> " (psi).									RAFTER SPACING SIZE (IN) (IN)	
1300	1400	1500	1600	1700	1800	1900	2000	2100		
12-1 1.71	12-6 1.91	13-0 2.12	13-5 2.34	13-10 2.56					12.0	2x6
11-3 1.60	11-9 1.79	12-2 1.98	12-6 2.19	12-11 2.39					13.7	
10-5 1.48	10-10 1.66	11-3 1.84	11-7 2.02	11-11 2.22	12-4 2.41				16.0	
9-6 1.35	9-11 1.51	10-3 1.68	10-7 1.85	10-11 2.02	11-3 2.20	11-6 2.39	11-10 2.58		19.2	
8-6 1.21	8-10 1.35	9-2 1.50	9-6 1.65	9-9 1.81	10-0 1.97	10-4 2.14	10-7 2.31	10-10 2.48	24.0	
15-11 1.71	16-6 1.91	17-1 2.12	17-8 2.34	18-2 2.56					12.0	
14-11 1.60	15-5 1.79	16-0 1.98	16-6 2.19	17-0 2.39					13.7	
13-9 1.48	14-4 1.66	14-10 1.84	15-3 2.02	15-9 2.22	16-3 2.41				16.0	
12-7 1.35	13-1 1.51	13-6 1.68	13-11 1.85	14-5 2.02	14-10 2.20	15-2 2.39	15-7 2.58		19.2	
11-3 1.21	11-8 1.35	12-1 1.50	12-6 1.65	12-10 1.81	13-3 1.97	13-7 2.14	13-11 2.31	14-4 2.48	24.0	



20-4 1.71	21-1 1.91	21-10 2.12	22-6 2.34	23-3 2.56					12.0	2x10
19-0 1.60	19-8 1.79	20-5 1.98	21-1 2.19	21-9 2.39					13.7	
17-7 1.48	18-3 1.66	18-11 1.84	19-6 2.02	20-1 2.22	20-8 2.41				16.0	
16-1 1.35	16-8 1.51	17-3 1.68	17-10 1.85	18-4 2.02	18-11 2.20	19-5 2.39	19-11 2.58		19.2	
14-4 1.21	14-11 1.35	15-5 1.50	15-11 1.65	16-5 1.81	16-11 1.97	17-4 2.14	17-10 2.31	18-3 2.48	24.0	
24-8 1.71	25-7 1.91	26-6 2.12	27-5 2.34	28-3 2.56					12.0	2x12
23-1 1.60	24-0 1.79	24-10 1.98	25-7 2.19	26-5 2.39					13.7	
21-5 1.48	22-2 1.66	23-0 1.84	23-9 2.02	24-5 2.22	25-2 2.41				16.0	
19-6 1.35	20-3 1.51	21-0 1.68	21-8 1.85	22-4 2.02	23-0 2.20	23-7 2.39	24-2 2.58		19.2	
17-5 1.21	18-1 1.35	18-9 1.50	19-4 1.65	20-0 1.81	20-6 1.97	21-1 2.14	21-8 2.31	22-2 2.48	24.0	

Note: The required modulus of elasticity, "E", in 1,000,000 pounds per square inch is shown below each span.

**TABLE R-6**  
**FLAT OR SLOPED RAFTERS**  
**Supporting Plaster Ceiling**  
 (Flat roof or cathedral ceiling with no attic space)  
 Live Load - 40 lb. per sq. ft.

**DESIGN CRITERIA:**  
 Strength - 15 lbs. per sq. ft. dead load plus 40  
 lbs. per sq. ft. live load determines required  
 fiber stress.  
 Deflection - For 40 lbs. per sq. ft. live load,  
 Limited to span in inches divided by 360.

Use in Zone 1

RAFTER SIZE SPACING (IN) (IN)		Extreme Fiber Stress in Bending, "F <sub>b</sub> " (psi).									
		300	400	500	600	700	800	900	1000	1100	1200
2x6	12.0	5-3 0.19	6-1 0.29	6-9 0.40	7-5 0.53	8-0 0.67	8-7 0.82	9-1 0.97	9-7 1.14	10-0 1.31	10-6 1.50
	13.7	4-11 0.18	5-8 0.27	6-4 0.38	6-11 0.50	7-6 0.62	8-0 0.76	8-6 0.91	8-11 1.07	9-5 1.23	9-10 1.40
	16.0	4-6 0.16	5-3 0.25	5-10 0.35	6-5 0.46	6-11 0.58	7-5 0.71	7-10 0.84	8-3 0.99	8-8 1.14	9-1 1.30
	19.2	4-2 0.15	4-9 0.23	5-4 0.32	5-10 0.42	6-4 0.53	6-9 0.64	7-2 0.77	7-7 0.90	7-11 1.04	8-3 1.18
	24.0	3-8 0.13	4-3 0.20	4-9 0.28	5-3 0.37	5-8 0.47	6-1 0.58	6-5 0.69	6-9 0.81	7-1 0.93	7-5 1.06
2x8	12.0	6-11 0.19	8-0 0.29	8-11 0.40	9-9 0.53	10-7 0.67	11-3 0.82	12-0 0.97	12-7 1.14	13-3 1.31	13-10 1.50
	13.7	6-6 0.18	7-6 0.27	8-4 0.38	9-2 0.50	9-11 0.62	10-7 0.76	11-2 0.91	11-10 1.07	12-5 1.23	12-11 1.40
	16.0	6-0 0.16	6-11 0.25	7-9 0.35	8-6 0.46	9-2 0.58	9-9 0.71	10-4 0.84	10-11 0.99	11-6 1.14	12-0 1.30
	19.2	5-6 0.15	6-4 0.23	7-1 0.32	7-9 0.42	8-4 0.53	8-11 0.64	9-6 0.77	10-0 0.90	10-6 1.04	10-11 1.18
	24.0	4-11 0.13	5-8 0.20	6-4 0.28	6-11 0.37	7-6 0.47	8-0 0.58	8-6 0.69	8-11 0.81	9-4 0.93	9-9 1.06

2x10	12.0	8-10 0.19	10-2 0.29	11-5 0.40	12-6 0.53	13-6 0.67	14-5 0.82	15-3 0.97	16-1 1.14	16-11 1.31	17-8 1.50
	13.7	8-3 0.18	9-6 0.27	10-8 0.38	11-8 0.50	12-7 0.62	13-6 0.76	14-3 0.91	15-1 1.07	15-10 1.23	16-6 1.40
	16.0	7-8 0.16	8-10 0.25	9-10 0.35	10-10 0.46	11-8 0.58	12-6 0.71	13-3 0.84	13-11 0.99	14-8 1.14	15-3 1.30
	19.2	7-0 0.15	8-1 0.23	9-0 0.32	9-10 0.42	10-8 0.53	11-5 0.64	12-1 0.77	12-9 0.90	13-4 1.04	13-11 1.18
	24.0	6-3 0.13	7-2 0.20	8-1 0.28	8-10 0.37	9-6 0.47	10-2 0.58	10-10 0.69	11-5 0.81	11-11 0.93	12-6 1.06
	2x12	12.0	10-9 0.19	12-5 0.29	13-10 0.40	15-2 0.53	16-5 0.67	17-6 0.82	18-7 0.97	19-7 1.14	20-6 1.31
13.7		10-0 0.18	11-7 0.27	12-11 0.38	14-2 0.50	15-4 0.62	16-5 0.76	17-5 0.91	18-4 1.07	19-3 1.23	20-1 1.40
16.0		9-3 0.16	10-9 0.25	12-0 0.35	13-2 0.46	14-2 0.58	15-2 0.71	16-1 0.84	17-0 0.99	17-9 1.14	18-7 1.30
19.2		8-6 0.15	9-10 0.23	10-11 0.32	12-0 0.42	12-11 0.53	13-10 0.64	14-8 0.77	15-6 0.90	16-3 1.04	17-0 1.18
24.0		7-7 0.13	8-9 0.20	9-10 0.28	10-9 0.37	11-7 0.47	12-5 0.58	13-2 0.69	13-10 0.81	14-6 0.93	15-2 1.06

Note: The required modulus of elasticity, "E", in 1,000,000 pounds per square inch is shown below each span.

TABLE R-6 (cont.)

RAFTERS: Spans are measured along the horizontal projection and loads are considered as applied on the horizontal projection.

Extreme Fiber Stress in Bending, "F <sub>b</sub> " (psi).									RAFTER SPACING SIZE (IN) (IN)
1300	1400	1500	1600	1700	1800	1900	2000	2100	
10-11 1.69	11-4 1.89	11-9 2.09	12-1 2.31	12-6 2.53					12.0
10-3 1.58	10-7 1.77	11-0 1.96	11-4 2.16	11-8 2.36	12-0 2.57				13.7
9-5 1.46	9-10 1.63	10-2 1.81	10-6 2.00	10-10 2.19	11-1 2.38	11-5 2.58			16.0
8-8 1.34	8-11 1.49	9-3 1.65	9-7 1.82	9-10 2.00	10-2 2.18	10-5 2.36	10-8 2.55		19.2
7-9 1.19	8-0 1.33	8-3 1.48	8-7 1.63	8-10 1.79	9-1 1.95	9-4 2.11	9-7 2.28	9-10 2.45	24.0
14-5 1.69	14-11 1.89	15-5 2.09	16-0 2.31	16-5 2.53					12.0
13-6 1.58	14-0 1.77	14-6 1.96	14-11 2.16	15-5 2.36	15-10 2.57				13.7
12-6 1.46	12-11 1.63	13-5 1.81	13-10 2.00	14-3 2.19	14-8 2.38	15-1 2.58			16.0
11-5 1.34	11-10 1.49	12-3 1.65	12-7 1.82	13-0 2.00	13-5 2.18	13-9 2.36	14-1 2.55		19.2
10-2 1.19	10-7 1.33	10-11 1.48	11-3 1.63	11-8 1.79	12-0 1.95	12-4 2.11	12-7 2.28	12-11 2.45	24.0

18-4 1.69	19-1 1.89	19-9 2.09	20-4 2.31	21-0 2.53					12.0	2x10
17-2 1.88	17-10 1.77	18-5 1.96	19-1 2.16	19-8 2.36	20-2 2.57				13.7	
15-11 1.46	16-6 1.63	17-1 1.81	17-8 2.00	18-2 2.19	18-9 2.38	19-3 2.58			16.0	
14-6 1.34	15-1 1.49	15-7 1.65	16-1 1.82	16-7 2.00	17-1 2.18	17-7 2.36	18-0 2.55		19.2	
13-0 1.19	13-6 1.33	13-11 1.48	14-5 1.63	14-10 1.79	15-3 1.95	15-8 2.11	16-1 2.28	16-6 2.45	24.0	
22-4 1.69	23-2 1.89	24-0 2.09	24-9 2.31	25-6 2.53					12.0	
20-11 1.58	21-8 1.77	22-5 1.96	23-2 2.16	23-11 2.36	24-7 2.57				13.7	
19-4 1.46	20-1 1.63	20-9 1.81	21-5 2.00	22-1 2.19	22-9 2.38	23-5 2.58			16.0	
17-8 1.34	18-4 1.49	19-0 1.65	19-7 1.82	20-2 2.00	20-9 2.18	21-4 2.36	21-11 2.55		19.2	
15-9 1.19	16-5 1.33	17-0 1.48	17-6 1.63	18-1 1.79	18-7 1.95	19-1 2.11	19-7 2.28	20-1 2.45	24.0	

Note: The required modulus of elasticity, "E", in 1,000,000 pounds per square inch is shown below each span.

TABLE R-8  
FLAT OR LOW SLOPE RAFTERS

No Ceiling Load  
Slope 3 in 12 or less  
Live Load - 30 lb. per sq. ft.  
Use in Zone 2

DESIGN CRITERIA:

Strength - 10 lbs. per sq. ft. dead load plus 30 lbs. per sq. ft. live load determines required fiber stress.

Deflection - For 30 lbs. per sq. ft. live load. Limited to span in inches divided by 240.

RAFTER SIZE (IN)	SPACING (IN)	Extreme Fiber Stress In Bending, "F <sub>b</sub> " (psi).										
		300	400	500	600	700	800	900	1000	1100	1200	1300
2x6	12.0	6-2 0.15	7-1 0.23	7-11 0.32	8-8 0.43	9-5 0.54	10-0 0.66	10-8 0.78	11-3 0.92	11-9 1.06	12-4 1.21	12-10 1.36
	13.7	5-9 0.14	6-8 0.22	7-5 0.30	8-2 0.40	8-9 0.50	9-5 0.61	10-0 0.73	10-6 0.86	11-0 0.99	11-6 1.13	12-0 1.27
	16.0	5-4 0.13	6-2 0.20	6-11 0.28	7-6 0.37	8-2 0.47	8-8 0.57	9-3 0.68	9-9 0.80	10-2 0.92	10-8 1.05	11-1 1.18
	19.2	4-10 0.12	5-7 0.18	6-3 0.26	6-11 0.34	7-5 0.43	7-11 0.52	8-5 0.62	8-11 0.73	9-4 0.84	9-9 0.95	10-1 1.08
	24.0	4-4 0.11	5-0 0.16	5-7 0.23	6-2 0.30	6-8 0.38	7-1 0.46	7-6 0.55	7-11 0.65	8-4 0.75	8-8 0.85	9-1 0.96
	2x8	12.0	8-1 0.15	9-4 0.23	10-6 0.32	11-6 0.43	12-5 0.54	13-3 0.66	14-0 0.78	14-10 0.92	15-6 1.06	16-3 1.21
13.7		7-7 0.14	8-9 0.22	9-9 0.30	10-9 0.40	11-7 0.50	12-5 0.61	13-2 0.73	13-10 0.86	14-6 0.99	15-2 1.13	15-9 1.27
16.0		7-0 0.13	8-1 0.20	9-1 0.28	9-11 0.37	10-9 0.47	11-6 0.57	12-2 0.68	12-10 0.80	13-5 0.92	14-0 1.05	14-7 1.18
19.2		6-5 0.12	7-5 0.18	8-3 0.26	9-1 0.34	9-9 0.43	10-6 0.52	11-1 0.62	11-8 0.73	12-3 0.84	12-10 0.95	13-4 1.08
24.0		5-9 0.11	6-7 0.16	7-5 0.23	8-1 0.30	8-9 0.38	9-4 0.46	9-11 0.55	10-6 0.65	11-0 0.75	11-6 0.85	11-11 0.96

2x10	12.0	10-4 0.15	11-11 0.23	13-4 0.32	14-8 0.43	15-10 0.54	16-11 0.66	17-11 0.78	18-11 0.92	19-10 1.06	20-8 1.21	21-6 1.36
	13.7	9-8 0.14	11-2 0.22	12-6 0.30	13-8 0.40	14-9 0.50	15-10 0.61	16-9 0.73	17-8 0.86	18-6 0.99	19-4 1.13	20-2 1.27
	16.0	8-11 0.13	10-4 0.20	11-7 0.28	12-8 0.37	13-8 0.47	14-8 0.57	15-6 0.68	16-4 0.80	17-2 0.92	17-11 1.05	18-8 1.18
	19.2	8-2 0.12	9-5 0.18	10-7 0.26	11-7 0.34	12-6 0.43	13-4 0.52	14-2 0.62	14-11 0.73	15-8 0.84	16-4 0.95	17-0 1.08
	24.0	7-4 0.11	8-5 0.16	9-5 0.23	10-4 0.30	11-2 0.38	11-11 0.46	12-8 0.55	13-4 0.65	14-0 0.75	14-8 0.85	15-3 0.96
2x12	12.0	12-7 0.15	14-6 0.23	16-3 0.32	17-9 0.43	19-3 0.54	20-6 0.66	21-9 0.78	23-0 0.92	24-1 1.06	25-2 1.21	26-2 1.36
	13.7	11-9 0.14	13-7 0.22	15-2 0.30	16-8 0.40	18-0 0.50	19-3 0.61	20-5 0.73	21-6 0.86	22-6 0.99	23-6 1.13	24-6 1.27
	16.0	10-11 0.13	12-7 0.20	14-1 0.28	15-5 0.37	16-8 0.47	17-9 0.57	18-10 0.68	19-11 0.80	20-10 0.92	21-9 1.05	22-8 1.18
	19.2	9-11 0.12	11-6 0.18	12-10 0.26	14-1 0.34	15-2 0.43	16-3 0.52	17-3 0.62	18-2 0.73	19-0 0.84	19-11 0.95	20-8 1.08
	24.0	8-11 0.11	10-3 0.16	11-6 0.23	12-7 0.30	13-7 0.38	14-6 0.46	15-5 0.55	16-3 0.65	17-0 0.75	17-9 0.85	18-6 0.96

Note: The required modulus of elasticity, "E", in 1,000,000 pounds per square inch is shown below each span.

TABLE R-8 (cont.)

RAFTERS: Spans are measured along the horizontal projection and loads are considered as applied on the horizontal projection.

Extreme Fiber Stress in Bending, "F <sub>b</sub> " (psi).										RAFTER SPACING SIZE (IN)	
1400	1500	1600	1700	1800	1900	2000	2100	2200	2400		
13-3 1.52	13-9 1.69	14-2 1.86	14-8 2.04	15-1 2.22	15-6 2.41	15-11 2.60					12.0
12-5 1.42	12-10 1.58	13-3 1.74	13-8 1.90	14-1 2.08	14-6 2.25	14-10 2.43					13.7
11-6 1.32	11-11 1.46	12-4 1.61	12-8 1.76	13-1 1.92	13-5 2.08	13-9 2.25	14-1 2.42	14-5 2.60			16.0
10-6 1.20	10-10 1.33	11-3 1.47	11-7 1.61	11-11 1.75	12-3 1.90	12-7 2.05	12-10 2.21	13-2 2.37			19.2
9-5 1.08	9-9 1.19	10-0 1.31	10-4 1.44	10-8 1.57	10-11 1.70	11-3 1.84	11-6 1.98	11-9 2.12	12-4 2.41		24.0
17-6 1.52	18-2 1.69	18-9 1.86	19-4 2.04	19-10 2.22	20-5 2.41	20-11 2.60					12.0
16-5 1.42	16-11 1.58	17-6 1.74	18-1 1.90	18-7 2.08	19-1 2.25	19-7 2.43					13.7
15-2 1.32	15-8 1.46	16-3 1.61	16-9 1.76	17-2 1.92	17-8 2.08	18-2 2.25	18-7 2.42	19-0 2.60			16.0
13-10 1.20	14-4 1.33	14-10 1.47	15-3 1.61	15-8 1.75	16-2 1.90	16-7 2.05	16-11 2.21	17-4 2.37			19.2
12-5 1.08	12-10 1.19	13-3 1.31	13-8 1.44	14-0 1.57	14-5 1.70	14-10 1.84	15-2 1.98	15-6 2.12	16-3 2.41		24.0



22-4 1.52	23-2 1.69	23-11 1.86	24-7 2.04	25-4 2.22	26-0 2.41	26-8 2.60				12.0	2x10
20-11 1.42	21-8 1.58	22-4 1.74	23-0 1.90	23-8 2.08	24-4 2.25	25-0 2.43				13.7	
19-4 1.32	20-0 1.46	20-8 1.61	21-4 1.76	21-11 1.92	22-6 2.08	23-2 2.25	23-8 2.42	24-3 2.60		16.0	
17-8 1.20	18-3 1.33	18-11 1.47	19-6 1.61	20-0 1.75	20-7 1.90	21-1 2.05	21-8 2.21	22-2 2.37		19.2	
15-10 1.08	16-4 1.19	16-11 1.31	17-5 1.44	17-11 1.57	18-5 1.70	18-11 1.84	19-4 1.98	19-10 2.12	20-8 2.41	24.0	
27-2 1.52	28-2 1.69	29-1 1.86	29-11 2.04	30-10 2.22	31-8 2.41	32-6 2.60				12.0	2x12
25-5 1.42	26-4 1.58	27-2 1.74	28-0 1.90	28-10 2.08	29-7 2.25	30-5 2.43				13.7	
23-6 1.32	24-4 1.46	25-2 1.61	25-11 1.76	26-8 1.92	27-5 2.08	28-2 2.25	28-10 2.42	29-6 2.60		16.0	
21-6 1.20	22-3 1.33	23-0 1.47	23-8 1.61	24-4 1.75	25-0 1.90	25-8 2.05	26-4 2.21	26-11 2.37		19.2	
19-3 1.08	19-11 1.19	20-6 1.31	21-2 1.44	21-9 1.57	22-5 1.70	23-0 1.84	23-6 1.98	24-1 2.12	25-2 2.41	24.0	

Note: The required modulus of elasticity, "E", in 1,000,000 pounds per square inch is shown below each span.

TABLE R-9  
FLAT OR LOW SLOPE RAFTERS

No Ceiling Load  
Slope 3 in 12 or less  
Live Load - 40 lb. per sq. ft.  
Use in Zone 1

DESIGN CRITERIA:

Strength - 10 lbs. per sq. ft. dead load plus 40  
lbs. per sq. ft. live load determines required  
fiber stress.

Deflection - For 40 lbs. per sq. ft. live load.  
Limited to span in inches divided by 240.

RAFTER SIZE SPACING (IN) (IN)		Extreme Fiber Stress in Bending, "F <sub>b</sub> " (psi).										
		300	400	500	600	700	800	900	1000	1100	1200	1300
2x6	12.0	5-6 0.14	6-4 0.22	7-1 0.31	7-9 0.41	8-5 0.51	9-0 0.63	9-6 0.75	10-0 0.88	10-6 1.01	11-0 1.15	11-5 1.30
	13.7	5-2 0.13	5-11 0.21	6-8 0.29	7-3 0.38	7-10 0.48	8-5 0.59	8-11 0.70	9-5 0.82	9-10 0.95	10-3 1.08	10-9 1.22
	16.0	4-9 0.12	5-6 0.19	6-2 0.27	6-9 0.35	7-3 0.44	7-9 0.54	8-3 0.65	8-8 0.76	9-1 0.88	9-6 1.00	9-11 1.12
	19.2	4-4 0.11	5-0 0.18	5-7 0.24	6-2 0.32	6-8 0.41	7-1 0.50	7-6 0.59	7-11 0.69	8-4 0.80	8-8 0.91	9-1 1.03
	24.0	3-11 0.10	4-6 0.16	5-0 0.22	5-6 0.29	5-11 0.36	6-4 0.44	6-9 0.53	7-1 0.62	7-5 0.71	7-9 0.81	8-1 0.92
2x8	12.0	7-3 0.14	8-4 0.22	9-4 0.31	10-3 0.41	11-1 0.51	11-10 0.63	12-7 0.75	13-3 0.88	13-11 1.01	14-6 1.15	15-1 1.30
	13.7	6-9 0.13	7-10 0.21	8-9 0.29	9-7 0.38	10-4 0.48	11-1 0.59	11-9 0.70	12-5 0.82	13-0 0.95	13-7 1.08	14-1 1.22
	16.0	6-3 0.12	7-3 0.19	8-1 0.27	8-11 0.35	9-7 0.44	10-3 0.54	10-11 0.65	11-6 0.76	12-0 0.88	12-7 1.00	13-1 1.12
	19.2	5-9 0.11	6-7 0.18	7-5 0.24	8-1 0.32	8-9 0.41	9-4 0.50	9-11 0.59	10-6 0.69	11-0 0.80	11-6 0.91	11-11 1.03
	24.0	5-2 0.10	5-11 0.16	6-7 0.22	7-3 0.29	7-10 0.36	8-4 0.44	8-11 0.53	9-4 0.62	9-10 0.71	10-3 0.81	10-8 0.92

2x10	12.0	9-3 0.14	10-8 0.22	11-11 0.31	13-1 0.41	14-2 0.51	15-1 0.63	16-0 0.75	16-11 0.88	17-9 1.01	18-6 1.15	19-3 1.30
	13.7	8-8 0.13	10-0 0.21	11-2 0.29	12-3 0.38	13-3 0.48	14-2 0.59	15-0 0.70	15-10 0.82	16-7 0.95	17-4 1.08	18-0 1.22
	16.0	8-0 0.12	9-3 0.19	10-4 0.27	11-4 0.35	12-3 0.44	13-1 0.54	13-11 0.65	14-8 0.76	15-4 0.88	16-0 1.00	16-8 1.12
	19.2	7-4 0.11	8-5 0.18	9-5 0.24	10-4 0.32	11-2 0.41	11-11 0.50	12-8 0.59	13-4 0.69	14-0 0.80	14-8 0.91	15-3 1.03
	24.0	6-6 0.10	7-7 0.16	8-5 0.22	9-3 0.29	10-0 0.36	10-8 0.44	11-4 0.53	11-11 0.62	12-6 0.71	13-1 0.81	13-7 0.92
2x12	12.0	11-3 0.14	13-0 0.22	14-6 0.31	15-11 0.41	17-2 0.51	18-4 0.63	19-6 0.75	20-6 0.88	21-7 1.01	22-6 1.15	23-5 1.30
	13.7	10-6 0.13	12-2 0.21	13-7 0.29	14-11 0.38	16-1 0.48	17-2 0.59	18-3 0.70	19-3 0.82	20-2 0.95	21-1 1.08	21-11 1.22
	16.0	9-9 0.12	11-3 0.19	12-7 0.27	13-9 0.35	14-11 0.44	15-11 0.54	16-11 0.65	17-9 0.76	18-8 0.88	19-6 1.00	20-3 1.12
	19.2	8-11 0.11	10-3 0.18	11-6 0.24	12-7 0.32	13-7 0.41	14-6 0.50	15-5 0.59	16-3 0.69	17-0 0.80	17-9 0.91	18-6 1.03
	24.0	7-11 0.10	9-2 0.16	10-3 0.22	11-3 0.29	12-2 0.36	13-0 0.44	13-9 0.53	14-6 0.62	15-3 0.71	15-11 0.81	16-7 0.92

Note: The required modulus of elasticity, "E", in 1,000,000 pounds per square inch is shown below each span.

TABLE R-9 (cont.)

RAFTERS: Spans are measured along the horizontal projection and loads are considered as applied on the horizontal projection.

Extreme Fiber Stress in Bending, "F <sub>b</sub> " (psi).										RAFTER SPACING SIZE (IN) (IN)	
1400	1500	1600	1700	1800	1900	2000	2100	2200	2400		
11-11 1.45	12-4 1.61	12-8 1.77	13-1 1.94	13-6 2.12	13-10 2.30	14-2 2.48					12.0
11-1 1.36	11-6 1.51	11-11 1.66	12-3 1.82	12-7 1.98	12-11 2.15	13-3 2.32	13-7 2.49				13.7
10-3 1.26	10-8 1.39	11-0 1.54	11-4 1.68	11-8 1.83	12-0 1.99	12-4 2.15	12-7 2.31	12-11 2.48			16.0
9-5 1.15	9-9 1.27	10-0 1.40	10-4 1.54	10-8 1.67	10-11 1.81	11-3 1.96	11-6 2.11	11-9 2.26	12-4 2.58		19.2
8-5 1.03	8-8 1.14	9-0 1.25	9-3 1.37	9-6 1.50	9-9 1.62	10-0 1.75	10-3 1.89	10-6 2.02	11-0 2.30		24.0
15-8 1.45	16-3 1.61	16-9 1.77	17-3 1.94	17-9 2.12	18-3 2.30	18-9 2.48					12.0
14-8 1.36	15-2 1.51	15-8 1.66	16-2 1.82	16-7 1.98	17-1 2.15	17-6 2.32	17-11 2.49				13.7
13-7 1.26	14-0 1.39	14-6 1.54	14-11 1.68	15-5 1.83	15-10 1.99	16-3 2.15	16-7 2.31	17-0 2.48			16.0
12-5 1.15	12-10 1.27	13-3 1.40	13-8 1.54	14-0 1.67	14-5 1.81	14-10 1.96	15-2 2.11	15-6 2.26	16-3 2.58		19.2
11-1 1.03	11-6 1.14	11-10 1.25	12-2 1.37	12-7 1.50	12-11 1.62	13-3 1.75	13-7 1.89	13-11 2.02	14-6 2.30		24.0

20-0 1.45	20-8 1.61	21-4 1.77	22-0 1.94	22-8 2.12	23-3 2.30	23-11 2.48					12.0	2x10
18-8 1.36	19-4 1.51	20-0 1.66	20-7 1.82	21-2 1.98	21-9 2.15	22-4 2.32	22-11 2.49				13.7	
17-4 1.26	17-11 1.39	18-6 1.54	19-1 1.68	19-7 1.83	20-2 1.99	20-8 2.15	21-2 2.31	21-8 2.48			16.0	
15-10 1.15	16-4 1.27	16-11 1.40	17-5 1.54	17-11 1.67	18-5 1.81	18-11 1.96	19-4 2.11	19-10 2.26	20-8 2.58		19.2	
14-2 1.03	14-8 1.14	15-1 1.25	15-7 1.37	16-0 1.50	16-6 1.62	16-11 1.75	17-4 1.89	17-9 2.02	18-6 2.30		24.0	
24-4 1.45	25-2 1.61	26-0 1.77	26-9 1.94	27-7 2.12	28-4 2.30	29-1 2.48					12.0	2x12
22-9 1.36	23-6 1.51	24-4 1.66	25-1 1.82	25-9 1.98	26-6 2.15	27-2 2.32	27-10 2.49				13.7	
21-1 1.26	21-9 1.39	22-6 1.54	23-2 1.68	23-10 1.83	24-6 1.99	25-2 2.15	25-9 2.31	26-5 2.48			16.0	
19-3 1.15	19-11 1.27	20-6 1.40	21-2 1.54	21-9 1.67	22-5 1.81	23-0 1.96	23-6 2.11	24-1 2.26	25-2 2.58		19.2	
17-2 1.03	17-9 1.14	18-4 1.25	18-11 1.37	19-6 1.50	20-0 1.62	20-6 1.75	21-1 1.89	21-7 2.02	22-6 2.30		24.0	

Note: The required modulus of elasticity, "E", in 1,000,000 pounds per inch is shown below each span.

**TABLE R-11**  
**MEDIUM OR HIGH SLOPE RAFTERS**  
 No Ceiling Load  
 Slope over 3 in 12  
 Live Load - 30 lbs. per sq. ft.  
 (heavy roof covering)  
 Use in Zone 2

**DESIGN CRITERIA:**  
 Strength - 15 lbs. per sq. ft. dead load plus  
 30 lbs. per sq. ft. live load determines  
 required fiber stress.  
 Deflection - For 30 lbs. per sq. ft. live load.  
 Limited to span in inches divided by 180.

RAFTER SIZE SPACING (IN)		Extreme Fiber Stress in Bending, "F <sub>b</sub> " (psi).												
		200	300	400	500	600	700	800	900	1000	1100	1200	1300	
12.0	3-0	3-8	4-3	4-9	5-3	5-8	6-0	6-5	6-9	7-1	7-5	7-8	8-6	
		0-05	0-09	0-15	0-20	0-27	0-34	0-41	0-49	0-58	0-67	0-76	0-86	
		2-10	3-5	4-0	4-5	4-11	5-3	5-8	6-0	6-4	6-7	6-11	7-2	
	13.7	2-10	3-2	3-8	4-1	4-6	4-11	5-3	5-6	5-10	6-1	6-5	6-8	6-8
			0-05	0-09	0-14	0-19	0-25	0-32	0-39	0-46	0-54	0-62	0-71	0-80
			2-7	3-2	3-8	4-1	4-6	4-11	5-3	5-6	5-10	6-1	6-5	6-8
	15.0	2-7	3-2	3-8	4-1	4-6	4-11	5-3	5-6	5-10	6-1	6-5	6-8	6-8
			0-04	0-08	0-13	0-18	0-23	0-29	0-36	0-43	0-50	0-58	0-66	0-74
			2-5	2-11	3-4	3-9	4-1	4-5	4-9	5-1	5-4	5-7	5-10	6-1
	19.2	2-5	2-11	3-4	3-9	4-1	4-5	4-9	5-1	5-4	5-7	5-10	6-1	6-1
0-04			0-08	0-12	0-16	0-21	0-27	0-33	0-39	0-46	0-53	0-60	0-68	
2-2			2-7	3-0	3-4	3-8	4-0	4-3	4-6	4-9	5-0	5-3	5-5	
24.0	2-2	3-0	3-4	3-8	4-0	4-3	4-6	4-9	5-0	5-3	5-5	5-5	5-5	
		0-04	0-07	0-10	0-14	0-19	0-24	0-29	0-35	0-41	0-47	0-54	0-61	
		4-9	5-10	6-8	7-6	8-2	8-10	9-6	10-0	10-7	11-1	11-7	12-1	
12.0	4-9	5-10	6-8	7-6	8-2	8-10	9-6	10-0	10-7	11-1	11-7	12-1	12-1	
		0-05	0-09	0-15	0-20	0-27	0-34	0-41	0-49	0-58	0-67	0-76	0-86	
		4-5	5-5	6-3	7-0	7-8	8-3	8-10	9-5	9-11	10-5	10-10	11-3	
13.7	4-5	5-5	6-3	7-0	7-8	8-3	8-10	9-5	9-11	10-5	10-10	11-3	11-3	
		0-05	0-09	0-14	0-19	0-25	0-32	0-39	0-46	0-54	0-62	0-71	0-80	
		4-1	5-0	5-10	6-6	7-1	7-8	8-2	8-8	9-2	9-7	10-0	10-5	
16.0	4-1	5-0	5-10	6-6	7-1	7-8	8-2	8-8	9-2	9-7	10-0	10-5	10-5	
		0-04	0-08	0-13	0-18	0-23	0-29	0-36	0-43	0-50	0-58	0-66	0-74	
		3-9	4-7	5-4	5-11	6-6	7-0	7-6	7-11	8-4	8-9	9-2	9-6	
19.2	3-9	4-7	5-4	5-11	6-6	7-0	7-6	7-11	8-4	8-9	9-2	9-6	9-6	
		0-04	0-08	0-12	0-16	0-21	0-27	0-33	0-39	0-46	0-53	0-60	0-68	
		3-4	4-1	4-9	5-4	5-10	6-3	6-8	7-1	7-6	7-10	8-2	8-6	
24.0	3-4	4-1	4-9	5-4	5-10	6-3	6-8	7-1	7-6	7-10	8-2	8-6	8-6	
		0-04	0-07	0-10	0-14	0-19	0-24	0-29	0-35	0-41	0-47	0-54	0-61	

Appendix

2x8	12.0	6-3	7-8	8-10	9-10	10-10	11-8	12-6	13-3	13-11	14-8	15-3	15-11
		0.05	0.09	0.15	0.20	0.27	0.34	0.41	0.49	0.58	0.67	0.76	0.85
	13.7	5-10	7-2	8-3	9-3	10-1	10-11	11-8	12-5	13-1	13-8	14-4	14-11
		0.05	0.09	0.14	0.19	0.25	0.32	0.39	0.46	0.54	0.62	0.71	0.80
	16.0	5-5	6-7	7-8	8-7	9-4	10-1	10-10	11-6	12-1	12-8	13-3	13-9
	0.04	0.08	0.13	0.18	0.23	0.29	0.36	0.43	0.50	0.58	0.66	0.74	
	19.2	4-11	6-1	7-0	7-10	8-7	9-3	9-10	10-6	11-0	11-7	12-1	12-7
		0.04	0.08	0.12	0.16	0.21	0.27	0.33	0.39	0.46	0.53	0.60	0.68
	24.0	4-5	5-5	6-3	7-0	7-8	8-3	8-10	9-4	9-10	10-4	10-10	11-3
		0.04	0.07	0.10	0.14	0.19	0.24	0.29	0.35	0.41	0.47	0.54	0.61
	12.0	8-0	9-9	11-3	12-7	13-9	14-11	15-11	16-11	17-10	18-8	19-6	20-4
		0.05	0.09	0.15	0.20	0.27	0.34	0.41	0.49	0.58	0.67	0.76	0.86
	13.7	7-5	9-1	10-6	11-9	12-11	13-11	14-11	15-10	16-9	17-6	18-3	19-0
		0.05	0.09	0.14	0.19	0.25	0.32	0.39	0.46	0.54	0.62	0.71	0.80
	16.0	6-11	8-5	9-9	10-11	11-11	12-11	13-9	14-8	15-5	16-2	16-11	17-7
		0.04	0.08	0.13	0.18	0.23	0.29	0.36	0.43	0.50	0.58	0.66	0.74
	19.2	6-4	7-8	8-11	9-11	10-11	11-9	12-7	13-4	14-1	14-9	15-5	16-1
		0.04	0.08	0.12	0.16	0.21	0.27	0.33	0.39	0.46	0.53	0.60	0.68
	24.0	5-8	6-11	8-0	8-11	9-9	10-6	11-3	11-11	12-7	13-2	13-9	14-4
		0.04	0.07	0.10	0.14	0.19	0.24	0.29	0.35	0.41	0.47	0.54	0.61

Note: The required modulus of elasticity, "E", in 1,000,000 pounds per inch is shown below each span.

TABLE R-11 (cont.)

RAFTERS: Spans are measured along the horizontal projection and loads are considered as applied on the horizontal projection.

	Extreme Fiber Stress in Bending, "F <sub>b</sub> " (psi).												RAFTER SPACING SIZE (IN)
	1400	1500	1600	1700	1800	1900	2000	2100	2200	2400	2700	3000	
8-0	8-3	8-6	8-9	9-0	9-3	9-6	9-9	10-0	10-5	10-5	11-1	11-1	12.0
0.96	1.06	1.17	1.28	1.39	1.51	1.63	1.76	1.88	2.15	2.15	2.56	2.56	
7-5	7-9	8-0	8-3	8-5	8-8	8-11	9-2	9-4	9-9	10-4	10-4	10-4	13.7
0.89	0.99	1.09	1.20	1.30	1.41	1.53	1.64	1.76	2.01	2.01	2.40	2.40	
6-11	7-2	7-5	7-7	7-10	8-0	8-3	8-5	8-8	9-0	9-0	9-7	10-1	16.0
0.83	0.92	1.01	1.11	1.21	1.31	1.41	1.52	1.63	1.86	1.86	2.22	2.60	
6-4	6-6	6-9	6-11	7-2	7-4	7-6	7-9	7-11	8-3	8-3	8-9	9-3	19.2
0.76	0.84	0.92	1.01	1.10	1.20	1.29	1.39	1.49	1.70	1.70	2.03	2.37	
5-8	5-10	6-0	6-3	6-5	6-7	6-9	6-11	7-1	7-5	7-5	7-10	8-3	24.0
0.68	0.75	0.83	0.90	0.99	1.07	1.15	1.24	1.33	1.52	1.52	1.81	2.12	
12-6	13-0	13-5	13-10	14-2	14-7	15-0	15-4	15-8	16-5	16-5	17-5	17-5	12.0
0.96	1.06	1.17	1.28	1.39	1.51	1.63	1.76	1.88	2.15	2.15	2.56	2.56	
11-9	12-2	12-6	12-11	13-3	13-8	14-0	14-4	14-8	15-4	15-4	16-3	16-3	13.7
0.89	0.95	1.09	1.20	1.30	1.41	1.53	1.64	1.76	2.01	2.01	2.40	2.40	
10-10	11-3	11-7	11-11	12-4	12-8	13-0	13-3	13-7	14-2	14-2	15-1	15-11	16.0
0.83	0.92	1.01	1.11	1.21	1.31	1.41	1.52	1.63	1.86	1.86	2.22	2.60	
9-11	10-3	10-7	10-11	11-3	11-6	11-10	12-2	12-5	13-0	13-0	13-9	14-5	19.2
0.76	0.84	0.92	1.01	1.10	1.20	1.29	1.39	1.49	1.70	1.70	2.03	2.37	
8-10	9-2	9-6	9-9	10-0	10-4	10-7	10-10	11-1	11-7	11-7	12-4	13-0	24.0
0.68	0.75	0.83	0.90	0.99	1.07	1.15	1.24	1.33	1.52	1.52	1.81	2.12	



16-6 0.96	17-1 1.06	17-8 1.17	18-2 1.28	18-9 1.39	19-3 1.51	19-9 1.63	20-3 1.76	20-8 1.88	21-7 2.15	22-11 2.56		12.0	2x8
15-5 0.89	16-0 0.99	16-6 1.09	17-0 1.20	17-6 1.30	18-0 1.41	18-5 1.53	18-11 1.64	19-4 1.76	20-3 2.01	21-5 2.40		13.7	
14-4 0.83	14-10 0.92	15-3 1.01	15-9 1.11	16-3 1.21	16-8 1.31	17-1 1.41	17-6 1.52	17-11 1.63	18-8 1.86	19-10 2.22	20-11 2.60	16.0	
13-1 0.76	13-6 0.84	13-11 0.92	14-5 1.07	14-10 1.10	15-2 1.20	15-7 1.29	16-0 1.39	16-4 1.49	17-1 1.70	18-2 2.03	19-1 2.37	19.2	
11-8 0.68	12-1 0.75	12-6 0.83	12-10 0.90	13-3 0.99	13-7 1.07	13-11 1.15	14-4 1.24	14-8 1.33	15-3 1.52	16-3 1.81	17-1 2.12	24.0	
21-1 0.96	21-10 1.06	22-6 1.17	23-3 1.28	23-11 1.39	24-6 1.51	25-2 1.63	25-10 1.76	26-5 1.88	27-7 2.15	29-3 2.56		12.0	
19-8 0.89	20-5 0.99	21-1 1.09	21-9 1.20	22-4 1.30	22-11 1.41	23-7 1.53	24-2 1.64	24-8 1.76	25-10 2.01	27-4 2.40		13.7	
18-3 0.83	18-11 0.92	19-6 1.01	20-1 1.11	20-8 1.21	21-3 1.31	21-10 1.41	22-4 1.52	22-10 1.63	23-11 1.86	25-4 2.22	26-8 2.60	16.0	
16-8 0.76	17-3 0.84	17-10 0.92	18-4 1.01	18-11 1.10	19-5 1.20	19-11 1.29	20-5 1.39	20-10 1.49	21-10 1.70	23-2 2.03	24-5 2.37	19.2	
14-11 0.68	15-6 0.75	15-11 0.83	16-5 0.90	16-11 0.99	17-4 1.07	17-10 1.15	18-3 1.24	18-8 1.33	19-6 1.52	20-8 1.81	21-10 2.12	24.0	

Note: The required modulus of elasticity, "E", in 1,000,000 pounds per square inch is shown below each span.

**TABLE R-12  
MEDIUM OR HIGH SLOPE RAFTERS**  
No Ceiling Load  
Slope over 3 in 12  
Live Load - 40 lbs. per sq. ft.  
(heavy roof coverings)  
Use in Zone 1

**DESIGN CRITERIA:**  
Strength - 15 lbs. per sq. ft. dead load plus  
40 lbs. per sq. ft. live load determines  
required fiber stress.  
Deflection - For 40 lbs. per sq. ft. live load.  
Limited to span in inches divided by 180.

RAFTER SIZE SPACING (IN) (IN)	Extreme Fiber Stress in Bending, "F <sub>b</sub> " (psi).												
	200	300	400	500	600	700	800	900	1000	1100	1200	1300	
12.0	2.8	3.4	3.10	4.4	4.9	5.1	5.5	5.9	6.1	6.5	6.8	6.11	
	0.05	0.08	0.14	0.20	0.26	0.33	0.41	0.49	0.57	0.66	0.75	0.84	
	2.7	3.1	3.7	4.0	4.5	4.9	5.1	5.5	5.8	6.0	6.3	6.6	
13.7	0.05	0.09	0.13	0.19	0.25	0.31	0.38	0.46	0.53	0.61	0.70	0.79	
	2.4	2.11	3.4	3.9	4.1	4.5	4.9	5.0	5.3	5.6	5.9	6.0	
	0.04	0.08	0.12	0.17	0.23	0.29	0.35	0.42	0.49	0.57	0.65	0.73	
19.2	2.2	2.6	3.1	3.5	3.9	4.0	4.4	4.7	4.10	5.1	5.3	5.6	
	0.04	0.07	0.11	0.16	0.21	0.26	0.32	0.38	0.45	0.52	0.59	0.67	
	1.11	2.4	2.9	3.1	3.4	3.7	3.10	4.1	4.4	4.6	4.9	4.11	
24.0	0.04	0.07	0.10	0.14	0.19	0.24	0.29	0.34	0.40	0.46	0.53	0.60	
	4.3	5.3	6.1	6.9	7.5	8.0	8.7	9.1	9.7	10.0	10.6	10.11	
	0.05	0.09	0.14	0.20	0.26	0.33	0.41	0.49	0.57	0.66	0.75	0.84	
13.7	4.0	4.11	5.8	6.4	6.11	7.6	8.0	8.6	8.11	9.5	9.10	10.3	
	0.05	0.09	0.13	0.19	0.25	0.31	0.38	0.46	0.53	0.61	0.70	0.79	
	3.8	4.6	5.3	5.10	6.5	6.11	7.5	7.10	8.3	8.8	9.1	9.5	
16.0	0.04	0.08	0.12	0.17	0.23	0.29	0.35	0.42	0.49	0.57	0.65	0.73	
	3.5	4.2	4.9	5.4	5.10	6.4	6.9	7.2	7.7	7.11	8.3	8.8	
	0.04	0.07	0.11	0.16	0.21	0.26	0.32	0.38	0.45	0.52	0.59	0.67	
19.2	3.0	3.8	4.3	4.9	5.3	5.8	6.1	6.5	6.9	7.1	7.5	7.9	
	0.04	0.07	0.10	0.14	0.19	0.24	0.29	0.34	0.40	0.46	0.53	0.60	
	2.4	3.0	3.8	4.3	4.9	5.3	5.8	6.1	6.5	6.9	7.1	7.5	
24.0	0.04	0.07	0.10	0.14	0.19	0.24	0.29	0.34	0.40	0.46	0.53	0.60	

Appendix

12.0	5-8	6-11	8-0	8-11	9-9	10-7	11-3	12-0	12-7	13-3	13-10	14-5
	0.05	0.09	0.14	0.20	0.26	0.33	0.41	0.49	0.57	0.66	0.75	0.84
13.7	5-3	6-6	7-6	8-4	9-2	9-11	10-7	11-2	11-10	12-5	12-11	13-6
	0.05	0.09	0.13	0.19	0.25	0.31	0.28	0.46	0.53	0.61	0.70	0.79
16.0	4-11	6-0	6-11	7-9	8-6	9-2	9-9	10-4	10-11	11-6	12-0	12-6
	0.04	0.08	0.12	0.17	0.23	0.29	0.35	0.42	0.49	0.57	0.65	0.73
19.2	4-6	5-6	6-4	7-1	7-9	8-4	8-11	9-6	10-0	10-6	10-11	11-5
	0.04	0.07	0.11	0.16	0.21	0.26	0.32	0.38	0.45	0.52	0.59	0.67
24.0	4-0	4-11	5-8	6-4	6-11	7-6	8-0	8-6	8-11	9-4	9-9	10-2
	0.04	0.07	0.10	0.14	0.19	0.24	0.29	0.34	0.40	0.46	0.53	0.60
12.0	7-2	8-10	10-2	11-5	12-6	13-6	14-5	15-3	16-1	16-11	17-8	18-4
	0.05	0.09	0.14	0.20	0.26	0.33	0.41	0.49	0.57	0.66	0.75	0.84
13.7	6-9	8-3	9-6	10-8	11-8	12-7	13-6	14-3	15-1	15-10	16-6	17-2
	0.05	0.09	0.13	0.19	0.25	0.31	0.38	0.46	0.53	0.61	0.70	0.79
16.0	6-3	7-8	8-10	9-10	10-10	11-8	12-6	13-3	13-11	14-8	15-3	15-11
	0.04	0.08	0.12	0.17	0.23	0.29	0.35	0.42	0.49	0.57	0.65	0.73
19.2	5-8	7-0	8-1	8-0	9-10	10-8	11-5	12-1	12-9	13-4	13-11	14-6
	0.04	0.07	0.11	0.16	0.21	0.26	0.32	0.38	0.45	0.52	0.59	0.67
24.0	5-1	6-3	7-2	8-1	8-10	9-6	10-2	10-10	11-5	11-11	12-6	13-0
	0.04	0.07	0.10	0.14	0.19	0.24	0.29	0.34	0.40	0.46	0.53	0.60

Note: The required modulus of elasticity, "E", in 1,000,000 pounds per square inch is shown below each span.

TABLE R-12 (cont.)

RAFTERS: Spans are measured along the horizontal projection and loads are considered as applied on the horizontal projection.

	Extreme Fiber Stress in Bonding, "F <sub>b</sub> " (psi).													RAFTER SPACING SIZE (IN)
	1400	1500	1600	1700	1800	1900	2000	2100	2200	2400	2700	3000		
7-3	7-6	7-8	7-11	8-2	8-5	8-7	8-10	8-10	9-0	9-5	10-0		12.0	
0.94	1.05	1.15	1.26	1.38	1.49	1.61	1.73	1.73	1.86	2.12	2.53			
6-9	7-0	7-3	7-5	7-8	7-10	8-1	8-3	8-5	8-5	8-10	9-4		13.7	
0.88	0.98	1.08	1.18	1.29	1.40	1.51	1.62	1.74	1.74	1.98	2.36			
6-3	6-6	6-8	6-11	7-1	7-3	7-6	7-8	7-10	7-10	8-2	8-8	9-2	16.0	
0.82	0.91	1.00	1.09	1.19	1.29	1.40	1.50	1.61	1.61	1.83	2.19	2.56	24.4	
5-8	5-11	6-1	6-3	6-6	6-8	6-10	7-0	7-2	7-2	7-6	7-11	8-4		
0.75	0.83	0.91	1.00	1.09	1.18	1.27	1.37	1.47	1.47	1.67	2.00	2.34	19.2	
5-1	5-3	5-5	5-7	5-9	5-11	6-1	6-3	6-5	6-5	6-8	7-1	7-6	24.0	
0.67	0.74	0.82	0.89	0.97	1.06	1.14	1.23	1.31	1.31	1.50	1.79	2.09		
11-4	11-9	12-1	12-6	12-10	13-2	13-6	13-10	13-10	14-2	14-10	15-9		12.0	
0.84	1.05	1.15	1.28	1.38	1.49	1.61	1.73	1.73	1.86	2.12	2.53			
10-7	11-0	11-4	11-8	12-0	12-4	12-8	13-0	13-0	13-3	13-10	14-9		13.7	
0.88	0.98	1.08	1.18	1.29	1.40	1.51	1.62	1.74	1.74	1.98	2.36			
9-10	10-2	10-6	10-10	11-1	11-5	11-9	12-0	12-4	12-4	12-10	13-7	14-4	16.0	
0.82	0.91	1.00	1.09	1.19	1.29	1.40	1.50	1.61	1.61	1.83	2.19	2.56	24.4	
8-11	9-3	9-7	9-10	10-2	10-5	10-8	11-0	11-3	11-3	11-9	12-5	13-1		
0.75	0.83	0.91	1.00	1.09	1.18	1.27	1.37	1.47	1.47	1.67	2.00	2.34	19.2	
8-0	8-3	8-7	8-10	9-1	9-4	9-7	9-10	10-0	10-0	10-6	11-1	11-9	24.0	
0.67	0.74	0.82	0.89	0.97	1.06	1.14	1.23	1.31	1.31	1.50	1.79	2.09		

Appendix

14-11	15-5	16-0	16-5	16-11	17-5	17-10	18-3	18-9	19-7	20-9	12.0
0.94	1.05	1.15	1.26	1.38	1.49	1.61	1.73	1.86	2.12	2.53	
14-0	14-6	14-11	15-5	15-10	16-3	16-8	17-1	17-6	18-3	19-5	13.7
0.88	0.98	1.08	1.18	1.29	1.40	1.51	1.62	1.74	1.98	2.36	
12-11	13-5	13-10	14-3	14-8	15-1	15-5	15-10	16-3	16-11	18-0	18-11
0.82	0.91	1.00	1.09	1.19	1.29	1.40	1.50	1.61	1.83	2.19	2.56
11-10	12-3	12-7	13-0	13-5	13-8	14-1	14-5	14-10	15-5	16-5	17-3
0.75	0.83	0.91	1.00	1.09	1.18	1.27	1.37	1.47	1.67	2.00	2.34
10-7	10-11	11-3	11-8	12-0	12-4	12-7	12-11	13-3	13-10	14-8	15-5
0.67	0.74	0.82	0.89	0.97	1.06	1.14	1.23	1.31	1.50	1.79	2.09
19-1	19-9	20-4	21-0	21-7	22-2	22-9	23-4	23-11	24-11	26-6	12.0
0.94	1.05	1.15	1.26	1.38	1.49	1.61	1.73	1.86	2.12	2.53	
17-10	18-5	19-1	19-8	20-2	20-9	21-4	21-10	22-4	23-4	24-9	13.7
0.88	0.98	1.08	1.18	1.29	1.40	1.51	1.62	1.74	1.98	2.36	
16-6	17-1	17-8	18-2	18-9	19-3	19-9	20-2	20-8	21-7	22-11	24.2
0.82	0.91	1.00	1.09	1.19	1.29	1.40	1.50	1.61	1.83	2.18	2.56
15-1	15-7	16-1	16-7	17-1	17-7	18-0	18-5	18-11	19-9	20-11	22-1
0.75	0.83	0.91	1.00	1.09	1.18	1.27	1.37	1.47	1.67	2.00	2.34
13-6	13-11	14-5	14-10	15-3	15-8	16-1	16-6	16-11	17-8	18-9	19-9
0.67	0.74	0.82	0.89	0.97	1.06	1.14	1.23	1.31	1.50	1.79	2.09

Note: The required modulus of elasticity, "E" in 1,000,000 pounds per square inch is shown below each span.

TABLE R-14  
MEDIUM OR HIGH SLOPE RAFTERS

No Ceiling Load  
Slope over 3 in 12  
Live Load - 30 lbs. per sq. ft.  
(Light roof covering)  
Use in Zone 2

DESIGN CRITERIA:

Strength - 7 lbs. per sq. ft. dead load plus  
30 lbs. per sq. ft. live load determines  
required fiber stress.  
Deflection - For 30 lbs. per sq. ft. live load.  
Limited to span in inches divided by 180.

RAFTER SIZE SPACING (IN)	Extreme Fiber Stress in Bending, "F <sub>b</sub> " (psi)												
	200	300	400	500	600	700	800	900	1000	1100	1200	1300	
12.0	3.4	4.1	4.8	5.3	5.9	6.3	6.8	7.1	7.5	7.9	8.2	8.6	
	0.07	0.13	0.20	0.27	0.36	0.45	0.55	0.66	0.77	0.89	1.02	1.15	
	3.1	3.70	4.5	4.11	5.5	5.10	6.3	6.7	6.11	7.3	7.7	7.11	
13.7	0.06	0.12	0.18	0.26	0.34	0.42	0.52	0.62	0.72	0.84	0.95	1.07	
	2.11	3.6	4.1	4.7	5.0	5.5	5.9	6.1	6.5	6.9	7.1	7.4	
	0.06	0.11	0.17	0.24	0.31	0.39	0.46	0.57	0.67	0.77	0.88	0.99	
16.0	2.8	3.3	3.9	4.2	4.7	4.11	5.3	5.7	5.10	6.2	6.5	6.8	
	0.05	0.10	0.15	0.22	0.28	0.36	0.44	0.52	0.61	0.71	0.80	0.91	
	2.4	2.11	2.4	3.9	4.1	4.5	4.8	5.0	5.3	5.5	5.9	6.0	
19.2	0.05	0.09	0.14	0.19	0.25	0.32	0.39	0.47	0.55	0.63	0.72	0.81	
	5.3	6.5	7.5	8.3	9.1	9.9	10.5	11.1	11.8	12.3	12.9	13.4	
	0.07	0.13	0.20	0.27	0.36	0.45	0.55	0.66	0.77	0.89	1.02	1.15	
13.7	4.11	6.0	6.11	7.9	8.5	9.2	9.9	10.4	10.11	11.5	12.0	12.5	
	0.06	0.12	0.18	0.26	0.34	0.42	0.52	0.62	0.72	0.84	0.95	1.07	
	4.6	5.6	6.5	7.2	7.10	8.5	9.1	9.7	10.1	10.7	11.1	11.6	
16.0	0.06	0.11	0.17	0.24	0.31	0.39	0.48	0.57	0.67	0.77	0.88	0.99	
	4.2	5.1	5.10	6.8	7.2	7.9	8.3	8.9	9.3	9.8	10.1	10.6	
	0.05	0.10	0.15	0.22	0.28	0.36	0.44	0.52	0.61	0.71	0.80	0.91	
19.2	3.8	4.6	5.3	5.10	6.5	6.11	7.5	7.10	8.3	8.8	9.1	9.5	
	0.05	0.09	0.14	0.19	0.25	0.32	0.39	0.47	0.55	0.63	0.72	0.81	

Appendix

12.0	6-11	8-5	9-9	10-11	11-11	12-10	13-9	14-7	15-5	16-2	16-10	17-7
	0.07	0.13	0.20	0.27	0.36	0.45	0.55	0.66	0.77	0.89	1.02	1.15
13.7	6-5	7-11	9-1	10-2	11-2	12-10	13-8	14-5	15-1	15-9	16-5	16-5
	0.06	0.12	0.18	0.26	0.34	0.42	0.52	0.62	0.72	0.84	0.95	1.07
16.0	6-0	7-4	8-5	9-5	10-4	11-2	11-11	12-8	13-4	14-0	14-7	15-2
	0.06	0.11	0.17	0.24	0.31	0.39	0.48	0.57	0.67	0.77	0.88	0.99
19.2	5-5	6-8	7-8	8-7	9-5	10-2	10-11	11-6	12-2	12-9	13-4	13-10
	0.05	0.10	0.15	0.22	0.28	0.36	0.44	0.52	0.61	0.71	0.80	0.91
24.0	4-10	6-0	6-11	7-8	8-5	9-1	9-9	10-4	10-11	11-5	11-11	12-5
	0.05	0.09	0.14	0.19	0.25	0.32	0.39	0.47	0.55	0.63	0.72	0.81
12.0	8-9	10-9	12-5	13-11	15-2	16-5	17-7	18-7	19-8	20-7	21-6	22-5
	0.07	0.13	0.20	0.27	0.36	0.45	0.55	0.66	0.77	0.89	1.02	1.15
13.7	8-3	10-1	11-7	13-0	14-3	15-4	16-5	17-5	18-4	19-3	20-1	20-11
	0.06	0.12	0.18	0.26	0.34	0.42	0.52	0.62	0.72	0.84	0.95	1.07
16.0	7-7	9-4	10-8	12-0	13-2	14-3	15-2	16-2	17-0	17-10	18-7	19-5
	0.07	0.12	0.18	0.26	0.34	0.43	0.53	0.63	0.74	0.85	0.97	1.09
19.2	6-11	8-6	9-10	11-0	12-0	13-0	13-11	14-9	15-6	16-3	17-0	17-8
	0.05	0.10	0.15	0.22	0.28	0.36	0.44	0.52	0.61	0.71	0.80	0.91
24.0	6-2	7-7	8-9	9-10	10-9	11-7	12-5	13-2	13-11	14-7	15-2	15-10
	0.05	0.09	0.14	0.19	0.25	0.32	0.39	0.47	0.55	0.63	0.72	0.81

Note: The required modulus of elasticity, "E", in 1,000,000 pounds per square inch is shown below each span.

TABLE R-14 (cont.)

RAFTERS: Seams are measured along the horizontal projection and loads are considered as applied on the horizontal projection.

	Extreme Fiber Stress in Bending, "F <sub>b</sub> " (psi).											RAFTER SPACING SIZE (IN)
	1400	1500	1600	1700	1800	1900	2000	2100	2200	2400	2700	
8-9	9.1	9.5	9.8	10.0	10.3	10.6	10.9	11.0				12.0
1.28	1.42	1.57	1.72	1.87	2.03	2.19	2.36	2.53				
8-3	8.6	8.9	9.1	9.4	9.7	9.10	10.1	10.4				13.7
1.20	1.33	1.47	1.61	1.75	1.90	2.05	2.20	2.36				
7-7	7.11	8.2	8.5	8.8	8.10	9.1	9.4	9.7	10.0			16.0
1.11	1.23	1.36	1.49	1.62	1.76	1.90	2.04	2.19	2.40			2x4
6-11	7.2	7.5	7.8	7.11	8.1	8.4	8.6	8.9	9.1			19.2
1.01	1.12	1.24	1.36	1.48	1.60	1.73	1.85	2.00	2.28			
6-3	6.5	6.8	6.10	7.1	7.3	7.5	7.7	7.9	8.2			8.8
0.91	1.01	1.11	1.21	1.32	1.43	1.55	1.67	1.79	2.04			24.0
13-10	14.4	14.9	15.3	15.8	16.1	16.6	16.11	17.4				12.0
1.28	1.42	1.57	1.72	1.87	2.03	2.19	2.38	2.53				
12-11	13.4	13.10	14.3	14.8	15.1	15.5	15.10	16.2				13.7
1.20	1.33	1.47	1.61	1.75	1.90	2.05	2.20	2.36				
12-0	12.5	12.9	13.2	13.7	13.11	14.4	14.8	15.0	15.8			16.0
1.11	1.23	1.36	1.49	1.62	1.76	1.90	2.04	2.19	2.49			2x6
10-11	11.4	11.8	12.0	12.5	12.9	13.1	13.4	13.8	14.4			18.2
1.01	1.12	1.24	1.36	1.48	1.60	1.73	1.86	2.00	2.28			
9-9	10.1	10.5	10.9	11.1	11.5	11.8	12.0	12.3	12.9			13.7
0.91	1.01	1.11	1.21	1.32	1.43	1.55	1.67	1.79	2.04			24.0



Appendix

18-2	18-10	19-6	20-1	20-8	21-3	21-9	22-4	22-10			12.0
1.28	1.42	1.57	1.72	1.87	2.03	2.19	2.36	2.55			
17-0	17-8	18-2	18-9	19-4	19-10	20-4	20-10	21-4			13.7
1.20	1.33	1.47	1.61	1.75	1.90	2.05	2.20	2.36			
15-9	16-4	16-10	17-4	17-11	18-4	18-10	19-4	19-9	20-3	20-8	18.0
1.11	1.23	1.36	1.49	1.62	1.76	1.90	2.04	2.19	2.48		
14-5	14-11	15-5	15-10	16-4	16-9	17-2	17-8	18-1	18-10		19.2
1.01	1.12	1.24	1.36	1.48	1.60	1.73	1.86	2.00	2.28		
12-10	13-4	13-9	14-2	14-7	15-0	15-5	15-9	16-2	16-10	17-11	24.0
0.91	1.01	1.11	1.21	1.32	1.43	1.55	1.67	1.79	2.04	2.43	
23-3	24-1	24-10	25-7	26-4	27-1	27-9	28-5	29-1			12.0
1.28	1.42	1.57	1.72	1.87	2.03	2.19	2.36	2.53			
21-9	22-6	23-3	23-11	24-8	25-4	26-0	26-7	27-3			13.7
1.20	1.33	1.47	1.61	1.75	1.90	2.05	2.20	2.36			
20-1	20-10	21-6	22-2	22-10	23-5	24-1	24-8	25-3			16.0
1.22	1.35	1.49	1.63	1.78	1.93	2.08	2.24	2.40			
18-4	19-0	19-8	20-3	20-10	21-5	21-11	22-6	23-0	24-1		19.2
1.01	1.12	1.24	1.36	1.48	1.60	1.73	1.86	2.00	2.28		
16-5	17-0	17-7	18-1	18-7	19-2	19-8	20-1	20-7	21-6	22-10	24.0
0.91	1.01	1.11	1.21	1.32	1.43	1.55	1.67	1.79	2.04	2.43	

Note: The required modulus of elasticity, "E", in 1,000,000 pounds per square inch is shown below each span.

**TABLE R-15**  
**MEDIUM OR HIGH SLOPE RAFTERS**  
 No Ceiling Load  
 Slope over 3 in 12  
 Live Load - 40 lbs. per sq. ft.  
 (Light roof covering)  
 Use in Zone I

**DESIGN CRITERIA:**  
 Strength - 7 lbs. per sq. ft. dead load plus  
 40 lbs. per sq. ft. live load determines  
 required fiber stress.  
 Deflection - For 40 lbs. per sq. ft. live load,  
 limited to span in inches divided by 180.

RAFTER SIZE SPACING (IN)	Extreme Fiber Stress in Bending, "F <sub>b</sub> " (psi).											
	200	300	400	500	600	700	800	900	1000	1100	1200	1300
12.0	2-11	3-7	4-2	4-8	5-1	5-6	5-11	6-3	6-7	6-11	7-3	7-6
	0-06	0-12	0-18	0-25	0-34	0-42	0-52	0-62	0-72	0-83	0-95	1-07
	13.7	2-9	3-5	3-11	4-4	4-9	5-2	5-6	5-10	6-2	6-9	7-0
16.0	2-7	3-2	3-7	4-0	4-5	4-9	5-1	5-5	5-8	6-0	6-3	6-6
	0-06	0-10	0-16	0-22	0-29	0-37	0-45	0-53	0-62	0-72	0-82	0-93
	19.2	2-4	2-10	3-4	3-8	4-0	4-4	4-8	5-2	5-6	5-9	5-11
24.0	2-1	2-7	2-11	3-4	3-7	3-11	4-2	4-5	4-8	4-11	5-1	5-4
	0-05	0-08	0-13	0-18	0-24	0-30	0-36	0-44	0-51	0-59	0-67	0-76
	12.0	4-8	5-8	6-7	7-4	8-0	8-8	9-3	9-10	10-4	10-10	11-4
13.7	4-4	5-4	6-2	6-10	7-6	8-1	8-8	9-2	9-8	10-2	10-7	11-1
	0-06	0-11	0-17	0-24	0-31	0-40	0-48	0-56	0-67	0-78	0-89	1-00
	16.0	4-0	4-11	5-6	6-4	6-11	7-6	8-0	8-6	9-0	9-5	10-3
2x6	0-06	0-10	0-16	0-22	0-29	0-37	0-45	0-53	0-62	0-72	0-82	0-93
	19.2	3-8	4-6	5-2	5-9	6-4	6-10	7-4	7-9	8-2	8-7	9-4
	0-05	0-09	0-14	0-20	0-26	0-33	0-41	0-49	0-57	0-66	0-75	0-85
24.0	3-3	4-0	4-8	5-2	5-8	6-2	6-7	6-11	7-4	7-8	8-0	8-4
	0-06	0-08	0-13	0-18	0-24	0-30	0-36	0-44	0-51	0-59	0-67	0-76

Appendix

12.0	8-1	7-6	8-8	9-8	10-7	11-5	12-3	12-11	13-8	14-4	14-11	15-7
	0.06	0.12	0.18	0.25	0.34	0.42	0.52	0.62	0.72	0.83	0.95	1.07
13.7	5-9	7-0	8-1	9-0	9-11	10-8	11-5	12-1	12-9	13-5	14-0	14-7
	0.06	0.11	0.17	0.24	0.31	0.40	0.48	0.58	0.67	0.78	0.88	1.00
2x8	5-3	6-6	7-6	8-4	9-2	9-11	10-7	11-3	11-10	12-5	12-11	13-6
	0.06	0.10	0.16	0.22	0.29	0.37	0.45	0.53	0.62	0.72	0.82	0.93
19.2	4-10	5-11	6-10	7-8	8-4	9-0	9-6	10-3	10-10	11-4	11-10	12-4
	0.05	0.09	0.14	0.20	0.26	0.33	0.41	0.49	0.57	0.66	0.75	0.85
24.0	4-4	5-3	6-1	6-10	7-6	8-1	8-8	9-2	9-8	10-2	10-7	11-0
	0.05	0.08	0.13	0.18	0.24	0.30	0.36	0.44	0.51	0.59	0.67	0.76
12.0	7-9	9-6	11-0	12-4	13-6	14-7	15-7	16-6	17-5	18-3	19-1	19-10
	0.06	0.12	0.18	0.25	0.34	0.42	0.52	0.62	0.72	0.83	0.95	1.07
13.7	7-3	8-11	10-4	11-6	12-7	13-8	14-7	15-5	16-4	17-1	17-10	18-7
	0.06	0.11	0.17	0.24	0.31	0.40	0.48	0.58	0.67	0.78	0.88	1.00
2x10	6-9	8-3	9-6	10-8	11-8	12-7	13-6	14-4	15-1	15-10	16-6	17-2
	0.06	0.10	0.16	0.22	0.29	0.37	0.45	0.53	0.62	0.72	0.82	0.93
19.2	6-2	7-7	8-9	9-9	10-8	11-6	12-4	13-1	13-9	14-5	15-1	15-8
	0.05	0.09	0.14	0.20	0.26	0.33	0.41	0.49	0.57	0.66	0.75	0.85
24.0	5-6	6-8	7-9	8-9	9-6	10-4	11-0	11-8	12-4	12-11	13-6	14-1
	0.05	0.08	0.13	0.18	0.24	0.30	0.36	0.44	0.51	0.59	0.67	0.76

Note: The required modulus of elasticity, "E", in 1,000,000 pounds per square inch is shown below each span.

TABLE R-15 (cont.)

RAFTERS: Spans are measured along the horizontal projection and loads are considered as applied on the horizontal projection.

		Extreme Fiber Stress in Bending, "F <sub>b</sub> " (psi).												RAFTER SPACING SIZE (IN)	
		1500	1600	1700	1800	1900	2000	2100	2200	2400	2700				
1400															
7-10	8-1	8-4	8-7	8-10	8-10	9-1	9-4	9-7	9-9				12.0		
	1-19	1-32	1-46	1-60	1-74	1-89	2-04	2-19	2-35						
7-4	7-7	7-10	8-0	8-3	8-6	8-9	8-11	8-11	9-2	9-7			13.7		
	1-12	1-24	1-37	1-50	1-63	1-77	1-91	2-05	2-20	2-51					
6-9	7-0	7-3	7-5	7-8	7-8	7-10	8-1	8-3	8-6	8-10			2x4		
	1-03	1-15	1-26	1-38	1-51	1-64	1-77	1-90	2-04	2-32					
6-2	6-5	6-7	6-10	7-0	7-0	7-2	7-4	7-7	7-9	8-1	8-7				
0-84	1-05	1-15	1-26	1-38	1-38	1-49	1-61	1-74	1-86	2-12	2-53				
5-6	5-8	5-11	6-1	6-3	6-3	6-5	6-7	6-9	6-11	7-3	7-8				
0-64	0-94	1-03	1-13	1-23	1-23	1-34	1-44	1-55	1-66	1-90	2-26				
12-3	12-8	13-1	13-6	13-11	13-11	14-3	14-8	15-0	15-4				12.0		
1-19	1-32	1-46	1-60	1-74	1-74	1-89	2-04	2-19	2-35						
11-6	11-10	12-3	12-8	13-0	13-0	13-4	13-8	14-0	14-4	15-0					
1-12	1-24	1-37	1-50	1-63	1-63	1-77	1-91	2-05	2-20	2-51			13.7		
10-7	11-0	11-4	11-8	12-0	12-0	12-4	12-8	13-0	13-4	13-11					
1-05	1-15	1-26	1-38	1-51	1-51	1-64	1-77	1-90	2-04	2-32			2x6		
9-8	10-0	10-4	10-8	11-0	11-0	11-3	11-7	11-10	12-2	12-8	13-5				
0-94	1-05	1-15	1-26	1-38	1-38	1-49	1-61	1-74	1-86	2-12	2-53				
8-8	9-0	9-3	9-7	9-10	9-10	10-1	10-4	10-7	10-10	11-4	12-0				
0-84	0-94	1-03	1-13	1-23	1-23	1-34	1-44	1-55	1-66	1-90	2-26				

Appendix

16-2	16-9	17-3	17-10	18-4	18-10	19-4	19-9	20-3			12.0
1.19	1.32	1.46	1.60	1.74	1.89	2.04	2.19	2.35			
15-1	15-8	16-2	16-8	17-2	17-7	18-1	18-6	18-11	19-9		13.7
1.12	1.24	1.37	1.50	1.63	1.77	1.91	2.05	2.20	2.51		
14-0	14-6	14-11	15-5	15-10	16-4	16-9	17-2	17-6	18-4		2x8
1.03	1.15	1.26	1.38	1.51	1.64	1.77	1.90	2.04	2.32		
12-9	13-3	13-8	14-1	14-6	14-11	15-3	15-8	16-0	16-9	17-9	16.0
0.94	1.05	1.15	1.26	1.38	1.49	1.61	1.74	1.86	2.12	2.53	19.2
11-5	11-10	12-3	12-7	12-11	13-4	13-8	14-0	14-4	14-11	15-10	24.0
0.84	0.94	1.03	1.13	1.23	1.34	1.44	1.55	1.66	1.90	2.26	
20-7	21-4	22-0	22-9	23-4	24-0	24-8	25-3	25-10			12.0
1.19	1.32	1.46	1.60	1.74	1.89	2.04	2.19	2.35			
19-3	19-11	20-7	21-3	21-10	22-6	23-1	23-7	24-2	25-3		13.7
1.12	1.24	1.37	1.50	1.63	1.77	1.91	2.05	2.20	2.51		
17-10	18-6	19-1	19-8	20-3	20-10	21-4	21-10	22-4	23-4		2x10
1.03	1.15	1.26	1.38	1.51	1.64	1.77	1.90	2.04	2.32		
16-4	16-10	17-5	17-11	18-6	19-0	19-6	19-11	20-5	21-4	22-8	16.0
0.94	1.05	1.15	1.26	1.38	1.49	1.61	1.74	1.86	2.12	2.53	19.2
14-7	15-1	15-7	16-1	16-6	17-0	17-5	17-10	18-3	19-1	20-3	24.0
0.84	0.94	1.03	1.13	1.23	1.34	1.44	1.55	1.66	1.90	2.26	

Note: The required modulus of elasticity, "E", in 1,000,000 pounds per square inch is shown below each span.

**TABLE TSM-1**  
**TWO-SPAN FLOOR JOISTS**  
40 Lbs. Per Sq. Ft. Live Load  
(All floors except attic floors)

**DESIGN CRITERIA:**  
Deflection - For 40 lbs. per sq. ft. live load on one span and 20 lbs. per sq. ft. on other. Limited to span in inches divided by 360.  
Strength - Live load of 40 lbs. per sq. ft. plus dead load of 10 lbs. per sq. ft. on both spans determines the required fiber stress value.

JOIST SIZE SPACING (IN)	Modulus of Elasticity, "E", in 1,000,000 psi															
	0.8	0.9	1.0	1.1	1.2	1.3	1.4	1.5	1.6	1.7	1.8	1.9	2.0	2.2	2.4	2.6
12.0	10-3	10-8	11-1	11-5	11-9	12-1	12-5	12-8	13-0	13-3	13-6	13-9	14-0	14-2	14-5	14-8
	10-6	11-0	11-3	11-7	12-0	12-3	12-6	12-9	13-2	13-5	13-8	14-1	14-4	14-7	15-0	15-3
	11-0	11-3	11-6	11-9	12-2	12-5	12-8	13-1	13-4	13-7	14-0	14-3	14-6	14-9	15-2	15-5
	11-3	11-6	11-9	12-2	12-5	12-8	13-1	13-4	13-7	14-0	14-3	14-6	14-9	15-2	15-5	15-8
13.7	9-4	9-9	10-1	10-5	10-8	11-0	11-3	11-6	11-9	12-0	12-3	12-6	12-8	12-11	13-2	13-4
	9-7	10-0	10-3	10-6	10-9	11-1	11-4	11-7	12-0	12-3	12-6	12-9	13-1	13-4	13-7	13-9
	10-0	10-3	10-6	10-9	11-1	11-4	11-7	12-0	12-3	12-6	12-9	13-1	13-4	13-7	14-0	14-2
	10-3	10-6	10-9	11-1	11-4	11-7	12-0	12-3	12-6	12-9	13-1	13-4	13-7	14-0	14-2	14-5
16.0	8-9	9-2	9-6	9-9	10-1	10-4	10-7	10-7	11-1	11-4	11-5	11-9	11-11	12-2	12-4	12-6
	9-2	9-5	9-9	10-1	10-4	10-7	10-7	11-1	11-4	11-4	11-5	11-9	11-11	12-2	12-4	12-6
	9-5	9-8	10-1	10-4	10-7	10-7	11-1	11-4	11-4	11-5	11-9	11-11	12-2	12-4	12-6	12-8
	9-8	10-1	10-4	10-7	10-7	11-1	11-4	11-4	11-5	11-9	11-11	12-2	12-4	12-6	12-8	13-0
24.0	8-2	8-6	8-9	9-1	9-4	9-7	9-10	10-1	10-3	10-6	10-8	10-11	11-1	11-3	11-5	11-7
	8-5	8-9	9-1	9-4	9-7	9-10	10-1	10-3	10-6	10-8	10-11	11-1	11-3	11-5	11-7	11-9
	8-8	9-1	9-4	9-7	9-10	10-1	10-3	10-6	10-8	10-11	11-1	11-3	11-5	11-7	11-9	12-1
	9-1	9-4	9-7	9-10	10-1	10-3	10-6	10-8	10-11	11-1	11-3	11-5	11-7	11-9	12-1	12-3
12.0	13-7	14-1	14-7	15-1	15-6	15-11	15-4	15-9	17-1	17-5	17-9	18-1	18-5	18-9	19-0	19-4
	14-0	14-4	14-9	15-3	15-8	16-1	16-4	16-8	17-1	17-5	17-9	18-1	18-5	18-9	19-0	19-4
	14-3	14-7	15-1	15-5	16-0	16-3	16-7	17-0	17-4	17-8	18-1	18-5	18-9	19-0	19-4	19-8
	14-6	15-0	15-4	15-8	16-2	16-6	16-9	17-3	17-7	18-0	18-4	18-8	19-0	19-4	19-8	20-0
13.7	13-0	13-6	14-0	14-5	14-10	15-3	15-8	16-0	16-4	16-8	17-0	17-4	17-7	17-11	18-2	18-6
	13-3	13-9	14-3	14-8	15-1	15-6	16-0	16-4	16-8	17-0	17-4	17-7	18-1	18-5	19-0	19-4
	13-6	14-2	14-6	15-1	15-5	16-0	16-4	16-8	17-0	17-4	17-7	18-1	18-5	19-0	19-4	19-8
	13-9	14-5	14-9	15-4	15-8	16-3	16-7	17-0	17-4	17-7	18-1	18-5	19-0	19-4	19-8	20-0
24.0	12-4	12-10	13-3	13-8	14-1	14-6	14-10	15-2	15-6	15-10	16-2	16-5	16-9	17-0	17-3	17-6
	12-7	12-13	13-6	14-1	14-5	15-0	15-4	16-0	16-4	16-8	17-0	17-3	17-7	17-10	18-0	18-3
	13-0	12-16	13-9	14-4	14-8	15-3	15-7	16-3	16-7	17-1	17-4	17-8	18-1	18-4	18-8	19-1
	13-3	12-19	14-0	14-5	15-0	15-4	15-9	16-4	16-8	17-2	17-5	17-9	18-2	18-6	19-0	19-3
19.2	11-7	12-1	12-6	12-11	13-3	13-8	14-0	14-4	14-7	14-11	15-2	15-6	15-9	16-0	16-3	16-6
	12-0	12-5	13-0	13-5	14-0	14-4	14-8	15-1	15-5	15-9	16-2	16-6	16-9	17-0	17-3	17-6
	12-3	12-8	13-3	13-8	14-3	14-7	15-0	15-4	15-8	16-1	16-5	16-8	17-0	17-3	17-6	17-9
	12-6	13-1	13-6	14-1	14-6	15-0	15-4	15-8	16-1	16-5	16-8	17-0	17-3	17-6	17-9	18-2
24.0	10-9	11-2	11-7	12-0	12-4	12-8	13-0	13-3	13-7	13-10	14-1	14-4	14-7	14-10	15-1	15-4
	11-2	11-6	12-0	12-4	12-8	13-0	13-3	13-7	13-10	14-1	14-4	14-7	14-10	15-1	15-4	15-7
	11-5	11-9	12-3	12-7	13-1	13-3	13-6	14-0	14-3	14-6	14-9	15-1	15-4	15-7	16-0	16-3
	11-8	12-2	12-6	13-0	13-4	13-6	14-0	14-3	14-6	14-9	15-1	15-4	15-7	16-0	16-3	16-6

Appendix

2x10	12.0	17.4	18.0	18.8	19.3	19.10	20.4	20-10	21-4	21-10	22-3	22-6	23-1	23-6	23-11	24-3	24-8
		1060	1150	1230	1310	1390	1460	1540	1610	1680	1750	1820	1880	1950	2010	2080	2140
	13.7	1110	1200	1290	1370	1450	1530	1610	1680	1760	1830	1900	1970	2040	2110	2170	2240
	16.0	1170	1260	1350	1440	1530	1610	1690	1770	1850	1930	2000	2070	2150	2220	2290	2360
2x12	19.2	1240	1340	1440	1530	1620	1710	1800	1880	1970	2050	2130	2200	2280	2360	2430	2500
		1340	1440	1550	1650	1750	1840	1940	2030	2120	2200	2280	2370	2460	2540	2620	2700
	24.0	1340	1440	1550	1650	1750	1840	1940	2030	2120	2200	2280	2370	2460	2540	2620	2700
	24.0	1340	1440	1550	1650	1750	1840	1940	2030	2120	2200	2280	2370	2460	2540	2620	2700
2x12	12.0	1060	1150	1230	1310	1390	1460	1540	1610	1680	1750	1820	1880	1950	2010	2080	2140
		1110	1200	1290	1370	1450	1530	1610	1680	1760	1830	1900	1970	2040	2110	2170	2240
	13.7	1170	1260	1350	1440	1530	1610	1690	1770	1850	1930	2000	2070	2150	2220	2290	2360
	16.0	1240	1340	1440	1530	1620	1710	1800	1880	1970	2050	2130	2200	2280	2360	2430	2500
2x12	19.2	1240	1340	1440	1530	1620	1710	1800	1880	1970	2050	2130	2200	2280	2360	2430	2500
		1340	1440	1550	1650	1750	1840	1940	2030	2120	2200	2280	2370	2460	2540	2620	2700
	24.0	1340	1440	1550	1650	1750	1840	1940	2030	2120	2200	2280	2370	2460	2540	2620	2700
	24.0	1340	1440	1550	1650	1750	1840	1940	2030	2120	2200	2280	2370	2460	2540	2620	2700

Note: The required extreme fiber stress in bending, "F<sub>b</sub>", in pounds per square inch is shown below each span.

**TABLE TS-2**  
**TWO-SPAN FLOOR JOISTS**  
30 Lbs. Per Sq. Ft. Live Load  
(Optional table for attic floors)

**DESIGN CRITERIA:**  
Deflection - For 30 lbs. per sq. ft. live load on one span and 15 lbs. per sq. ft. on other Limited to span in inches divided by 360.  
Strength - Live load of 30 lbs. per sq. ft. plus dead load of 10 lbs. per sq. ft. on both spans determines the required fiber stress value.

JOIST SIZE SPACING (IN)	Modulus of Elasticity, "E", in 1,000,000 psi															
	0.8	0.9	1.0	1.1	1.2	1.3	1.4	1.5	1.6	1.7	1.8	1.9	2.0	2.2	2.4	2.6
12.0	11.4	11.9	12.2	12.7	13.0	13.4	13.8	14.0	14.3	14.7	14.10	15.1	15.5	15.8	15.70	16.1
	10.30	11.10	11.90	12.70	13.40	14.20	14.90	15.60	16.30	17.00	17.60	18.30	18.90	19.50	20.10	20.70
13.7	10.10	11.3	11.8	12.0	12.5	12.9	13.1	13.4	13.8	13.11	14.2	14.5	14.8	14.11	15.2	15.5
	10.70	11.60	12.50	13.30	14.10	14.80	15.60	16.30	17.00	17.70	18.40	19.10	19.70	20.40	21.00	21.70
16.0	10.3	10.8	11.1	11.5	11.9	12.1	12.5	12.8	13.0	13.3	13.6	13.9	14.0	14.2	14.5	14.8
	11.30	12.20	13.10	14.00	14.80	15.60	16.40	17.20	17.90	18.70	19.40	20.10	20.80	21.50	22.10	22.80
19.2	9.8	10.1	10.5	10.9	11.1	11.5	11.8	11.11	12.2	12.5	12.8	12.11	13.2	13.4	13.7	13.9
	12.00	13.00	13.90	14.80	15.70	16.60	17.40	18.20	19.00	19.80	20.60	21.90	22.10	22.80	23.50	24.20
24.0	9.0	9.4	9.8	10.0	10.3	10.7	10.10	11.1	11.4	11.7	11.9	12.0	12.2	12.5	12.7	12.9
	12.90	14.00	15.00	16.00	16.90	17.90	18.60	19.60	20.50	21.50	22.20	23.00	23.80	24.60	25.30	26.10
12.0	14.11	15.6	16.1	16.7	17.1	17.7	18.0	18.5	18.10	19.2	19.7	19.11	20.3	20.7	20.11	21.3
	10.30	11.10	11.90	12.70	13.50	14.20	14.90	15.60	16.30	17.00	17.60	18.30	18.90	19.50	20.10	20.70
13.7	14.3	14.10	15.5	15.11	16.4	16.10	17.3	17.7	18.0	18.4	18.9	19.1	19.5	19.9	20.0	20.4
	10.80	11.60	12.50	13.30	14.10	14.80	15.60	16.30	17.00	17.70	18.40	19.10	19.80	20.40	21.10	21.70
16.0	13.7	14.1	14.7	15.1	15.6	15.11	16.4	16.3	17.1	17.5	17.9	18.1	18.5	18.9	19.0	19.4
	11.30	12.20	13.10	14.00	14.80	15.60	16.40	17.20	17.90	18.70	19.40	20.10	20.80	21.50	22.20	22.80
19.2	11.9	13.3	13.9	14.2	14.7	15.0	15.5	15.9	16.1	16.5	16.9	17.0	17.4	17.7	17.11	18.2
	12.00	13.00	13.90	14.80	15.70	16.60	17.40	18.30	19.10	19.80	20.60	21.40	22.10	22.80	23.50	24.30
24.0	11.10	12.4	12.9	13.2	13.7	13.11	14.3	14.7	14.11	15.3	15.6	15.10	16.1	16.4	16.7	16.10
	12.90	14.00	15.00	16.00	16.90	17.90	18.80	19.70	20.50	21.40	22.20	23.00	23.80	24.60	25.40	26.10



Appendix

2x10	19-1	19-10	20-6	21-2	21-10	22-5	23-0	23-6	24-0	24-6	25-0	25-5	25-11	26-4	26-9	27-1
	1030	1110	1190	1270	1350	1420	1490	1560	1630	1700	1760	1830	1890	1950	2010	2070
	18-3	19-0	19-8	20-3	20-11	21-5	22-0	22-6	23-0	23-5	23-11	24-4	24-9	25-2	25-7	25-11
	1080	1160	1250	1330	1410	1480	1560	1630	1700	1770	1840	1910	1980	2040	2110	2170
2x12	17-4	18-0	18-8	19-3	19-10	20-4	20-11	21-4	21-10	22-3	22-8	23-1	23-6	23-11	24-3	24-8
	1120	1220	1310	1400	1480	1560	1640	1720	1790	1879	1940	2010	2080	2150	2220	2280
	18-4	18-11	17-7	18-1	18-8	19-2	19-8	20-1	20-6	20-11	21-4	21-9	22-1	22-6	22-10	23-2
	1200	1300	1390	1490	1570	1660	1740	1830	1910	1980	2060	2140	2210	2280	2350	2430
24.0	15-1	15-9	16-4	16-10	17-4	17-9	18-3	18-8	19-1	19-5	19-10	20-2	20-6	20-11	21-2	21-6
	1290	1400	1500	1600	1690	1790	1880	1970	2050	2140	2220	2300	2380	2460	2540	2610
	23-2	24-1	25-0	25-10	26-7	27-3	27-11	28-7	29-3	29-10	30-5	30-11	31-6	32-0	32-6	33-0
	1030	1110	1190	1270	1350	1420	1490	1560	1630	1700	1760	1830	1890	1950	2010	2070
13.7	22-2	23-1	23-11	24-8	25-5	26-1	26-9	27-4	27-11	28-6	29-1	29-7	30-1	30-7	31-1	31-7
	1080	1160	1250	1330	1410	1480	1560	1630	1700	1770	1840	1910	1980	2040	2110	2170
	21-1	21-11	22-8	23-5	24-1	24-9	25-5	26-0	26-7	27-1	27-7	28-1	28-7	29-1	29-6	30-0
	1130	1220	1310	1400	1480	1560	1640	1720	1790	1870	1940	2010	2080	2150	2220	2280
16.0	19-10	20-7	21-4	22-1	22-8	23-4	23-11	24-5	25-0	25-6	26-0	26-6	26-11	27-4	27-9	28-2
	1300	1390	1480	1570	1660	1740	1830	1910	1980	2060	2140	2210	2280	2350	2430	2480
	18-6	19-2	19-10	20-6	21-1	21-8	22-2	22-8	23-2	23-8	24-2	24-7	25-0	25-5	25-10	26-2
	1290	1400	1500	1600	1690	1790	1880	1970	2050	2140	2220	2300	2380	2460	2540	2610

Note: The required extreme fiber stress in bending, "F<sub>b</sub>", in pounds per square inch is shown below each span.

DESIGN VALUES FOR JOISTS AND RAFTERS - VISUAL GRADING

These "F<sub>b</sub>" values are for use where repetitive members are spaced not more than 24 inches. For wider spacing, the "F<sub>b</sub>" values should be reduced 13 percent.

Values for surfaced dry or surfaced green lumber apply at 19 percent maximum moisture content in use.

Species and Grade	Size	Design Value in Bending "F <sub>b</sub> "		Modulus of Elasticity "E"	Grading Rules Agency
		Joists	Rafters		
BALSAM FIR (Surfaced dry or surfaced green)					
Select Structural	2x4	2000	2100	1,500,000	Northeastern Lumber Manufacturers Association
No. 1		1700	1790	1,500,000	
No. 2		1400	1470	1,300,000	
No. 3		775	810	1,200,000	
Appearance		1700	1790	1,500,000	
Stud		775	810	1,200,000	Northern Hardwood & Pine Manufacturers Association
Construction	2x4	1000	1050	1,200,000	
Standard		575	600	1,200,000	
Utility		275	290	1,200,000	
Select Structural	2x5 and wider	1700	1790	1,500,000	(See notes 1 and 3)
No. 1 & Appearance		1450	1520	1,500,000	
No. 2		1200	1260	1,300,000	
No. 3		700	740	1,200,000	
Stud		700	740	1,200,000	

DOUGLAS FIR - LARCH (Surfaced dry or surfaced green)					
Dense Select Structural		2800	2940	1,900,000	
Select Structural		2400	2520	1,800,000	
Dense No. 1		2400	2520	1,900,000	
No. 1 & Appearance	2x4	2050	2150	1,800,000	
Dense No. 2		1950	2050	1,700,000	
No. 2		1650	1730	1,700,000	
No. 3		925	970	1,500,000	
Stud		925	970	1,500,000	
Construction		1200	1260	1,500,000	
Standard	2x4	675	710	1,500,000	
Utility		325	340	1,500,000	
Dense Select Structural		2400	2520	1,900,000	
Select Structural		2050	2150	1,800,000	
Dense No. 1	2x5	2050	2150	1,900,000	
No. 1 & Appearance	and wider	1750	1840	1,800,000	
Dense No. 2		1700	1790	1,700,000	
No. 2		1450	1520	1,700,000	
No. 3		850	890	1,500,000	
Stud		850	890	1,500,000	

Western Wood  
Products  
Association  
(See notes 1  
and 3)

West Coast  
Lumber  
Inspection  
Bureau

DESIGN VALUES FOR JOISTS AND RAFTERS - VISUAL GRADING (Cont)

These "F<sub>b</sub>" values are for use where repetitive members are spaced not more than 24 inches. For wider spacing, the "F<sub>b</sub>" values should be reduced 13 percent.

Values for surfaced dry or surfaced green lumber apply at 19 percent maximum moisture content in use.

Species and Grade	Size	Design Value in Bending "F <sub>b</sub> "		Modulus of Elasticity "E"	Grading Rules Agency
		Joists	Rafters		
EASTERN HEMLOCK (Surfaced dry or surfaced green)					
Select Structural		2050	2150	1,200,000	Northern Hardwood & Pine Manufacturers Association  Northeastern Lumber Manufacturers Association  (See notes 1 and 3)
No. 1	2x4	1750	1840	1,200,000	
No. 2		1450	1520	1,100,000	
No. 3		800	840	1,000,000	
Appearance		1750	1840	1,200,000	
Stud		800	840	1,000,000	
Construction		1050	1100	1,000,000	
Standard	2x4	575	600	1,000,000	
Utility		275	290	1,000,000	
Select Structural	2x5 and wider	1750	1840	1,200,000	
No. 1 & Appearance		1500	1580	1,200,000	
No. 2		1250	1310	1,100,000	
No. 3		700	740	1,000,000	
Stud		700	740	1,000,000	

Register, March, 1992, No. 435

EASTERN SPRUCE (Surfaced dry or surfaced green)					
Select Structural		1600	1680	1,500,000	Northeastern Lumber Manufacturers Association
No. 1		1350	1420	1,500,000	
No. 2	2x4	1100	1160	1,400,000	
No. 3		625	660	1,200,000	
Appearance		1350	1420	1,500,000	Northern Hardwood
Stud		625	660	1,200,000	
Construction		800	840	1,200,000	& Pine Manufacturers Association
Standard	2x4	450	470	1,200,000	
Utility		225	240	1,200,000	
Select Structural		1350	1420	1,500,000	(See notes 1 and 3)
No. 1 & Appearance	2x5	1150	1210	1,500,000	
No. 2	and	950	1000	1,400,000	
No. 3	wider	550	580	1,200,000	
Stud		550	580	1,200,000	

DESIGN VALUES FOR JOISTS AND RAFTERS - VISUAL GRADING (Cont)

These "F<sub>b</sub>" values are for use where repetitive members are spaced not more than 24 inches. For wider spacing, the "F<sub>b</sub>" values should be reduced 13 percent.

Values for surfaced dry or surfaced green lumber apply at 19 percent maximum moisture content in use.

Species and Grade	Size	Design Value in Bending "F <sub>b</sub> "		Modulus of Elasticity "E"	Grading Rules Agency
		Joists	Rafters		
EASTERN WHITE PINE (Surfaced dry or surfaced green)					
Select Structural	2x4	1550	1630	1,200,000	Northeastern Lumber Manufacturers Association
No. 1 & Appearance		1350	1420	1,200,000	
No. 2		1100	1160	1,100,000	
No. 3		600	630	1,000,000	
Stud		600	630	1,000,000	
Construction					
Standard	2x4	800	840	1,000,000	Northern Hardwood & Pine Manufacturers Association
Utility		450	470	1,000,000	
		200	210	1,000,000	
Select Structural	2x5 and wider	1350	1420	1,200,000	(See notes 1 and 3)
No. 1 & Appearance		1150	1210	1,200,000	
No. 2		950	1000	1,100,000	
No. 3		550	580	1,000,000	
Stud		550	580	1,000,000	

EASTERN WHITE PINE (NORTH) (Surfaced dry or surfaced green)					Nat'l. Lumber Grades Auth. (A Canadian Agency - See notes 1, 2 and 3)
Select Structural		1550	1630	1,200,000	
No. 1 & Appearance		1350	1420	1,200,000	
No. 2	2x4	1100	1160	1,100,000	
No. 3		600	630	1,000,000	
Stud		600	630	1,000,000	
Construction		800	840	1,000,000	
Standard	2x4	450	470	1,000,000	
Utility		200	210	1,000,000	
Select Structural	2x5	1350	1420	1,200,000	
No. 1 & Appearance	and	1150	1210	1,200,000	
No. 2	wider	950	1000	1,100,000	
No. 3		550	580	1,000,000	
Stud		550	580	1,000,000	

DESIGN VALUES FOR JOISTS AND RAFTERS - VISUAL GRADING (Cont)

These "F<sub>b</sub>" values are for use where repetitive members are spaced not more than 24 inches. For wider spacing, the "F<sub>b</sub>" values should be reduced 13 percent.

Values for surfaced dry or surfaced green lumber apply at 19 percent maximum moisture content in use.

Species and Grade	Size	Design Value in Bending "F <sub>b</sub> "		Modulus of Elasticity "E"	Grading Rules Agency
		Joists	Rafters		
HEM - FIR (Surfaced dry or surfaced green)					
Select Structural	2x4	1900	2000	1,500,000	Western Wood Products Association (See notes 1 and 3)
No. 1 & Appearance		1600	1680	1,500,000	
No. 2		1350	1420	1,400,000	
No. 3		725	760	1,200,000	
Stud		725	760	1,200,000	
Construction	2x4	975	1020	1,200,000	West Coast Lumber Inspection Bureau
Standard		550	580	1,200,000	
Utility		250	260	1,200,000	
Select Structural	2x5 and wider	1650	1730	1,500,000	Lumber Inspection Bureau
No. 1 & Appearance		1400	1470	1,500,000	
No. 2		1150	1210	1,400,000	
No. 3		675	710	1,200,000	
Stud		675	710	1,200,000	



NORTHERN PINE (Surfaced dry or surfaced green)					
Select Structural		1850	1940	1,400,000	Northeastern Lumber Manufacturers Association
No. 1	2x4	1600	1680	1,400,000	
No. 2		1300	1370	1,300,000	
No. 3		725	760	1,100,000	
Appearance		1400	1470	1,400,000	
Stud		725	760	1,100,000	Northern Hardwood & Pine Manufacturers Association
Construction		950	1000	1,100,000	Northern Hardwood & Pine Manufacturers Association
Standard	2x4	525	550	1,100,000	
Utility		250	260	1,100,000	
Select Structural		1600	1680	1,400,000	(See notes 1 and 3)
No. 1 & Appearance	2x5	1400	1470	1,400,000	
No. 2		and	1100	1160	
No. 3	wider	650	680	1,100,000	
Stud		650	680	1,100,000	

DESIGN VALUES FOR JOISTS AND RAFTERS - VISUAL GRADING (Cont)

These "F<sub>b</sub>" values are for use where repetitive members are spaced not more than 24 inches. For wider spacing, the "F<sub>b</sub>" values should be reduced 13 percent.

Values for surfaced dry or surfaced green lumber apply at 19 percent maximum moisture content in use.

Species and Grade	Size	Design Value in Bending "F <sub>b</sub> "		Modulus of Elasticity "E"	Grading Rules Agency
		Joists	Rafters		
PONDEROSA PINE - SUGAR PINE (PONDEROSA PINE - LODGEPOLE PINE) (Surfaced dry or surfaced green)					
Select Structural	2x4	1650	1730	1,200,000	Western Wood Products Association  (See notes 1 and 3)
No. 1 & Appearance		1400	1470	1,200,000	
No. 2		1150	1210	1,100,000	
No. 3		625	660	1,000,000	
Stud	625	660	1,000,000		
Construction	2x4	825	870	1,000,000	
Standard		450	470	1,000,000	
Utility		225	240	1,000,000	
Select Structural	2x5 and wider	1400	1470	1,200,000	
No. 1 & Appearance		1200	1260	1,200,000	
No. 2		975	1020	1,100,000	
No. 3		575	600	1,000,000	
Stud	575	600	1,000,000		

SOUTHERN PINE (Surfaced dry)					Southern Pine Inspection Bureau  (See note 3)
Select Structural		2300	2420	1,700,000	
Dense Select Structural		2700	2840	1,800,000	
No. 1		1950	2050	1,700,000	
No. 1 Dense		2300	2420	1,800,000	
No. 2	2x4	1650	1730	1,600,000	
No. 2 Dense		1900	2000	1,600,000	
No. 3		900	950	1,400,000	
No. 3 Dense		1050	1100	1,500,000	
Stud		900	950	1,400,000	
<hr/>					
Construction		1150	1210	1,400,000	
Standard	2x4	675	710	1,400,000	
Utility		300	320	1,400,000	
<hr/>					
Select Structural		2000	2100	1,700,000	
Dense Select Structural		2350	2470	1,800,000	
No. 1		1700	1790	1,700,000	
No. 1 Dense		2000	2100	1,800,000	
No. 2	2x5 and wider	1400	1470	1,600,000	
No. 2 Dense		1650	1730	1,600,000	
No. 3		800	840	1,400,000	
No. 3 Dense		925	970	1,500,000	
Stud		850	890	1,400,000	

DESIGN VALUES FOR JOISTS AND RAFTERS - VISUAL GRADING (Cont)

These "F<sub>b</sub>" values are for use where repetitive members are spaced not more than 24 inches. For wider spacing, the "F<sub>b</sub>" values should be reduced 13 percent. Values for surfaced dry or surfaced green lumber apply at 19 percent maximum moisture content in use.

Species and Grade	Size	Design Value in Bending "F <sub>b</sub> "		Modulus of Elasticity "E"	Grading Rules Agency
		Joists	Rafters		
SOUTHERN PINE (Surfaced at 15 percent maximum moisture content-KD)					
Select Structural		2500	2630	1,800,000	Southern Pine Inspection Bureau
Dense Select Structural		2900	3050	1,900,000	
No. 1		2100	2210	1,800,000	
No. 1 Dense		2450	2570	1,900,000	
No. 2	2x4	1750	1840	1,600,000	
No. 2 Dense		2050	2150	1,700,000	
No. 3		975	1020	1,500,000	
No. 3 Dense		1150	1210	1,500,000	
Stud		975	1020	1,500,000	
Construction Standard	2x4	1250	1310	1,500,000	
Utility		725	760	1,500,000	
Utility		300	320	1,500,000	
Select Structural		2150	2260	1,800,000	
Dense Select Structural		2500	2630	1,900,000	
No. 1		1850	1940	1,800,000	
No. 1 Dense	2x5 and wider	2150	2260	1,900,000	
No. 2		1500	1580	1,600,000	
No. 2 Dense		1750	1840	1,700,000	
No. 3		875	920	1,500,000	
No. 3 Dense		1000	1050	1,500,000	
Stud		900	950	1,500,000	

SPRUCE - PINE - FIR (Surfaced dry or surfaced green) Select Structural No. 1 & Appearance No. 2 No. 3 Stud  Construction Standard Utility  Select Structural No. 1 & Appearance No. 2 No. 3 Stud	1650	1730	1,500,000	Nat'l. Lumber Grades Auth. Agency - (A Canadian Agency - (See notes 1, 2 and 3)
	1400	1470	1,500,000	
	2x4	1210	1,300,000	
		650	1,200,000	
		650	1,200,000	
	2x4	850	1,200,000	
		475	1,200,000	
		225	1,200,000	
	2x5 and w/6set	1450	1,500,000	
		1200	1,500,000	
		1000	1,300,000	
		575	1,200,000	
	575	1,200,000		

DESIGN VALUES FOR JOISTS AND RAFTERS - VISUAL GRADING (Cont)

These "F<sub>b</sub>" values are for use where repetitive members are spaced not more than 24 inches. For wider spacing, the "F<sub>b</sub>" values should be reduced 13 percent.

Values for surfaced dry or surfaced green lumber apply at 19 percent maximum moisture content in use.

Species and Grade	Size	Design Value in Bending "F <sub>b</sub> "		Modulus of Elasticity "E"	Grading Rules Agency
		Joists	Rafters		
WESTERN HEMLOCK (Surfaced dry or surfaced green)					
Select Structural	2x4	2100	2210	1,600,000	Western Wood Products Association (See notes 1 and 3)
No. 1 & Appearance		1800	1890	1,600,000	
No. 2		1450	1520	1,400,000	
No. 3		800	840	1,300,000	
Stud		800	840	1,300,000	
Construction Standard	2x4	1050	1100	1,300,000	West Coast Lumber Inspection Bureau
Utility		600	630	1,300,000	
		275	290	1,300,000	
Select Structural	2x5 and wider	1800	1890	1,600,000	
No. 1 & Appearance		1550	1630	1,600,000	
No. 2		1250	1310	1,400,000	
No. 3		750	790	1,300,000	
Stud		750	790	1,300,000	

## Appendix

WHITE WOODS (WESTERN WOODS) (Surfaced dry or surfaced green)					
Select Structural No. 1 & Appearance	2x4	1550	1630	1,100,000	Western Wood Products Association  (See notes 1 and 3)
No. 2		1300	1370	1,100,000	
No. 3		1050	1100	1,000,000	
Stud		600	630	900,000	
Construction Standard	2x4	775	810	900,000	
Utility		425	450	900,000	
		200	210	900,000	
Select Structural No. 1 & Appearance	2x5 and wider	1300	1370	1,100,000	
No. 2		1100	1160	1,100,000	
No. 3		925	970	1,000,000	
Stud		550	580	900,000	
		550	580	900,000	

1. When 2-inch lumber is manufactured at a maximum moisture content of 15% (grade marked MC-15) and used in a condition where the moisture content does not exceed 15%, the design values shown for "surfaced dry or surfaced green" lumber may be increased 8% for design value in bending "F<sub>b</sub>", and 5% for modulus of elasticity "E".

2. National Lumber Grades Authority is the Canadian rules writing agency responsible for preparation, maintenance and dissemination of a uniform softwood lumber grading rule for all Canadian species.

3. Design values for stud grade in 2x5 and wider size classifications apply to 5-inch and 6-inch widths only.

APPENDIX A  
CHAPTER ILHR 22  
DETERMINATION OF REQUIRED LEVELS OF INSULATION  
USING THE ENERGY WORKSHEET

Two methods may be used to determine the level of insulation required by Chapter ILHR 22 for electrically heated and non-electrically heated dwellings. The Component Method (also known as the Accepted Practice Method) can be used with a minimum of calculations and is recommended for standard designs. The System Design Method is more complex and is used for alternate designs. Under the System Design Method, less insulation may be installed in one building component if more insulation is installed in another.

The following illustration demonstrates use of the Energy Worksheet to determine the required levels of insulation. Single copies of the Energy Worksheet are available at no charge upon written request.

Write to:

Department of Industry, Labor and Human Relations  
Division of Safety and Buildings  
Post Office Box 7969  
Madison, Wisconsin 53707

Portions A and H of the Energy Worksheet must be filled out for the Component Method. Portions B, C and D of the Energy Worksheet must be filled out to use the System Design Method. Sections B and F are filled out to size the furnace for either method. Section G must be filled out to size the ventilation system for electrically heated homes. Both the Component Method and the System Method will be shown in the illustration, although completion of only one method is sufficient to show compliance with the insulation requirements of Ch. ILHR 22.

SAMPLE DWELLING

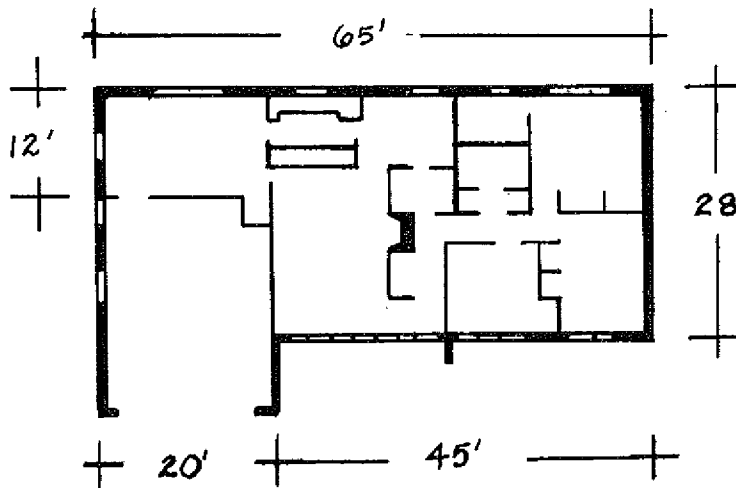



## Appendix

Sample dwelling: 1,500 square feet 186 lineal feet of perimeter building thermal envelope.

Gross wall area = 8.13 feet × 186 lineal feet = 1,512.18 square feet  
 Wall window area = 172.67 square feet  
 Box sill area = 0.81 feet × 186 lineal feet = 150.66 square feet  
 Gross exposed foundation wall area = 124.62 square feet  
 Basement window area = 15.65 square feet  
 Door area = 37.82 square feet  
 Ceiling area = 1,500 square feet

Dane County location - Zone 3

The dwelling will be electrically heated.

The planned construction:

## Walls

Wood bevel ½" × 8" siding	R = 0.81
1" Extruded polystyrene sheathing	R = 5.27
R19 Batt insulation	R = 19
2 × 6 Framing, 24" O.C.	R = 6.875
Drywall ½"	R = 0.45

## Ceiling

2 × 6 Framing, 24" O.C.	R = 6.875
Blown Fiberglass insulation	R/inch = 2.5
Insulation in 5.5" Cavity	R = 13.75
Insulation over both Cavity and Framing, 14.5"	R = 36.25
½-inch drywall finish	R = 0.45

## Foundation

8" Masonry Block	R = 1.72
2" Extruded polystyrene	R = 10.54

## Windows

All triple glazed	R = 2.7
-------------------	---------

## Doors

Insulated	R = 2.12
Storm door	R = 1.00
Total door R value	R = 3.12

The 1500 square foot basement will be divided into a 575 square foot finished living space and a 925 square foot utility and storage space. The value of all the dead air spaces on both levels (closets, cabinets, interior walls, etc.) equals 2163 cubic feet.

*Estimating Design R-values for Building Materials and Components*

R-values listed in Table A-4 of the UDC appendix, ASHRAE manual or manufacturer's specifications may be helpful in determining the designed R-values for building components or materials. The designed R-values which are entered in Part C of the Energy Worksheet should be consistent with the end use or installed condition of the insulation and building materials used. The design R-values should take into account possible effects such as:

- Long term aging effects.

- Settling or other density variations that may occur with blown-in fiberglass and cellulose insulation.
- Moisture effect on wet installations such as exterior foundation insulation.
- Effect of compression on insulating materials subject to loads, such as the case of porous, semi-ridged fiberglass applied to foundation exteriors.
- Orientation of installation effects (horizontal or vertical).

In order to use the design R-value given in the manufacturer's specifications, insulation and building materials must be installed in accordance with the manufacturer's instructions. For example, most foam panel insulation products are required to be protected from exposure to sunlight (ultraviolet light). An opaque covering is typically installed to provide that protection.

**DILHR**

Safety and Buildings Division  
P.O. Box 7969  
Madison, WI 53707

**ENERGY WORKSHEET**  
**UNIFORM DWELLING CODE**

PROJECT ADDRESS: SAMPLE - ZONE 3

BUILDER: \_\_\_\_\_ OWNER: \_\_\_\_\_

WORKSHEET COMPLETED BY: \_\_\_\_\_ DATE: \_\_\_\_\_

Does dwelling unit have three kilowatts or more input capacity of permanently installed electrical space heating equipment?

YES (see below)     NO

If yes, then indicate infiltration control option:

Full sealing per s. ILHR 22.13(3)(a)  
 Infiltration barrier per s. ILHR 22.13(3)(b)  
 Blower door test per s. ILHR 22.13(2)(c) & (3)(c)

**INSTRUCTIONS:** This worksheet is a DILHR-approved method of showing compliance with the energy conservation standards of Chapter ILHR 22 of the Uniform Dwelling Code (UDC) which applies to one- and two-family dwellings built since December 1, 1978. It is recommended that the user purchase a copy of the UDC from State Document Sales, (608) 266-3358.

You have the choice of using the Accepted Practice Method or the System Design Method to show code compliance. For the Accepted Practice Method, which is recommended for standard designs, complete Sections A. and B. and Sections E. through F. and Section H. You will be first calculating component areas, then your dwelling's code-allowed and other heat loss to determine your furnace size, and then comparing your planned insulation levels to the required insulation levels from the Appendix of the UDC.

For the System Design Method, which is recommended for alternative designs, complete Sections A. through F. You will be first calculating component areas, then the code-allowed heat loss, then component U- and R-values and then your calculated heat loss which you will compare to the code-allowed heat loss. You will also be calculating the allowable furnace size.

With either method, you will need to apply the stricter and slightly different standards shown for electrically-heated homes if you answered "YES" to the above question. For electrically heated homes, you must also complete Section G. to determine the required mechanical ventilation capacity.

All "R" and "U" calculations must be carried to four places after the decimal point, rounded to three places. Linear dimensions must be carried to three places, rounded to two. Area and heat loss calculations may be rounded to the whole number.

Numbers in brackets, [1], refer to the footnotes listed on page 5.

590-5518 (Rev. 1-88)

**A. AREA CALCULATIONS**

Some calculations will not be necessary depending on home design and heating fuel. These calculated areas are referenced elsewhere on this worksheet, for example, A.1., A.2. \_\_\_\_\_

<p>1. GROSS (INSULATED) ABOVE-FOUNDATION WALL AREA (including doors, windows and box/sills)</p> <p>1512.18 + 150.66 =</p> <p>1662.84 sq. ft.</p>	<p>4. GROSS EXPOSED FOUNDATION WALL AREA (Enclosing warm space 50° F or warmer)</p> <p>124.62 sq. ft.</p>	
<p>2. WINDOW &amp; PATIO DOOR AREA (slab/door area)</p> <p>a. In Above-Foundation Walls      b. In Foundation Walls</p> <p>172.67 sq. ft.      15.65 sq. ft.</p> <p>Total (a. + b.) = 188.32</p>	<p>5. FOUNDATION WALL AREA BETWEEN GRADE AND THREE FEET BELOW GRADE</p> <p>186 x 3 =</p> <p>558.0 sq. ft.</p>	
<p>3. DOOR AREA IN ABOVE-FOUNDATION WALLS</p> <p>37.82 sq. ft.</p>	<p>6. FOUNDATION WALL AREA MORE THAN THREE FEET BELOW GRADE</p> <p>805.38 sq. ft.</p>	
<p>7. OPAQUE [1] ABOVE-FOUNDATION WALL AREA (1.-2.a.-3.)</p> <p>1662.84 - 172.67 - 37.82 =</p> <p>1452.35 sq. ft.</p>	<p>8. GROSS WALL AREA ABOVE GRADE (1. + 4)</p> <p>1662.84 + 124.62 =</p> <p>1787.46 sq. ft.</p>	<p>9. OPAQUE [1] EXPOSED FOUNDATION WALL AREA (4.-2.b)</p> <p>124.62 - 15.65 =</p> <p>108.97 sq. ft.</p>
<p>10. WALL AREA BELOW GRADE (5. + 6)</p> <p>558.0 + 805.38 =</p> <p>1363.38 sq. ft.</p>	<p>11. TOTAL FOUNDATION WALL AREA (4. + 5. + 6)</p> <p>124.62 + 558.0 + 805.38 =</p> <p>1488.0 sq. ft.</p>	<p>12. INSULATED ROOF OR CEILING AREA</p> <p>1500 sq. ft.</p>
<p>13. FLOOR AREA OVER UNHEATED SPACES (LESS THAN 50°)</p> <p>0 sq. ft.</p>	<p>14. SLAB ON GRADE (slab-on-grade garage will be placed outside the thermal envelope)</p> <p>0 lineal feet of slab perimeter</p>	<p>15. BASEMENT FLOOR AREA</p> <p>1500 sq. ft.</p>

B. CODE-ALLOWED HEAT LOSS

PAGE 3

Enter values into table from elsewhere on this worksheet and multiply across by the electric or non-electric code-required U-value. For lines 1 through 5 for walls, complete as follows:

Electrically-heated Homes - Lines 1, 4 & 5.

Non-Electrically Heated Homes - Option A or B.

Option A - Lines 1, 4 & 5 - Suggested if non-foundation and exposed foundation walls are of similar construction.

Option B - Lines 2, 3, 4 and 5.

COMPONENT	AREA FROM SECT. A	REQUIRED U-VALUE		TEMP. DIFF. (°F)	HEAT LOSS BTU/HR
		NON-ELECTRIC	ELECTRIC		
1. Gross Wall Above Grade (A.8)	1787.46	.13	.080	85	12155
2. Gross Above-Foundation Wall (A.1)		.12	N/A		
3 a. Gross Exposed Foundation Wall (A.4) Max Area of A.4 ÷ A.11 = .25		.25	N/A		
b. Gross Exposed Foundation Wall in Excess of Line 3 a.		.12	N/A		
4. Foundation Wall Between Grade And 3 Feet Below Grade (A.5)	558.0	.113 [3]	.072 [3]	60	2411
5. Foundation Wall More Than Three Feet Below Grade (A.6)	805.38	.094 [3]	.028 [3]	60	2320
6. Floors Over Unheated Spaces (A.13)	0	.09	.055	85	0
7. Roof or Ceiling (A.12)	1500	.029	.020	85	2550
8. Slab On Grade (A.14)	0 Lin. ft.	.51 'F' [4]	.51 'F' [4]	85	0
9. Basement Floor (A.15)	1500	.025	.025	60	2250
<b>TOTAL CODE-ALLOWED HEAT LOSS</b>					<b>21686</b>

C. SYSTEM DESIGN METHOD - ACTUAL 'U' VALUES OF YOUR HOME

C.1. ABOVE-GRADE COMPONENTS - Enter 'R-values' from Table A.4 of the UOC Appendix, ASHRAE Manual, or manufacturer's specifications. Total them across and then find the 'U' value by taking the reciprocal (1/R) of the total 'R-value'. For components having the same insulation but different interior or exterior finishes, separate calculations are not necessary if the one with the lowest 'R-value' is used in your calculations.

COMPONENT	CAVITY OR SOLID W/ APPLICABLE	EXT. AIR FILM *	EXT. FINISH	SHEATHING	INSULATION OVER FRAMING	FRAMING OR SOLID	INSULATION IN CAVITY	INTERIOR FINISH	INT. AIR FILM *	TOTAL 'R-VALUE'	'U-Value' (or 1/R)
Above-Foundation Walls	Cavity Solid	.17	.81	5.27	0		19	0.45	.68	26.38	0.038
Exposed Foundation	Cavity Solid	.17	.81	5.27	0	6.88		0.45	.68	14.26	0.070
Roof or Ceiling	Cavity Solid	.61		10.54		1.72	13.75	0.45	.61	13.11	0.076
Floor Over Unheated Space	Cavity Solid	.17		36.25	36.25	6.88		0.45	.61	51.57	0.019
									.92		

\* Air Film R-Values

LOCATION	HEAT FLOW DIRECTION		
	Upwards	Horizontal	Downwards
EXTERIOR	.17	.17	.17
INTERIOR	.61	.68	.92

C2. BELOW-GRADE COMPONENTS - Precalculated 'U-values' including air films, wall, insulation and soil. Check appropriate boxes for planned type of construction.

COMPONENT TYPE	GRADE TO THREE FEET BELOW GRADE	MORE THAN THREE FEET BELOW GRADE
<input type="checkbox"/> Masonry or conc. wall without insulation	.288	.094
<input type="checkbox"/> Masonry or conc. wall with R-5 insulation board	.113	.063
<input type="checkbox"/> Masonry or conc. wall with R-10 insulation board or R-11 insulation batt and 2x4's	.072	.048
<input type="checkbox"/> Basement floor without insulation	.025	.025
<input type="checkbox"/> Basement floor with R-5 insulation	.022	.022
<input type="checkbox"/> Slab-on-Grade or within 2 ft of grade without insulation	.81 (F-value) per/lineal foot of slab perimeter	
<input type="checkbox"/> Slab-on-Grade or within 2 ft of grade with R-10 insulation board for 48" total horizontal and vertical application	.51 (F-value) per/lineal foot of slab perimeter	
<input type="checkbox"/> Other (describe)	Claimed U-value:	Claimed U-value:

C3. WINDOWS AND DOORS - See Tables A-5 and A-6 of UDC Appendix for U-values and wood frame factors.

D. SYSTEM DESIGN METHOD - CALCULATED ENVELOPE HEAT LOSS OF YOUR HOME

Enter values into table from elsewhere on this worksheet and multiply across to find the actual heat loss of each component. Add component heat loss figures to find total envelope heat loss.

COMPONENT	CAVITY OR SOLID IF APPLICABLE	AREA FROM SECT. A.	WOOD FRAME FACTOR**	ACTUAL U VALUE FROM SECT. C.	TEMP. DIFF. (°)	HEAT LOSS BTU/HR
Opaque Above-Foundation Wall (A. 7.)	Cavity	1452.35	.90	0.038	85	4222
Opaque Exposed Foundation Wall (A. 9.)	Solid		.10	0.070		864
		108.97		0.076	85	704
Foundation Between Grade and Three Feet Below Grade (A. 5.)		558.0		0.072	60	2411
Foundation Wall More Than Three Feet Below Grade (A. 6.)		805.38		0.048	60	2319
Windows (A. 2. a. + b.)		188.32	.95	0.370	85	5627
Doors (A. 3.)		37.92		0.320	85	1023
Roof or Ceiling (A. 12.)	Cavity	1500.0	.93	0.019	85	2253
	Solid		.07	0.022		196
Floor Over Unheated Spaces (A. 13.)	Cavity					
	Solid					
Basement Floor (A. 15.)		1500.0		0.025	60	2250
Slab On Grade (A. 14.)		Lin. Ft.		F-Val.		
<b>TOTAL CALCULATED ENVELOPE HEAT LOSS - May not exceed Total Code Allowed Heat Loss in Sect. B. by more than 1%.</b>						<b>21875</b>

\*\* Adjustment Factors For Wood-Framed Components

SPACING OF FRAMING MEMBERS	STUDS		JOISTS RAFTERS	
	CAVITY	SOLID	CAVITY	SOLID
12"	.80	.20	.85	.14
16"	.85	.15	.90	.10
24"	.90	.10	.93	.07

Also see Part C of UDC Appendix Table A-5 for window framing adjustment factors.

**E. HEAT LOSS BY AIR INFILTRATION (for furnace sizing)**

An air change rate of between 0.25 and 1.00 per hour is recommended depending on tightness of construction.

FLOOR LEVEL	AREA	X HEIGHT	= VOLUME	X CONSTANT	X TEMPERATURE DIFFERENCE (2)	X AIR CHANGES PER HOUR	= HEAT LOSS 8TU/HR	
Basement	1500		8	12000	.018	85	0.5	9180
Level 1	1500		8	12000	.018	85	0.5	9180
Level 2					.018			
Level 3					.018			
Total Dwelling Volume			24000	INFILTRATION HEAT LOSS				18360

**F. FURNACE SIZING**

This section determines the maximum and minimum furnace size in 8TU'S/HR.

	Minimum	Maximum
System Design Method: Calculated Heat Loss from Sect. D. or Accepted Practice Method: Code-Allowed Heat Loss from Sect. B.	21075	-----
Code-Allowed Heat Loss (from Sect. B.)	-----	21685
Infiltration Heat Loss (from Sect. E.)	+ 18360	+ 18360
TOTAL DWELLING HEAT LOSS (total of above)	= 40235	= 40045
Allowable Furnace Size Margin Multiplier	X 1.0	X 1.15
ALLOWABLE FURNACE OUTPUT SIZE RANGE	= 40235	= 46053 [5]
Planned Furnace Output		50,000

**G. MECHANICAL VENTILATION SIZING**

Required for electrically-heated homes only.

1. Dwelling volume from Sect. E.	=	24,000
2. Less volume of non-living area; area: ( 925 ) X height: ( 8 ) =	=	7,400
3. Less volume of dead air spaces (cabinets, walls, etc) Approx. 20%	=	2,163
4. Net volume of living area (total of above)	=	14,437
5. Cubic feet of air changed per hour (multiply line 4 by 0.5)	=	7,218.5
6. MINIMUM REQUIRED MECHANICAL VENTILATION IN CFM'S (multiply line 5 by 0.0167)	=	120.5

**Footnotes:**

- [1] Opaque wall area is wall area minus opening areas of doors and windows.
- [2] Temperature Difference = inside design temperature of 70° minus outside design temperature from Table 22.04-B of the UDC. Basement inside temperature may be taken between 50° and 70°. Temperature difference for transmission heat losses of below-grade spaces of basements is inside temperature minus 10°, disregarding outside temperature.
- [3] These below-grade U-values have the insulating value of the soil added to the code-required U-values which apply to the building material only. See sect. C.2. for typical insulated component U-values.
- [4] These slab-on-grade R-values are derived from the code-required U-values and include the heat loss through the edge and body of the slab. See sect. C.2.
- [5] If desired manufacturer does not have a furnace of this size, designer may go to manufacturer's next larger size.

**H. ACCEPTED PRACTICE METHOD**

For completion of the accepted practice method, please refer to the Appendix Tables A-1, 2 and 3 and E-1, 2 and 3 of the Uniform Dwelling Code (UDC). Complete Subsection H.1. if your home is heated with other than electricity. Complete Subsection H.2. if your home is electrically heated. Area figures should be calculated in Section A. and are referenced below.

**SUBSECTION H.1. Non-Electrically Heated Homes Only**

WALLS ABOVE FOUNDATION WALL INCLUDING BOX SILL, USE TABLE A-1	MINIMUM <input type="checkbox"/> Single w/storm ABOVE-FDN <input type="checkbox"/> Insulated glass WINDOWS: <input type="checkbox"/> Triple pane	MINIMUM <input type="checkbox"/> Insulated DOORS: <input type="checkbox"/> Solid Wood <input type="checkbox"/> Uninsulated w/storm	SIDING: <input type="checkbox"/> Wood (R-.77) <input type="checkbox"/> Alum. (R-1.82) <input type="checkbox"/> Other: R-_____
	PLANNED INSULATION TYPE AND R-VALUE: _____		PERMITTED WINDOW AND DOOR AREA: _____ %
$\frac{\text{Above Foundation Window \& Door Area (A.2.a. + A.3.)}}{\text{Gross Above-Foundation Wall Area (A.1.)}} \times 100\% =$ _____ %		Planned Window and Door Area	
EXPOSED FOUNDATION WALL, USE TABLE A-2	BASEMENT WINDOWS: <input type="checkbox"/> Single-glazed OR <input type="checkbox"/> Single w/storm or insulated glass		
	PLANNED INSULATION TYPE AND R-VALUE: _____		
	$\frac{\text{Exposed Foundation Area (A.4)}}{\text{Total Foundation Area (A.11.)}} \times 100\% =$ _____ %		% Exposed Foundation
(If over 25% exposed foundation, then exposed foundation area equal to 25% of foundation shall have maximum U-Value of .25 and balance of area shall have maximum U-Value of .12.)			
Percent Window Area Permitted By Table: _____ %			
$\frac{\text{Basement Window Area (A.2.b)}}{\text{Exposed Fdn. Wall Area (A.4)}} \times 100\% =$ _____ %		% Planned Window Area	
ROOF OR CEILING, USE TABLE A-3	PLANNED INSULATION TYPE: _____ R-VALUE PER INCH: _____		
	REQUIRED THICKNESS: _____ Inches in cavity (R-38) _____ Inches Over Framing (R-19)		
FOUNDATION WALL, GRADE TO 3 FEET DOWN	PLANNED INSULATION TYPE AND R-VALUE: _____ (MINIMUM R-5 INSULATION)		

**SUBSECTION H.2. Electrically Heated Homes Only**

WALLS ABOVE FOUNDATION INCLUDING BOX-SILL, USE TABLES E-1 AND E-2	ALL THESE MEASURES REQUIRED: <input checked="" type="checkbox"/> ALL WINDOWS TRIPLE-GLAZED <input checked="" type="checkbox"/> EXPOSED FOUNDATION INSULATED TO R-10.54 <input checked="" type="checkbox"/> DOORS INSULATED TO R-8		
	$\frac{(172.67 + 15.65)}{\text{Total Window Area (A.2.a. + b.)}} + \frac{1787.46}{\text{Above Grade Wall Area (A.8)}} \times 100\% =$ _____ %		% Window Area
	$\frac{108.97}{\text{Opaque Exposed Foundation Area (A.9.)}} + \frac{1787.46}{\text{Above Grade Wall Area (A.8.)}} \times 100\% =$ _____ %		% Opaque Exposed Foundation Wall
	Required Above Foundation Wall U-Value (from Table E-1): 0.044		
	Planned Wall Construction: R 5.27 sheathing U-Value from Table E-2: 0.044		
ROOF OR CEILING, USE TABLE E-3	PLANNED INSULATION TYPE: Blown Fiberglass R-VALUE PER INCH: 2.5		
	REQUIRED THICKNESS FROM TABLE E-3: 20.0 Inches		
FOUNDATION WALL FOR FULL HEIGHT	PLANNED INSULATION TYPE AND R-VALUE: 2" Styrofoam, R = 10.5 (MINIMUM R-10 INSULATION)		



**TABLE A-1**  
**WALL INSULATION GUIDE**

(Based on  $U_o$  requirements above the foundation wall for non-electrically heated dwellings)

INSULATION TYPE	MAXIMUM PERCENT WINDOW AND DOOR AREA ALLOWABLE FOR INSULATION TYPE	
	$U_o = .12$	
	% inch Plywood Siding	Backed Aluminum Siding
R-11 Batt	6.8	8.4
R-11 Batt, R-1.22 Fiberboard	8.7	9.9
R-11 Batt, R-5.27 Extruded Polystyrene	12.4	13.0
R-11 Batt, R-10.54 Extruded Polystyrene	14.9	15.3
R-13 Batt	8.3	9.8
R-13 Batt, R-1.22 Fiberboard	10.3	11.2
R-13 Batt, R-5.27 Extruded Polystyrene	13.1	13.6
R-13 Batt, R-10.54 Extruded Polystyrene	15.3	15.6
R-19 Batt	11.2	12.2
R-19 Batt, R-1.22 Fiberboard	12.3	13.1
R-19 Batt, R-5.27 Extruded Polystyrene	14.7	15.1
R-19 Batt, R-10.54 Extruded Polystyrene	16.3	16.6

Note: The following assumptions were used to derive this table:

1. Door area = 2% of wall and box sill area.
2. Doors are used with a U-value of 0.47.
3. Windows are used with a U-value of 0.56.
4. The insulation type is carried down through the box sill.

**TABLE A-2**  
**EXPOSED FOUNDATION INSULATION**  
**NON-ELECTRICALLY HEATED DWELLINGS**

Foundation Exposure	Requirement	Insulation Type	Maximum Percent Window Area	
			Single glazed	Double glazed
Less than 25% of foundation exposed	$U_o = .25$	R-5.27	10.4	24.8
		R-11 batt	15.5	34.2
		Multi-cell insul. block (R-12.06)	16.0	35.0
More than 25% of foundation exposed	$U_o = .13$	R-11 batt	3.9	8.7
		R-13 batt	4.8	10.6
		Multi-cell insul. block (R-12.06)	4.5	9.9
	$U_o = .12$	R-11 batt	3.0	6.7
		R-13 batt	3.9	8.5
		Multi-cell insul. block (R-12.06)	3.5	7.8

**TABLE A-3**  
**INSULATION LEVELS REQUIRED TO MEET CEILING U VALUES**  
**FOR NON-ELECTRICALLY HEATED DWELLINGS**

U <sub>o</sub> Value	Insulation	R-Value Required	
		In Cavity	Over Framing
.029	Fiber glass batt	R-38	R-19
	Fiber glass blown	13.6 in. (R-34)	8.1 in. (R-20)
	Rock wool	10.9 in. (R-33)	5.4 in. (R-16)
	Cellulose	9.5 in. (R-35)	4.0 in. (R-15)

Note: The following assumptions are used:

1. Fiber glass blown = R-2.5 per inch
2. Rock wool = R-3.0 per inch
3. Cellulose = R-3.7 per inch

**TABLE E-1 - DIRECTIONS FOR USE**

Table E-1 was formulated with the following assumptions:

The doors have R-values of at least R-8 and form 2% or less of the above-foundation wall.

$$\frac{\text{door area}}{\text{gross wall area} + \text{box sill}} \times 100\%, \text{ in this case} =$$

$$\frac{37.82}{1512.18 + 150.66} \times 100\% = 2\%$$

Windows with an R-value of at least 2.7 (triple glazed) are used, including the foundation windows.

The exposed foundation area is insulated to a level of R-10.54.

If these assumptions are not valid for your case, the insulation level may be calculated by the method illustrated following Tables E-1 and E-2.

TABLE E-1

MAXIMUM ABOVE-FOUNDATION WALL U-VALUES FOR  
ELECTRICALLY HEATED HOMES  
PERCENT WINDOW AREA

	5	6	7	8	9	10	11	12	13	14	15	16	
PERCENT	0	.065	.062	.059	.056	.053	.050	.046	.043	.040	.036	.032	.029
	5	.065	.061	.058	.055	.051	.048	.044	.041	.037	.033	.029	.025
	6	.064	.061	.058	.055	.051	.048	.044	.040	.037	.033	.029	.025
	7	.064	.061	.058	.054	.051	.047	.044	.040	.036	.032	.029	
	8	.064	.061	.057	.054	.050	.047	.043	.039	.035	.031	.027	
OPAQUE	9	.064	.061	.057	.054	.050	.046	.043	.039	.035	.031	.027	
	10	.064	.060	.057	.053	.050	.046	.042	.038	.034	.030	.026	
	11	.064	.060	.057	.053	.049	.046	.042	.038	.034	.030	.025	
FOUNDA-	12	.063	.060	.056	.053	.049	.045	.041	.037	.033	.029	.025	
	13	.063	.060	.056	.052	.049	.045	.041	.037	.033	.028		
TION	14	.063	.059	.056	.052	.048	.044	.040	.036	.032	.027		
	15	.063	.059	.055	.052	.048	.044	.040	.036	.031	.027		
	16	.063	.059	.055	.051	.047	.043	.039	.035	.031	.026		
	17	.062	.059	.055	.051	.047	.043	.039	.034	.030	.025		
AREA	18	.062	.058	.055	.051	.047	.042	.038	.034	.029			
	19	.062	.058	.054	.050	.046	.042	.037	.033	.028			
	20	.062	.058	.054	.050	.046	.041	.037	.032	.028			
	21	.061	.057	.053	.049	.045	.041	.036	.032	.027			
	22	.061	.057	.053	.049	.045	.040	.036	.031	.026			
	23	.061	.057	.053	.048	.044	.040	.035	.030	.025			
	24	.061	.057	.052	.048	.044	.039	.034	.029				
	25	.060	.056	.052	.048	.043	.038	.034	.029				

TABLE E-2  
FRAME WALL & BOX SILL U-VALUES FROM DIFFERENT  
BUILDING MATERIALS AND METHODS

Insulation Type	2 × 4 FRAMING 16" O.C. <sup>1</sup>	2 × 6 FRAMING 16" O.C.	2 × 6 FRAMING 24" O.C. <sup>2</sup>	Double 2 × 4 or 2 × 8 FRAMING 24" O.C.
R-11 Batt	0.091			
R-11 Batt, R1.22 Fiberboard	0.081			
R-11 Batt, R5.27 Polystyrene	0.060			
R-11 Batt, R10.54 Polystyrene	0.045			
R-11 Batt, R7.21 Isocyanurate	0.054			
R-11 Batt, R14.4 Isocyanurate	0.038			
R-13 Batt	0.083			
R-13 Batt, R1.22 Fiberboard	0.074			
R-13 Batt, R5.27 Polystyrene	0.056			
R-13 Batt, R10.54 Polystyrene	0.043			
R-13 Batt, R7.21 Isocyanurate	0.050			
R-13 Batt, R14.4 Isocyanurate	0.036			
R-19 Batt		0.080	0.058	0.056
R-19 Batt, R1.22 Fiberboard		0.055	0.053	0.052
R-19 Batt, R5.27 Polystyrene		0.044	0.043	0.042
R-19 Batt, R10.54 Polystyrene		0.036	0.035	0.034
R-19 Batt, R7.21 Isocyanurate		0.040	0.039	0.039
R-19 Batt, R14.4 Isocyanurate		0.031	0.030	0.030
Two R-11 Batts				0.053
Two R-11 Batts, R1.22 Fiberboard				0.049
Two R-11 Batts, R5.27 Polystyrene				0.040
Two R-11 Batts, R10.54 Polystyrene				0.033
Two R-11 Batts, R7.21 Isocyanurate				0.037
Two R-11 Batts, R14.4 Isocyanurate				0.029
Two R-13 Batts				0.048
Two R-13 Batts, R1.22 Fiberboard				0.045
Two R-13 Batts, R5.27 Polystyrene				0.037
Two R-13 Batts, R10.54 Polystyrene				0.030
Two R-13 Batts, R7.21 Isocyanurate				0.034
Two R-13 Batts, R14.4 Isocyanurate				0.027

<sup>1</sup>Assumes 20% framing, 80% cavity.

<sup>2</sup>Assumes 17% framing, 83% cavity.

#### MANUAL CALCULATION METHOD

To calculate the required wall U-value without using Tables E-1 and E-2, use the method outlined below:

Step 1: Calculate the above grade wall composition.

% Window area = 10.53%

% Door area = 2.12%

% Opaque foundation area = 6.10%

## Appendix

% Opaque wall & box sill area = 82.25%

Step 2: Use the following formula to calculate the maximum allowable U-value for the opaque wall and box sill.

$$U_o - \frac{(U_w \times \%w) - (U_d \times \%d) - (U_f \times \%f)}{\%wall} = U_{wall}$$

Where:

$U_o$	= Required overall above grade wall U-value, use 0.080 for an electrically heated home
$U_w$	= The U-value of the windows (= 1/R-value)
$\%w$	= The fraction of window area calculated in Step 1
$U_d$	= The U-value of the doors (= 1/R-value)
$\%d$	= The fraction of door area calculated in Step 1
$U_f$	= The U-value of the insulated foundation
$\%f$	= The fraction of exposed foundation calculated in Step 1
$\%wall$	= The fraction of opaque wall and box sill area as calculated in Step 1
$U_{wall}$	= The maximum U-value of the opaque wall and box sill to be calculated

In our example:

The window R-value = R-2.78                       $U = 1/2.78 = 0.341$

The door R-value = R-8.85                          $U = 1/8.85 = 0.113$

The foundation R-value = R-12.4                  $U = 1/12.4 = 0.080$

$$U_{wall} = \frac{0.080 - (0.341 \times 0.1053) - (0.113 \times 0.0212) - (0.080 \times 0.0610)}{0.8225} = 0.045$$

In this case, the maximum U-value of the opaque wall and box sill is 0.045 Btu/hr. sq. ft. °F. For compliance, the insulation which is installed in the wall and box sill must provide a U-value which is less than or equal to 0.045. Table E-3 shows the U-values obtainable from different insulation materials and framing types.

#### TABLE E-3 DIRECTIONS FOR USE

Table E-3 gives the amount of installed insulation which would be necessary to achieve a required U-value in the ceiling or attic.

Table E-3 was formulated with the following assumptions:

- The loose fill insulation, if used, is installed to provide the following R-values:
 

Cellulose	R = 3.7/in
Expanded perlite	R = 2.7/in
Mineral Fiber (rock, slag, or glass)	R = 3.3/in
Polystyrene beads	R = 2.9/in
Fiber glass, blown	R = 2.5/in

- The insulated area is 90% cavity and 10% 2 × 6 framing
- There are no skylights in the ceiling/attic assembly
- The R-value of the ceiling finish materials plus air films is R-1.2
- The attic hatch is insulated to the same level as the rest of the attic floor, if it is a part of the thermal envelope.

If these assumptions are not valid for your case, you may calculate the required U-value as shown after Table E-3.

TABLE E-3  
INSULATION LEVELS REQUIRED TO MEET  
CEILING U<sub>0</sub> VALUES

Dwelling Fuel Type	U <sub>0</sub>	Insulation Type	Amount Required In Cavity Depth (R-Value)
Electrically Heated	0.020	Fiber glass Batts	R-54
		Cellulose	14.1 in. (R-52)
		Expanded Pearlite	18.6 in. (R-50)
		Mineral Fiber	15.6 in. (R-51)
		Polystyrene Beads	17.5 in. (R-52)
		Blown Fiber glass	20.0 in. (R-50)

MANUAL CALCULATION METHOD

To calculate the required ceiling insulation level for ceiling/attic assemblies, use the following method.

Step 1: Calculate the required U-value for the attic floor, U<sub>F</sub>, with the following formula.

$$U_F = \frac{U_0 A_0 - U_s A_s - U_h A_h}{A_F}$$

Where:

- U<sub>F</sub> = The required U-value for the attic floor
- U<sub>0</sub> = The overall U-value set by the code, use 0.020 for an electrically heated dwelling
- A<sub>0</sub> = The overall attic/ceiling area including the attic floor, any skylights and the attic hatch or access panel
- U<sub>s</sub> = The U-value of the skylights including the frame
- A<sub>s</sub> = The area of skylights, including the frame (if there are no skylights, set equal to zero)
- U<sub>h</sub> = The U-value of the attic hatch or access panel
- A<sub>h</sub> = The area of the attic hatch or access panel (If the hatch is to be insulated to the same level as the attic floor, add the area to the floor area, A<sub>F</sub>, and set A<sub>h</sub> equal to zero. If the attic hatch or access panel is not a part of the thermal envelope, set A<sub>h</sub> equal to zero.)

## Appendix

$A_F$  = The area of the insulated attic floor, equal to the overall attic/ceiling area minus the attic hatch and skylight areas, if any.

**Example:** For the attic of an electrically heated dwelling with an overall attic area of 1500 sq. ft. The attic hatch is 14" x 24" and is to be insulated with two R-19 fiber glass batts, the rest of the attic is to be insulated with blown mineral fiber with an R-value of 3.3-R/inch. There are two skylights, each 6 square feet with R-values of 1.8.

The R-value of the attic hatch is the sum of the R-values of the batts plus R-2 for the finish materials and air films.

$$R = 19 + 19 + 2 = 40$$

$$\text{The U-value of the hatch is } U_h = 1/40 = 0.025$$

$$\text{The U-value of the skylights } U_s = 1/1.8 = 0.56$$

$$\text{The area of the hatch} = 2 \text{ ft} \times 1.17 \text{ ft} = 2.3 \text{ sq. ft.}$$

$$\text{The area of the skylights is 12 square feet}$$

$$\text{The area of the floor is } 1500 - 12 - 2.3 = 1486 \text{ sq. ft.}$$

$$U_F = \frac{(0.020)(1500) - (0.56)(12) - (0.025)(2.3)}{1486} = 0.0156$$

**Step #2:** To calculate the amount of insulation needed over the framing and cavity areas, d, of the attic floor use the following formula:

$$d = \frac{1}{U_F (R/in)} - \frac{(RW/in) h}{(\%C)(RW/in) + (\%W)(R/in)} - \frac{R_{fin} + h}{(R/in)}$$

Where:

- d = depth of insulation at cavity in inches
- $U_F$  = required U-value of floor calculated in Step #1
- R/in = R-value per inch of insulating material obtained from manufacturer or Table A-4
- h = height of framing, 5-1/2" for 2 x 6 framing or 7-1/4" for 2 x 8 framing, for example.
- %C = fraction of floor which is cavity (usually assume 0.9)
- %W = fraction of floor which is framing (usually assume 0.1)
- RW/in = R-value per inch of wood framing (usually assume 1.25 R/inch)
- $R_{fin}$  = R-value of interior ceiling finish materials, including air films (usually assume R-1.2)

$$d = \frac{1}{(0.0156)(3.3)} + 5.5 - \frac{(1.25)(5.5)}{(0.9)(1.25) + (0.1)(3.3)} - \frac{1.2}{3.3} = 19.59 \text{ inches}$$

The floor of the attic is to be covered with insulation so that the depth in the cavities is equal to 19.59 inches.

TABLE A-4  
COMMON CONSTRUCTION MATERIAL R-VALUES\*

Material	Description	Density (lb per cu ft)	Per inch thickness R-Value	For thick- ness listed R-Value
BUILDING BOARD	Asbestos-cement board . . . . .	120	0.25	—
	Asbestos-cement board . . . . .	120	—	0.03
Boards, panels, subflooring, sheathing,	Asbestos-cement board . . . . .	120	—	0.06
	woodbased panel products	Gypsum or plaster board . . . . .	50	—
	Gypsum or plaster board . . . . .	50	—	0.45
	Plywood . . . . .	34	1.25	—
	Plywood . . . . .	34	—	0.31
	Plywood . . . . .	34	—	0.47
	Plywood . . . . .	34	—	0.62
	Plywood or wood panels . . . . .	34	—	0.93
	Insulating board			
	Sheathing, reg. density . . . . .	18	—	1.32
	Sheathing, intermediate density . . . . .	18	—	2.06
	Sheathing, intermediate density . . . . .	22	—	1.22
	Nail-base sheathing . . . . .	25	—	1.14
	Shingle backer . . . . .	18	—	0.94
	Shingle backer . . . . .	18	—	0.78
	Sound deadening board . . . . .	15	—	1.35
	Tile and lay-in panels, plain or acoustic . . . . .	18	2.50	—
	Tile and lay-in panels, plain or acoustic . . . . .	18	—	1.25
	Tile and lay-in panels, plain or acoustic . . . . .	18	—	1.89
	Laminated paperboard . . . . .	30	2.00	—
	Homogeneous board from re pulped paper . . . . .	30	2.00	—
	Hardboard			
	Medium density siding . . . . .	40	—	0.67
	Other medium density . . . . .	50	1.37	—
	High density, underlay . . . . .	55	1.22	—
	High density std. tempered Particleboard	63	1.00	—
	Low density . . . . .	37	1.85	—
	Medium density . . . . .	50	1.06	—
	High density . . . . .	62.5	0.85	—
	Underlayment . . . . .	40	—	0.82
	Wood subfloor . . . . .	—	—	0.94
BUILDING PAPER	Vapor-permeable felt . . . . .	—	—	0.06
	Vapor-seal, 2 layers of mopped 15 lb. felt . . . . .	—	—	0.12
	Vapor-seal, plastic film . . . . .	—	—	Negl.
ROOF INSULATION	Preformed, for use above deck			
	Approximately . . . . .	—	—	1.39
	Approximately . . . . .	—	—	2.78
	Approximately . . . . .	—	—	4.17
	Approximately . . . . .	—	—	5.56
	Approximately . . . . .	—	—	6.87
	Approximately . . . . .	—	—	8.33
Cellular glass . . . . .	9	2.50	—	



## Appendix

Material	Description	Density (lb per cu ft)	Per inch thickness R-Value	For thick- ness listed R-Value
MASONRY MATERIALS	Cement mortar .....	116	0.20	—
	Gypsum-fiber concrete			
	87½% gypsum, 12% wood chips .....	51	0.60	—
	Lightweight aggregates	120	0.19	—
	including expanded shale,	100	0.28	—
	clay or slate, expanded	80	0.40	—
	slags; cinders; pumice;	60	0.59	—
	vermiculite; also cellular	40	0.86	—
	concretes	30	1.11	—
		20	1.43	—
	Perlite .....	40	1.08	—
		30	1.41	—
		20	2.00	—
	Sand and gravel or stone ag- gregate (oven dried) .....	140	0.11	—
	Sand and gravel or stone ag- gregate (not dried) .....	140	0.08	—
Stucco .....	116	0.20	—	
MASONRY UNITS	Brick, common .....	120	0.20	—
	Brick, face .....	130	0.11	—
	Clay tile, hollow:			
	1 cell deep .....	3 in.	—	0.80
	1 cell deep .....	4 in.	—	1.11
	2 cells deep .....	6 in.	—	1.52
	2 cells deep .....	8 in.	—	1.85
	2 cells deep .....	10 in.	—	2.22
	3 cells deep .....	12 in.	—	2.50
	Concrete blocks, 3 oval core:			
	Sand & gravel			
	aggregate .....	4 in.	—	0.71
		8 in.	—	1.11
		12 in.	—	1.28
	Cinder aggregate ..	3 in.	—	0.86
		4 in.	—	1.11
		8 in.	—	1.72
		12 in.	—	1.89
	Lightweight	3 in.	—	1.27
	aggregate(expanded	4 in.	—	1.50
	shale, clay, slate	8 in.	—	2.00
	or slag; pumice)	12 in.	—	2.27
	Concrete blocks, rectangular core			
	Sand & gravel			
	aggregate			
	2 core, 8" 36 lb	—	—	1.04
	Same with filled cores	—	—	1.93
Lightweight aggregate (ex- panded shale, clay, .....				
slate or slag, pumice): .....				
3 core, 6" 19 lb .....	—	—	1.65	
Same with filled cores .....	—	—	2.99	
2 core, 8" 24 lb .....	—	—	2.18	
Same with filled cores .....	—	—	5.03	
3 core, 12" 38 lb .....	—	—	2.48	
Same with filled cores .....	—	—	5.82	
Stone, lime or sand .....	—	0.08	—	
Gypsum partition tile: .....				
3 x 12 x 30 in. solid .....	—	—	1.26	
3 x 12 x 30 in. 4-cell .....	—	—	1.35	
4 x 12 x 30 in. 3-cell .....	—	—	1.67	
PLASTERING MATERIALS	Cement plaster, sand aggre- gate .....	116	0.20	—
	Sand aggregate ...	¾ in.	—	0.08
	Sand aggregate ...	¾ in.	—	0.15

Material	Description	Density (lb per cu ft)	Per inch thickness R-Value	For thick- ness listed R-Value
	Gypsum plaster:			
	Lightweight aggregate . . . . .	½ in. 45	—	0.32
	Lightweight aggregate . . . . .	¾ in. 45	—	0.39
	Lightweight aggregate on metal lath . . . . .	¾ in. —	—	0.47
	Perlite aggregate . . . . .	45	0.67	—
	Sand aggregate . . . . .	105	0.18	—
	Sand aggregate . . . . .	½ in. 105	—	0.09
	Sand aggregate . . . . .	¾ in. 105	—	0.11
	Sand aggregate on metal lath . . . . .	¾ in. —	—	0.1
	Vermiculite aggregate . . . . .	45	0.59	—
ROOFING	Asbestos-cement shingles 120	—	0.21	—
	Asphalt roll roofing . . . . .	70	—	0.15
	Asphalt shingles . . . . .	70	—	0.44
	Built-up roofing . . . . .	¾ in. 70	—	0.33
	Slate . . . . .	¾ in. —	—	0.05
	Wood shingles, plain plastic film faced . . . . .	—	0.94	—
SIDING MATERIALS (On flat surface)	Shingles:			
	Asbestos-cement . . . . .	120	—	0.21
	Wood, 16", 7½" exposure . . . . .	—	—	0.87
	Wood, double, 16", 12" exposure . . . . .	—	1.19	—
	Wood, plus insulating backer board . . . . .	5/16 in. —	—	1.40
	Siding:			
	Asbestos-cement, ¼" lapped . . . . .	—	—	0.21
	Asphalt roll siding . . . . .	—	—	0.15
	Asphalt insulating siding (½" bd.) . . . . .	—	—	1.46
	Wood drop 1 x 8" . . . . .	—	—	0.79
	Wood bevel, ½" x 8" lapped . . . . .	—	—	0.81
	Wood bevel, ¾" x 10" lapped . . . . .	—	—	1.05
	Wood plywood ¾" lapped . . . . .	—	—	0.59
	Aluminum or steel, over sheathing, hollow-backed insulating-board backed nominal ¾" . . . . .	—	—	0.61
	Insulating-board backed nominal ¾" . . . . .	—	—	1.82
	Insulating-board backed nominal ¾" foil backed . . . . .	—	—	2.96
	Architectural glass . . . . .	—	—	0.10
FINISH FLOORING MATERIALS	Carpet and fibrous pad . . . . .	—	—	2.08
	Carpet and rubber pad . . . . .	—	—	1.23
	Cork tile . . . . .	¾ in. —	—	0.28
	Terrazzo . . . . .	1 in. —	—	0.08
	Tile-asphalt, linoleum, vinyl, rubber . . . . .	—	—	0.05
	Wood, hardwood finish . . . . .	¾ in. —	—	0.08
INSULATING MATERIALS	Blanket and batt			
	Mineral fiber, fibrous form processed from rock, slag or glass			
	Approx. 2 to 2½" . . . . . Note 1	—	—	7
	Approx. 3 to 3½" . . . . . Note 1	—	—	11
	Approx. 5½" to 6½" . . . . . Note 1	—	—	19

Material	Description	Density	Per inch	For thick-	
		(lb per cu ft)	thickness R-Value	ness listed R-Value	
Board and Slabs	Cellular glass .....	9	2.50	—	
	Glass fiber, organic bonded ...	4-9	4.00	—	
	Expanded rubber (rigid) .....	4.5	4.55	—	
	Expanded polystyrene ex- truded, plain .....	1.8	4.00	—	
	Expanded polystyrene ex- truded (R-12 exp.) .....	2.2	5.00	—	
	Expanded polystyrene ex- truded (R-12 exp.) (Thickness 1" and greater) .....	3.5	5.26	—	
	Expanded polystyrene, molded beads .....	1.0	3.57	—	
	Expanded polyurethane (R-11 exp.) .....	1.5	6.25	—	
	Mineral fiber with resin binder .....	15	3.45	—	
	Mineral fiberboard wet felted Core or roof insulation .....	16-17	2.94	—	
	Acoustical tile .....	18	2.86	—	
	Acoustical tile .....	21	2.70	—	
	Mineral fiberboard wet molded Acoustical tile .....	23	2.38	—	
	Wood or cane fiberboard Acoustical tile ... ½ in.	—	—	1.25	
	Acoustical tile ... ¾ in.	—	—	1.89	
	Interior finish (plank, tile) ...	15	2.86	—	
	Insulating roof deck Approximately .. 1½ in.	—	—	4.17	
	Approximately .... 2 in.	—	—	5.56	
	Approximately .... 3 in.	—	—	8.33	
	Wood shredded (cemented in preformed slabs) .....	22	1.67	—	
	Foil faced, glass fiber — reinforced cellular polyisocyanurate .....	2	7.04	—	
	Nominal 0.5 in .....	2	—	3.6	
	Nominal 1.0 in .....	2	—	7.2	
	Nominal 2.0 in .....	2	—	14.4	
	Loose Fill	Cellulose insulation (milled paper or wood pulp) .....	2.5-3	3.70	—
		Sawdust or shavings .....	0.8-1.5	2.22	—
		Wood fiber, softwoods .....	2.0-3.5	3.33	—
Perlite, expanded .....		5.0-8.0	2.70	—	
Mineral fiber (rock, slag or glass): Approximately 3" .....		Note 1 8-15	—	9	
Approximately 4½" .....		Note 1 8-15	—	13	
Approximately 6½" .....		Note 1 8-15	—	19	
Approximately 7½" .....		Note 1 8-15	—	24	
Silica aerogel .....		7.6	5.88	—	
Vermiculite (expanded) .....		7.0-8.2	2.13	—	
.....		4.0-6.0	2.27	—	
WOODS	Maples, oak and similar hard- woods .....	45	0.91	—	
	Fir, pine, and similar softwoods .....	32	1.25	—	
	Fir, pine, and similar softwoods .....	32	—	0.94	
	..... ¾ in.	—	—	1.89	
	..... 1½ in.	32	—	—	

Material	Description	Density (lb per cu ft)	Per inch thickness R-Value	For thick- ness listed R-Value
	..... 2½ in.	32	—	3.12
	..... 3¼ in.	32	—	4.35

Note 1: R-value varies with fiber diameter. Insulation is produced by different densities; therefore, there is a wide variation in thickness for the same R-value between various manufacturers. (See Batt and Loose Fill Insulation.)

\*Reprinted with permission from ASHRAE Handbook of Fundamentals 1972.

**TABLE A-5**  
**COEFFICIENTS OF TRANSMISSION (U) OF WINDOWS, SKYLIGHTS, AND LIGHT TRANSMITTING PARTITIONS \***  
 (These values are for heat transfer from air to air.)  
 Btu per (hr) (sq ft) (F Deg)

**PART A**  
**VERTICAL PANELS (EXTERIOR WINDOWS, SLIDING PATIO DOORS**  
**AND PARTITIONS) — FLAT GLASS, GLASS BLOCK AND**  
**PLASTIC SHEET**

Description	Exterior <sup>1</sup>		Interior
	Winter	Summer	
Flat Glass			
single glass	1.13	1.06	0.78
insulating glass—double <sup>2</sup>			
3/16 in. air space	0.69	0.64	0.51
1/4 in. air space	0.65	0.61	0.49
1/2 in. air space	0.58	0.56	0.46
1/2 in. air space, low emissivity coating <sup>3</sup>			
emissivity = 0.20	0.38	0.36	0.32
emissivity = 0.40	0.45	0.44	0.38
emissivity = 0.60	0.52	0.50	0.42
insulating glass—triple <sup>2</sup>			
1/4 in. air spaces	0.47	0.45	0.38
1/2 in. air spaces	0.36	0.35	0.30
storm windows			
1 in.-4 in. air space	0.56	0.54	0.44
Glass Block <sup>4</sup>			
6 x 6 x 4 in. thick	0.60	0.57	0.46
8 x 8 x 4 in. thick	0.56	0.54	0.44
—with cavity divider	0.48	0.46	0.38
12 x 12 x 4 in. thick	0.52	0.50	0.41
—with cavity divider	0.44	0.42	0.36
12 x 12 x 2 in. thick	0.60	0.57	0.46
Single Plastic Sheet	1.09	1.00	0.70

<sup>1</sup>See Part C for adjustment for various window and sliding patio door types.

<sup>2</sup>Double and triple refer to the number of lights of glass.

<sup>3</sup>Coating on either glass surface facing air space; all other glass surfaces uncoated.

<sup>4</sup>Dimensions are nominal.

**PART B**  
**HORIZONTAL PANELS (SKYLIGHTS)**  
**FLAT GLASS, GLASS BLOCK AND PLASTIC BUBBLES**

Description	Exterior <sup>1</sup>		Interior <sup>5</sup>
	Winter <sup>5</sup>	Summer <sup>d</sup>	
Flat Glass			
single glass	1.22	0.83	0.96
insulating glass—double <sup>2</sup>			
3/16 in. air space	0.75	0.49	0.62
1/4 in. air space	0.70	0.46	0.59
1/2 in. air space	0.66	0.44	0.56
1/2 in. air space, low emissivity coating <sup>3</sup>			
emissivity = 0.20	0.46	0.31	0.39
emissivity = 0.40	0.53	0.36	0.45
emissivity = 0.60	0.60	0.40	0.50
Glass Block <sup>4</sup>			
11 x 11 x 3 in. thick with cavity divider	0.53	0.35	0.44
12 x 12 x 4 in. thick with cavity divider	0.51	0.34	0.42
Plastic Bubbles <sup>7</sup>			
single walled	1.15	0.80	—
double walled	0.70	0.46	—

<sup>5</sup>For heat flow up.

<sup>6</sup>For heat flow down.

<sup>7</sup>Based on area of opening, not total surface area.

(See following page for Part C of this table.)

**PART C**  
**ADJUSTMENT FACTORS FOR VARIOUS WINDOW AND**  
**SLIDING PATIO DOOR TYPES**  
 (Multiply U values in Parts A and B by these factors)

Description	Single Glass	Double or Triple Glass	Storm Windows
<b>Windows</b>			
All Glass <sup>8</sup>	1.00	1.00	1.00
Wood Sash—80% Glass	0.90	0.95	0.90
Wood Sash—60% Glass	0.80	0.85	0.80
Metal Sash—80% Glass	1.00	1.20	1.20 <sup>9</sup>
<b>Sliding Patio Doors</b>			
Wood Frame	0.95	1.00	—
Metal Frame	1.00	1.10	—

<sup>8</sup>Refers to windows with negligible opaque area.

<sup>9</sup>Value becomes 1.00 when storm sash is separated from prime window by a thermal break.

**TABLE A-6**  
**COEFFICIENTS OF TRANSMISSION (U) FOR SLAB DOORS\***  
 Btu per (hr) (sq ft) (F Deg)

Thickness <sup>1</sup>	Winter			
	Solid Wood, No Storm Door	With Storm Door		Summer, No Storm Door
		Wood	Metal	
1 in.	0.64	0.30	0.39	0.61
1½ in.	0.55	0.28	0.34	0.53
1½ in.	0.49	0.27	0.33	0.47
2 in.	0.43	0.24	0.29	0.42
<b>Steel Door</b>				
1½ in.				
A <sup>3</sup>	0.59	—	—	0.58
B <sup>4</sup>	0.19	—	—	0.18
C <sup>5</sup>	0.47	—	—	0.46

<sup>1</sup>Nominal thickness.

<sup>2</sup>Values for wood storm doors are for approximately 50% glass; for metal storm doors values apply for any percent of glass.

<sup>3</sup>A = Mineral fiber core (2 lb/cu ft).

<sup>4</sup>B = Solid urethane foam core with thermal break.

<sup>5</sup>C = Solid polystyrene core with thermal break.

Note: Hollow core doors 1½ in. thick - R = 2.17; U = 0.46  
 1½ in. thick - R = 2.22; U = 0.45

\*Reprinted with permission from ASHRAE Handbook of Fundamentals.

## APPENDIX C

INSULATION, EQUIPMENT AND  
CONDENSATION CONTROL

This appendix is a guide for the proper installation of insulation. The preceding appendices indicated the required amounts and types of insulation necessary to provide the various thermal resistance values for the building envelope. In order to attain the resistance values specified, it is important that the insulation be properly installed. This appendix includes types of materials currently available and common application practices.

Condensation control should be provided in the form of vapor barriers and thermal breaks. Vapor barriers should be installed on the warm side (area heated in winter) of all walls, ceilings, and insulated floors. All metal window, skylight, and door frames should contain a thermal break.

Insulation is manufactured in many forms and types. The most commonly used materials in residential construction are batts and blankets, rigid insulation, reflective insulation, loose fill, and sprayed insulation. The following is a list of types of materials and the federal specifications governing their characteristics.

Cork board .....	FS HH-I-561
Cellular glass .....	FS HH-I-551
Duct insulation .....	FS HH-I-558b
Expanded polystyrene insulation board ...	FS HH-I-524
Fiberboard.....	FS LLL-I-535 or ASTM C-208 Class C
Insulation board (urethane)* .....	FS HH-I-530
Insulation, thermal (perlite).....	FS HH-I-574
Mineral fiber, pneumatic or poured .....	FS HH-I-1030A
Mineral fiber, insulation blanket .....	FS HH-I-521E
Perlite .....	FS HH-I-526a
Perimeter insulation.....	FS HH-I-524a
.....	Type II
.....	FS HH-I-558b Form A, Class 1 or 2
Reflective, thermal .....	FS HH-I-1552
Structural fiberboard insulation roof deck	AIMA IB Spec. No. 1
Cellulose; vegetable or wood fiber .....	FS HH-I-515b-25
Vermiculite .....	FS HH-I-585
Vermiculite, water repellent loose fill.....	FHA UM-30
Mineral fiber, roof insulation .....	HH-I-526c

## BATTS AND BLANKETS

These materials are usually identified on the package and on the vapor barrier facing with their "R" values. Under the federal specifications, there are 3 standard products identified as R-7, R-11, and R-19. These values are based on the insulation value of the mass. Some manufacturers offer other products such as R-8, R-13 and R-22. The specific thickness of insulation required for a specific "R" value may vary from one manufacturer to another due to differences in base materials and manufacturing processes.

### General Guidelines

1. Install insulation so the vapor barrier faces the interior of the dwelling.
2. Vapor barriers should not be left exposed.
3. Insulate all voids of the building envelope including small spaces, gaps, around receptacles, pipes, etc.
4. Place insulation on the cold side of pipes and ducts (see Fig. 4). Insulation is not required for supply and return air ducts in heated basements and cellars.

### Ceilings

There is a variety of methods for installing blanket insulation in ceilings.

1. Fastening from below (Fig. 1b).
2. Installing unfaced (without a vapor barrier), friction-fit blankets (Fig. 2).
3. Laying the insulation in from above when the ceiling finish material is in place (Fig. 1a).

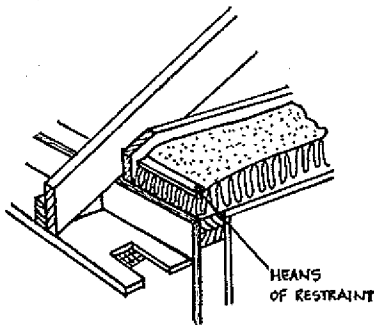

Fig. 1a

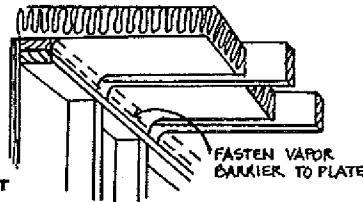

Fig. 1b

Fasten flanges to the inside of ceiling joists as shown in Fig. 1b. Extend the insulation entirely across the top plate, keeping the blanket as close to the plate as possible. Fasten vapor barrier to plate. When eave vents are used, the insulation should not block air movement from eave to space above insulation (Fig. 1a).



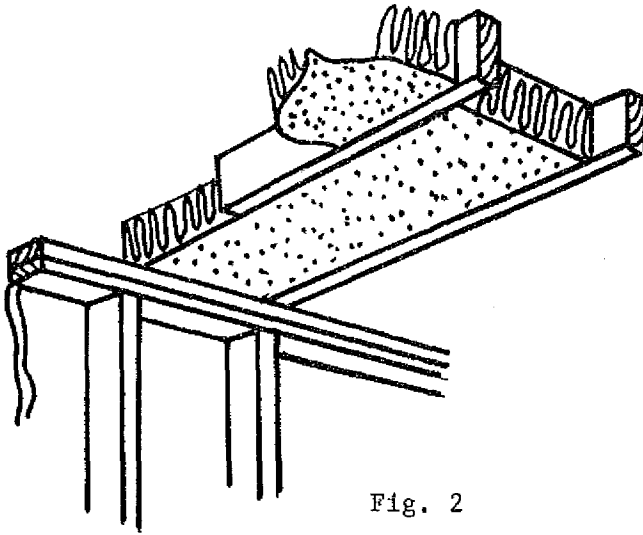

Fig. 2

Insert friction-fit blankets between ceiling joists (Fig. 2). Allow insulation to overlap the top plate of the exterior wall, but not enough to block eave ventilation. The insulation should be in contact with the top of the plate to avoid heat loss and air infiltration beneath the insulation. The required vapor barrier is not shown.

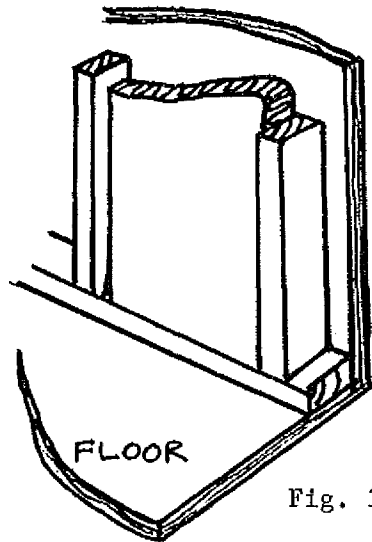

Fig. 3

Insert blankets into stud spaces. Working from the top down, space fasteners per manufacturers recommendations, fitting flanges tightly against face of stud (Fig. 3). Cut blankets slightly over length and fasten the vapor barrier to the top and bottom plates.

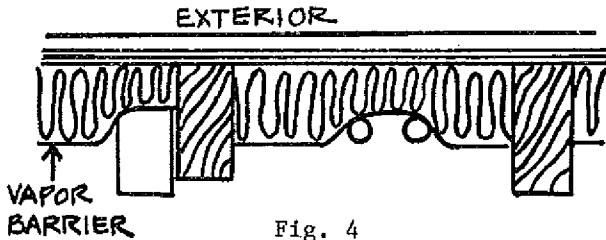

Fig. 4

Insert insulation behind (cold side in winter) pipes, ducts, and electrical boxes (Fig. 4).

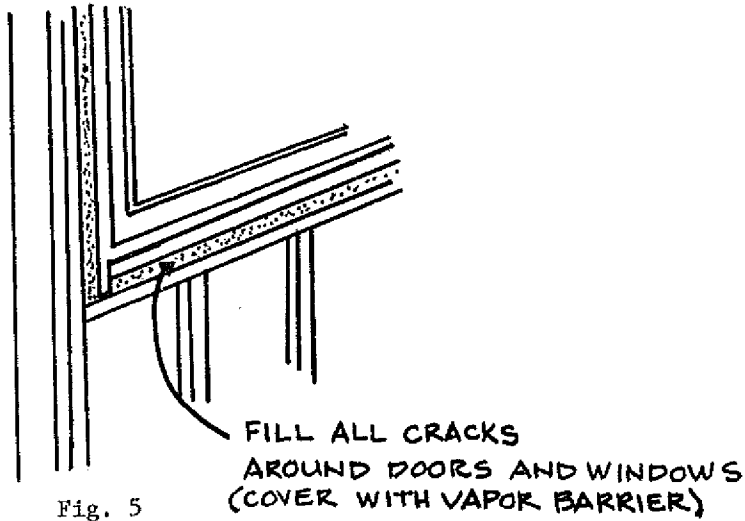

Fig. 5

Fill small spaces between rough framing and door and window heads, jambs and sills with pieces of insulation (Fig. 5).

## Appendix

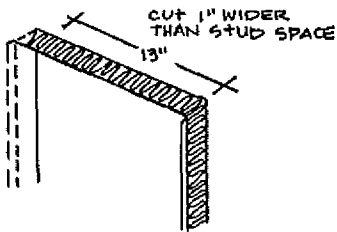

Fig. 6a

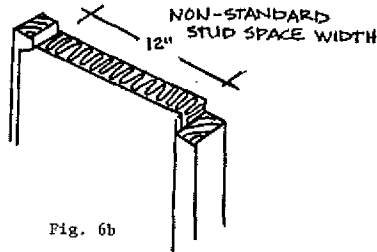

Fig. 6b

Insulate nonstandard-width stud or joist spaces by cutting the insulation and vapor barrier an inch or so wider than the space to be filled (Fig. 6a). Pull the vapor barrier on the cut side to the other stud, compressing the insulation behind it, and fasten through vapor barrier to stud face (Fig. 6b). Unfaced blankets are cut slightly oversize and fitted into place.

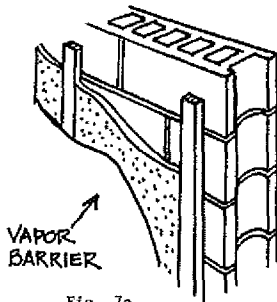

Fig. 7a

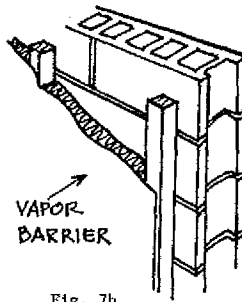

Fig. 7b

Masonry walls may be insulated by inserting insulation between furring strips spaced at 16 or 24 inches o.c. (Fig. 7a and 7b). It is recommended to apply the vapor barrier to the inside surface.

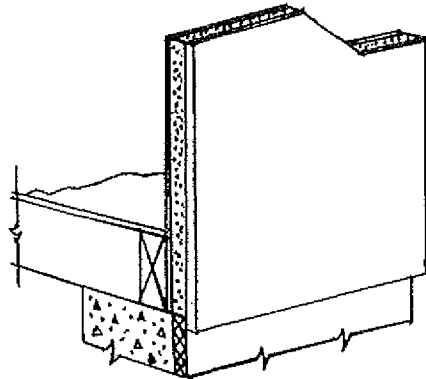

Fig. 8

Rigid insulation in stress skin panels (Fig. 8) may also be used to insulate walls, ceilings and roofs. .

#### *Floor and Crawl Spaces*

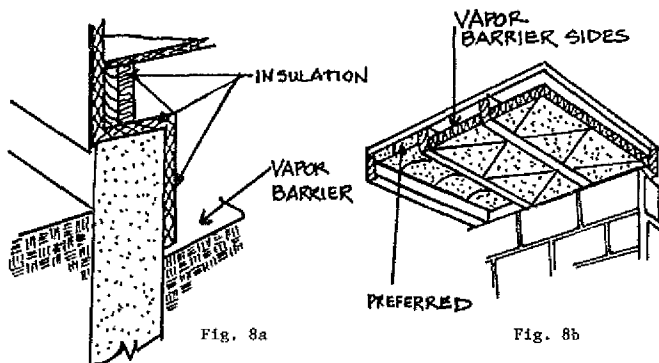

Fig. 8a

Fig. 8b

Floors over crawl spaces (Fig. 8a) should be insulated either by insulating the foundation walls or by placing insulation on or between the joists. Insulation should be securely fastened. In all cases, the vapor barrier side of the insulation should face the floor above; that is, be adjacent to the warm side in winter. A vapor barrier should be used to cover the ground.

*Dropped Soffits*

Insulation of dropped soffits over kitchen cabinets, bathtubs, showers, or similar areas, need special attention when they are exposed to the attic. If the dropped soffit is framed before ceiling finish material is applied, a "board" (plywood, hardboard, gypsumboard, etc.) should be installed over the cavity to support insulation.

In multiple dwellings with back-to-back kitchens or baths, it is necessary to extend ceiling finish material over dropped soffits to the party wall to avoid loss of acoustical control and to provide adequate fire stops.

*Rigid Insulation*

Rigid insulation is available in various sizes and thicknesses made of polystyrene, polyurethane, cork, cellular glass, mineral fiber (glass or rock wool), perlite, wood fiberboard, etc. They are used as insulation for masonry construction, as perimeter insulations around concrete slabs, as exterior sheathing under the weather barrier, as rigid insulations on top of roof decks, and other applications.

*Installation Procedures*

*Masonry walls:* Rigid insulations are applied to either face of a masonry wall (Fig. 9a and 9c) or are used as a cavity insulation between two wythes of masonry (Fig. 9b). When applied to the face of masonry walls, they are generally installed with adhesive and/or mechanical fasteners. The manufacturer's recommendation should be followed.

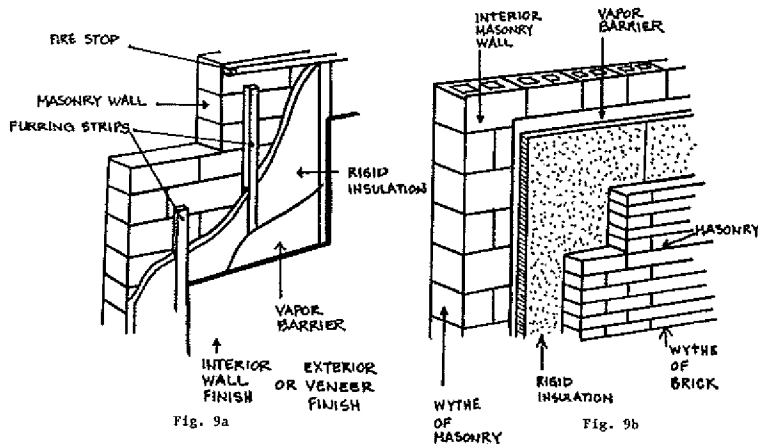

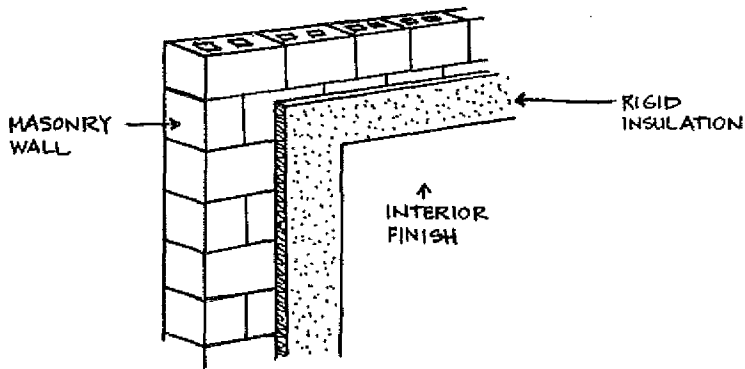

Fig. 9c

*Frame Construction:* When rigid insulation is used with frame construction (Fig. 10), it is usually applied as sheathing to the outside of the framing, and mechanically attached with nails to wood studs or to metal studs with screws or clips or other approved methods.

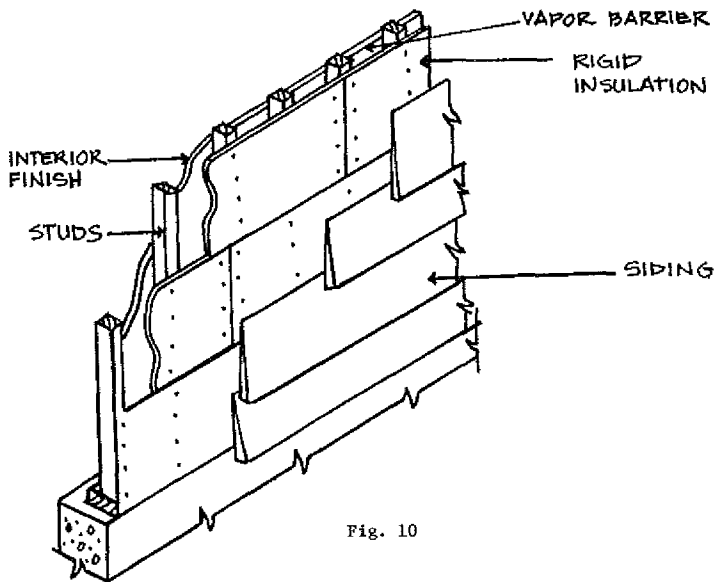

Fig. 10

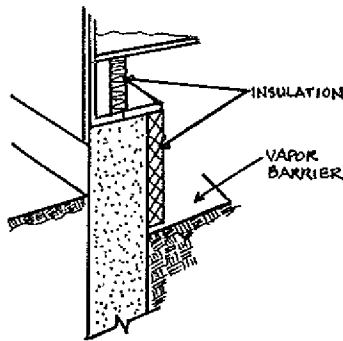

Fig. 11a

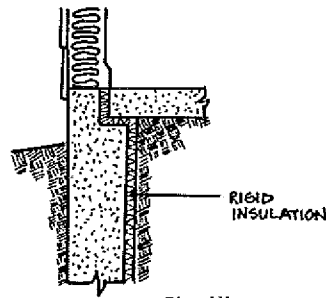

Fig. 11b

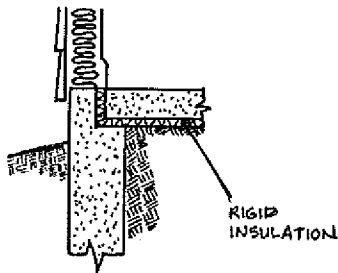

Fig. 11c

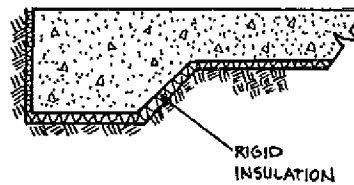

Fig. 11d

**Roof Insulation:** Roof insulation boards are usually installed with an approved adhesive, hot asphalt, or may be nailed to the roof sheathing. The manufacturer's instructions should be followed.

**Slab-on-Grade:** Rigid insulation is frequently used as insulation around the perimeter of concrete slabs-on-grade (Fig. 11b, c, d) and also may be used on the inside of foundation walls adjacent to heated crawl spaces, basements or cellars (Fig. 11a). Installation is usually accomplished with adhesive and/or mechanical fasteners. Perimeter insulation should be installed against the foundation wall or extended into the interior of the building to a distance equal to the design frost line (Fig. 11b, c and d). Where the slab bears on the foundation ledge, the insulation should be a load-bearing type.

### INSULATED CONCRETE BLOCK

Concrete block manufacturers are currently producing several types of multi-celled block with improved insulating values. The thermal resistance of the block will vary depending upon the types of insulation used and the configuration of the cells. An example of a typical multi-celled block is shown below.

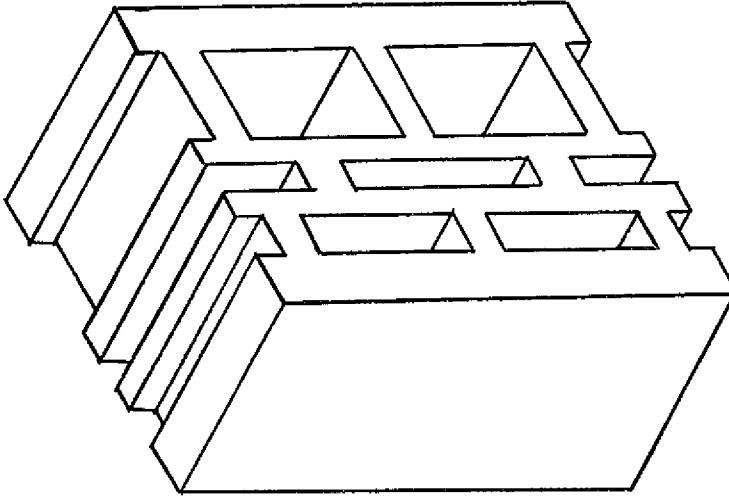

### LOOSE FILL INSULATION

Materials of this type are those made from mineral fibers (rock or glass), cellulose materials (wood fibers or shredded paper), or other manufactured products that can easily be poured.

### BLOWN ATTIC INSULATION

There are several factors pertaining to blown attic insulation that can cause differences in its installed thermal resistance value ( $R$ ). For a given manufacturer's insulation, the installed thermal resistance ( $R$ ) value depends on thickness and weight of insulating material applied per square foot. Federal specification HH-I-1030A for insulation requires that each bag of insulation be labeled to show the minimum thickness, the maximum net coverage, and the minimum weight of (that particular) insulation material required per square foot to produce resistance values of  $R-30$ ,  $22$ ,  $19$ , and  $11$ . A bag label example for blown insulation is shown in Fig. 12.

The number of bags of blown insulation required to provide a given  $R$ -value to insulate an attic of a given size may be calculated from data provided by the manufacturer. If only the thickness of blown attic insulation is specified, and the density or number of bags is not, the desired or



assumed thermal resistance (R) value may not be achieved. The important characteristic is weight per square foot. Thickness is the minimum thickness, not the average thickness experienced in the field.

Adequate baffling of the vent opening or insulation blocking should be provided so as to deflect the incoming air above the surface of the installed blown or poured insulation. Baffles should be made of durable material securely fastened. Baffles should be in place at the time of framing inspection.

Three blown insulations that provide R-19 are:

Material	Minimum Thickness	Maximum Net Coverage/Bag	Bags/1000 Sq. Ft.
Cellulose	5½"	59 sq. ft. (40 lb. bag)	17
Glass fiber	8¾"	51 sq. ft. (24 lb. bag)	20
Rock wool	6½"	26 sq. ft. (27 lb. bag)	38

*Bag Label Example:* The manufacturer recommends these maximum coverages at these minimum thicknesses to provide the levels of installed insulation resistance (R) values shown:

(Based on 25-pound nominal weight bag)

R-Value	Minimum Thickness	Minimum Weight per Sq. Ft.	Bags per 1000 Sq. Ft.	Maximum Net Coverage per Bag
To obtain an insulation resistance R of:	Installed insulation should not be less than:	The weight per sq. ft. of installed insulation should be not less than:	Number of bags per 1000 sq. ft. of net area should not be less than:	Contents of this bag should not cover more than:
R-30	13¾ in. thick	0.768 lbs. per sq. ft.	30	33 sq. ft.
R-22	10 in. thick	0.558 lbs. per sq. ft.	22	45 sq. ft.
R-19	8¾ in. thick	0.489 lbs. per sq. ft.	20	51 sq. ft.
R-11	5 in. thick	0.279 lbs. per sq. ft.	11	90 sq. ft.

Weight contents: not less than 24 lbs.

R-values are determined in accordance with ASTM C-687 and C-236

Fig. 12

### REFLECTIVE INSULATION

Reflective insulation is composed of aluminum foil in one or more layers either plain or laminated to one or both sides of kraft paper for structural strength. The insulation value for reflective air spaces, which this type of insulation provides, varies widely depending on the direction of heat flow. They are much more efficient when the heat flow is *down*. Reflective insulations which comply with the requirements when used in a floor, may not be satisfactory in ceilings or walls, where the heat flow is upward and horizontal, respectively. Reflective insulations a reflective in controlling radiant heat energy when installed so that they face an air space. Insulation should be installed in such a manner that it is continuous, without holes or tears.

### SPRAYED INSULATION

There are several types of insulation which are sprayed against the surface of the building materials or in cavities. Some of these are cellulose

with binder, mineral wool with binder, and cellular foams. They may be sprayed directly on concrete, masonry, wood, plastic, or metal panels or may be sprayed between the framing members. Manufacturer's recommended instructions should be followed. To determine that the proper thickness is installed, either refer to the plans and specifications, or request a certification from the supplier that the insulation installed provides the required "R" value.

TYPICAL INSULATION THICKNESSES AND VALUES

Insulation	Approximate R-Value	Thickness
Fiber glass	11	3½"
Fiber glass	13	3¾"
Fiber glass	19	6"
Fiber glass	30	8"
Fiber glass	38	12"
Extruded Polystyrene Foam	5.4	1"
Extruded Polystyrene Foam	10.8	2"

VAPOR RETARDERS

Vapor retarders are used in conjunction with insulation to decrease the change of moisture condensation inside the building insulation. Vapor retarders are placed on the side of the wall, ceiling or floor that is warm in winter. For equal vapor pressures, moisture vapor penetration through holes or tears in the insulation vapor retarder is proportional to the size of the opening. Holes or tears should be repaired. A snug fit of blanket flanges against the framing is necessary to prevent moisture from bypassing the vapor retarder.

EQUIPMENT

The installation of the heating system can contribute to inefficiencies. A furnace which is oversized by a factor of 2 will require 8 to 10% more fuel than a furnace of correct size. An installation that has uninsulated ducts passing through an unheated crawl or attic space will lose about 1.5 Btu per hour per square foot of duct per degree of temperature differential between duct air and outside air. This can amount to 40% of a furnace output under mild conditions. Undersized ducting will reduce the amount of circulating air and will affect the capacity of the furnace, but will normally have little effect upon its efficiency. Atmospheric combustion equipment that draws its combustion and stack-dilution air from the heated space will require more fuel to heat the required makeup air than sealed combustion equipment. Stack heat recovery devices can recover from about 4% at 450° F to 8% at 800° F.

The appliance manufacturer should be consulted when retrofitting the appliance with combustion air to assure that the appliance warranty is not affected.

*Effect of Sizing Limitation on Equipment*

Using the example on system design illustrated in Appendix A, an analysis was made to see what impact or problem the proposal for limiting the size of equipment to 15% above the design losses would have.

Example:

Total construction loss 27,760 Btu/hour

One air change per hour:

Inside volume = 12,188 cu. ft.

$Q = (12,188) (90) (.018) = 19,744$  Btu/hour

Total infiltration loss  $\frac{19,744 \text{ Btu/hour}}{47,504 \text{ Btu/hour}}$

Maximum furnace size:

$47,504 \text{ Btu/hour} + 47,504 (.15) \text{ Btu/hour} = 54,630 \text{ Btu/hour}$

#### COMBUSTION AIR FOR FIREPLACES

It is recommended that combustion air from the exterior be provided for all fireplaces. Masonry fireplaces can be made more energy efficient with combustion air terminating in the fireplace. The opening of the fireplace should be equipped with a door and the combustion air duct with a damper and a louver to minimize air leakage during periods of nonuse.

#### CONDENSATION CONTROL

##### *Air Infiltration*

The department will accept infiltration losses determined by the air crack method or an overall value of  $\frac{1}{2}$  air change per hour.

The department will accept the use of engineered top-side moisture vent systems.

##### *Relative Humidity*

*Winter:* During the winter it is desirable to have humidity in the air in order to prevent the nostrils from becoming dry, furniture from cracking, etc. However, from an energy standpoint, it is desirable to keep the relative humidity low; the trade-off is at about 30%.

*Summer:* During the summer it is desirable to reduce the level of relative humidity in the building in relationship to the outside relative humidity. The relative humidity should be kept as high as possible in order to conserve energy, but low enough for comfort. The relative humidity should be kept above 55%, but less than 60%.

**APPENDIX D**  
**ILLUSTRATIONS OF EXTERIOR OPENINGS IN**  
**THE THERMAL ENVELOPE**

The following illustrations show some exterior openings in the thermal envelope which may be sealed to control infiltration. A detailed list of sealing requirements for electrically heated homes is given in s. ILHR 22.13 (3).

ILHR 22.13 Infiltration Control for Electrically Heated Homes

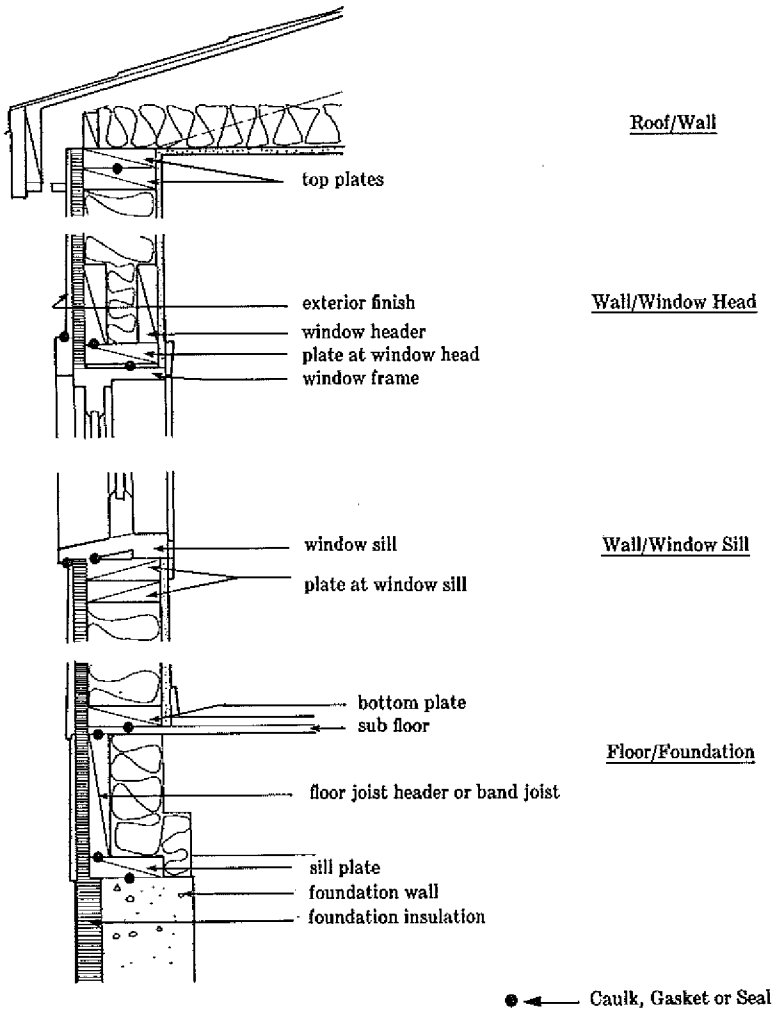

ILHR 22.13 Infiltration Control for Electrically Heated Homes  
(continued)

