

Chapter Ind 23

HEATING, VENTILATING AND AIR CONDITIONING
STANDARDS**Part I Scope**

Ind 23.01 Scope (p. 71)

PART II Design

Ind 23.02 Design (p. 71)

Part III Heating Equipment

Ind 23.03 Selection of equipment (p. 72)

Ind 23.04 Types of equipment (p. 72)

Ind 23.05 Safety controls (p. 81)

Ind 23.06 Combustion air (p. 81)

Part IV Delivery Systems

Ind 23.07 Air distribution systems (p. 81)

Ind 23.08 Ductwork (p. 82)

Ind 23.09 Dampers, registers and grilles
(p. 84)

Ind 23.10 Piping (p. 84)

Part V Chimneys and Vents

Ind 23.11 General requirements (p. 84)

Ind 23.12 Masonry chimneys (p. 85)

Ind 23.13 Factory-built chimneys or vents
(p. 86)

Ind 23.14 Gas vents (p. 86)

Ind 23.15 Chimney connectors, smoke
pipes and stovepipes (p. 86)**Part VI Fuel Supply Systems**

Ind 23.16 Fuel storage (p. 88)

Part VII Equipment Location and**Operation**

Ind 23.17 Equipment location (p. 89)

Ind 23.18 Operation (p. 90)

PART I—SCOPE

Ind 23.01 Scope. The provisions of this chapter shall apply to the design, installation and construction of all heating, ventilating and air conditioning systems in dwellings covered by this code.

History: Cr. Register, November, 1979, No. 287, eff. 6-1-80.

PART II—DESIGN

Ind 23.02 Design. Every dwelling shall be equipped with a heating system designed in accordance with this section. Heating equipment requirements may be waived for recreational dwellings used only during the non-heating season. Where a cooling system is provided, the cooling requirements of this section shall be met.

(1) **HEATING AND COOLING SYSTEM DESIGN.** Indoor and outdoor design temperatures shall be selected from section Ind 22.04. The heating and cooling systems shall be designed to maintain the indoor design temperature at outdoor design conditions. When requested, room-by-room heat loss and heat gain calculations shall be furnished.

(2) **DISTRIBUTION SYSTEMS.** Distribution systems shall be sized and located to satisfy the heating and cooling loads of each conditioned space. When requested, a layout of the distribution system shall be furnished to show that the system meets the requirements of this code.

(3) **VENTILATION.** Habitable rooms without openable windows shall be provided with a mechanical ventilation system producing one air change per hour. All required exhaust vents shall terminate outside the structure. Ductless recirculating fans may be used if approved by the department.

Note: The department will accept designs which meet the Air Conditioning Contractors of America manual; the Mechanical Contractors Association manual; and the Sheet Metal and Air Conditioning Contractors National Association standards for heating and air conditioning systems for one- and 2-family dwellings.

Register, November, 1979, No. 287
Heating, Ventilating and Air Conditioning Standards

Ind 23

(4) **CONTROLS.** The temperature rise through the equipment shall not exceed 100° F unless listed. Controls shall be provided to maintain the inside temperature. Where forced, warm-air systems are used, controls shall be installed to control air movement.

History: Cr. Register, November, 1979, No. 287, eff. 6-1-80.

PART III—HEATING EQUIPMENT

Ind 23.03 Selection of equipment. All heating and central cooling equipment shall be selected on the basis of air-handling capacity, pumping capacity, and thermal capacity to handle the calculated design heating or cooling load.

History: Cr. Register, November, 1979, No. 287, eff. 6-1-80.

Ind 23.04 Types of equipment. Heating and cooling appliances shall be listed by a recognized testing agency. The clearances in tables 23.04-A and 23.04-B shall apply unless otherwise shown on listed appliances.

TABLE 23.04-A
STANDARD INSTALLATION CLEARANCES (INCHES) FOR HEAT-PRODUCING APPLIANCES

Residential Type Appliances for Installation in Rooms Which are Large (See Note 2)		Appliance ¹				
		Above Top of Casing or Appliance	From Top and Sides of Warm- Air Bonnet or Plenum	From Front See Note 3	From Back	From Sides
Boilers and Water Heaters	Automatic Oil					
Steam Boilers - 15 psi	or	6	—	24	6	6
Water Boilers - 250° F	Comb. Gas-Oil	6	—	18	6	6
Water Heaters - 200° F	Automatic Gas	6	—	48	6	6
All Water Walls or Jacketed	Solid	6	—	18	6	6
	Electric	6	—	18	6	6
Furnaces - Central	Automatic Oil					
Gravity, Upflow, Downflow, Horizontal and Duct, Warm-Air - 250° F	or	6'	6'	24	6	6
	Comb. Gas-Oil	6'	6'	18	6	6
	Automatic Gas	18'	18'	48	18	18
	Solid	6'	6'	18	6	6
	Electric	6'	6'	18	6	6
Furnaces - Floor	Automatic Oil					
For Mounting in Combustible Floors	or	36	—	12	12	12
	Comb. Gas-Oil	36	—	12	12	12
	Automatic Gas	36	—	12	12	12
	Electric	36	—	12	12	12
Heat Exchanger						
Steam - 15 psi Max.		1	1	1	1	1
Hot Water - 250° F Max.	—	1	1	1	1	1
Room Heaters						
Circulating Type	Oil or Solid	36	—	24	12	12
Vented or Unvented	Gas	36	—	24	12	12
	Oil or Solid	36	—	36	36	36
Radiant or Other Type	Gas	36	—	36	18	18
Vented or Unvented	Gas with dbl metal or ceramic back	36	—	36	12	18
Radiators						
Steam or Hot Water	Gas	36	—	6	6	6

Heating, Ventilating and Air Conditioning Standards
 Register, November, 1979, No. 287

TABLE 23.04-A (CONTINUED)

Residential Type Appliances for Installation in Rooms Which are Large (See Note 2)		Appliance ¹					
		Above Top of Casing or Appliance	From Top and Sides of Warm- Air Bonnet or Plenum	From Front See Note 3	From Back	From Sides	
		See Note 6			Firing Side	Opp. Side	
Ranges - Cooking Stoves Vented or Unvented	Oil	30	—	—	9	24	18
	Gas	30	—	—	6	6	6
	Solid - Clay lined firepot	30	—	—	24	24	18
	Solid - Un- lined firepot	30	—	—	36	36	18
	Electric	30	—	—	6	6	6
Clothes Dryers	Gas	6	—	24	6	6	
Listed Types	Electric	6	—	24	0	0	
Incinerators		See Note 7					
Residential Types	—	36	—	48	36	36	

¹Standard clearances may be reduced by affording protection to combustible material in accordance with Table 23.04-B.

²Rooms which are large in comparison to the size of the appliance are those having a volume equal to at least 12 times the total volume of a furnace and at least 16 times the total volume of a boiler. If the actual ceiling height of a room is greater than 8 feet, the volume of a room should be figured on the basis of a ceiling height of 8 feet.

³The minimum dimension should be that necessary for servicing the appliance including access for cleaning and normal care, tube removal, etc.

⁴For a listed oil, combination gas-oil, gas, or electric furnace this dimension may be 2 inches if the furnace limit control cannot be set higher than 250° F or this dimension may be one inch if the limit control cannot be set higher than 200° F.

⁵The dimension may be 6 inches for an automatically stoker-fired forced warm-air furnace equipped with 250° F limit control and with barometric draft control operated by draft intensity and permanently set to limit draft to a maximum intensity of 0.13 in. water gauge.

⁶To combustible material or metal cabinets. If the underside of such combustible material or metal cabinet is protected with asbestos millboard at least ¼-inch thick covered with sheet metal of not less than No. 28 gauge, the distance may be not less than 24 inches.

⁷Clearance above charging door should be not less than 48 inches.

TABLE 23.04-B
CLEARANCES, INCHES, WITH SPECIFIED FORMS OF PROTECTION^{1,2}

Type of Protection Applied to the combustible material unless otherwise specified and covering all surfaces within the distance specified as the required clearance with no protection. Thicknesses are minimum.	Where required clearance with no protection is												
	36 inches			18 inches			12 inches		9 inches		6 inches		
	Above	Sides & Rear	Chimney or Vent Connector	Above	Sides & Rear	Chimney or Vent Connector	Above	Sides & Rear	Chimney or Vent Connector	Above	Sides & Rear	Chimney or Vent Connector	
(a) 1/4-in. asbestos millboard spaced out 1 in.	30	18	30	15	9	12	9	6	6	3	2	3	
(b) 0.013 in. (28 gage) sheet metal on 1/4-in. asbestos millboard.	24	18	24	12	9	12	9	6	4	3	2	2	
(c) 0.013 in. (28 gage) sheet metal spaced out 1 in.	18	12	18	9	6	9	6	4	4	2	2	2	
(d) 0.013 in. (28 gage) sheet metal on 1/4-in. asbestos millboard spaced out 1 in.	18	12	18	9	6	9	6	4	4	2	2	2	
(e) 1-1/2 in. asbestos cement covering on heating appliance.	18	12	36	9	6	18	6	4	9	2	1	6	
(f) 1/4-in. asbestos millboard on 1 in. mineral fiber bats reinforced with wire mesh or equivalent.	18	12	18	6	6	6	4	4	4	2	2	2	
(g) 0.027 in. (22 gage) sheet metal on 1 in. mineral fiber bats reinforced with wire or equivalent.	18	12	12	4	3	3	2	2	2	2	2	2	
(h) 1/4-in. asbestos millboard.	36	36	36	18	18	18	12	12	9	4	4	4	
(i) 1/4-in. cellular asbestos.	36	36	36	18	18	18	12	12	9	3	3	3	

¹Except for the protection described in (e), all clearances should be measured from the outer surface of the appliance to the combustible material disregarding any intervening protection applied to the combustible material.

²Asbestos millboard referred to above is a different material from asbestos cement board. It is not intended that asbestos cement board be used in complying with these requirements when asbestos millboard is specified.

Register, November, 1979, No. 287
Heating, Ventilating and Air Conditioning Standards

(1) **FURNACES.** The input and output capacity of furnaces shall be listed on the nameplate. All nameplates shall show evidence that the equipment has been listed by a recognized testing laboratory.

(a) *Fuel supply.* Furnaces shall be fired with the fuel for which they have been approved, except as provided in (1) (d) of this section. Fuels shall be supplied to the furnace in the volume and at the pressure required on the label.

(b) *Unvented fuel-fired furnaces and space heaters.* Unvented fuel-fired furnaces and space heaters shall be prohibited in dwellings.

(c) *Vented wall furnaces.* Vented wall furnaces shall not be equipped with duct extensions beyond the vertical and horizontal limits of the enclosure unless listed. Vented wall furnaces shall be located to prevent the reflection of air circulation by doors, projections, or other openings. Vented wall furnaces shall be provided with combustion air.

(d) *Conversion burners.* Conversion burners shall be listed by a recognized testing laboratory. The existing equipment shall be reconditioned and defective parts replaced before a conversion burner is installed. Conversion burners shall be installed in accordance with the installation instructions.

(e) *Location.* No furnace shall be placed in a bedroom, bathroom, closet or garage unless listed for such installation.

(2) **HEAT PUMP APPLIANCES.** (a) *Size.* Heat pump appliances shall be sized to provide control of the wet and dry bulb temperatures during cooling and maximum performance during heating. The heating balance point shall be considered to determine the outdoor temperature at which the heat pump must operate 100% of the time to offset the dwelling heat loss.

(b) *Auxiliary heaters.* Provisions for auxiliary heat to supplement the heat pump at outdoor temperatures below the balance point shall be provided. Auxiliary heaters shall be sized so that the heat pump auxiliary will offset the dwelling heat loss down to the heating design temperature.

(3) **BOILERS.** Boilers shall comply with Wis. Adm. Code chapters Ind 41-42, Boiler and Pressure Vessel Code, sections Ind 41.10 and Ind 41.50 through 41.53.

Note: The department will accept equipment listed by the American Society of Mechanical Engineers, Underwriters' Laboratories, and the American Gas Association.

(4) **SOLID-FUEL-BURNING APPLIANCES.** Solid-fuel-burning appliances shall comply with the following requirements:

(a) *Floor protection.* Stoves may be installed on combustible floors provided the floor is protected with a material such as 24-gauge or thicker sheet metal, 1/4-inch or thicker asbestos millboard covered with 24-gauge sheet metal, 4-inch hollow bricks, or 4 inches of stone or concrete, or equivalent. Such protection shall extend beneath the stove, at least 12 inches beyond all sides and at least 18 inches beyond sides having a door or other similar opening. Stoves shall have a clearance of at least 4 inches to the floor.

(b) *Chimneys.* Wood-burning appliances shall be connected to a masonry chimney with a flue liner or an all-fuel, residential type factory-built chimney. Wood-burning equipment shall not be connected to a flue serving a fireplace or other equipment. The chimney shall be designed to create a natural draft to carry away the products of combustion or provision shall be made for mechanically maintaining constant updraft during equipment operation. A cleanout opening shall be provided.

(c) *Chimney connector or stovepipe.* The chimney connector or stovepipe shall comply with Table 23.15-A.

(d) *Damper.* A manual cast iron damper to control the draft shall be provided in the chimney connector next to the appliance.

(e) *Supplemental units.* Supplemental wood-burning units connected to a furnace shall be connected to the warm air side of the furnace in accordance with illustrations 23.01-A, 23.01-B or 23.01-C.

1. *Return air duct.* The area of the return air duct shall be at least equal to the area of the warm air supply duct. The return air duct shall be of the same material as specified for supply air ducts.

2. *Blower.* The blower on the furnace shall maintain the manufacturer's specifications for CFM and static pressure when the supplemental unit is in operation.

3. *Outside air intake.* The outside air intake shall be connected to the cold air return plenum of the furnace. A volume damper shall be placed in the duct for the fresh air intake.

4. *Thermostat.* The thermostat control on the supplemental heating unit shall activate the blower motor at a temperature between 100° and 120° F.

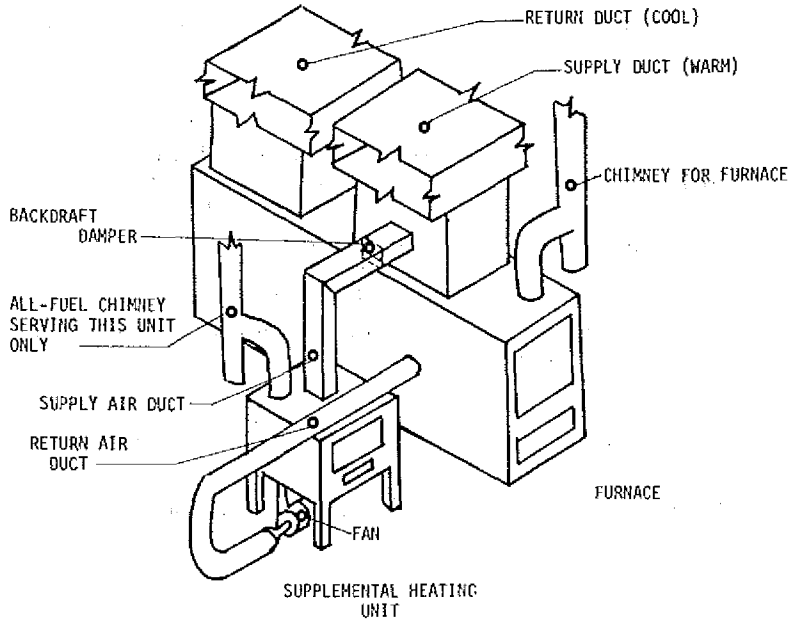

FIGURE 23.01-A

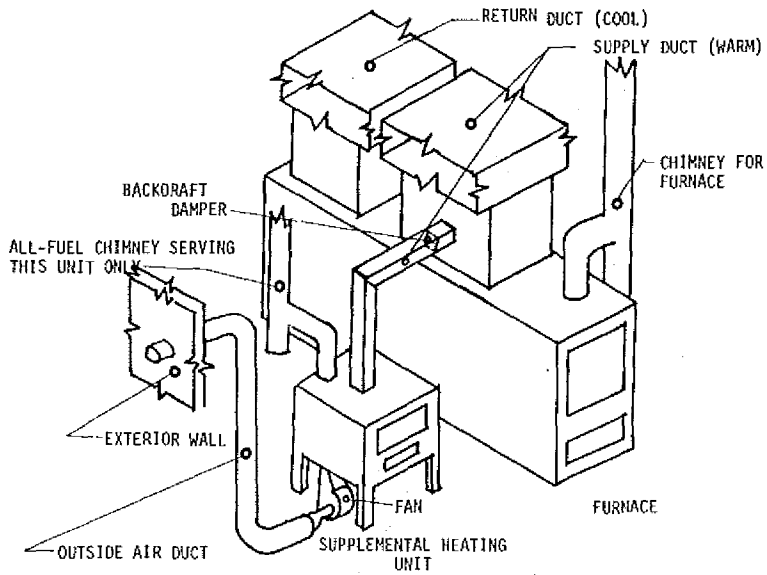

FIGURE 23.01-B

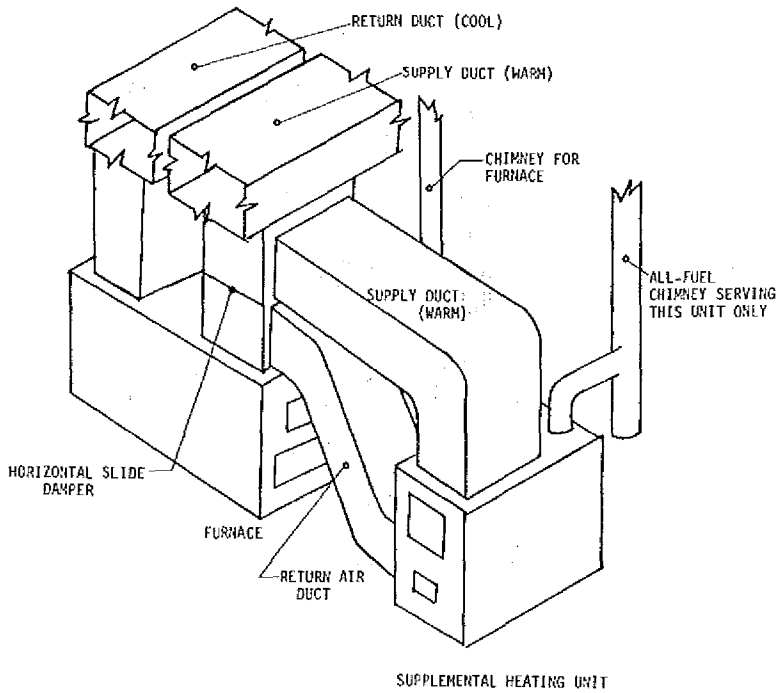

FIGURE 23.01-C

History: Cr. Register, November, 1979, No. 287, eff. 6-1-80.

Register, November, 1979, No. 287
Heating, Ventilating and Air Conditioning Standards

Ind 23.05 Safety controls. High limit, maximum outlet air temperature and similar safety controls shall be provided on heating equipment.

History: Cr. Register, November, 1979, No. 287, eff. 6-1-80.

Ind 23.06 Combustion air. All fuel-burning heating equipment, except sealed combustion appliances, cooking appliances, refrigerators and clothes dryers, shall be provided with a supply of air for fuel combustion.

(1) **EQUIPMENT LOCATED IN UNCONFINED SPACES.** (a) *Infiltration.* Combustion air may be provided by means of infiltration where the volume of the room (measured in cubic feet) in which the burner is located is greater than 1/20 of the maximum input BTU rating of the burner (s).

(b) *Openings.* Where exterior openings are used to provide combustion air from the outside to appliances located in unconfined spaces, the opening shall be designed to provide one square inch of area for each 5,000 BTU per hour of input rating.

(2) **EQUIPMENT LOCATED IN CONFINED SPACES.** Combustion air provided to equipment located in confined spaces shall be installed in accordance with the following:

(a) *Air from inside the dwelling.* Two openings shall be provided to the equipment enclosure. One opening shall be located within 12 inches from the floor and one opening shall be located within 24 inches from the top of the room. Each opening shall provide a minimum area of one square inch per 1,000 BTU per hour input.

(b) *Air from outside the dwelling.* Two openings shall be provided to the equipment enclosure. One opening shall be located within 12 inches from the floor and one opening shall be located within 24 inches from the top of the room. Each opening shall provide a minimum area of one square inch per 4,000 BTU per hour input.

History: Cr. Register, November, 1979, No. 287, eff. 6-1-80.

PART IV—DELIVERY SYSTEMS

Ind 23.07 Air distribution systems. (1) **SIZING.** All air distribution systems shall be sized using the velocities and static pressure losses listed in Table 23.07.

TABLE 23.07
 DUCT VELOCITIES

Designation	Maximum Static Pressure Loss (in WG/100 ft)	Minimum Velocity (feet/minute)	Maximum Velocity (feet/minute)
Main trunk duct	.10	700-900	800-1200
Branch duct	.10	600	700-1000
Branch riser	.10	500	650-800
Outdoor intake	.10	500	800
Grilles or openings	.10	400	600
Return air door undercuts	.10	200	300
Return air door or wall louvers	.10	200	300

WG = Water gauge per 100 feet.

Register, November, 1979, No. 287
 Heating, Ventilating and Air Conditioning Standards

(2) **SYSTEM SIZING.** The distribution system, including the evaporator coil, air filters (installed external to the heating unit), ducts, fittings, grilles and registers, shall be sized so that the total external static pressure shall not exceed the static pressure capacity of the fan at the system rated air flow.

(3) **CHANGES IN DUCT SIZE.** Where duct sizes are changed, the slope angle of the transition duct shall not exceed 45°.

History: Cr. Register, November, 1979, No. 287 eff. 6-1-80.

Ind 23.08 Ductwork. (1) *Duct use.* Ducts designed for the transmission of air shall be used for no other purpose.

(2) **INTERIOR DUCTS.** All interior ducts shall be constructed in accordance with the following:

(a) *Supply and return air ducts.* All supply and return air ducts shall be constructed of sheet metal or lined with sheet metal or other noncombustible materials.

1. **Exception.** Nonmetallic ducts or flexible ducts may be used except in connection with kitchen exhaust ducts or where the duct air temperature exceeds 250° F. Nonmetallic or flexible ducts shall not be connected to a furnace unless a connecting duct of sheet metal, having a length of at least 6 feet, is used to separate nonmetallic ducts from the appliance.

2. **Exception.** Unlined wood joists and stud spaces may be used as return air ducts. Wood joists and stud spaces used as return air ducts shall be cut off from all remaining unused portions by tight-fitting stops of sheet metal or of wood at least 2 inches nominal thickness. Bridging shall be removed from the joist space.

(3) **EXTERIOR DUCTS.** Ducts located outside the dwelling (in garages, attics and similar spaces) shall be constructed of galvanized steel or corrosion-resistive metal.

(4) **UNDERGROUND DUCTS.** Ducts, plenums and fittings constructed of asbestos cement, metal encased in concrete or ceramic, or other approved materials, may be installed in the ground. Supply air ducts installed parallel and adjacent to an outside wall shall be insulated with a moistureproof material having a resistance value of at least R-5 to a depth of at least 48 inches.

(5) **METAL STANDARDS.** All sheet metal ducts and fittings shall be constructed in compliance with standards approved by the department.

Note: The department will accept ducts designed in accordance with the ASHRAE Handbook of Fundamentals, published by the American Society of Heating, Refrigerating and Air-Conditioning Engineers, or as illustrated in the low velocity or high velocity duct construction standards published by the Sheet Metal and Air Conditioning Contractors National Association, Inc.

(6) **THICKNESS.** Ducts shall conform to the minimum thicknesses listed in Table 23.08-A.

(7) **DUCT SUPPORT.** Ductwork shall be fastened in place and braced to prevent lateral displacement in accordance with Table 23.08-B.

TABLE 23.08-A

DUCT CONSTRUCTION MINIMUM SHEET METAL GAUGES

		Minimum thickness galvanized sheet gauge	Minimum thickness aluminum B & S gauge
Metal gauges (duct not enclosed in partitions)			
Round ducts			
Diameter, inches			
Less than 12		30	26
12-14		28	26
15-18		26	24
Over 18		24	22
Rectangular Ducts			
Width, inches			
Less than 14		28	24
14-24		26	22
25-30		24	22
Over 30		22	20
Metal gauges (ducts enclosed in partition)			
Width, inches			
14 or less		30	26
Over 14		28	24

TABLE 23.08-B

DUCT SUPPORT MATERIAL

Duct Type	Maximum Size of Diameter (inches)	Duct Position	Hanger or Strap Size and Spacing
Circular	10	Vertical	No. 18 gage galvanized steel x 2" @ 12' o.c.
		Horizontal	No. 30 gage galvanized steel x 1" or No. 18 steel wire @ 10' o.c.
	20	Vertical	No. 16 gage galvanized steel x 2" @ 12' o.c.
		Horizontal	No. 28 gage galvanized steel x 1" or No. 18 steel wire @ 10' o.c.
Rectangular ¹	24	Vertical	1" x 1/8" steel galvanized strap @ 12' o.c.
		Horizontal	No. 18 gage galvanized steel x 1" @ 10' o.c.
		Vertical	1" x 1-1/8" galvanized steel angle @ 12' o.c.
		Horizontal	1" x 1/8" galvanized steel strap @ 10' o.c.

¹Rectangular metal duct supports should consist of one hanger attached to one-inch wide circular bands of the duct extending around and supporting ducts exceeding 10 inches in diameter.

Note: This table does not prohibit nailing for duct support.

(8) JOINTS AND SEAMS. All joints and seams shall be securely fastened or locked. Round pipe slip joints shall be lapped at least one inch.

Register, November, 1979, No. 287
Heating, Ventilating and Air Conditioning Standards

Ind 23

(9) **VIBRATION CONTROL.** When used, vibration isolation connectors shall be installed at the joint between the duct and fan or heating equipment. Vibration isolation connectors shall not be used where the air temperature is in excess of 250° F.

History: Cr. Register, November, 1979, No. 287, eff. 6-1-80.

Ind 23.09 Dampers, registers and grilles. (1) **VOLUME AND BACK-DRAFT DAMPERS.** Volume duct dampers shall be provided to permit balancing of the system. No supply ducts shall terminate in a garage without a backdraft damper.

(2) **AIR REGISTERS AND GRILLES.** (a) *Supply air registers.* All supply air outlets shall be provided with registers or devices which will provide a uniform distribution of air.

(b) *Return air grilles.* Return air grilles shall not be located in bathrooms, kitchens, garages, utility spaces or a confined space in which a draft diverter or draft regulator is located. All other habitable spaces shall have permanent openings to a return air grille equal in area to the supply outlet serving those areas. At least one return air opening shall be provided for each floor.

Ind 23.10 Piping. (1) **PIPE SIZES AND ARRANGEMENT.** All steam and hot water supply and return piping, air-line piping and auxiliary equipment shall be of appropriate sizes, elevations and arrangements to accomplish the calculated results without stress or other detriment.

Note: The sizes of pipe to be used for mains and risers may be selected from the ASHRAE Guide and Data Book, published by the American Society of Heating, Refrigerating and Air Conditioning Engineers; or the manuals published by the Institute of Boiler and Radiator Manufacturers or the Mechanical Contractors Association of America.

(2) **EXPANSION AND CONTRACTION.** The piping for the heating system shall be equipped with anchors, expansion swings or joints, supports and similar devices to relieve stress and strain caused by temperature change of the pipe material.

(3) **PIPE INSULATION.** Unguarded steam, hot water supply and return piping shall be covered with insulating material where the pipes pass through occupied areas and the surface temperature exceeds 180° F.

(4) **STEAM AND HOT WATER PIPES.** No pipe carrying hot water or steam at a surface temperature exceeding 250° F shall be placed within one inch of any combustible material, pass through a combustible floor, ceiling or partition unless the pipe is protected by a metal sleeve one inch larger in diameter than the pipe or with approved pipe covering.

(5) **BALANCING.** Balancing cocks shall be provided in each circuit of a hot water distribution system.

History: Cr. Register, November, 1979, No. 287, eff. 6-1-80.

PART V—CHIMNEYS AND VENTS

Ind 23.11 General requirements. All heating appliances using solid, liquid or gas fuels shall be vented to the outside by an all-fuel factory-built or masonry chimney designed to remove the products of combustion. Gas-fired water heaters may be connected to an approved type "B"

Register, November, 1979, No. 287
Heating, Ventilating and Air Conditioning Standards

vent. Vented wall furnaces may be connected to an approved type "BW" vent. Listed appliances with direct vent systems may also be used.

(1) **TERMINATION.** All chimneys or vents depending on a principle of gravity for the removal of the products of combustion shall extend at least 3 feet above the highest point where the chimneys and vents pass through the roof of the building, and at least 2 feet higher than any ridge, peak, wall, or roof within 10 feet horizontally of the chimney or vent.

(2) **CHIMNEY OR VENT INLETS.** Two appliances using the same type of fuel may be vented into the same flue provided the separate inlets are offset at least 12 inches vertically; or the separate inlets occur at right angles to each other; or the appliances are connected to a single inlet through a common manifold. Chimneys serving fireplaces or other solid-fuel-burning appliances shall not be used to vent any other equipment or appliance.

History: Cr. Register, November, 1979, No. 287, eff. 6-1-80.

Ind 23.12 Masonry chimneys. Masonry chimneys shall conform to the provisions of this section.

(1) **MATERIALS.** No masonry chimney shall rest upon wood. Combustible headers, beams, rafters, joists and studs shall be located at least 2 inches from the outside face of a chimney and at least 6 inches from the inside surface of the flue lining. The foundation shall be designed and built in conformity with the requirements for foundations. Masonry chimney walls shall be at least 4 inches nominal in thickness.

(2) **FLUE SIZE.** Chimney flues for appliances shall be at least equal in area to that of the area of the connector from the appliance.

(3) **MULTIPLE FLUE SEPARATION.** When more than one flue is contained in the same chimney, a masonry separation of at least 4 inches nominal in thickness shall be provided between the individual flues. The flue joints shall be staggered by at least 7 inches.

(4) **CORBELING.** Unless designed through structural analysis, masonry chimneys shall not be corbeled from a wall more than 6 inches nor shall a masonry chimney be corbeled from a wall less than 12 inches in thickness unless it projects equally on each side of the wall. The corbeling shall not exceed one-inch projection for each brick course.

(5) **INLETS.** Thimbles shall be at least No. 24 manufacturer's standard gauge (.024 inch) or 3/8-inch thick refractory material. Each chimney shall have an inlet installed at the time of construction.

(6) **CLEAN-OUT OPENING.** Every masonry chimney shall be provided with a clean-out opening at the base. Such openings shall be equipped with metal doors and frames arranged to remain closed when not in use.

(7) **FLUE LINERS.** (a) Masonry chimneys shall be lined with fireclay flue lining at least 3/8-inch thick, or with material that will resist corrosion, softening or cracking from flue gases at temperatures up to 1800° F. Flue liners shall commence at the chimney footing.

(b) Where chimneys are built for solid-fuel burning, flue liners shall be laid in a full mortar bed of refractory mortar.

Ind 23

(8) **CHIMNEY CAPS.** Precast or cast-in-place concrete caps shall have a minimum thickness of 2 inches and a minimum of one inch overhang. A minimum of a ¼-inch soft joint shall be used between flues and caps and shall be caulked or sealed.

History: Cr. Register, November, 1979, No. 287, eff. 6-1-80.

Ind 23.13 Factory-built chimneys or vents. Factory-built chimneys or vents shall be of an approved type.

Note: The department recognizes as approved, factory-built chimneys or vents designated as "residential type and building heating appliance," "building heating appliance," "B," "BW," and "L" types listed by Underwriters' Laboratories, Inc.

(1) **RESIDENTIAL TYPE AND BUILDING HEATING APPLIANCE.** An approved "residential type and building heating appliance" chimney or a "building heating appliance only" chimney may be used with solid, liquid or gas-fired heating appliances where the flue gas temperature does not exceed 1000° F continuously, and does not exceed 1400° F for infrequent brief periods of forced firing.

(2) **TYPE "B".** An approved type "B" gas vent may be used with a vented, recessed wall heater.

(3) **TYPE "BW".** An approved type "BW" gas vent may be used with a vented, recessed wall heater.

History: Cr. Register, November, 1979, No. 287, eff. 6-1-80.

Ind 23.14 Gas vents. All gas-fired equipment shall be provided with vent pipes conforming to the requirements for smoke pipes or for gas vents as specified in section Ind 23.15 (2) (g).

History: Cr. Register, November, 1979, No. 287, eff. 6-1-80.

Ind 23.15 Chimney connectors, smoke pipes and stovepipes. (1) **DEFINITION.** Chimney connectors, smoke pipes or stovepipes are passages for conducting the products of combustion from a fuel-fired appliance to the chimney.

(2) **CONSTRUCTION AND INSTALLATION.** The construction and installation of chimney connectors shall conform with the following requirements:

(a) **Concealed space.** No chimney connector shall pass through any outside window, door or combustible outside wall, nor be concealed in any closet, attic or similar space.

(b) **Combustible partitions.** Connectors for appliances shall not pass through walls or partitions constructed of combustible material unless they are guarded at the point of passage by:

1. Metal ventilated thimbles not less than 12 inches larger in diameter than the connector;

2. Metal or burned fireclay thimbles built in brickwork or other approved fireproofing materials extending not less than 8 inches beyond all sides of the thimble.

(c) **Distance from materials.** No part of any chimney connector shall be placed nearer to any combustible partition or wall than the diameter of the pipe, nor nearer to any non-fire-resistive ceiling than 1-½ times

Register, November, 1979, No. 287
Heating, Ventilating and Air Conditioning Standards

the diameter. The above distances may be reduced by one-half if the wall or ceiling is covered with not less than ¼-inch asbestos board covered with sheet metal or with equivalent protection.

Note: See Table 23.04-B for reduced clearances.

(d) *Multiple appliance venting.* Two or more listed appliances using the same type of fuel may be connected to a common gravity-type flue provided the appliances are equipped with listed primary safety controls and listed shutoff devices and comply with the following requirements.

1. The appliances shall be located in the same story, except for engineered venting systems.

2. The appliances shall be joined at a manifold or Y-type fitting as close to the chimney as possible, unless the connector from each appliance enters a separate chimney inlet and the inlets are offset in accordance with the requirements of section Ind 23.11 (2).

3. The chimney connector and chimney flue shall be sized to accommodate the total volume of flue gases. For gas-burning appliances, the venting area shall be at least equal to the size of the largest vent connectors plus at least 50% of the area of the other vent connectors.

(e) *Pitch and length.* Chimney or vent connectors shall have no more than two 45° offsets with the vertical. The horizontal length shall not exceed 75% of the total vertical height of the total venting system measured from the appliance outlet. Chimney or vent connectors shall be pitched at least ¼-inch per foot from the appliance outlet collar vent to the chimney inlet.

(f) *Dampers.* The use of manually operated dampers shall be prohibited in chimney or vent connectors of all appliances except wood-burning appliances. When used, listed automatically operated dampers interlocked with the heating appliance shall be installed in accordance with the approved listing.

(g) *Materials and thickness.* Chimney or vent connectors serving liquid and solid fuel appliances shall conform to the type of material and thickness indicated in tables 23.15-A or 23.15-B.

(h) *Clearance.* Single wall metal connectors shall be installed with clearance to combustibles as indicated in Table 23.15-C. These clearances may be reduced if the combustible material is protected in accordance with the requirements of Table 23.04-B.

TABLE 23.15-A

MINIMUM CHIMNEY CONNECTOR GAGES FOR OIL, WOOD AND COAL

Diameter of Connector	Galvanized Steel Gage Number	
	Min. thickness (inch)	Gage
Less than 6 inches	.019	26
6 inches to less than 10 inches	.024	24
10 inches to 13 inches	.030	22
14 inches to 16 inches	.036	20
Greater than 16 inches	.058	16

TABLE 23.15-B
MINIMUM VENT CONNECTOR GAGES FOR GAS

Diameter of Connector	Galvanized Steel Gage Number	
	Min. thickness (inch)	Gage
1 inch through 4 inches	.016	28
5 inches or over	.026	24

TABLE 23.15-C
CHIMNEY CONNECTOR AND VENT CONNECTOR CLEARANCES
FROM COMBUSTIBLE MATERIALS (See Note 4)

Description of Appliance	Minimum Clearance Inches (See Note 1)
Single-Wall Metal Pipe Connectors	
Gas Appliances Without Draft Hoods	18
Electric, Gas, and Oil Incinerators	18
Oil and Solid-Fuel Appliances	18
Unlisted Gas Appliances With Draft Hoods	9
Boilers and Furnaces Equipped With Listed Gas Burners and With Draft Hoods	9
Oil Appliances Listed as Suitable for Use With Type L Venting Systems, but only when connected to chimneys	9
Listed Gas Appliances With Draft Hoods. See Note 3.	6
Type L Vent Piping Connectors	
Gas Appliances Without Draft Hoods	9
Electric, Gas, and Oil Incinerators	9
Oil and Solid-Fuel Appliances	9
Unlisted Gas Appliances With Draft Hoods	6
Boilers and Furnaces Equipped With Listed Gas Burners and With Draft Hoods	6
Oil Appliances Listed as Suitable for Use with Type L Vents	(See Note 2)
Listed Gas Appliances With Draft Hoods	(See Note 3)
Type B Gas Vent Piping Connectors	
Listed Gas Appliances With Draft Hoods	(See Note 3)

¹These clearances apply except if the listing of an appliance specifies different clearance, in which case the listed clearance takes precedence.

²If listed type L venting system piping is used, the clearance may be in accordance with the venting system listing.

³If listed type B or type L venting system piping is used, the clearance may be in accordance with the venting system listing.

⁴The clearances from connectors to combustible materials may be reduced if the combustible material is protected in accordance with Table 23.04-B.

History: Cr. Register, November, 1979, No. 287, eff. 6-1-80.

PART VI—FUEL SUPPLY SYSTEMS

Ind 23.16 Fuel storage. (1) LIQUEFIED PETROLEUM GAS STORAGE TANKS. All liquefied petroleum gas storage tanks shall be constructed to conform with the applicable sections of Wis. Adm. Code chapter Ind 9, Liquefied Petroleum Gases and Liquefied Natural Gases.

(a) No tanks shall be located inside dwellings.

(b) Gas shutoff valves shall be provided at each tank, at the gas service entry into the dwelling, and at each heating unit.

Register, November, 1979, No. 287
Heating, Ventilating and Air Conditioning Standards

(c) Tanks shall have welded steel supports and be permanently installed on concrete pads or foundations.

(2) OIL STORAGE TANKS. (a) Oil storage tanks on the inside of any dwelling shall be located at the same level as the furnace it serves.

(b) The total storage capacity inside any dwelling unit shall be limited to 550 gallons in one tank, or not more than 275 gallons in each of 2 storage tanks cross-connected to a single burner.

(c) Underground tanks shall be constructed of steel or other approved noncombustible material, provided the material is compatible with fuel oil.

(d) Storage of fuel oil above ground shall not be in excess of 550 gallons. Storage tanks installed outside and above ground shall be installed on a firm and level foundation.

(e) The fuel oil tank shall be equipped with a fill pipe, vent pipe, oil gauge, oil filter and shutoff valve. The vent pipe and fill pipe shall terminate outside of the dwelling and be located at least 2 feet from any opening. The fill pipe shall be at least 2 inches in diameter and the vent pipe shall be at least 1¼ inches in diameter. The vent pipe and fill pipe shall be provided with a weatherproof cap.

Note: The department will accept installations which conform with NFPA standard No. 31, Oil-Burning Equipment.

(3) GAS PIPING. (a) *Materials.* Gas piping materials shall be black IPS wrought iron or steel or other approved piping or tubing and fittings designed for use with fuel gas. Gas valves and connections shall be approved types designed for use with fuel gas.

(b) *Piping support.* Gas piping shall be supported by metal straps or hooks spaced not more than 10 feet apart.

(4) SHUTOFF AND CONTROL DEVICES. (a) An accessible approved shutoff valve shall be installed ahead of the union or other connection in the fuel piping. Service valves on gas-fired equipment shall be located between 4 and 6 feet above the floor.

(b) Automatic gas-burning heating appliances shall be equipped with listed devices which will shut off the gas to the pilot light and main burner(s) in the event of pilot failure.

(c) Liquid fuel-burning appliances shall be equipped with primary safety controls which will shut off the flow of fuel to the burner(s) in the event of ignition failure.

Note: The department will accept installations conforming to NFPA standard No. 54, National Fuel Gas Code.

History: Cr. Register, November, 1979, No. 287, eff. 6-1-80.

PART VII—EQUIPMENT LOCATION AND OPERATION

Ind 23.17 **Equipment location.** (1) **OUTDOOR EQUIPMENT.** Outdoor equipment shall be located so as to not restrict the air flow or recirculation of air. Outdoor equipment so located as to be subject to damage shall be protected.

Register, November, 1979, No. 287
Heating, Ventilating and Air Conditioning Standards

Ind 23

(2) **INDOOR EQUIPMENT.** All indoor equipment shall be installed with a minimum of 24 inches of clearance for service.

History: Cr. Register, November, 1979, No. 287, eff. 6-1-80.

Ind 23.18 Operation. (1) **INSTRUCTIONS.** Written instructions shall be provided the owner for the operation and maintenance of the system and equipment.

(2) **FINAL TEST REQUIRED.** The installer shall test and balance every heating, ventilating and air conditioning system.

History: Cr. Register, November, 1979, No. 287, eff. 6-1-80.