

APPENDIX A

The material contained in the appendix is for clarification purposes only. The notes, illustrations, etc. are numbered to correspond to the number of the rule as it appears in the text of the code.

A-50.10 to 50.25 FORMS. The forms on the following 10 pages (SBD-2; SBD-8, SBD-8A and SB-8-B; SBD-118; SBD-198; SBD-224; SBD-5686; and SBD-9720) are referred to in ss. ILHR 50.18, 50.25, 50.12, 50.14, 50.18, 50.12 and 50.10, respectively. Copies of these forms are

available from the Division of Safety and Buildings, P.O. Box 7969, Madison, Wisconsin 53707.

A-50.21 CERTIFIED MUNICIPALITIES. The following municipalities have been certified by the department to review plans and conduct inspections under s. ILHR 50.21. These lists are current as of the date of printing this code. Additions and deletions may occur during the effective period of this code. For information regarding the current status of a municipality, call 608-267-7586.

FIRST CLASS CITIES

Milwaukee

COUNTIES

Eau Claire

CITIES

| | | | |
|---------------|-------------|--------------|---------------|
| Antigo | Glendale | Middleton | Stevens Point |
| Appleton | Green Bay | Muskego | Sun Prairie |
| Augusta | Greenfield | Neenah | Superior |
| Beloit | Janesville | New Berlin | Two Rivers |
| Brookfield | Kaukauna | New Richmond | Waukesha |
| Burlington | Kenosha | Oak Creek | Waupun |
| Cudahy | La Crosse | Oconomowoc | Wausau |
| Delafield | Lake Geneva | Oshkosh | Wauwatosa |
| Eau Claire | Madison | Racine | West Allis |
| Fond du Lac | Manitowoc | Rhineland | West Bend |
| Fort Atkinson | Marshfield | Seymour | Wisconsin |
| Franklin | Mequon | Sheboygan | Rapids |

VILLAGES

| | | | |
|------------|-------------|---------------|-----------|
| Clinton | Grafton | Johnson Creek | Sussex |
| Dousman | Hartland | Plover | Walworth |
| Elm Grove | Hortonville | Shicton | Waterford |
| Fall Creek | | | |

TOWNS

| | | |
|-------------------------|---------------------|------------------------|
| Bloomfield (Walworth) | Grand Rapids (Wood) | Plover (Portage) |
| Delavan (Walworth) | Hull (Portage) | Sugar Creek (Walworth) |
| Geneva (Walworth) | LaGrange (Walworth) | Waterford (Racine) |
| Grand Chute (Outagamie) | Norway (Racine) | Waukesha (Waukesha) |

Wisconsin Department of Industry,
Labor & Human Relations

INSPECTION REPORT AND ORDERS

Safety and Buildings Division
P.O. Box 7969, Madison, WI 53707

An inspection of the occupancy shown below discloses violations of orders of the Dept. of Industry, Labor and Human Relations promulgated under authority of Chapter 101, Wis. Stats. SEE REVERSE SIDE FOR APPLICABLE WISCONSIN STATUTES. Report when orders are completed. Avoid delay. Forfeiture for unresolved violations are \$10.00 to \$100.00 each day for each violation. Keep the Department informed.

"Failure of an employer to reasonably enforce compliance by employees with such statute or order of the Department shall constitute failure by the employer to comply with such statute or order." (s. 102.57, Wis. Stats.)

| | | | |
|-----------------|--------------------|--|--------|
| Inspection Date | Plan/Report Number | File Number | Page |
| | | Inspection Type | |
| | | Located At (number and street address) | |
| | | City | County |
| | | Violations Explained To | |
| | | Compliance Date | |

| Note | Item | Orders and Requirements | ✓ Done | X Not Done |
|------|------|-------------------------|--------|------------|
| | | SAMPLE | | |

| | |
|-------------|--|
| Deputy Name | Deputy's Office Hours and Telephone Number |
|-------------|--|

SBD-2 (R. 09/90)

Wisconsin Department of Industry,
Labor and Human Relations

**PETITION FOR VARIANCE
APPLICATION**

Safety and Buildings Division
P.O. Box 7969
Madison, Wisconsin 53707
(608) 266-1542

Please type or print.

| OFFICE USE ONLY | Amount Paid | Receipt Number | Petition No. | F Number |
|-------------------------|---------------------------|----------------|--------------------------------------|----------|
| Owner/Petitioner's Name | Building Or Project | | Agent, Architect or Engineering Firm | |
| Company | Tenant's Name, If Any | | Street Address | |
| Street Address | Location - Street Address | | City, State, Zip Code | |
| City, State, Zip Code | City, County | | Telephone Number () | |
| Telephone Number | Plan Number, If Known | | Contact Person's Name | |

1. The rule being petitioned reads as follows (cite specific rule number and language; one rule per application):

2. The rule being petitioned cannot be entirely satisfied because:

SAMPLE

3. The following alternative(s) and supporting information are proposed as a means of providing an equivalent degree of health, safety or welfare as addressed by the rule:

Note: Please attach any pictures, plans, sketches or required position statements.

VERIFICATION BY OWNER - PETITION IS VALID ONLY IF NOTARIZED WITH AFFIXED SEAL AND ACCOMPANIED BY REVIEW FEE
See Section ILHR 2.52 for complete fee information

Note: Petitioner must be the owner of the building or project. Tenants, agents, designers, contractors, attorneys, etc., shall not sign petition unless Power of Attorney is submitted with the Petition For Variance Application

_____, being duly sworn, I state as petitioner that I have read the foregoing
Petitioner's Name (type or print)
petition and I believe it is true and that I have significant ownership rights to the subject building or project.

| | | | |
|-------------------------|--|---------------|---------------------------|
| Petitioner's Signature: | Subscribed And Sworn To Before Me This Date: | Notary Public | My Commission Expires On: |
|-------------------------|--|---------------|---------------------------|

Wisconsin Department of Industry,
Labor and Human Relations

POSITION STATEMENT

Safety and Buildings Division
P.O. Box 7969
Madison, Wisconsin 53707

Instructions: This form is to be completed by the fire department chief or designee and sent promptly to the address shown above. Please print or type all responses.

| | | |
|-----------------------|--|--------------------------------------|
| Owner's Name | Building Occupancy Or Facility Description | Agent, Architect or Engineering Firm |
| Company | Tenant's Name, If Any | Street Address |
| Street Address | Location - Street Address | City, State, Zip Code |
| City, State, Zip Code | City, County | Telephone Number () |
| Telephone Number | Plan Number, If Known | Contact Person's Name |

1. I have read the application for variance of rule ILHR _____

2. I recommend (check appropriate box): Approval Conditional Approval Denial No Comment *

3. Explanation For Recommendation:

SAMPLE

* If desired, Fire Departments may indicate "No Comment" on non-fire safety issues such as sanitation, energy conservation, barrier free environments, etc.

4. I find no conflict with local rules and regulations.
 I find the petition is in conflict with local rules and regulations.

Explanation:

Fire Department Name And Address:

Name Of Fire Chief Or Designee (type or print):

Telephone Number

Signature Of Fire Chief Or Designee:

Date Signed:

BUILDING/STRUCTURE/HVAC PLANS APPROVAL APPLICATION

- Complete Both Sides -

Wisconsin Department of Industry,
Labor & Human Relations
Safety & Buildings Division
Bureau of Buildings & Structures

Scheduling Information - complete
when calling to schedule review:

E-File _____
Plan No. _____

INSTRUCTIONS: Fill in all applicable data. **Caution:** Failure to complete the form entirely may cause additional delay. Submittal of this Plans Approval Application is required for each building. Submit this form with at least 4 sets of plans which include details and data as required by ILHR 50.12. Plans may be submitted to any of the plan review offices listed on the reverse side. Projects are scheduled for review. Please call the selected office prior to submittal. Any components submitted independently from the building plans must be submitted to the office which did the project's initial review.

| | | | | | |
|--|--|--|--|--|--|
| 1. Owner Information | | 2. Project Information | | 3. Building or Structure Designer Information | |
| Name _____ | | Building Occupancy Chapter(s) And Use: _____ | | Designer _____ Registration # _____ | |
| Company Name _____ | | Tenant Name (if any) _____ | | Design Firm _____ | |
| Number & Street _____ | | Building Location (number & street) _____ | | Number & Street _____ | |
| City, State, Zip Code _____ | | <input type="checkbox"/> City <input type="checkbox"/> Village <input type="checkbox"/> Township Of _____ | | City, State, Zip Code _____ | |
| Contact Person _____ | | County Of _____ | | Contact Person _____ | |
| Telephone Number () _____ | | Property ID No. (tax parcel no. - contact county) _____ | | Telephone Number () _____ Fax Number () _____ | |
| Fax Number () _____ | | Government Owned <input type="checkbox"/> Yes <input type="checkbox"/> No Government Leased Or Operated <input type="checkbox"/> Yes <input type="checkbox"/> No | | Return Plans To: <input type="checkbox"/> Owner <input type="checkbox"/> Designer <input type="checkbox"/> Other _____ | |
| 4. Building History | | 5. Construction Class Requested | | 6. HVAC Designer Information | |
| Previous Owner(s) (if any) _____ | | <input type="checkbox"/> 1. Fire Resistive Type A <input type="checkbox"/> 2. Fire Resistive Type B <input type="checkbox"/> 3. Metal Frame - Protected <input type="checkbox"/> 4. Heavy Timber <input type="checkbox"/> 5A. Exterior Masonry - Protected <input type="checkbox"/> 5B. Exterior Masonry - Unprotected <input type="checkbox"/> 6. Metal Frame - Unprotected <input type="checkbox"/> 7. Wood Frame - Protected <input type="checkbox"/> 8. Wood Frame - Unprotected | | Designer _____ Registration # _____ | |
| Previous Plan or File No. _____ | | If plans do not show compliance with requested Construction class but are approvable at a lower class, do you wish approval at the lower class? <input type="checkbox"/> Yes <input type="checkbox"/> No | | Design Firm _____ | |
| Variance No. _____ Preliminary No. _____ | | | | Number & Street _____ | |
| Other Information (previous use, last submission) _____ | | | | City, State, Zip Code _____ | |
| | | | | Contact Person _____ | |
| | | | | Telephone Number () _____ Fax Number () _____ | |
| 7. Building Information | | 8. Submittal Request | | 9. Supervising Professional Information | |
| <input type="checkbox"/> Complete Sprinkler - NFPA _____ <input type="checkbox"/> Partial Sprinkler - NFPA _____ <input type="checkbox"/> Unlimited Area <input type="checkbox"/> Fire Alarm <input type="checkbox"/> Emergency Power <input type="checkbox"/> Smoke Detection <input type="checkbox"/> Hazard Enclosure | | Project _____ Review Requested _____ <input type="checkbox"/> New <input type="checkbox"/> Footing/Foundation <input type="checkbox"/> Alteration <input type="checkbox"/> Building <input type="checkbox"/> Addition <input type="checkbox"/> Permission To Start <input type="checkbox"/> Revisions <input type="checkbox"/> HVAC <input type="checkbox"/> Use Change <input type="checkbox"/> ILHR 70 Hist Code <input type="checkbox"/> Truss <input type="checkbox"/> Variance <input type="checkbox"/> Precast <input type="checkbox"/> Preliminary <input type="checkbox"/> Structural <input type="checkbox"/> Canopy <input type="checkbox"/> Laminated Wood <input type="checkbox"/> Bleacher <input type="checkbox"/> Metal Building <input type="checkbox"/> Tower <input type="checkbox"/> Joist/Girder <input type="checkbox"/> Other _____ | | <input type="checkbox"/> For Building <input type="checkbox"/> Same As Building Designer <input type="checkbox"/> For HVAC <input type="checkbox"/> Same As HVAC Designer Supervising Prof (if different from designer) _____ | |
| Total Number of Stories _____ | | | | Registration # _____ | |
| Building Footprint Area _____ sq ft | | | | Number & Street _____ | |
| Soil Bearing Capacity _____ psf <input type="checkbox"/> Presumed <input type="checkbox"/> Verified | | | | City, State, Zip Code _____ | |
| | | | | Telephone Number _____ | |
| 10. Related Business Systems - Please call the respective Program for clarification and plan submittal requirements. | | | | | |
| <input type="checkbox"/> Elevators (608-267-3576) includes: <input type="checkbox"/> Passenger elevator meeting ILHR 18 req. <input type="checkbox"/> Freight elevator meeting ILHR 18 req. <input type="checkbox"/> Part 5 lift (residential type) <input type="checkbox"/> Part 20 lift (wheelchair lift) | | <input type="checkbox"/> Flammable/Combustible Liquid (608-267-1379) Will any portion of this building be used for storage or dispensing of flammable / combustible liquids as covered by ILHR 107 <input type="checkbox"/> Yes <input type="checkbox"/> No | | <input type="checkbox"/> Boiler/Pressure Vessel (608-266-1904) <input type="checkbox"/> Mechanical Refrigeration/AC (608) 266-1904 <input type="checkbox"/> Plumbing (608-266-3815) Sewer: <input type="checkbox"/> Municipal <input type="checkbox"/> Private Sewage System | |

11. Calculation of Fees

Area: The area of a floor is the area bounded by the exterior surface of the building walls or the outside face of columns where there is no wall. Area includes all floor levels such as subbasements, basements, ground floors, mezzanines, balconies, lofts, all stories and all roofed areas including porches and garages, except for cantilevered canopies on the building wall. Use the roof area for free standing canopies. Total area is the summation of all floor areas.

Attach a separate sheet if necessary for the calculations below:

| Floor Level (specify) | Length | X | Width | = | Area |
|-----------------------|--------|---|-------|------------|---------|
| _____ | _____ | X | _____ | = | _____ |
| _____ | _____ | X | _____ | = | _____ |
| _____ | _____ | X | _____ | = | _____ |
| _____ | _____ | X | _____ | = | _____ |
| _____ | _____ | X | _____ | = | _____ |
| _____ | _____ | X | _____ | = | _____ |
| | | | | Total Area | = _____ |

- Project NOT located in certified municipality (go to Fee Schedule Table 2.31-1).
- Project located in certified municipality (go to Fee Schedule Table 2.31-2). (See Fee Schedule for list of certified municipalities.)

| | | | |
|---|-----|----|-------------------|
| <input type="checkbox"/> Building and HVAC | Fee | \$ | _____ |
| <input type="checkbox"/> Building Only | Fee | \$ | _____ |
| <input type="checkbox"/> HVAC Only | Fee | \$ | _____ |
| <input type="checkbox"/> Revision To Previously Approved Plan | Fee | \$ | _____ |
| <input type="checkbox"/> Permission To Start | Fee | \$ | _____ |
| <input type="checkbox"/> Pre-July 1992 Building Components | Fee | \$ | _____ |
| <input type="checkbox"/> Other | Fee | \$ | _____ |
| | | | Total Fee = _____ |

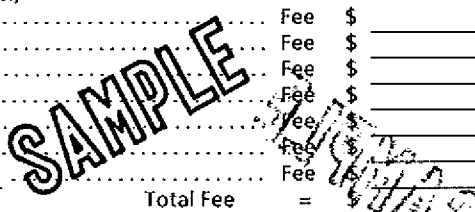

12. OWNER'S STATEMENT (ILHR 50.11): I request that plans be reviewed for compliance with the code requirements set forth in Chapters ILHR 50-64 of the rules of the department. I recognize that I am responsible for compliance with all code requirements and any conditions of plan approval. If this building exceeds 50,000 cubic feet in total volume, I will retain a supervising professional as required by ILHR 50.10 throughout construction to project completion and the filing of a Completion Statement by the supervising professional.

Owner's Signature: _____ Name & Title _____
Original Print

13. DESIGNER'S STATEMENT: DESIGN (ILHR 50.07-50.09) if this building, following construction of this project, contains more than 50,000 cubic feet in total volume, plans are required to be prepared, signed, sealed and dated by a Wisconsin registered engineer or architect (ILHR 50.07(2)). Signatures and seals shall be original.

The department expects, and requires, that the project designer review individual component submittals for compliance with the general design concept. The project designer, and department, will rely on the seal of the component designers for compliance with the codes as they apply to their designs.

- Total cubic foot volume of the building upon completion of this project: Less Than 50,000 50,000 or Greater
- Design loads have been indicated on the plans. Yes N/A
- Firewall schematic plan has been included. Yes N/A
- All applicable items required by ILHR 50.12 have been included. Yes N/A

I certify that the submitted plans were prepared under my supervision, are accurate, and to the best of my knowledge comply with the applicable codes of the Department of Industry, Labor and Human Relations.

| | | | |
|---|-------------|-------------------------------------|-------------|
| Original Signature of Building Designer (Building Submittal) | Date Signed | Original Signature of HVAC Designer | Date Signed |
| Original Signature of Building Designer (Component Submittal) | Date Signed | Name of Component Design Firm | |

14. SUPERVISING PROFESSIONAL'S STATEMENT: (ILHR 50.10) I have been retained by the owner as the supervising professional per ILHR 50.10 for the performance or supervision of reasonable on-the-site observations to determine if the construction is in substantial compliance with the approved plans and specifications. Upon completion of construction, I will file a written statement with the department certifying that, to the best of my knowledge and belief, construction has or has not been performed in substantial compliance with the approved plans and specifications.

| | | | |
|---|-------------|---|-------------|
| Original Signature of Professional Supervising The Building | Date Signed | Original Signature of Professional Supervising The HVAC | Date Signed |
|---|-------------|---|-------------|

| | | | | |
|---|--|---|---|--|
| Hayward Office 209 W. 1st Street Rt 8, Box 8072 Hayward, WI 54843 Phone (715) 634-4870 Fax (715) 634-5150 | La Crosse Office 2226 Rose Street La Crosse, WI 54603 Phone (608) 785-9334 Fax (608) 785-9330 | Madison Office 201 E. Washington Ave. P.O. Box 7969 Madison, WI 53707 Phone (608) 266-8735 Fax (608) 267-9566 | Shawano Office 1053A E. Green Bay Street P.O. Box 434 Shawano, WI 54166 Phone (715) 524-3626 Fax (715) 524-3633 | Waukesha Office 401 Pilot Court, Suite C Waukesha, WI 53188 Phone (414) 548-8600 Fax (414) 548-8614 |
|---|--|---|---|--|

Wisconsin Department of Industry,
Labor and Human Relations

PERMISSION TO START CONSTRUCTION

Safety and Buildings Division

**NOTE: This permission is applicable only to projects
having below grade foundation work.**

Additional fees are required. Contact one of the locations listed below for more information.

HAYWARD OFFICE
Route 8
P.O. Box 8072
Hayward, WI 54843
Tele: (715) 634-4870
FAX: (715) 634-5150

LA CROSSE OFFICE
2226 Rose Street
La Crosse, WI 54603
Tele: (608) 785-9334
FAX: (608) 785-9330

MADISON OFFICE
201 E. Washington Ave.
PO. Box 7969
Madison, WI 53707
Tele: (608) 266-8735
FAX: (608) 267-9566

SHAWANO OFFICE
1053A E. Green Bay Street
P.O. Box 434
Shawano, WI 54166
Tele: (715) 524-3626
FAX: (715) 524-3633

WAUKESHA OFFICE
401 Pilot Court
Waukesha, WI 53188
Tele: (414) 548-8600
FAX: (414) 548-8614

Project Location:

Street: _____ E-File: _____

City: _____ Plan Number: _____

County: _____ Date Plans Rec'd: _____

Occupancy: _____

SAMPLE

We, the undersigned, request to begin footing and foundation work prior to approval of the plans in accordance with ILHR 50.14.

Plans have been submitted to the Department of Industry, Labor and Human Relations, Safety and Buildings Division, and all information requested by Code ILHR 50.12 or ILHR 50.13 has been included with the submittal.

We have reviewed the specific code requirements for the building or structure and its use, as set forth in ILHR 50-64, and, where applicable, have shown compliance on the drawings.

We agree to make any changes required after the plans have been reviewed and to remove or replace non-code complying parts of the foundation and/or footings.

We agree to proceed with the footings and foundation only and will not continue with the remainder of the building or structure until approval has been received.

We understand that, prior to the start of construction, a Building Permit must be obtained from the local authorities having jurisdiction in accordance with their laws and ordinances.

We understand that if this project is in an unsewered area, a sanitary permit must be obtained prior to the issuance of a local building permit (ss 101.12 (3) (h)).

Owner's Signature: _____
(Original Signature in Ink)

Date Signed: _____

Owner's Name: _____

Street: _____

City: _____ State: _____ Zip: _____

Designer's Signature: _____
(Original Signature in Ink)

Date Signed: _____

Designer's Name: _____

Street: _____

City: _____ State: _____ Zip: _____

Department Action: Approved Not Approved

Review Comments:

Reviewed By: _____ Today's Date: _____

Wisconsin Department of Industry
Labor & Human Relations

INSPECTION PROGRESS REPORT

Safety and Buildings Division
P.O. Box 7969, Madison, WI 53707

| | | |
|-------------|--|--------------------|
| RE: | File Number | Plan No. |
| | E- | |
| | Inspection Date: | Person Contacted |
| | No. 1. | |
| | 2. | |
| | 3. | |
| | Bldg. Final | |
| H & V Final | | |
| Other Final | | |
| TO: | Compliance Date: | |
| | Office Instruction (Check one): | Supervisory Review |
| | <input type="checkbox"/> Voluntary Compliance <input type="checkbox"/> Process SB-2 <input type="checkbox"/> Violations explained to owner | |

| INSPECTION | | | | INSPECTION FINDINGS |
|---|---|---|-------|--|
| 1 | 2 | 3 | Final | |
| ✓ Order Corrected X Order Not Corrected | | | | Items listed below should be corrected before the next inspection or final inspection. These items are violations of the Building Code sections noted. |
| | | | | |
| <p style="font-size: 48pt; transform: rotate(-30deg); opacity: 0.5;">SAMPLE</p> | | | | |

| | |
|---|---|
| Owner's Name and Address (if different from above): | Deputy's Name: |
| | Deputy's Signature: |
| | Deputy's Office Hours and Telephone Number: |

DEPARTMENT OF INDUSTRY, LABOR AND HUMAN RELATIONS
SAFETY & BUILDINGS DIVISION
BUREAU OF BUILDINGS AND STRUCTURES
201 E. WASHINGTON AVE.
P.O. Box 7969
MADISON, WISCONSIN 53707

FILE NO. E- _____
PLAN NO. _____
VOLUME _____

PLAN EXAMINATION LETTER

DATE: _____

Note: This Preprinted Plan Review letter is being used at the discretion of the plan examiner to expedite the plan review. This form serves as the review correspondence.

Occupancy
Tenant
Owner
Location
Municipality
County

Supervising Professional

Plans have been reviewed for compliance with the important code requirements in Chapters ILHR 50 through 64 of the rules of the Department.

The _____ plans are:

| | | |
|---|-----------------------------------|---------------------------------------|
| <input type="checkbox"/> CONDITIONALLY APPROVED | <input type="checkbox"/> WITHHELD | <input type="checkbox"/> NOT APPROVED |
|---|-----------------------------------|---------------------------------------|

If the plans are stamped "CONDITIONALLY APPROVED" construction may proceed, but all items that are required to be changed by this letter must be corrected before commencing that part of the work.

You are advised that the owner as defined in Chapter 101.01(2)(i) of the Wisconsin State Statutes is responsible for all code requirements not specifically cited. The building will be inspected during and after construction. The owner shall notify the state building inspector and the local building inspector before taking possession of the building.

ILHR 50.15 EVIDENCE OF APPROVAL. The architect, professional engineer, designer, builder or owner shall keep at the building, one set of plans bearing the stamp of approval.

This plan has not been reviewed for compliance with Chapters ILHR 82 through 86, the Plumbing Rules of the Department.

THIS BUILDING HAS BEEN CLASSIFIED AS NO. _____ CONSTRUCTION. SPRINKLERED UNLIMITED AREA

COMMENTS:

Plans for the following shall be submitted to this office and approved prior to construction of that component.

Trusses Precast Concrete Heat & Vent Systems Illumination _____

State Inspector - Region _____ Area Code _____
Local Inspector - _____ Phone (____) _____

BY: _____
PLAN EXAMINER
Phone _____

Compliance Statement

This form is required to be submitted by the architect, engineer, or HVAC designer (supervising professional) observing construction of projects within buildings with total volumes exceeding 50,000 cubic feet and construction of antennas, towers and bleachers (ILHR 50.10). Failure to submit this form may result in penalties as specified in ILHR 50.26 and/or local ordinances.

General Instructions: Prior to the initial occupancy of new buildings or additions and the final occupancy of altered existing buildings, submit this completed and signed form to:

The municipal building inspection office and
DILHR, Safety and Buildings, P.O. Box 7969, Madison, WI 53707

1. PROJECT INFORMATION: (Use the DILHR or municipal project label, or type or print the information.)

| | Owner Information | Project Information |
|---|---|---|
| L | Name | Building Occupancy Chapter(s) & Use |
| A | Company Name | Tenant Name (if any) |
| B | Number and Street | Building Location (number & street) |
| E | City | <input type="checkbox"/> City <input type="checkbox"/> Village <input type="checkbox"/> Town of |
| L | State and Zip Code | County of |
| H | Plan or Reference Number | Property Identification Number |
| E | Name and Registration Number of the Building Supervising Professional | Building Project # |
| R | Name and Registration Number of the HVAC Supervising Professional | HVAC Project # |
| E | | |

2. PURPOSE OF THIS STATEMENT: (Check Box A, B, or C to indicate purpose and complete any other applicable boxes and information. Attach additional pages if necessary.)

Building and HVAC Building Only HVAC Only

Partial Completion _____
Description of Portion Completed

A) Statement of Substantial Compliance

To the best of my knowledge, belief, and based on onsite observation, construction of the following building and/or HVAC items applicable to this project have been completed in substantial compliance with the approved plans and specifications.

BUILDING ITEMS

1. Structural system including submittal and erection of all building components (trusses, precast, metal building, etc.)
2. Fire protection systems (sprinklers, alarms, smoke detectors, fire extinguishers)
3. Exits including exit and directional lights
4. Shaft and stairway enclosures
5. Fire-resistive construction, enclosure of hazards, fire walls, labeled doors, class of construction
6. Sanitation system (toilets, sinks, drinking facilities)
7. Barrier-free access and circulation
8. All conditions of building plan approval and applicable variances

HVAC ITEMS

1. HVAC system including final test (ILHR 64.53)
2. All conditions of HVAC plan approval and applicable variances

The following items are not in compliance and must be addressed: _____

B) Statement of Noncompliance

Due to the following listed violations, this project is not ready for occupancy: _____

C) Supervising Professional Withdrawn From Project Date Withdrawn

(Use A or B above to indicate project status as of this date.)

3. SIGNATURES:

Building Supervising Professional Date HVAC Supervising Professional Date

A-51.01 (12) BUILDING. The intent was to consider permanent awnings as part of a building.

A-51.01 (42) FAMILY. The intent of this definition is to clarify the use of the word "family" in reference to s. ILHR 51.01 (102a); it is not intended as a variance to the definition stated under s. ILHR 51.01 (102a) (b).

A-51.01 (67a) HABITABLE ROOM. It is the intent that rooms designated as recreation, study, den, family room, office, etc. and providing the only space for living and/or sleeping are considered habitable rooms.

A-51.01 (115) SETBACK. The intent was to not include gutters, downspouts, outdoor lighting fixtures, signs and similar attachments as part of a building.

To determine the portion of a wall (A) that is within a distance X from a property line or another building, extend the wall face to its intersection with the property line or other building. Bisect the angle formed by the intersection. Measure X perpendicular to the bisector. Repeat these steps for wall face B.

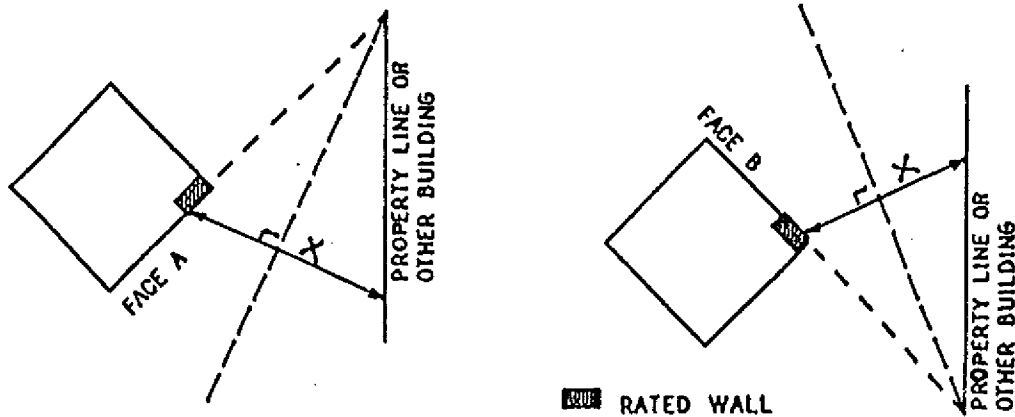

The following sketch shows setback measurements between intersecting or projected intersection of building faces.

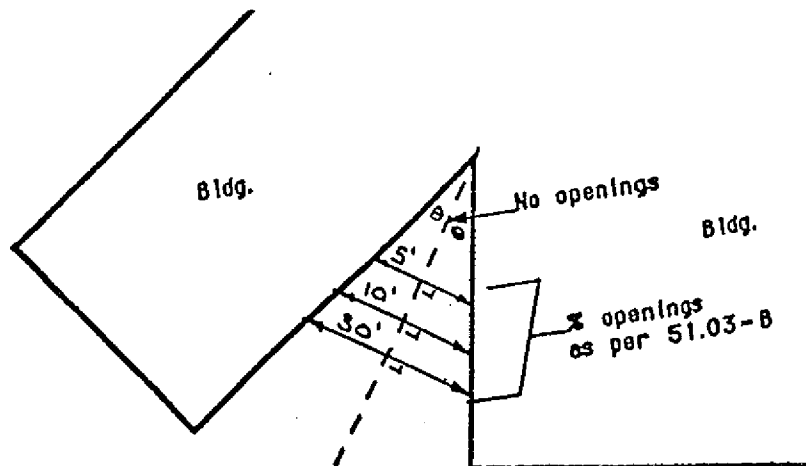

A-51.01 (121) STORIES, NUMBER OF. For further clarification, refer to A-51.02 (14).

A-51.01 (144) WALL (DIVISION).

(a) *Building division wall* is intended to denote a wall constructed in a manner sufficient to meet requirements for a party wall [see "Wall (Party)"] and is acceptable as a dividing wall or enclosing wall when determining the volume of a building as referred to in ss. ILHR 50.07, 50.10 and 50.12.

(b) *Fire division wall* is intended to relate to construction that provides separation between portions of a building to satisfy allowable floor area limitations, separation between 2 classes of construction, or separation of hazardous occupancies. For other separations, see "occupancy separations" and isolation of hazards sections of this code.

A-51.01 (151) WALL (PARTY). It is intended that a property consisting of joining plotted subdivisions owned by one individual, that can be owned by separate individuals, is included in the definition of party wall.

A-51.02 (14) DETERMINATION OF NUMBER OF STORIES. to this rule and the definition of s. ILHR 51.01 (121) Stories, Number of.
The following illustrations are provided to give visual aid

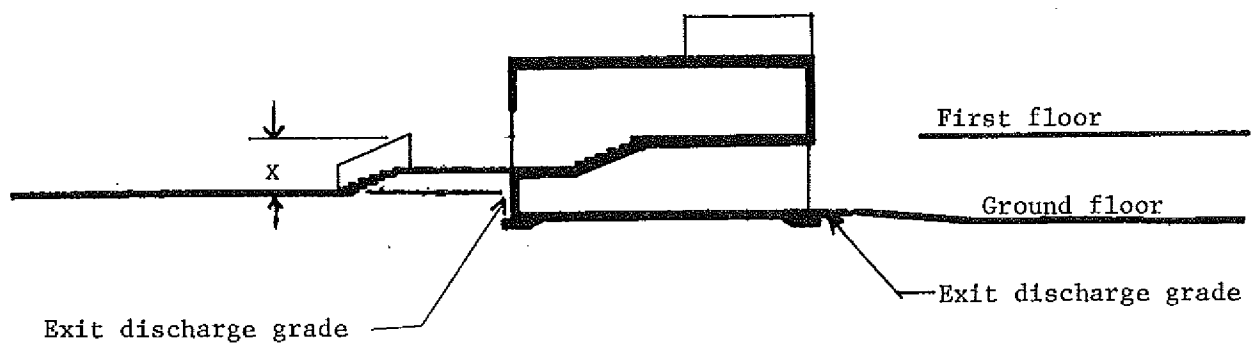

Note: X = 6'-0" (maximum)

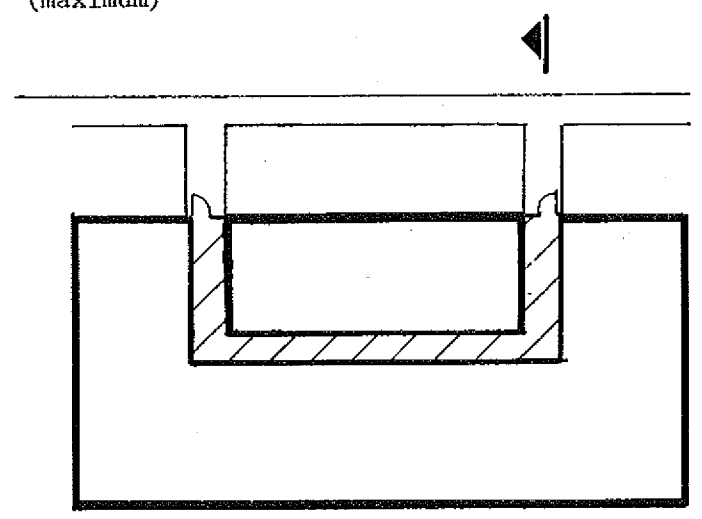

Ground floor

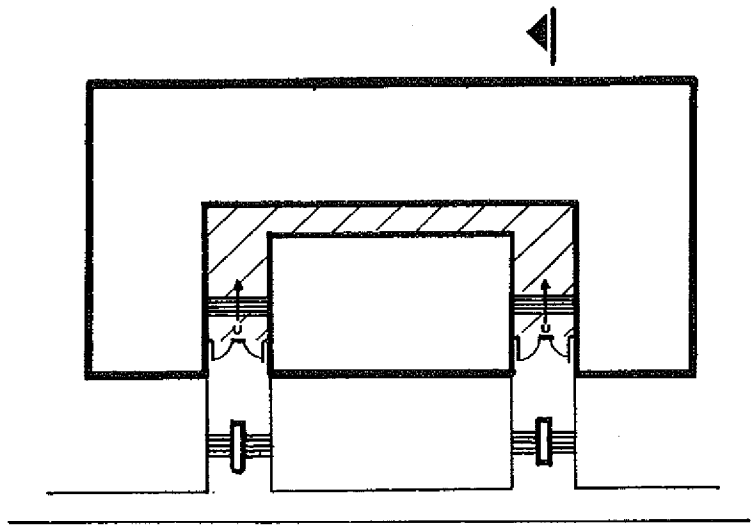

First floor

A-51.03 (5) (a) EXTERIOR MASONRY CONSTRUCTION. The following Figures 1, 2, 3, 4, 5A and 5B illustrate typical details for various wall construction alternatives, which satisfy the intent of this rule for Type 5 — Exterior Masonry Construction.

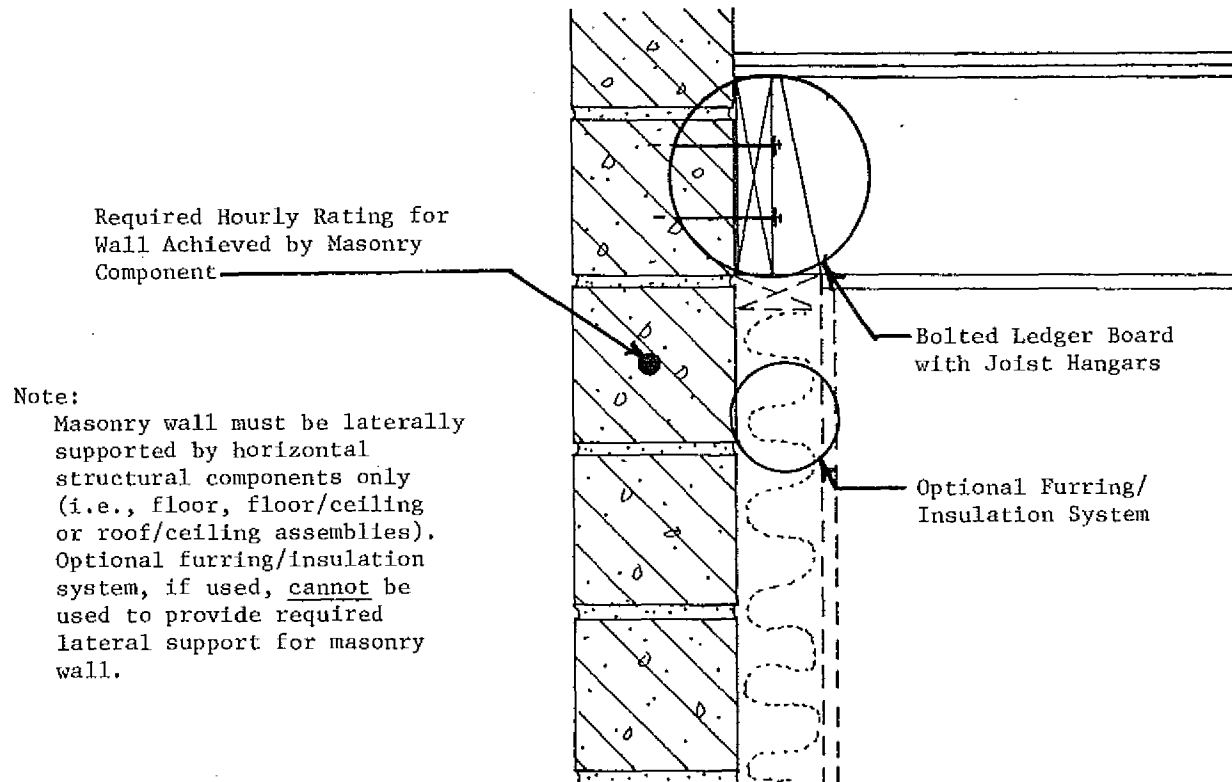

Note:

Masonry wall must be laterally supported by horizontal structural components only (i.e., floor, floor/ceiling or roof/ceiling assemblies). Optional furring/insulation system, if used, cannot be used to provide required lateral support for masonry wall.

FIGURE 1
Single Wythe Masonry Wall
(Bearing Condition)

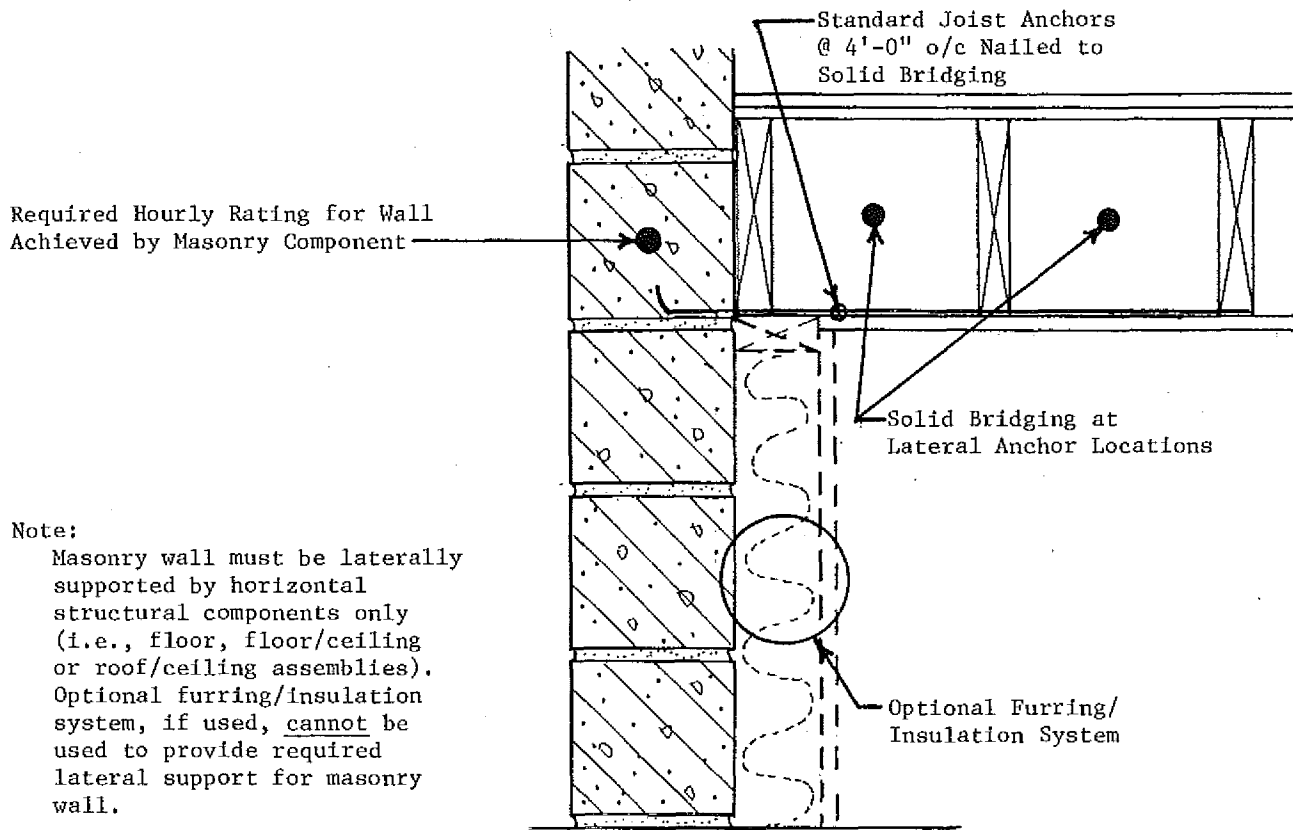

FIGURE 2
Single Wythe Masonry Wall
(Non-Bearing Condition)

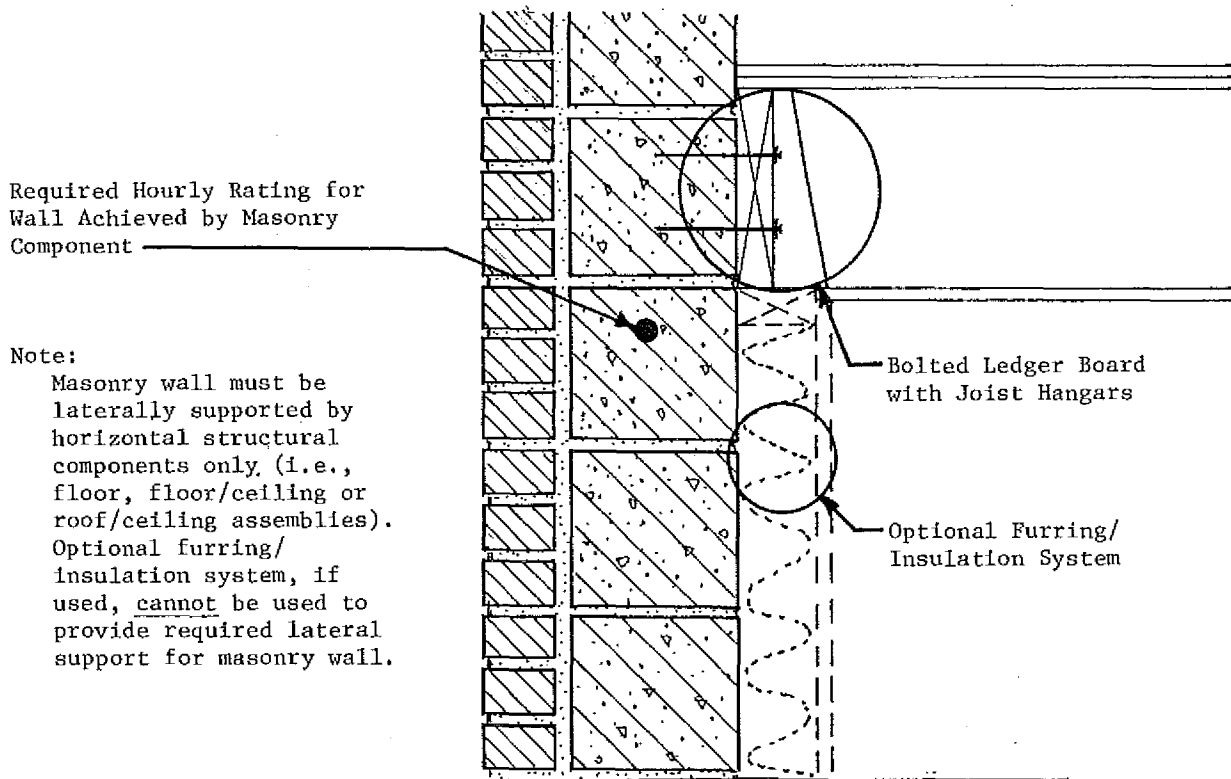

FIGURE 3
Multi-Wythe Masonry Wall
(Bearing Condition)

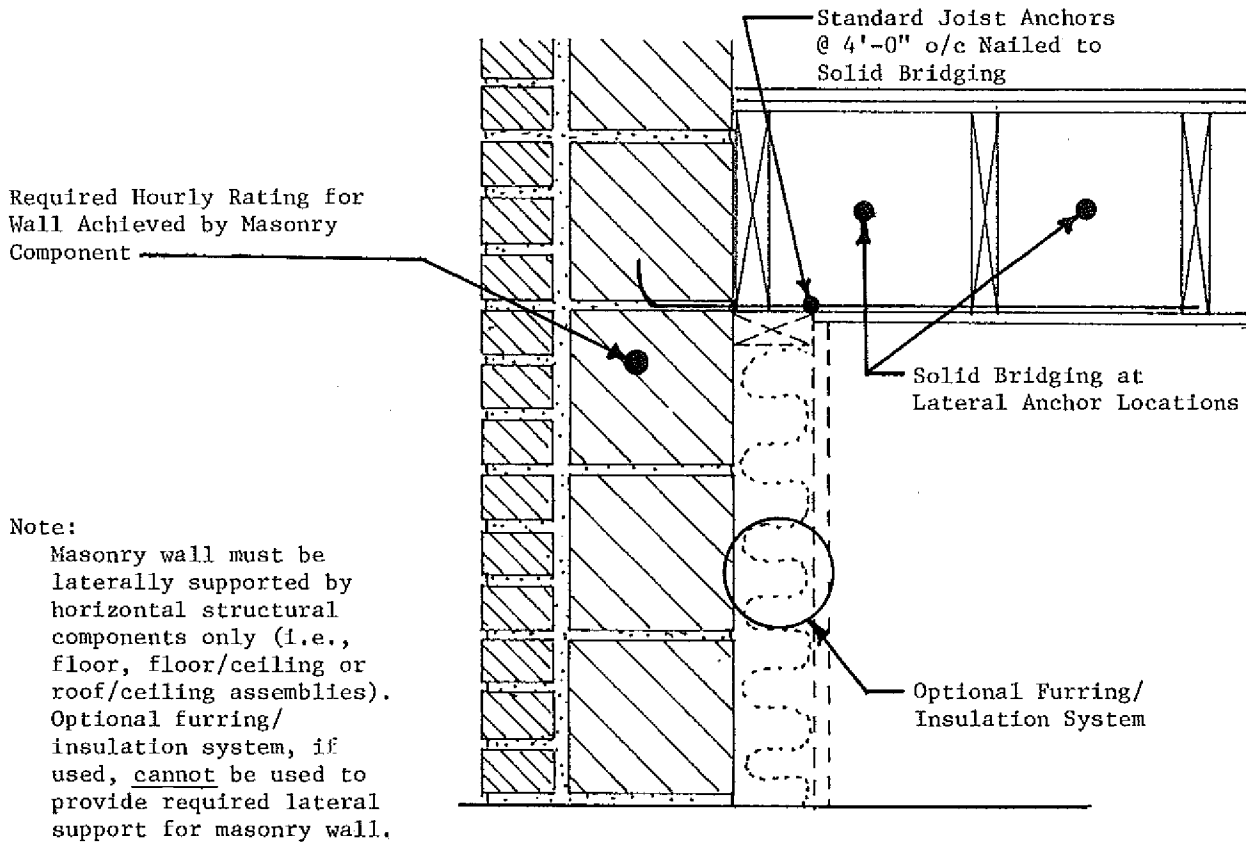

FIGURE 4
Multi-Wythe Masonry Wall
(Non-Bearing Condition)

Note:

Masonry wall must be laterally supported by horizontal structural components only (i.e., floor, floor/ceiling, roof/ceiling assemblies). Masonry cannot rely upon the back-up wall component for lateral support.

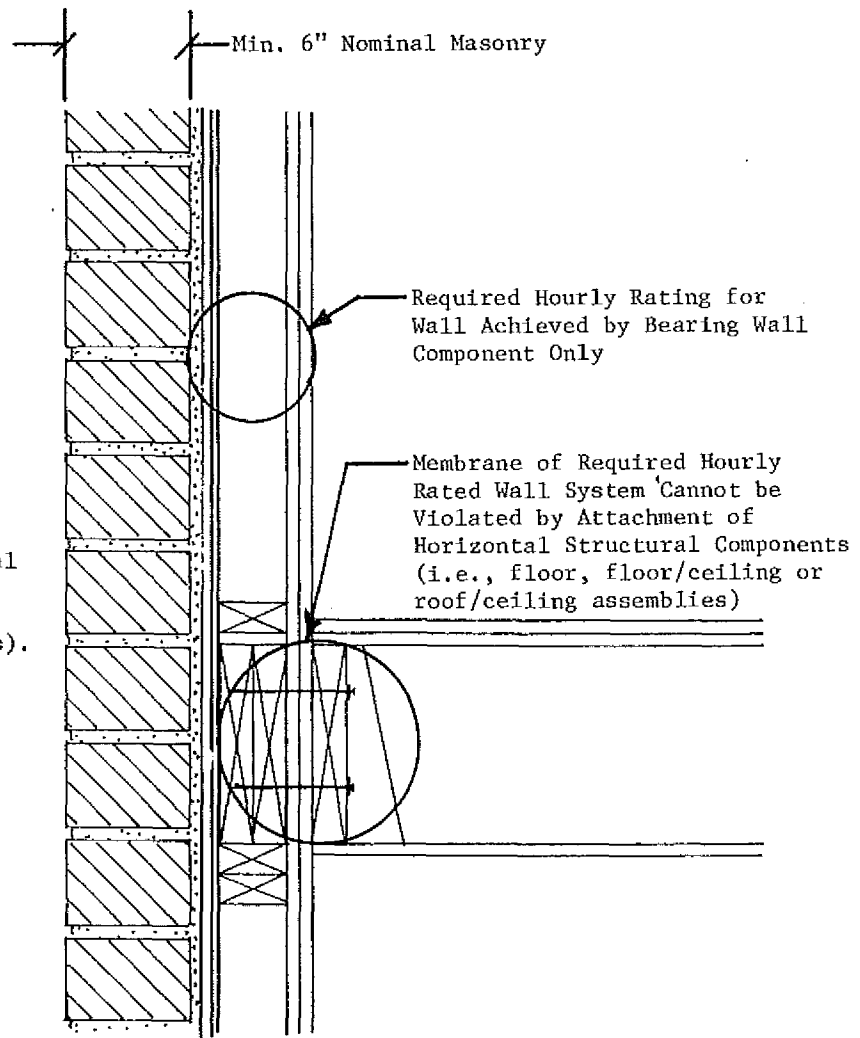

FIGURE 5A
Combination Masonry/Frame Wall
(Bearing and Non-Bearing Condition)

Note:

Masonry wall must be laterally supported by horizontal structural components only (i.e., floor, floor/ceiling or roof/ceiling assemblies). Masonry cannot rely upon the back-up wall component for lateral support.

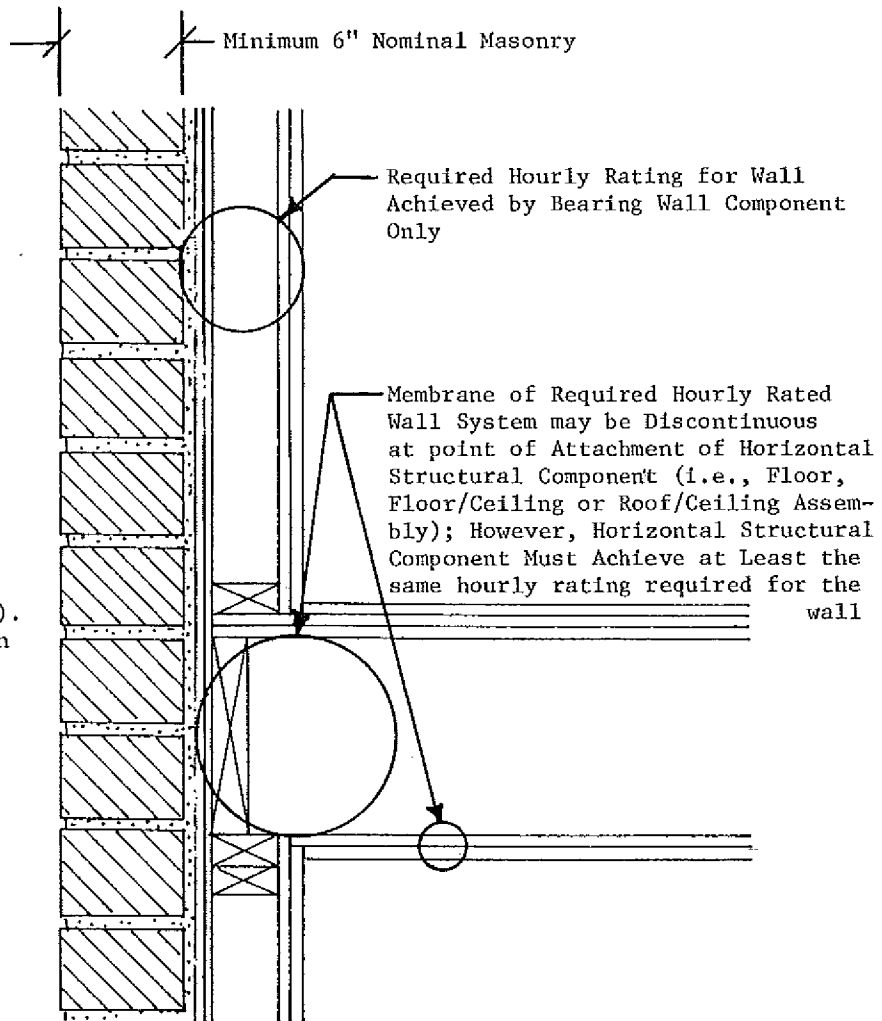

FIGURE 5B
Combination Masonry/Frame Wall
(Bearing and Non-Bearing Condition)

A-51.044 APPROVED TESTING LABORATORIES. The following laboratories have been approved by the department under s. ILHR 50.19. This list is current as of the date of printing this code. Additions and deletions may occur dur-

ing the effective period of this code. For information regarding the current status of a testing laboratory, call 608-266-1542.

TABLE A-51.044
APPROVED TESTING LABORATORIES

| Name of Recognized Laboratory | ASTM STANDARD TEST | | | | | | |
|--|--------------------|-------|-------|-------|-------|-------|-------|
| | E-84 | E-108 | E-119 | E-136 | E-152 | E-163 | E-648 |
| 1. Applied Research Laboratories, Inc., Miami, FL | X | X | X | X | X | X | X |
| 2. Commercial Testing Co., Inc., Dalton, GA | X | — | X | X | X | — | X |
| 3. Construction Technologies, Laboratories, Skokie, IL | — | — | X | — | — | — | — |
| 4. Factory Mutual Research Corp., Norwood, MA | X | X | X | X | X | X | X |
| 5. Forest Product Laboratories, Madison, WI* | — | — | X | — | X | — | X |
| 6. Hardwood Plywood Mfgs. Assoc., Reston, VA | X | — | — | — | — | — | X |
| 7. Northwest Testing Lab., Inc., Portland, OR | — | — | X | — | X | X | — |
| 8. Omega Point Laboratories, Inc. San Antonio, TX | X | X | X | X | X | X | X |
| 9. PFS Corporation Madison, WI | X | — | X | — | X | — | — |
| 10. Radco Carson, CA | X | — | — | — | — | — | — |
| 11. Southwest Research Inst., San Antonio, TX | X | X | X | X | X | X | X |
| 12. Underwriters Lab., Inc., Northbrook, IL | X | X | X | X | X | X | X |
| 13. Univ. of Calif. — Berkeley, Richmond, CA | — | X | X | — | — | — | — |
| 14. U.S. Testing Co. Fairfield, NJ | X | X | — | X | — | — | X |
| 15. U.S. Testing Co. Los Angeles, CA | X | X | — | X | — | — | X |
| 16. VTEC, Inc., Bronx, NY | X | X | X | X | — | — | X |
| 17. Warnock Hersey Intl-Inc., Pittsburg, CA | X | X | X | — | X | X | — |

* Reference based on research and development data. Facility is not available for conducting routine rating tests.

A-51.15 (6) EXAMPLE TO DETERMINE TOTAL AGGREGATE EXIT WIDTH.

| | |
|----------------|-----|
| 5 | 300 |
| 4 | 400 |
| 3 | 500 |
| 2 | 200 |
| 1 | 600 |
| B ₁ | 100 |
| B ₂ | 300 |
| B ₃ | 400 |

Type No. 1 sprinklered construction.

Aggregate exit width required from a floor into the stairwell is 30 inches per 100 people on that floor; i.e.,

5th floor to stairwell = $3 \times 30 = 90''$

4th floor to stairwell = $4 \times 30 = 120''$

3rd floor to stairwell = $5 \times 30 = 150''$

etc.

Total stair width required:

- 5th to 4th - 300 persons (100%) $\times 30''/100$ persons = 90"
- 4th to 3rd - [400 persons (100%) + 300 persons (50%)] $30''/100$ persons = 165"
- 3rd to 2nd - [500 persons (100%) + 400 persons (50%) + 300 persons (25%)] $30''/100$ persons = 232.5"
- 2nd to 1st - [200 persons (100%) + 500 persons (50%) + 400 persons (25%)] $30''/100$ persons = 165" (Use 232.5")
- 1st to exterior - [600 persons (100%) + (200 persons + 100 persons) (50%) + (500 persons + 300 persons) (25%)] $30''/100$ persons = 285"
- B₁ to 1st - [100 persons (100%) + 300 persons (50%) + 400 persons (25%)] $30''/100$ persons = 105" (Use 150")
- B₂ to B₁ - [300 persons (100%) + 400 persons (50%)] $30''/100$ persons = 150"
- B₃ to B₂ - 400 persons (100%) $\times 30''/100$ persons = 120"

Stair width required from B₁ to 1 is 150" as stair cannot decrease in width along path to exit [ILHR 51.16 (2) (c)].

A-51.151 EXIT DISTRIBUTION. The following diagrams are provided to aid building designers in determining proper exit distribution:

ARRANGEMENT OF EXITS

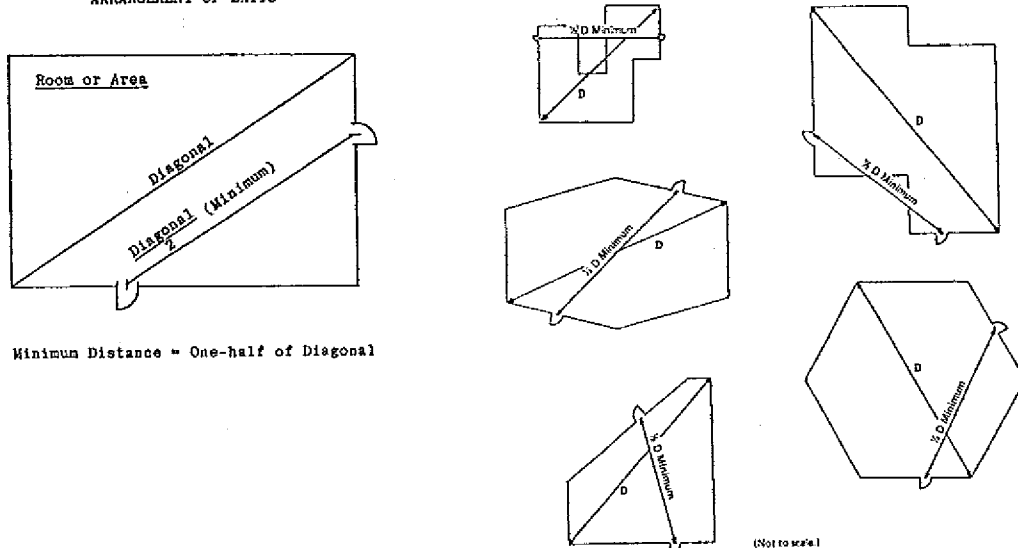

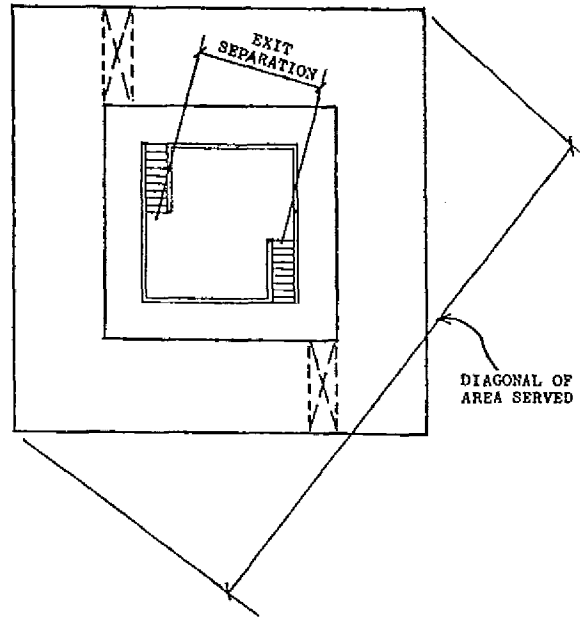
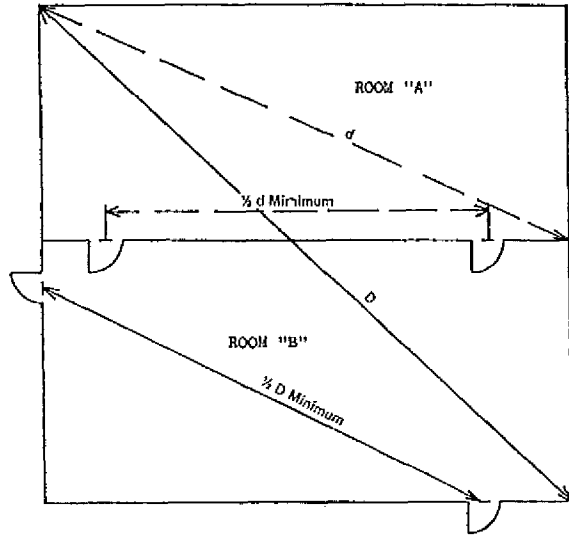

A-51.152 EGRESS CONFIGURATIONS. The following diagrams are provided to aid building designers in determining proper egress configurations:

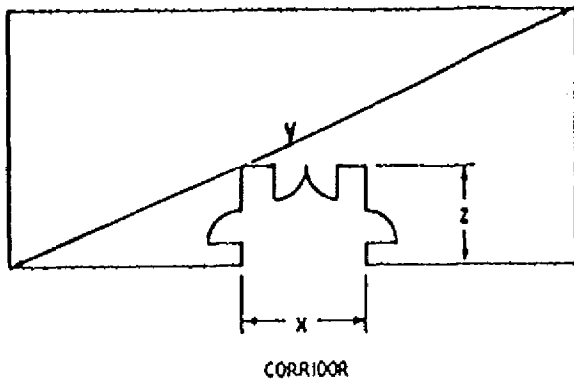

$$20' \leq x \leq \frac{y}{2}$$

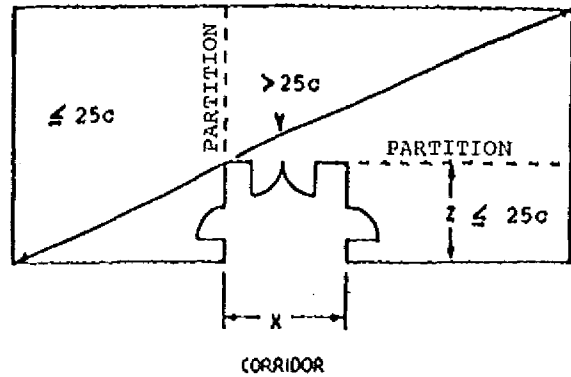

$$20' \leq x \leq \frac{y}{2}$$

A-51.22 FIRE EXTINGUISHERS. The following information is taken from the National Fire Protection Association Standard #10-1988 - Portable Fire Extinguishers. The information is provided to assist building designers in determining the number, type and location of fire extinguishers needed to comply with the provisions of the standard.

1-4 Classification and ratings of fire extinguishers.

1-4.1 Portable fire extinguishers are classified for use on certain classes of fires and rated for relative extinguishing effectiveness at a temperature of plus 70°F by testing laboratories. This is based upon the preceding classification of fires and the fire-extinguishment potentials as determined by fire tests.

1-4.2 The classification and rating system described in this standard is that used by Underwriters Laboratories, Inc., and Underwriters Laboratories of Canada and is based on extinguishing preplanned fires of determined size and description as follows:

Class A Rating — Wood and excelsior.

Class B Rating — Two-inch depth n-heptane fires in square pans.

Class C Rating — No fire test. Agent must be a non-conductor of electricity.

Class D Rating — Special tests on specific combustible metal fires.

1-5 CLASSIFICATION OF HAZARDS.

1-5.1 Light (low) hazard. Light hazard occupancies are locations where the total amount of Class A combustible materials, including furnishings, decorations and contents, is of minor quantity. This may include some buildings or rooms occupied as offices, classrooms, churches, assembly halls, etc. This classification anticipates that the majority of contents items are either noncombustible or so arranged that a fire is not likely to spread rapidly. Small amounts of Class B flammables used for duplicating machines, art departments, etc., are included provided that they are kept in closed containers and safely stored.

1-5.2 Ordinary (moderate) hazard. Ordinary hazard occupancies are locations where the total amount of Class A combustibles and Class B flammables are present in greater amounts than expected under light (low) hazard occupancies. These occupancies could consist of offices, classrooms, mercantile shops and allied storage, light manufacturing, research operations, auto showrooms,

parking garages, workshop or support service areas of light (low) hazard occupancies and warehouses containing Class I or Class II commodities as defined by NFPA 231, Standard for General Storage.

1-5.3 Extra (high) hazard. Extra hazard occupancies are locations where the total amount of Class A combustibles and Class B flammables present, in storage, production use, and/or finished product is over and above those expected and classed as ordinary (moderate) hazards. These occupancies could consist of woodworking, vehicle repair, aircraft and boat servicing, individual product display showrooms, product convention center displays, storage and manufacturing processes such as painting, dipping, coating, including flammable liquid handling. Also included is warehousing of, or in-process storage of other than Class I and Class II commodities.

3-2 FIRE EXTINGUISHER SIZE AND PLACEMENT FOR CLASS A HAZARDS.

3-2.1 Minimal sizes of fire extinguishers for the listed grades of hazards shall be provided on the basis of Table 3-2.1 except as modified by 3-2.3. Extinguishers shall be located so that the maximum travel distances shall not exceed those specified in Table 3-2.1, except as modified by 3-2.3.

3-2.1.1 Certain smaller extinguishers which are charged with multipurpose dry chemical or Halon 1211 are rated on Class B and Class C fires, but have insufficient effectiveness to earn the minimum 1-A rating even though they have value in extinguishing smaller Class A fires. They shall not be used to meet the requirements of 3-2.1.

3-2.2 Up to one-half of the complement of extinguishers as specified in Table 3-2.1 may be replaced by uniformly spaced 1½ inch hose stations for use by the occupants of the building. When hose stations are so provided they shall conform to NFPA 14, Installation of Standpipe and Hose Systems. The location of hose stations and the placement of fire extinguishers shall be in such a manner that the hose stations do not replace more than every other extinguisher.

3-2.3 Where the floor area of a building is less than that specified in Table 3-2.1, at least one extinguisher of the minimum size recommended shall be provided.

3-2.4 The protection requirements may be fulfilled with extinguishers of higher rating provided the travel distance to such larger extinguishers shall not exceed 75 feet.

WISCONSIN ADMINISTRATIVE CODE

Table 3-2.1

| | Light (Low) Hazard Occupancy | Ordinary (Moderate) Hazard Occupancy | Extra (High) Hazard Occupancy |
|---|---------------------------------------|---|--|
| Minimum rated single extinguisher | 2-A | 2-A | 4-A* |
| Maximum floor area per unit of A | 3,000 sq. ft. | 1,500 sq. ft. | 1,000 sq. ft. |
| Maximum floor area for extinguisher | 11,250 sq. ft. | 11,250 sq. ft. | 11,250 sq. ft. |
| Maximum travel dis- tance to extin- guisher | 75 ft. | 75 ft. | 75 ft. |

*Two 2 1/2 gal water type extinguishers can be used to fulfill the requirements of one 4-A rated extinguisher.

A-52.011 HAZARD CLASSIFICATIONS. The following information is provided to assist building owners and designers in determining the hazard classifications of typical building usage or occupancy:

| HAZARD CLASSIFICATION | DESCRIPTION OF FUEL LOAD | TYPICAL EXAMPLES |
|--------------------------|---|--|
| Low Hazard | Buildings or structures used for the manufacture or storage of noncombustible or low hazard materials, that do not ordinarily burn rapidly, such as but not limited to: asbestos; chalk; non-alcoholic beverages; brick and masonry; ceramic products; gypsum; glass and metals; foods in noncombustible containers; fresh fruits and vegetables in non-plastic containers; dairy products in non-wax coated paper containers; beer or wine in metal or glass containers; electrical motors and coils; and fertilizer. | Metal fabricating and assembly; foundries; water pumping and waste water treatment plants; fertilizer storage; telephone exchanges; freezer warehouses; storage in closed front metal cabinets; storage of noncombustible or low hazard materials on wood pallets or in paper cartons without significant amounts of combustible wrappings; and similar occupancies with slight combustibles. |
| Moderate Hazard | Buildings and structures used for the manufacture or storage of moderate hazard materials, which are likely to burn with moderate rapidity, but which do not produce either poisonous gases, fumes or explosives, such as but not limited to: cloth, burlap and paper bags; bamboo and rattan; canvas and leather belting; baskets; books and paper in rolls or packs; boots and shoes; cardboard and cardboard boxes; clothing; cordage; furniture; furs; glue, mucilage, paste and size; linoleum; silk; soap; sugar; tobacco products; wax candles; athletic equipment; musical instruments; beverages containing more than 12% alcohol; furniture other than metal; business machines; electronics; and plastic products not classified as high hazard. | Mercantile storage and display; offices; schoolrooms; auto showrooms; aircraft storage; light manufacturing; school shop areas; leather enameling or japanning operations; grain elevators with less than one million bushel bulk storage capacity; livestock shelters; fertilizer bagging operations; feed, flour and grist mills; lumber yards; motor vehicle repair shops; petroleum warehouses for storage of lubricating oils with a flash point of 200°F. or higher; photo engraving operations; public garages; stables; upholstery and mattress manufacturing; aircraft servicing; woodworking and millworking; bakeries; boat building operations; food processing; condensed and powdered milk manufacturing; paper mills or products; printing or publishing; refuse incinerators; and textile mills. |
| High Hazard | Buildings and structures used for the storage, manufacture or processing of: highly combustible or explosive products or materials, which are likely to burn with extreme rapidity or which may produce poisonous fumes or explosions; highly corrosive, toxic or noxious alkalis, acids or other liquids or chemicals producing flame, fumes, poisonous, irritant or corrosive gases; materials producing explosive mixtures or dusts or which result in the division of matter into fine particles subject to spontaneous ignition. | Ammunition, explosive and firework manufacture; artificial flowers and synthetic leather manufacture; celluloid and celluloid products; cotton batting and waste processes; dry cleaning establishments using or storing more than 3 gallons of flammable liquids with a flash point below 100°F. or more than 60 gallons of flammable liquids with a flash point between 100°F. and 140°F.; feather renovating; fruit ripening processes; grain elevators with one million bushel or more bulk storage capacity; hydrogenation processes; match manufacture and storage; metal enameling and japanning; nitro-cellulose film exchanges and laboratories; paint and varnish manufacture; petroleum manufacture; processing of paper or cardboard in loose form; pyroxylin product storage and manufacture; smoke houses; factories or warehouses where loose combustible fibers or dust are manufactured, processed, generated or stored; handling or using flammable liquids under conditions involving possible release of flammable vapors; and fabrication facilities and research and development areas in which hazardous production materials are used. |

A-52.04 REQUIREMENTS FOR BARRIER-FREE ENVIRONMENTS. The following illustrations are provided to give the designer visual aids for making facilities accessible.

WHEELCHAIR DIMENSIONS

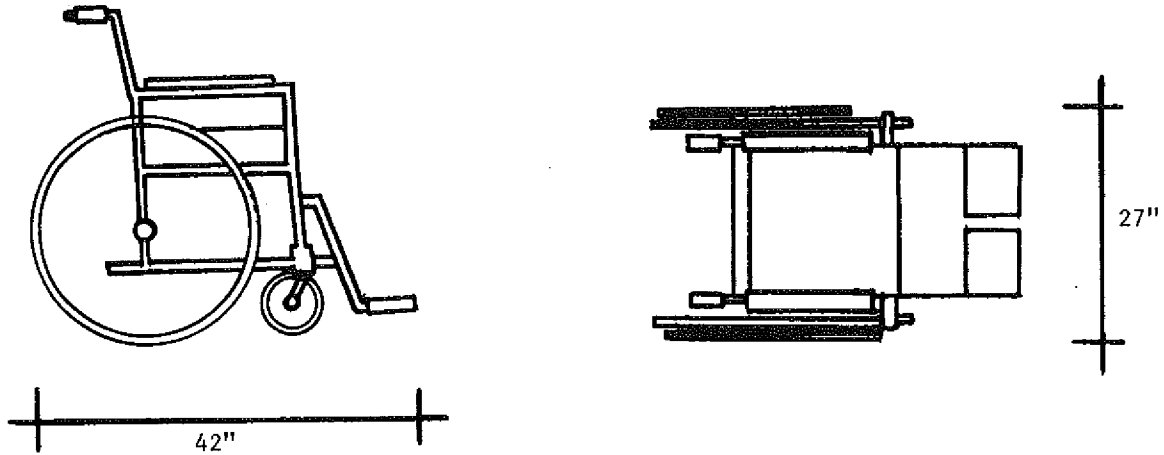

TURNING SPACE

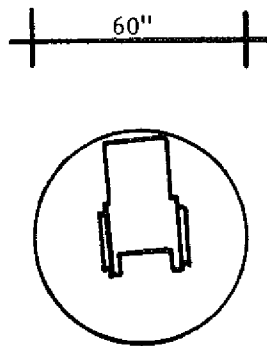

180-360° Turn

DOORS IN SERIES

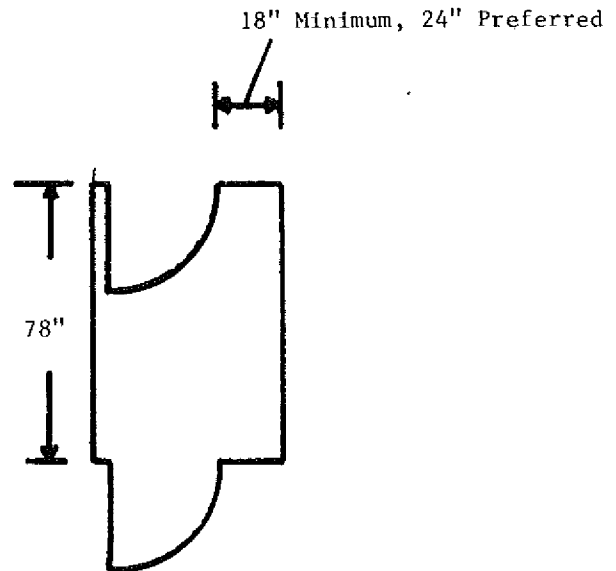

Doors in series should be hinged on the same side and should swing in the same direction. A minimum of 18 inches of clear space should be provided on the door knob side of the door. The length of the vestibule should be a minimum of 78 inches.

EXAMPLES OF ACCESSIBLE TOILET COMPARTMENTS
AS SPECIFIED IN TABLE 52.04-A

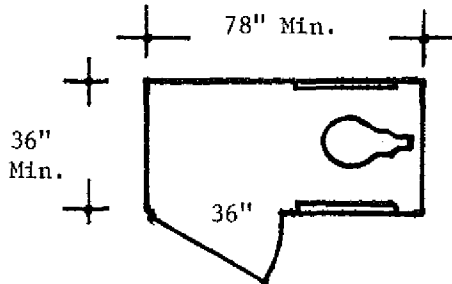

Recommended fixtures:

1. Elongated bowl;
2. Wall mounted.

Note: These are examples of toilet room compartments which are located within accessible toilet rooms.

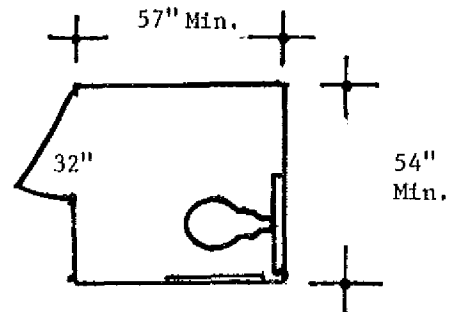
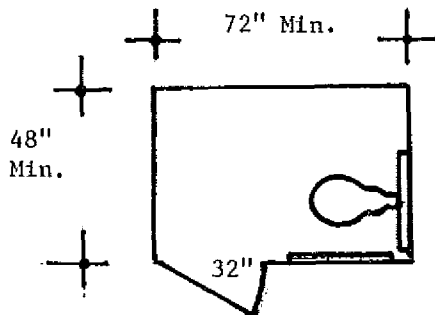
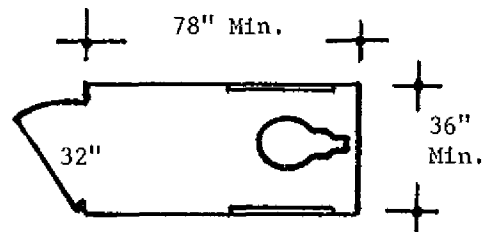
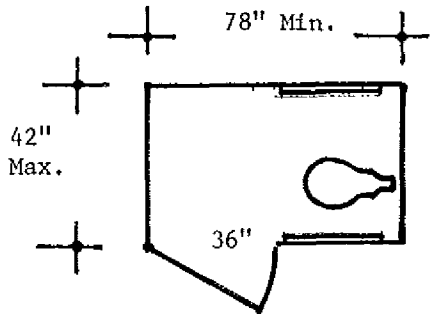

The door of the 54" x 57" water closet compartment having a frontal approach should not align with the placement of the water closet.

WISCONSIN ADMINISTRATIVE CODE

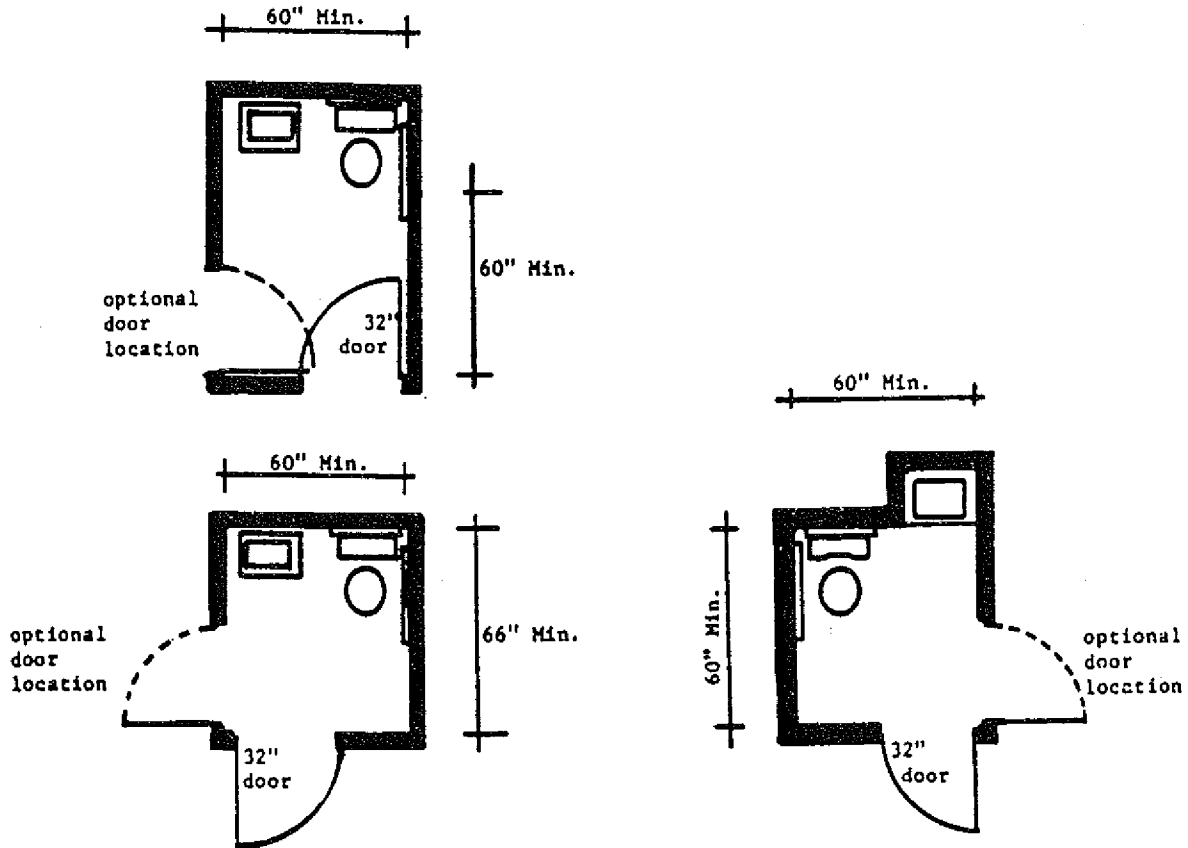
EXAMPLES OF ACCESSIBLE TOILET ROOMS
CONTAINING ONE LAVATORY AND ONE WATER CLOSET

Note #1: These examples of accessible toilet rooms may be used in health care facilities in that sufficient room for the attendant is provided.

Note #2: These examples may be modified by substituting pocket sliding doors for the swing doors shown in the examples. Surface-mounted hardware is recommended for pocket sliding doors.

A-52.04 (3) (a) *Parking spaces.* Where parking spaces are provided, accessible parking spaces, at least 12 feet wide, shall be provided and designated as specified in Table

52.04-A. Access ramps or curb ramps shall not be located in the accessible parking space or any other parking space.

Parking

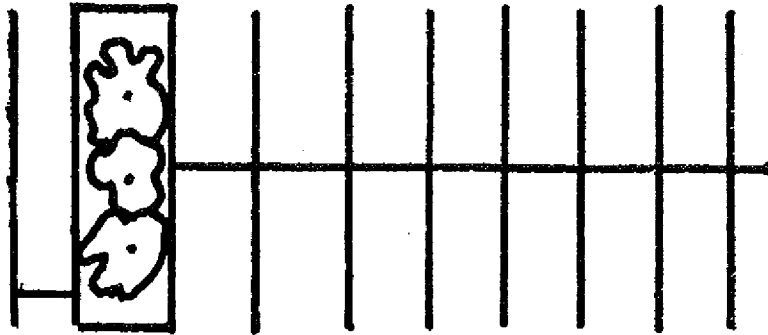

Parking for disabled

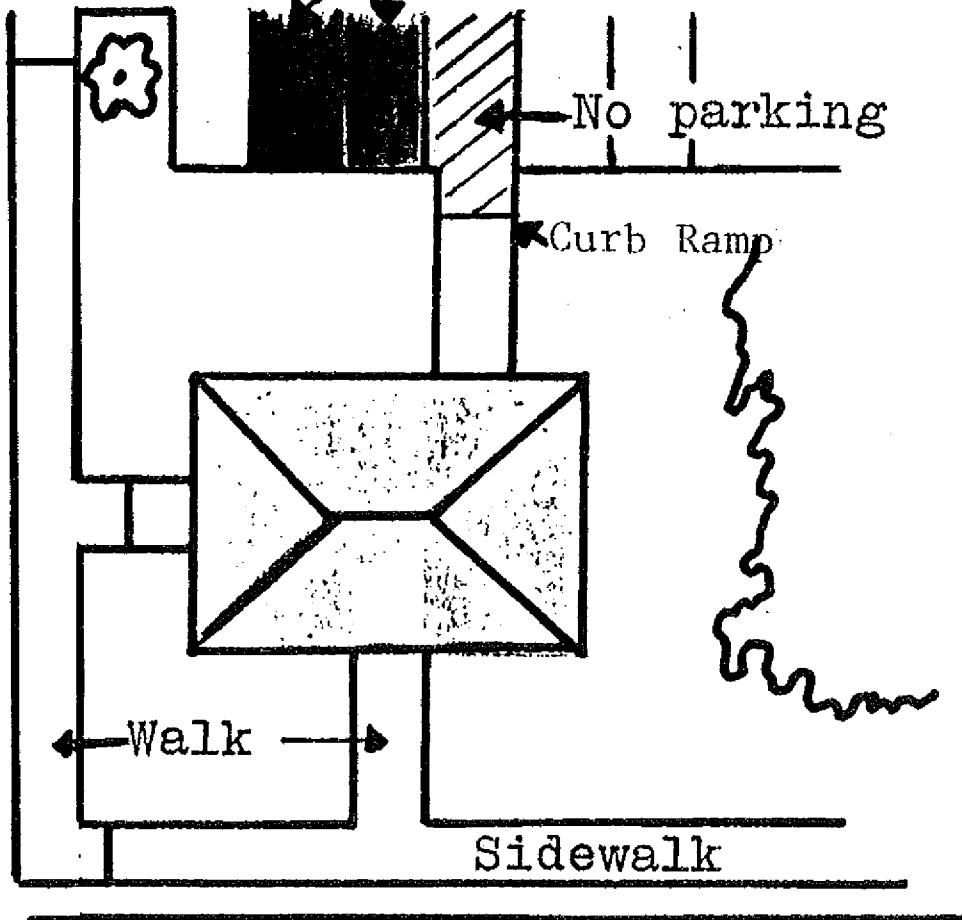

A-52.04 (3) (a) SITE REQUIREMENTS — PARKING SPACE IDENTIFICATION. The following is a reprint of Wisconsin Department of Transportation's administrative rule, s. Trans 200.07, dealing with the signage for parking spaces designated for the physically disabled:

Trans 200.07 Handicapped parking signs. (1) PURPOSE. The purpose of this section is to define and illustrate the design, size and installation requirements of the official traffic signs required under s. 346.503 (1), Stats., related to reserved parking spaces for handicapped persons.

(2) SIGN DESCRIPTION. (a) The sign shall consist of a white rectangle with longer dimension vertical, having green message, a green arrow, if required under this section, and a blue and white international symbol for the barrier-free environments. The sign may be reflective or nonreflective.

(b) The sign shall include the words "reserved parking" and the words "vehicles with VET or DIS plates or state disabled card" or other words with a similar meaning.

(c) The size of the sign shall be not less than 12 inches by 18 inches. When used on a highway with a speed limit of more than 35 miles per hour, it shall be not less than 18 inches by 24 inches.

(d) A right arrow, left arrow or the words "This Stall" or similar wording shall be included near the bottom of the sign.

(3) SIGN PLACEMENT. Each sign shall be erected on an adequate support. On highways, the vertical distance from roadway to the bottom of a sign shall be not less than 7 feet, except when overhead obstructions necessitate a lower height. In off-highway parking lots, the vertical distance from the parking lot surface, or top of curb if any, to the bottom of a sign shall be not less than 4 feet. A single sign with the message "This Space" or similar wording shall be used to designate a single reserved space. At least

2 signs are required for multiple reserved spaces. When 2 signs are used they shall be located at the outermost limits of the spaces reserved and, by arrow, designate the location of the reserved spaces.

(a) A sign shall be located at the end of an angled or right-angled space and shall be set to face a motorist entering the space.

(b) When the reserved space is parallel to the edge of a roadway, a sign shall be set at an angle of approximately 30° degrees with the line of traffic.

(4) Signs which are in place prior to the effective date of this section may remain in place and have the same effect as the signs described herein for 5 years after the effective date of this chapter provided that they include the international symbol for barrier-free environments and the wording required under (2) (b) either as part of the original sign or on a supplementary placque or placques. The requirements under (3) do not apply to these signs.

A-52.04 (3) (b) SITE REQUIREMENTS — CURB RAMPS. The following is a reprint of s. 66.616 (3) (a), Stats., dealing with the design and construction of curb ramps:

(a) Curb ramping shall be of permanent construction. The ramp shall be at least 40 inches wide. The sides of the ramp shall slope from the sidewalk or apron elevations to the ramp elevation with the widest portion of the side slope not less than 18 inches nor more than 24 inches wide at the curb. The ramp slope may not exceed one inch vertical to 12 inches horizontal from the flow line elevation of the curb. The curb opening shall be not less than 40 inches nor more than 80 inches wide at the flow line of the curb. The taper of the curb from the top of the curb to the flow line of the curb at the curb opening shall be not less than 18 inches nor more than 24 inches wide. The ramp shall be bordered on both sides and on the curb line with a 4-inch-wide yellow stripe or with brick of a contrasting color.

A-52.04 (3) (d) 3. and
(7) (c)

The handgrip portion of the handrail, if round, shall be not less than 1-1/4 in. nor more than 2 in. in diameter. If the shape of the handrail is not round, then the larger dimension shall be not more than 2 in.

If handrails are mounted adjacent to walls or other surfaces, provide a 1-1/2 in. - 2 in. clear space between the surface and the handrail. The handrail and the surfaces adjacent to the handrail shall be free of any sharp or abrasive elements.

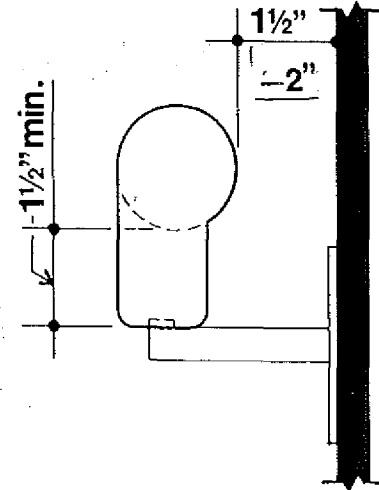

handrail

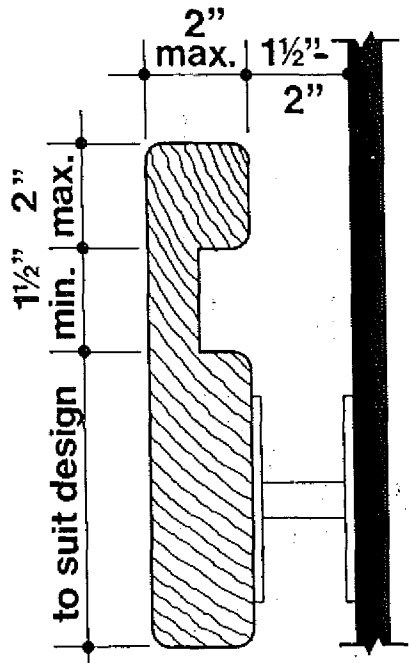

handrail

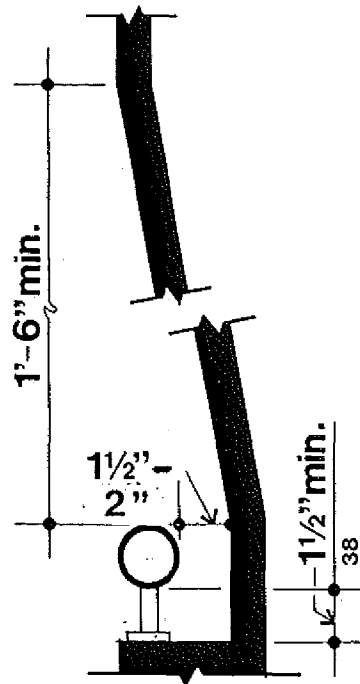

handrail

A-52.04 (4) (b) LIFTS FOR THE PHYSICALLY DISABLED. Information for lifting devices for the physically disabled and procedures for approval may be obtained from the Division of Safety and Buildings, Bureau of Technical Services, Elevator Section, P.O. Box 7969, Madison, Wisconsin 53707.

compartments shall be sized to provide ease of access, usability and uninterrupted mobility. Fixtures, doors and other obstructions shall be arranged to insure accessibility.

The space underneath lavatories can be utilized in sizing a toilet room for accessibility.

A 52.04 (8) Toilet facility details. (a) Accessible toilet rooms and compartments. Accessible toilet rooms and toilet

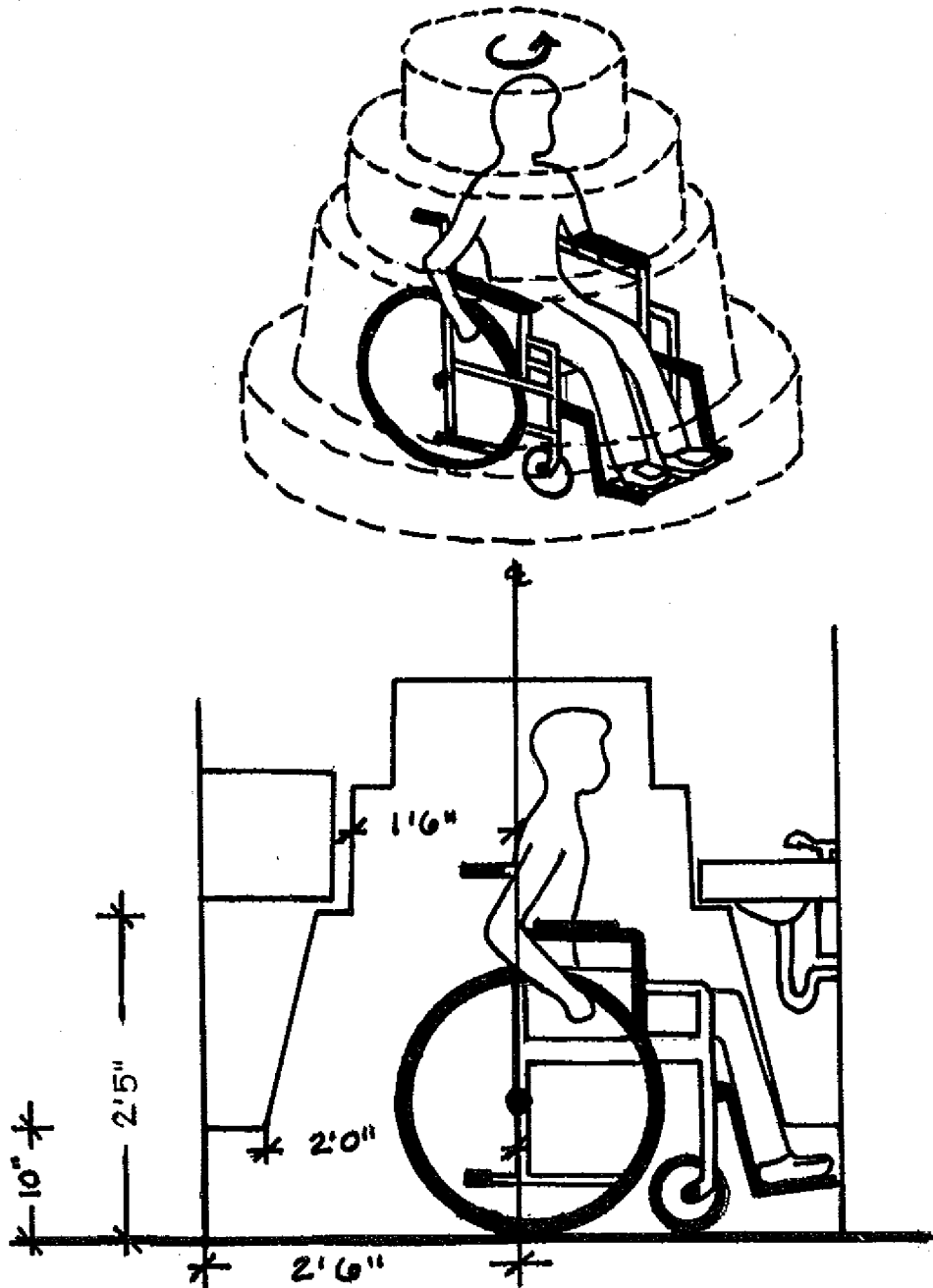

ACCESSIBLE TOILET ROOMS

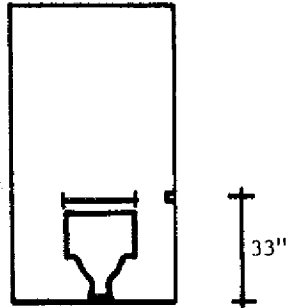

It is recommended that grab bars be from 30 to 42 inches in length and located no more than 12 inches from the back wall.

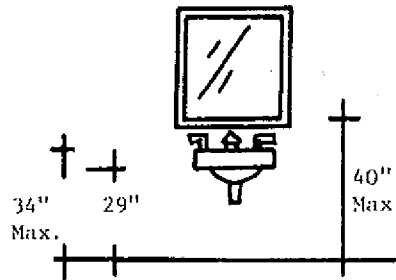
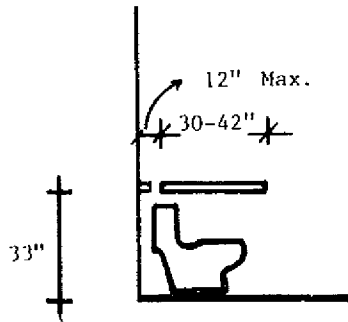

ACCESSIBLE BATHING FACILITIES

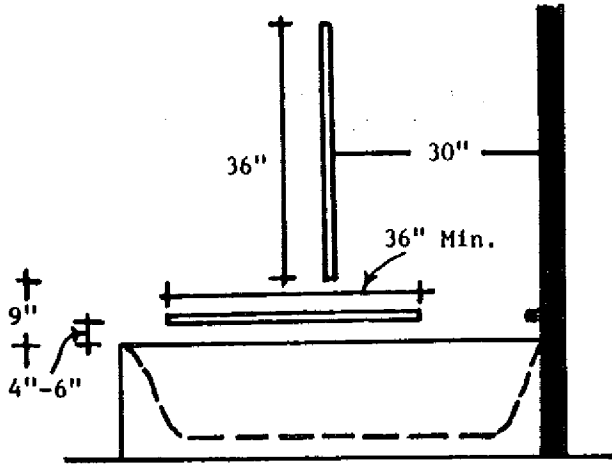

Side Elevation - Bathtub

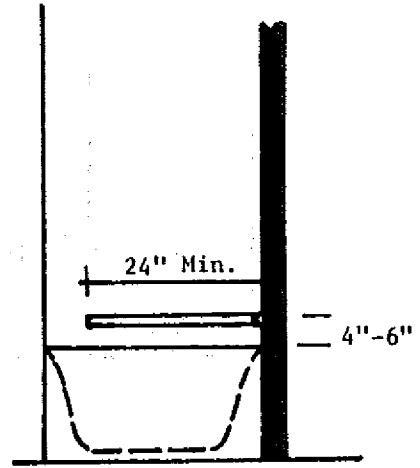

End Elevation - Bathtub

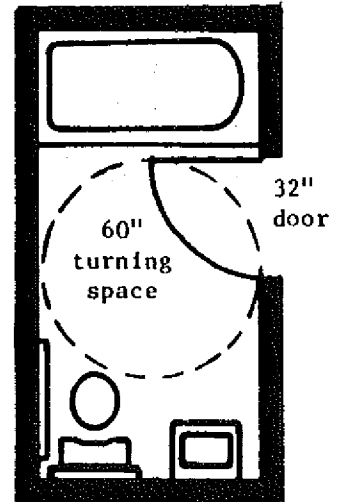
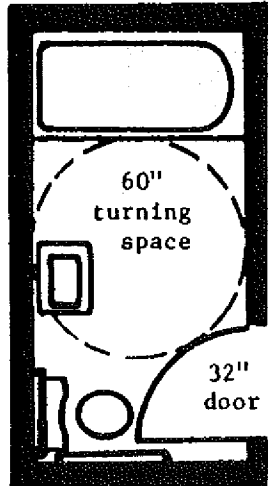

These diagrams are examples of accessible bathrooms which may be used for motels, hotels, hospitals and nursing homes.

ACCESSIBLE BATHING FACILITIES

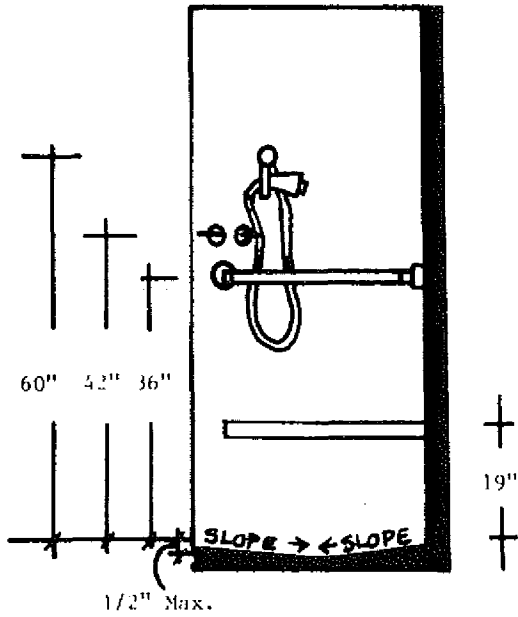

Section View - Shower

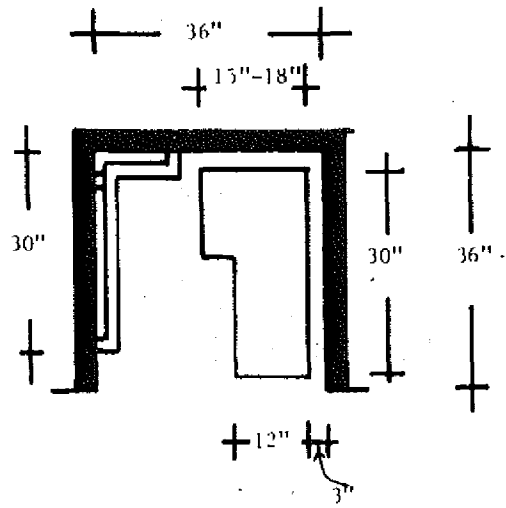

Plan View - Shower

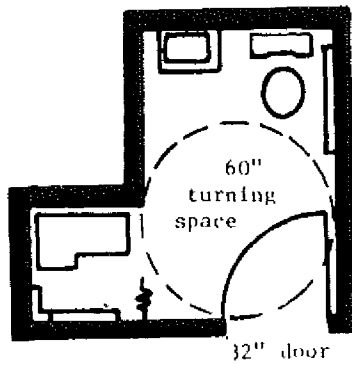

EXAMPLES OF ACCESSIBLE WATER COOLERS

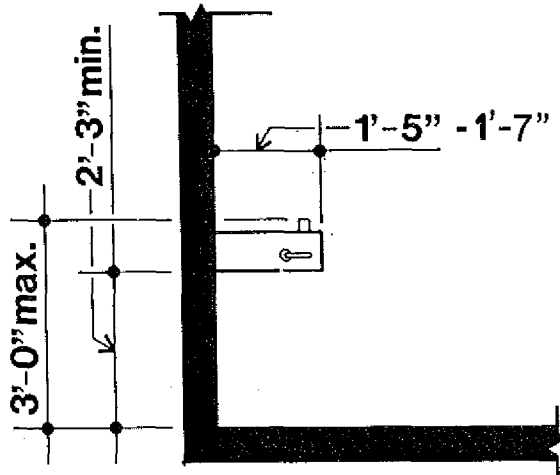

A-52.04 (11) (a) 4.a.
Wall and postmounted
cantilevered units
shall have a clear knee
space between the bottom
of the apron and the
floor or ground at
least 27 inches high,
32 inches wide, and
17 inches to 19 inches
deep.

cantilevered drinking fountain

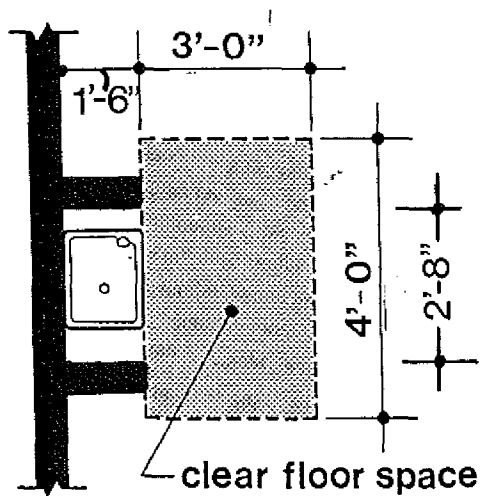

A-52.04 (11) (a) 5.
'Alcoves'. Water
fountains and water
coolers shall be located
completely within alcoves,
or positioned so as not
to encroach into pedestrian
walkways. Alcoves shall
be not less than 32 inches
in width and 18 inches
in depth.

built in drinking fountain

EXAMPLES OF ACCESSIBLE WATER COOLERS

A-52.04 (11) (a) 4.b.

Free-standing or built-in units not having a clear space under them shall have a clear floor space at least 36 inches by 48 inches that allows a person in a wheelchair to make a parallel.

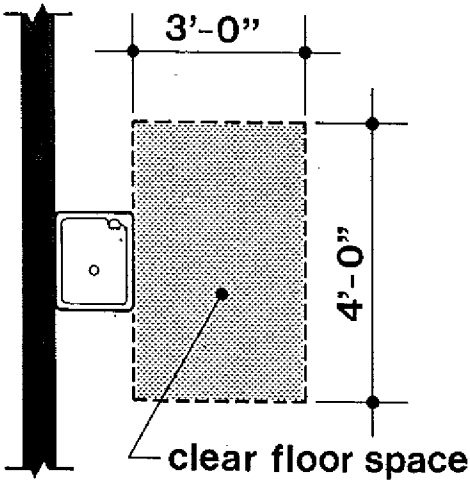

**free standing
or wall hung**
drinking fountain

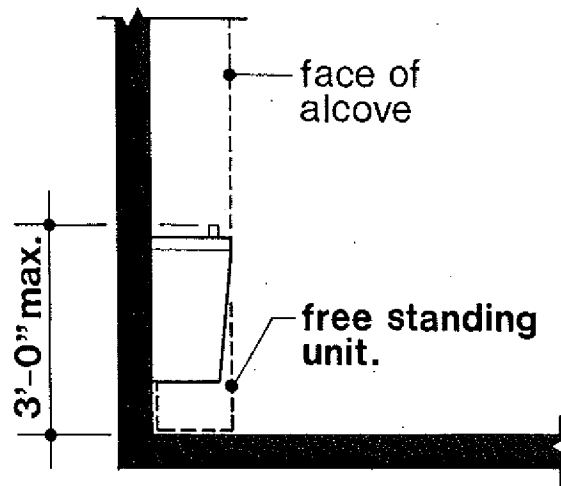

**free standing
or wall hung**
drinking fountain



INTERNATIONAL SYMBOL FOR BARRIER-FREE ENVIRONMENTS

A-52.07 (11) ACCEPTANCE OF THE ATRIUM SMOKE CONTROL SYSTEM. The following is a reprint of an approved test procedure:

Acceptance test procedure for the atrium smoke management system.

1. All testing shall be in the presence of a representative from the department.

2. All exhaust and supply-air systems shall be operationally balanced and tested. Complete air-balance reports shall be recorded on each piece of equipment, all exhaust inlets, and all supply outlets.

3. Each automatic initiating device shall be tripped to observe proper function. This test shall be performed on both normal and emergency power.

4. Each manual switch and override shall be tripped to observe proper function. This test shall be performed on both normal and emergency power.

5. All indicator lights shall display the appropriate detection and operating status.

6. Select a location on the first floor approximately 5 ft. outside the perimeter of the atrium opening. The location shall be acceptable to the department's representative.

7. Prepare three two-minute smoke bombs.

8. Ignite all three smoke bombs. When they become fully active, manually activate the atrium smoke-management system.

9. Observe and record the results.

10. After all smoke has been cleared, select an additional location on an upper level acceptable to the department's representative.

11. Prepare three more two-minute smoke bombs.

12. Ignite all three smoke bombs. When they become fully activated, again manually activate the atrium smoke-management system.

13. Observe and record the results.

14. Acceptable performance shall be movement of the smoke from the source into the atrium and out through exhaust at the top of the atrium. Smoke migration down the corridors shall be limited to no more than a light haze at a point 25 ft from the source. Furthermore, the balconies around the perimeter of the atrium shall maintain a smoke-free zone.

15. Upon the successful completion of these tests, a signed and dated copy of the department's acceptance shall be filed with the test records and a copy shall be maintained with the quarterly test log.

16. A copy of this acceptance test procedure and all plans, specifications, and calculations for the building shall be maintained with the quarterly test log.

A-52.20 Chapter ILHR 16, Wisconsin State Electrical Code, Volume 2, requires the installation of standby emergency power for certain occupancies; the following is a reprint of s. ILHR 16.46 (1):

(1) WHERE REQUIRED, Standby emergency power of a type recognized by NEC 700-12 (a), (b), (c) or (f) shall be

provided as a source of supply for required exit lights, emergency lighting or power in occupancies where people are housed, assembled or confined with a capacity or area equal to or greater than those listed in Column B of Table 16.46.

TABLE 16.46
OCCUPANCIES REQUIRING STANDBY EMERGENCY POWER

| Column A Occupancy | Column B Calculated Capacity or Area |
|--|--|
| 1. Apartment buildings | 50 bedrooms, including efficiency units |
| 2. Arenas | 800 square feet (Use seated space only) |
| 3. Art galleries | 20,000 square feet |
| 4. Assembly halls such as church dining rooms and fellowship halls, dance halls, banquet halls, dining rooms, restaurants, taverns, night clubs, school and day care center multi-purpose rooms, and similar occupancies | 2,000 square feet |
| 5. Assembly halls with stage | 1,400 square feet |
| 6. Auditoriums | 1,400 square feet |
| 7. Banks | 30,000 square feet |
| 8. Bowling alleys | 200 persons based on 5 persons per alley plus number of spectator seats and 10 square feet per person for bar and dining areas |
| 9. Centers for developmentally disabled | 20 inmate beds |
| 10. Children's homes | 20 beds |
| 11. Community-based residential facilities | 20 beds |
| 12. Convents | 200 beds |
| 13. Dormitories, including those used in detention schools | 200 beds |
| 14. Exhibition buildings | 12,000 square feet |
| 15. Factories | 30,000 square feet |
| 16. Field houses | 800 square feet (Use seated space only) |
| 17. Gymnasiums | 200 persons based on 6 square feet per person for seated space and 15 square feet per person for unseated space |
| 18. Hospitals | 20 patient beds |
| 19. Hotels | 200 rooms |
| 20. Jails | 20 inmate beds |
| 21. Lecture halls | 1,400 square feet |
| 22. Libraries | 200 persons based on 20 square feet per person for reading rooms and 100 square feet per person for balance |
| 23. Lodge halls | 200 persons based on 6 square feet per person for seated space and 15 square feet per person for unseated space |
| 24. Motels | 100 rooms |
| 25. Museums | 20,000 square feet |
| 26. Nursing homes | 20 patient beds |
| 27. Office buildings | 30,000 square feet |
| 28. Rooming houses | 200 rooms |
| 29. Skating rinks | 3,000 square feet |
| 30. Stores | 200 persons based on 30 square feet per person for first floor and 60 square feet per person for second floor and above |
| 31. Swimming pools (indoor) | 450 square feet |
| 32. Theaters and theater lobbies | 1,400 square feet (Theater and lobby must be combined in determining total area) |
| 33. Warehouses | 120,000 square feet |

A-52.60 (1) Water closets. The following is a reprint of s. ILHR 84.20 (5) (m) 7. from the plumbing code:

7. A water closet may not be located closer than 15 inches from its center to any side wall, partition, vanity, or other obstruction, nor closer than 30 inches center to center, between water closets. There shall be at least 24

inches clearance in front of a water closet to any wall, fixture or door.

A-53.11 (4) (c) Increase in roof loads. The following design provisions may be used to determine the increase in roof loads as required by this section.

ROOF SHAPES

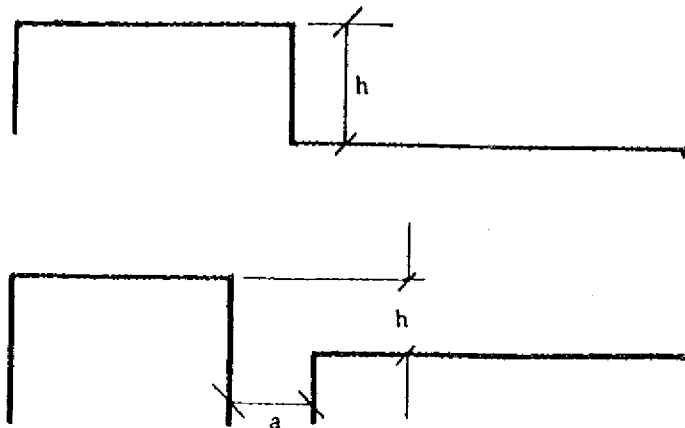

Lower level of multi-level roofs (when upper roof is part of the same building or on an adjacent building not more than 15 feet away).

SNOW LOAD DISTRIBUTIONS AND COEFFICIENTS, LIMITATIONS

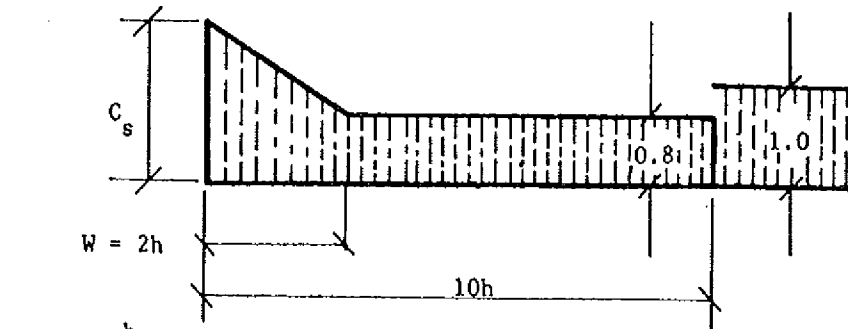

$$C_s = 15 \frac{h}{g}$$

when $15 \frac{h}{g} < 1.0$ use $C_s = 1.0$

when $15 \frac{h}{g} > 3.0$ use $C_s = 3.0^*$

$$W = 2h$$

when $h < 5$ ft use $W = 10$
 when $h > 15$ ft use $W = 30$

h = difference of roof heights in ft.

g = roof live load in psf [ILHR 53.11 (4)]

w = width of drift from higher building in ft.

a = distance between buildings < 15 ft.

Design upper roof for loads applicable to single-level roofs.

*An upper limit of 3 times the basic roof load has been suggested. It should be noted, however, that higher loads have been observed where an upper roof was very long (measured perpendicularly to the step between the upper and lower roofs). On the other hand, for relatively short upper roofs (say less than 50 ft), a reduction below the calculated C_s value may be judged adequate by the designer.

[11]

ROOF SHAPES

Valley areas of two-span and multi-span sloped or curved roofs

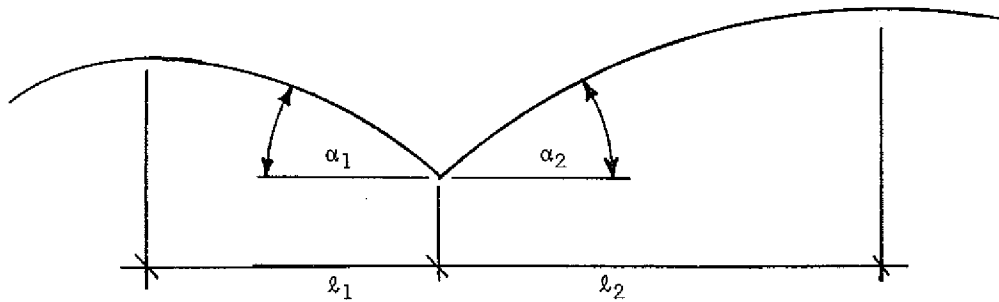
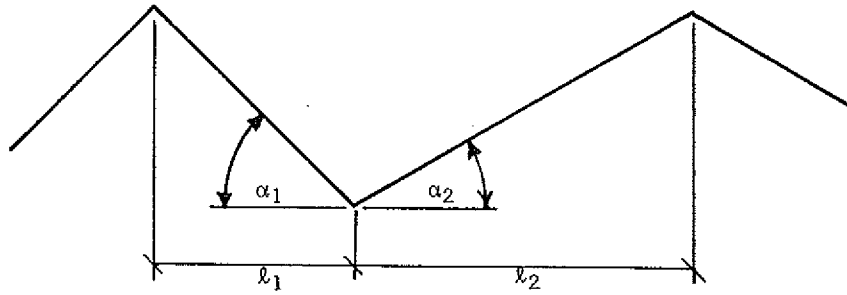

SNOW LOAD DISTRIBUTIONS AND COEFFICIENTS, LIMITATIONS

CASE I



CASE II

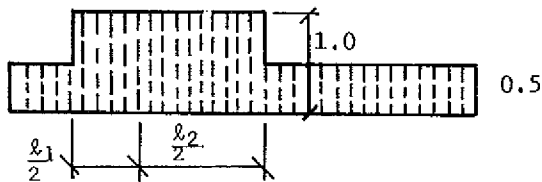

CASE III

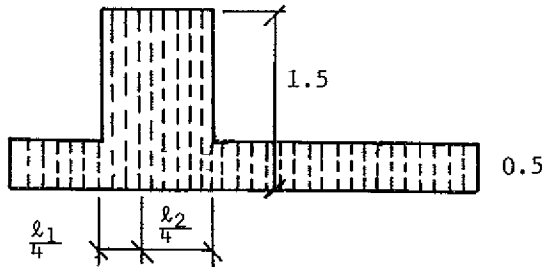

For both α_1 and $\alpha_2 \leq 10^\circ$ use Case I only; otherwise use Case I, II and III

ROOF SHAPES

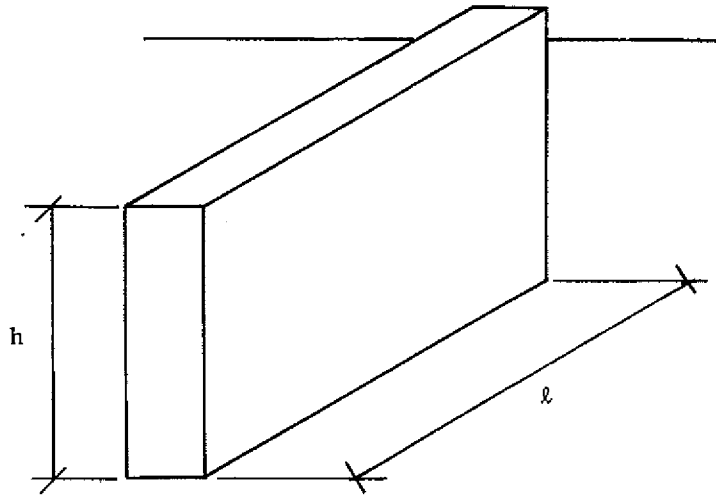

Roof areas adjacent to projections and obstructions on roofs

SNOW LOAD DISTRIBUTIONS AND COEFFICIENTS, LIMITATIONS

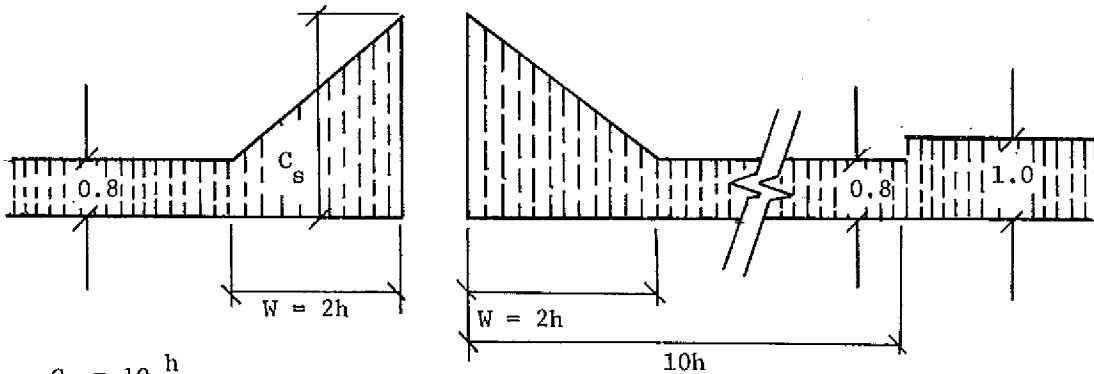

$$C_s = 10 \frac{h}{g}$$

when $10 \frac{h}{g} < 1.0$ use $C_s = 1.0$

when $10 \frac{h}{g} > 2.0$ use $C_s = 2.0$

when $l < \frac{g}{6}$ use $C_s = 1.0$

$$W = 2 h$$

when $h < 5$ ft use $W = 10$

when $h > 15$ ft use $W = 30$

h = height of projection in ft.

g = roof live load in psf

w = width of snow drift in ft.

l = length of projection in ft.

ROOF SHAPES

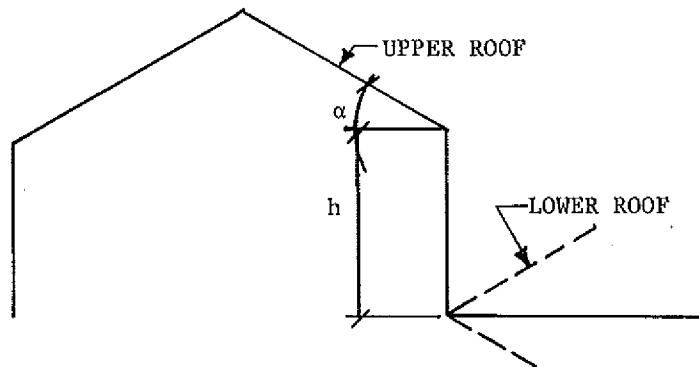

Lower of multi-level roofs with upper roof sloped towards lower roof, where α exceeds 10° .

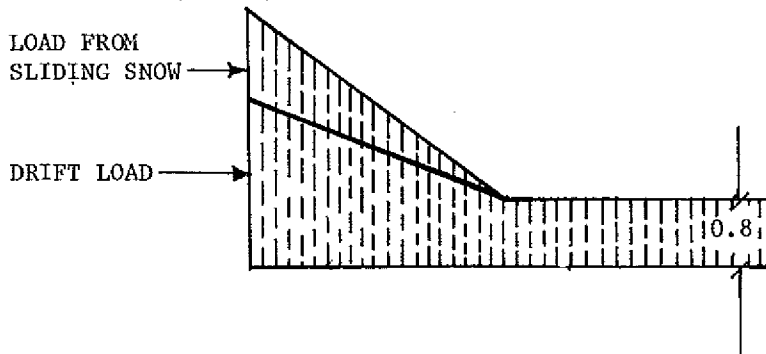
SNOW LOAD DISTRIBUTIONS AND COEFFICIENTS, LIMITATIONS

Design lower roof for loads applicable to multi-level roof plus a portion of the sliding snow from the upper roof.*

Design upper roof for loads applicable to single-level roofs.

*Where snow is likely to slide onto a lower roof from an upper roof, the lower roof should be designed for the load as provided for multi-level roofs plus an additional load produced by the snow that may slide from the upper roof. It is not possible to provide coefficients for this situation, but the following guide is recommended. Because of the remote probability that both upper and lower roofs will have their full load over the full areas simultaneously when sliding occurs, it may be assumed that the lower roof would be carrying its full load and that sliding of 50% of the total weight of the applicable uniformly distributed snow load from the upper roof would occur.

A-53.11 (4) (d) ROOF DESIGNED FOR CONTROL FLOW DRAINAGE. This section refers to the requirements of the Plumbing Code (ch. ILHR 82) for storm drain sizes where control flow drainage roof design is used. The following information from the plumbing code is provided for use by the building designer:

Partial Reprint of s. ILHR 82.36 (4) and (5)

(4) LOAD ON DRAIN PIPING. (a) *Storm water drainage.* The load factor on storm water drain piping shall be computed in terms of gallons per minute or on the square footage of the horizontal projection of roofs, paved areas, yards and other tributary areas.

(b) *Continuous flow devices.* Where there is a continuous or semicontinuous discharge into the storm building drain or storm building sewer, as from a pump, air conditioning unit, or similar device, each gallon per minute of such discharge shall be computed as being equivalent to 26 square feet of roof area.

(5) SELECTING SIZE OF STORM AND CLEAR WATER DRAIN PIPING. (a) *Horizontal storm water drain piping.* The pipe size for horizontal drain piping for storm water shall be determined from Tables 82.36-1 to 82.36-4.

Table 82.36-1

MINIMUM SIZE OF STORM WATER HORIZONTAL DRAIN PIPING SERVING ROOF AREAS

| Pipe Diameters (in inches) | Maximum Roof Areas (in square feet) | | | |
|----------------------------|-------------------------------------|----------|----------|----------|
| | Pitch of Piping Per Foot | | | |
| | 1/16 inch | 1/8 inch | 1/4 inch | 1/2 inch |
| 3 | 650 | 910 | 1,300 | 1,820 |
| 4 | 1,300 | 1,950 | 2,990 | 3,770 |
| 5 | 2,470 | 3,640 | 5,070 | 7,020 |
| 6 | 4,160 | 5,980 | 8,320 | 11,700 |
| 8 | 9,320 | 13,000 | 18,200 | 26,000 |
| 10 | 17,680 | 24,700 | 33,800 | 50,440 |
| 12 | 27,300 | 41,080 | 57,200 | 81,900 |
| 15 | 52,000 | 72,800 | 105,300 | 146,640 |
| 18 | 85,800 | 121,550 | 174,200 | 247,000 |
| 21 | 156,520 | 179,660 | 256,880 | 374,400 |
| 24 | 187,200 | 261,560 | 382,200 | 546,000 |

Note: Divide square footage by 26 to obtain flow in gpm.

Table 82.36-4
MAXIMUM CAPACITY OF STORM WATER HORIZONTAL DRAIN PIPING FLOWING FULL

| Pipe Diameters (in inches) | Maximum Capacities in Gallons Per Minute | | | |
|----------------------------|--|----------|----------|----------|
| | Pitch of Piping Per Foot | | | |
| | 1/16 inch | 1/8 inch | 1/4 inch | 1/2 inch |
| 3 | 25 | 35 | 50 | 70 |
| 4 | 50 | 75 | 115 | 145 |
| 5 | 97 | 140 | 195 | 270 |
| 6 | 160 | 230 | 320 | 450 |
| 8 | 355 | 500 | 700 | 1,000 |
| 10 | 680 | 950 | 1,300 | 1,940 |
| 12 | 1,050 | 1,580 | 2,200 | 3,150 |
| 15 | 2,000 | 2,800 | 4,050 | 5,640 |
| 18 | 3,300 | 4,675 | 6,700 | 9,500 |
| 21 | 6,020 | 6,910 | 9,880 | 14,400 |
| 24 | 7,200 | 10,060 | 14,700 | 21,000 |

(b) *Vertical conductors for storm water.* 1. A vertical conductor for storm water shall not be smaller than the largest horizontal branch connected thereto.

2. Vertical conductors shall be sized in accordance with Table 82.36-5 or the diameter D, where

$$D = 1.128 \sqrt{\frac{A}{X}}$$

Where, A = the area of the roof in square feet

X = 300 square feet per square inch for a roof covered with gravel or slag and with a pitch not exceeding 1/4 inch per foot; or

= 250 square feet per square inch for a roof covered with gravel or slag and with a pitch of greater than 1/4 inch per foot; or

= 200 square feet per square inch for a roof with a metal, tile, brick or slate covering and of any pitch.

Table 82.36-5

MINIMUM DIAMETER OF VERTICAL CONDUCTORS

| Type of Roof | Maximum Roof Areas (in square feet) | | | | | |
|--|-------------------------------------|-------|-------|-------|-------|--------|
| | Pipe Diameters (in inches) | | | | | |
| | 2½ | 3 | 4 | 5 | 6 | 8 |
| Roofs covered with gravel, slag, or similar material and with a pitch of ¼" per foot or less. | 1,645 | 2,120 | 3,780 | 5,885 | 8,490 | 15,125 |
| Roofs covered with gravel, slag or similar material and with a pitch greater than ¼" per foot. | 1,220 | 1,770 | 3,150 | 4,905 | 7,075 | 12,600 |
| Roofs covered with metal, tile, brick, slate or similar material and of any pitch. | 975 | 1,415 | 2,520 | 3,925 | 5,660 | 10,080 |

Note: Divide square footage by 26 to obtain flow in gpm.

A-53.15 LOAD COMBINATIONS. It is the intent of this section that the loads specified in ss. ILHR 53.10 through 53.14 be considered to act in the following combinations, whichever is critical, for the design of the building frame, foundation or structural member:

1. Dead load plus live load.
2. Dead load plus wind load.
3. Dead load plus live load plus wind load.
4. Dead load plus live load plus crane loads.

Distribution of live loads which would cause the maximum shear, bending moment or stress in structural members should be investigated.

A-54.02 (4) EXIT DISTANCE. The following illustrations and text are provided to explain the procedure and intent of using the triangulation method of exit distance determination.

Exit travel must terminate at one of the following types of exits:

1. Standard exit to grade (ILHR 51.15)
2. Enclosed stairways (ILHR 51.17 and 51.18)
3. Horizontal exits (ILHR 51.19)
4. Fire escapes (ILHR 51.20)

Therefore, exit distance must be measured from one of these exit types. All exits must lead to a street, alley or open court which is connected to a street or alley.

Register, January, 1994, No. 457

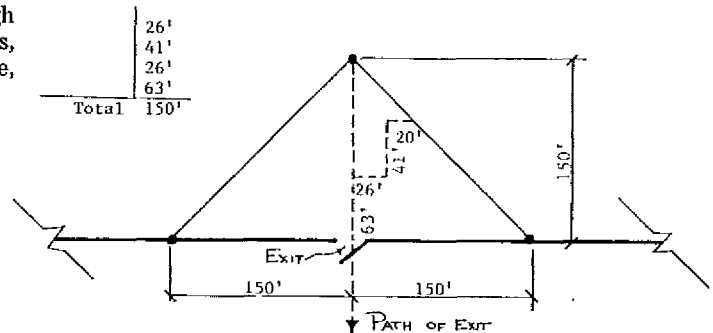

Procedure:

1. Beginning at designated exit type, measure required exit distance (150 feet, for example) at right angles to and parallel with (on both sides) the exit.
2. Connect end points to form the "exit triangle".
3. All areas within the triangle are within the required exit distance when traveling toward or at right angles to the exit.
4. All the interior space of a building must fall within the "exit triangles" formed by using the required exits for the building.
5. When measuring exit distance in stairways, only the horizontal travel distance is included in the determination.

A-54.02 (4) (c) The use of the term "high hazard" as referred to in this section is intended to apply to the following list of operations and occupancies:

1. Aircraft hangars.
2. Dry cleaning establishments: using gasoline or other volatile flammable liquids.
3. Enameling or japanning.

4. Mills: sugar, starch cereal, feed, flour and grist mills.
5. Paint and varnish: manufacturing, storing, handling, spraying, and other related operations.
6. Proxylin products: manufacture and storage.
7. Repair garages.
8. Smoke houses.
9. Storage of: explosive gases under pressure (15 psi and over 2500 cubic feet) such as acetylene, hydrogen, natural gas, etc.
10. Storage of: materials with a flash point under 200° F. such as celluloid products, kerosene, oils, etc.
11. Woodworking establishments.

A-57.02 (2) (b) VERTICAL DIVISION WALLS. See drawings and illustrations in s. A 51.03 (5) (a) for typical floor/ceiling-wall connection details for vertical division walls. Disregard masonry components shown in drawings when masonry is not used in the construction of the vertical division wall.

A-57.07 (3) CHANGES OF ELEVATION WITHIN INDIVIDUAL LIVING UNITS. Section ILHR 57.07 (3) permits the steps, stairs and ramps within individual living units to conform with s. ILHR 21.04 of the Uniform Dwelling Code. The following is a reprint of the applicable portions of that section:

ILHR 21.04 Stairs. Every exterior or interior stairs, except those leading to attics or crawl space or similar non-habitable spaces, shall conform to the requirements of this section.

(1) LANDINGS. (a) *Intermediate landings.* Intermediate landings located in a flight of stairs shall be at least as wide as the stairs and shall measure at least 3 feet in the direction of travel. Trim and handrails may project no more than 3½ inches into the required width.

(b) *Landings at the top and base of stairs.* A level landing shall be provided at the top and at the foot of every stairs. The landing shall be at least as wide as the stairs and shall measure at least 3 feet in the direction of travel.

(c) *Doors at landings.* Except as provided in subds. 1 to 4, level landings shall be provided on each side of any door located at the foot or head of a stairway, regardless of the door swing. In the application of the exceptions given in subds. 1 to 4, stairways to attached garages or porches are considered to be interior stairways.

1. Exception. A landing shall not be required between the door and the head of interior stairs, provided the door does not swing over the stairs.

2. Exception. A landing shall not be required between the door and the head of an interior stairway of 2 or fewer risers, regardless of doorswing.

3. Exception. A landing shall not be required between a sliding glass door and the head of an exterior stairway of 3 or fewer risers.

4. Exception. The exterior landing, platform or sidewalk at an exterior doorway shall be located not more than 8 inches below the interior floor elevation. The landing plat-

form shall have a length at least equal to the width of the door.

(2) HANDRAILS AND GUARDRAILS. (a) *Handrails.* Every stairs of more than 3 risers shall be provided with at least one handrail. Handrails shall be provided on all open sides of stairways.

(b) *Guardrails.* All openings between floors, open sides of landings, platforms, balconies or porches which are more than 24 inches above grade or a floor, shall be protected with guardrails.

(c) *Handrail and guardrail details.* 1. Height. Handrails shall be located at least 30 inches, but not more than 34 inches, above the nosing of the treads. Guardrails shall be located at least 36 inches above the upper surface of the floor.

2. Open railings. Open guardrails or handrails shall be provided with intermediate rails or an ornamental pattern to prevent the passage of a sphere with a diameter larger than 9 inches.

3. Clearance. The clearance between the handrail and the wall surface shall be at least 1½ inches.

4. Loading. Handrails and guardrails shall be designed and constructed to withstand a 200 pound load applied in any direction.

5. Exterior rails. Exterior handrails and guardrails shall be constructed of metal, decay resistant or pressure treated wood or shall be protected from the weather.

(3) STAIR DETAILS. Stairs shall meet the following requirements:

(a) *Minimum width.* Every stairs shall measure at least 3 feet in width.

(b) *Headroom.* Every stairs shall be provided with a minimum headroom clearance of 6 feet 4 inches. The minimum clearance shall be measured vertically from a line parallel to the nosing of the treads to the ceiling or soffit directly above that line.

(c) *Treads and risers.* Risers shall not exceed 8 inches in height, measured vertically from tread to tread. Treads shall be at least 9 inches wide, measured horizontally from nosing to nosing. There shall be no variation in uniformity exceeding 3/16 inch in the width of tread or in the height of risers. No flight of stairs shall exceed 12 feet in height unless landings are provided.

(d) *Winders.* Winder steps may be used in stairs where the length of the tread is at least 3 feet and the winder tread measures at least 7 inches in width from nosing to nosing at a point one foot from the narrow end of the tread.

(e) *Spiral stairs.* Spiral stairs may be used as an exit stairs. The tread shall measure at least 26 inches from the outer edge of the supporting column to the inner edge of the handrail and at least 7 inches in width from nosing to nosing at a point one foot from the narrow end of the tread.

A-57.11 The intent of this section is to apply to floor levels not more than one story below grade (at building).

A-57.11 (1) (f) It is the intent of this subsection that each living unit needs only one means of exit from within the unit and that the entire building be provided with no less than 2 exits.

A-59.14 (2) (c) EXIT DISTANCE. See the information and illustration contained in A-54.02 (4).

A-60.19 (4) The standard is available from the National Fire Protection Association, Batterymarch Park, Quincy, Massachusetts 02269.

A-60.35 Class A fires are fires in ordinary combustible materials such as wood, cloth, paper, rubber, and many

plastics. Class B fires are fires in flammable liquids, gases and greases.

A-60.36 (1) (a) See A-60.19 (4).

A-62.25 (1) CLEARANCE LIMITATIONS. The intent is to require the minimum 7 feet 0 inches clearance only in traffic lanes and in all areas normally used by the public to leave from and return to their vehicles.

A-62.50 FIRE EXTINGUISHERS. See A-51.22 for related information.

A-64.20. EQUIPMENT RATINGS AND SAFETY CONTROLS. Standards for the testing and installation of heating and ventilating equipment:
The department recognizes the following reference stan-

- (1) American National Standards Institute, Inc., 1430 Broadway, New York, N.Y. 10018:
 - (a) GAS-FIRED ROOM HEATERS, Vol. 1, ANSI Z21.11.1;
 - (b) GAS-FIRED LOW PRESSURE STEAM AND HOT WATER BOILERS, ANSI Z21.13;
 - (c) GAS UNIT HEATERS, ANSI Z21.16;
 - (d) DOMESTIC GAS CONVERSION BURNERS, ANSI Z21.17;
 - (e) GAS APPLIANCE PRESSURE REGULATORS, ANSI Z21.18;
 - (f) AUTOMATIC GAS IGNITION SYSTEMS AND COMPONENTS, ANSI Z21.20;
 - (g) AUTOMATIC GAS VALVES, ANSI Z21.21;
 - (h) RELIEF VALVES AND AUTOMATIC GAS SHUTOFF DEVICES FOR HOT WATER SYSTEMS, ANSI Z21.22;
 - (i) GAS APPLIANCE THERMOSTATS, ANSI Z21.23;
 - (j) GAS-FIRED DUCT FURNACES, ANSI Z21.34;
 - (k) GAS FILTERS ON APPLIANCES, ANSI Z21.35;
 - (l) GAS-FIRED GRAVITY AND FAN TYPE DIRECT VENT WALL FURNACES, ANSI Z21.44;
 - (m) GAS-FIRED GRAVITY AND FORCED AIR CENTRAL FURNACES, ANSI Z21.47;
 - (n) GAS-FIRED GRAVITY AND FAN TYPE FLOOR FURNACES, ANSI Z21.48;
 - (o) GAS-FIRED GRAVITY AND FAN TYPE VENTED WALL FURNACES, ANSI Z21.49;
 - (p) VENTED DECORATIVE GAS APPLIANCES, ANSI Z21.50;
 - (q) GAS-FIRED SINGLE FIREBOX BOILERS, ANSI Z21.52;
 - (r) GAS-FIRED HIGH PRESSURE STEAM AND HOT WATER BOILERS (Inputs not over 400,000 Btu/hour), ANSI Z21.59;
 - (s) DECORATIVE GAS APPLIANCES FOR INSTALLATION IN VENTED FIREPLACES, ANSI Z21.60;
 - (t) DIRECT GAS-FIRED MAKE-UP AIR HEATERS, ANSI Z83.4;
 - (u) GAS-FIRED HEAVY DUTY FORCED AIR HEATERS, ANSI Z83.5; and
 - (v) GAS-FIRED INFRARED HEATERS, ANSI Z83.6.
- (2) Canadian Standards Association, Certification Division, Rexdale, Ontario Canada, M9W 1R3;
 - (a) Solid-Fuel Fired Appliances for Residential Use, CSAB 366M.
- (3) Energy Testing Laboratory of Maine, South Maine Vocational Technical Institute, South Portland, Maine 04106.
 - (a) Testing for Safety — Requirements and Test Procedures for Solid-Fuel Burning Central Heating Appliances and Combination Oil- and Solid-Fuel Burning Central Heating Appliances, ETLM Standard #78-1.
- (4) International Conference of Building Officials, Inc., 5360 South Workman Mill Road, Whittier, California 90601:
 - (a) Research Committee Acceptance Criteria for Fireplace Heat Exchangers.
- (5) Underwriters' Laboratories, Inc., 333 Pfingsten Road, Northbrook, Illinois 60062:
 - (a) CHIMNEYS, FACTORY-BUILT, RESIDENTIAL TYPE AND BUILDING HEATING APPLIANCES, UL 103;
 - (b) FACTORY BUILT FIREPLACES, UL 127;
 - (c) OIL BURNERS, UL 296;
 - (d) CONTROLS, PRIMARY SAFETY FOR GAS- AND OIL-FIRED APPLIANCES, UL 372;
 - (e) SOLID-FUEL FIRED CENTRAL FURNACES, UL 391;
 - (f) GAS VENTS, UL 441;
 - (g) HEATING APPLIANCES, ELECTRIC, UL 499;
 - (h) HEAT PUMPS, UL 559;
 - (i) TYPE I LOW-TEMPERATURE VENTING SYSTEMS, UL 641;
 - (j) OIL-FIRED BOILER ASSEMBLIES, UL 726;
 - (k) OIL-FIRED CENTRAL FURNACES, UL 727;
 - (l) OIL-FIRED FLOOR FURNACES, UL 729;
 - (m) OIL-FIRED WALL FURNACES, UL 730;
 - (n) OIL-FIRED UNIT HEATERS, UL 731;
 - (o) HEATERS, AIR AND DIRECT-FIRED HEATERS, OIL-FIRED, UL 733;
 - (p) FIREPLACE STOVES, UL 737;
 - (q) COMMERCIAL-INDUSTRIAL GAS HEATING EQUIPMENT (Inputs over 400,000 Btu/hour), UL 795;
 - (r) HEATERS, ELECTRIC, FOR USE IN HAZARDOUS LOCATIONS; Class I, Groups A, B, C and D, and Class II, Groups E, F and G, UL 823;
 - (s) ELECTRIC BOILERS, UL 834;
 - (t) HEATERS, ELECTRIC DRY BATH, UL 875;
 - (u) FAN COIL UNITS AND ROOM FAN HEATER UNITS, UL 883;

ILHR 50-64 Appendix A

- (v) OIL-BURNING STOVES, UL 896;
- (w) HEATERS, ELECTRIC AIR, UL 1025;
- (x) HEATING EQUIPMENT, ELECTRIC BASEBOARD, UL 1042;
- (y) HEATING EQUIPMENT, ELECTRIC CENTRAL AIR, UL 1096; and
- (z) ROOM HEATERS, SOLID-FUEL TYPE, UL 1482.

Note: The table on the following page is a tabular summary of UL 296 and UL 795.

TABULAR SUMMARY UL STANDARD 296 AND UL STANDARD 795

| FUNCTION/BURNER INPUTS | OIL BURNERS UL 296 | | | | COMMERCIAL/INDUSTRIAL GAS UL 795 | | | | |
|--|----------------------------------|-----------------------------------|------------------------------------|------------------------------|------------------------------------|--------------------------------|---------------------------------|-----------------------|-----------------------|
| | 3 GPH 400,000 Btu or less | 7 GPH 1 million Btu or less | 20 GPH 3 million Btu or less | Over 20 GPH 3 million Btu | Mechanical Draft Burners | | | | ATM Draft |
| | | | | | Over 400,000 to 2,500,000 | Over 2,500,000 to 5,000,000 | Over 5,000,000 to 12,500,000 | Over 12,500,000 | |
| Prepurge timing | -- | -- | -- | -- | 4 | 4 | 4 | 4 | 90 sec ³ |
| Air changes | -- | -- | -- | -- | 4 | 4 | 4 | 4 | -- |
| Interlock Controls (Recycle) | Yes ⁸ | Yes ⁸ | Yes ⁸ | Yes ⁸ | Yes | Yes | Yes | Yes | Yes |
| Proven combustion air | Yes ⁸ | Yes ⁸ | Yes ⁸ | Yes ⁸ | Yes | Yes | Yes | Yes | Yes |
| Valve seal overtravel ⁹ | -- | -- | -- | -- | -- | Optional | Yes | Yes | 13 |
| Low gas pressure | -- | -- | -- | -- | -- | Yes ²⁰ | Yes ²⁰ | Yes ²⁰ | 13 |
| High gas pressure | -- | -- | -- | -- | -- | Yes ²⁰ | Yes ²⁰ | Yes ²⁰ | 13 |
| Low fire start | 11 | 11 | 11 | 11 | 11 | 11 | 11 | 11 | 13 |
| High limit (press. or temp.) | Yes | Yes | Yes | Yes | Yes | Yes | Yes | Yes | Yes |
| Low water cutoff | Boilers ²¹ | Boilers ²¹ | Boilers ²¹ | Boilers ²¹ | Boilers | Boilers | Boilers | Boilers | 13 |
| Pilot - Intermittent | Optional | Optional | Optional | -- | Optional | Optional | Optional | Optional | 12 |
| Pilot - Interrupted | 19 | 19 | 19 | Yes ⁵ | Optional | Optional ² | Optional ² | Optional ² | 2, 10 |
| Direct spark ignition | Yes | Yes | Yes | 5 | -- | -- | -- | -- | -- |
| System & sequence approved safety control | Yes | Yes | Yes | Yes | Yes | Yes | Yes | Yes | Yes |
| Approved safety shutoff valves (SSOV) | IN | BURNER | DESIGN | -- | Yes ¹⁴ | Yes ¹⁴ | Yes ¹⁴ | Yes ¹⁴ | Yes ^{13, 14} |
| No vent valve | -- | -- | -- | -- | -- | -- | -- | Yes | 13 |
| Pilot valve | 18 | 18 | 18 | Yes | Yes ⁵ | Yes | Yes | Yes | Yes |
| Proved pilot | Optional | Optional | Optional | Yes | Yes | Yes | Yes | Yes | Yes |
| Trial for pilot | 17 | 17 | 17 | 15 sec | 15 sec | 10 sec | 10 sec | 10 sec | 13 |
| Trial for main flame | 90 sec ^{2,17} | 30 sec ^{2, 17} | 15 sec ^{2, 17} | 10/30 sec ⁷ | 15 sec ²² | 10 sec | 10 sec | 10 sec | 13 |
| Flame failure response time | 90 sec ¹⁷ | 4 sec max ^{16,17} | 4 sec max ^{15,17} | 4 sec max | 4 sec max | 4 sec max | 4 sec max | 2 sec max | 13 |
| Valve closing time (max.) | 23 | 23 | 23 | 23 | 5 sec max | 1 sec max | 1 sec max | 1 sec max | 13 |
| Supervise main flame | 17 | 17 | 17 | Yes | -- | Yes ² | Yes ² | Yes ² | 2, 10 |
| Action on flame failure | Recycle optional ¹ | 1 | 1 | Lockout or recycle | Lockout or recycle ⁶ | Lockout | Lockout | Lockout | 13 |
| Action on limit open | Close SSOV | Close SSOV | Close SSOV | Close SSOV | Close SSOV | Close SSOV | Close SSOV | Close SSOV | 13 |

See following page for footnotes.

FOOTNOTES TO TABULAR SUMMARY UL
STANDARD 296 AND UL STANDARD 795:

SSOV = Safety shutoff valve.

¹May relight if ignition is re-energized within 0.8 sec. See 15 and 16.

²Where intermittent pilot is desired, it is allowable to switch from pilot detector to main flame detector if main flame detector responds to main flame only.

³Without shutters, no prepurge required.

⁴Options (whichever is chosen, a minimum of 4 air changes must be provided):

30 sec at high fire rate; OR

60 sec at $\frac{1}{2}$ high fire rate; OR

90 sec at $\frac{1}{3}$ high fire rate.

⁵With 2-stage lightoff, direct ignition is permitted if first stage is 20 gph or less (requirements for 20 gph or less apply). Pilot is required if igniting more than 20 gph.

⁶Lockout on interrupted pilot applications; recycle on intermittent pilot applications.

⁷10 sec for distillate fuel (No. 1 or No. 2); 30 sec for residual fuel (No. 4, 5, 6).

⁸Conventional type pressure burner — none needed. Needed for applications with combustion air supply separate from oil supply.

⁹Valve seal overtravel switch can be wired into either the start circuit or pre-ignition interlock circuit (if provided).

¹⁰Interrupted pilot over 2.5 million Btuh if modulating or high/low firing rate. Otherwise over 5 million Btuh.

¹¹If low fire start is not proved, UL will test for smooth lightoff at high fire.

¹²Intermittent up to 5 million Btuh unless firing rate control is over 2,500,000 Btuh.

¹³Requirements same as mechanical draft burners.

¹⁴See Table 1 at end of footnotes for main gas valves.

¹⁵Up to 15 sec is permitted if intermittent ignition is employed, or if the ignition system is re-energized in not more than 0.8 sec after flame is extinguished.

¹⁶Up to 30 sec is permitted if intermittent ignition is employed, or if the ignition system is re-energized in not more than 0.8 sec after flame is extinguished.

¹⁷If proved pilot igniter is used, timings for over 20 gal flame safeguard control may be applied.

¹⁸Required for electrically ignited, gas-piloted systems.

¹⁹Interrupted pilot may be required if using flame safeguard control with a proved pilot. Otherwise, interrupted pilot is optional.

²⁰Safety shutdown by this limit can be accomplished either by manual reset limits or in the programmer limit circuit.

²¹Required on boilers fired by oil burners — not a requirement of UL 296.

²²If intermittent pilot is used, no main burner flame-establishing period is required.

²³If a separate oil valve is used, it must close within 5 sec max when de-energized.

TABLE 1 — AUTOMATIC MAIN GAS SAFETY SHUTOFF VALVES (SSOV) FOR MECHANICAL OR ATMOSPHERIC BURNERS — UL 795 REQUIREMENTS, EFFECTIVE OCTOBER 1, 1974

| | 400,000 to 2,500,000 BTUH | Over 2,500,000 to 5,000,000 BTUH | Over 5,000,000 to 12,500,000 BTUH | Over 12,500,000 BTUH |
|---------------------------|---|--|--|--|
| Main Valve Requirement | One valve rated for safety shutoff services (SSOV). Closing time 5 sec. | Two SSOV's in series, or one SSOV of the type incorporating a valve seal overtravel interlock. Closing time 1 sec max. | Two SSOV's in series, one of which incorporates a valve seal overtravel interlock. Closing time 1 sec max. | Two SSOV's in series, one of which incorporates a valve seal overtravel interlock. When fuel gas has specific gravity of less than 1.0, include a N.O. $\frac{3}{4}$ inch or larger electrically operated valve in a vent line between the two SSOV's. |

APPENDIX B

The material contained in this appendix is for clarification purposes only. The information is for the benefit of fire department inspectors making inspections pursuant to s. 101.14 (2) (b), Stats. (See s. ILHR 50.02 Special Note #2)

| Rule Number | Topic of Rule | Subject of Investigation |
|---|---|---|
| Ch. ILHR 50 — Administration and Enforcement | | |
| 50.25 | Petition for Variance | 1. Fire Department Position Statement (form SB-8A) |
| Ch. ILHR 51 — Definitions and Standards | | |
| 51.047 | Fire Rated Door Assemblies in Fire Rated Construction | 1. Maintenance 2. Operation 3. Unobstructed |
| 51.047 (6) | Door Closing Devices (Fire Doors) | 1. Maintenance 2. Use of Fusible Link |
| 51.06 (3) | Foam Plastics (Thermal Barrier) | 1. Proper Type and Correct Installation 2. Maintenance |
| 51.15 (2) | Exit Doors | 1. Maintenance 2. Unobstructed |
| 51.15 (3) | Exit Hardware | 1. Proper Type 2. Signage 3. Security Locks and Key Locks Open During Occupied Periods |
| 51.15 (4) | Exit Doorway | 1. Proper Size and Type 2. Maintenance |
| 51.161 | Handrails | 1. Maintenance 2. Replacement, when Needed |
| 51.162 | Guardrails | 1. Maintenance 2. Replacement, when Needed |
| 51.165 | Stairway Identification | 1. Proper Posting 2. Proper Signage on Buildings Constructed After January 1, 1982 |
| 51.166 | Stairway Discharge | 1. Proper Type 2. Maintenance |
| 51.167 | Exiting Through Areas of Hazard | 1. Proper Type |
| 51.20 | Fire Escapes | 1. Maintenance |
| 51.21 | Standpipe & Hose Systems | 1. Correct Installation 2. Maintenance |
| 51.22 | Fire Extinguishers | 1. Proper Type 2. Location 3. Maintenance 4. Operational |
| 51.23 | Automatic Sprinklers | 1. Water Supply 2. Obstruction of Sprinkler Heads 3. Location of Fire Department Connection 4. Accessibility of Fire Department Connection |
| 51.24 (5) | Fire Alarm Systems | 1. Operation & Testing 2. Location of Pull Stations |

| Rule Number | Topic of Rule | Subject of Investigation |
|---|---|--|
| 51.245 | Smoke Detectors | 1. Correct Installation 2. Maintenance of Detectors 3. Operational |
| Ch. ILHR 52 — General Requirements | | |
| 52.01 | Fire Prevention, Detection and Suppression (High Rise Construction) | 1. Proper Installation 2. Maintenance 3. Operation and Testing |
| 52.011 | Automatic Fire Sprinkler Systems for Low Rise Buildings | 1. Proper Installation 2. Maintenance 3. Operation and Testing |
| 52.02 (2) | Fire Department Access Openings | 1. Proper Type, Size and Location 2. Maintenance |
| 52.07 | Atriums | 1. Proper Type 2. Smoke Control System 3. Maintenance 4. Test Reports |
| 52.19 | Gas and Oil Lamps | 1. Proper Type and Clearance 2. Maintenance |
| 52.20 | Electrical Work | 1. Electrical Check List |
| 52.21 | Location and Maintenance of Exits | 1. Maintenance |
| 52.22 | Repairs | 1. Conformance |
| 52.23 | Cleanliness | 1. Conformance |
| Ch. ILHR 53 — Structural Requirements | | |
| 53.63 (1) (a)-(c) | Firestops | 1. Maintenance |
| Ch. ILHR 54 — Factory, Office, Mercantile | | |
| 54.01(3) | Fire Door Closing Devices | 1. Maintenance 2. Operational |
| 54.02 | Number and Location of Exits | 1. Maintenance 2. Proper Exit Hardware |
| 54.06 | Exit Doors, Exit Lights | 1. Maintenance of Illumination |
| 54.07 | Passageways | 1. Maintain in Clear, Unobstructed Condition |
| 54.08 | Stairway Enclosure | 1. Maintenance |
| 54.11 | Lighting | 1. Maintenance of Illumination |
| 54.14 | Isolation of Hazards | 1. Maintenance |
| 54.145 | Fire Extinguishers | 1. For Buildings Constructed After January 1, 1982: A. Proper Type B. Location C. Maintenance D. Operational |
| 54.15 | Standpipes | 1. Maintenance |
| 54.17 | Fire Alarm | 1. Maintenance 2. Location of Pull Stations |
| 54.20 | No Smoking Signs | 1. Proper Posting |
| Ch. ILHR 55 — Theaters and Assembly Halls | | |
| 55.07 | Number and Location of Exits | 1. Maintenance of Illumination |

| Rule Number | Topic of Rule | Subject of Investigation |
|--|----------------------------|--|
| 55.08 | Type of Exits | 1. Maintenance 2. To be Clear and Unobstructed |
| 55.09 | Stairways | 1. Maintenance 2. To be Clear and Unobstructed |
| 55.10 | Exit Doorways and Doors | 1. See 51.15 |
| 55.11 | Exit Lights | 1. Maintenance of Illumination |
| 55.12 | Required Exit Width | 1. To be Unobstructed |
| 55.14 | Width of Aisles | 1. To be Unobstructed |
| 55.15 | Lobbies and Foyers | 1. To be Clear and Unobstructed |
| 55.17 | Obstructions | 1. Maintenance |
| 55.22 (3) | Proscenium Wall (Openings) | 1. Proper Type 2. Maintenance |
| 55.24 | Automatic Smoke Outlets | 1. Operation |
| 55.29 | Isolation of Hazards | 1. Maintenance of Enclosures |
| 55.33 | Standpipes | 1. Correct Installation 2. Maintenance |
| 55.33 (3) | Fire Extinguishers | 1. For Buildings Constructed After January 1, 1982: A. Proper Type B. Location C. Maintenance D. Operational |
| 55.43 | Openings | 1. Operational 2. Maintenance |
| 55.45 | Relief Outlets | 1. Maintenance |
| 55.46 | Electric Wiring | 1. Electrical Check List |
| 55.50 | Maintenance | 1. Elimination of Fire Hazard |
| Ch. ILHR 56— Schools and Places of Instruction | | |
| 56.03 | Smoke Detection | 1. For Existing Buildings with Basements not Protected by Automatic Sprinklers or Smoke Detectors as of January 1, 1982, Automatic Smoke Detector System in Basement Corridors by January 1, 1983. A. Correct Installation B. Maintenance of Detectors |
| 56.06 | Exit | 1. Maintenance |
| 56.06 (6) | Exit Lights | 1. Maintenance of Illumination |
| 56.07 | Required Exit Width | 1. To be Unobstructed |
| 56.09 | Passageways | 1. To be Unobstructed 2. Maintenance of Exit Doors |
| 56.15 | Isolation of Hazards | 1. Maintenance of Enclosure |
| 56.18 | Fire Extinguishers | 1. Proper Type 2. Location 3. Maintenance 4. Operational |
| 56.19 | Fire Alarms | 1. Operation of System 2. Location of Pull Stations |
| 56.20 | Standpipes | 1. Correct Installation 2. Maintenance |

| Rule Number | Topic of Rule | Subject of Investigation |
|---------------------------------------|---|--|
| 56.34 | Exit Doors and Lights | 1. Maintenance of Doors 2. To be Clear and Unobstructed |
| 56.38 | Fire Alarms | 1. Operational 2. Testing 3. Location of Pull Stations |
| 56.43 | Exit Doors and Exit Lights | 1. Maintenance of Doors 2. To Be Clear and Unobstructed |
| 56.46 | Fire Alarms | 1. Operational 2. Testing 3. Location of Pull Stations |
| Ch. ILHR 57 — Residential Occupancies | | |
| 57.01 (3) | Basement and Ground Floor Protection | 1. Proper Installation 2. Maintenance |
| 57.02 | Allowable Height and Area (Corridor Door Hold-Open Device, Access Roadways) | 1. Maintenance 2. Operational 3. Clear and Unobstructed |
| 57.03 | Number and Location of Exits | 1. Maintenance 2. Proper Exit Hardware |
| 57.05 | Type of Exits | 1. Maintenance 2. To be Clear and Unobstructed 3. Proper Illumination |
| 57.08 | Enclosure of Interior Stairways and Shafts | 1. Maintenance of Enclosure |
| 57.09 | Passageways | 1. To Be Clear and Unobstructed 2. Maintenance of Exit Doors |
| 57.10 | Illumination of Exits and Exit Signs | 1. Maintenance of Illumination and Signs |
| 57.14 | Isolation of Hazards | 1. Maintenance of Enclosure |
| 57.15 | Standpipes | 1. Correction Installation 2. Maintenance |
| 57.16 | Smoke Detectors - All Buildings Except CBRF | 1. For Existing Buildings Constructed Before May 23, 1978, Specified Smoke Detectors by January 1, 1983: A. Correct Installation B. Maintenance of Detectors 2. For Buildings Constructed After January 1, 1983: A. Correction Installation B. Maintenance of Detectors C. Interconnection of Corridor/Stairway Detectors to Required Manual Fire Alarm System D. Corridor/Stairway Smoke Detectors Provided with Emergency Power, if Required for the Building |
| 57.165 | Smoke Detectors — CBRF | 1. Correct Installation 2. Maintenance of Detectors 3. Interconnection of Stairway, Complete Corridor and Common Use Room Detectors 4. Interconnection of Sleeping Room Detectors if Smoking is Permitted |
| 57.17 | Fire Alarms | 1. Operation of Systems 2. Location of Pull Stations |

| Rule Number | Topic of Rule | Subject of Investigation |
|--------------------------------------|---|--|
| 57.18 | Fire Extinguishers | 1. For Buildings Constructed After January 1, 1982: A. Proper Type B. Location C. Maintenance D. Operational |
| 57.19 | Rowhouse (Living Unit Separation) | 1. Proper Installation 2. Maintenance |
| Ch. ILHR 58 — Health Care Facilities | | |
| 58.04-58.05 | Number, Type and Location of Exits | 1. Maintenance 2. Proper Exit Hardware |
| 58.06 | Stairs | 1. Maintenance 2. To Be Clear and Unobstructed 3. Proper Illumination. |
| 58.18 | Marking of Means of Egress | 1. Correct Signage 2. Proper Illumination |
| 58.20 | Key Locking Hardware | 1. Correct Hardware Type and Installation 2. Building Satisfies Rules for Detention and Correctional Facilities 3. Maintenance |
| 58.21-58.23 | Protection of Openings | 1. Maintenance |
| 58.24 | Isolation of Hazards | 1. Maintenance of Enclosure and Required Automatic Sprinkler System |
| 58.25 | Rubbish Chutes and Laundry Chutes | 1. Protection of Enclosure 2. Sprinkler System Maintenance |
| 58.27 | Detection, Alarm and Communication Systems | 1. Operational 2. Testing 3. Location of Pull Stations 4. Correct Installation 5. Maintenance |
| 58.28 | Standpipes | 1. Correct Installation 2. Maintenance |
| 58.29 | Automatic Sprinkler and Other Suppression Systems | 1. Water Supply 2. Obstruction of Sprinkler Heads 3. Location and Accessibility of Fire Department Connection |
| 58.30-58.31 | Smoke Barriers, Corridor Walls | 1. Correct Installation 2. Maintenance |
| Ch. ILHR 58 — Places of Detention | | |
| 58.48-58.49 | Number, Type and Location of Exits | 1. Maintenance 2. Proper Exit Hardware |
| 58.50-58.51 | Stairways and Smoke-proof Towers | 1. Maintenance 2. To Be Clear and Unobstructed 3. Proper Illumination |
| 58.575 | Emergency Lighting | 1. Proper Type 2. Maintenance |
| 58.58 | Marking of Means of Egress | 1. Correct Signage 2. Proper Illumination |
| 58.59 | Door Locks | 1. Correct Type and Installation 2. Maintenance |
| 58.60-58.61 | Protection of Openings | 1. Maintenance |
| 58.62 | Isolation of Hazards | 1. Maintenance of Enclosure |

| Rule Number | Topic of Rule | Subject of Investigation |
|---|-----------------------------------|--|
| 58.63 | Standpipes | 1. Correct Installation 2. Maintenance |
| 58.635 | Fire Extinguishers | 1. Proper Type 2. Location 3. Maintenance 4. Operational |
| 58.64 | Fire Alarms | 1. Operation of System 2. Location of Pull Stations |
| 58.65 | Automatic Smoke Detection Systems | 1. Correct Installation 2. Maintenance of Detectors |
| 58.67 | Smoke Barrier | 1. Correct Installation 2. Maintenance |
| Ch. ILHR 59 — Hazardous Occupancies | | |
| 59.13 | Type of Exits | 1. Maintenance 2. Proper Exit Hardware |
| 59.14 | Number and Type of Exits | 1. Maintenance 2. To Be Clear and Unobstructed |
| 59.17 | Enclosure of Stairways and Shafts | 1. Maintenance of Enclosures |
| 59.19 | Illumination Levels | 1. Proper Illumination |
| 59.21 | Isolation of Hazards | 1. Maintenance of Enclosures |
| 59.23 | Fire Protection | 1. Operation of System 2. Proper Type of Extinguisher 3. Location of Extinguisher 4. Extinguisher Operational 5. Water Supply 6. Obstruction of Sprinkler Heads 7. Location and Accessibility of Fire Department Connection 8. Maintenance of Systems |
| 59.24 | Fire Alarms | 1. Operation and Testing 2. Location of Pull Stations |
| Ch. ILHR 60 — Child Day Care Facilities | | |
| 60.12 | Doors | 1. Joint Inspection Made |
| 60.16 | Electrical Work | 1. Electrical Check List |
| 60.19 | Operating Features | 1. Owner Responsibility |
| 60.31 | Exiting | 1. Joint Inspection Made |
| 60.32 | Required Exit Width | 1. Width to be Unobstructed |
| 60.33 | Passageways | 1. Joint Inspection Made |
| 60.34 | Stair and Shaft Enclosure | 1. Joint Inspection Made |
| 60.35 | Fire Extinguisher | 1. Proper Type 2. Location 3. Maintenance 4. Operational |
| 60.36 | Fire Alarm System | 1. Operation and Testing 2. Location of Pull Station |
| 60.37 | Hazardous Areas | 1. Joint Inspection Made |
| 60.38 | Exit and Emergency Lighting | 1. Joint Inspection Made |

| Rule Number | Topic of Rule | Subject of Investigation |
|---|---|---|
| Ch. ILHR 61 — Community-Based Residential Facilities | | |
| 61.10 (1) (h) | Construction, Building and Site | 1. Maintenance |
| 61.10 (3) | Smoke Separation | 1. Maintenance |
| 61.12 | Exiting and Doors | 1. To be Clear and Unobstructed 2. Maintenance |
| 61.14 | Smoke Detection | 1. Correct Installation 2. Maintenance of Detectors |
| 61.18 (4) | Ramp Requirements | 1. Maintenance |
| 61.20 | Fire Extinguisher | 1. Proper Type 2. Location 3. Maintenance 4. Operational |
| 61.24 | Heating and Ventilating | 1. Maintenance |
| 61.25 | Electrical | 1. Electrical Check List |
| Ch. ILHR 62-Subch. I — Open Parking Structures | | |
| 62.26 | Number, Location and Type of Pedestrian Exits | 1. Maintenance |
| 62.29 | Illumination and Exit Lights | 1. Maintenance of Illumination and Exit Lights |
| 62.30 | Fire Protection | 1. Correct Installation of Standpipes |
| 62.32 | Isolation of Hazards | 1. Maintenance |
| Ch. ILHR 62-Subch. III — Tents | | |
| 62.46 | Fire Hazards | 1. Elimination of Fire Hazard |
| 62.47 | Exits | 1. Maintenance |
| 62.49 | Electrical Installation | 1. Proper Installation |
| 62.50 | Fire Extinguishing Equipment | 1. Proper Type 2. Location 3. Maintenance 4. Operational |
| 62.51 | Illumination, Exit Lights and Signs | 1. Maintenance of Illumination |
| Ch. ILHR 62-Subch. V — Assembly Seating Facilities | | |
| 62.72 | Inspection and Maintenance | 1. Proper Maintenance 2. Conformance With Rules |
| 62.75 | Means of Egress | 1. Maintenance 2. To Be Clear and Unobstructed |
| 62.78 | Isolation of Hazards | 1. Maintenance of Enclosure |
| 62.80 | Illumination and Emergency Lighting | 1. Proper Illumination |
| 62.81 | Fire Prevention | 1. Maintenance |
| Ch. ILHR 62 — Subch. VII — Pedestrian Access Structures Connecting Buildings | | |
| 62.98 | General Requirements Construction | 1. Protection of Openings 2. Maintenance |
| 62.99 | Exiting | 1. Maintenance 2. To Be Clear and Unobstructed |

| Rule Number | Topic of Rule | Subject of Investigation |
|----------------------------|---|---|
| Ch. ILHR 64 — HVAC | | |
| 64.08 | Exhaust Ventilation System | 1. Maintenance |
| 64.09 | Combustion Air Intakes | 1. Maintenance |
| 64.16 | Air Cleansing Devices | 1. Maintenance |
| 64.19 | Location of Outside Air Intakes and Exhausts for Mechanical Ventilating Systems | 1. Maintenance |
| 64.21 | Location of Equipment | 1. Proper Equipment 2. Maintenance |
| 64.22(5) | Unvented Space Heaters | 1. Use Prohibited |
| 64.22 (7) | Fireplaces and Fireplace Stoves | 1. Proper Installation 2. Maintenance 3. Operation and Testing |
| 64.23 (5) (a) and (b) | Piping | 1. Installation 2. Maintenance |
| 64.42 | Fire Dampers and Fire Curtains | 1. Maintenance |
| 64.45 | Chimneys, Smoke Stacks, Gas Vents, Mechanical Draft and Venting Devices | 1. Maintenance |
| 64.46 | Masonry Chimneys | 1. Maintenance |
| 64.47 | Metal Smokestacks | 1. Maintenance |
| 64.48 | Factory-Built Chimneys and Gas Vents | 1. Maintenance |
| 64.49 | Gas Vent | 1. Maintenance |
| 64.50 | Chimney and Vent Connectors | 1. Maintenance |
| 64.51 (4) | Fire Protection | 1. Correct Equipment 2. Proper Installation 3. Proper Clearances and Protection |
| 64.52(1) | Maintenance | 1. Inspection of Chimney After Fire Before Reuse |
| 64.61(2) | Repair Areas | 1. Maintenance |
| 64.62 (2) | Vehicle Service Buildings | 1. Maintenance |
| 64.63 (2) | Garages | 1. Maintenance |
| 64.67 (5) (e), (f) and (g) | Kitchens | 1. Maintenance |
| 64.67 (6) | Automatic Suppression Systems | 1. Correct System 2. Proper Installation 3. Maintenance and Operational |

APPENDIX C

The 1989 Wis. Act 335 requires the department to establish rules for public buildings such that adequate space is provided within or adjacent to buildings for the separation, temporary storage and collection of recyclable materials likely to be generated by the occupants of the building.

When verified amounts of previously generated recyclable materials are available, the following may be used to determine adequate space for the separation, temporary storage and collection of recyclable materials:

One cubic yard should be allocated for each 200 pounds of newspaper and mixed paper.

One cubic yard should be allocated for each 80 pounds of mixed or commingled recyclable materials.

The guidelines in the following table are provided for determining adequate space allocation when verified amounts of previously generated recyclable materials are not available. These guidelines are based on accumulation of recyclable materials likely to be generated by the building occupants for one week and one month, respectively.

Guidelines for Recommended Space Allocation
by Type of Building Occupancy^a

| Type of Building Occupancy | Space Allocation (cu. ft./1,000 sq. ft. floor area) | |
|--|--|--------------|
| | One Week | One Month |
| Assembly Hall, Theater | 2.2 | 10.0 |
| Child Day Care | | |
| with meals served | 4.5 | 20.0 |
| without meals served | 3.0 | 12.0 |
| Detention and Correctional | 13.5 | 60.0 |
| Garage | | |
| Storage | 0 | 0 |
| Repair | b | b |
| Health Care | | |
| Hospital | 13.5 | 60.0 |
| Clinic, without meals served | 8.0 | 36.0 |
| Nursing/Rest Home | 4.5 | 20.0 |
| Hotel, Motel | | |
| without meals served | 3.5 | 15.0 |
| Industrial | b | b |
| Library | 2.2 | 10.0 |
| Mercantile | | |
| Department Store, Shopping Mall | 9.0 | 40.0 |
| Grocery | 18.0 | 80.0 |
| Museum, Art Gallery | 2.2 | 10.0 |
| Office | 7.0 | 30.0 |
| Residential, multi-family dwelling | 9.0 | 40.0 |
| Restaurant or Food Service | c | c |
| School, Places of Instruction | 3.0 | 12.0 |
| Warehouse | b | b |

^a This information is to be used only as a guide in determining space allocation. Space allocation may differ from the listed value when using verified amounts of previously generated recyclable materials.

^b Varies with type of activity.

^c Varies with number of meals served and type of meal service.