

SECTION XX. Comm 82 Appendix is repealed and recreated to read:

Chapter Comm 82 APPENDIX

The material contained in this appendix is for clarification purposes only. The notes, illustrations, etc. are numbered to correspond to the number of the rule as it appears in the text of the code.

A-82.20 (2) AGENT MUNICIPALITIES. The department has designated the following municipalities the authority to review and approve plumbing plans and specifications for those plumbing installations located within the boundary limits of the municipality and which require approval under s. Comm 82.20.

Note: This list is maintained by the department and is subject to change.

Appleton, City of

100 N. Appleton St.
Appleton, WI 54911-4799
Phone (920) 832-6419
FAX (920) 832-6464

Kenosha, City of

Dept. of Housing
625 52nd St., Rm. 100
Kenosha, WI 53144
Phone (262) 653-4263
FAX (262) 653-4254

Eau Claire, City of

203 S. Farwell St.
Eau Claire, WI 54702
Phone (715) 839-4947
FAX (715) 839-4939

Madison, City of

215 Martin Luther King Jr. Blvd.
PO Box 2984
Madison, WI 53701-2984
Phone (608) 266-4561
FAX (608) 266-6377

Green Bay, City of

100 N. Jefferson St., Rm. 403
Green Bay, WI 54301
Phone (920) 448-3296
FAX (920) 448-3117

Milwaukee, City of

809 N. Broadway St.
Milwaukee, WI 53202
Phone (414) 286-3116
FAX (414) 286-8667

Greenfield, City of

7325 W. Forest Home Ave.
Greenfield, WI 53220
Phone (414) 329-5328
FAX (414) 543-9615

Oak Creek, City of

Public Works Inspection Div.
8640 S. Howell Ave.
Oak Creek, WI 53154
Phone (414) 768-6547
FAX (414) 768-9587

Janesville, City of *

18 N. Jackson St.
P.O. Box 5005
Janesville, WI 53547-5005
Phone (608) 755-3064
FAX (608) 755-3196

Oshkosh, City of

215 Church Ave.
Oshkosh, WI 54901
Phone (920) 236-5052
FAX (920) 236-5084

Sheboygan, City of

City Hall, 3rd Fl.
828 Center Ave.
Sheboygan, WI 53081
Phone (920) 459-3478
FAX (920) 459-3967

* Plans within this municipality may be submitted to the department or the agent.

A-82.20 (4) WATER QUALITY MANAGEMENT AGENCIES (WQM.) The following is a list of water quality management agencies and the areas they serve.

Note: This listing is maintained by the department of natural resources and may be updated periodically; see also <http://www.dnr.state.wi.us/org/water/wm/glwsp/facilities/rpc.htm>.

<u>AGENCY</u>	<u>AREAS SERVED</u>
Bay-Lake Regional Planning Commission 211 N. Broadway, Suite 211 Green Bay, WI 54303-2757 Phone: (414) 448-2820	Cities of Manitowoc (est. completion 9/01), Marinette, Sheboygan, Sheboygan Falls, Two Rivers (est. completion 9/01) Village of Kohler Towns of Erdman, Herman, Lima, Mosel, Peshtigo, Porterfield, Sheboygan, Sheboygan Falls, Wilson
Brown County Planning Commission 100 N. Jefferson Street, Room 608 Green Bay, WI 54301 Phone: (414) 448-3400	County of Brown
City of Beaver Dam Beaver Dam Engineer 205 S. Lincoln Avenue Beaver Dam, WI 53916 (920) 887-4600 ext. 326	City of Beaver Dam
City of Monroe 1110 18 th Avenue Monroe, WI 53566 (608) 329-2595	City of Monroe
City of Superior Administrative Engineer 1407 Hammond Avenue Superior, WI 54880 Phone: (715) 394-0691	City of Superior
Dane County Regional Planning Commission 30 W. Mifflin Street, Suite 403 Madison, WI 53703 Phone: (608) 266-4137	County of Dane (scheduled to terminate 9/30/04)
Dunn County Land Conservation 390 Red Cedar Street Menomonie, WI 54751 Phone: (715) 232-1496	City of Menomonie (sanitary sewer extensions only)
East Central Wisconsin Regional Planning Commission 132 Main Street Menasha, WI 54952 Phone: (414) 751-4770	Counties of Calumet, Fond du Lac, Green Lake, Marquette, Menominee, Outagamie, Shawano, Waupaca, Waushara, Winnebago,
LaCrosse/Onalaska Office of City Engineer 400 LaCrosse Street LaCrosse, WI 54601 Phone: (608) 789-7505	Cities of LaCrosse, Onalaska Towns of Campbell, Shelby
Marathon County Planning Department 210 River Drive Wausau, WI 54403-5449 Phone: (715) 261-6040	Cities of Schofield, Wausau Towns of Maine, Stettin, Texas, Wausau, Weston "Rib Mountain Metropolitan Sewerage District"; "Wausau Urban Area" Towns of Kronenwetter, Rib Mountain, Rothchild Village of Weston
North Central Wisconsin Regional Planning Commission 407 Grant Street Wausau, WI 54403 Phone: (715) 261-6565	City of Merrill

<u>AGENCY</u>	<u>AREAS SERVED</u>
<p>Oconto County/West Shore Oconto County Office of Land Use and Zoning 310 Washington Street Oconto, WI 54153-1621 Phone: (920) 834-6827</p>	<p>City of Oconto Towns of Abrams, Little River, Little Suamico, Oconto, Pensaukee, Stiles</p>
<p>Portage County Planning Department 1516 Church Street Stevens Point, WI 54481 Phone: (715) 346-1334</p>	<p>“Stevens Point Urban Area” City of Stevens Point Towns of Hull, Linwood, Plover Villages of Park Ridge, Plover, Whiting</p>
<p>River Falls Municipal Utilities 123 E. Elm Street Beaver Dam, WI 53916 (715) 425-0906</p>	<p>City of River falls</p>
<p>Rock County Planning Agency 51 South Main Street Janesville, WI 53545 Phone: (608) 757-5587</p>	<p>Cities of Janesville and Beloit Towns of Beloit, Harmony, LaPrairie, Janesville, Rock, Turtle Village of Chilton</p>
<p>Sauk County Planning and Zoning 505 Broadway Baraboo, WI 53913 (608) 355-3285</p>	<p>City of Baraboo</p>
<p>Southeastern Wisconsin Regional Planning Commission W239 N1812 Rockwood Drive P. O. Box 1607 Waukesha, WI 53187-1607 Phone: (414) 547-6721</p>	<p>Counties of Kenosha, Milwaukee, Ozaukee, Racine, Walworth, Washington, Waukesha</p>
<p>St. Croix County Planning Office 1101 Carmichael Road Hudson, WI 54016 Phone: (715) 286-4673</p>	<p>“Hudson Urban Area” City of Hudson Towns of Hudson, St. Joseph, Troy Villages of North Hudson, Wester ½ Town of Warren</p>
<p>Sturgeon Bay Utilities Utilities General Manager P.O. Box 259 230 East Vine Street Sturgeon Bay, WI 54235 Phone: (920) 746-2820</p>	<p>City of Sturgeon Bay</p>
<p>West Central Wisconsin Regional Planning Commission 800 Wisconsin Street, Mailbox 9 Eau Claire, WI 54703-3606 Phone: (715) 836-2918</p>	<p>“Chippewa-Eau Claire Metropolitan Planning Area” Cities of Altoona, Chippewa Falls, Eau Claire Towns of Brunswick, Hallie, Lafayette, Seymour, Tilden, Union, Washington</p>
<p>Wood County Planning 400 Market Street Wisconsin Rapids, WI 54495 Phone: (715) 421-8466</p>	<p>“Southern Wood County” City of Marshfield, Nekoosa, Wisconsin Rapids Towns of Cameron, Grand Rapids, Lincoln, Marshfield, McMillan, Port Edwards, Rudolph, Saratoga, Seneca, Sigel, Grant Villages of Biron, Hewitt, Port Edwards, Rudolph</p>

A-82.30 (4)-1. BRANCH INTERVALS.

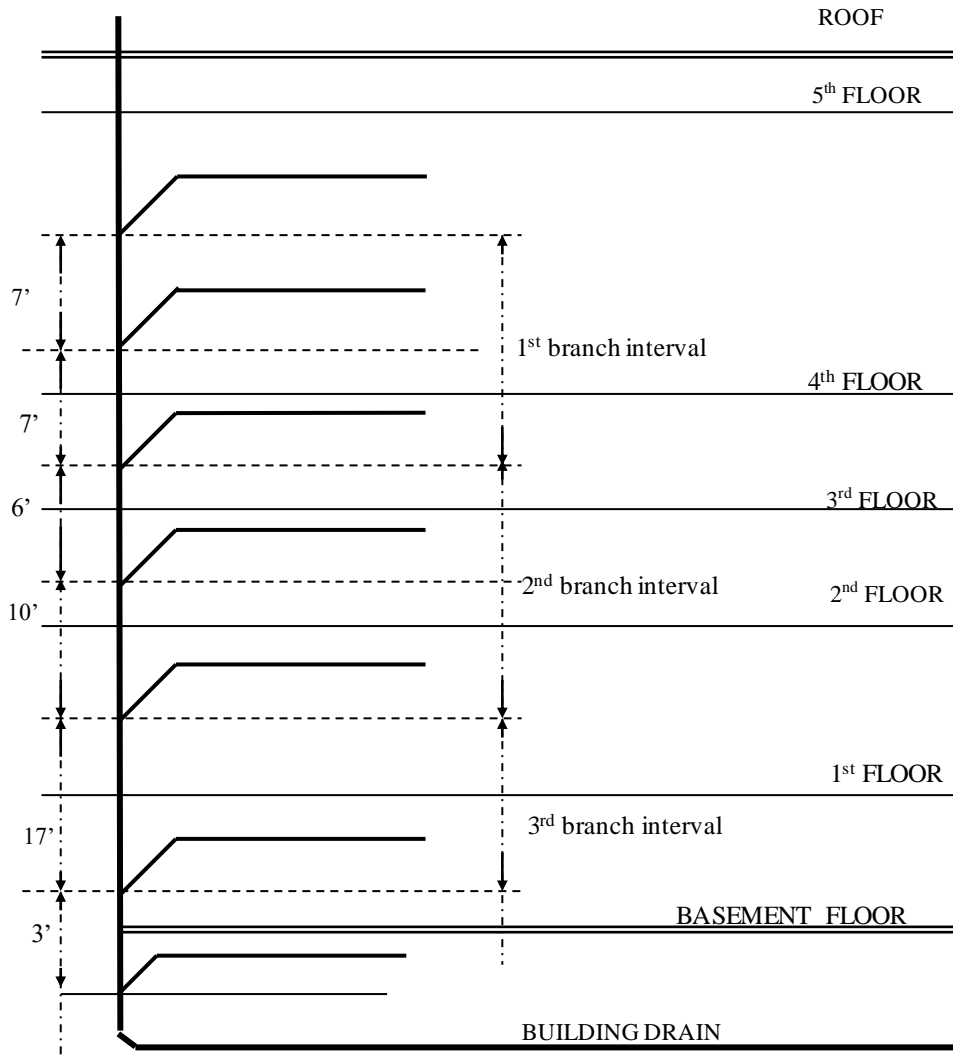

A-82.30 (4)-2. RECEPTOR DESIGN. The following table lists the gallons per minute (GPM) which can be expected to readily flow through a given size trap where the receptor has a height (H) as indicated.

Also listed is a drainage fixture unit (dfu) load which a given size receptor trap may be expected to adequately receive.

Note: A minimum individual 4-inch diameter trap and drain for a commercial type dishwasher is recommended.

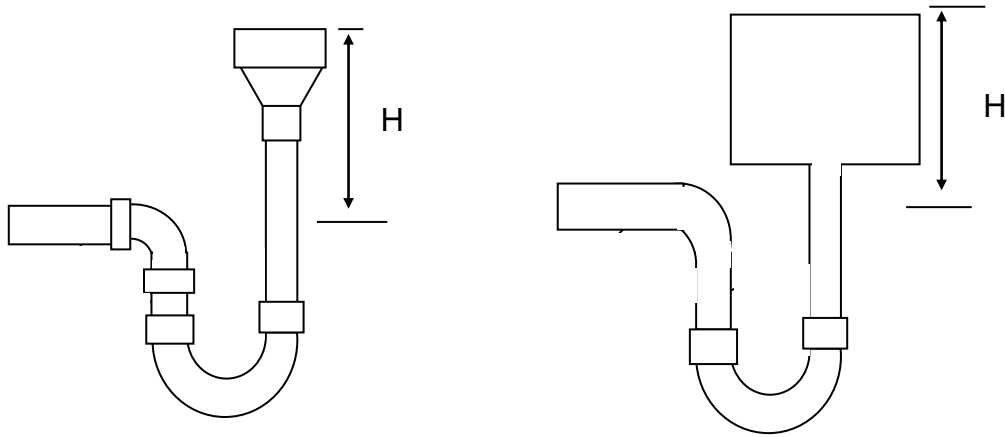

Receptor Trap Size (in inches)	H (in inches)	GPM	Drainage Fixture Units (dfu)
1 ½	12	4	2
2	14	8	4
3	15	12	6
4	17	40	20
5	20	70	35
6	22	120	60
8	25	250	125

A-82.30 (4)-3. Section NR 110.13 (2) (c) reads: "**NR 110.13 (2) (c) Slope.** 1. Conventional gravity sewers shall be laid with uniform slope between manholes. All sewers shall be designated and constructed to give average velocities of not less than 60 centimeters per second (2.0 feet per second) when flowing full. The minimum slopes in Table 1 shall be provided. Slopes less than 0.4% may be permitted for 20 centimeter (8 inch) sewers. In such cases, however, the slope may not be less than 0.3%. The department (DNR) will approve these sewers only when the owner demonstrates that physical circumstances warrant the lesser slope. Furthermore, approval will not be granted until the department (DNR) has received written assurance from the operating authority that the authority will provide the additional maintenance which may result from the sedimentation due to decreased velocities."

NR 110 Table 1

Sewer Size (in inches)	Minimum Slope (ft./100 ft.)
8 (20 cm)	0.40
10 (25 cm)	0.28
12 (30 cm)	0.22
15 (38 cm)	0.15
18 (46 cm)	0.12
21 (53 cm)	0.10
24 (61 cm)	0.08

A-82.30 (6) (b) OFFSETS IN VERTICAL DRAINS.

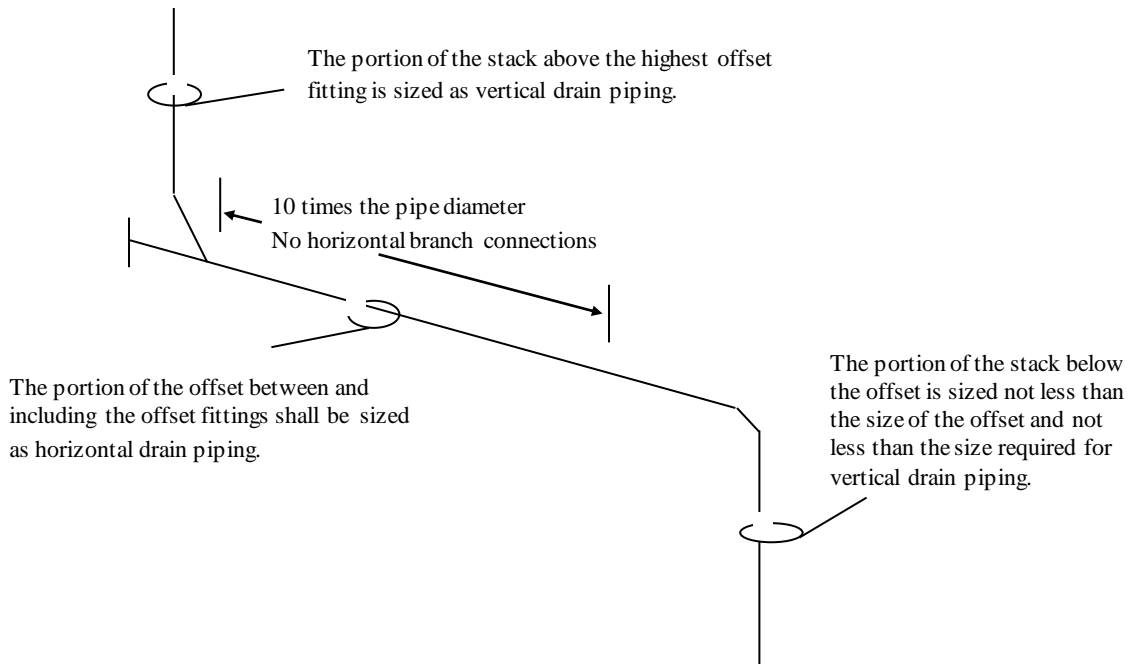

A-82.30 (7) HORIZONTAL BRANCH DRAIN CONNECTION AT BASE OF A STACK.

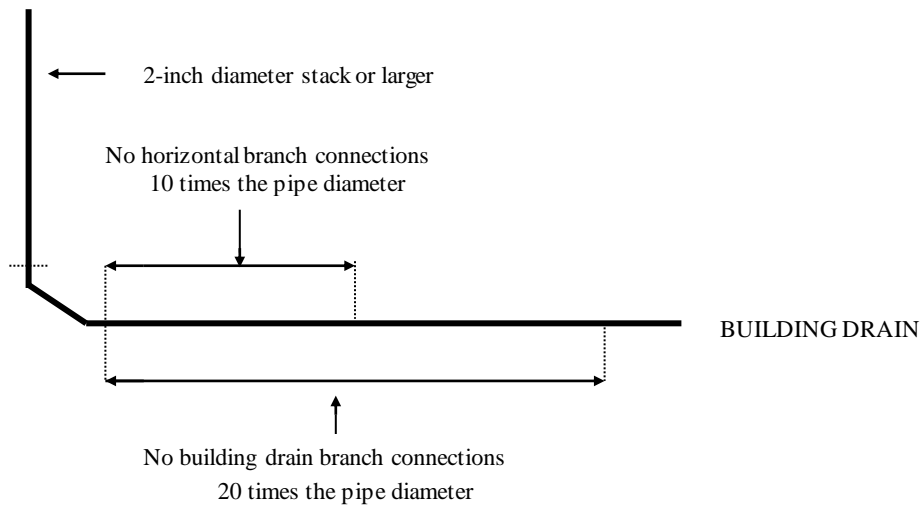

A-82.30 (8) MEASURING RADIUS OF A FITTING.

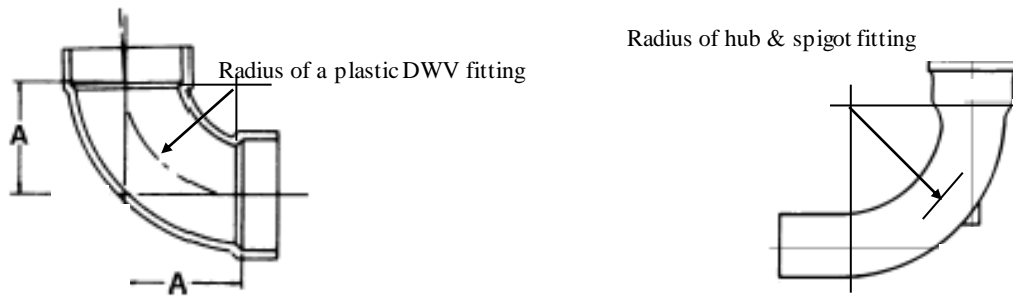

A-82.30 (10) (a) DETERMINING REQUIRED CAPACITY OF SANITARY SUMP.

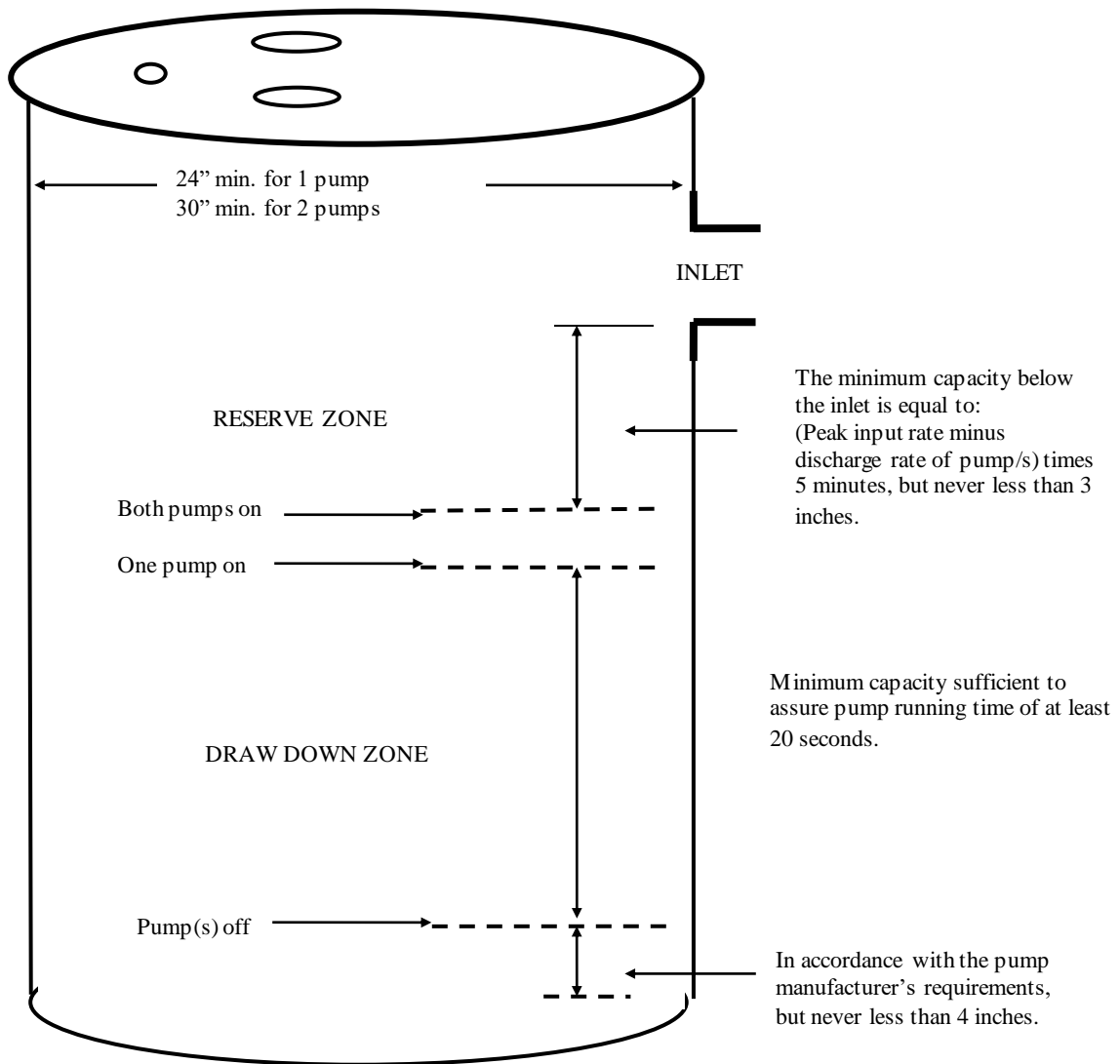

A-82.30 (10) (a) SUMPS.

**Capacity of sumps
(in gallons)**

Diameter of sump in inches	Volume in gal/ft	Diameter of sump in inches	Volume in gal/ft
24	23.5	41	68.6
25	25.5	42	72.1
26	27.6	43	75.5
27	29.7	44	79.1
28	32.0	45	82.7
29	34.3	46	86.5
30	36.8	47	90.2
31	39.2	48	94.0
32	41.8	54	119.0
33	44.5	60	147.0
34	47.2	66	178.0
35	50.0	72	211.5
36	52.8	78	248.4
37	55.9	84	288.1
38	59.0	90	330.8
39	62.1	96	376.3
40	65.3	108	477.3

A-82.30 (10) (b) 3. VELOCITY AND FLOW RELATIONSHIP MAINTAINING 2 FEET PER SECOND.

**Schedule 40 PVC
VELOCITY AND FLOW RELATIONSHIP
MAINTAINING 2 FEET PER SECOND**

Nominal Inside Diameter (in inches)	Actual Inside Diameter (in inches)	GPM creating 2 ft. per second
1 ¹ / ₄	1.38	9
1 ½	1.61	13
2	2.067	21
3	3.068	46
4	4.026	79

A-82.30 (11) (b) BUILDING DRAINS SERVING ANY BUILDING.

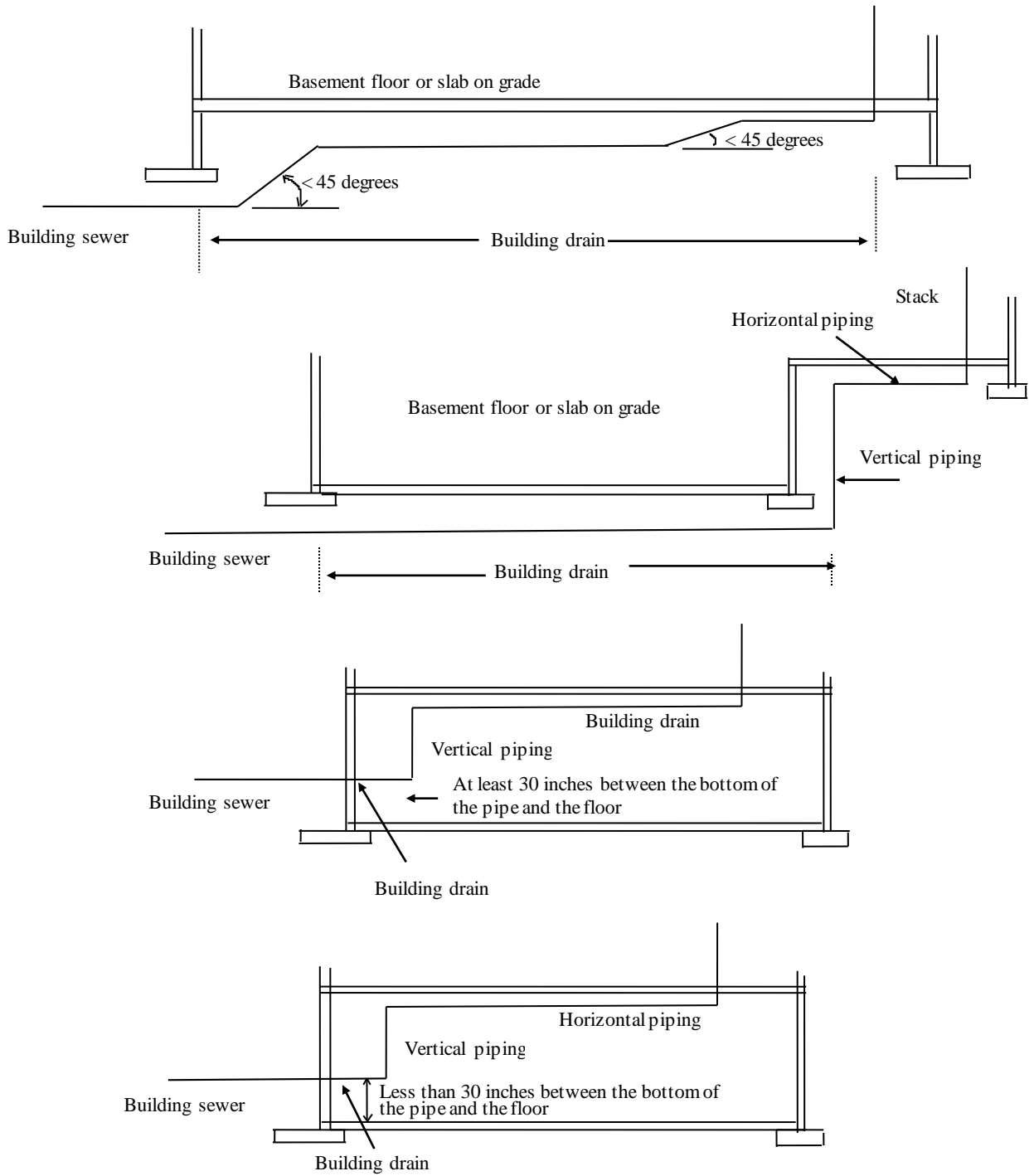

A-82.30 (11) (c) BUILDING SEWER INSULATION.

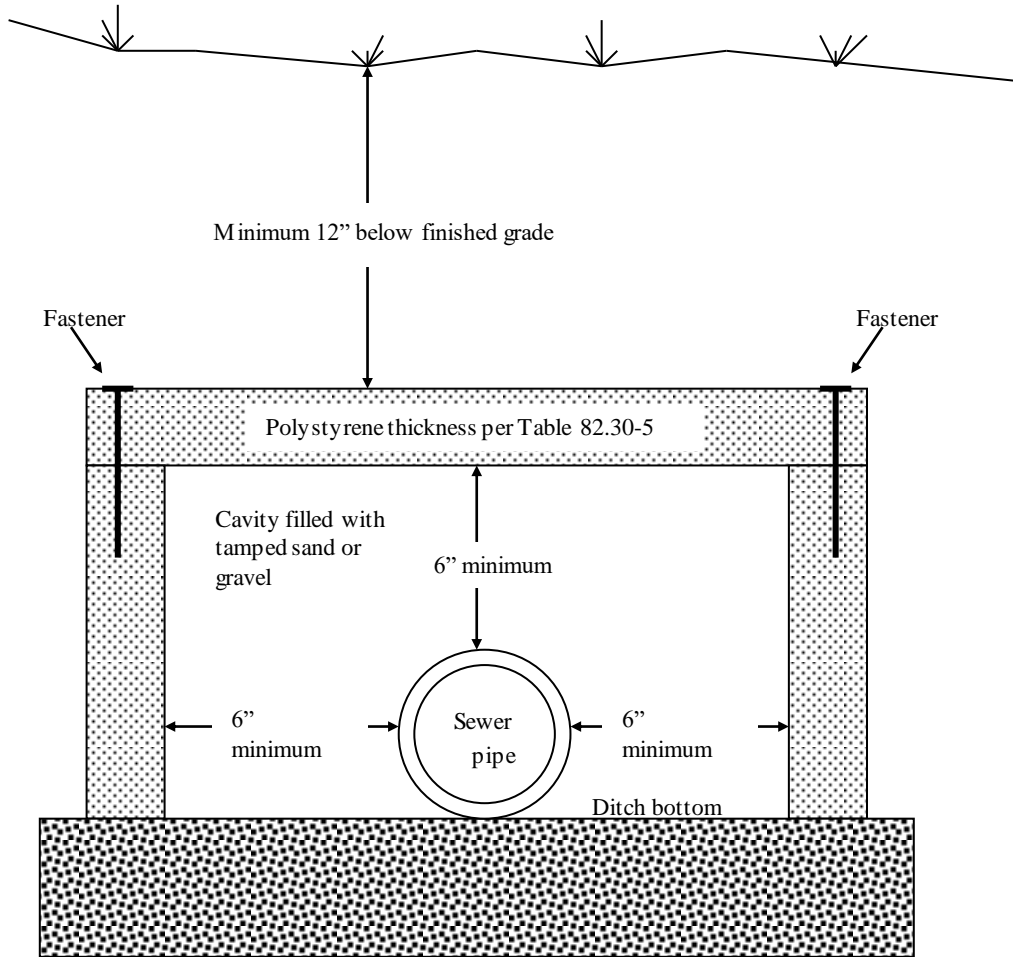

A-82.30 (11) (d) SETBACKS FOR VARIOUS CONTAMINANT SOURCES. Setbacks for various contaminant sources as specified in chs. NR 811 and NR 812 read:

“**NR 811.16 (4)** The well site shall be adequately separated from potential sources of contamination. Unless a hydrogeologic investigation indicates lesser separation distances would provide adequate protection of a well from contamination, the minimum separation distances provided shall be:

1. Fifty feet between a well and a storm sewer main.
2. Two hundred feet between a well and any sanitary sewer main, lift station or single family fuel tank. A lesser separation distance may be allowed for sanitary sewer mains where the sanitary sewer main is constructed of water main materials and joints and pressure tested in place to meet current AWWA C600 specifications. In no case may the separation distance between a well and a sanitary sewer main be less than 50 feet.
3. Four hundred feet between a well and a septic tank or soil adsorption unit receiving less than 8,000 gallons per day, a cemetery or a storm water drainage pond.
4. Six hundred feet between a well and any gasoline or fuel oil storage tank installation that has received written approval from the Department of Commerce or its designated agent under s. Comm 10.10.
5. One thousand feet between a well and land application of municipal, commercial or industrial waste; the boundaries of a landspreading facility for spreading of petroleum-contaminated soil regulated under ch. NR 718 while that facility is in operation; industrial, commercial or municipal waste water lagoons or storage structures; manure stacks or storage structures; and septic tanks or soil adsorption units receiving 8,000 gallons per day or more.
6. Twelve hundred feet between a well and any solid waste storage, transportation, transfer, incineration, air curtain destructor, processing, wood burning, one time disposal or small demolition facility; sanitary landfill; any property with residual ground-water contamination that exceeds ch. NR 140 enforcement standards that is shown on the department’s geographic information system registry of closed remediation sites; coal storage area; salt or deicing material storage area; gasoline or fuel oil storage tanks that have not received written approval from the department of industry, labor and human relations or its designated agent under s. Comm 10.10; bulk fuel storage facilities; and pesticide or fertilizer handling or storage facilities.

Note: Sites that have been closed with groundwater enforcement standard exceedances can be found on the Department of Natural Resource's GIS Registry of Closed Remediation Sites, at <http://www.dnr.state.wi.us/org/aw/rr> on the DNR's internet site. Information that appears on the GIS Registry of Closed Remediation Sites can also be accessed by calling the nearest regional DNR office."

"NR 812.08 (4) RELATION TO CONTAMINATION SOURCES. Minimum separating distances between any new potable or nonpotable well, reservoir or spring and existing sources of contamination; or between new sources of contamination and existing potable or nonpotable wells, reservoirs or springs shall be maintained as described in this subsection. The minimum separating distances of this subsection do not apply to dewatering wells approved under s. NR 812.09 (4) (a). Greater separation distances may be required for wells requiring plan approval under s. NR 812.09. Separation distance requirements to possible sources of contamination will not be waived because of property lines. Minimum separating distances are listed in Table A and are as follows:

- (a) Eight feet between a well or reservoir and a:
 - 1. Buried gravity flow sanitary or storm building drain having pipe conforming to ch. Comm 84;
 - 2. Buried gravity flow sanitary or storm building sewer having pipe conforming to ch. Comm 84;
 - 3. Watertight clear water waste sump;
 - 4. Buried clear water waste drain having pipe conforming to ch. Comm 84;
 - 5. Buried gravity flow foundation drain;
 - 6. Rainwater downspout outlet;
 - 7. Cistern;
 - 8. Buried building foundation drain connected to a clear water waste drain or other subsoil drain;
 - 9. Noncomplying pit, subsurface pumproom, alcove, or reservoir;
 - 10. Nonpotable well;
 - 11. Fertilizer or pesticide storage tank with a capacity of less than 1,500 gallons, but only when the well is nonpotable;

Note: For potable wells see par. (d) 1.

- 12. Plastic silage storage and transfer tube;
- 13. Yard hydrant;
- 14. Swimming pool, measured to the nearest edge of the water; or
- 15. Dog or other small pet house, animal shelter or kennel housing not more than 3 adult pets on a residential lot.
- (b) Twenty-five feet between a well or reservoir and a:
 - 1. Buried grease interceptor or trap;
 - 2. Septic tank;
 - 3. Holding tank;
 - 4. Buried building drain or building sewer having pipe not conforming to ch. Comm 84, wastewater sump, or non-watertight clear water waste sumps;
 - 5. Buried pressurized sanitary building sewer having pipe conforming to ch. Comm 84;
 - 6. Buried gravity manure sewer;
 - 7. Lake, river, stream, ditch or stormwater detention pond or basin measured to the regional high water elevation in the case of a lake or stormwater detention pond, to the edge of the floodway in the case of a river or stream or to the edge in the case of a ditch or stormwater detention basin;
 - 9. Liquid-tight barn gutter;
 - 10. Animal barn pen with concrete floor;
 - 11. Buried pressurized sewer pipe conveying manure provided that the pipe meets ASTM specification D-2241, with standard dimension ratio of 21 or less or pressure pipe meeting the requirements of s. NR 110.13 (6) (f) or 811.62.
 - 12. Buried fuel oil tanks serving single family residences, including any associated buried piping;
 - 13. Discharge to ground from a water treatment device;
 - 14. Vertical shaft installed below grade used for intake of air for a heating or air conditioning system; or
 - 15. Buried sanitary or storm collector sewer serving 4 or fewer living units or having a diameter of 6 inches or less.

(c) Fifty feet between a well or reservoir and a:

- 1. Soil absorption unit receiving less than 8,000 gallons/day, existing, abandoned or alternate, but not including a school soil absorption unit;

Note: For school soil absorption units see par. (e); for soil absorption units receiving more than 8,000 gallons/day see par. (f) 3.

- 2. Privy;
- 3. Pet waste pit disposal unit;
- 4. Animal shelter;
- 5. Animal yard;
- 6. Silo;
- 7. Buried sewer used to convey manure having pipe conforming to ch. Comm 84 that does not meet the specifications in par. (b);
- 8. Liquid tight manure hopper or reception tank;
- 9. Filter strip;
- 10. Buried sanitary or storm collector sewer serving more than 4 living units or larger than 6 inches in diameter except that wells may be located or sewers installed such that a well is less than 50 feet, but at least 25 feet, from gravity collector sewers smaller than 16 inches in diameter or from force main collector sewers 4 inches or smaller in diameter provided that within a 50-foot radius of the well the installed sewer pipe meets the allowable leakage requirements of AWWA C600 and the requirements for water main equivalent type pipe as follows:

a. For sewers >4" diameter, but <16" diameter: PVC pipe >4" diameter, but <12" diameter shall meet AWWA C900 with elastomeric joints having a standard dimension ratio of 18 or less; PVC pipe >12" diameter, but <16" diameter shall meet AWWA C905 with elastomeric joints having a standard dimension ratio of 18 or less; Ductile iron pipe shall meet AWWA C115 or AWWA C151 having a thickness class 50 or more.

b. For sewers <3" diameter, the pipe shall be any rigid pipe in the ch. Comm 84 "Table for Pipe and Tubing for Water Services and Private Water Mains," including approved ABS, brass, cast iron, CPVC, copper (not including type M copper) ductile iron, galvanized steel, polybutylene (PB), polyethylene (PE), PVC, or stainless steel pipe.

11. An influent sewer to a wastewater treatment plant;
12. The nearest existing or future grave site in cemeteries;
13. Wastewater treatment plant effluent pipe;
14. Buried pressurized sewer having pipe not conforming to ch. Comm 84; or
15. Manure loading area.

Note: The minimum separating distance between a well or reservoir and a lift station is based on the presence of a sewer force main at the lift station.

(d) One hundred feet between a well or reservoir and a:

1. Bulk surface storage tank with a capacity greater than 1,500 gallons or any bulk buried storage tank regardless of capacity, including, for both surface or buried tanks, associated buried piping for any solid, semi-solid or liquid product but not including those regulated under par. (b) 12. This subdivision includes, but is not limited to petroleum product tanks, waste oil tanks and pesticide or fertilizer storage tanks not regulated under par. (a) 11. This subdivision does not include septic, holding and manure reception tanks, or liquified petroleum gas tanks as specified in ch. Comm 11.
2. Liquid-tight, fabricated manure or silage storage structure, in ground or at ground surface;
3. Wastewater treatment plant structure, conveyance or treatment unit; or
4. Dry fertilizer or pesticide storage building or area when more than 100 pounds of either or both materials are stored;
5. Well, drill hole or water system used for the underground placement of any waste, surface or subsurface water or any substance as defined in s. 160.01 (8), Stats.;
6. Stormwater infiltration basin;
7. Uncovered storage of silage on the ground surface;
8. Water-tight silage storage trench or pit; or
9. Lift station.

(e) Two hundred feet between a school well and a soil absorption unit receiving less than 8,000 gallons per day, existing or abandoned.

(ee) One hundred fifty feet between a well or reservoir and a temporary manure stack.

(f) Two hundred fifty feet between a well or reservoir and a:

1. Manure stack.
2. Earthen or excavated manure storage structure.

Note: Variances from the separating distances may be granted as specified in s. NR 812.43 for earthen storage and manure stacks constructed and maintained to the specifications of Soil Conservation Standards No. 425 or 312, respectively.

3. Soil absorption unit receiving 8,000 or more gallons per day, existing, abandoned, or alternate.
4. Sludge landspreading or drying area.
5. An earthen silage storage trench or pit.
6. Liquid waste disposal system including, but not limited to a treatment pond or lagoon, ridge and furrow system and spray irrigation system.

Note: Variance from this separating distance may be granted for treatment ponds or lagoons constructed and maintained to an approval granted under ch. NR 213.

7. Salvage yard.
8. A salt or deicing material storage area including the building structure and the surrounding area where the material is transferred to vehicles. This subdivision does not include bagged deicing material.
9. Solid waste processing facility.
10. Solid waste transfer facility.
11. The boundaries of a landspreading facility for spreading of petroleum-contaminated soil regulated under ch. NR 718 while that facility is in operation.

(g) Twelve hundred feet between a well or reservoir and:

1. The nearest edge of an existing, proposed or abandoned landfill, measured to the nearest fill area of abandoned landfills, if known, otherwise measured to the nearest property line;
2. The nearest edge of a coal storage area in excess of 500 tons; or
3. A hazardous waste treatment facility regulated by the department."

A-82.30 (11) (f) CONNECTION TO PRESSURIZED PUBLIC SEWER.

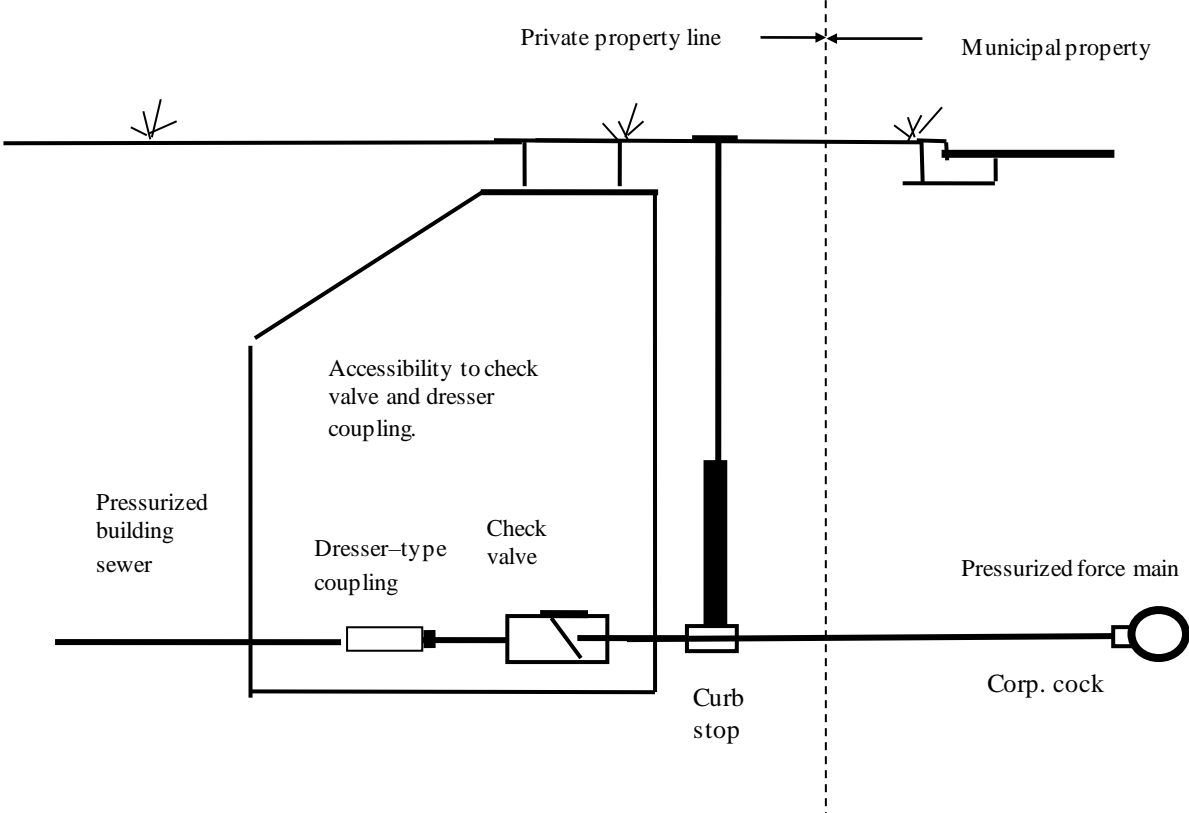

A-82.31 (4)-1. WHERE A VENT STACK AND STACK VENT ARE REQUIRED.

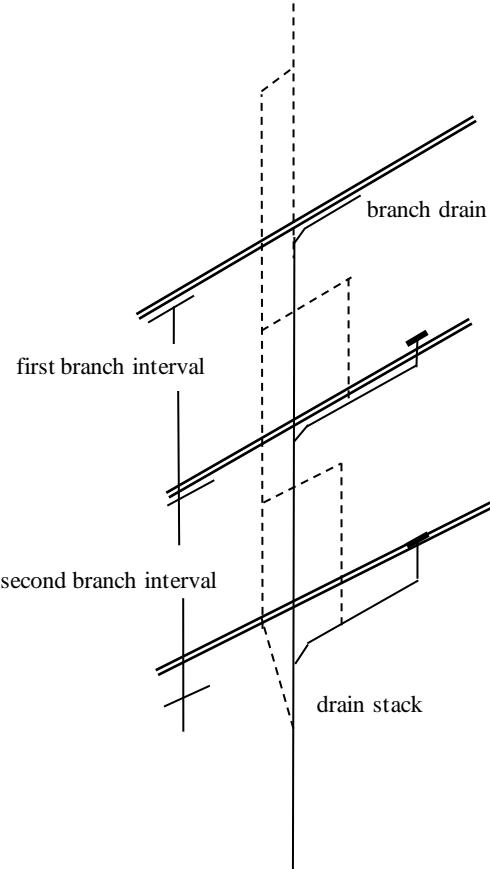

A-82.31 (4)-2. INSTALLATION OF VENT STACK AND STACK VENT.

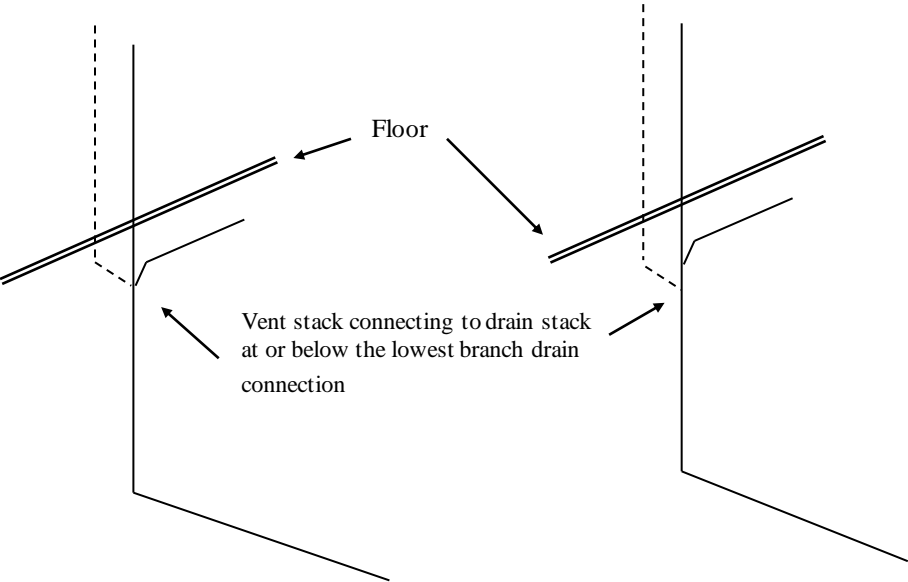

A-82.31 (4)-3. VENT STACKS AND STACK VENTS.

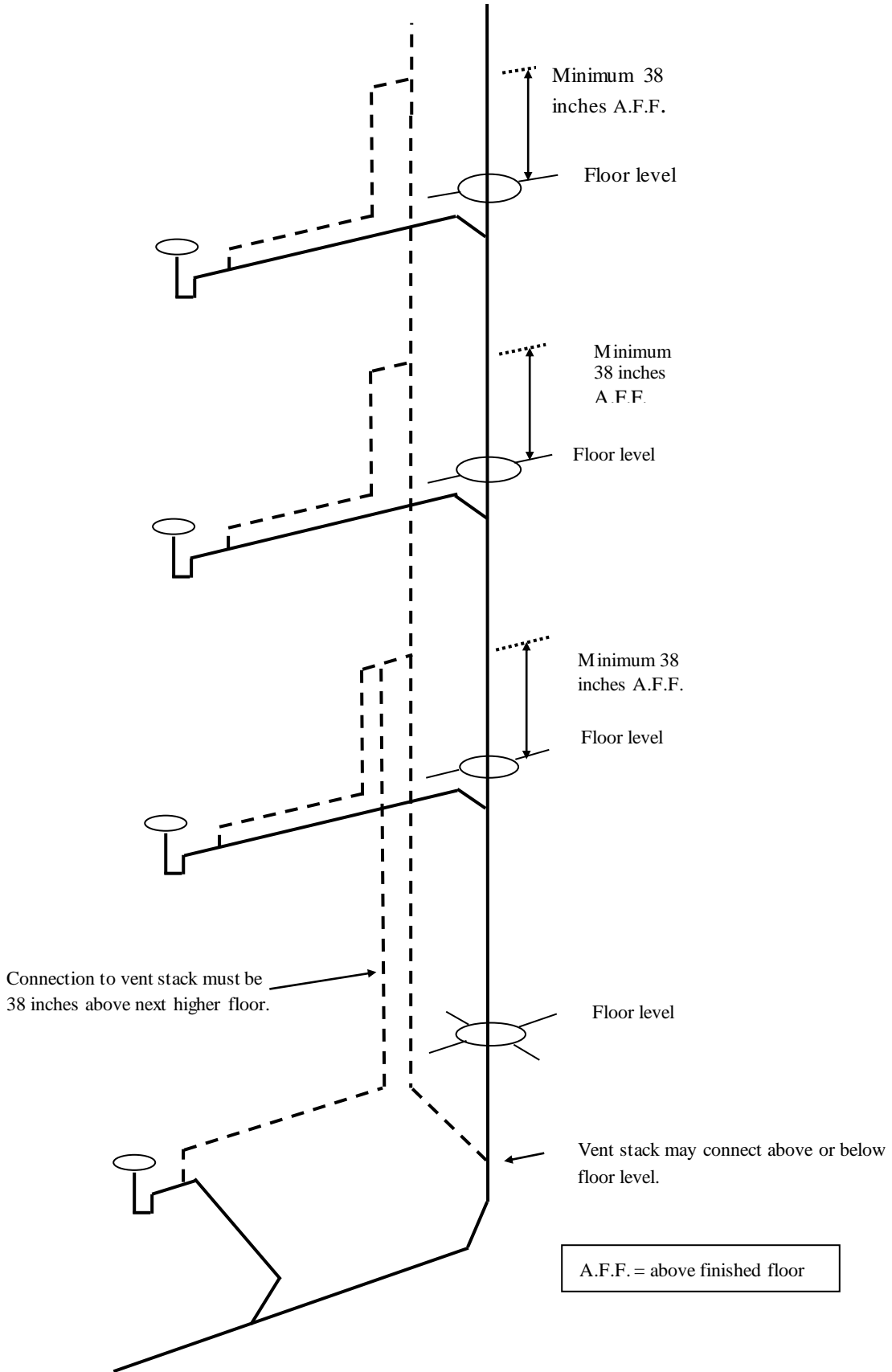

A-82.31 (4)-4. VENT STACKS AND STACK VENTS.

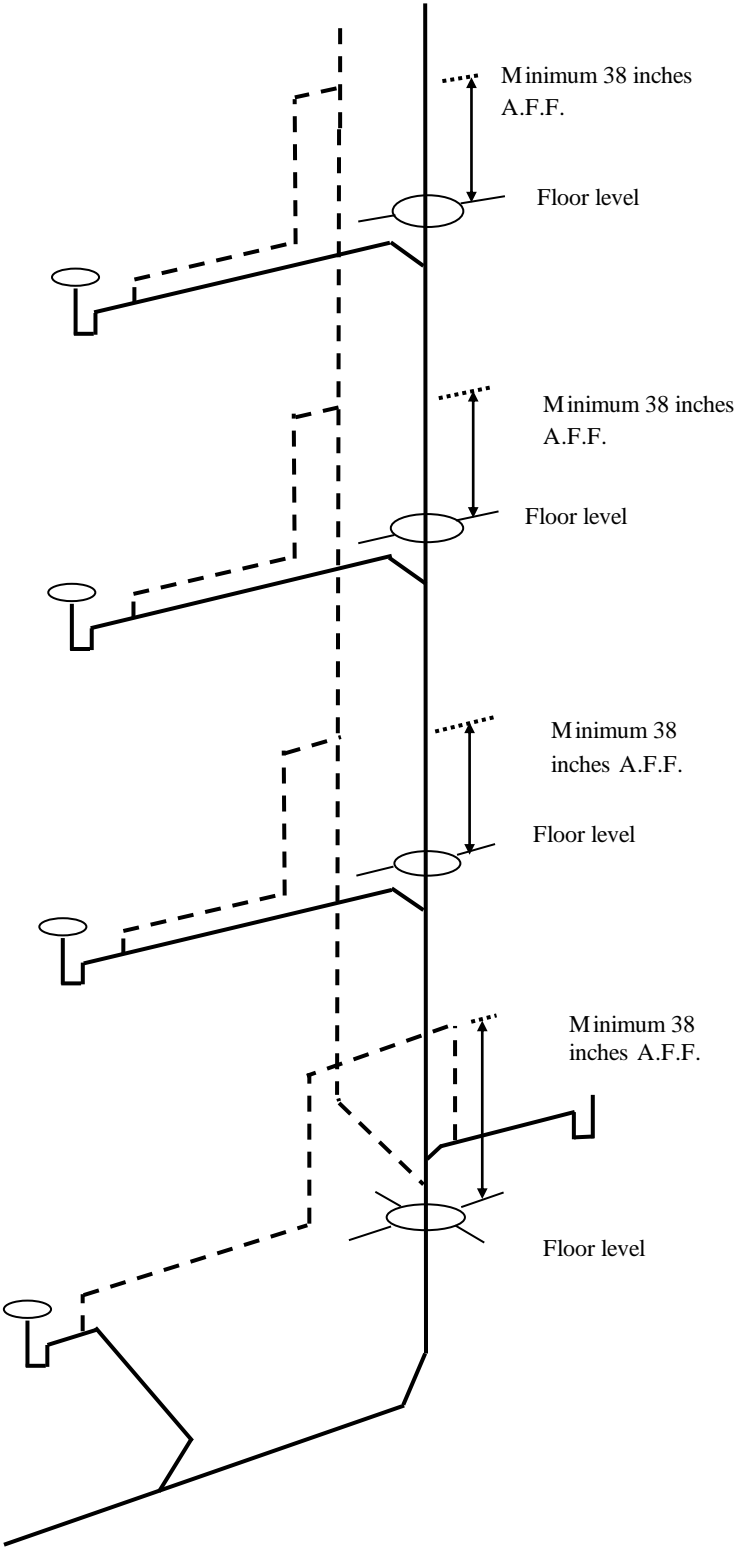

A-82.31 (4)-5. VENTS STACKS AND STACK VENTS.

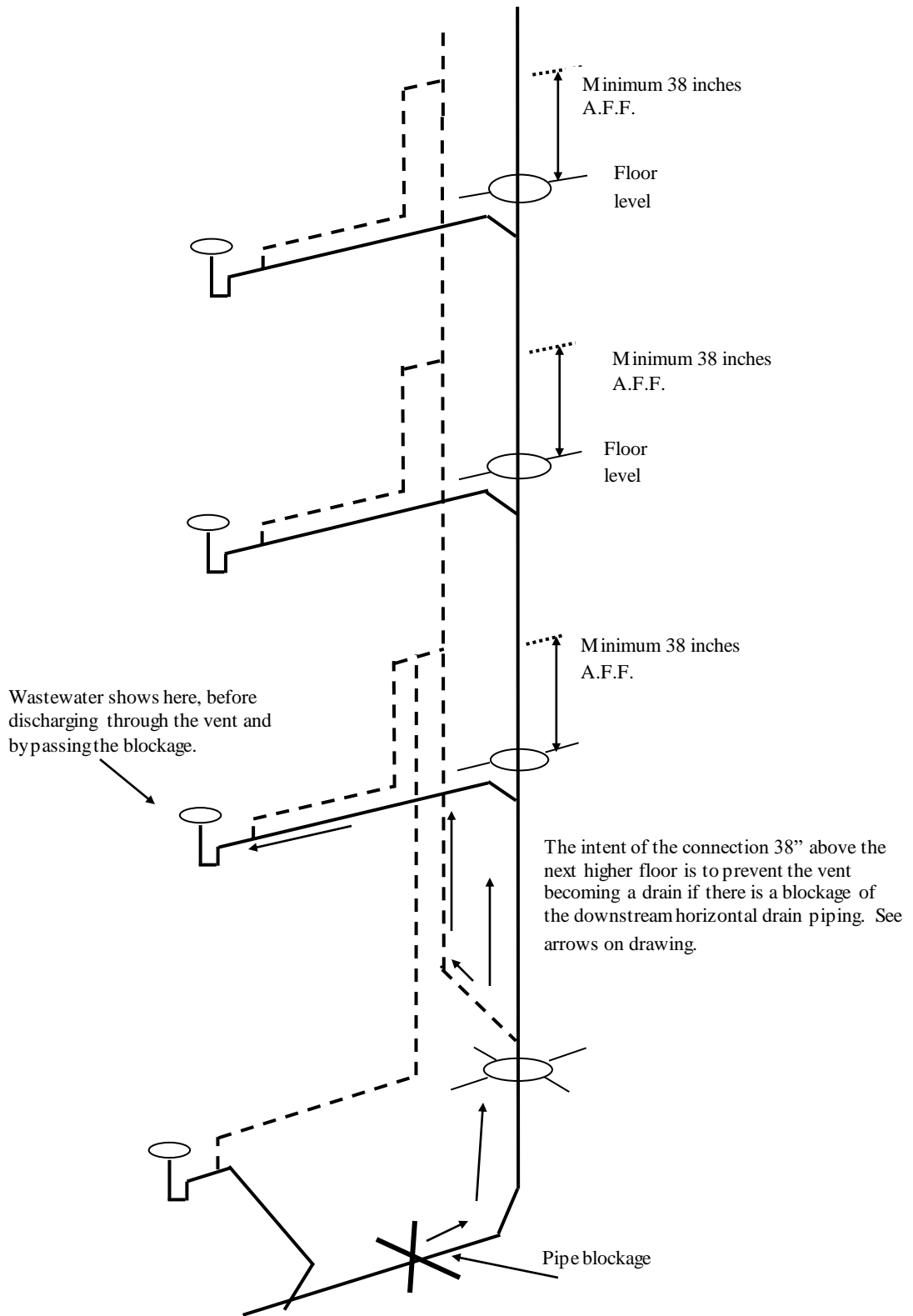

A-82.31 (5) (a) RELIEF VENT FOR OFFSETS OF 30 TO 45 DEGREES.

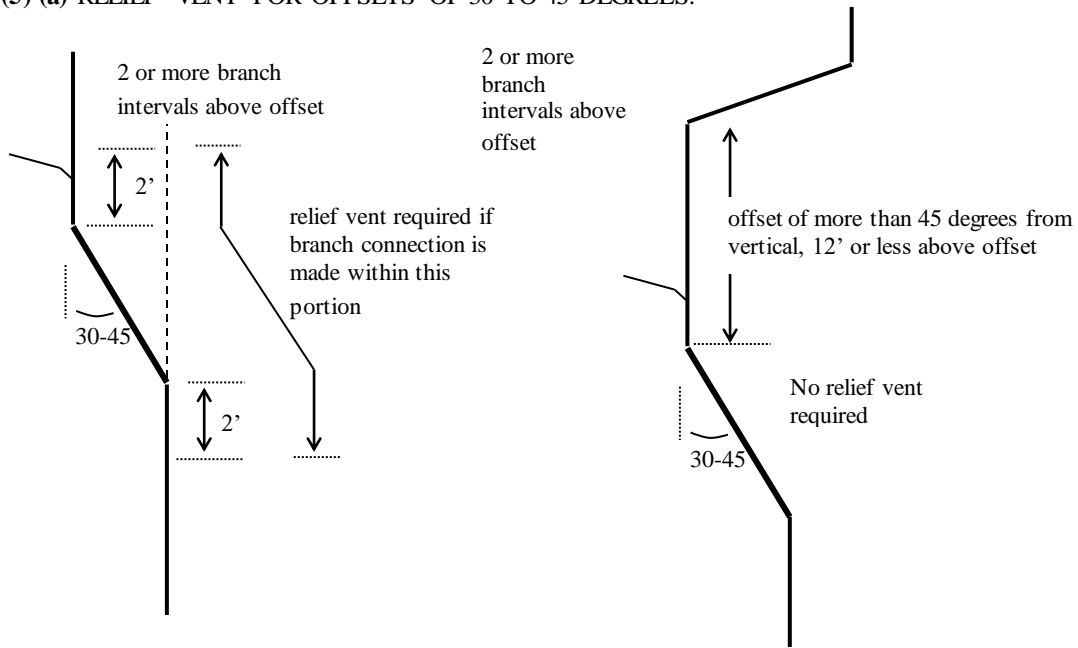

A-82.31 (5) (b) RELIEF AND YOKE VENTS FOR OFFSETS OF MORE THAN 45 DEGREES.

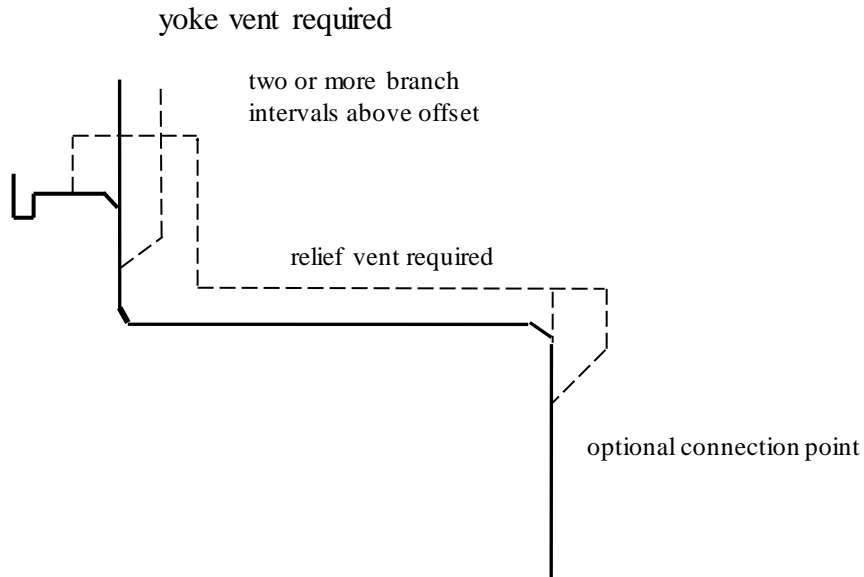

A-82.31 (7) RELIEF VENTS FOR BUILDING DRAINS.

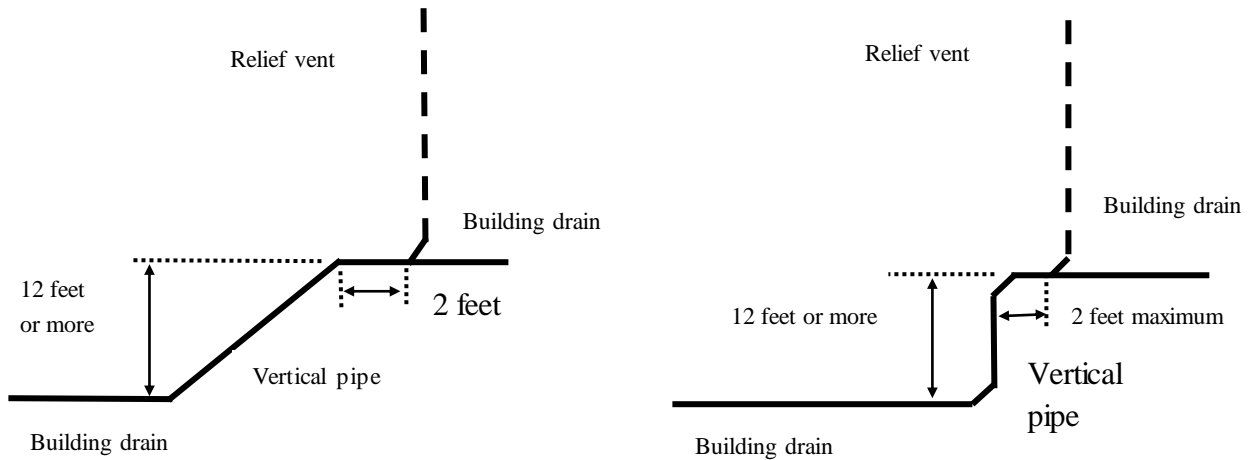

A-82.31 (9) FIXTURE VENTS.

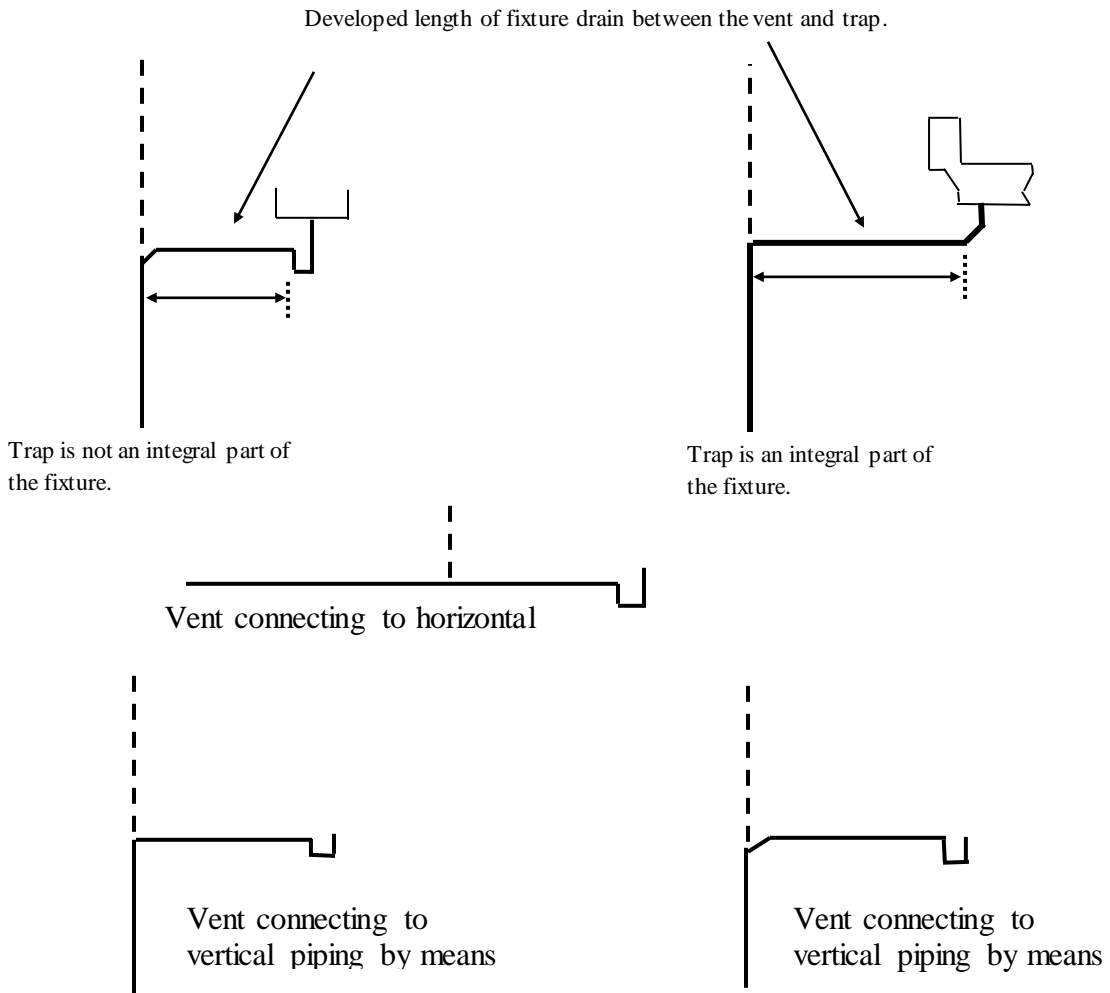

A-82.31 (10)-1. CIRCUIT VENTING.

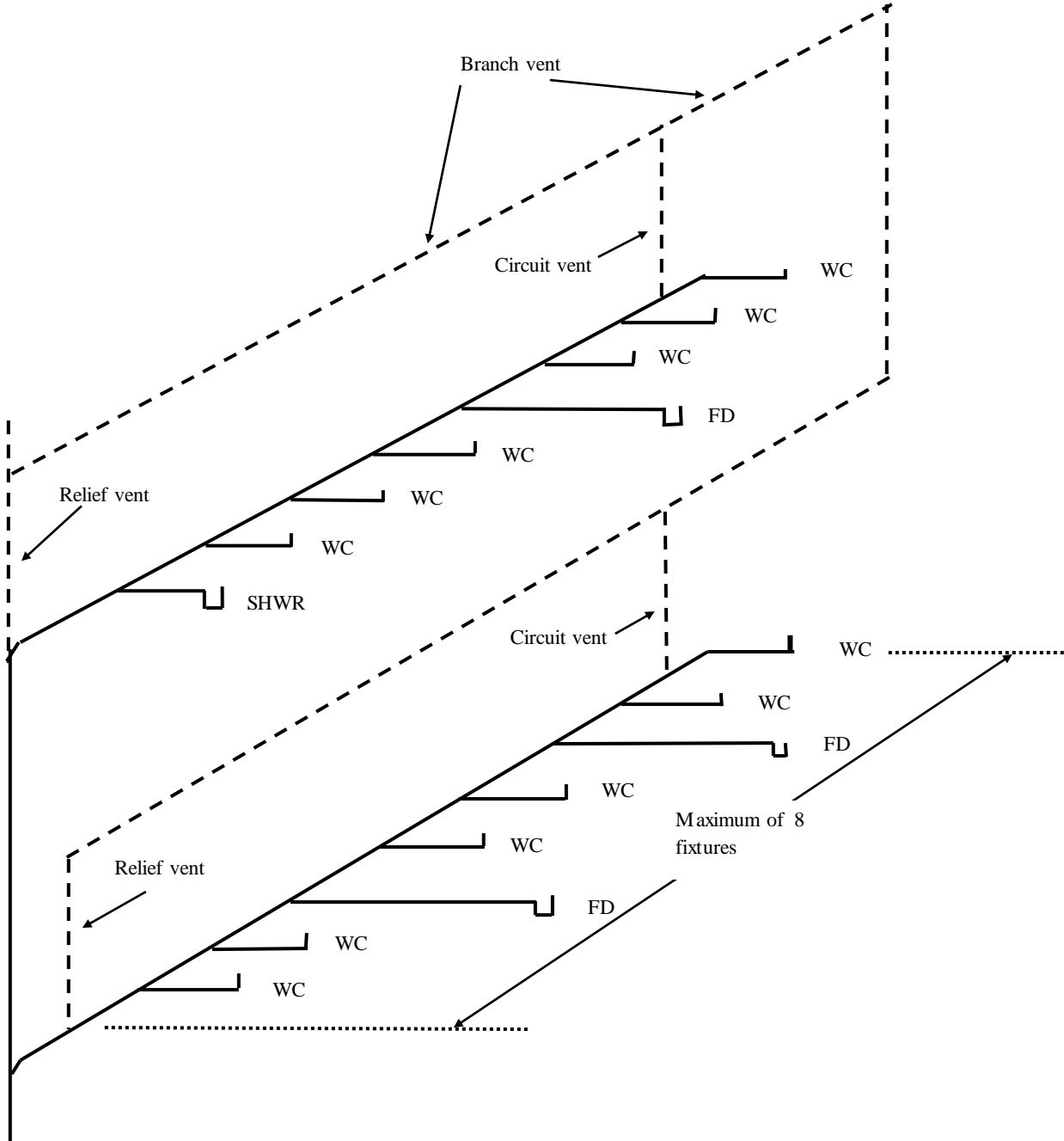

A-82.31 (10)-2. CIRCUIT VENTING.

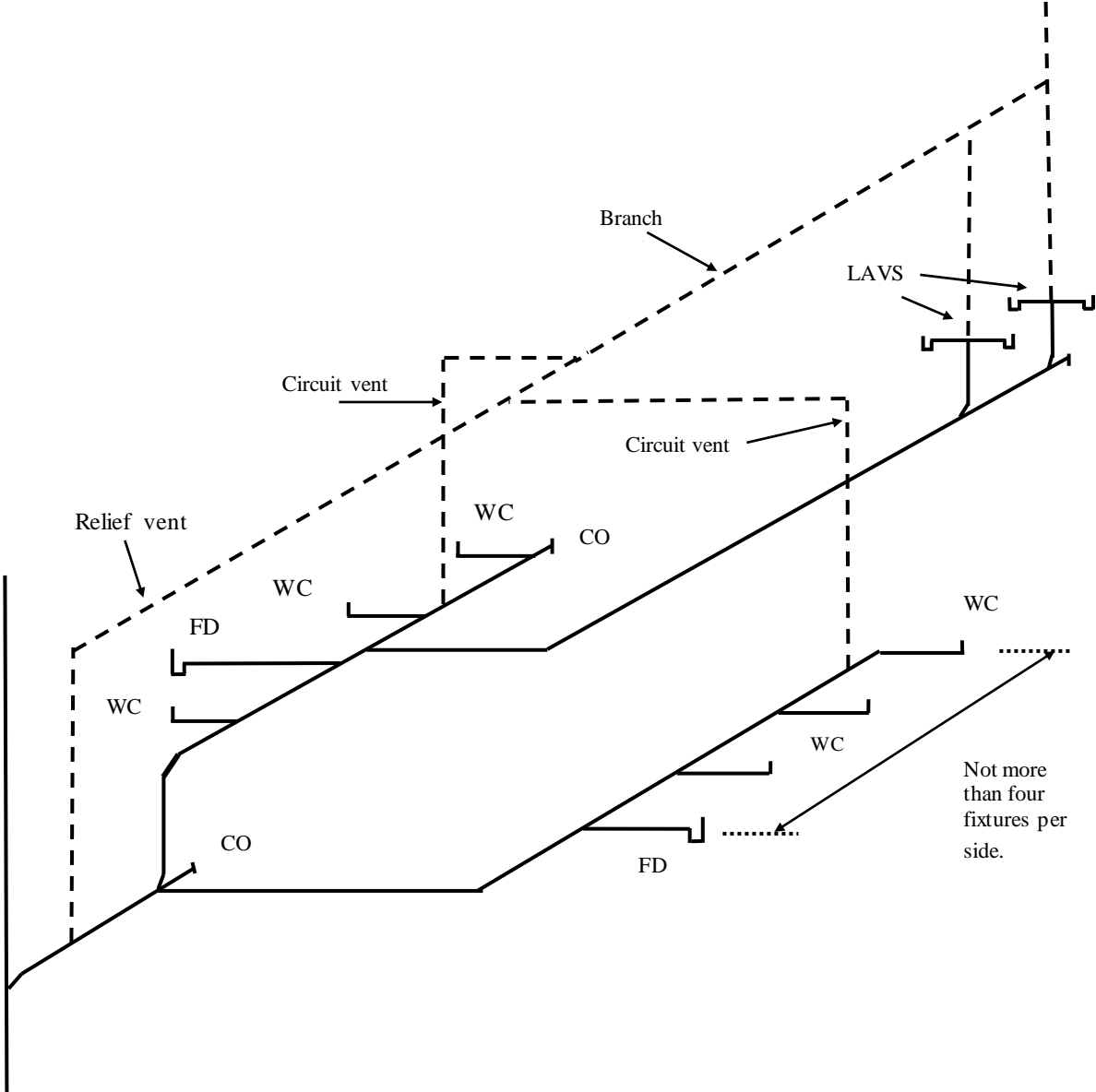

A-82.31 (10)-3. CIRCUIT VENTING.

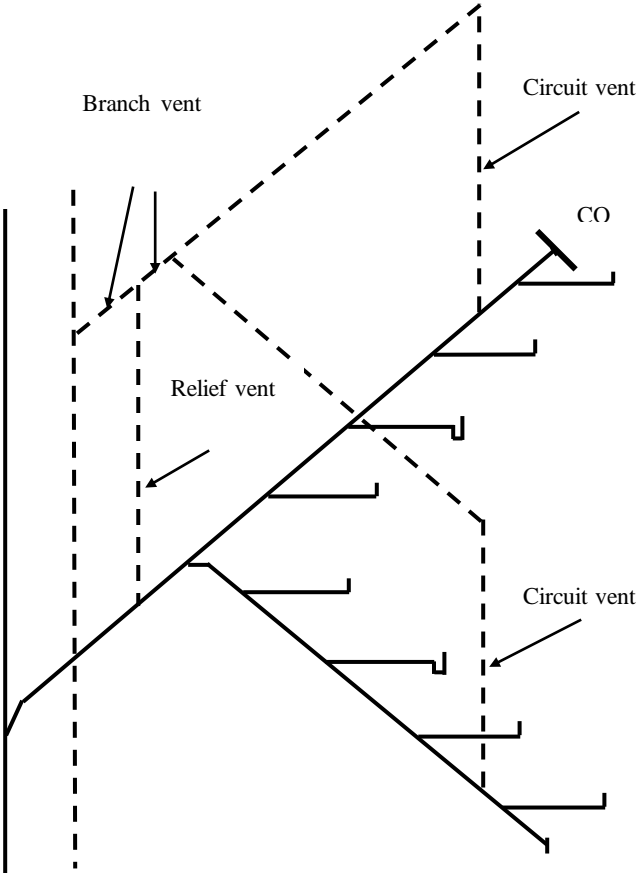

A-82.31 (10)-4. CIRCUIT VENTING.

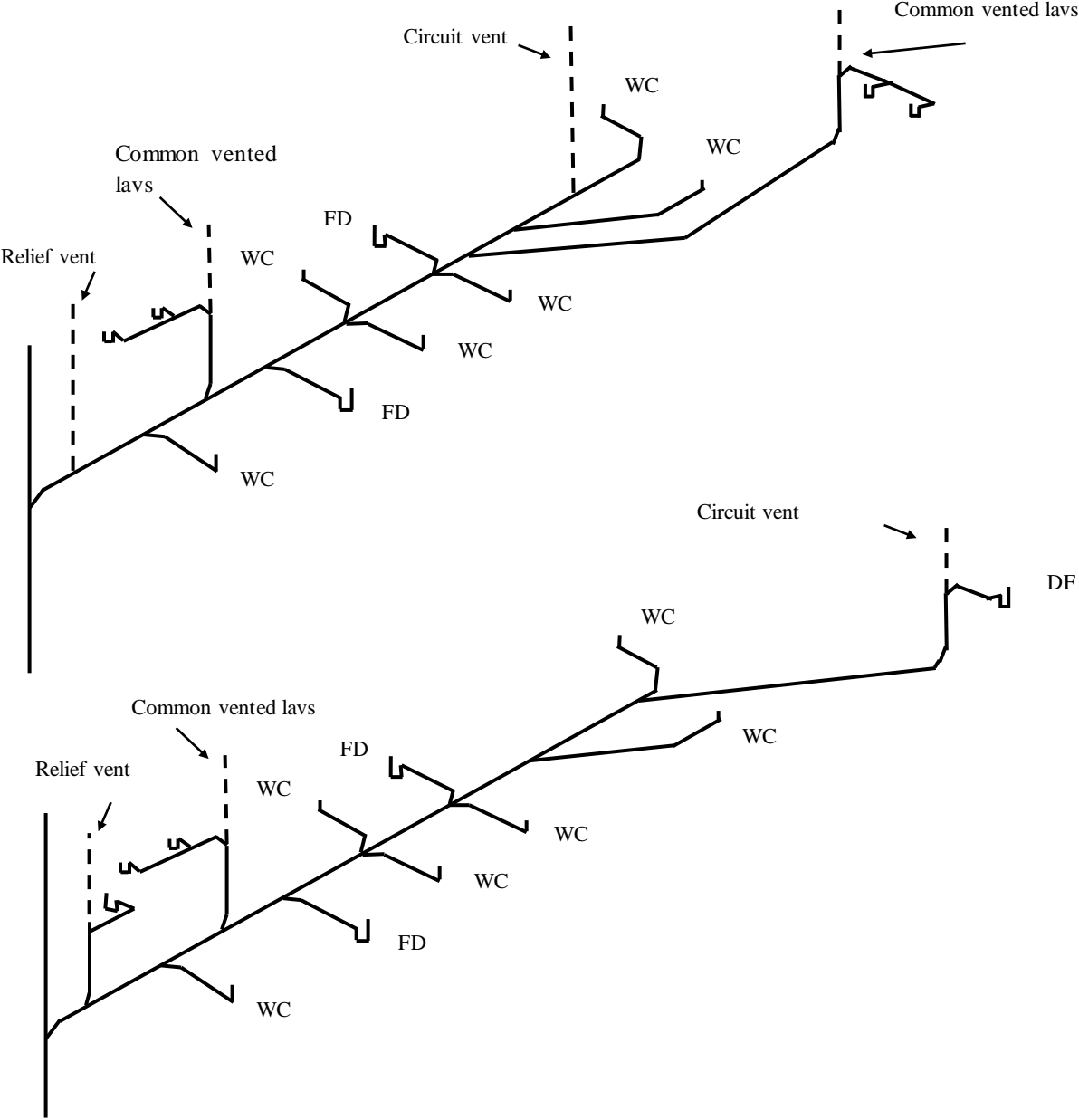

A-82.31 (11) (a) COMMON VENTS, VERTICAL, SERVING ANY TWO FIXTURES.

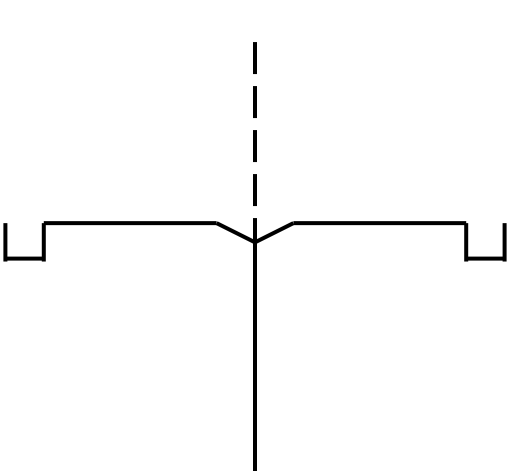

BACK-TO-BACK

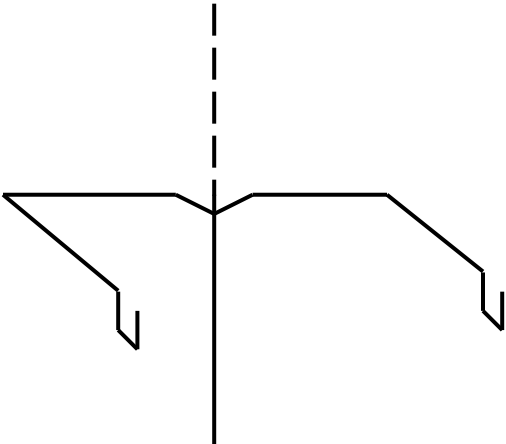

SIDE-BY-SIDE

A-82.31 (11) (b) COMMON VENTS, HORIZONTAL DRAINS.

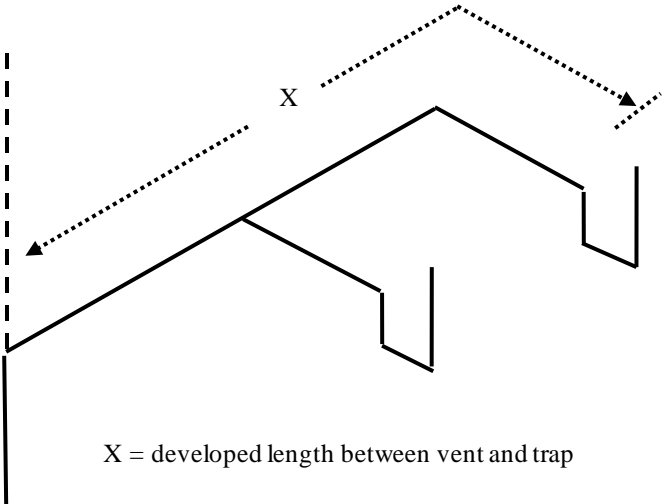

X = developed length between vent and trap

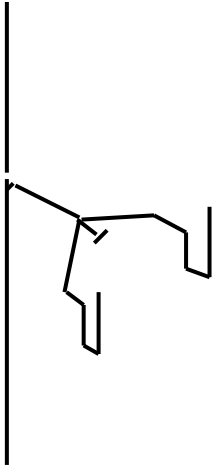

A-82.31 (12) RETURN VENTS.

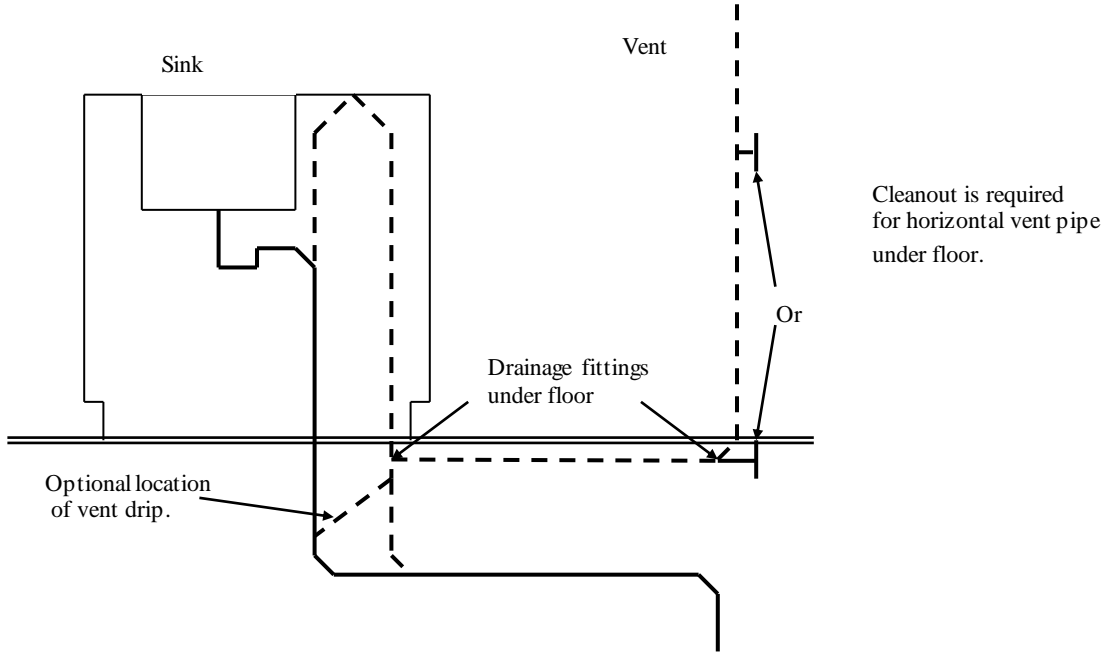

A-82.31 (13) (a) VERTICAL WET VENTS.

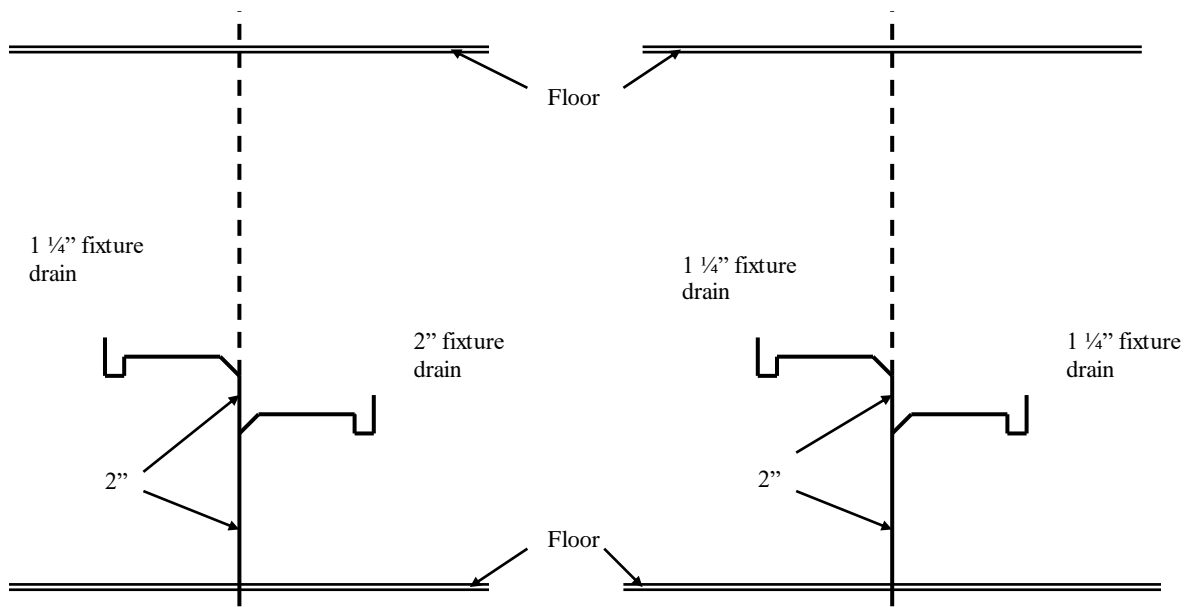

A-82.31 (13)-1. HORIZONTAL WET VENTS.

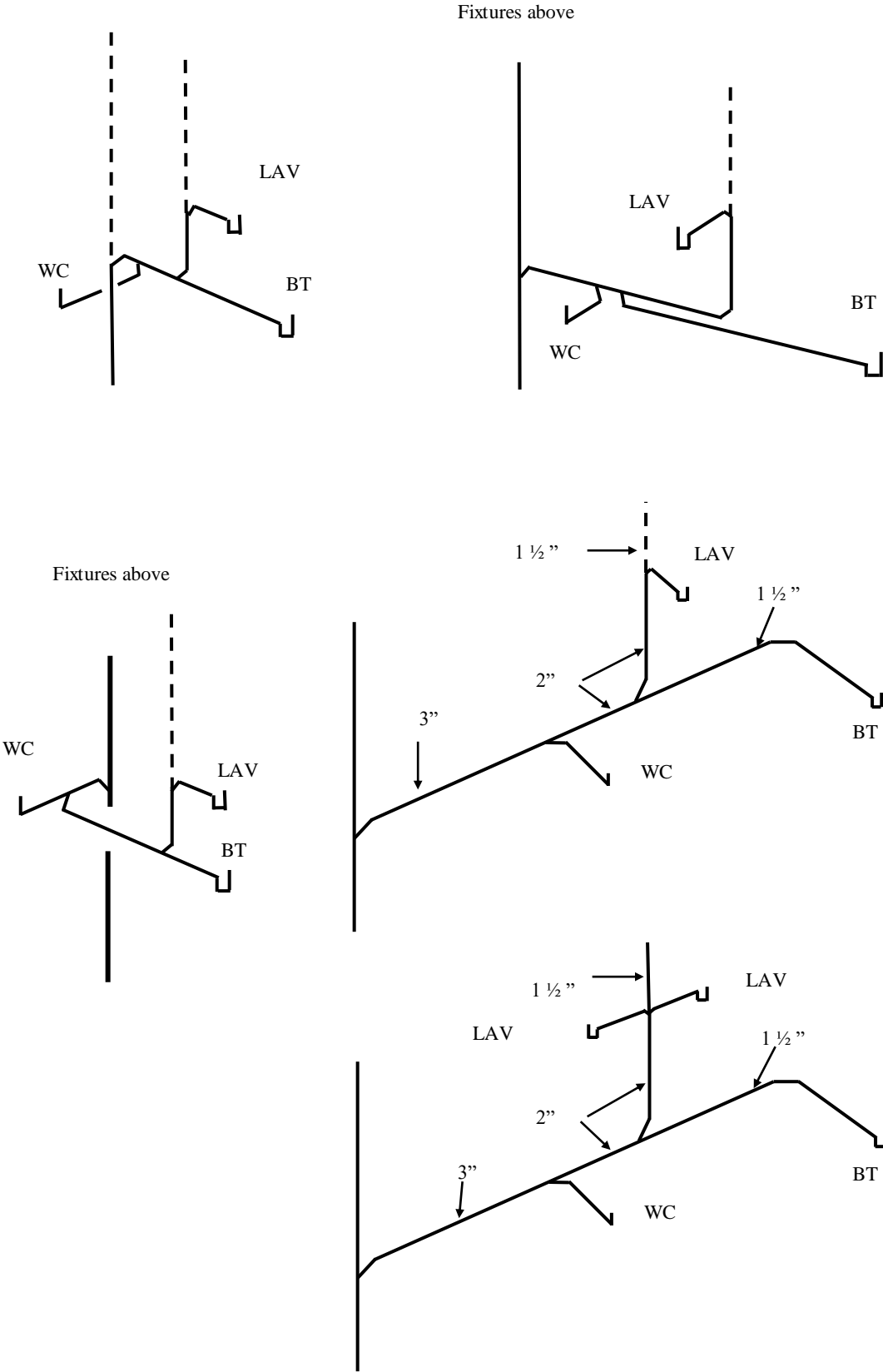

A-82.31 (13)-2. WET VENTING – FLOOR OUTLET FIXTURES.

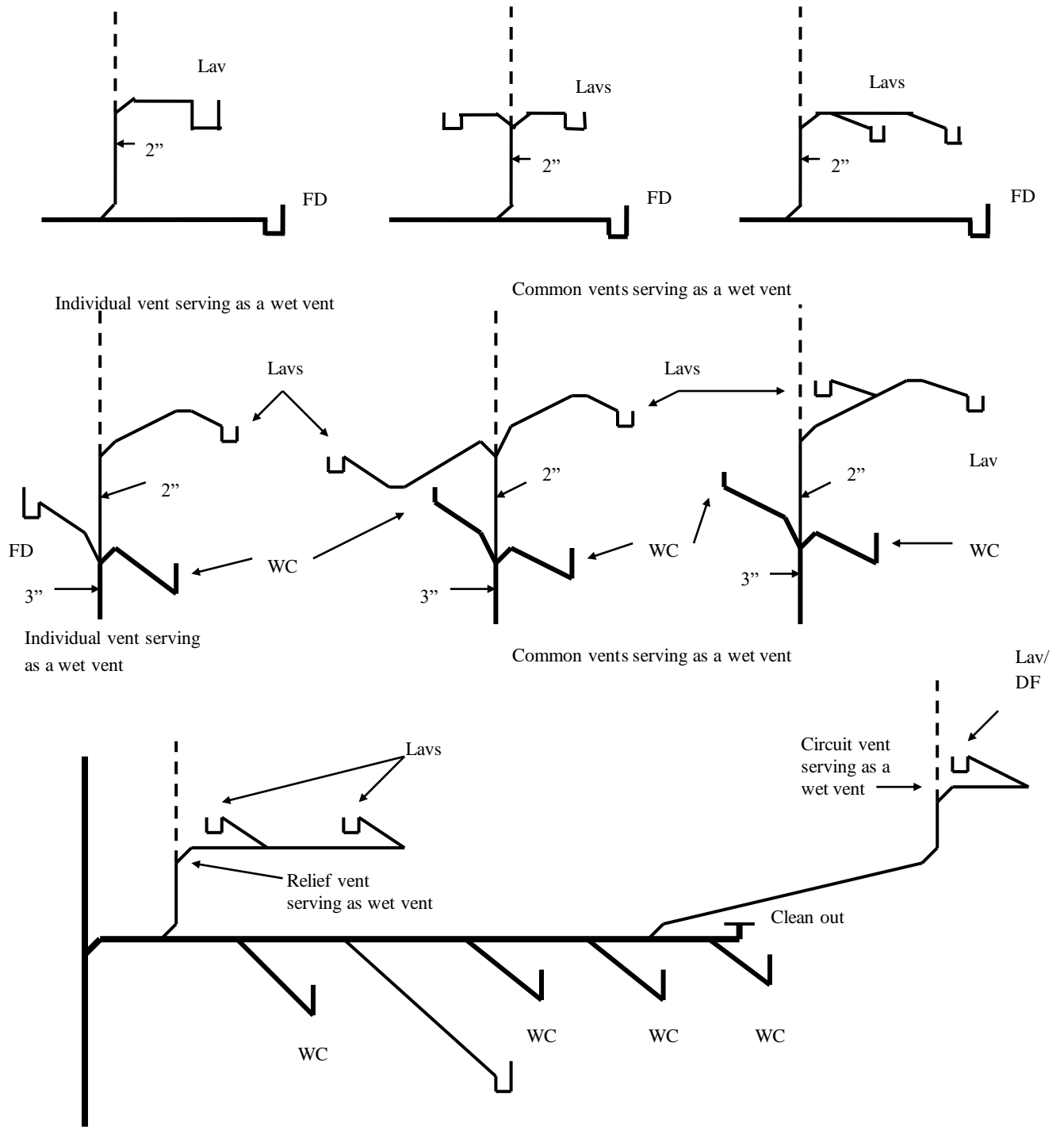

A-82.31 (14) (a) and (b) SIZING VENT STACKS AND STACK VENTS

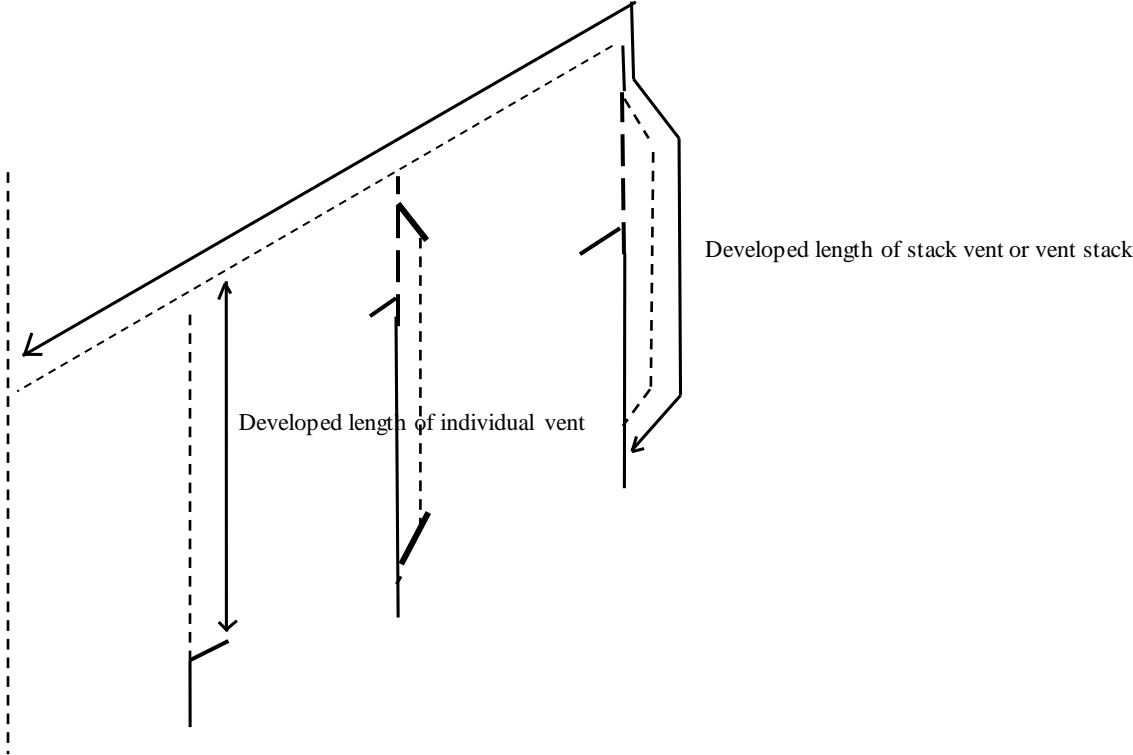

A-82.31 (14) (c) SIZING BRANCH VENTS SERVING A WET VENT.

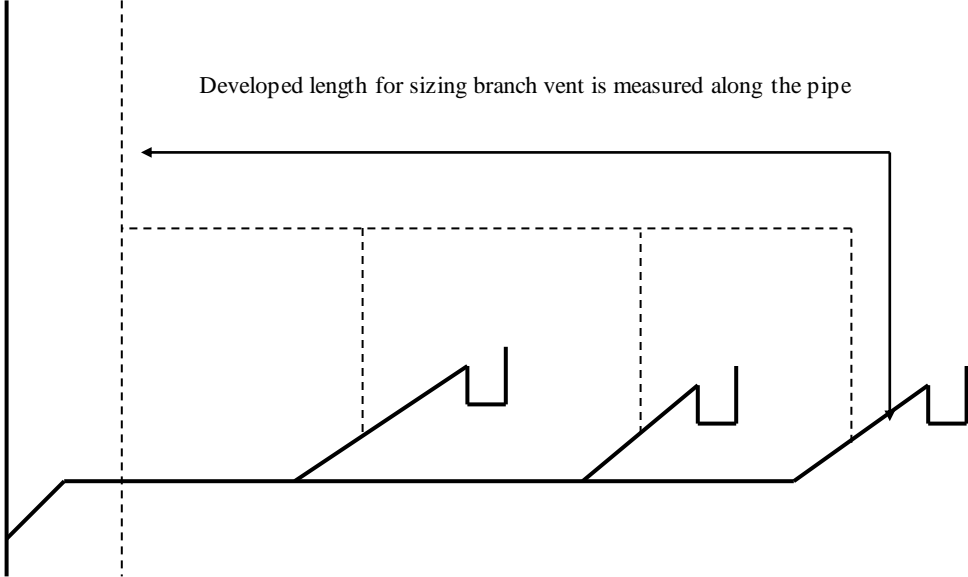

A-82.31 (14) (d) SIZING INDIVIDUAL VENTS.

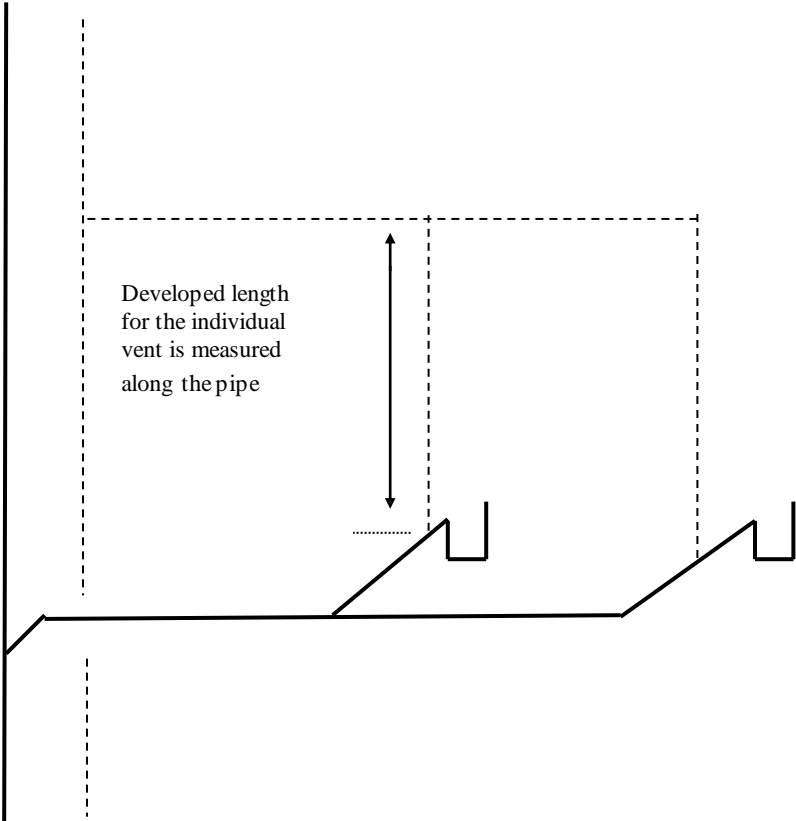
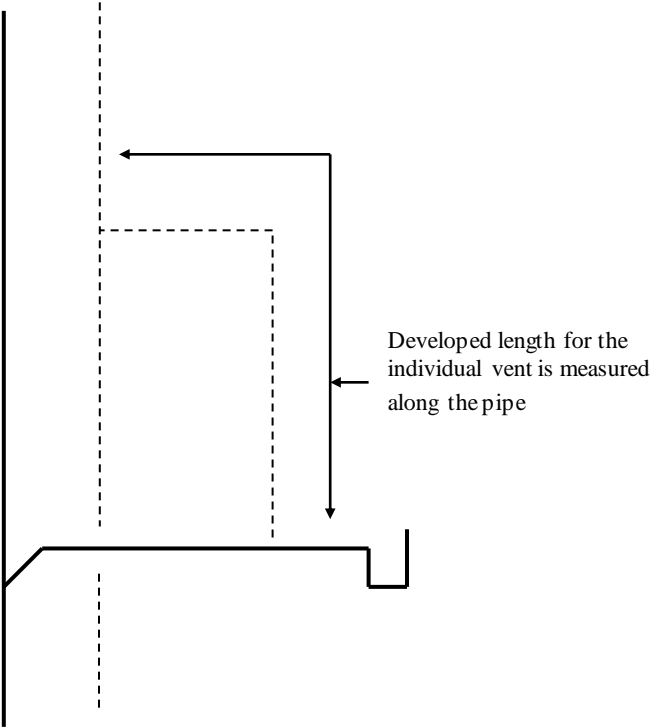

A-82.31 (15) (a) VENT GRADES AND CONNECTIONS.

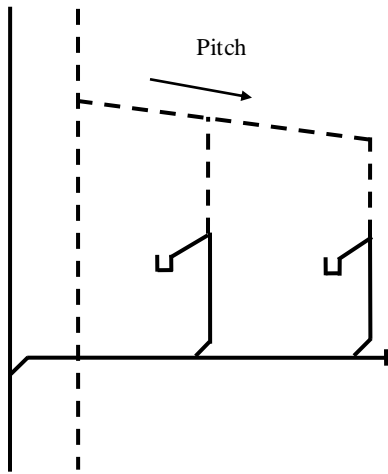

WHEREVER POSSIBLE

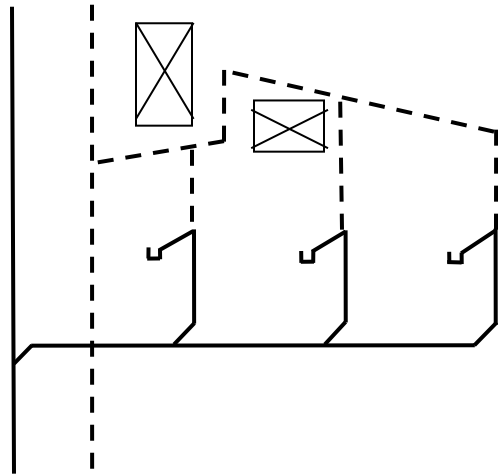

MAYBE ALLOWED WHERE CONDITIONS DICTATE

A-82.31 (15) (b) VENT GRADES AND CONNECTIONS.

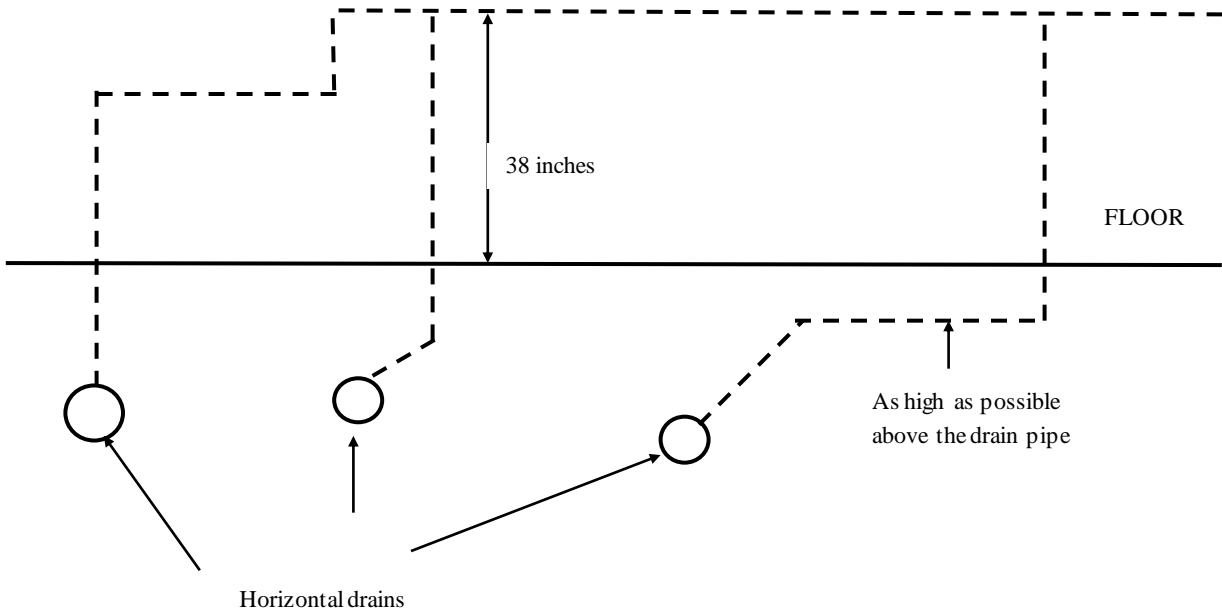

A-82.31 (16) VENT TERMINALS.

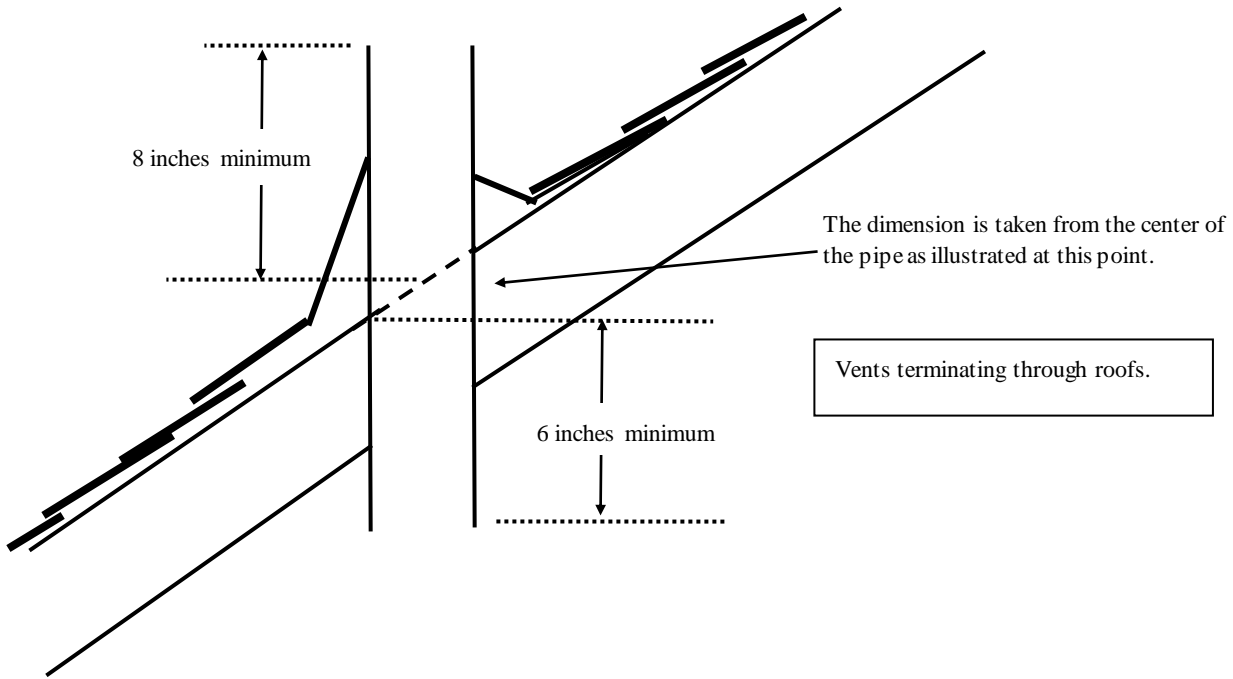

A-82.31 (16) VENT TERMINALS.

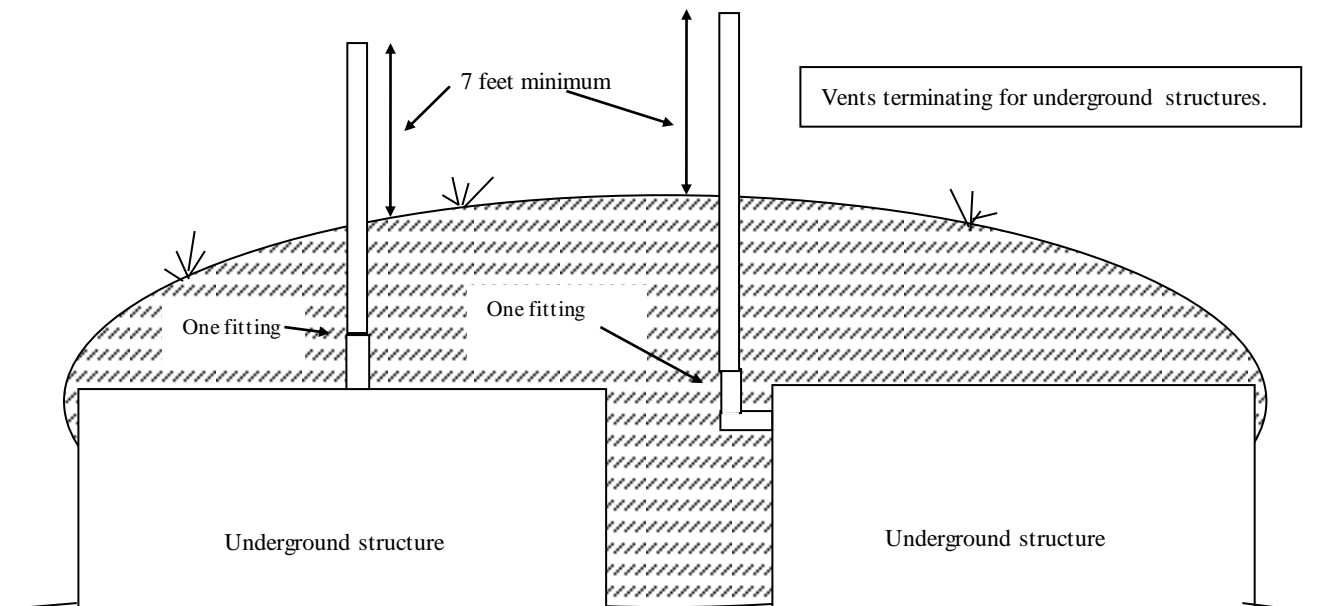
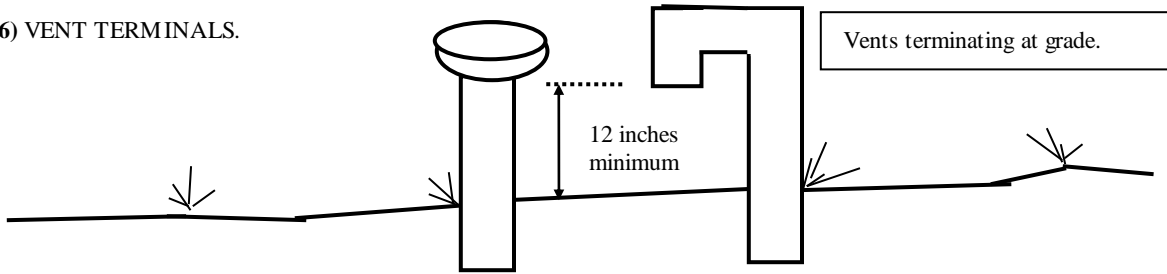

A-82.31 (17) (a) COMBINATION DRAIN AND VENT STACKS.

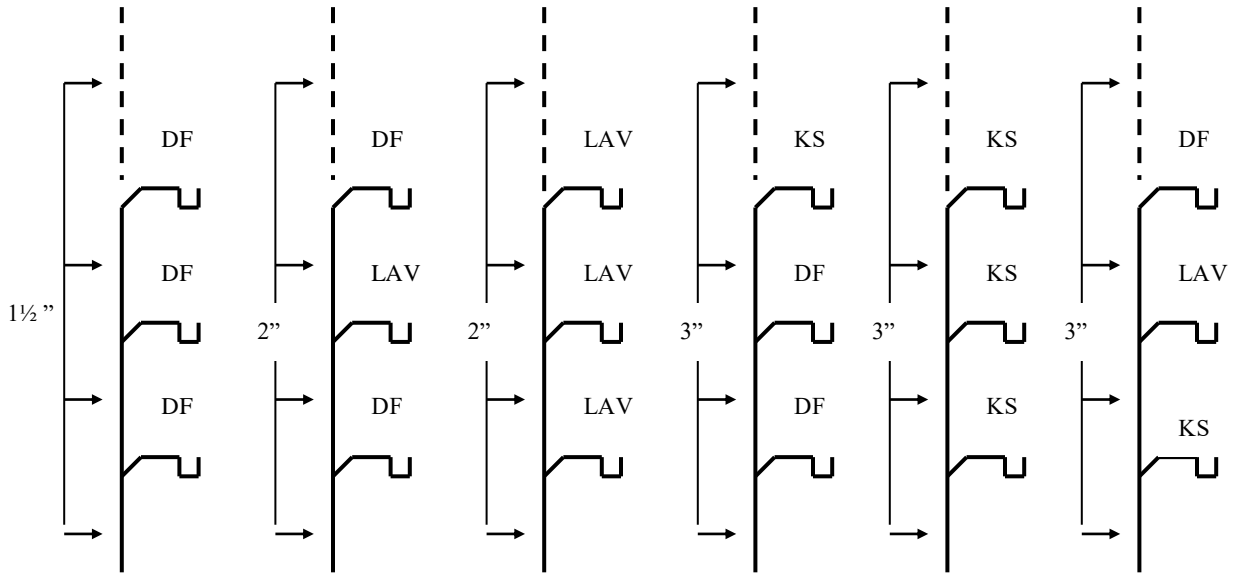

Most restrictive fixture determines stack size

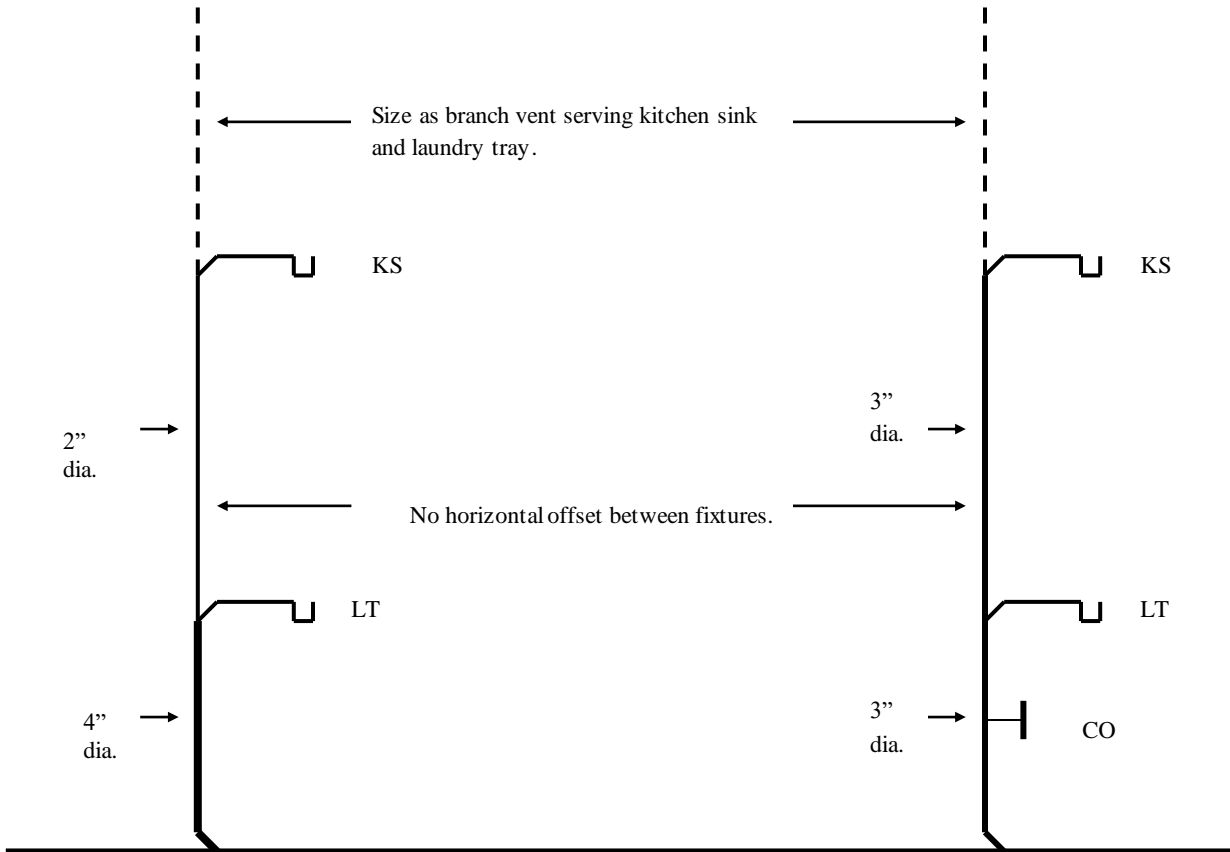

A-82.31 (17) (b) COMBINATION DRAIN AND VENT BUILDING DRAIN.

Stacks must be 1/2 size of building drain, but not less than 2" diameter.

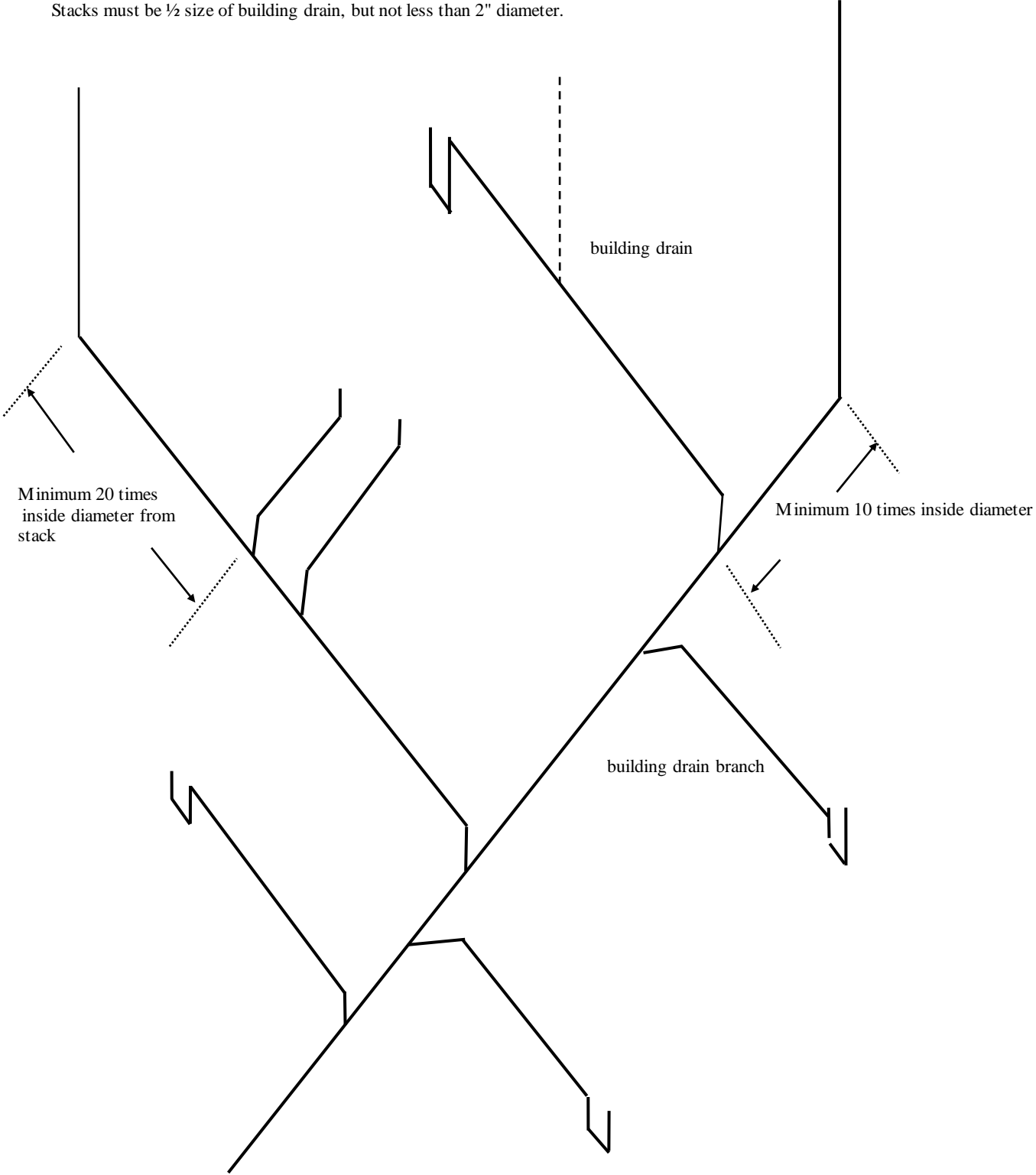

A-82.31 (17) (c) COMBINATION DRAIN AND VENT LABORATORY SINK VENTING.

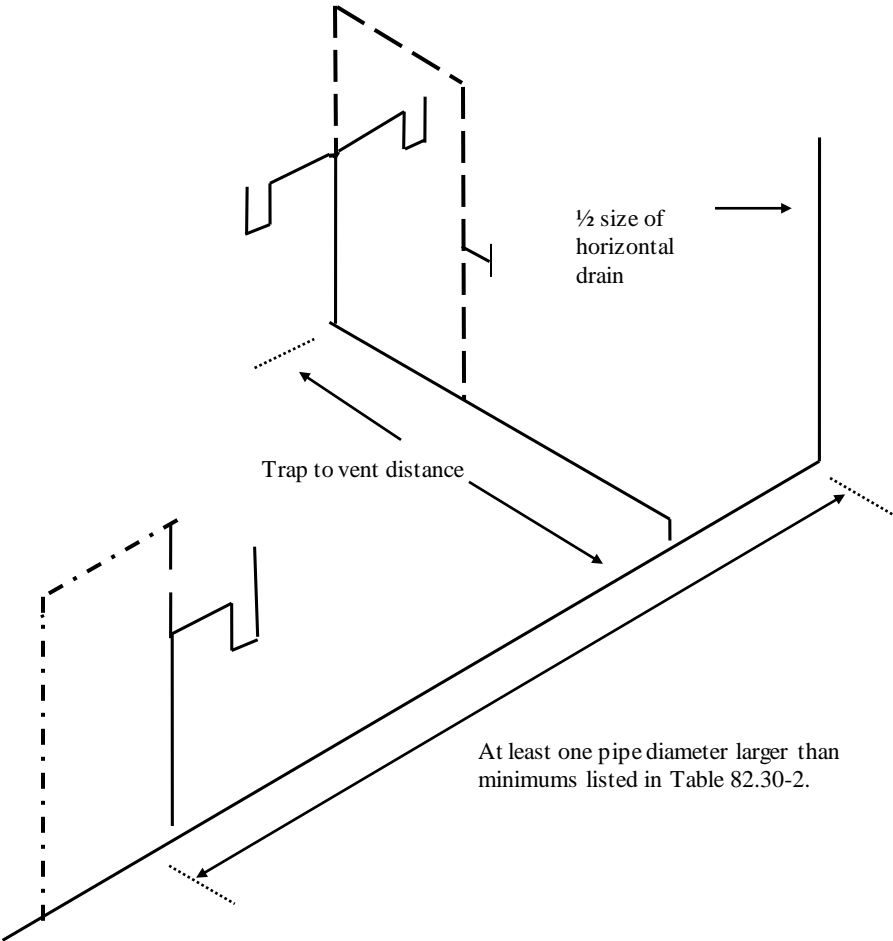

LABORATORY SINK VENT

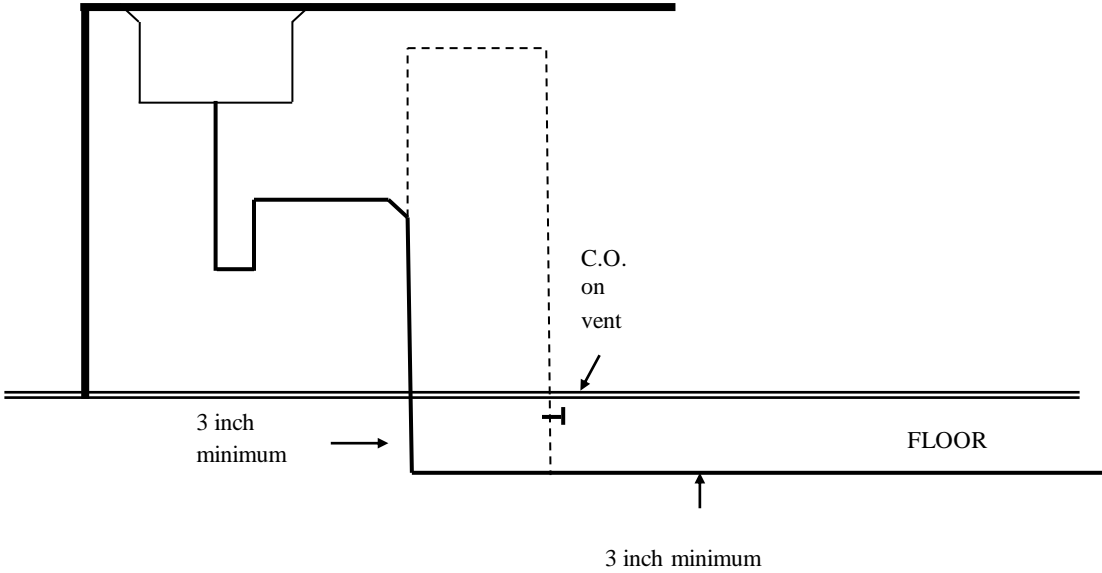

A-82.32 (4) (b) INSTALLATION OF TRAPS.

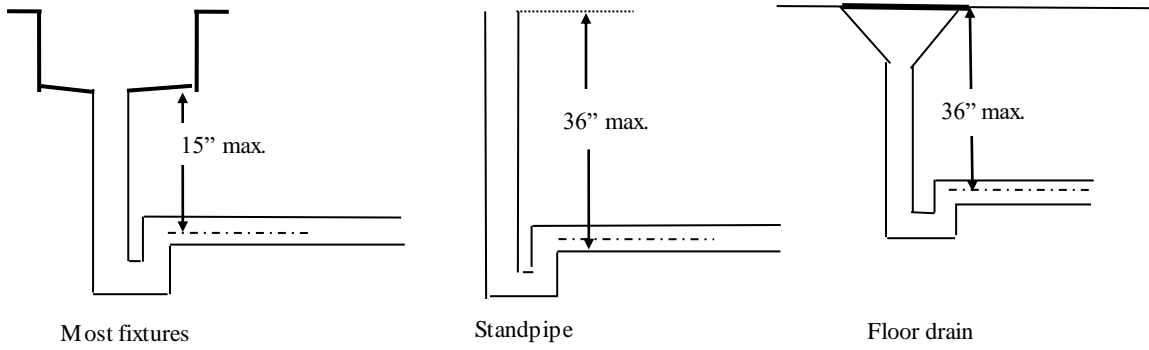

Vertical distance between fixture drain outlet and trap

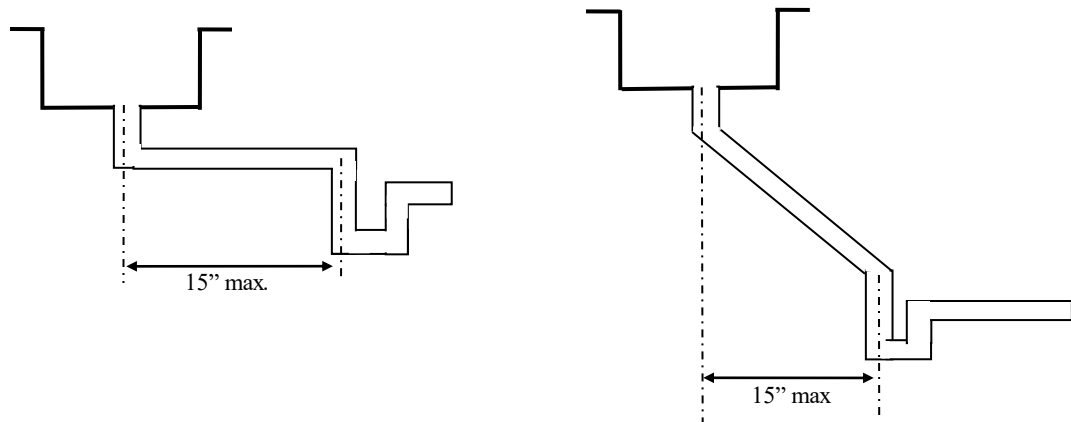
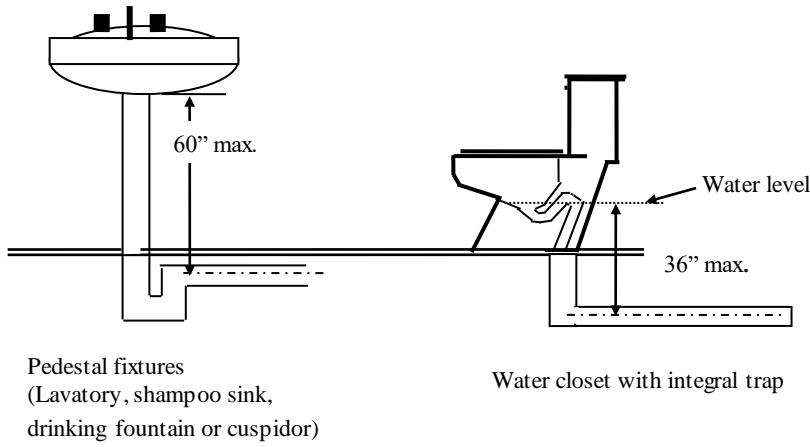

Horizontal distance between fixture drain outlet and trap

(end of document 1)