

C E R T I F I C A T E

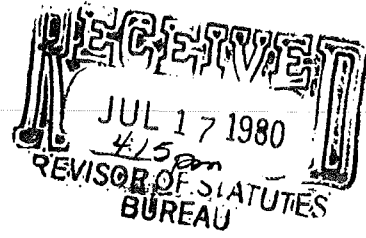

STATE OF WISCONSIN )  
 )  
DEPARTMENT OF TRANSPORTATION )

TO ALL TO WHOM THESE PRESENTS COME, GREETINGS:

I, Lowell B. Jackson, Secretary of the Department of Transportation and custodian of the official records of the Department, do hereby certify that the annexed rules relating to trailer and mobile home classification and standard minimum strength requirements of hitch and coupling, relating to safety chains or cables for trailers and mobile homes and relating to safety chain or cable for full trailers or trailer converter dollies connected by means of a pintle and tow bar eye, were duly approved and adopted by this Department on July 15th, 1980.

I further certify that this copy has been compared by me with the original on file in this Department and that the same is a true copy thereof, and of the whole of such original.



IN TESTIMONY WHEREOF, I have hereunto set my hand and affixed the official seal of the Department at the Hill Farms State Office Building in the city of Madison, this 15th day of July, 1980.

*Lowell B. Jackson*  
\_\_\_\_\_  
LOWELL B. JACKSON, P.E.

Secretary  
Wisconsin Department of Transportation

*Print eff. date 10-1-80*

---

IN THE MATTER OF THE ADOPTION OF A :  
 RULE TO REPEAL MVD 8.10(4)(c); TO :  
 RENUMBER MVD 8.01 TO 8.09, 8.10(1) :  
 TO (3) AND (4)(a) AND (b) AND 8.11 :  
 TO 8.13; TO AMEND CH. MVD 8(TITLE) :  
 AND TRANS 152.01(2), AS RENUMBERED, :  
 TRANS 152.02(4), AS RENUMBERED, :  
 152.10(3)(a) TO (d) AND (4)(TITLE) :  
 AND (4)(b), AS RENUMBERED, AND : ORDER  
 152.12(1) AND (2)(INTRO.), AS RE- : ADOPTING  
 NUMBERED; AND TO CREATE TRANS : RULES  
 152.10(3)(e) AND 152.14, RELATING :  
 TO TRAILER AND MOBILE HOME CLASSI- :  
 FICATION AND STANDARD MINIMUM :  
 STRENGTH REQUIREMENTS OF HITCH AND :  
 COUPLING, RELATING TO SAFETY CHAINS :  
 OR CABLES FOR TRAILERS AND MOBILE :  
 HOMES, AND RELATING TO SAFETY CHAIN :  
 OR CABLE FOR FULL TRAILERS OR :  
 TRAILER CONVERTER DOLLIES CONNECTED :  
 BY MEANS OF A PINTLE AND TOW BAR :  
 EYE. :

---

Analysis Prepared by the Department of Transportation

General summary of the rule. This rule renumbers the current Chapter MVD 8 to TRANS 152 and repeals, adopts and amends rule provisions affecting the current rule text. The renumbering is being done as part of a general restructuring of the Department of Transportation's administrative rules and has been coordinated with the Legislative Council staff and the Revisor of Statutes in accordance with sec. 227.024(1)(e), Wis. Stats. The purpose of the repeals, adoptions and amendments is primarily to further clarify the statutory requirements of sec. 347.47(3), Wis. Stats., concerning the use of safety chains or cables where a vehicle is towing another vehicle or vehicles on a highway.

Subsection MVD 8.10(3) (renumbered TRANS 152.10(3)) is amended to provide a trailer and a mobile home classification system that includes vehicles with a gross weight in excess of 10,000 pounds. This classification system follows the format in the SAE handbook (Society of Automotive Engineers); it is an industry standard.

MVD 8.10(4)(b) (renumbered TRANS 152.10(4)(b)) is also amended to provide for a vehicle classification identical to that to be provided in MVD 8.10(3) (now TRANS 152.10(3)).

Currently subs. MVD 8.12(1) requires two separate lengths of safety chain or of cable on all trailers and mobile homes. That subsection (renumbered TRANS 152.12(1)) is amended to provide three exceptions to the general safety chain or cable requirement. An exception for semitrailers having a fifth wheel and kingpin assembly connection and an exception for a pole or pipe dolly merely restate the statutory provisions of sec. 347.47(3), Wis. Stats. A third exception is also provided. A single length of chain or cable, instead of the required two lengths, may be used between a towing vehicle and a full trailer or between a towing vehicle and a trailer converter dolly connected by a pintle and tow bar eye when all the installation and capacity requirements set forth in TRANS 152.14, which is adopted by this rule-making, are met.

Section TRANS 152.14, an entirely new section, is adopted to provide detailed safety chain and cable requirements for full trailers and trailer converter dollies connected by means of a pintle and tow bar eye. This new section contains definitions, safety chain and cable installation and capacity requirements, and a table showing the published breaking strengths of various types of safety chains and cables. Section TRANS 152.14 follows the Society of Automotive Engineers' recommended practice SAE J697a - Safety Chain of Full Trailers or Converter Dollies.

Authority for rule. Section 347.47(3), Wis. Stats., provides in relevant part as follows:

"Two separate lengths of safety chain, leveling bars or cable shall be required on all trailers and mobile homes; however, the department may authorize use of such other appropriate equipment or methods approved by nationally recognized organizations which recommend safety standards for motor vehicles." (Emphasis added.)

Section 347.47(4), Wis. Stats., provides in relevant part as follows:

"Trailer, semitrailer, and mobile home couplings and the safety chains, leveling bars or cables shall be of such minimum strength, design and type as established by published rule of the department."

Fiscal estimate. This rule change will have no apparent fiscal impact upon either state or local units of government. The repeals, amendments and adoptions relate directly to the

operation of motor carriers operating in the private sector of the economy. Enforcement costs should not increase as a result of the rule change since the change clarifies existing statutory and rule provisions and follows what is already a widely accepted safety standard in the trucking industry.

The analysis has been prepared by Philip Peterson, Assistant General Counsel, Department of Transportation (608-266-8810).

---

Pursuant to authority vested in the Department of Transportation by secs. 110.06, 227.014 and 347.47(3) and (4), Wis. Stats., the Department of Transportation repeals, renumbers, amends and adopts rules interpreting sec. 347.47(3), Wis. Stats., as follows:

RULE TEXT

SECTION 1. Chapter MVD 8(title) of the Wisconsin Administrative Code is renumbered to read:

TRANS 152(title).

SECTION 2. Sections MVD 8.01 through MVD 8.13 are renumbered to read:

TRANS 152.01 through TRANS 152.13.

SECTION 3. Section TRANS 152.01(2), as renumbered, of the Wisconsin Administrative Code, is amended to read:

TRANS 152.01(2) Every truck tractor and truck when used for towing other vehicles equipped with vacuum brakes, shall have, in addition to the single control required by section MVD 8-06 TRANS 152.06 to operate all brakes of the combination, a second manual control device which can be used to operate the brakes on the towed vehicles in emergencies. Such second

control shall be independent of other controls, unless the braking system be so arranged that failure of the pressure on which the second control depends will cause the towed vehicle brakes to be applied automatically. The second control is not required by this rule to provide modulated or graduated braking.

SECTION 4. Subsection TRANS 152.02(4), as renumbered, of the Wisconsin Administrative Code is amended to read:

TRANS 152.02(4)(a) Brake hose shall be so constructed as to insure adequate and reliable functioning and shall conform to the appropriate specification set forth in the SAE Standards for "Hydraulic Brake Hose", "Air Brake Hose", or "Vacuum Brake Hose". ~~(See 1968 SAE Handbook, pages 260-264.)~~ "Hydraulic Brake Hose Assemblies for use with Non-Petroleum Base Hydraulic Fluids," SAE J1401a; "Automotive Air Brake Hose and Hose Assemblies," J1402c; or "Vacuum Brake Hose," J1403a. (See 1980 SAE Handbook.)

(b) The above referred to SAE Standards are on file in the offices of the Department of Transportation, the Secretary of State and the Revisor of Statutes, and may be obtained from the Society of Automotive Engineers, Inc., 400 Commonwealth Drive, Warrendale, Pennsylvania 15096.

SECTION 5. Paragraphs TRANS 152.10(3)(a) to (d), as renumbered, of the Wisconsin Administrative Code, are amended to read:

TRANS 152.10(3) (a) Class A 1-All vehicles whose gross weight does not exceed 2000 lbs.

(b) Class B 2-All vehicles in excess of 2000 lbs. gross weight but not exceeding 3500 lbs. gross weight.

(c) Class C 3-All vehicles in excess of 3500 lbs. gross weight and not exceeding 5000 lbs. gross weight.

(d) Class D 4-All vehicles with gross weight in excess of 5000 lbs. but not to exceed 10,000 lbs.

SECTION 6. Paragraph TRANS 152.10(3) (e) of the Wisconsin Administrative Code is adopted to read:

TRANS 152.10(3) (e) Class 5-All vehicles with a gross weight in excess of 10,000 lbs.

SECTION 7. Subsection TRANS 152.10(4) (title), as renumbered, of the Wisconsin Administrative Code, is amended to read:

TRANS 152.10(4) (title) STRENGTH RATINGS FOR TRAILER AND MOBILE HOME COUPLINGS AND FOR CLASS 5 VEHICLE HITCHES.

SECTION 8. Paragraph TRANS 152.10(4) (b), as renumbered, of the Wisconsin Administrative Code, is amended to read:

TRANS 152.10(4) (b) Minimum strength ratings for the coupling used in conjunction with specific classes of trailers and mobile homes and for the hitch used in conjunction with Class 5 vehicles:

=====

Vehicle Classification      Minimum Breaking Point Requirements of Coupling  
and of Class 5 Vehicle Hitch

---

Class A 1      Longitudinal tension..... 6,000 lbs.  
 Longitudinal compression..... 6,000 lbs.  
 Transverse thrust..... 2,000 lbs.  
 Vertical tension..... 2,500 lbs.  
 Vertical compression..... 2,500 lbs.

Class B 2      Longitudinal tension.....10,500 lbs.  
 Longitudinal compression.....10,500 lbs.  
 Transverse thrust..... 3,000 lbs.  
 Vertical tension..... 4,500 lbs.  
 Vertical compression..... 4,500 lbs.

Class C 3      Longitudinal tension.....15,000 lbs.  
 Longitudinal compression.....15,000 lbs.  
 Transverse thrust..... 4,000 lbs.  
 Vertical tension..... 7,000 lbs.  
 Vertical compression..... 7,000 lbs.

Class D 4      Longitudinal tension-gross ~~load~~ weight of  
 trailer-type vehicle in pounds x 3.  
 Longitudinal compression-gross ~~load~~ weight of  
 trailer-type vehicle in pounds x 3.  
 Transverse thrust-gross ~~load~~ weight of  
 trailer-type vehicle in pounds x 1.  
 Vertical tension-gross ~~load~~ weight of  
 trailer-type vehicle in pounds x 1.3.  
 Vertical compression-gross ~~load~~ weight of  
 trailer-type vehicle in pounds x 1.3.

Class 5      Strength rating of hitch and coupling for  
 trailers over 10,000 lbs.-Each coupling system,  
 other than safety chain or cable, shall have a  
 minimum longitudinal strength, in both tension  
 and compression, no less than 130% of the gross  
 weight towed by the coupling system. The coup-  
 ling system shall include not only coupling  
 devices such as tow bars, pintles, and tow bar  
 eyes, but also all the members, means and  
 attachments used to fasten or to secure the  
 coupling device to the motor vehicle.

SECTION 9. Paragraph TRANS 152.10(4)(c), as renumbered, of  
 the Wisconsin Administrative Code, is repealed.

SECTION 10. Subsection TRANS 152.12(1), as renumbered, of the Wisconsin Administrative Code, is amended to read:

TRANS 152.12(1) NUMBER OF LENGTHS OF CHAIN REQUIRED. Two separate lengths of safety chain or cable shall be required on all trailers and mobile homes. This requirement shall not apply to semitrailers having a connecting device composed of a fifth wheel and kingpin assembly (s. 347.47(3), Wis. Stats.), to a pole or pipe dolly (s. 347.47(3), Wis. Stats.), nor between towing vehicles and full trailers or trailer converter dollies when the towing vehicle is connected to the towed vehicle by means of a pintle and tow bar eye and all the installation and capacity requirements of s. TRANS 152.14, Wis. Administrative Code, are met.

SECTION 11. Subsection TRANS 152.12(2)(intro.), as renumbered, of the Wisconsin Administrative Code, is amended to read:

TRANS 152.12(2)(intro.) STRENGTH RATINGS FOR SAFETY CHAINS OR CABLES. The strength rating for each length of safety chain or cable used in conjunction with trailers and mobile homes as ~~classified in section MVD 8-10(3)~~ shall be as follows:

SECTION 12. Section TRANS 152.14 of the Wisconsin Administrative Code, is adopted to read:

TRANS 152.14 Safety chain or cable for full trailers or trailer converter dollies connected by means of a pintle and tow bar eye.

(1) DEFINITIONS. (a) Full trailer means a truck trailer whose weight is carried entirely on its own wheels.



(b) Trailer converter dolly means a truck trailer with one or more axles equipped with a fifth wheel, a drawbar and other parts necessary to convert a semitrailer to a full trailer.

(c) Truck trailer means a vehicle without auxiliary motive power designed to be drawn by a motor truck or truck tractor, but does not include a mobile home.

(d) Safety chain means the chain or cable from the front of a full trailer or a trailer converter dolly to the rear of the towing vehicle for the purpose of retaining the connection between the towing and the towed vehicles and of controlling the direction of travel of the towed vehicle in the event of failure of the drawbar or the connection on the rear of the towing vehicle.

(e) Pintle means a connection meeting the requirements of SAE J849b. See Fig. 1 following this section.

(f) Tow bar eye means a device attached to the tow bar of the full trailer or trailer converter dolly meeting the requirements of SAE J847. See Fig. 2 following this section.

(2) USE OF A SINGLE LENGTH OF SAFETY CHAIN OR CABLE. A single length of chain or of cable or a bridle arrangement of a single chain or cable may be used between a towing vehicle and a full trailer or between a towing vehicle and a trailer converter dolly when the towing vehicle is connected to the towed vehicle by means of a pintle and tow bar eye if all the installation and capacity requirements of this section are met.

(3) INSTALLATION. (a) The safety chain shall be attached by suitable means to the frame of the full trailer or of the trailer converter dolly to which full trailer or trailer converter dolly a hinged drawbar is attached and to the frame of the towing vehicle. Trailer converter dollies with solid tongues and without hinged tow bars may have the safety chain attached to the solid tongue. The connection or coupling device shall not be used as a means of attaching the safety chain to the towing vehicle frame. The safety chain shall be attached to both the towing and the towed vehicles in such a manner so as to be capable of developing the full capacity of the chain into the frame members of the towing and towed vehicles. The safety chain shall be so installed as to support the drawbar and prevent it from dropping to the ground in the event of failure of the drawbar or connection on the rear of the towing vehicle. The safety chain shall be attached and installed so as to keep the trailer in a straight line back of the towing vehicle insofar as practicable in event of failure of the drawbar, connection or coupling device. The safety chain shall have no more slack, when in use, than is necessary to permit proper turning of the vehicle.

(b) Two safety chains or two cables, when used, may be attached to the full trailer front axle or to the trailer converter dolly axle near the wheels in lieu of the requirements set forth in paragraph (a) of this subsection. The means of

attachment shall be capable of developing the full capacity of the safety chains or cables into the axle and shall meet all the requirements set forth in s. TRANS 152.12(3), Wisconsin Administrative Code.

(4) CAPACITY. (a) The safety chain capacity shall be equal to the gross weight of the vehicle or vehicles being towed. For the purpose of this section, the safety chain capacity shall be the published breaking strength. The safety cable capacity shall be the published breaking strength. In the absence of a published breaking strength, the safety chain or cable capacity shall be the ultimate strength by actual test performed by the manufacturer.

(b) When two chains or two cables are used, each chain or cable shall have a capacity equal to the gross vehicle weight of the vehicle or vehicles being towed.

(c) Breaking strengths are given as follows:

Type	Published Breaking Strength, lb.
Alloy Steel Chain, in.	
1/2	32,500
5/8	50,000
3/4	69,500
Wire Rope Fed Spec RR-W-410a Type 1, Class 2	
6 x 19 Plow Steel with Steel Core, in.	
1/2	23,000
9/16	29,000
5/8	36,000
3/4	51,200
7/8	69,200

Roebling Royal Blue Wire Rope 6 x 19, in.	
1/2	26,600
9/16	33,600
5/8	41,200
3/4	59,800
7/8	79,600

---

(5) The following figures are Society of Automotive Engineers' (SAE) recommended practices found in the 1980 SAE Handbook. These recommended practices are on file in the offices of the Department of Transportation, the Secretary of State and the Revisor of Statutes, or may be obtained from the Society of Automotive Engineers, Inc., 400 Commonwealth Drive, Warrendale, Pennsylvania 15096.

(End)

FIGURE 1

### CONNECTION AND ACCESSORY LOCATIONS FOR TOWING DOUBLES TRAILERS AND MULTI-AXLE TRAILERS—SAE J849b

SAE Recommended Practice

Report of Transportation and Maintenance and Truck and Bus Technical Committees approved June 1963 and last revised January 1970.

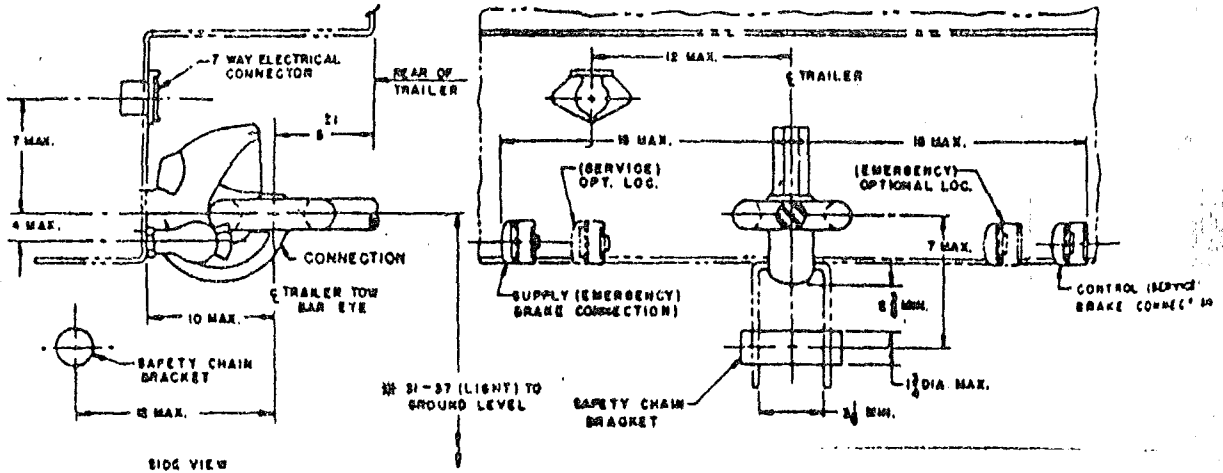

\* FOR TRUCK INSTALLATION, THIS DIMENSION TO BE 27-33.

This SAE Recommended Practice applies to all commercial trailers exceeding 40,000 lb gvw, except drop frame types.

Connection and mounting structure must withstand a tow bar pull equivalent to 115% of the gvw of the towed trailer without residual deformation to mounting or trailer structure.

NOTE: All dimensions given in inches.

FIGURE 1 (CONTINUED)

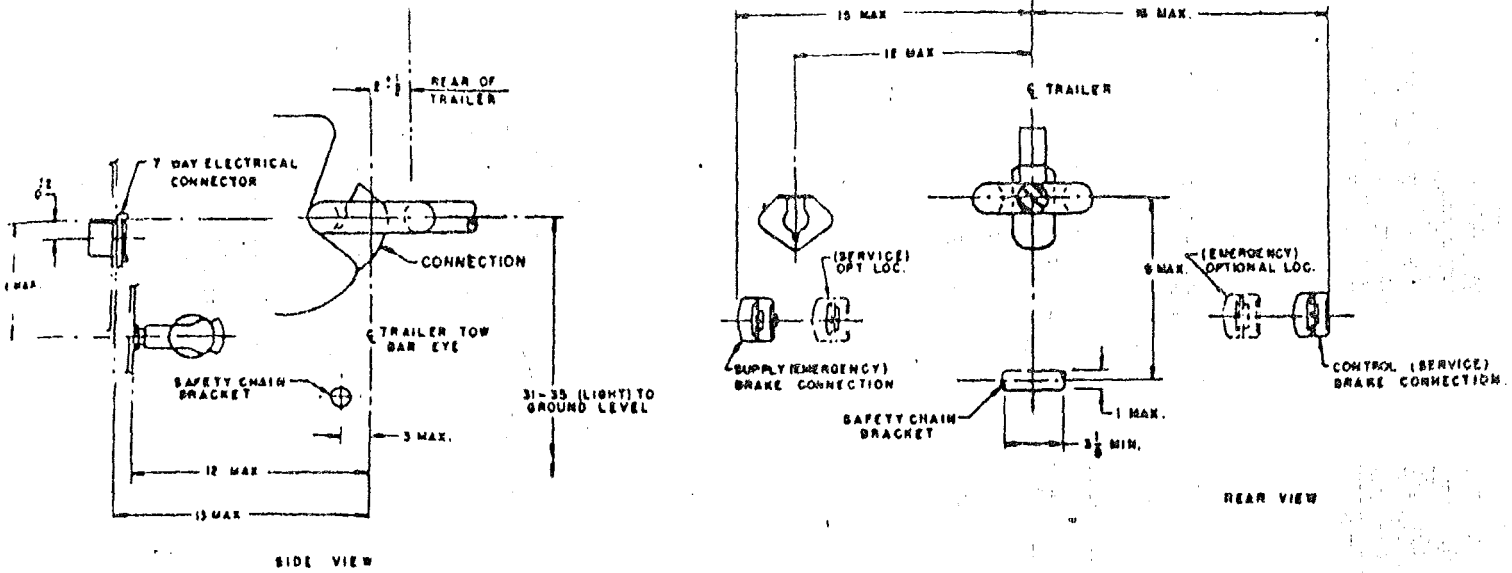

This SAE Recommended Practice applies to all commercial single axle doubles trailers to a maximum gvw of 40,000 lb, except drop frame and car haul types.

Connection and mounting structure must withstand a tow bar pull equivalent to 115% of the gvw of the towed trailer without residual deformation to mounting or trailer structure.

NOTE: All dimensions given in inches.

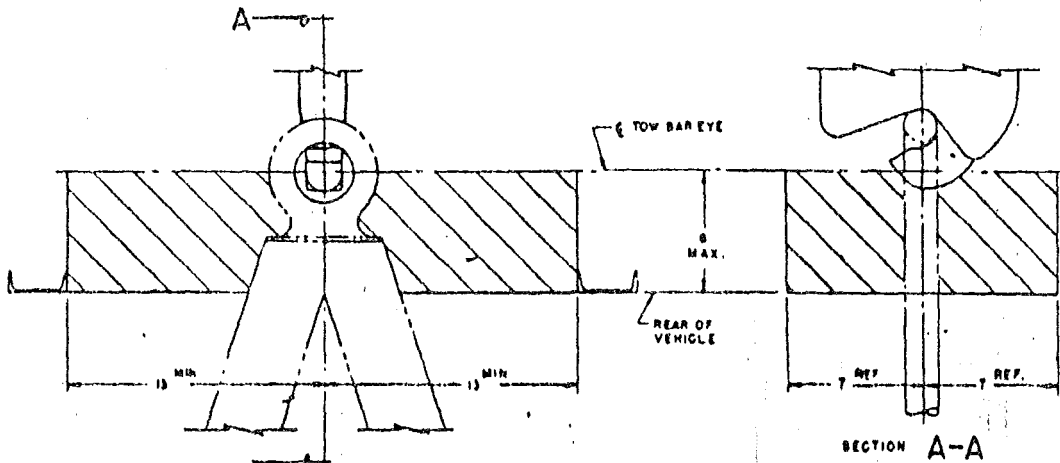

Clearance space shown must extend 7 in. above and 7 in. below the horizontal centerline of the drawbar eye as shown in Section A-A.

NOTE: All dimensions given in inches.

FIGURE 2

**FULL TRAILER  
TOW BAR EYE—SAE J847**

**SAE Recommended Practice**

Report of Transportation and Maintenance and Truck and Bus Technical Committees approved June 1963.

This SAE Recommended Practice for commercial trailer tow bar eye applies to trailer converter and full trailer.

NOTE: Trailer tow bar eye, and its attachment to towing vehicle, must withstand a 60,000 lb tow bar pull without residual deformation.

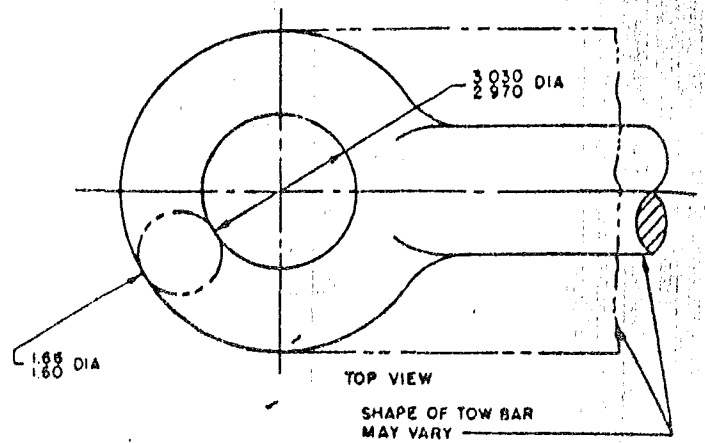

(End)

The renumbering, repeals, adoptions and amendments contained in this rule shall take effect upon publication as provided in sec. 227.026(1)(intro.), Wis. Stats.

Dated at Madison, Wisconsin, this  
15<sup>th</sup> day of July, 1980.

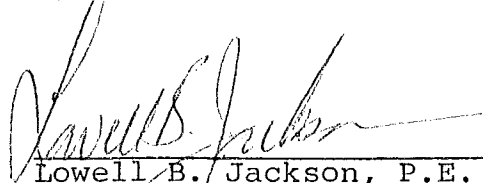

---

Lowell B. Jackson, P.E.  
Secretary

Wisconsin Department of Transportation



# CORRESPONDENCE/MEMORANDUM

STATE OF WISCONSIN

Date: July 14, 1980

File Ref:

To: Orlan L. Prestegard  
Revisor of Statutes  
Room 411 West, State Capitol

From: Philip Peterson, Assistant General Counsel  
Office of General Counsel  
Wisconsin Department of Transportation



Subject: Clearinghouse Rule 80-83

Attached for filing, please find a certified copy of CR 80-83, an administrative rule relating to trailer and mobile home classification and standard minimum strength requirements of hitch and coupling, to safety chains or cables for trailers and mobile homes, and to safety chain or cable for full trailers or trailer converter dollies connected by means of a pintle and tow bar eye.

This rule repeals MVD 8.10(4)(c); renumbers MVD 8.01 to 8.09, 8.10(1) to (3) and (4)(a) to (b) and 8.11 to 8.13; amends Ch. MVD 8 (title) and TRANS 152.01(2), as renumbered, TRANS 152.02(4) as renumbered, 152.10(3)(a) to (d) and (4)(title) and (4)(b), as renumbered, and 152.12(1) and (2)(intro.), as renumbered; and creates TRANS 152.10(3)(e) and 152.14.

An additional copy of CR 80-83, not certified, is attached to be used for printer's copy.

PP:ck  
Attachment  
cc: William Harvey  
Michael Moschkau  
Carl Zutz