

E 2 to 6, PSC 114

CERTIFICATE

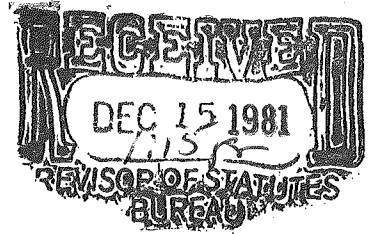

STATE OF WISCONSIN)
) ss.
PUBLIC SERVICE COMMISSION)

TO ALL WHOM THESE PRESENTS SHALL COME, GREETINGS:

I, Jacqueline K. Reynolds, Secretary of the Public Service Commission of Wisconsin, and custodian of the official records of said commission, do hereby certify that the annexed order creating Wis. Adm. Code ch. PSC 114 was duly approved and adopted by this commission on December 1, 1981.

I further certify that said copy has been compared by me with the original on file in this commission and that the same is a true copy thereof, and of the whole of such original.

IN TESTIMONY WHEREOF, I have hereunto set my hand and affixed the official seal of the commission at the Hill Farms State Office Building, in the City of Madison this 1st day of December 1981.

Jacqueline K. Reynolds
Jacqueline K. Reynolds
Secretary to the Commission
PUBLIC SERVICE COMMISSION OF WISCONSIN

DATE MAILED
DEC 2 1981

BEFORE THE

PUBLIC SERVICE COMMISSION OF WISCONSIN

COMPARED WITH AND CERTIFIED BY ME
TO BE A FULL, TRUE AND CORRECT COPY
OF THE ORIGINAL ON FILE IN MY OFFICE.

DEC 1 1981
Jacqueline K. Reynolds
Secretary to the Commission
Public Service Commission of Wisconsin

In the Matter of Proposed Repeal of)
Chapters E2, E4 and E6, Wis. Adm. Code)
(Which Comprise Volume 1, Wisconsin)
State Electrical Code), and Repeal and)
Recreation of Chapter PSC 114, Wis.)
Adm. Code, as Wisconsin State Electrical)
Code, Volume 1)

2-U-5058.6



ORDER OF THE PUBLIC SERVICE COMMISSION
ADOPTING, REPEALING AND AMENDING RULES

Relating to rules concerning electric safety--Repeal and
Recreation of Volume 1 of the Wisconsin State Electrical Code.

Analysis prepared by the Public Service Commission of
Wisconsin.

On June 25, 1981, the Public Service Commission issued
a notice of hearing on revisions to volume 1 of the State
Electrical Code. Volume 1, Wisconsin State Electrical Code,
has been based on the National Electrical Safety Code (American
National Standards Institute C2). In 1979 the Commission adopted
the 1977 edition of the code, with certain changes, deletions
and additions.

The 1981 edition of the National Electrical Safety Code
has now been issued, and the proposed PSC rules contain corres-
ponding revisions. Volume 1 of the Wisconsin State Electrical
Code is presently found in Chapters E2, E4 and E6, Wis. Adm. Code.
The Commission now proposes to repeal these chapters and recreate
ch. PSC 114, Wis. Adm. Code to be known as Vol. 1, Wisconsin State
Electrical Code. The rules in ch. PSC 114 will deal with safety

requirements for the installation and maintenance of electrical facilities.

STATUTORY AUTHORITY

Pursuant to authority vested in the Public Service Commission of Wisconsin by secs. 196.47 and 227.014(2)(a), Stats., the commission repeals and creates rules as follows:

Chapters E2, E4, and E6, Wis. Adm. Code (Wisconsin Electrical Code, Volume 1) and ch. PSC 114, Wis. Adm. Code, are repealed.

Chapter PSC 114, Wis. Adm. Code is repealed and recreated as contained in the appendix.

These rules will take effect on the first day of the month following publication in the Wisconsin Administrative Register, as provided in sec. 227.026, Stats.

Dated at Madison, Wisconsin,

December 1, 1981

By the Commission.

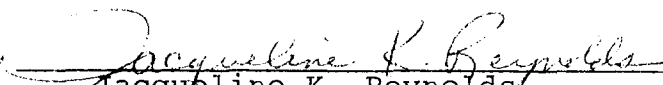
Jacqueline K. Reynolds
Secretary to the Commission

CHAPTER PSC 114
WISCONSIN STATE ELECTRICAL CODE, VOLUME 1

PSC 114.01 GENERAL INFORMATION. (1) ADMINISTRATIVE AUTHORITIES. The Wisconsin State Electrical Code is issued and administered by the public service commission and the department of industry, labor and human relations as part of the Wisconsin Administrative Code. The public service commission has responsibility for issuance and administration of Volume 1 as found in this chapter. The department of industry, labor and human relations has responsibility for issuance and administration of Volume 2 which is found in chapter ILHR 16, Wis. Adm. Code.

(2) AVAILABILITY OF STATE ELECTRICAL CODE. The public service commission has adopted the National Electrical Safety Code (NESC-1981) with certain deletions, changes and additions which are found in Volume 1, Wisconsin State Electrical Code. Copies of the NESC-1981 may be purchased from the Institute of Electrical and Electronics Engineers, Inc., 345 East 47th Street, New York, NY 10017, telephone 212/644-7960; or the American National Standards Institute, 1430 Broadway, New York, NY 10018, telephone 212/354-3300. Copies of Volume 1, Wisconsin State Electrical Code, may be ordered from the Wisconsin Department of Administration, Document Sales, 202 S. Thornton Avenue, Madison, WI 53702, telephone 608/266-3358.

Note: The department of industry, labor and human relations has adopted the National Electrical Code with certain deletions, changes and additions which are found in Volume 2, Wisconsin State Electrical Code. Copies of Volume 2, Wisconsin State Electrical Code, may be ordered from the Wisconsin Department of Administration, Document Sales, 202 S. Thornton Avenue, Madison, WI 53702. See chapter ILHR 16, Wis. Adm. Code, for availability information for the National Electrical Code.

PSC 114.02 PURPOSE AND SCOPE. (1) PURPOSE. The purpose of this chapter is the practical safeguarding of persons during the installation, operation or maintenance of electric supply and communication lines and their associated equipment. The chapter contains minimum provisions considered necessary for the safety of employees and the public and is not intended as a design specification or an instruction manual.

(2) SCOPE. (a) This chapter covers supply and communication lines, equipment, and associated work practices employed by an electric supply, communication, railway, or similar utility in the exercise of its function as a utility. In addition, s. PSC 114-234A prohibits the location of a dwelling occupancy by any party under a transmission line and paragraph PSC 114-234C8 fixes minimum clearance requirements for the construction of a well by any party near open electric supply conductors. This chapter has also been adopted by the department of industry, labor and human relations as part of Volume 2, Wisconsin State Electrical Code, for application to installations over 600 volts of parties other than utilities.

(b) This chapter does not cover installations in mines, ships, railway rolling equipment, aircraft or automotive equipment, or utilization wiring except as covered in Parts 1 and 3, NESC-1981.

PSC 114.03 AUTHORITY AND STATUTORY REFERENCES.

(1) STATUTORY AUTHORITY. Volume 1, Wisconsin State Electrical Code, constitutes a general order of the public service commission authorized by s. 227.014 and 196.74, Stats.

(2) STATUTORY ENFORCEMENT. (a) Compliance with the requirements of Volume 1, Wisconsin State Electrical Code, is required before a utility may provide electric service even though some portions of the code may not be directly enforceable by state agencies. See s. 167.16, Stats. The authority for the enforcement of Volume 1, Wisconsin State Electrical Code, is vested in the public service commission with respect to the installation and operation of circuits or equipment by public utilities and railroads in the exercise of their functions as utilities and railroads.

Note: While the commission does not have jurisdiction for enforcement of Volume 1, Wisconsin State Electrical Code, over parties other than public utilities and railroads, electric utilities are prohibited under s. 167.16, Stats., from extending electric service for premises which are not in compliance with the Wisconsin State Electrical Code, which includes both Volumes 1 and 2.

(b) The requirements in the code are enforceable in the same manner as other orders of the public service commission. See s. 102.57, 102.58, 195.07, 196.41, 196.64, 196.66, 196.74, and ch. 227, Stats.

(3) OTHER REQUIREMENTS. (a) There are state statutes that refer directly to certain electrical construction. Some of these are s. 66.047, 86.16, 134.40, 134.41, 167.16, 182.017, 182.0175, 182.018, 196.171, 196.58, 196.67, 196.72, 196.81, and 893.28(2), Stats.

(b) Nothing in this code shall be construed to deprive a municipality of jurisdiction over utilities, places of employment or public buildings, except that no local requirements shall be less stringent than the requirements in this chapter. See s. 196.58, Stats.

(c) A utility may file with the public service commission, as a condition of a rate application, requirements covering subject matter which is a part of this code, but such requirements must be acceptable and not less stringent than the requirements of this chapter. See s. 196.19, Stats.

(4) COMPLAINTS. If a complaint is filed with the public service commission by any interested party to the effect that public safety requires changes in construction or methods of operation, the public service commission shall investigate and make recommendations. See s. 196.74, Stats., for procedure if changes in utility facilities are necessary.

PSC 114.04 GENERAL REQUIREMENTS. (1) CHARACTER OF CONSTRUCTION, MAINTENANCE AND OPERATION. All electrical power and communication equipment and lines shall be of such construction, and so installed, operated and maintained as to minimize the life and fire hazard.

(2) CONSTRUCTION, INSPECTION AND REPAIRS. (a) All construction and equipment shall be cleaned when necessary and inspected at such intervals as experience has shown to be necessary. Any equipment or construction known to be defective so as to endanger life or property shall be promptly repaired, permanently disconnected, or isolated until repairs can be made. Construction, repairs, additions and changes to electrical equipment and conductors shall be made by qualified persons only.

(b) Facilities installed or used in the generation, transmission, distribution and utilization of electricity shall be designed for such installation and use.

PSC 114.05 APPLICATION OF RULES. (1) The intent of the requirements of this chapter will be realized:

(a) by applying the requirements in full to all new installations, reconstructions, alterations and extensions, except when any requirement is shown to be impracticable for special reasons or where the advantage of uniformity with existing construction is greater than the advantage of construction in compliance with this chapter, providing the existing construction is reasonably safe;

(b) by bringing existing installations into conformity with this chapter as directed by the commission and within the time determined by said agency; or

(c) where the requirement is waived by the public service commission under ss. (3).

(2) EXISTING INSTALLATIONS. (a) Existing installations, including maintenance replacements, which comply with prior editions of the code, need not be modified to comply with this chapter except as may be required for safety reasons by the administrative authority.

(b) Where conductors or equipment are added, altered, or replaced on an existing structure, the structure or the facilities on the structure need not be modified or replaced if the resulting installation will be in compliance with the rules which were in effect at the time of the original installation.

(3) WAIVING RULES. The rules are intended to apply to all installations, except as modified or waived by the public service commission. The requirements are intended to be so modified or waived in particular cases whenever any rules are shown for any reason to be impracticable or if equivalent or safer construction is secured in other ways.

(4) TEMPORARY INSTALLATIONS. Temporary construction which is shortly to be dismantled or reconstructed may be used for a reasonable length of time without fully complying with this code, provided it is under competent supervision while it or adjoining equipment is alive, or if it is protected by suitable barriers or warning signs when accessible to any person, but all such construction shall be made reasonably safe.

(5) TESTING. Rooms which are used exclusively for routine or special electrical test work, and therefore are under the supervision of a qualified person, need comply with this code only to the extent practicable for the character of the testing done.

(6) EMERGENCY. In case of emergency the person responsible for the installation may decide to modify or waive any requirement of this chapter, subject to review by the commission, even should an application be pending before the commission for a requested emergency related modification or waiver.

(7) INTENT. Rules in this code which are to be regarded as mandatory are characterized by the use of the word *shall*. Where a rule is of an advisory nature, it is indicated by the use of the word *should*. Other practices which are considered desirable are stated as RECOMMENDATIONS. NOTES contained herein, other than footnotes to tables, are for information purposes only and are not to be considered as mandatory or as part of the code requirements.

PSC 114.06 ADOPTION OF STANDARD BY REFERENCE. (1) ADOPTION OF STANDARD. The National Electrical Safety Code - 1981, subject to omissions, changes and additions as otherwise shown in this chapter, is hereby incorporated by reference into the Wisconsin State Electrical Code, Volume 1.

Note: Interim amendment to the NESC-1981 will not be effective in this state until such time as this chapter is revised to reflect such changes.

(2) CONSENT TO INCORPORATE NESC-1981 BY REFERENCE. Pursuant to s. 227.025, Stats., the attorney general and the revisor of statutes have consented to the incorporation by reference of these standards contained in the NESC-1981, except for the omissions as shown in s. PSC 114.07 and the changes and additions as shown in subsequent sections of this chapter. Copies of the NESC-1981 standard code are on file in the offices of the public service commission, the secretary of state, and the revisor of statutes.

PSC 114.07 OMISSIONS FROM NESC-1981. (1) The following portions of the NESC-1981 are not incorporated as part of the Wisconsin State Electrical Code, Volume 1:

(a) All of Section 1, Introduction to National Electrical Safety Code, pp. 47-48; and Rule 180B8, p. 125.

(b) The following other portions, all of which relate to alternate clearance requirements based on known switching surge factors:

	<u>Page</u>
232B1a - Exception	147
232C2a - Exception	151
Table 232-3	152-153
232D	153-155
233C2a - Exception	161
233C3	165-167
Table 233-2	166
234F1a - Exception	178
234G	180-183
Table 234-4	182
235B1 - Exception 4	185
235B3	188-189
Table 235-4	190
235C2a - Exception	191
235C3	194
235E1 - Exception	195
235E3	198-199
Table 235-7	200
Table 1B	321
Table 2B	322

PSC 114.08 CHANGES OR ADDITIONS TO NESC-1981. Following are the changes or additions to the NESC-1981 prescribed by the public service commission. Each change or addition has been prefixed by PSC 114. Following the PSC designation is the referenced NESC section or subsection and the page on which it is found in the NESC. Example: PSC 114-96A3 [NESC 96A3, p. 80]. The word "Change" following the section number and heading means that the corresponding wording of the NESC-1981 has been changed and that the new wording is substituted at the appropriate location. The word "Addition" following the section number and heading means that a new requirement is incorporated in the NESC-1981 and that the new requirement is inserted at the appropriate location.

SECTION 2. DEFINITIONS OF SPECIAL TERMS

Administrative Authority [NESC, p. 51] (Change). The authority for the enforcement of this code is vested in the public service commission with respect to the installation and operation of circuits or equipment by public utilities and railroads in the exercise of their functions as utilities and railroads.

Commission [NESC, p. 51] (Addition). Public service commission.

NESC or NESC-1981 [NESC, p. 51] (Addition). National Electrical Safety Code-1981.

SECTION 9. GROUNDING METHODS FOR ELECTRIC SUPPLY AND COMMUNICATION FACILITIES

PSC 114.96A3 [NESC 96A3, p. 80] Multiple Grounded Systems. (Change) Change the first sentence to read:

The neutral, which shall be of sufficient size and ampacity for the duty involved, shall be connected to made electrodes at each transformer location and at a sufficient number of additional points to total not less than ~~four~~ nine grounds in each mile of line, not including grounds at individual services.

Exception: In underground multiple-grounded systems where an insulating jacket is used over direct-buried concentric neutral supply cable for the purpose of corrosion mitigation, this requirement shall be permitted to be reduced to four grounds in each mile. This exception for use of supply cable with an insulating jacket shall not be permitted for random lay construction. See Part 3, Rule 354, "Random Separation--Additional Requirements."

PSC 114.97C [NESC 97C, p. 81] Separation of Grounding Conductors (Change)

C. Primary and secondary circuits utilizing a single conductor as a common neutral shall have at least ~~four~~ nine ground connections on such conductor in each mile of line exclusive of ground connections at customers' service equipment.

PART 1. RULES FOR THE INSTALLATION AND MAINTENANCE
OF ELECTRICAL SUPPLY STATIONS AND EQUIPMENT

SECTION 11. PROTECTIVE ARRANGEMENTS IN ELECTRICAL
SUPPLY STATIONS

PSC 114-110A [NESC 110A, p. 85] Enclosure of Equipment.
(Change) Change second paragraph and note
to read:

Metal fences, when used to enclose electrical supply stations having energized electrical conductors or equipment that can be reached by trespassers, shall be a minimum of seven feet in height and shall be effectively grounded. In the case of chain-link, mesh or other open-type fences through which sticks or other objects can be inserted to make contact with live parts or parts that may become alive, horizontal clearance as specified in column 3 of Table 124-1, Minimum Clearance from Live Parts, shall be provided. Other types of construction such as non-metallic material shall present equivalent barriers to climbing or other unauthorized entry. These requirements shall also apply to fences around existing electrical supply stations when fencing additions are made.

Note: It is recommended that, where permissible, a one-foot extension carrying three strands of barbed wire be used above the fence fabric, either as an outside or inside the fence overhang or as a vertical extension of the fence, to obtain the required overall height.

PSC 114-111E [NESC 111E, p. 89] Receptacles in Damp or Wet Locations (Change) Change subsection to read:

E. Receptacles in Damp or Wet Locations

All 120 V ac receptacles shall either be provided with ground fault interruptor (GFI) protection, or be on a grounded circuit which is periodically tested.

SECTION 12. INSTALLATION AND MAINTENANCE OF EQUIPMENT

PSC 114-127 [NESC 127, p. 100] Hazardous Locations (Change)
Change the first sentence of the introductory
paragraph to read:

Electrical installations in hazardous areas shall meet the requirements of articles 500 through 503 and articles 511 through 517 of the National Electrical Code-1981.

SECTION 18. SWITCHGEAR AND METAL ENCLOSED BUS

PSC 114-180B7 [NESC 180B7, p. 124] Metal Enclosed Power Switchgear (Change) Change paragraph to read:

7. Low-voltage cables or conductors, except those to be connected to equipment within the compartment, which are routed through medium or high voltage divisions of switchgear shall be isolated by grounded metal barriers.

PART 2. SAFETY RULES FOR THE INSTALLATION AND MAINTENANCE OF OVERHEAD ELECTRIC SUPPLY AND COMMUNICATION LINES

SECTION 20. PURPOSE, SCOPE AND APPLICATION OF RULES

PSC 114-202 [NESC 202, p. 131] Application of Rules (Change) Change the first sentence to read:

The general requirements for application of these rules are contained in Rule PSC 114.05.

SECTION 21. GENERAL REQUIREMENTS

PSC 114-217 [follows NESC 216, p. 134] Marking of Poles and Structures Carrying High Voltage Supply Lines (Addition) Add the following section:

PSC 114-217 MARKING OF POLES AND STRUCTURES CARRYING HIGH VOLTAGE SUPPLY LINES. A. Section 196.67, Stats., provides the following in part:

196.67 Warning signs. (1) Every corporation, company or person constructing, operating or maintaining an electric transmission line with a voltage of six thousand or more between conductors or between conductors and the ground shall place warning signs, not less than four feet nor more than six feet from the ground, upon all poles or other structures supporting such line when within one hundred feet of school grounds; and when within one hundred feet of any place where such line crosses a public highway; and when within any city or village.

(2) Every such sign shall be in red, black, orange or reflective letters not less than 2 inches high on a contrasting background and shall read "Danger--High Voltage." The commission may establish standards for electric transmission line pole signs having at least equivalent warning qualities to signs specified in this subsection, and warning signs meeting standards established or approved by the commission shall be deemed to be in compliance with this section.

B. The following shall constitute standards established by the commission for warning signs on overhead electrical supply line poles and structures:

1. "Danger--High Voltage" warning signs which meet the requirements as to format of subsections 1926.200(a) and (b) of Part 1926-Safety and Health Regulations for Construction-1979 (OSHA) as found in the Code of Federal Regulations, subject to the following conditions:

a. The overall dimensions of these signs shall not be less than 10 inches by 7 inches except that in those situations where use of a sign this size is not practicable, two or more signs not smaller than 7 inches by 5 inches may be substituted, and

b. Letters of the words "High Voltage" shall be in red, black, orange or reflective letters on the contrasting white background and at least 2 inches in height.

Exception: For those specific signs having dimensions of 10 inches horizontal by 7 inches vertical the height of letters shall not be less than $1\frac{1}{4}$ inches.

C. Warning signs installed as replacements or installed as new facilities shall comply with the standards as prescribed in PSC 114-217B.

PSC 114-231C [NESC 231C, p. 140] Clearances from Railroad Tracks.
(Change) Change Exception 1 to read:

Exception 1. At industrial sidings, a clearance of not less than 7 feet shall be permitted where a supporting structure is not the controlling obstruction, provided sufficient space for a driveway is left where cars are loaded or unloaded.

Table PSC 114-232-1 [NESC, Table 232-1, pp. 142-146] Minimum Vertical Clearance of Wires, Conductors and Cables Above Ground, Rails, or Water (Changes and Additions)

Table PSC 114-232-1 which follows includes the following changes and additions in NESC Table 232-1:

Footnotes 8(a) and 17 have been changed.

Footnote 10 has also been applied to item 9, column 3.

Footnote 18 has been deleted.

Footnote 23 has been deleted.

A new Footnote 23 has been added.

Footnote 24 has been added.

Item 7 contains different requirements for clearances over water areas.

Table PSC 114-232-1.

Minimum Vertical Clearance of Wires, Conductors, and Cables Above Ground, Rails, or Water

(Voltages are phase to ground for effectively grounded circuits and those other circuits where all ground faults are cleared by promptly de-energizing the faulted section, both initially and following subsequent breaker operations. See the definition section for voltages of other systems.)

Nature of surface under-neath wires, conductors, or cables	Communication conductors and cables, guys, messengers, surge protection wires, neutral conductors meeting Rule 230E1, and supply cables meeting Rule 230 C1 (11) (ft)	Supply line conductors, street lighting conductors, and service drops (23)				Trolley and electrified railroad contact conductors and associated span or messenger wires (1)	
		Open supply line conductors 0 to 750 V. Supply cables of all voltages meeting Rule 230C2 or 230C3 (ft)	Open supply line conductors		0 to 750 V to ground (ft)	750 V to 50 kV to ground (ft)	
			750 V to 15 kV (ft)	15 to 50 kV (ft)			
Where wires, conductors, or cables cross over or overhang							
1. Track rails of railroads (except electrified railroads using over-head trolley conductors) (2) (16) (20)	(3) (15) 27	(3) 27	(3) 28	30	(4) 22	(4) 22	
2. Roads, streets, alleys; nonresidential driveways, parking lots, and other areas subject to truck traffic (21) (22)	(13) (6) 18	18	20	22	(5) 18	(5) 20	
3. Residential driveways; commercial areas not subject to truck traffic (21) (22)	10	(8) 15	20	22	(5) 18	(5) 20	
4. Other land traversed by vehicles such as cultivated, grazing, forest, orchard, etc	(24) 18	18	20	22	-	-	
5. Spaces or ways accessible to pedestrians only (9)	(7) 15	(8) (14) 15	15	17	16	18	
6. Water areas not suitable for sailboating or where sailboating is prohibited (19)	15	15	17	17	-	-	
7. Water areas suitable for sailboating including lakes, ponds, reservoirs, tidal waters, rivers, streams, and canals with an unobstructed surface area of: (17) (19)							
(a) Less than 10 acres	18	18	20	22	-	-	
(b) 10 to 80 acres	30	30	31	33	-	-	
(c) Over 80 acres	40	40	40	42	-	-	
8. Public or private land and water areas posted for rigging or launching sailboats		Clearance above ground shall be 5 ft greater than in 7 above, for the type of water areas served by the launching site					
Where wires, conductors, or cables run along and within the limits of highways or other road rights-of-way but do not overhang the roadway							
9. Roads, streets, or alleys in urban districts	(13) (10) 18	(10) 18	20	22	(5) 18	(5) 20	
10. Roads in rural districts where it is unlikely that vehicles will be crossing under the line	(10) (12) 14	(10) 15	18	20	(5) 18	(5) 20	

Footnotes for Table PSC 114-232-1:

① Where subways, tunnels, or bridges require it, less clearances above ground or rails than required by Table 232-1 may be used locally. The trolley and electrified railroad contact conductor should be graded very gradually from the regular construction down to the reduced elevation.

② For wire, conductors, or cables crossing over mine, logging, and similar railways which handle only cars lower than standard freight cars, the clearance may be reduced by an amount equal to the difference in height between the highest loaded car handled and 20 ft, but the clearances shall not be reduced below that required for street crossings.

③ These clearances may be reduced to 25 ft where paralleled by trolley-contact conductor on the same street or highway.

④ In communities where 21 ft has been established, this clearance may be continued if carefully maintained. The elevation of the contact conductor should be the same in the crossing and next adjacent spans. (See Rule 289D2 for conditions which must be met where uniform height above rail is impractical.)

⑤ In communities where 16 ft has been established for trolley and electrified railroad contact conductors 0 to 750 V to ground, or 18 ft for trolley and electrified railroad contact conductors exceeding 750 V, or where local conditions make it impractical to obtain the clearance given in the table, these reduced clearances may be used if carefully maintained.

⑥ If a communication service drop or a guy which is effectively grounded or is insulated against the highest voltage to which it is exposed, up to 8.7 kV, crosses residential streets and roads, the clearance may be reduced to 16 ft at the side of the traveled way provided the clearance at the center of the traveled way is at least 18 ft. This reduction in clearance does not apply to arterial streets and highways which are primarily for through traffic, usually on a continuous route.

⑦ This clearance may be reduced to the following values:

	<i>feet</i>
(a) For insulated communication conductors and communication cables	8
(b) For conductors of other communication circuits	10
(c) For guys	8
(d) For supply cables meeting Rule 230C1	10

⑧ This clearance may be reduced to the following values:

	<i>feet</i>
(a) Supply conductors limited to 300 V to ground.	12
(b) Drip loops of supply conductors limited to 150 V to ground and meeting Rules 230C2 or 230C3 and located at the electric service entrance to buildings.	10

⑨ Spaces and ways accessible to pedestrians only are areas where vehicular traffic is not normally encountered or not reasonably anticipated.

⑩ Where a supply or communication line along a road is located relative to fences, ditches, embankments, etc, so that the ground under the line would not be expected to be traveled except by pedestrians, this clearance may be reduced to the following values:

	<i>feet</i>
(a) Insulated communication conductor and communication cables	8
(b) Conductors of other communication circuits	10
(c) Supply cables of any voltage meeting Rule 230C1 and supply cables limited to 150 V to ground meeting Rules 230C2 or 230C3	10
(d) Supply conductors limited to 300 V to ground	12
(e) Guys	8

⑪ No clearance from ground is required for anchor guys not crossing track rails, streets, driveways, roads, or pathways.

⑫ This clearance may be reduced to 13 ft for communication conductors.

⑬ Where communication wires or cables or supply cables meeting Rule 230C1 cross over or run along alleys, driveways, or parking lots, this clearance may be reduced to 15 ft for spans limited to 150 ft.

⑭ Where supply circuits of 600 V or less, with transmitted power of 5000 W or less, are run along fenced (or otherwise guarded) private rights-of-way in accordance with the provisions specified in Rule 220B2, this clearance may be reduced to 10 ft.

⑮ The value may be reduced to 25 ft for guys, for cables carried on messengers, and for supply cables meeting Rule 230C1. This value may be reduced to 25 ft for conductors effectively grounded throughout their length and associated with supply circuits of 0 to 22 kV, only if such conductors are stranded, are of corrosion-resistant material, and conform to the strength and tension requirements for messengers given in Rule 261I.

⑯ Adjacent to tunnels and overhead bridges which restrict the height of loaded rail cars to less than 20 ft, these clearances may be reduced by the difference between the highest loaded rail car handled and 20 ft, if mutually agreed to by the parties at interest.

⑰ For controlled impoundments, the surface area and corresponding clearances shall be based upon the design high water level. For other waters, the surface area and clearances shall be based on the normal high water level.

The clearance over rivers, streams, and canals shall be based upon the largest surface area of any 1 mi long segment which includes the crossing. The clearance over a canal, river, or stream normally used to provide access for sailboats to a larger body of water shall be the same as that required for the larger body of water.

⑱ Where the US Army Corps of Engineers, or the State, or a surrogate thereof has issued a crossing permit, clearances of that permit shall govern.

⑲ See Rule 234H for the required horizontal and diagonal clearances to rail cars.

Footnotes for Table PSC 114-232-1 (continued)

②① These clearances do not allow for the future road resurfacing.

②② For the purpose of this rule, trucks are defined as any vehicle exceeding 8 ft in height.

②③ A diagonal clearance the same as the vertical clearance shall be maintained to uneven or sloping terrain within a horizontal distance of $\frac{3}{4}$ of the vertical clearance, all distances to be measured from the conductors in their wind-displaced position as defined in Rule 234A1.

②④ The clearance for communication conductors and cables not supported by a messenger shall be permitted to be installed at a minimum of 15 feet.

Table PSC 114-232-2 [NESC, Table 232-2, pp. 150-151] Minimum Vertical Clearance of Rigid Live Parts Above Ground (Addition)

Table PSC 114-232-2 which follows includes the following addition to NESC Table 232-2:

Footnote 7 has been added.

Table PSC 114-232-2. Minimum Vertical Clearance of Rigid Live Parts Above Ground

(Voltages are phase to ground for effectively grounded circuits and those other circuits where all ground faults are cleared by promptly de-energizing the faulted section, both initially and following subsequent breaker operations. See the definition section for voltages of other systems.)

Nature of surface below live parts	0 to 750 V (ft)	750 V to 15 kV (ft)	15 to 50 kV (ft)
1. Where live parts overhang:			
a. Roads, streets, alleys; nonresidential driveways; parking lots and other areas subject to truck traffic ④⑤	16	18	⑦ ₂₀
b. Residential driveways; commercial areas not subject to truck traffic ④⑤	①13	18	⑦ ₂₀
c. Other land traversed by vehicles such as cultivated land, grazing land, forest, orchard, etc.	16	18	⑦ ₂₀
d. Spaces and ways accessible to pedestrians only.⑥	①③④13	13	15
2. Where live parts are along and within the limits of highways or other road rights-of-way but do not overhang the roadway:			
a. Roads, streets, and alleys	②16	18	⑦ ₂₀
b. Roads in rural districts where it is unlikely that vehicles will be crossing under the line	②13	16	18

① This clearance may be reduced to the following values:

- | | |
|---|-------------------|
| (a) Live parts limited to 300 V to ground | <i>feet</i>
12 |
| (b) Live parts limited to 150 V to ground and short lengths of supply cables meeting Rule 230C2 or 230C3 and located at the electric service entrance to building | 10 |

② Where a supply line along a road is limited to 300 V to ground and is located relative to fences, ditches, embankments, etc, so that the ground under the line would not be expected to be traveled except by pedestrians, this clearance may be reduced to 12 ft.

③ Where supply circuits of 600 V or less, with transmitted power of 5000 W or less, are run along fenced (or otherwise guarded) private rights-of-way in accordance with the provisions specified in Rule 220B2, this clearance may be reduced to 10 ft.

④ For the purpose of this rule, trucks are defined as any vehicle exceeding 8 ft in height.

⑤ These clearances do not allow for future road resurfacing.

⑥ Spaces and ways accessible to pedestrians only are areas where vehicular traffic is not normally encountered or not reasonably anticipated.

⑦ Except for rigid live parts overhanging alleys this clearance shall be permitted to be reduced to 18 feet.

PSC 114-234A4 [follows NESC 234A3, p. 168] Transmission Lines Over Dwelling Occupancies (Addition) Add the following paragraph:

4. Transmission Lines Over Dwelling Occupancies

Supply lines designed to operate at voltages in excess of 35 kV shall not be constructed over dwelling occupancies or mobile homes intended for residential occupancy and dwelling occupancies or mobile homes intended for residential occupancy shall not be located under such lines. This provision also applies to line conductors in their wind-displaced position as defined in Rule 234A1.

Note: Electric utilities are prohibited by s. 167.16, Stats., from extending electric service to premises which are not in compliance with the Wisconsin State Electrical Code.

Table PSC 114-234-1 [NESC Table 234-1, pp. 170-171] Clearance of Supply Wires, Conductors, and Cables Passing By But Not Attached to Buildings and Other Installations Except Bridges (Changes and Additions)

Table PSC 114-234-1 which follows contains the following changes and additions:

Footnote 6 has been changed.

Footnotes 8 and 9 have been added.

The fourth entry from the top in column 2 has been changed.

Table PSC 114-234-1.

Clearance of Supply Wires, Conductors, and Cables Passing By But Not Attached To Building and Other Installations Except Bridges

(Voltages are phase to ground for effectively grounded circuits and those other circuits where all ground faults are cleared by promptly de-energizing the faulted section, both initially and following subsequent breaker operations. See the definitions section for voltages of other systems.)

Clearance of	Communication conductors and cables, guys, messengers, lightning protection wires, neutral conductors meeting Rule 230E1, supply cables of all voltages meeting Rule 230C1, and supply cables of 0 to 750 V meeting Rule 230C2 or 230C3 (ft)	Supply line conductors, street lighting conductors, and service drops			
		Open supply line conductors 0 to 750 V, and supply cables over 750 V meeting Rule 230C2 or 230C3 (ft)	Open supply line conductors		
			750 V to 8.7 kV (ft)	8.7 to 15 kV (ft)	15 to 50 kV (ft)
Buildings					
Horizontal					
To walls and projections	⑨ 3	②① 5	①② 5	③ 8	③ 10
To unguarded windows	⑨ 3	②① 5	5	8	10
To balconies and areas accessible to pedestrians ④	3	5	5	8	10
Vertical					
Above or below roofs or projections not accessible to pedestrians ④	⑧ 8	10	10	10	12
Above or below balconies and roofs accessible to pedestrians ④	8	⑥ 15	15	15	17
Above roofs accessible to truck traffic ⑦	18	18	20	20	22
Above roofs accessible to vehicles, but not subject to truck traffic ⑦	10	⑥ 15	20	20	22
Signs, chimneys, radio and television antennas, tanks, and other installations not classified as buildings or bridges ⑤					
Horizontal	3	①② 5	①② 5	③ 8	③ 10
Vertical above or below	3	① 5	8	8	10

① Where building, sign, chimney, antenna, tank, or other installation does not require maintenance such as painting, washing, changing of sign letters, or other operation which would require persons to work or pass between supply conductors and structure, the clearance may be reduced to 3 ft.

② Where available space will not permit this value, the clearance may be reduced to the maximum practical clearance but the minimum clearance may not be less than 3 ft provided the conductors, including splices and taps, have covering which provides sufficient dielectric to prevent a short circuit in case of a momentary contact between the conductors and a grounded surface.

③ Where available space will not permit these values, the clearance may be reduced by 2 ft if the conductors, including splices and taps, have covering which provides sufficient dielectric to prevent a short circuit in case of a momentary contact between the conductors and a grounded surface.

④ A roof, balcony, or area is considered accessible to pedestrians if the means of access is through a doorway, ramp, stairway, or permanently mounted ladder.

⑤ The required clearances shall be increased to allow for the movement of motorized signs and other movable attachments to any installation covered by Rule 234C.

⑥ This clearance may be reduced to 12 ft for supply conductors limited to 300 V to ground.

⑦ For the purpose of this rule, trucks are defined as any vehicles exceeding 8 feet in height.

⑧ This clearance may be reduced to 3 ft for supply conductors limited to 300 V to ground and communication conductors and cables if the roof has a slope of not less than 4 in 12 in.

⑨ This clearance may be reduced to 6 in for guys not crossing directly in front of unguarded windows.

PSC 114-234C4c [NESC 234C4c, p. 173] Supply Conductors Attached to Buildings (Change) Change Exception 1 to read as follows:

Exception 1: Where the voltage between conductors does not exceed 300 volts and the roof has a slope of not less than 4 inches in 12 inches, the clearance may be reduced to 3 feet.

PSC 114-234C4d [follows NESC 234C4c, p. 173] Supply Conductors Attached to Buildings (Addition) Add the following subdivision:

- d. Service conductors not in excess of 600 volts between conductors shall have a clearance of not less than 3 feet from windows, doors, porches, fire escapes or similar locations.

Exception: This requirement does not apply to conductors that run above the top level of a window.

PSC 114-234C6 [follows NESC 234C5, p. 173] Near Stored Materials (Addition) Add the following paragraph:

6. Near Stored Materials

Lines should not be run over areas where material is regularly stored and handled by cranes, dump trucks, elevators or other types of high machinery unless the clearance of such lines is adequate to permit full use of the equipment. Also, material which requires the use of such high machinery should not be stored near or under existing lines.

PSC 114-234C7 [follows NESC 234C5, p. 173] Near Fuel Storage Tanks (Addition) Add the following paragraph:

7. Near Fuel Storage Tanks

A horizontal clearance of not less than 8 feet shall be maintained between above-ground flammable liquids and liquefied petroleum gas storage tanks and supply cables of all voltages meeting Rule 230C2 or 230C3. A horizontal clearance of not less than 15 feet shall be maintained between such fuel storage tanks for all other supply conductors.

Exception: These requirements do not apply to liquefied petroleum gas tanks with capacity of 1,000 gallons or less.

PSC 114.234C8 [follows NESC 234C5, p. 173] Near Wells. (Addition) Add the following paragraph:

8. Near Wells

A horizontal distance of at least 3/4 of the required vertical clearance of the conductors to ground (Rule 232) shall be maintained between open conductors and wells. Persons installing such wells shall also comply with this requirement.

Note: Electric utilities are prohibited by s. 167.16, Stats., from extending electric service to premises which are not in compliance with the Wisconsin State Electrical Code.

PSC 114-234E1 [NESC 234E1, p. 176] Clearance of Wires, Conductors, or Cables Installed Over or Near Swimming Areas (Change) Change paragraph to read:

1. Swimming Pools

Where wires, conductors, or cables cross over a swimming pool or the surrounding area within 10 ft. of the inside wall of the pool, the clearances in any direction shall be as shown in Figure PSC 114-234-2. The values of A, B, C and D are specified in Table PSC 114-234-3.

Exception: This rule does not apply to a pool fully enclosed by a solid or screened permanent structure.

Figure PSC 114-234-2 [NESC Figure 234-2, p. 176] Swimming Pool Clearances (Change)

Figure PSC 114-234-2

Swimming Pool Clearances

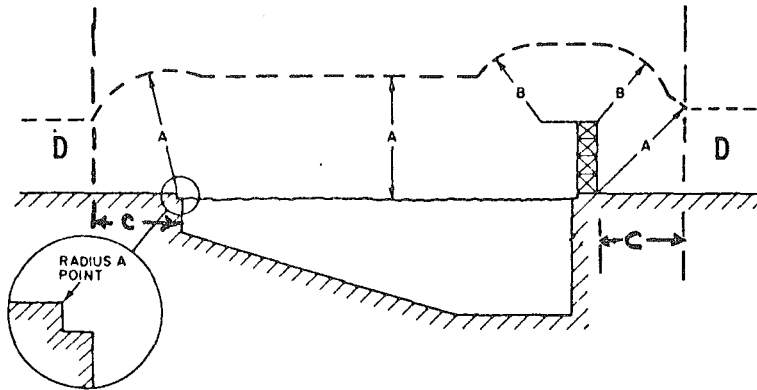

Table PSC 114-234-3 [NESC, Table 234-3, p. 177] Clearance of Supply Wires, Conductors, and Cables Passing Over or Near Swimming Areas (Change and Addition)

Table PSC 114-234-3 which follows includes the following changes in NESC Table 234-3:

Line C has been changed.
Line D has been added.

Table PSC 114-234-3.

Clearance of Supply Wires, Conductors, and Cables Passing Over or Near Swimming Areas (Voltages are phase to ground for effectively grounded circuits and those other circuits where all ground faults are cleared by promptly de-energizing the faulted section, both initially and following subsequent breaker operations. See the definitions section for voltages of other systems.)

Supply line conductors, street lighting conductors, and service drops					
	Supply cables, 0 to 750 V meeting Rules 230C2 or 230C3; Neutral conductors meeting Rule 230E1 (ft)	Open supply line conductors 0 to 750 V and supply cables over 750 V meeting Rules 230C2 or 230C3 (ft)	Open supply line conductors		
			750 V to 8.7 kV (ft)	8.7 to 15 kV (ft)	15 to 50 kV (ft)
A: Clearance in any direction from the water level, edge of pool, base of diving platform, or anchored raft	18	25	25	25	27
B: Clearance in any direction to the diving platform or tower	14	16	16	16	18
C: Horizontal limit of clearance measured from inside wall of pool	This limit shall extend to the area adjacent to the pool and to the outer edge of a diving tower or platform, but not less than 10 ft. measured from the inside of the wall of the pool.				
D: Vertical clearance over adjacent land	Clearance as required by Rule 232.				

Note: A, B, C and D are shown in Figure PSC 114-234-2.

PSC 114-236J [follows NESC 236I, p. 206] Climbing Space in Rack Construction (Addition) Add the following subsection:

J. Climbing Space in Rack Construction

Where the voltage between conductors is less than 600 volts, climbing space shall be maintained through the levels of conductors supported in rack construction and for a vertical distance of not less than 40 inches above the top conductor and not less than 40 inches below the bottom conductor so supported. The width of the climbing space measured horizontally through the center of the pole shall be not less than 5 inches plus the diameter of the pole. The depth of the climbing space shall be not less than 30 inches measured perpendicularly to this climbing space boundary through the center line of pole. The width of the climbing space, perpendicular to and at the extremity of this 30-inch depth dimension, shall be not less than 38 inches and neither of the other 2 side boundaries shall make an angle of less than 90 degrees with the boundary through the center line of pole. The climbing spaces through the levels of conductors of two or more rack groups which are separated less than 6 feet shall be maintained in the same quadrant or on the same side of the pole. Vertical conductors are not permitted in the climbing spaces through conductors in rack construction.

Figure PSC 114-236J depicts the general climbing space past rack construction.

Figure PSC 114-236J. Climbing Space Past Rack Construction

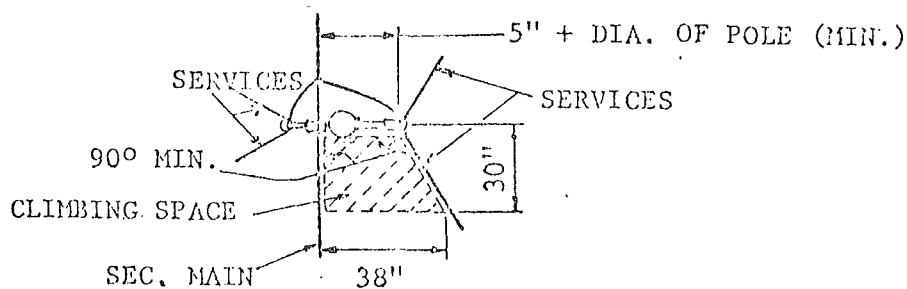

PSC 114-238D [NESC 238D, p. 208] Clearance from Drip Loops of Luminaire Brackets (Change) Change subsection to read:

D. Clearance from Drip Loops of Luminaire Brackets

If a drip loop of conductors entering a luminaire bracket from the surface of the structure is above a communication cable, the lowest point of the loop shall be at least 12 inches above the communication cable or through bolt unless guarded. The conductor shall not be closer than 2 inches to the open bottom of the guard.

PSC 114-239C [NESC 239C, p. 211] Mechanical Protection Near Ground (Addition) Add the following as the second sentence in the subsection:

Raceways installed on poles for supply conductors shall be of rigid metal conduit, intermediate metal conduit, PVC Schedule 80 or equivalent nonmetallic conduit, or galvanized steel U-guards extending from at least 1 ft. below ground level up to a point 8 ft. above finished grade.

PSC 114-239F7 [follows NESC 239F6, p. 215] Requirements for Vertical Supply Conductors Passing Through Communication Space on Jointly Used Line Structures (Addition) Add the following subsection.

7. Multiple-Conductor Cables Attached Directly to Surface of the Line Structure

Multiple-conductor cables operating at voltages not exceeding 600 volts between conductors may be attached directly to the surface of the line structure if protected by a suitable nonmetallic covering in addition to the normal conductor insulation. The nonmetallic covering may consist of a U-guard or other suitable nonmetallic covering. Each conductor shall be insulated for a potential of at least 600 volts. Where used as aerial services, the point where such cables leave the structure shall be at least 40 inches above the highest or 40 inches below the lowest communication attachment. All splices and connections in the cable shall be insulated.

SECTION 24. GRADES OF CONSTRUCTION

Table PSC 114-242-1 [NESC, Table 242-1, pp. 220-222]
 Grades of Construction for Supply Conductors
 Alone, at Crossing, or on the Same
 Structures With Other Conductors (Addition)
 Table PSC 114-242-1, which follows, contains the following
 addition:

Footnote 11 has been added.

Table PSC 114-242-1.
 Grades of Construction for Supply Conductors Alone, at Crossing,
 or on the Same Structures With Other Conductors

(The voltages listed in this table are line to ground values for: effective grounded ac circuits, two wire grounded circuits, or center grounded dc circuits; otherwise line to line values shall be used. The grade of construction for supply conductors, as indicated across the top of the table, must also meet the requirements for any lines at lower levels except when otherwise noted.)

Supply conductors at higher levels ①	Constant-potential supply conductors						Constant current supply conductors		Communication conductors used exclusively in the operation of and run as supply lines													
	0-0.75 kV		0.75-8.7 kV		Exceeding 8.7 kV ⑪																	
	Urban	Rural	Urban	Rural	Urban	Rural	Open	Cable														
	Open or Cable	Open or Cable	Open	Cable	Open	Cable				Open	Cable											
Conductors, tracks and rights of way at lower levels																						
Exclusive private rights-of-way	N	N	②N	N	N	②N	②N	N	N	B, C, or N; see Rule 242A	C or N; see Rule 242C											
Common or public rights-of-way	N	N	C	N	N	N	③C	C	N			N										
Railroad tracks and limited access highways	B	B	B	B	B	B	B	B	B	B	B											
Constant potential supply conductors										B, C, or N; see Rule 242A	B, C, or N; see Rule 242C											
0 to 750 V																						
Open or cable	N	N	C	N	N	N	③C	C	④C			N										
750 V to 8.7 kV																						
Open	⑤C	N	C	C	N	N	③C	C	N			N										
Cable	N	N	C	N	N	N	③C	C	N	N												
Exceeding 8.7 kV																						
Open	⑤B	⑤C	B	B	N	N	③C	C	N	N												
Cable	⑤C	N	C	N	N	N	③C	C	N	N												
Constant current supply conductors: Open or cable	B, C, or N; see Rule 242A						B, C, or N; see Rule 242A		B, C, or N; see Rules 242A and 242C													
Communication conductors: Open or cable, used exclusively in the operation of supply lines ⑩	B, C, or N; see Rule 242C						B, C, or N; see Rules 242A and 242C		B, C, or N; see Rule 242C													
Communication conductor: Urban or rural, open or cable ⑥	N	N	⑦ ⑧B	C	⑦ ⑧B	C	⑧B	C	⑧B	C	⑧B	C	⑧B	C	⑧B	C	⑧B	C	⑧B	C	C or N; see Rule 242A	B, C, or N; see Rule 242C

Footnotes for Table PSC 114-242-1:

①The words "open" and "cable" appearing in the headings have the following meanings as applied to supply conductors: Cable means the Type 1 cables described in Rule 241A; open means open wire and Type 2 cables.

②Lines that can fall outside the exclusive private rights-of-way shall comply with the grades specified for lines not on exclusive private rights-of-way.

③Supply conductors shall meet the requirements of grade B construction if the supply circuits will not be promptly de-energized, both initially and following subsequent breaker operations, in the event of a contact with lower supply conductors or other grounded objects.

④Grade N construction may be used if crossing over supply services only.

⑤If the wires are service drops, they may have grade N sizes and tensions as set forth in Table 263-2.

⑥Grade N construction may be used where the communication conductors consists only of not more than one insulated twisted-pair or parallel-lay conductor, or where service drops only are involved.

⑦Grade C construction may be used if the voltage does not exceed 2.9 kV.

⑧The supply conductors need only meet the requirements of grade C construction if both of the following conditions are fulfilled:

(1) The supply voltage will be promptly removed from the communication plant by de-energization or other means, both initially and following subsequent circuit breaker operations in the event of a contact with the communication plant.

(2) The voltage and current impressed on the communication plant in the event of a contact with the supply conductors are not in excess of the safe operating limit of the communication protective devices.

⑨Grade C construction may be used if the current cannot exceed 7.5 A or the open-circuit voltage of the transformer supplying the circuit does not exceed 2.9 kV.

⑩Communication circuits located below supply conductors shall not affect the grade of construction of the supply circuits.

⑪Grade B construction shall always be used if the voltage exceeds 175 kV (to ground).

SECTION 25. LOADING FOR GRADES B, C, AND D

PSC 114.250D [follows NESC 250C, p. 228] Longitudinal Capability (Addition) Add the following subsection:

D. Longitudinal Capability

Each supply line designed to operate at 300 kV (phase to phase) or above shall be constructed to limit the effects of a cascading-type failure to a line segment not exceeding 6 miles to 10 miles in length. Such construction requirement may be met by providing at appropriate intervals, structures and associated facilities having full dead-end capability under the loading provisions of 250 A, B and C. Consideration shall be given to factors such as structure type and material, length of line, distance between dead-end or heavy angle structures, and other basic design criteria in determining the length of such individual line segments. For lines supported by "flexible" structures designed with plastic, energy-absorbing capability in failure this requirement may be met if such design and construction will provide equivalent limitation to longitudinal cascading.

PART 3. UNDERGROUND LINES

SECTION 31. GENERAL REQUIREMENTS APPLYING TO UNDERGROUND LINES

PSC 114-311C [follows NESC 311B, p. 277] Installation and Maintenance - Markers (Addition) Add the following subsection:

C. Markers

When underground electric supply lines over 750 volts between conductors are located outside the corporate limits of cities, villages, or developed areas, their location shall be marked in a manner recognizable to the public at each road crossing, railroad crossing, or drainage ditch crossing to identify the location of the facility.

PSC 114-316 [NESC 316, pp. 279-280] Induced Voltage (Addition)
Add the following sentence to the section:

Steady-state induced voltages of 50 volts AC rms or more are considered hazardous for the purposes of this rule.

PSC 114-317 [follows NESC 316, p. 280] Outdoor Location of Oil-Insulated Padmounted Transformers Near Buildings (Addition) Add the following section:

PSC 114-317 OUTDOOR LOCATION OF OIL-INSULATED PADMOUNTED TRANSFORMERS NEAR BUILDINGS.

A. Noncombustible Walls

Padmounted oil-insulated transformers may be located directly next to noncombustible walls if the following clearances are maintained from doors, windows and other building openings:

1. Padmounted oil-insulated transformers shall not be located within a zone extending 20' outward and 10' to either side of a building door. See Figure PSC 114-317A1.

FIGURE PSC 114-317A1.

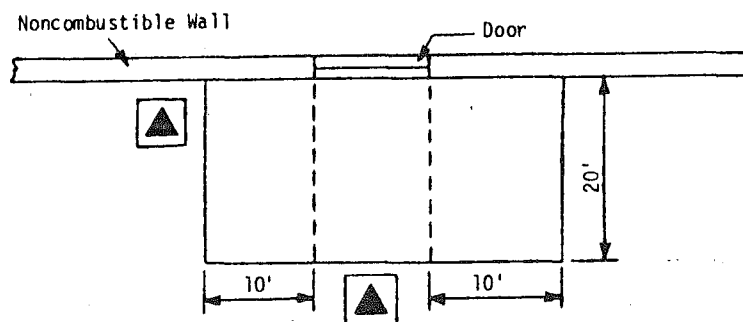

2. Padmounted oil-insulated transformers shall not be located within a zone extending 10' outward and 10' to either side of an air intake opening. Such transformers may be located within said zone beneath an air intake opening provided there is not less than 25 feet separation between the transformer and said opening. See Figure PSC 114-317A2.

FIGURE PSC 114-317A2.

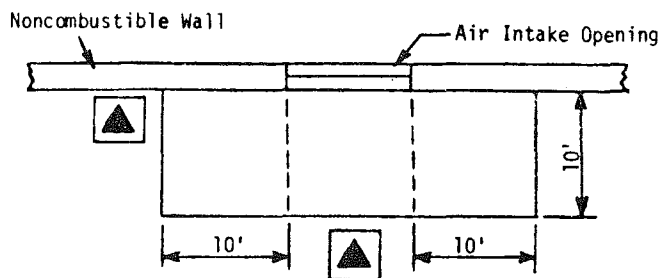

3.a. Padmounted oil-insulated transformers shall not be located within a zone extending 10' outward and 3' to either side of a building window or opening other than an air intake. See Figure PSC 114-317A3a.

FIGURE PSC 114-317A3a.

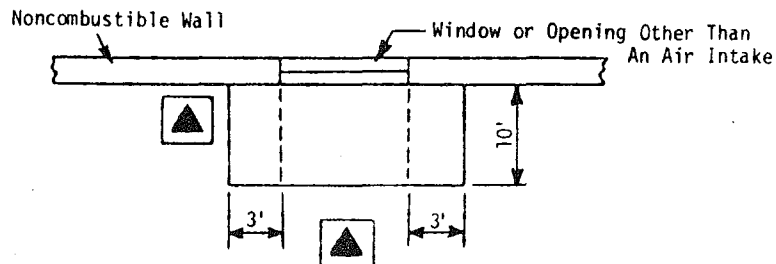

- b. For second story windows, the transformer shall not be located less than 5' from any part of the window. See Figure PSC 317A3b.

FIGURE
PSC 114-
317A3b.

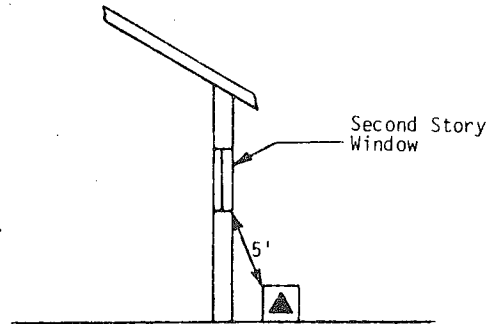

B. Combustible Walls

1. Padmounted oil-insulated transformers in sizes up to 100 kVA shall be located according to the provisions set forth in Subsection A for noncombustible walls.

2. Padmounted oil-insulated transformers in sizes above 100 kVA shall be located a minimum of 10' from the building wall in addition to the clearances from building doors, windows and other openings set forth for noncombustible walls. Also, a sump shall be installed for transformers in sizes exceeding 500 kVA if the immediate terrain is pitched toward the building.

C. Barriers

If the clearances specified above cannot be obtained, a fire-resistant barrier may be constructed in lieu of the separation. The following methods of construction are acceptable:

1. Noncombustible Walls

The barrier shall extend to a projection line from the corner of the padmount to the furthest corner of the window, door or opening in question. The height of the barrier shall be 1' above the top of the padmount transformer. See Figure PSC 114-317C1.

FIGURE PSC 114-317C1.

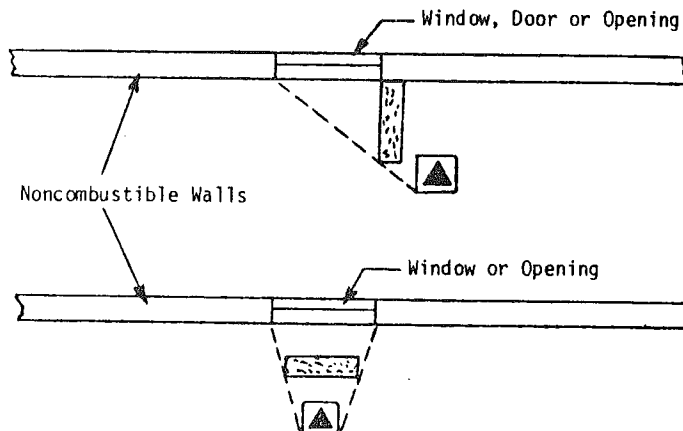

2. Combustible Walls

The barrier shall extend 3' beyond each side of the padmount transformer. The height of the barrier shall be 1' above the top of the transformer. See Figure PSC 114-317C2.

FIGURE PSC 114-317C2.

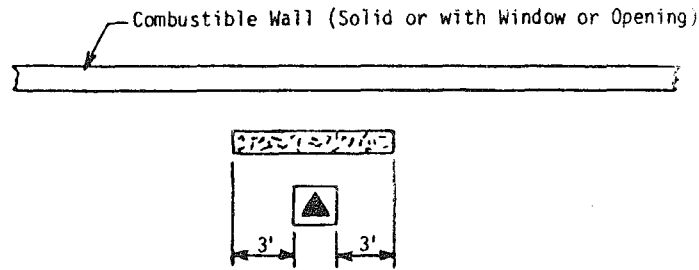

D. Fire Escapes

Padmounted oil-insulated transformers shall be located such that a minimum clearance of 20' is maintained from fire escapes at all times.

SECTION 32. UNDERGROUND CONDUIT SYSTEMS

PSC 114-320B7 [follows NESC 320B6, p. 282] Clearances from Other Underground Installations - Gas Lines (Addition) Add the following paragraph:

7. Gas Lines

a. The separation in any direction of gas transmission lines from electric supply and communications conduit systems shall be a minimum of 12 inches.

b. The separation in any direction of gas distribution or service lines from electric supply and communication conduit systems shall be a minimum of 6 inches.

Exception: If these clearances cannot be attained, the gas line must be protected from damage that might result from the proximity of the electric supply or communication conduit system.

Note: The definition of gas "transmission line," "distribution line," and "service line" as used herein is the same as that found in s. PSC 135.09-192.3, Wis. Adm. Code.

SECTION 35. DIRECT BURIED CABLE

PSC 114-352E [follows NESC 352D, p. 296] Clearances from Other Underground Installations - Gas Lines (Addition) Add the following subsection:

E. Gas Lines

The separation in any direction of gas pipelines from direct buried electric supply and communication facilities shall be a minimum of 12 inches.

Exception: If this clearance cannot be attained, the gas line must be protected from damage that might result from the proximity of the electric supply or communication direct buried system.

SECTION 36. RISERS

PSC 114-360A [NESC 360A, p. 300] General (Change)
Change subsection to read:

- A. Mechanical protection for supply conductors or cables shall be provided as required by Part 2 of this code. Raceways installed on poles shall be of rigid metal conduit, intermediate metal conduit, PVC Schedule 80 or equivalent conduit or galvanized steel U-guards extending from at least 1 foot below ground level up to a point 8 feet above finished grade.

SECTION 38. EQUIPMENT

PSC 114-381H [follows NESC 381G, p. 304] Warning Signs
(Addition) Add subsection to read:

H. Warning Signs

1. Where a padmounted transformer, switchgear, pedestal, or similar above-grade enclosure is not within a fenced or other protected area and contains live parts in excess of 600 volts, a permanent and conspicuous warning sign shall be provided reading substantially as follows:
"Caution--High Voltage Inside--Keep Out."
2. Electric supply equipment installed prior to the effective date of these rules shall be signed to comply with these rules by October 1, 1984.

PART 4. RULES FOR THE OPERATION OF ELECTRIC-SUPPLY AND COMMUNICATIONS LINES AND EQUIPMENT.

SECTION 42. SUPPLY SYSTEMS--RULES FOR EMPLOYEES.

PSC 114-423C [NESC 423C, p. 324] Opening Disconnectors and Tagging (Change) Change the end of the last sentence of NESC 423C from:

". . . and the name of the system operator."

to

". . . and the name or title of the system operator."

PSC 114-423D [NESC 423D, p. 324] Employee's Protective Grounds
(Change) Change the second sentence of NESC 423D
to read:

Grounds shall be placed between the work location and
all sources of energy and as close as practicable to the
work location, or grounds shall be placed at the work
location.

PSC 114-423H [NESC 423H, p. 325] Removal of Tags (Change)
Change the second sentence of NESC 423H from:

"Upon removal of any tag, there shall be added to the
record containing the name of the system operator and
the . . . "

to

"Upon removal of any tag, there shall be added to the
record containing the name or title of the system
operator and the . . . "

PSC 114-423I [NESC 423I, p. 325] Restoring Service (Change)
Change subsection to read:

I. Restoring Service

Only after all protective grounds have been removed
from the line or equipment and after all protective
tags have been removed by the above procedure at a
specific location, may the system operator direct
the closing of disconnectors and switches at that
location.

E N D