

CR 87-156

RULES CERTIFICATE

STATE OF WISCONSIN)
) SS
DEPT. OF INDUSTRY,)
LABOR & HUMAN RELATIONS)

RECEIVED

DEC 21 1988
3:10 pm
Revisor of Statutes
Bureau

TO ALL TO WHOM THESE PRESENTS SHALL COME, GREETINGS:

I, John T. Coughlin, Secretary of the Department of Industry, Labor and Human Relations, and custodian of the official records of said department, do hereby certify that the annexed rule(s) relating to general hazard fire prevention were duly approved and adopted by this department on December 20, 1988.
(Subject) (Date)

I further certify that said copy has been compared by me with the original on file in this department and that the same is a true copy thereof, and of the whole of such original.

IN TESTIMONY WHEREOF, I have hereunto set my hand and affixed the official seal of the department at 1:00 p.m. in the city of Madison, this 20th day of December A.D. 19 88.

John Coughlin
Secretary

4-1-89

RECEIVED

DEC 21 1988

Revisor of Statutes
Bureau

ORDER OF ADOPTION

Pursuant to authority vested in the Department of Industry, Labor and Human Relations by section(s) 101.02, 101.14 and 101.575, Stats., the Department of Industry, Labor and Human Relations creates; amends; repeals and recreates; repeals and adopts rules of Wisconsin Administrative Code chapter (s):

ILHR 14 (Number) General Hazard Fire Prevention (Title)

The attached rules shall take effect on the first day of the month following publication in the Wisconsin Admin. Register pursuant to section 227.22, Stats.

Adopted at Madison, Wisconsin, this

date: December 20, 1988

DEPARTMENT OF INDUSTRY, LABOR AND HUMAN
RELATIONS

John Coughlin
Secretary



RULES in FINAL DRAFT FORM

Rule: Chapter ILHR 14 (Formerly Ch. Ind 65)

Relating to: General Hazard Fire Prevention Code

Clearinghouse Rule No.: 87-156

The Wisconsin Department of Industry, Labor and Human Relations proposes an order to repeal Ch. Ind 65; and to create Ch. ILHR 14, relative to general hazard fire prevention in public buildings and places of employment.

* * * * *

ANALYSIS OF PROPOSED RULES

Section 101.14, Stats., establishes the authority of the Department and local fire departments relative to fire inspections, prevention, detection and suppression in public buildings and places of employment. Under that section, the fire chief of each fire department in the state is an authorized deputy of Department and is required to conduct fire prevention inspections on public buildings and places of employment on a periodic basis.

Currently, the administrative rules utilized in the making of the required fire prevention inspections are included in various chapters of the Wisconsin Administrative Code. Those codes include the following:

1. Chapter ILHR 11 - Liquefied Petroleum Gases Code;
2. Chapter ILHR 12 - Liquefied Natural Gas Code;
3. Proposed Chapter ILHR 13 - Compressed Natural Gas Code;
4. Chapter ILHR 15 - Cleaning and Dyeing Code;
5. Chapters ILHR 50-64 - Building and Heating, Ventilating and Air Conditioning Code;
6. Chapter Ind 8 - Flammable and Combustible Liquids; and
7. Chapter Ind 65 - Fire Prevention Code.

The purpose of proposed chapter ILHR 14 is to provide a comprehensive single fire prevention code for use by local fire department inspectors in conducting fire prevention inspections in public buildings and places of employment.

In developing the proposed rules, the department utilized the model fire prevention codes (Uniform Fire Code, Southern Standard Fire Code, BOCA Basic/National Fire Code) and various standards of the National Fire Protection Association as the basis for the regulations. The topical outline of the BOCA Basic/National Fire Prevention Code was utilized as the basis for the rules. The regulations of each of the three model fire codes and the applicable NFPA Standards were reviewed and compared and then utilized as a basis for the proposed rules.

The proposed rules repeal chapter Ind 65 and incorporate by cross-reference a significant number of sections from the Wisconsin Administrative Building and Heating, Ventilating and Air Conditioning Code (chapters ILHR 50 to 64). The proposed rules also cross-reference appropriate statutory sections dealing with various fire prevention and protection topics. In those instances where current administrative rule or statutory language is cross-referenced, the language of the cross-reference material is incorporated in the Appendix of the proposed code. In this various manner, the Department can easily update chapter ILHR 14 when those sections of the administrative rules or the statutes are changed. Since the material is contained in the Appendix for information purposes only, the text can be updated without required rulemaking procedures as specified in chapter 227, Stats.

The proposed rules are contained in 34 topical subchapters. Further explanatory material and reprints of cross-reference material is included in the Appendix of the Code. The proposed rules address the general issues of:

1. Administration and enforcement;
2. General precautions against fire;
3. Building components and construction;
4. Fire protection systems;
5. Means of egress; and
6. Various subchapters dealing with a variety of materials and building uses/occupancies.

The rules, as proposed, would apply to both new and existing public buildings and places of employment.

Based upon public hearing input, proposed rules relating to fire department access, fire division walls and proposed changes to the Building Code have been withdrawn from this package and referred to appropriate Building Code citizen advisory committees for additional research and joint consideration for the Building Code and Fire Prevention Code Committees. Once finalized, these rules will be again subjected to public hearing.

The entire proposal has been reviewed and endorsed for public hearing by the General Fire Hazards Subcommittee of the Wisconsin Fire Prevention Council and the full Fire Prevention Council. The membership of the subcommittee and council are as follows:

GENERAL FIRE HAZARDS SUBCOMMITTEE

Jeffrey Amo, Wisconsin Fire Inspectors Association

John R. Bingham, Professional Fire Fighters of Wisconsin

Paul Bodeau, Wisconsin Manufacturers and Commerce Association

Ed Ciechanowski, League of Wisconsin Municipalities

Rex Colvin, Bureau of Petroleum Inspection and Fire Prevention, DILHR

Carl F. Kearns, Wisconsin State Fire Chiefs Association

Daniel Murray, Bureau of Buildings and Structures, DILHR

Frank Reisenauer, Wisconsin State Fire Chiefs Association

WISCONSIN FIRE PREVENTION COUNCIL

Jeffrey Amo, Wisconsin Fire Inspectors Association

David Berenz, Wisconsin AFLCIO

Edward M. Ciechanowski, Wisconsin Building Inspector Association/
Wisconsin League of Municipalities

Kingsley Forbes, Wisconsin LP Gas Association

Charles A. Hawk, Wisconsin Manufacturers and Commerce Association

James Jarapko, Professional Fire Fighters of Wisconsin

Karl F. Kearns, Wisconsin State Fire Chiefs Association

James H. McLaughlin, Wisconsin Chapter, Society of Fire Protection Engineers

Philip McManus, Oil Jobbers of Wisconsin Incorporated

Marvin Mundt, Insurance Industry

Charles Elliott, Wisconsin Petroleum Council

GERMANE MODIFICATIONS

In addition to the changes, additions and deletions to the Draft made in response to public hearing input and Legislative Council comments, germane modifications have also been added in response to recently enacted legislation.

The Department had suggested changes to the current laws dealing with the definition of the term "fire department" and the 2% Fire Dues program. These changes were developed by the 2% Fire Dues Subcommittee of the Wisconsin Fire Prevention Council and were intended to eliminate archaic language in the statutes and to recognize public fire education efforts as a partial alternate to the mandated fire prevention inspections for 2% fire dues eligibility. These changes were inserted in the budget bill by Senator Adelman and became part of 1987 Wisconsin Act 399.

The public fire education related rules were inserted in s. ILHR 14.021. Administrative rules regarding fire department equipment and written records previously developed by the Fire Prevention Council and mandated in the Budget Law were inserted in ss. ILHR 14.023 and 14.022, respectively. Including these changes prior to legislative committee review and approval will fulfill the Department's rulemaking mandates of the Budget Law without the need for additional public hearings.

The Legislature also passed a bill which became 1987 Wisconsin Act 288. This law deals with the frequency of fire prevention inspections required in cities of the first class (Milwaukee). Language to reflect the intent and letter of this law was inserted in s. ILHR 14.020 (2) (d) 1.

Pursuant to the authority vested in the State of Wisconsin's Department of Industry, Labor and Human Relations by ss. 101.02 (1), 101.02 (15) (h) to (j), 101.14 (1) (a), 101.14 (2) (cm) 3. and 101.575 (3) (a) 5. and 7., Stats., the Department hereby repeals and creates rules interpreting ss. 101.02 (15) (h) to (j), 101.14 (1) (a), 101.14 (2) (c) 2., 101.14 (2) (cm) 3. and 101.575 (3) (a) 5. and 7., Stats., as follows:

3064k

Chapter ILHR 14
General Hazard Fire Prevention

Table of Contents

<u>SECTION NO.</u>	<u>TOPIC</u>	<u>PAGE NO.</u>
<u>Subchapter I - Purpose and Scope</u>		
14.001	Purpose	1
14.002	Scope	1
<u>Subchapter II - Definitions</u>		
14.010	Definitions	3
<u>Subchapter III - Administration and Enforcement</u>		
14.020	Duties of the Fire Department	5
14.021	Public Fire Education - Related Activities	6a
14.022	Recordkeeping	7
14.023	Equipment	7
14.024	Local Regulations	8
14.025	Revocation of Approval	8
14.026	Appeals	8
14.027	Petition for Variance	8
14.028	Penalties	8
14.029	Adoption of Standards by Reference	9
<u>Subchapter IV - General Precautions Against Fire</u>		
14.100	Open Burning	9
14.101	Bonfires	11
14.102	Kindling of Fire	11
14.103	Handling of Burning Material	11
14.104	Hot Ashes and Other Dangerous Materials	11
14.105	Incinerators	12
14.106	Use of Incinerators Prohibited	12
14.107	Miscellaneous Use of Torches and Welding Equipment	12
14.108	Asphalt Kettles	12
14.109	Accumulation of Waste	13
14.110	Handling and Storage of Combustible Materials	13
14.111	Packing Material	14
14.112	Chemically Soiled Wastes	14
14.113	Cleanliness	14
14.114	Prohibition of Smoking	15
14.115	Open Flame or Light	15
14.116	Matches	16
14.117	Dilapidated or Vacant Buildings	16
14.118	Extension Cords	17

<u>SECTION NO.</u>	<u>TOPIC</u>	<u>PAGE NO</u>
	<u>Subchapter V - Building Components and Construction</u>	
14.119	Chimneys and Heating Appliances	18
14.120	Service Equipment Areas	19
14.121	Interior Finishes and Flammable and Decorative Materials	19
14.122	Fire Resistive Construction and Components	20
	<u>Subchapter VI - Fire Protection Systems</u>	
14.123	General Requirements	21
14.124	Automatic Fire Sprinkler Systems	21
14.125	Standpipe Systems	21
14.126	Manual Fire Alarm Systems	21
14.127	Smoke Detection Systems, Heat Detection Systems, Smoke Detectors and Heat Detectors	21
14.128	Portable Fire Extinguishers	21
14.129	Other Fire Safety Devices	22
14.130	Test Records	22
14.131	Unsafe Buildings	22
14.132	Buildings Under Construction	22
14.133	Vacant Buildings	23
14.134	Buildings Under Demolition	23
	<u>Subchapter VII - Means of Egress</u>	
14.135	General Requirements	23
	<u>Subchapter VIII - Flammable and Combustible Liquids</u>	23
	<u>Subchapter IX - Oil Burning Equipment</u>	23
	<u>Subchapter X - Organic Coatings</u>	23
	<u>Subchapter XI - Hazardous Materials and Chemicals</u>	24
	<u>Subchapter XII - Application of Flammable Finishes</u>	24
	<u>Subchapter XIII - Service Stations and Garages</u>	24

<u>SECTION NO.</u>	<u>TOPIC</u>	<u>PAGE NO.</u>
	<u>Subchapter XIV - Liquefied Petroleum Gases</u>	24
	<u>Subchapter XV - Liquefied Natural Gas</u>	24
	<u>Subchapter XVI - Compressed Natural Gas</u>	24
	<u>Subchapter XVII - Public Buildings and Places of Employment</u>	
14.136	General Requirements	24
	<u>Subchapter XVIII - Bowling Establishments</u>	
14.137	Permit Required	24
14.138	Prior Notification	24
14.139	Prohibitions During Lane Resurfacing Operations	24
14.140	Ventilation	25
14.141	Waste Materials	25
14.142	Pin Refinishing	25
	<u>Subchapter XIX - Tents and Air Supported Structures</u>	
14.143	General Requirements	25
14.144	Parking of Vehicles	25
14.145	Location of Air-Supported Structures and Tents	26
14.146	Flame Retardant Treatment	26
14.147	Smoking and Open Flame	26
14.148	Fire Extinguishers and Other Fire Protection Equipment	27
14.149	Abatement of Special Fire or Panic Hazards	27
14.150	Flammable and Combustible Liquids	27
14.151	Housekeeping	27
	<u>Subchapter XX - Dry Cleaning Plants</u>	28
	<u>Subchapter XXI - Lumber Yards</u>	
14.152	Permit Required	28
14.153	Open Yard Storage and Driveways	28
14.154	Fences	28
14.155	Operational Fire Hazards	28
14.156	Smoking Prohibited	28
14.157	Yards	28
14.158	Removal of Debris	28
14.159	Fire Extinguishing Equipment	29

<u>SECTION NO.</u>	<u>TOPIC</u>	<u>PAGE NO.</u>
<u>Subchapter XXII - Woodworking Plants</u>		
14.160	Refuse Removal	29
14.161	Fire Protection	29
<u>Subchapter XXIII - Vehicle Tire Rebuilding Plants</u>		
14.162	Permit Required	29
14.163	Dust Collection	29
14.164	Ventilation	29
<u>Subchapter XXIV - Fireworks</u>		30
<u>Subchapter XXV - Explosives, Ammunition & Blasting</u>		30
<u>Subchapter XXVI - Magnesium</u>		
14.165	Permit Required	30
14.166	Storage of Magnesium	30
14.167	Handling of Magnesium	30
14.168	Fire Safety Requirements	32
<u>Subchapter XXVII - Cryogenic Liquids</u>		
14.169	Definitions	32
14.170	Permit Required	32
14.171	Containers and Equipment	32
14.172	Fire Safety Requirements	33
14.173	Transportation	33
<u>Subchapter XXVIII - Welding, or Cutting, Calcium Carbide and Acetylene Generators</u>		
14.174	General	33
<u>Subchapter XXIX - Cellulose Nitrate Motion Picture Film</u>		
14.175	Permit Required	33
14.176	Projection Booths	33
<u>Subchapter XXX - Cellulose Nitrate Plastics</u>		
14.177	Permit Required	34
14.178	Fire Safety Requirements	34

SECTION NO. TOPIC PAGE NO.

Subchapter XXXI - Combustible Fibers

14.179	Scope	34
14.180	Permit Required	34
14.181	Storage	34
14.182	Special Baling Conditions	35

Subchapter XXXII - Dust Explosion Hazards

14.183	Permit Required	35
14.184	General Requirements	35
14.185	Fire Safety Requirements	36

Subchapter XXXIII - Crop Ripening or Coloring Processes

14.186	Permit Required	36
14.187	Fire Safety Requirements	36

Subchapter XXXIV - Fumigation and Thermal Insecticidal Fogging

14.188	Scope	37
14.189	Definitions	37
14.190	Permit Required	38
14.191	Fire Safety Requirements	38

APPENDIX

A14.002	Exempt Buildings	40a
A14.020	Fire Inspection Reporting Form	40a
A14.020	Written Fire Reports	41
A14.023	Equipment	44a
A14.027	Petition for Variance	45
A14.Various	Permits	47a
A14.102	Kindling of Fire	48
A14.103	Handling of Burning Material	48
A14.105	Incinerators	49
A14.110	Storage Areas-Auto. Fire Sprinkler System Protection	49h
A14.110	Clearances to Electrical Equipment	49h
A14.110	Outside Storage	51
A14.114	Prohibition of Smoking	51
A14.115	Matches	52
A14.117	Dilapidated or Vacant Buildings	54
A14.119	Chimneys and Heating Appliances	59
A14.119	Food Preparation Equipment	65
A14.121	Interior Finishes and Flammable and Decorative Materials	67
A14.122	Fire Resistive Construction and Components	72

<u>SECTION NO.</u>	<u>TOPIC</u>	<u>PAGE NO.</u>
A14.123	Fire Prevention, Detection and Protection Systems	78
	Standpipe and Hose Systems	79
	Fire Extinguishers	83
	Automatic Fire Sprinklers	83
	Fire Alarm Systems	85
	Smoke Detectors	86A
A14.124	Automatic Fire Sprinkler Systems - Maintenance	87
A14.125	Standpipe Systems - Maintenance	108
A14.126	Manual Fire Alarm Systems - Maintenance	110
A14.127	Smoke Detection Systems and Heat Detection Systems	121
	NFPA No. 72E - Maintenance	122
	NFPA No. 74 - Maintenance	125
A14.128	Portable Fire Extinguishers - Maintenance	127
A14.135	Means of Egress	133
	General	134
	Ch. ILHR 54 Buildings	148
	Ch. ILHR 55 Buildings	153
	Ch. ILHR 56 Buildings	158
	Ch. ILHR 57 Buildings	163
	Ch. ILHR 58 Buildings - Health Care	168
	Ch. ILHR 58 Buildings - Places of Detention	176
	Ch. ILHR 59 Buildings	182
	Ch. ILHR 60 Buildings - General	186
	Ch. ILHR 60 Buildings - 4 to 8	188
	Ch. ILHR 60 Buildings - 9 or More	190
	Ch. ILHR 61 Buildings	193
	Ch. ILHR 62 Buildings - Open Parking Structures	196
	Ch. ILHR 62 Buildings - Tents	198
	Ch. ILHR 62 Buildings - Assembly Seating	200
	Ch. ILHR 62 Buildings - Greenhouses	204
	Ch. ILHR 62 Buildings - Pedestrian Access Structures	206
A14.143	Tents and Air Supported Structures	207a
A14.159	Lumber Yards - Fire Extinguishing Equipment	207d
A14.161	Woodworking Plants - Fire Protection	207d
A14.174	Welding or Cutting, Calcium Carbide and Acetylene	208
A14.176	Projection Booths	222

SECTION 1. Ch. Ind 65 is repealed.

SECTION 2. Ch. ILHR 14 is created to read:

CHAPTER ILHR 14
GENERAL HAZARD FIRE PREVENTION

Subchapter I - Purpose and Scope

ILHR 14.001 PURPOSE. The purpose of this chapter is to protect the health, safety and welfare of the public and employes by establishing minimum standards for the prevention of fire.

ILHR 14.002 SCOPE. (1) GENERAL. The provisions of this chapter shall apply to all public buildings and places of employment.

(2) EXEMPT BUILDINGS. The following buildings and uses are not public buildings or places of employment and are not subject to the provisions of this chapter:

(a) One- and 2-family dwellings and outbuildings in connection with the dwellings, including but not limited to, barns and private garages;

(b) Buildings used exclusively for farming as specified in s. 102.04 (3), Stats.;

Note: A reprint of s. 102.04 (3), Stats., is included in the Appendix.

(c) Buildings used primarily for housing livestock or for other agricultural purposes, located on research or laboratory farms of public universities or other state institutions;

(d) Temporary buildings, used exclusively for construction purposes, not exceeding 2 stories in height, and not used as living quarters;

(e) Buildings located on Indian reservation land held in trust by the United States;

(f) Buildings owned by the federal government. Buildings owned by other than the federal government and leased to the federal government are not exempt;

(g) Bed and breakfast establishments;

(h) Community-based residential facilities located in existing buildings and providing care, treatment and services to 3 to 8 unrelated adults; and

(i) Rural school buildings.

(3) RETROACTIVITY. (a) Except as provided in par. (b), the provisions of this chapter shall apply to all public buildings and places of employment, whenever constructed before, on or after the effective date of this section...[Revisor inserts date].

(b) 1. The provisions of par. (a) do not apply to those sections where the text of that section specifically excludes retroactive application of that section.

2. Those sections of this code which cross reference sections of other Wisconsin administrative code chapters shall be applied as specified in the scope and application provisions of the chapter which is cross referenced.

Note #1: For example, the scope and application provisions of the Wisconsin Administrative Building and Heating, Ventilating and Air Conditioning Code, chs. ILHR 50-64, indicate that the building must be constructed and maintained in accordance with the code in effect at the time of construction. Subsequent alterations, remodeling or additions must conform to the code in current effect at the time of their construction.

Note #2: The following sections of ch. ILHR 14 cross reference other Wisconsin administrative code chapters and should be retroactively applied as specified in Note #1:

- Sections ILHR 14.110 (2) (c)
- 14.111 (2)
- 14.119 (1)
- 14.120 (3)
- 14.121
- 14.122
- 14.123
- 14.124
- 14.126
- 14.127
- 14.128
- 14.135
- Subchapters VIII
- IX
- X
- XI
- XII
- XIII
- XIV
- XV
- XVI
- XVII
- Sections ILHR 14.143 (1)
- 14.150 (2) (3)
- Subchapters XX
- XIV
- XXV
- Sections ILHR 14.176
- 14.187 (2), (3) (e)
- 14.191 (2)

(4) APPLICATION. Where different sections of this chapter specify different requirements, the most restrictive requirement shall govern.

Subchapter II - Definitions

ILHR 14.010 DEFINITIONS. In of this chapter, the following definitions shall apply:

(1) "Approved" means acceptable to the department or to the fire department having jurisdiction in that order.

(1a) "Automatic fire sprinkler system", means an integrated system of underground and overhead piping for fire protection purposes, designed in accordance with fire protection engineering standards. The system includes a suitable water supply, such as a gravity tank, fire pump, reservoir or pressure tank or connection beginning at the supply side of an approved gate valve located at or near the property line where the pipe or piping system provides water used exclusively for fire protection and related appurtenances and to standpipes connected to automatic sprinkler systems. The portion of the sprinkler system above ground is a network of specially sized or hydraulically designed piping installed in a building, structure or area, generally overhead, and to which sprinklers are connected in a systematic pattern. The system includes a controlling valve and a device for actuating an alarm when the system is in operation. The system is usually activated by heat from a fire and discharges water over the fire area.

(1b) "Automatic fire suppression system", means a mechanical system designed and equipped to detect a fire, actuate an alarm and suppress or control a fire using water, water spray, foam, carbon dioxide, halogenated agent or other approved suppression agent.

(2) "Bed and breakfast establishment", as defined in s. 50.50 (1), Stats., means any place of lodging that provides 4 or fewer rooms for rent, is the owner's personal residence and is occupied by the owner at the time of rental.

(3) "Bonfire" means a large open-air fire kindled to mark a public event, victory celebration or similar occurrence where dry, combustible material such as wood, paper and similar items are burned.

(3m) "Building" or "Structure" means a public building or place of employment.

(4) "Department" means the department of industry, labor and human relations.

(5) "Existing" means completed or in use or occupied prior to the effective date of applicable rules of this chapter.

(6) "Fire chief" means the chief or authorized representative of the fire department serving the unit of government having authority over the public building or place of employment.

(7) "Labeled" means a label, symbol or other identifying mark of a nationally recognized testing laboratory, inspection agency, or other organization concerned with product evaluation, that maintains periodic inspection of production of labeled equipment or materials and whose labeling indicates compliance with nationally recognized standards or tests to determine suitable usage in a specified manner.

(8) "Listed" means included in a list published by a nationally recognized testing laboratory, inspection agency, or other organization concerned with product evaluation, that maintains periodic inspection of production of listed equipment or materials and whose listing states either that the equipment or material meets nationally recognized standards or has been tested and found suitable for use in a specified manner.

(9) "Open burning" means a controlled, limited size open-air fire except for outdoor cooking, campfires, land clearing, fire department training and similar purposes.

(10) "Permit" means written approval or written acceptance by the department, fire chief or local authority having jurisdiction.

(11) "Place of abode" means a residential building or part of a residential building used as follows:

(a) Occupied as a residence by 3 or more families living independently or occupied by 2 such families and used also for business purposes; or

(b) Occupied for sleeping or lodging purposes by 3 or more persons not members of the same family.

Note: Examples of places of abode include, but are not limited to, apartment buildings, garden apartments, row houses, town houses, condominiums, hotels, motels, rooming houses, dormitories, convents, monasteries, homes for the aged and certain community-based residential facilities.

(12) "Place of employment" means every place, whether indoors or out or underground and the premises appurtenant thereto where either temporarily or permanently any industry, trade or business is carried on, or where any process or operation, directly or indirectly related to any industry, trade or business, is carried on, and where any person is, directly or indirectly, employed by another for direct or indirect gain or profit, but does not include any place where persons are employed in private domestic service which does not involve the use of mechanical power or in farming.

(13) "Public building" means any structure, including exterior parts of such building, such as a porch, exterior platform or steps providing means of ingress or egress, used in whole or in part as a place of resort, assemblage, lodging, trade, traffic, occupancy, or use by the public or by 3 or more tenants.

(14) "Residential occupancy" means places of abode used for sleeping purposes and including, but not limited to, apartment buildings, garden apartments, row houses, town houses, condominiums, hotels, motels, rooming houses, dormitories, convents, monasteries, homes for the aged, sheltered facilities for battered women, as specified in s. 46.95, Stats., serving more than 20 occupants, community-based residential facilities serving 9 or more unrelated adults, and community-based residential facilities located in existing buildings and serving more than 20 unrelated adults.

(15) "Rural school building" means a building that is used solely for instructional purposes, is located outside of the corporate limits of a city or village, is not more than one story in height and contains not more than 2 classrooms.

Subchapter III - Administration and Enforcement

ILHR 14.020 DUTIES OF THE FIRE DEPARTMENT. (1) AUTHORIZED DEPUTY OF THE DEPARTMENT. The fire chief of the fire department in every city, village or town, except cities of the first class, is a duly authorized deputy of the department.

(2) FIRE PREVENTION INSPECTIONS. (a) General. The chief of the fire department shall be responsible for having all public buildings and places of employment inspected by officers or members of the fire department for the purpose of ascertaining and causing to be corrected any conditions liable to cause fire, or any violations of any law or ordinance relating to fire hazards or to the prevention of fires.

(b) Determining the number of buildings to be inspected. 1. The fire chief shall be responsible for determining the number of public buildings and places of employment to be inspected for each municipality for which the fire department has responsibility.

2. The fire chief shall submit to the department, by January 15th of each year, the number of public buildings and places of employment to be inspected for the municipality.

a. The list shall identify the number of public buildings and places of employment by municipality.

b. The list shall identify the number of public buildings and places of employment located within locally established fire limits or congested districts subject to conflagration and those public buildings and places of employment located outside of locally established fire limits or congested districts subject to conflagration.

(c) Scheduling of inspections. 1. Except as provided in par. (d), fire prevention inspections shall be conducted as follows:

1. Fire prevention inspections shall be conducted at least once every 6 months, or more often if ordered by the chief of the fire department, in all territory served by the fire department. Each 6-month period shall begin on January 1 and July 1.

2. Fire prevention inspections in territories designated by a local authority to be within the fire limits or as a congested district subject to conflagration shall be conducted at least once every 3 months, or more often if ordered by the chief of the fire department. Each 3-month period shall begin on January 1, April 1, July 1, and October 1.

(d) Exceptions. 1. a. In 1st class cities, the fire chief may establish the schedule of fire inspections in that city.

b. The fire chief shall base the frequency of the inspections on hazardous classification, the proportion of public area, the record of fire code violations, the ratio of occupancy to size and any other factor the chief deems significant.

c. Property other than residential property with 4 dwelling units or less shall be inspected at least once annually.

2. A fire department need not conduct all of the inspections specified in par. (c) providing all of the following conditions are satisfied:

- a. At least 80% of the total required fire prevention inspections specified in par. (c) are completed;
- b. At least 50% of the required number of fire prevention inspections specified in par. (c) for each public building and place of employment occupancy subject to inspection are completed; and
- c. Public fire education services as specified in s. ILHR 14.021 are provided.

(e) Written reports. 1. Written reports of inspections shall be made and kept on file in the office of the chief of the fire department in the manner and form required by the department.

Note #1: See Appendix for a copy of the fire inspection reporting form (SBD-7959) which is available from the department. The use of other fire inspection reporting forms is permitted subject to approval of the department.

Note #2: The department is participating in the National Fire Incidence Reporting System (NFIRS), and all fire departments are encouraged to submit fire incidence reports to the department on NFIRS forms provided by the department. See Appendix for a reproduction of the NFIRS form.

2. Written fire incidence reports shall be submitted to the department at least annually. The reports shall be submitted to and received by the department no later than January 15 for the previous year.

Note: It is recommended that fire incidence reports be submitted monthly to facilitate the processing of the reports and the preparation of the annual state Fire Statistics Report.

ILHR 14.021 PUBLIC FIRE EDUCATION - RELATED ACTIVITIES. Fire departments may reduce the number of fire prevention inspections conducted as specified in s. ILHR 14.020 (2) (d) 2. provided the fire department completes at least 4 of any of the following 11 public fire education related activities:

(1) FIRE PREVENTION TRAINING. All fire department personnel directly involved in conducting fire inspections shall certified by the department and by the fire chief upon completion of required training approved by the department and by the fire chief;

(2) FIRE PREVENTION WEEK PROGRAM. Fire departments shall complete at least 3 of the following activities during national fire prevention week: children's poster contest; fire department open house; school visits to teach children fire safety; fire department fire safety demonstrations, such as but not limited to fire fighting demonstrations, fire extinguisher and smoke detector demonstrations, "stop/drop/roll" demonstrations; or one activity that specifically ties in with the national fire prevention week theme;

(3) RESIDENTIAL FIRE INSPECTION PROGRAM. Fire departments shall advertise and conduct residential fire inspections on a request basis or in response to local ordinance;

(4) BUILDING PLAN REVIEW PROGRAM. Fire departments shall conduct plan reviews prior to construction of public buildings and places of employment;

(5) SCHOOL EDUCATION PROGRAM. Fire departments shall conduct approved fire safety education programs in the school districts for which they have responsibility;

(6) CONTINUING PUBLIC FIRE EDUCATION PROGRAM. Fire departments shall conduct public fire education programs. Fire departments may not utilize activities specified in subpar. b. for this program. At least 12 programs per year shall be conducted over a minimum 8-month period. No more than two programs may be conducted in any one month. The programs may include monthly public service announcements for radio or television, monthly newspaper articles, booth at fairs, demonstrations at shopping centers, billboards with fire safety messages and similar activities acceptable to the department;

(7) PUBLIC FIRE EDUCATION SPEAKING BUREAU. Fire departments shall organize a group of speakers to make public fire education presentations to civic organizations, professional organizations, school organizations and similar groups. At least 4 presentations per year shall be given;

(8) YOUTH FIRE AWARENESS PROGRAM. Fire departments shall conduct youth fire awareness programs including but not limited to skill award and merit badge clinics for scouts, junior fire marshall program, juvenile fire starter program, first aid and CPR training and related activities;

(9) FIRE EXTINGUISHER TRAINING PROGRAM. Fire departments shall conduct at least two training programs for the public or industry regarding the operation of fire extinguishers. Industrial fire brigade training programs may be conducted to complete this requirement.

(10) OCCUPANCY INSPECTION PROGRAM. Fire departments shall conduct inspections of public buildings and places of employment prior to the issuance of local occupancy permits. Written documentation of the inspections shall be kept as specified in s. 101.575 (3)(a) 5.b.; or

(11) SMOKE DETECTOR AWARENESS PROGRAM. Fire departments shall conduct at least four programs per year to inform people regarding the effectiveness and proper installation of smoke detectors in residential buildings, public buildings and places of employment.

ILHR 14.022 RECORDKEEPING. (1) GENERAL. The following records shall be generated and maintained by each fire department:

- (a) Current roster of active fire department members;
- (b) Date and location of the fire prevention inspections conducted, violations found and corrective actions taken.
- (c) Time, date and location of fires, and number of fire department members responding;
- (d) Number and duration of, and attendance at, fire department meetings;
- (e) Number and duration of, topic of and attendance at fire department training sessions; and
- (f) Number, type, and duration of and attendance at public fire education related activities;

(2) AVAILABILITY OF RECORDS. The records specified in sub. (1) shall be kept at the fire station and shall be made available upon request to the fire department.

ILHR 14.023 EQUIPMENT. Pursuant to s. 101.575 (3) (a) 7., Stats., each fire department shall maintain at least the following equipment:

- (1) At least one 150-foot length of 1-1/2 inch preconnected hose, or the equivalent, with a nozzle capable of discharging either a fog or a straight stream;
- (2) Two portable fire extinguishers, suitable for use on Class A, B and C fires. The minimum size of each extinguisher shall be 20BC rating in dry chemical, 10BC rating in carbon dioxide or 2A rating in water-type extinguishers;
- (3) One 12-foot ladder with folding hooks;
- (4) One 24-foot extension ladder;
- (5) One pick-head axe;
- (6) Two electric lanterns;
- (7) One pike pole;
- (8) One bolt cutter;
- (9) One claw tool; and
- (10) One crowbar.

Note: See s. 101.575 (3) (a) for additional requirements pertaining to fire departments. A copy of s. 101.575 (3) (a) is reprinted in the index.

ILHR 14.024 LOCAL REGULATIONS. This chapter shall not limit the power of cities, villages and towns to make, or enforce, additional or more stringent regulations, provided the regulations do not conflict with this chapter or with any other rule of the department, or law.

ILHR 14.025 REVOCATION OF APPROVAL. The department or authority having jurisdiction, may revoke any approval, issued under the provisions of this chapter, for any false statements or misrepresentation of facts on which the approval was based.

ILHR 14.026 APPEALS. Any person affected by any local order as defined in s. 101.01 (1) (g), Stats., which is in conflict with a rule of the department may petition the department for a hearing on the ground that the local order is unreasonable or in conflict with the rule of the department or both.

Note: Section 101.01 (1) (g), Stats., defines "local order" as any ordinance, order, rule or determination of any common council, board of aldermen, board of trustees or the village board, of any village or city, or the board of health of any municipality, or an order or direction of any official of such municipality, upon any matter over which the department has jurisdiction.

ILHR 14.027 PETITION FOR VARIANCE. (1) PROCEDURE. The department shall consider and may grant a variance to a provision of this chapter upon receipt of a fee, a completed petition for variance form from the owner, and a position statement from the fire department having responsibility and an interest in the provision, provided an equivalency is established in the petition for variance which meets the intent of the provision being petitioned. The department may impose specific conditions in a petition for variance to promote the protection of the health, safety or welfare of the employes or the public. Violation of those conditions under which the petition for variance is granted constitutes a violation of the provision.

Note #1: See Appendix for an example of the petition for variance (form SB-8) and the fire department position statement (form SB-8A).

Note #2: Section 101.02 (6), Stats., and ch. ILHR 3 outline the procedure for submitting petitions to the department and the department procedures for hearing petitions.

(2) PETITION PROCESSING TIME. Except for priority petitions, the department shall review and make a determination on a petition for variance within 30 business days of receipt of all calculations, documents and fees required to complete the review. The department shall process priority petitions within 10 business days.

ILHR 14.028 PENALTIES. Penalties for violations of this chapter shall be assessed in accordance with s. 101.02, Stats.

Note #1: Section 101.02 (13) (a), Stats., indicates penalties will be assessed against any employer, employe, owner or other person who fails or refuses to perform any duty lawfully enjoined, within the time prescribed by the department, for which no penalty has been specifically provided, or who fails, neglects or refuses to comply with any lawful order made by the department, or any judgment or decree made by any court in connection with ss. 101.01 to 101.25. For each such violation, failure or refusal, such employe, owner or other person must forfeit and pay into the state treasury a sum not less than \$10 nor more than \$100 for each violation.

Note #2: Section 101.02 (12), Stats., indicates that every day during which any person, persons, corporation or any officer, agent or employe thereof, fails to observe and comply with an order of the department will constitute a separate and distinct violation of such order.

ILHR 14.029 ADOPTION OF STANDARDS BY REFERENCE. (1) CONSENT TO INCORPORATE. Pursuant to s. 227.21, Stats., the attorney general and the revisor of statutes have consented to the incorporation by reference of the following standards of the National Fire Protection Association:

(a) NFPA No. 14-1986 - Standard for Standpipes and Hose Systems, Ch. 8 - Tests and Inspections.

(b) NFPA No. 37-1984 - Standard for Stationary Combustion Engines and Gas Turbines.

(c) NFPA No. 82-1983 - Standard on Incinerators, Waste and Linen Handling Systems and Equipment.

(d) NFPA No. 211-1984 - Standard for Chimneys, Fireplaces, Vents and Solid Fuel Burning Appliances.

(2) INTERIM AMENDMENTS. Interim amendments of a standard shall have no effect in the state until such time as this section is correspondingly revised to reflect those changes.

Note #1: Standards of the National Fire Protection Association may be obtained by writing to Publications Sales Department, National Fire Protection Association, Batterymarch Park, Quincy, Massachusetts 02269.

Note #2: Copies of the standards in reference are on file in the offices of the department, the secretary of state and the revisor of statutes.

Subchapter IV - General Precautions Against Fire

ILHR 14.100 OPEN BURNING. (1) PRIOR APPROVAL. (a) Except as provided in par. (b), all persons shall obtain authorization from the fire chief before kindling or maintaining any open burning or authorizing the kindling or maintaining of any open burning within the limits of any incorporated city or village.

(b) The following open burning shall be permitted without authorization from the fire chief:

1. Outdoor cooking;
2. Campfires; and
3. Training for fire departments.

Note: Burning outside the incorporated limits of cities and villages is regulated by the Department of Natural Resources under ch. NR 30 - Forest Fire Control and ss. 26.11 to 26.13, Stats.

(2) SIZE OF PILE. The size of the pile of material to be burned shall not exceed 4 feet by 4 feet by 3 feet high.

(3) LOCATION. The location of the open burning shall be approved by the fire chief and either:

(a) The pile of material being burned shall be at least 50 feet from any structure, wood or lumber pile, wooden fence, trees or bushes, and provisions shall be made to prevent the fire from spreading to within 50 feet of such items; or

(b) The fire shall be contained in an approved burner located at least 15 feet from any structure, wood or lumber pile, wooden fence, tree or bush.

(4) MATERIAL FOR BURNING. (a) Fuel for open burning shall consist of dry material only and shall not be ignited with flammable or combustible liquids.

(b) Material for open burning may not include rubbish, garbage, trash, any material made of or coated with rubber, plastic, leather or petroleum based materials and may not contain any flammable or combustible liquids.

(5) SUPERVISION. Open burning shall be constantly attended and supervised by a competent person at least 16 years of age until such fire is extinguished. This person shall have readily available for use fire extinguishing equipment deemed necessary by the fire chief.

(6) TIME OF BURN. Open burning shall be permitted only from 7:00 a.m. to 1/2 hour after sunset or as permitted by the fire department having jurisdiction.

(7) OTHER REGULATIONS. Open burning shall also be subject to the administrative rules of the department of natural resources and ordinances or regulations of the local authority having jurisdiction.

Note: See ch. NR 30 - Forest Fire Control and ss. 26.11 to 26.13, Stats., for regulations pertaining to burning in areas outside the incorporated limits of cities and villages.

(8) PROHIBITION. Outdoor burning shall be prohibited when the wind velocity exceeds 9 MPH or local circumstances make the fires potentially hazardous. Local circumstances include but are not limited to thermal inversions, ozone alerts, and very dry conditions.

Note: Outdoor burning may be prohibited by the Department of Natural Resources due to air quality considerations.

ILHR 14.101 BONFIRES. (1) PRIOR APPROVAL. All persons shall obtain authorization from the fire chief before kindling or maintaining any bonfire or authorizing the kindling or maintaining of any bonfire on any premises.

(2) QUANTITY OF MATERIAL TO BE BURNED. The allowable quantity of material to be burned shall be determined by the fire chief and shall be based upon the fire safety considerations of the situation and the desired duration of burn.

(3) MATERIAL FOR BURNING. (a) Fuel for bonfires shall consist of dry material only and shall not be ignited with flammable or combustible liquids.

(b) Material for bonfires may not include rubbish, garbage, trash, any material made of or coated with rubber, plastic, leather or petroleum based materials and may not contain any flammable or combustible liquids.

(4) OTHER REGULATIONS. Persons kindling or maintaining bonfires or authorizing the kindling or maintenance of bonfires shall be subject to the ordinances and regulations of the fire department having jurisdiction.

Note: See ch. NR 30 - Forest Fire Control and ss. 26.11 to 26.13, Stats., for regulations pertaining to burning in areas outside the incorporated limits of cities and villages.

ILHR 14.102 KINDLING OF FIRE. The kindling of fire shall comply with ss. 941.11, 943.02 and 943.03, Stats.

Note: See Appendix for reprint of ss. 941.11, 943.02 and 943.03, Stats.

ILHR 14.103 HANDLING OF BURNING MATERIAL. The handling of burning material shall comply with ss. 941.10 and 943.05, Stats.

Note: See Appendix for reprint of ss. 941.10 and 943.05, Stats.

ILHR 14.104 HOT ASHES AND OTHER DANGEROUS MATERIALS. (1) GENERAL. Except as provided in sub. (2), no person may deposit hot ashes or cinders, smoldering coals, or greasy or oily substances liable to spontaneous ignition, into any combustible receptacle or place these materials within 15 feet of any combustible materials.

(2) METAL OR NONCOMBUSTIBLE RECEPTACLES. Hot ashes or cinders, smoldering coals or greasy or oily substances liable to spontaneous ignition placed in metal or noncombustible, covered receptacles are exempt from the provisions of sub. (1), providing the following conditions are satisfied:

(a) The receptacle is resting upon a noncombustible floor or on the ground outside the building; or

(b) The receptacle is placed on a noncombustible stand; and

(c) The receptacle is kept at least 15 feet away from any combustible material, combustible wall or partition, exterior window opening, exit access or exit.

ILHR 14.105 INCINERATORS. Incinerators installed after the effective date of this section shall comply with the requirements of NFPA Standard 82 - Standard on Incinerators, Waste and Linen Handling Systems and Equipment and NFPA Standard 211 - Standard for Chimneys, Fireplaces, Vents and Solid Fuel Burning Appliances.

Note: See Appendix for partial reprint of NFPA Standard 211 pertaining to incinerators.

ILHR 14.106 USE OF INCINERATORS PROHIBITED. If the fire chief determines that burning in incinerators during periods of high fire hazard weather conditions will create an undue fire hazard, use of the incinerator shall be prohibited.

ILHR 14.107 MISCELLANEOUS USE OF TORCHES AND WELDING EQUIPMENT. (1) GENERAL. Any person using a torch or other flame-producing device for removing paint from any building or structure within the scope of this chapter or for sweating pipe joints, cutting, heat welding seams, thawing pipes, building construction or demolition shall provide at least one approved minimum 2-A water type fire extinguisher, minimum 4-A dry chemical type fire extinguisher, or minimum 1/2-inch diameter water hose connected to the water supply at the site where the burning is done.

Note #1: Also see Federal Occupational Safety and Health Administration regulations 29 CFR 1910, OSHA 2206, revised March 11, 1983 and chs. Ind 1000-2000 - Safety and Health Code for additional requirements.

Note #2: See s. ILHR 14.174 and A14.174 for additional rules pertaining to welding.

(2) ATTENDANCE. A firewatch shall be maintained in effect for at least 1/2 hour after each use of the torch or flame-producing device.

(3) ELECTRIC WELDING. The provisions of subs. (1) and (2) shall apply to the miscellaneous uses specified in sub. (1) of electric welding equipment.

ILHR 14.108 ASPHALT KETTLES. (1) TRANSPORTATION. An asphalt kettle may not be transported over any highway, road or street when the heating device for the kettle is operating.

(2) PROHIBITED LOCATIONS. (a) Subject to par. (b), an asphalt kettle may not be used inside of or on the roof of any building, unless the building is under construction.

(b) Asphalt kettles may be used on the roofs of buildings in excess of 60 feet in height when the building is being re-roofed or the roof is being repaired subject to the following conditions:

1. The asphalt kettle is taken to the roof outside the building;
2. All roof scuppers are closed during the roofing or repair operation;
3. The asphalt kettle is located on a noncombustible platform surface which is a minimum of 8 inches above the roof surface and which extends at least 2 feet beyond the exterior of the asphalt kettle; and
4. A source of water of at least 25 gallons per minute is available on the roof.

(3) FIRE EXTINGUISHERS. There shall be at least one approved fire extinguisher of a minimum 20-B:C classification within 30 feet of each asphalt kettle during the period such kettle is in use.

Note: See ch. ILHR 11 and NFPA Standard 58 for additional rules pertaining to LP-fired asphalt kettles.

ILHR 14.109 ACCUMULATION OF WASTE. (1) GENERAL. (a) Accumulations of litter or combustible or flammable waste may not be permitted to remain longer than 24 hours in any court, yard, vacant lot, alley, parking lot or open space unless in closed metal, noncombustible or other approved containers.

(2) VEGETATION. All weeds, grass, vines or other growth which endanger property, or are liable to be set afire, shall be cut down and removed.

(3) STORAGE WITHIN BUILDINGS. (a) All combustible rubbish or waste material not stored in approved covered, metal or noncombustible containers and not located in rooms of at least one-hour rated fire-resistive construction shall be removed from the building at least once every 24 hours.

(b) Oily waste and oily rags, when not in actual use, during work hours, shall be kept in approved, standard, self-closing metal waste cans, set firmly on 3-inch legs or approved noncombustible containers and located at least 10 feet from any combustible materials.

(4) NUISANCE OR HAZARD. Storage of waste may not produce conditions which in the opinion and judgment of the fire chief will tend to create a nuisance or a hazard to the public safety.

ILHR 14.110 HANDLING AND STORAGE OF COMBUSTIBLE MATERIALS. (1) HANDLING. No persons making, using, storing or having under their control any combustible packing materials and litter may fail or neglect at the close of each day to cause all material which is not compactly baled and stacked in an orderly manner to be removed from the building or stored in a single portable metal bin of a size for one day's supply; in metal-lined, covered portable receptacles or bins; or in a hazard enclosure as specified in s. ILHR 54.14.

(2) INSIDE STORAGE. (a) No persons may store in excess of 2500 cubic feet gross volume of combustible empty packing cases, boxes, barrels or similar containers, or rubber or cork, or other similarly combustible material without a permit from the fire chief.

(b) Combustible storage in buildings shall be orderly, shall be more than 2 feet from the ceiling, and shall be so located as not to endanger exit from the building.

Note: In areas protected by automatic fire sprinkler systems, refer to NFPA Standard No. 13 for proper clearances to sprinkler heads. See Appendix for reprint of s. 4-2.5.1. of NFPA Standard 13.

(c) Clearances between combustible materials and electric equipment shall be as specified in Section 110.16 of the National Electric Code as adopted in ch. ILHR 16.

Note: See Appendix for reprint of Section 110.16 of the NEC.

(3) OUTSIDE STORAGE. (a) Outside storage shall be so located as not to constitute a hazard to adjacent buildings or property and shall be compact and orderly.

(b) Individual piles shall not exceed 20 feet in height and shall be located at least 30 feet from buildings and to provide at least 15 foot wide driveways between piles.

(c) Driveways shall be so spaced that a maximum grid system unit of 50 feet by 150 feet is provided.

Note: See Appendix for diagram of acceptable sample layout of piles and driveways.

(d) Outside storage shall be prohibited within 3 feet of any property line and may not exceed 6 feet in height when within 15 feet of such property line, except where no hazard or menace of fire to adjoining property is created.

(e) Storage or accumulation of combustible waste matter, which constitutes a hazard or menace of fire, shall be removed within 24 hours.

ILHR 14.111 PACKING MATERIAL (1) GENERAL. The owner of a public building or place of employment in which shavings, sawdust, chips, excelsior, straw, plastics, or similar light combustible material is used for packing, shipping or manufacturing purposes, shall provide a minimum 2-hour rated fire-resistive enclosure of a capacity to contain all packing material.

(2) PROTECTION OF OPENINGS. Any opening into the enclosure specified in sub. (1) shall be protected by self-closing, fire-rated door assemblies as specified in s. ILHR 51.047.

(3) STORAGE OF PACKING MATERIAL. (a) Except as provided in par. (b), all packing material shall be stored in the fire-rated enclosure.

(b) 1. Packing material needed for immediate use may be kept outside the fire-rated enclosure.

2. All remaining packing material shall be returned to the fire-rated enclosure at the end of each day's work.

ILHR 14.112 CHEMICALLY SOILED WASTES. (1) CHEMICALLY SOILED CLOTH TOWELS AND RAGS. All chemically soiled linen towels and rags within all laboratories, beauty shops, beautician schools, barber shops and similar occupancies shall be kept in approved, listed self-closing metal waste cans, set firmly on 3-inch legs until removed from the building.

(2) CHEMICALLY SOILED PAPER PRODUCTS. All chemically soiled paper products within all laboratories, beauty shops, beautician schools, barber shops and similar occupancies shall be kept in approved, listed self-closing metal waste cans, set firmly on 3-inch legs. The contents of the can shall be removed from the building at the close of each day's work.

ILHR 14.113 CLEANLINESS. Every public building and place of employment, including connecting yards, courts, passages, areas or alleys, shall be kept clean and orderly, and shall be kept free from any accumulation of dirt, filth, rubbish, garbage or other matter.

ILHR 14.114 PROHIBITION OF SMOKING. (1) GENERAL. Smoking or carrying of lighted smoking materials shall be prohibited in public buildings and places of employment where flammable materials are handled, sold or stored.

Note: See Appendix for reprint of ch. ILHR 4 - Signs for Smoking Areas and s. 101.123, Stats.

(2) DESIGNATED SAFE LOCATIONS. The fire chief may designate specific safe locations in any building, structure or place in which smoking may be permitted.

(3) "NO SMOKING" SIGNS. The fire chief shall order the owner to post "No Smoking" signs in each building, structure, room or place in which smoking is prohibited. The content, lettering, size, color and location of required "No Smoking" signs shall be subject to the approval of the fire chief.

(4) REMOVAL OF SIGNS PROHIBITED. No person may obscure, remove, deface, mutilate or destroy a posted "No Smoking" sign.

(5) COMPLIANCE WITH "NO SMOKING" SIGNS. No person may smoke, throw or deposit any lighted or smoldering substance in any place where "No Smoking" signs are posted.

(6) ASH TRAYS. Noncombustible ash trays shall be provided at locations where smoking is permitted. The ash trays shall be of a design and construction to prevent smoking materials from falling out of the ash tray and shall be of a type which provides self-extinguishment of unattended smoking materials.

ILHR 14.115 OPEN FLAME OR LIGHT. (1) GENERAL. (a) Except as provided in par. (b), no person may take an open flame or light into any room or area, or other place where highly flammable, combustible or explosive material is kept.

(b) The use of open flame equipment for work requiring heat may be permitted subject to the approval of the fire chief having jurisdiction.

(2) OPEN FLAME CANDLES AND FIXTURES. (a) Except as provided in par. (b), the use of open flame candles or open flame fixtures in public buildings and places of employment shall be prohibited.

(b) 1. Open flame candles or open flame fixtures may be used in churches, fraternal lodges and other buildings as part of a religious, fraternal, or ceremonial ritual.

2. Candles may be used in restaurants, supper clubs and similar occupancies provided the candle is enclosed on all sides with glass or similar noncombustible material and the enclosure extends at least 1 inch above the tip of the flame.

3. Open flame candles and open flame fixtures may be used in the seating areas of public assembly buildings provided the following conditions are satisfied:

a. The stand upon which the candle is placed shall be non-tipping weighted stands or shall be securely attached to the end of the pew in at least 2 places;

b. The base of the candle shall be at least 78 inches from the floor;

c. The candle shall be guarded on top and sides at all times; and

Note: Compliance with this subparagraph may be attained by the use of a glass chimney and a perforated metal cap.

d. The aisle where the candles are placed shall be at least 5-foot wide.

4. Open flame food warming candles may be used in restaurants and similar occupancies.

5. The use of decorative or other lights, which are fueled by flammable or combustible liquids, may be used provided they are self-extinguishing.

ILHR 14.116 MATCHES. The manufacture, storage and distribution of matches shall comply with s. 167.07, Stats.

Note: See Appendix for reprint of s. 167.07, Stats.

ILHR 14.117 DILAPIDATED OR VACANT BUILDINGS. (1) DILAPIDATED BUILDINGS. (a) Any building which for any reason is especially liable to fire and which is so located as to endanger other buildings or property shall be repaired and put in safe and sound condition or shall be torn down and all materials removed.

(b) Conditions considered especially liable to fire shall include, but are not limited to, the following:

1. Missing or rotten shingles or similar defects on the roof;
2. Loose, missing or rotten siding;
3. Needless wall openings;
4. Broken plastering;
5. Holes in floors, ceilings or partitions;
6. Cracked or defective chimneys; and
7. Other conditions determined hazardous by the fire chief.

(c) The kind, form, manner or extent of repairs may be authorized by local ordinance when a building is damaged from any cause to an extent of more than 50% of its sound value.

(d) Within 30 days of written notification, the owner of a dilapidated building as specified in par. (a) shall decide whether to repair or tear down the building. Within 30 days of the decision, the building shall be repaired or torn down and all materials removed.

Note: Section 66.05, Stats., addresses the topic of razing buildings. A reprint of s. 66.05, Stats., is included in the Appendix of this chapter.

(2) VACANT BUILDINGS. (a) Upon vacating or abandoning any premises, the owner shall remove any and all noxious and hazardous material or waste matter and such premises shall be left in a clean and neat condition.

(b) Every person owning or in charge of or control of any vacant building shall remove all accumulations of flammable or combustible waste or rubbish and shall securely lock, barricade or otherwise secure all doors, windows and other openings.

ILHR 14.118 EXTENSION CORDS. (1) DEFINITION. In this section, "extension cord" means a cord set consisting of a length of flexible cord with an attachment plug at one end and a cord connector, which permits the connection of more than one attachment plug, at the other end.

Note: A cord set consisting of a length of flexible cord with an attachment plug at one end and a cord connector which permits a single attachment plug only at the other end is not an extension cord and its use is not regulated or prohibited by this rule.

(2) GENERAL. (a) Extension cords shall be listed by Underwriters' Laboratories or other approved nationally recognized testing agency.

Note: See Underwriters' Laboratories standard UL 817- Cord Sets and Power Supply Cords for additional information.

(b) 1. Extension cords shall have the load capacity for the intended load usage.

2. Extension cords shall be of a 3-wire grounding type when used in conjunction with devices equipped with 3-prong grounding type attachment plugs.

(c) 1. Except as provided in subd. 2., extension cords may not be multiplied or plugged into one another.

2. Extension cords may be multiplied or plugged together at construction sites provided ground-fault-circuit-interrupter protection is provided.

(d) Extension cords shall be of a length to eliminate the need to bundle or coil excess cord.

(3) APPLICATION. The use of extension cords shall be permitted in the following applications:

(a) At meetings or other activities which require the use of any type of projection equipment, recording equipment or other types of electrical equipment, if the extension cord shall be disconnected and removed at the conclusion of the meeting or activity;

(b) During periods of construction, remodeling, maintenance, repair or demolition of buildings, equipment or similar activity;

(c) For up to 90 days for Christmas decorative lighting, except that extension cords may not be used for decorative Christmas lighting on live trees in public buildings and places of employment;

(d) For temporary displays used for advertising purposes in public buildings and places of employment up to a maximum period of 30 days; and

(e) As power strips for surge or other protection needed for the proper control and operation of computers and data processing equipment, and meeting the following requirements:

1. The power strip shall be labeled and identified as providing surge protection.

2. The power strip shall be permanently mounted to the equipment or furniture used in conjunction with the equipment, with any excess cord located to prevent any physical damage to the cord.

Note: See ss. ILHR 16.31 and NEC 400-8 for additional information.

Subchapter V - Building Components and Construction

ILHR 14.119 CHIMNEYS AND HEATING APPLIANCES. (1) INSTALLATION AND MAINTENANCE. (a) All chimneys, incinerators, smokestacks or similar devices for conveying smoke or hot gases to the outside and the stoves, furnaces, fire-boxes or boilers to which they are connected shall be constructed in accordance with ss. ILHR 64.45 to 64.50 and shall be maintained so as not to create a fire hazard.

Note: See Appendix for reprint of ss. ILHR 64.45 to 64.50.

(b) Chimneys or vents and connectors serving solid-fuel burning appliances shall be cleaned and inspected for damage annually.

(c) Chimneys and vents, which have been subjected to a chimney fire, shall not be reused until inspected and approved by the department or authorized deputy.

(2) EXISTING INSTALLATIONS. (a) 1. Existing masonry chimneys which upon inspection are found to be without flue liners and with open mortar joints which will permit smoke or gases to be discharged into the building, or which are cracked as to be dangerous shall be made safe by means of a fire-clay liner, fire-brick, a corrosion-resistant metal pipe or other approved materials and otherwise repaired if necessary, the chimney shall be removed or the chimney openings shall be effectively sealed to prevent further use.

2. Metal pipe liners shall be one inch less in diameter than the least dimension of the flue, and the entire space between the metal liner and the walls of the chimney shall be filled with cement mortar.

(b) Existing chimneys and vents of metal, which are corroded or improperly supported, shall be repaired or replaced.

(c) Existing chimney and vent connectors of metal, which are corroded or improperly supported, shall be replaced.

(3) FOOD PREPARATION EQUIPMENT. (a) Exhaust systems provided for food preparation equipment shall be maintained in a manner such as not to create a hazardous condition.

Note: See s. ILHR 64.67 (6) for additional information. A reprint of s. ILHR 64.67 (6) is included in the Appendix.

(b) Hoods, grease removal devices, fans, ducts and other devices shall be inspected and cleaned semi-annually or more often as needed to remove grease and deposits of residues.

(c) 1. Fire extinguishing systems shall be inspected semi-annually and checked for proper operation by a factory-authorized service representative. Inspections shall include a check that the supply of extinguishing agent in the system is adequate, and all actuation components are operating satisfactorily.

2. Fusible links shall be replaced at least annually.

3. A copy of the semi-annual inspection report shall upon request be sent to the fire department having jurisdiction.

(d) Instructions for manually operating the fire extinguishing system shall be posted conspicuously in the kitchen, and employes shall be checked for their knowledge of operating procedures.

(e) Any fire dampers, if employed, shall be tested periodically to insure proper functioning of all parts.

(4) UNSAFE HEATING APPLIANCES. (a) Any existing stove, oven, furnace, incinerator, boiler or any other heat producing device or appliance found to be defective or in violation of code requirements may not be used. The fire chief shall order the discontinuation of use with a written notice to the owner, firm, agent or operator of the equipment to cease use immediately.

(b) The fire chief shall seal any device or appliance without notice when inspection shows the existence of an immediate fire hazard or that the device or appliance imperils life.

(c) The defective appliance shall remain withdrawn from service until all necessary repairs or alterations have been made.

ILHR 14.120 SERVICE EQUIPMENT AREAS. (1) ILLUMINATION. Illumination shall be provided for all service equipment areas, motor control centers and electrical panelboards.

(2) CLEARANCE. (a) Clearance of not less than 36 inches shall be provided between all electrical service equipment and storage.

(b) Clearances to heat producing equipment shall be provided as specified in the listing for the equipment.

(3) STORAGE PERMITTED. Storage shall be permitted in the isolation of hazard rooms specified in chs. ILHR 54 to 62 provided the clearances to heat producing equipment as specified in sub. (2) (b) and in NFPA Standard 211 as adopted in s. ILHR 51.27 (7) (b) are maintained.

ILHR 14.121 INTERIOR FINISHES AND FLAMMABLE AND DECORATIVE MATERIALS. (1) INTERIOR FINISH MATERIALS. Interior finish materials installed in public buildings and places of employment since January 1, 1982, shall comply with the provisions of s. ILHR 51.07.

Note #1: Section ILHR 51.07 became effective on January 1, 1982 and applies only to finish materials installed subsequent to the effective date.

Note #2: See Appendix for reprint of s. ILHR 51.07.

(2) THEATRES AND ASSEMBLY HALLS. (a) Fabric decorations used in theatres and assembly halls shall be flameproofed.

(b) For fabrics treated on or after the effective date of the section, a tag or similar indication shall be affixed to the fabric and include the following information:

1. Date of flameproofing treatment;
2. Period of time for which the treatment is effective or expiration date when flameproofing is no longer effective; and
3. Name of person or firm responsible for the flameproofing treatment.

(c) The use of paper decorations, confetti or flammable decorative material shall be prohibited.

(3) Live and Artificial Christmas Trees. Live and artificial Christmas tree, except those within individual living units, shall be flameproofed as specified in sub. (2).

ILHR 14.122 FIRE-RESISTIVE CONSTRUCTION AND COMPONENTS. (1) GENERAL. Fire division walls, fire separation walls, occupancy separations and all other fire-resistive rated construction and components required by the provisions of chs. ILHR 50 to 64 shall be maintained.

(2) OPENINGS. (a) 1. Except as provided in subd. 2., all openings for doors and windows in required fire-rated construction shall be protected by fire door or fire window assemblies as specified in ss. ILHR 51.047 and 51.048, respectively.

2. Openings in the fire resistive rated walls and partitions rated only to meet class of construction requirements as specified in s. ILHR 51.03 need not be protected by fire door or fire window assemblies.

Note: See Appendix for reprint of ss. ILHR 51.047 and 51.048.

(b) All hardware needed for proper operation of fire door and fire window assemblies shall be maintained in good working order.

(c) The use of door stops, wedges and other nonapproved hold-open devices shall be prohibited on fire doors.

(d) No fire door may be blocked or obstructed or otherwise made inoperable.

(e) Approved hold-open devices and automatic door closers, if used, shall be maintained in good working order. During any period when the hold-open device or automatic door closer is out of service for repairs, the door it operates shall remain in the closed position.

(f) 1. Except as provided in subd. 2., all doors serving smokeproof stair towers or interior enclosed stairways shall be equipped with a self-closing device or an automatic self-closing device actuated by products of combustion other than heat.

2. The self-closing device may be actuated by a rate-of-rise heat detectors in those locations with smoke-or contaminated-filled environments.

(g) The doors protecting openings in vertical division walls of ch. ILHR 57 buildings and located in public corridors shall be held open and equipped with an automatic closing device activated by products of combustion other than heat.

Subchapter VI - Fire Prevention, Detection and Protection Systems

ILHR 14.123 GENERAL REQUIREMENTS. All fire prevention, detection and protection systems, including automatic fire sprinkler systems, automatic fire suppression systems, standpipe systems, manual fire alarm systems, smoke detection systems, smoke detectors, heat detection systems, heat detectors, portable fire extinguishers and related systems shall be designed, installed and maintained as specified in this subchapter and chs. ILHR 50 to 64.

Note: See Appendix for reprint of ss. ILHR 51.21 to 51.245 of the Wisconsin Building and Heating, Ventilating and Air Conditioning Code.

ILHR 14.124 AUTOMATIC FIRE SPRINKLER SYSTEMS. Automatic fire sprinkler systems shall be tested, inspected and maintained as specified in NFPA No. 13A - Inspection, Testing, and Maintenance of Sprinkler Systems, as adopted by reference in s. ILHR 51.27 (7).

Note: See Appendix for reprint of NFPA No. 13A.

ILHR 14.125 STANDPIPE SYSTEMS. Standpipe systems shall be tested, inspected, and maintained as specified in NFPA No. 14 - Standpipe and Hose Systems, Ch. 8 - Tests and Inspections, as adopted by reference in s. ILHR 14.029.

Note: See Appendix for reprint of NFPA No. 14, ch. 8.

ILHR 14.126 MANUAL FIRE ALARM SYSTEMS. Manual fire alarm systems shall be tested, inspected and maintained as specified in NFPA No. 72A - Installation, Maintenance and Use of Local Protective Signaling Systems, as adopted by reference in s. ILHR 51.27 (7).

Note: See Appendix for reprint of NFPA No. 72A.

ILHR 14.127 SMOKE DETECTION SYSTEMS, HEAT DETECTION SYSTEMS, SMOKE DETECTORS AND HEAT DETECTORS. Smoke detection systems, heat detection systems, smoke detectors and heat detectors shall be tested, inspected and maintained as specified in NFPA No. 72E - Automatic Fire Detectors and NFPA No. 74 - Household Fire Warning Equipment, as adopted by reference in s. ILHR 51.27 (7).

Note: See Appendix for partial reprint of NFPA Nos. 72E and 74.

ILHR 14.128 PORTABLE FIRE EXTINGUISHERS. Portable fire extinguishers shall be tested, inspected and maintained as specified in NFPA No. 10 - Portable Fire Extinguishers, as adopted by reference in s. ILHR 51.27 (7).

Note: See Appendix for partial reprint of NFPA No. 10.

ILHR 14.129 OTHER FIRE SAFETY DEVICES. Special fire safety devices, including automatic smoke removal and control equipment, emergency generators and any other special fire safety equipment shall be tested annually by the owner or an authorized representative, and the results of such tests shall be logged in a journal kept available for inspection by the fire chief.

ILHR 14.130 TEST RECORDS. A complete written record of all tests and inspections required under this subchapter shall be maintained on the premises by the owner or occupant in charge of the premises, and all such records shall be submitted to the fire chief when requested for inspection and evaluation.

ILHR 14.131 UNSAFE BUILDINGS. (1) GENERAL. Except as provided in sub. (2), when any required fire alarm, fire communication, fire extinguishing, fire detecting, first-aid fire fighting system, device or unit, or part becomes inoperative and affects the fire safety of a building or structure or the occupants, the fire chief shall order the building or structure or portion vacated until the inoperative system, device or unit is repaired and returned to full service.

(2) EXCEPTION. Buildings may be occupied during servicing of the systems specified in sub. (1) provided safety alternatives approved by the fire chief are utilized until the system is placed back in operation.

ILHR 14.132 BUILDINGS UNDER CONSTRUCTION. (1) GENERAL. During the construction of a building and until the permanent fire-extinguishing system has been installed and is in service, fire protection shall be provided in accordance with this section.

(2) WHERE REQUIRED. (a) Every building 6 stories or more in height shall be provided with not less than one Class I standpipe for use during construction.

(b) The standpipes shall be installed when the progress of construction is not more than 50 feet in height above grade.

(c) The standpipe shall be provided with fire department inlet connections at accessible locations adjacent to usable stairs.

(d) The standpipe systems shall be extended as construction progresses to within one floor of the highest point of construction having secured decking or flooring.

(e) On each floor there shall be provided a 2-1/2 inch valve outlet for fire department use. Where construction height requires installation of a Class II standpipe, fire pumps and water main connections shall be provided to serve the standpipe.

(3) TEMPORARY STANDPIPES. (a) Temporary standpipes may be provided in place of permanent systems if they are designed to furnish 500 gallons of water per minute at 50 pounds per square inch pressure with a standpipe size of not less than 4 inches.

(b) All outlets shall be not less than 2-1/2 inches.

(c) Pumping equipment sufficient to provide the pressure and volume specified in par (a) shall be available at all times when a Class III standpipe system is required.

(4) DETAILED REQUIREMENTS. Standpipe systems for buildings under construction shall be installed as required for permanent standpipe systems.

ILHR 14.133 VACANT BUILDINGS. (1) GENERAL. Except as provided in sub. (2), the owner of vacant or unoccupied buildings or portions shall maintain all required sprinkler and standpipe systems and all component parts in a workable condition at all times. Fire alarm systems shall be maintained in operating condition at all times.

(2) EXCEPTION. (a) If the building is vacated for periods of time of more than one week, the fire alarm systems may be rendered inoperable. Before the building is occupied, the fire alarm system shall be restored and tested in the presence of the fire chief.

(b) In vacant or unoccupied buildings, where the fire chief determines the type of construction, fire separation and security of the building is not a fire hazard, the fire chief may permit the fire protection systems to be taken out of service in a manner and for a time as the chief specifically prescribes.

ILHR 14.134 BUILDINGS UNDER DEMOLITION. When a building is being demolished and a standpipe or sprinkler system is existing within the building, the standpipe or sprinkler system or both shall be maintained in an operable condition so as to be available for use by the fire department. The standpipe or sprinkler system or both shall be demolished with the building, but in no case shall the system, or systems, be more than one floor below the floor being demolished.

Subchapter VII - Means of Egress

ILHR 14.135 GENERAL REQUIREMENTS. All means of egress in public buildings and places of employment shall be provided and maintained as specified in chs. ILHR 50 to 64.

Note: See Appendix for reprint of ss. ILHR 51.15 to 51.20 and related sections from the occupancy chapters.

Subchapter VIII - Flammable and Combustible Liquids

Note: See NFPA No. 30 and related standards as adopted by reference in ch. Ind 8 - Flammable and Combustible Liquids Code and the text of ch. Ind 8.

Subchapter IX - Oil Burning Equipment

Note: See NFPA No. 31 as adopted by reference in ch. Ind 8 - Flammable and Combustible Liquids Code.

Subchapter X - Organic Coatings

Note: See NFPA No. 35 as adopted by reference in ch. Ind 8 - Flammable and Combustible Liquids Code.

Subchapter XI - Hazardous Materials and Chemicals

Note: See NFPA No. 45 as adopted by reference in ch. Ind 8 - Flammable and Combustible Liquids Code.

Subchapter XII - Application of Flammable Finishes

Note: See NFPA Nos. 33 and 34 as adopted by reference in ch. Ind 8 - Flammable and Combustible Liquids.

Note: See s. 1910.147 for the federal Occupational Safety and Health Administration standards for requirements dealing with spray booths.

Subchapter XIII - Service Stations and Garages

Note: See NFPA No. 30A as adopted by reference in ch. Ind 8 - Flammable and Combustible Liquids Code and the text of ch. Ind 8.

Subchapter XIV - Liquefied Petroleum Gases

Note: See NFPA Nos. 54, 58, 59 and 501C as adopted by reference in ch. ILHR 11 - Liquefied Petroleum Gases and the text of ch. ILHR 11.

Subchapter XV - Liquefied Natural Gas

Note: See NFPA No. 59A as adopted by reference in ch. ILHR 12 - Liquefied Natural Gas and the text of ch. ILHR 12.

Subchapter XVI - Compressed Natural Gas

Note: See NFPA No. 52 as adopted by reference in ch. ILHR 13 - Compressed Natural Gas and the text of ch. ILHR 13.

Subchapter XVII - Public Buildings and Places of Employment

ILHR 14.136 GENERAL REQUIREMENTS. All public buildings and places of employment shall be designed, constructed, operated and maintained as specified in chs. ILHR 50 to 64 and as specified in this chapter.

Subchapter XVIII - Bowling Establishments

ILHR 14.137 PERMIT REQUIRED. A permit shall be obtained from the fire chief for bowling pin refinishing and bowling lane resurfacing operations involving the use and application of flammable liquids or materials.

ILHR 14.138 PRIOR NOTIFICATION. The fire chief shall be notified when bowling lanes are to be resurfaced.

ILHR 14.139 PROHIBITIONS DURING LANE RESURFACING OPERATIONS. (1) BUSINESS HOURS. Resurfacing operations may not be carried on while the establishment is open for business.

(2) RECIRCULATION OF AIR. Heating, ventilating or cooling systems employing recirculation of air may not be operated during resurfacing operations or within one hour following the application of flammable finishes.

(3) SOURCES OF IGNITION. All electric motors or other equipment in the area which might be a source of ignition shall be shut down, and all smoking and use of open flames shall be prohibited during the application of flammable finishes and for one hour thereafter.

ILHR 14.140 VENTILATION. Mechanical ventilation shall be provided to remove flammable vapors.

ILHR 14.141 WASTE MATERIALS. A metal waste can with a self-closing cover shall be provided for all waste materials and rags, and the contents shall be disposed of daily.

ILHR 14.142 PIN REFINISHING. (1) ISOLATION OF HAZARD. Pin refinishing involving the application of flammable finishes shall be done only in a room isolated from the remainder of the building by at least 2-hour fire-resistive rated construction.

(2) SMOKING PROHIBITED. Smoking shall be prohibited at all times in the pin refinishing room.

(3) POWER TOOLS. All power tools used in the pin refinishing room shall be grounded.

(4) DUST COLLECTION. A metal box or other receptacle shall be provided for catching dust thrown off during operation of lathes and sanding or buffing machines. The contents shall be removed daily and disposed of safely.

(5) STORAGE OF FLAMMABLE OR COMBUSTIBLE LIQUIDS. Storage of flammable or combustible liquids in pin refinishing rooms may not exceed a combined aggregate of 60 gallons in original metal containers, or 5 gallons individual capacity in approved safety containers.

Subchapter XIX - Tents and Air Supported Structures

ILHR 14.143 GENERAL REQUIREMENTS. (1) TENTS. Tents shall comply with the provisions of this subchapter and of ch. ILHR 62, subch. III.

Note: See Appendix for reprint of ch. ILHR 62, subch. III.

(2) AIR-SUPPORTED STRUCTURES. Air-supported structures shall comply with the provisions of this subchapter.

ILHR 14.144 PARKING OF VEHICLES. Automotive equipment that is necessary to the operation of the establishment may not be parked within 20 feet of the tent or air-supported structure except by special permission of the fire chief. No other automotive equipment or internal combustion engines may be parked within 50 feet of the tent except upon a public street.

ILHR 14.145 LOCATION OF AIR-SUPPORTED STRUCTURES AND TENTS. (1) An air-supported structure shall be located not less than 10 feet from any property line or permanent structure except where the property line is a street or alley.

(2) Air-supported structures having a floor area in excess of 1500 square feet but less than 15,000 square feet shall be located not less than 30 feet from any other air-supported structure, tent or structure.

(3) Air-supported structures having an area of 15,000 square feet or more shall be located not less than 50 feet from any other structure or tent as measured from the side wall of the structure, unless joined together by a corridor.

(4) Unless otherwise approved by the fire chief, an unobstructed passageway or fire road not less than 12 feet in width and free from guy ropes or other obstructions shall be maintained on all sides of all tents or air-supported structures.

ILHR 14.146 FLAME RETARDANT TREATMENT (1) GENERAL. (a) The side wall, drops and top of all tents and air-supported structures shall be of flame-retardant material or shall be made fire retardant in a manner approved by the department.

(b) All bunting and other flammable decorations or effects, sawdust or wood chips when used on floors or passageways, shall be treated with a flame-retardant solution.

(2) AFFIDAVIT. An affidavit or affirmation shall be retained at the premises on which the tent or air-supported structure is located, attesting to the following information relative to the flame-retardant treatment of the fabrics:

- (a) The date the fabric was last treated with flame-retardant solution;
- (b) The trade name of kind of chemical used in treatment;
- (c) The name of person or firm treating the material; and
- (d) The name and address of the owner of the tent.

ILHR 14.147 SMOKING AND OPEN FLAME. (1) SMOKING. Smoking shall be prohibited in any tent or air-supported structure or in any adjacent areas where hay, straw, alfalfa, sawdust or other highly combustible materials are kept or stored. Approved "No Smoking" signs shall be conspicuously posted.

(2) OPEN FLAME. No fireworks, open flame or other device emitting flame or fire may be used in or immediately adjacent to any tent or air-supported structure while open to the public, except upon special permission from the fire chief.

ILHR 14.148 FIRE EXTINGUISHERS AND OTHER FIRE PROTECTION EQUIPMENT.

(1) FIRE EXTINGUISHERS. Fire extinguishers and other fire protection equipment shall be provided in every tent or air-supported structure as follows:

(a) One 2-A type extinguisher shall be provided in every tent or air-supported structure having a floor area of more than 500 square feet but less than 1000 square feet and also one in each adjacent auxiliary tent or air-supported structure. One additional 2-A type extinguisher shall be provided for each additional 2000 square feet or fraction thereof.

(b) At least one 10-B:C type fire extinguisher shall be provided for each eating area, power generator or transformer and at locations where flammable or combustible liquids are used, stored or dispensed.

(c) At least one 40-B:C type fire extinguisher shall be provided for each kitchen.

(2) OTHER EQUIPMENT. Fire hose lines, water supplies and other auxiliary fire equipment shall be maintained at the site in such numbers and sizes as may be required by the fire chief.

ILHR 14.149 ABATEMENT OF SPECIAL FIRE OR PANIC HAZARDS. Any unforeseen condition that presents a fire hazard or would contribute to the rapid spread of fire, or would delay or interfere with the rapid exit of persons from the tent or air-supported structure, or would interfere with or delay the extinguishment of a fire and which is not otherwise covered by this subchapter shall be immediately abated, eliminated or corrected as ordered by the fire chief.

ILHR 14.150 FLAMMABLE AND COMBUSTIBLE LIQUIDS (1) GENERAL. Flammable or combustible liquids may not be stored in a tent or air-supported structure nor less than 50 feet from any tent or air-supported structure used for public assemblage.

(2) STORAGE AND DISPENSING. The storage and dispensing of flammable or combustible liquids shall be in accordance with ch. Ind 8.

(3) LIQUEFIED PETROLEUM GASES. Liquefied petroleum gas may not be stored or used in connection with any tent or air-supported structure unless the storage containers, equipment, fittings and appliances, and the placement, use and operation of such equipment comply with ch. ILHR 11.

ILHR 14.151 HOUSEKEEPING. (1) WEEDS AND VEGETATION. All weeds and flammable vegetation shall be removed from the premises adjacent to or within 35 feet of any tent or air-supported structure.

(2) COMBUSTIBLE MATERIAL. Hay, straw, trash and other flammable material may not be stored less than 35 feet from any tent or air-supported structure, except upon special permission from the fire chief.

(3) COMBUSTIBLE WASTE. The grounds both inside and outside of tents and air-supported structures shall be kept free and clear of combustible waste. The waste shall be stored in approved containers or removed from the premises. The burning of waste on the premises shall be prohibited except upon specific permission from the fire chief.

Subchapter XX - Dry Cleaning Plants

Note: See ch. ILHR 15 - Cleaning and Dyeing.

Subchapter XXI - Lumber Yards

ILHR 14.152 PERMIT REQUIRED. A permit shall be obtained from the fire chief for any facility or operation in which more than 100,000 board feet of lumber is to be stored or used.

ILHR 14.153 OPEN YARD STORAGE AND DRIVEWAYS. Open yard storage and driveways in lumberyards shall comply with s. ILHR 14.110 (3).

ILHR 14.154 FENCES. Permanent outdoor lumber storage in excess of 100,000 board feet shall be surrounded by a fence at least 6 feet high.

ILHR 14.155 OPERATIONAL FIRE HAZARDS. (1) BURNING OF REFUSE MATERIALS. Where approved by the department of natural resources and the fire chief, the burning of shavings, sawdust and refuse materials shall be only in boilers, furnaces, incinerators or refuse burners, safely constructed and located.

(2) SPARK PROTECTION. Stacks shall be provided with approved spark arresters having openings not greater than 3/4 inch, or other effective means provided, such as an expansion chamber, baffle walls or other effective arrangement, which will eliminate the danger from sparks.

(3) STORAGE FACILITY. At the boiler or other points where sawdust or shavings are used as fuel, a storage bin of noncombustible construction with raised sill shall be provided.

ILHR 14.156 SMOKING PROHIBITED. Smoking shall be prohibited except in specified safe locations in buildings. "No Smoking" signs shall be posted on exterior building walls and at the edges of driveways. "No Smoking" signs shall be posted throughout all buildings except in specific locations designated as safe for smoking purposes.

ILHR 14.157 YARDS. Weeds shall be kept down throughout the entire yard and shall be sprayed, cut or dug out. Dead weeds shall be removed.

ILHR 14.158 REMOVAL OF DEBRIS. Debris, such as sawdust, chips and scrap pieces shall be removed regularly from piling areas and not less frequently than quarterly. Proper housekeeping shall be maintained at all times.

ILHR 14.159 FIRE EXTINGUISHING EQUIPMENT. (1) YARD HYDRANT (a). An approved yard hydrant system shall be provided for open storage yards.

(b) The provisions of par. (a) shall apply to lumber storage yards constructed on or after the effective date of this section.

(2) FIRE EXTINGUISHERS (a). Portable fire extinguishing equipment as specified in NFPA No. 10 for the fire hazard involved shall be provided.

(b) When used, approved Class A portable fire extinguishers, properly protected against freezing where necessary, shall be provided so that the travel distance from any point in the yard to the nearest extinguisher does not exceed 75 feet.

Note: See Appendix for partial reprint of NFPA Standard 10.

Subchapter XXII - Woodworking Plants

ILHR 14.160 REFUSE REMOVAL. (1) REMOVAL SYSTEM OR BINS. Sawmills, planing mills and other woodworking plants shall be equipped with either:

(a) Refuse removal systems which will collect and remove sawdust and shavings as produced; or

(b) Suitable metal or metal-lined bins, provided with normally closed covers or automatically closing covers, shall be installed at or near such machines. Shavings and sawdust shall be swept up and deposited in such bins at sufficiently frequent intervals as to keep the premises clean.

(2) BLOWERS AND EXHAUST SYSTEMS. Blower and exhaust systems shall be installed in accordance with nationally recognized good practice.

ILHR 14.161 FIRE PROTECTION. Fire fighting equipment, either portable fire extinguishers as specified in NFPA No. 10 or minimum 1/2-inch diameter hose supplied from a water system, shall be provided near any machine producing shavings or sawdust.

Note: See Appendix for partial reprint of NFPA Standard 10.

Subchapter XXIII - Vehicle Tire Rebuilding Plants

ILHR 14.162 PERMIT REQUIRED. A permit shall be obtained from the fire chief to conduct or maintain any tire recapping or rebuilding operation.

ILHR 14.163 REFUSE REMOVAL. (1) REMOVAL SYSTEM OR BINS. Vehicle tire rebuilding plants shall be equipped with either:

(a) Refuse removal systems which will collect and remove dust and shavings as produced; or

(b) Suitable metal or metal-lined bins, provided with normally closed covers or automatically closing covers, which shall be installed at or near such machines. Shavings and dust shall be swept up and deposited in such bins at sufficiently frequent intervals as to keep the premises clean.

(2) BLOWERS AND EXHAUST SYSTEMS. Blower and exhaust systems shall be installed in accordance with nationally recognized good practice.

ILHR 14.164 VENTILATION. Each room where rubber cement is used or mixed, or flammable or combustible solvents are applied, shall be equipped with mechanical or natural ventilation.

Subchapter XXIV - Fireworks

Note: See ch. ILHR 9 - Manufacture of Fireworks.

Subchapter XXV - Explosives, Ammunition and Blasting

Note: See ch. ILHR 7 - Explosive Materials.

Subchapter XXVI - Magnesium

ILHR 14.165 PERMIT REQUIRED. A permit shall be obtained from the fire chief for the melting, casting, heat treating, machining or grinding of more than 10 pounds of magnesium per working day.

ILHR 14.166 STORAGE OF MAGNESIUM. (1) OUTSIDE STORAGE. Outside storage of magnesium pigs, ingots and billets shall be in piles not exceeding 500 tons each, separated by aisles not less in width than one-half the height of the pile, and separated from combustible materials or buildings on the same or adjoining property by a distance of not less than the height of the nearest pile.

(2) INSIDE STORAGE. Storage of pigs, ingots and billets in buildings shall be on floors of noncombustible construction, in piles not larger than 250 tons each, separated by aisles not less in width than one-half the height of the pile.

(3) ARTICLES. The size of storage piles of magnesium articles in foundries and processing plants shall not exceed 1,250 cubic feet and shall be separated by aisles not less in width than one-half the height of the pile.

(4) ARTICLES WAREHOUSES AND STORES. Magnesium storage in a quantity greater than 50 cubic feet shall be separated from storage of other materials that are either combustible or are in combustible containers, by aisles equal in width to not less than the height of the piles of magnesium.

(5) MAXIMUM PILE SIZES. Magnesium storage in a quantity greater than 1,000 cubic feet shall be separated into piles each not larger than 1,000 cubic feet with aisles between each pile equal in width to not less than the height of the piles.

(6) COMBUSTIBLE BUILDINGS OR CONTAINERS. Where storage in a quantity greater than 1,000 cubic feet is in a building of combustible construction, or the magnesium is packed in combustible crates or cartons, or there is other combustible storage within 30 feet of the magnesium, the storage area shall be protected by an automatic fire sprinkler system.

ILHR 14.167 HANDLING OF MAGNESIUM. (1) PROCESSING OPERATIONS. At each grinding, buffing or wire-brushing operation on magnesium, not including rough finishing of castings, dust shall be collected by means of hoods or enclosures connected to a liquid precipitation type of separator, so that the dust will be converted to sludge without contact in a dry state with any high speed moving parts.

(2) CONNECTING DUCTS. Connecting ducts or suction tubes shall be completely grounded and as short as possible, without unnecessary bends. Ducts shall be carefully fabricated and assembled, with a smooth interior and with internal lap joints pointing in the direction of air flow, and without unused capped side outlets, pockets or other dead-end spaces which might allow an accumulation of dust.

(3) DUST SEPARATORS. Each machine shall be equipped with an individual dust separating unit, except that with multi-unit machines not more than 2 dust-producing units may be served by one separator. Not more than 4 portable dust-producing units in a single enclosure or stand may be served by one separator unit.

(4) POWER INTERLOCKS. Power supply to dust-producing machines shall be interlocked with the motor driving the exhaust blower and the liquid level controller of the wet collector in such a way that improper functioning of the dust collecting system will shut down the machine it serves. A time delay switch or equivalent device shall be provided in the dust-producing machine to prevent starting of its motor drive until the wet collector is in complete operation and several changes of air have swept out any residual hydrogen.

(5) ELECTRICAL SYSTEM. All electrical wiring, fixtures and equipment in the immediate vicinity of and attached to dust-producing machines, including those used in connection with separator equipment, shall be of types approved for use in Class II, Group E, hazardous locations as specified in ch. ILHR 16.

(6) GROUNDING. All equipment shall be securely grounded by permanent ground wires.

(7) HEAT TREATING OVENS. Approved means shall be provided for control of magnesium fires in heat treating ovens.

(8) MELTING POTS. Floors under and around melting pots shall be of noncombustible construction.

(9) HANDLING OF FINES. Chips, turnings and other fine magnesium scrap shall be collected from the pans or spaces under the machines and from other places where they collect at least once each working day and placed in a covered, vented steel container and removed to a safe location.

(10) SEPARATION. (a) Magnesium fines shall be kept separate from other combustible materials.

(b) Storage in a quantity greater than 50 cubic feet of fine magnesium scrap shall be separated from other uses by at least 2-hour rated fire-resistive construction without window openings or by an open space of at least 50 feet.

(c) Storage in a quantity greater than 1,000 cubic feet of fine magnesium scrap shall be separated from all buildings other than those used for magnesium scrap recovery operations by a distance of not less than 100 feet.

ILHR 14.168 FIRE SAFETY REQUIREMENTS. (1) SMOKING PROHIBITED. (a) Smoking shall be prohibited in areas where magnesium is being stored, melted, casted, heat treated or grounded.

(b) "No Smoking" signs shall be posted in all areas specified in sub. (1).

(2) FIRE EXTINGUISHING POWDER. A supply of approved extinguishing powder in a container with a hand scoop or shovel for applying powder on magnesium fires or an approved extinguisher unit designed for use with the powder shall be kept within easy reach of every operator performing a machining, grinding or other processing operation on magnesium.

Subchapter XXVII - Cryogenic Liquids

ILHR 14.169 DEFINITIONS. In this subchapter:

(1) "Container" means any cryogenic vessel whether used for transportation or storage.

(2) "Cryogenic vessel" means any pressure vessel, low pressure tank, or atmospheric tank on which venting, insulation, refrigeration, or a combination of these, are used in order to maintain the operating pressure, and the contents in a liquid phase.

(3) "Cryogenic liquid" means those liquids that have a boiling point below -200 degrees F.

(4) "Flammable cryogenic liquid" means those cryogenic liquids which are flammable in their vapor state.

ILHR 14.170 PERMIT REQUIRED. A permit shall be obtained from the fire chief for:

(1) The production, storage or sale of cryogenic liquids;

(2) The storage of nonflammable, nontoxic cryogenic liquids in quantities greater than 500 gallons; or

(3) The storage or use of more than 10 gallons of liquid oxygen, flammable cryogenic liquids or cryogenic oxidizers.

ILHR 14.171 CONTAINERS AND EQUIPMENT. (1) PROTECTION. All containers, valves and piping shall be located so that they are readily accessible for inspection and repair and shall be protected against tampering.

(2) CONTAINER DESIGN AND CONSTRUCTION. (a) All containers, including piping, valves and pressure relief devices, shall be located, designed and constructed in accordance with the requirements of nationally recognized standards for the intended use.

(b) Containers and related piping and components shall be maintained in a safe and sound condition.

(3) WARNING LABELS. Warning labels and signs regarding cryogenic contents shall be posted on all containers and equipment.

ILHR 14.172 FIRE SAFETY REQUIREMENTS. (1) GENERAL. Dispensing of flammable cryogenic liquids, liquefied oxygen or liquid oxidizers shall be only at locations approved by the fire chief. Water lines and hose shall be provided for cleaning the area and melting ice accumulations.

(2) SOURCES OF IGNITION. (a) Flammable cryogenic liquids, liquid oxygen or cryogenic oxidizers may not be loaded, unloaded, dispensed or handled where vapors can reach a source of ignition.

(b) Smoking shall be prohibited and "No Smoking" signs shall be conspicuously posted.

(c) Loading, unloading and dispensing of oxygen shall be prohibited in the vicinity of loading, unloading or dispensing of gaseous or liquid fuel.

ILHR 14.173 TRANSPORTATION. (1) CONTAINERS-TANKS-VESSELS. Containers, tanks and vessels used for transporting cryogenic liquids shall meet all applicable requirements of 49 CFR.

(2) VEHICLES. (a) Vehicles used for transportation of cryogenic liquids shall be placarded at the front, rear and each side with the name of the product in addition to placards which are required by 49 CFR.

(b) Vehicles shall be equipped with at least one approved fire extinguisher with a minimum 20-B:C rating and with wheel chock blocks.

Subchapter XXVIII - Welding, Cutting, and Brazing

ILHR 14.174 GENERAL. All welding and cutting; storage, handling and use of calcium carbide; and use of acetylene generators shall be as specified in Subpart Q - Welding, Cutting and Brazing, of OSHA Safety and Health Standards 29CFR1910.

Note: See Appendix for reprint of Subpart Q of 29CFR1910.

Subchapter XXIX - Cellulose Nitrate Motion Picture Film

ILHR 14.175 PERMIT REQUIRED. (1) A person may not store, keep or have on hand more than 25 pounds of cellulose nitrate film without securing a permit from the fire chief for the activity.

(2) A person may not sell, lease or otherwise dispose of any cellulose nitrate film to any person not having a permit issued by the fire chief to handle, use or display the film.

ILHR 14.176 PROJECTION BOOTHS. Projection booths used in conjunction with cellulose nitrate motion picture film shall comply with ss. ILHR 55.40 to 55.49.

Note: See Appendix for reprint of ss. ILHR 55.40 to 55.49.

Subchapter XXX - Cellulose Nitrate Plastics

ILHR 14.177 PERMIT REQUIRED. (1) STORAGE AND HANDLING. All retailers, jobbers and wholesalers storing or handling more than 25 pounds of cellulose nitrate plastics shall obtain a permit from the fire chief.

(2) MANUFACTURING. A permit shall also be obtained from the fire chief for the manufacture of articles of cellulose nitrate plastics, including the use of cellulose nitrate plastics in the manufacture or assembling of other articles.

ILHR 14.178 FIRE SAFETY REQUIREMENTS. (1) SMOKING PROHIBITED. Smoking is prohibited in all areas where cellulose nitrate plastics is stored, handled or manufactured. "No Smoking" signs shall be clearly posted in these areas.

(2) FIRE PROTECTION EQUIPMENT. All new and existing buildings or any portions of the building used for the manufacture or storage of articles of cellulose nitrate plastics shall be equipped with an approved automatic fire suppression system. Vaults located within buildings for the storage of raw pyroxylin shall be protected with an approved automatic fire sprinkler system capable of discharging 1.66 gallons per minute per square foot over the area of the vault.

Subchapter XXXI - Combustible Fibers

ILHR 14.179 SCOPE. The equipment, processes and operations for handling, storage or use of combustible vegetable or animal fibers, including but not limited to readily ignitable and free burning fibers such as cotton, sisal, henequen, ixtle, jute, hemp, tow, cocoa fiber, oakum, baled waste, baled waste paper, kapok, hay, straw, Spanish moss, excelsior, certain synthetic fibers and cloth in the form of scraps and clippings, shall comply with the provisions of this subchapter.

ILHR 14.180 PERMIT REQUIRED. A permit shall be obtained from the fire chief for the storage and handling of combustible fibers in quantities in excess of 100 cubic feet.

ILHR 14.181 STORAGE (1) LOOSE STORAGE. (a) Except as provided in pars. (b) to (e), loose combustible fibers not in bales or packages, whether housed or in the open, may not be stored within 100 feet of any building.

(b) Not more than 100 cubic feet of loose combustible fibers may be kept in any building, provided storage is in a metal or metal-lined bin equipped with a self-closing cover.

(c) Quantities exceeding 100 cubic feet of loose combustible fibers, but not exceeding 500 cubic feet, may be stored in rooms or compartments having floor, walls and ceiling with a fire-resistance rating of not less than one hour. Each opening into the rooms or compartments from other parts of the building shall be protected by approved 3/4-hour rated fire door assembly.

(d) Quantities exceeding 500 cubic feet of loose combustible fibers may be stored in an approved 2-hour rated fire-resistive enclosure.

(e) A maximum of 2,500 cubic feet of loose combustible fibers may be stored in a detached storage building located with openings properly protected against entrance of sparks. The storage building may not be used for any other purpose.

(2) BALED STORAGE. (a) A single block or pile may not contain more than 25,000 cubic feet of fiber exclusive of aisles or clearances.

(b) Blocks or piles of baled fiber shall be separated from adjacent storage by aisles not less than 5 feet wide, or by flash fire barriers consisting of continuous sheets of noncombustible material extending from floor to a height of at least one foot above the highest point of piles and projecting at least one foot beyond the sides of the piles.

ILHR 14.182 SPECIAL BALING CONDITIONS. (1) GENERAL. Sisal and other fibers in bales bound with combustible tie ropes, and jute and other fibers liable to swell when wet, shall be stored to allow for expansion in any direction without endangering building walls, ceilings or columns.

(2) MINIMUM DISTANCE. (a) Except as provided in par. (b), a minimum 3-foot clearance shall be left between walls and sides of piles.

(b) A one-foot clearance at side walls shall be sufficient if the storage compartment is not more than 30 feet in width and if a center aisle not less than 5 feet wide is maintained.

Subchapter XXXII - Dust Explosion Hazards

ILHR 14.183 PERMIT REQUIRED. A permit shall be obtained from the fire chief for the operation of any grain elevator or bleacher; flour, starch or feed mill; malt house; wood flour manufacturing plant; or plant pulverizing aluminum, coal, cocoa, magnesium, spices, sugar or other material producing dust which, if mixed with air in the proper portions, becomes explosive and may be ignited by flame or spark.

ILHR 14.184 GENERAL REQUIREMENTS. (1) APPLICATION. Equipment and processes in plants where dust hazards exist shall comply with the requirements of this subchapter. Where specific requirements are not otherwise established, plants producing dusts shall comply with nationally recognized good practice.

(2) MACHINE ENCLOSURES. All dust-producing or dust-agitating machinery such as grinding mills and separators, and all elevators, elevator legs, spouts, hoppers and other conveyors shall be provided with casing or enclosures maintained as nearly dust-tight as possible.

(3) SEPARATORS. Approved magnetic or pneumatic separators shall be installed ahead of all shellers, crackers, crushers, grinding machines, pulverizers and similar machines in which the entrance of foreign materials may cause sparks to be generated.

(4) DUST COLLECTORS. Dust collecting equipment shall be installed and accumulation of dust shall be kept at a minimum in the interior of buildings.

(5) GROUNDING. All machinery and metal parts of the crushing, drying, pulverizing and conveying systems shall be electrically grounded.

ILHR 14.185 FIRE SAFETY REQUIREMENTS. (1) SOURCES OF IGNITION. Smoking and the carrying of matches, the use of heating or other devices employing an open fire, or use of any spark producing equipment shall be prohibited in areas containing dust-producing or dust-agitating operations.

(2) LIGHTING AND ELECTRICAL EQUIPMENT. Artificial lighting in areas containing dust-producing or dust-agitating operations shall be by electricity. All wiring and electrical equipment shall be installed in accordance with the applicable provisions of ch. ILHR 16.

Subchapter XXXIII - Crop Ripening or Coloring Process

ILHR 14.186 PERMIT REQUIRED. A permit shall be obtained from the fire chief for any crop ripening or coloring process.

ILHR 14.187 FIRE SAFETY REQUIREMENTS. (1) ETHYLENE. (a) The location of buildings in which crop ripening or coloring processes are conducted utilizing gas containers of ethylene shall be approved by the fire chief.

(b) The method for introducing ethylene shall provide positive control. The ethylene shall be measured so that the quantity introduced does not exceed one part ethylene to 1,000 parts of air.

(c) Ethylene gas shall be stored in approved containers.

(d) 1. Ethylene gas containers other than those connected for use shall be stored outside of the building or in a special building, except that not more than 2 portable department of transportation containers not connected for use may be stored inside of the building premises.

2. The inside rooms or portions of buildings used for storage of the department of transportation containers shall be of at least 2-hour fire-resistive rated construction and shall have at least one exterior wall.

(e) Ethylene piping shall be of steel pipe. Flexible connectors and hose, when used, shall be an approved type. Tubing shall be of brass or copper with not less than 0.049-inch wall thickness.

(2) ELECTRICAL EQUIPMENT. Electrical wiring and equipment shall be installed as specified in ch. ILHR 16. Artificial lighting shall be by electricity only.

(3) HEATING. (a) Heating of ripening and coloring rooms shall be by indirect means with low pressure steam, hot water or warm air; approved electric heaters; or approved sealed combustion chamber appliances.

(b) Steam and hot water pipes and radiators shall have a clearance of at least one inch to combustible material.

(c) Gas heaters and their vents shall be installed in an approved manner. Gas heaters shall be equipped with an automatic pilot device to shut off the gas supply whenever the flame is extinguished.

(d) Burners for gas or kerosene heaters shall be installed so that air for combustion is taken from outside the ripening or coloring room and the products of combustion are discharged outside the building in an approved manner.

(e) Heaters shall be installed in accordance with the applicable provisions of ch. ILHR 64.

(f) Electric heaters shall be of a type not having an exposed surface at a temperature higher than 800 degrees F and with thermostatic elements which do not produce sparks. They shall be of a type approved for use in hazardous locations.

(g) A protective guard shall be provided around any heater to prevent the possibility of it being knocked over by other equipment such as vehicles or lift trucks.

(4) OPEN FLAMES. Open flame heaters and open lights shall be prohibited in ripening or coloring rooms using ethylene from gas tanks or cylinders. "No Smoking" signs shall be posted at every entrance and smoking shall be prohibited in the ripening or coloring rooms.

(5) HOUSEKEEPING. Rooms for ripening or coloring shall be kept cleared of all combustible material.

Subchapter XXXIV - Fumigation and Thermal Insecticidal Fogging

ILHR 14.188 SCOPE. (1) GENERAL. Except as provided in sub. (2), this subchapter shall apply to all fumigation and thermal insecticidal fogging operations.

(2) EXCEPTION. This subchapter does not apply to the use of those products which are designated as general use pesticides by the US Environmental Protection Agency and are commercially available to the individual consumer.

ILHR 14.189 DEFINITIONS. In this subchapter:

(1) "Fumigant" includes any substance which by itself or in combination with any other substance emits or liberates a gas, fume or vapor used for the destruction or control of insects, fungi, vermin, germs, rats, or other pests, and shall be distinguished from insecticides and disinfectants which are essentially effective in the solid or liquid phases.

Note: Examples of fumigants are methyl bromide, ethylene dibromide, hydrogen cyanide, carbon disulphide and sulfuryl fluoride.

(2) "Fumigation" means the use within an enclosed space of a fumigant in concentrations which may be hazardous or acutely toxic to man.

(3) "Thermal insecticidal fogging" means the use of insecticidal liquids which are passed through thermal fog-generating units where they are, by means of heat, pressure and turbulence, transformed and discharged in the form of a fog or mist that is blown into an area to be treated.

ILHR 14.190 PERMIT REQUIRED. A person shall not perform any fumigation or thermal insecticidal fogging without securing a permit from the fire chief.

ILHR 14.191 FIRE SAFETY REQUIREMENTS. Any building where fumigation and thermal insecticidal fogging operations are conducted shall comply with the fire protection and safety requirements specified in this section.

(1) SOURCES OF IGNITION. All fires, open flames and similar sources of ignition shall be eliminated from the space under fumigation or thermal insecticidal fogging. Heating, if needed, shall be by indirect means with steam or hot water.

(2) ELECTRICITY. Electricity shall be shut off, except that circulating fans may be used provided the fans are designed and installed so as not to create an ignition hazard. Electrical equipment shall be designed and installed in accordance with ch. ILHR 16.

(3) NOTIFICATION. (a) The fire chief shall be notified in writing at least 24 hours before any building or structure is to be closed in connection with the use of any toxic or flammable fumigant.

(b) The notification shall give the location of the building, structure, ship or enclosed space to be fumigated or fogged as well as its character and use, the fumigants or insecticides to be used, the person or persons in charge of the operation and the date and time when it will be started.

(c) Advanced notice of any fumigation or thermal insecticidal fogging shall be served upon the occupants of any building or other enclosed space involved in the operation to enable them to evacuate the premises.

(4) WARNING SIGNS. (a) Suitable warning signs indicating the danger, type of chemical involved and recommended precautions shall be posted on all doors and entrances to the premises and upon all gangplanks and ladders from the deck, pier or land to the ship. The warning sign shall be printed in red ink on white background.

(b) Letters in the headlines are to be at least 2 inches in height and shall state the date and time of the operation, the name and address of the owner, the name of the operator in charge, together with a warning to the effect that the premises so occupied shall be vacated at least one hour before the operation is started and may not be re-entered until the danger signs have been removed by the proper authorities.

(5) BREATHING APPARATUS. All persons engaged in the business of fumigation or thermal insecticidal fogging shall maintain and have available approved protective breathing apparatus.

(6) WATCHPERSON. During the period fumigation is in progress, except when fumigation is conducted in a gas-tight vault or tank, a watchperson shall remain on duty at the entrance or entrances to the building, ship, or enclosed space fumigated until after the fumigation is completed and until the premises are properly ventilated and again safe for human occupancy. Watchpersons shall prevent any person from entering the building, ship or enclosed space under fumigation.

(7) THERMAL INSECTICIDAL FOGGING LIQUIDS. Thermal insecticidal fogging liquids with a flash point below 100 degrees F may not be used.

APPENDIX

The material contained in this appendix is for clarification purposes only. The notes, illustrations, etc. are numbered to correspond to the number of the rule as it appears in the text of this code.

A14.002 (2) (b) Exempt Buildings. The text of this section refers to s. 102.04 (3), Stats., as it relates to the definition of farming. The following is a reprint of s. 102.04 (3), Stats.:

(3) As used in this chapter "farming" means the operation of farm premises owned or rented by the operator. "Farm premises" means areas used for operations herein set forth, but does not include other areas, greenhouses or other similar structures unless used principally for the production of food and farm plants. "Farmer" means any person engaged in farming as defined. Operation of farm premises shall be deemed to be the planting and cultivating of the soil thereof; the raising and harvesting of agricultural, horticultural or arboricultural crops thereon; the raising, breeding, tending, training and management of livestock, bees, poultry, fur-bearing animals, wildlife or aquatic life, or their products, thereon; the processing, drying, packing, packaging, freezing, grading, storing, delivering to storage, to market or to a carrier for transportation to market, distributing directly to consumers or marketing any of the above-named commodities, substantially all of which have been planted or produced thereon; the clearing of such premises and the salvaging of timber and management and use of wood lots thereon, but not including logging, lumbering or wood cutting operations unless conducted as an accessory to other farming operations; the managing, conserving, improving and maintaining of such premises or the tools, equipment and improvements thereon and the exchange of labor, services or the exchange of use of equipment with other farmers in pursuing such activities. The operation for not to exceed 30 days during any calendar year, by any person deriving the person's principal income from farming, of farm machinery in performing farming services for other farmers for a consideration other than exchange of labor shall be deemed farming. Operation of such premises shall be deemed to include also any other activities commonly considered to be farming whether conducted on or off such premises by the farm operator.

A14.020 (2) (d) Fire Inspection Reporting Form. The following is a reproduction of the fire inspection reporting form (SBD-7959). This form or other department approved equivalent must be submitted to the department to fulfill the reporting requirements specified in s. 101.141, Stats.

FIRE DEPARTMENT INSPECTION REPORT

Owner: _____

Owner Address: _____ Telephone: _____

Agent: _____

Agent Address: _____ Telephone: _____

Occupant: _____

Occupant Address: _____ Telephone: _____

Type of Business: _____

Construction: _____

Height: _____ Roof Construction: _____

Fire Appliances: _____

Insurance Carrier: _____

Fire Department Conn: _____

Complaints: _____

Street

Number

Classification

Date of Inspection	Year _____			
	1st Insp	2nd Insp	3rd Insp	4th Insp
1. Aisles				
2. Alarm System				
3. Building Repairs				
4. Burning				
5. Chemicals				
6. Combustibles				
7. Doors				
8. Ducts/Vents				
9. Electricity				
10. Elevators				
11. Exit Lights				
12. Extinguishers				
13. Exits				
14. Explosives				
15. Fire Doors				
16. Fire Escapes				
17. Flameproofing				
18. Flammable Liquids				
19. Housekeeping				
20. Isolation/Enclosure				
21. Open Flame Devices				
22. Paint Spraying				
23. Rubbish/Wastes				
24. Smokepipes				
25. Sprinklers				
26. Stairs				
27. Standpipes/Cabinets				
28. Welding				
29. Other				
30. Inspector				
31. Dept. Violation No				

ADDITIONAL INFORMATION:

A14.020 (2) (c) Written fire reports. The following is a reproduction of the NFIRS fire report form which fire departments are encouraged to use in filing reports with the department. The forms are available from the department at no cost from the following:

Fire Prevention Section
Division of Safety and Buildings
P.O. Box 7969
Madison, Wisconsin 53707
608/266-7874

WISCONSIN FIRE INCIDENT REPORTING SYSTEM

ENTER NAME OF FIRE DEPT.

Main reporting form with sections A through T, including fields for incident details, actions taken, property information, and equipment involved.

COMPLETE FOR ALL INCIDENTS

COMPLETE FOR ALL FIRES

COMPLETE IF STRUCTURE FIRE

WISCONSIN CIVILIAN CASUALTY REPORT FIRE DEPARTMENT

A	5	FDID	Incident No.	Exp. No.	Mo.	Day	Year	Day of Week	Alarm Time

GA	Casualty Number	Casualty Last name	First Name	MI	D.O.B.	Age	Time of Injury
GB	Home Address					Telephone	
GC	SEX	CASUALTY TYPE		SEVERITY		AFFILIATION	
	1 <input type="checkbox"/> Male 2 <input type="checkbox"/> Female	1 <input type="checkbox"/> Fire casualty 2 <input type="checkbox"/> Action Casualty 3 <input type="checkbox"/> EMS Casualty	1 <input type="checkbox"/> Injury 2 <input type="checkbox"/> Death	2 <input type="checkbox"/> Other Emergency Personnel 3 <input type="checkbox"/> Civilian			
GD	Familiarity With Structure		Location of Ignition		Condition Before Injury		
GE	Condition Preventing Escape		Activity at Time of Injury		Cause of Injury		
GF	Nature of Injury		Part of Body Injured		Disposition		
<input type="checkbox"/> See Remarks on Back				<input type="checkbox"/> See Additional Report			

CASUALTY 1

GA	Casualty Number	Casualty Last name	First Name	MI	D.O.B.	Age	Time of Injury
GB	Home Address					Telephone	
GC	SEX	CASUALTY TYPE		SEVERITY		AFFILIATION	
	1 <input type="checkbox"/> Male 2 <input type="checkbox"/> Female	1 <input type="checkbox"/> Fire casualty 2 <input type="checkbox"/> Action Casualty 3 <input type="checkbox"/> EMS Casualty	1 <input type="checkbox"/> Injury 2 <input type="checkbox"/> Death	2 <input type="checkbox"/> Other Emergency Personnel 3 <input type="checkbox"/> Civilian			
GD	Familiarity With Structure		Location of Ignition		Condition Before Injury		
GE	Condition Preventing Escape		Activity at Time of Injury		Cause of Injury		
GF	Nature of Injury		Part of Body Injured		Disposition		
<input type="checkbox"/> See Remarks on Back				<input type="checkbox"/> See Additional Report			

CASUALTY 2

GA	Casualty Number	Casualty Last name	First Name	MI	D.O.B.	Age	Time of Injury
GB	Home Address					Telephone	
GC	SEX	CASUALTY TYPE		SEVERITY		AFFILIATION	
	1 <input type="checkbox"/> Male 2 <input type="checkbox"/> Female	1 <input type="checkbox"/> Fire casualty 2 <input type="checkbox"/> Action Casualty 3 <input type="checkbox"/> EMS Casualty	1 <input type="checkbox"/> Injury 2 <input type="checkbox"/> Death	2 <input type="checkbox"/> Other Emergency Personnel 3 <input type="checkbox"/> Civilian			
GD	Familiarity With Structure		Location of Ignition		Condition Before Injury		
GE	Condition Preventing Escape		Activity at Time of Injury		Cause of Injury		
GF	Nature of Injury		Part of Body Injured		Disposition		
<input type="checkbox"/> See Remarks on Back				<input type="checkbox"/> See Additional Report			

CASUALTY 3

**NFIRS - 2
LAYOUT - 4**

DILHR SBD - 5302 (Rev. 1/84)

T

Officer in Charge (Name, Position, Assignment)	Date
Member Making Report (If Different From Above)	Date

WISCONSIN FIRE SERVICE CASUALTY REPORT

FIRE DEPARTMENT

A	FDID	INCIDENT NO.	EXPOSURE NO.	CASUALTY NO.	INJURY OCCURED	MO	DAY	YEAR	TIME OF INJURY
	CASUALTY NAME (LAST, FIRST, MI)							TYPE OF CASUALTY	
B									
C	AGE	SEX	CASE SEVERITY		PRIMARY APPARENT SYMPTON				
	PRIMARY PART OF BODY			PATIENT TAKEN TO					
D									

E	ASSIGNMENT	NO RESPONSES PRIOR TO INJURY	PHYSICAL CONDITION	STATUS BEFORE ALARM	
	FIRE FIGHTER ACTIVITY		WHERE INJURY OCCURED		
F	CAUSE OF FIRE FIGHTER INJURY		MEDICAL CARE PROVIDED		
G					

H I J K L M N O	PROTECTIVE EQUIPMENT	PROTECTION COAT: WORN	STATUS	TYPE PROBLEM	
		PROTECTIVE PANTS: WORN	STATUS	TYPE PROBLEM	
		BOOTS/SHOES: WORN	STATUS	TYPE PROBLEM	
		HELMET: WORN	STATUS	TYPE PROBLEM	
		FACE PROTECTION: WORN		TYPE PROBLEM	
		BREATHING APPARATUS: WORN	STATUS	TYPE PROBLEM	
		GLOVES: WORN		TYPE PROBLEM	
		SPECIAL EQUIPMENT: WORN	STATUS	TYPE PROBLEM	

P	MEMBER MAKING REPORT	DATE	OFFICER IN CHARGE (NAME, POSITION, ASSIGNMENT)	DATE
	REMARKS			
<input type="checkbox"/> REMARKS CONTINUED ON REVERSE SIDE				

A14.0215 Equipment. The following is a reprint of s. 101.575 (3) (a), Stats., which is referenced in this section:

101.575 (3) (a) No city, village or town may receive fire department dues under this section unless it has a fire department which satisfies all of the following requirements:

1. Is organized to provide continuous fire protection in that city, village or town and has a designated chief.

2. Singly, or in combination with another fire department under a mutual aid agreement, has a total active membership of at least 22 fire fighters and can ensure the response of at least 4 fire fighters, none of whom are the chief, to a first alarm for a building.

3. Provides at least 4 hours of training per month for each active member of the department with fire fighting duties.

4. Provides facilities capable, without delay, of receiving an alarm and dispatching fire fighters and apparatus.

5. Maintains written records as prescribed by the department by rule, in consultation with the fire prevention council.

6. Maintains at least one piece of apparatus which conforms to the general criteria of National Fire Protection Association standard NFPA 1901, automotive fire apparatus. The apparatus shall have a permanently mounted pump capable of delivering 500 gallons per minute or more at 150 pounds per square inch and a water tank with at least a 300-gallon capacity.

7. Maintains any other apparatus or equipment required by the department by rule, in consultation with the fire prevention council.

8. Provides for a building to house the apparatus and equipment required under subs. 6 and 7 which will protect the apparatus and equipment from the weather.

A14.027 PETITION FOR VARIANCE. The following forms (SB-8 and SB-8A) are referred to in this section. Copies of these forms are available from the Division of Safety and Buildings, P.O. Box 7969, Madison, Wisconsin 53707.

POSITION STATEMENT:

To be compiled by
Chief of Fire Department

**WISCONSIN DEPARTMENT OF
INDUSTRY, LABOR AND HUMAN RELATIONS
DIVISION OF SAFETY & BUILDINGS
P.O. BOX 7969 MADISON WI 53707**

Name of Owner	Building Occupancy or Use	Agent, Architect or Engineering Firm
Company	Tenant Name, if any	Street & No.
Street & No.	Building Location, Street & No.	City State & Zip
City State & Zip	City Country	Phone

1. I have read the petition for variance of rule:

2. I recommend (Check appropriate box)	Denial	Approval	Conditional Approval	No Comment*
---	--------	----------	----------------------	-------------

3. Explanation for Recommendation:

* If desired, Fire Departments may indicate "No Comment" on non-fire safety issues such as sanitary, energy conservation, structural, barrier free environments, etc.

4. I find no conflict with local rules and regulations
 I find that the petition is in conflict with local rules and regulations

Explanation

Signature of Fire Chief	Date
-------------------------	------

PLEASE COMPLETE AND SUBMIT PROMPTLY TO DEPARTMENT OF INDUSTRY, LABOR AND HUMAN RELATIONS AT THE ADDRESS SHOWN ABOVE.

A14.(Various) Permits. Various sections of this chapter require the issuance of a permit by the fire chief for different functions or operations. The following is a suggested general permit form which may be utilized by local fire departments in issuing required permits:

 FIRE DEPARTMENT

BUREAU OF FIRE PREVENTION

PERMIT

FOR

ISSUED TO: _____ ADDRESS: _____

PERMIT DATE - FROM: _____ TO: _____

THIS PERMIT IS NOT TRANSFERABLE AND MAY BE REVOKED FOR ANY VIOLATION OF CITY OR STATE CODES, OR FALSE STATEMENTS OR MISREPRESENTATION AS TO A MATERIAL FACT IN THE APPLICATION OR PLANS ON WHICH THE PERMIT OR APPROVAL WAS BASED.

DATE: _____

FIRE DEPARTMENT

A14.102 KINDLING OF FIRE. The following is a reprint of ss. 941.11, 943.02 and 943.03, Stats.:

941.11 UNSAFE BURNING OF BUILDINGS. Whoever does either of the following is guilty of a Class D felony:

(1) Intentionally burns his own building under circumstances in which he should realize he is creating an unreasonable risk of death or great bodily harm to another or serious damage to another's property; or

(2) Intentionally burns a building of one who has consented to the destruction thereof but does so under circumstances in which he should realize he is creating an unreasonable risk of death or great bodily harm to another or serious damage to a third person's property.

943.02 ARSON OF BUILDINGS; DAMAGE OF PROPERTY BY EXPLOSIVES. (1) Whoever does any of the following is guilty of a Class B felony:

(a) By means of fire, intentionally damages any building of another without his consent; or

(b) By means of fire, intentionally damages any building with intent to defraud an insurer of that building; or

(c) By means of explosives, intentionally damages any property of another without his consent.

(2) In this section "building of another" means a building in which a person other than the actor has a legal or equitable interest which the actor has no right to defeat or impair, even though the actor may also have a legal or equitable interest in the building. Proof that the actor recovered or attempted to recover on a policy of insurance by reason of the fire is relevant but not essential to establish his intent to defraud the insurer.

943.03 ARSON OF PROPERTY OTHER THAN BUILDING. Whoever, by means of fire, intentionally damages any property (other than a building) of another without the person's consent, if the property is of the value of \$100 or more, is guilty of a Class E felony.

A14.103 HANDLING OF BURNING MATERIAL. The following is a reprint of ss. 941.10 and 943.05, Stats.:

941.10 NEGLIGENT HANDLING OF BURNING MATERIAL. (1) Whoever handles burning material in a highly negligent manner is guilty of a Class A misdemeanor.

(2) Burning material is handled in a highly negligent manner if, under the circumstances, the person should realize that he creates an unreasonable risk and high probability of death or great bodily harm to another or serious damage to another's property.

943.05 PLACING OF COMBUSTIBLE MATERIALS AN ATTEMPT. Whoever places any combustible or explosive material or device in or near any property with intent to set fire to or blow up such property is guilty of an attempt to violate either s. 943.01, 943.02, 943.03 or 943.04, depending on the facts of the particular case.

A14.106 Incinerators. The following is a partial reprint of NFPA Standard 211 as it relates to incinerators.

Appliances, Industrial

(a) **Low-Heat Industrial Appliance.** An industrial appliance such as a commercial cooking range, pressing machine boiler at any pressure, bake oven, candy furnace, stereotype furnace, drying and curing appliance, and other process appliances in which materials are heated or melted at temperatures (excluding flue-gas temperatures) not exceeding 600°F (316°C). Appliances otherwise classed as medium-heat appliances may be considered as low-heat appliances if not larger than 100 cu ft (2.83 m³) in size excluding any burner equipment and blower compartment.

(b) **Medium-Heat Industrial Appliance.** An industrial appliance such as an annealing furnace (glass or metal), charcoal furnace, galvanizing furnace, gas producer, commercial or industrial incinerator, and steam boiler operating at over 50 psig (345 kPa) pressure when such appliance is larger than 100 cu ft (2.83 m³) in size, and other furnaces classified as medium-heat appliances in accordance with nationally recognized good practice. Appliances otherwise classed as medium-heat appliances may be considered as low-heat appliances if not larger than 100 cu ft (2.83 m³) in size excluding any burner equipment and blower compartment.

(c) **High-Heat Industrial Appliance.** An industrial appliance such as billet and bloom furnace, blast furnace, brass melter, cupola, glass furnace, open-hearth furnace, and ceramic kiln, and vitreous enameling oven (ferrous metals) when such appliances are larger than 100 cu ft (2.83 m³) in size, and other furnaces classified as high-heat appliances in accordance with nationally recognized good practice.

Appliance, Residential-type Heating. Fuel-burning and electric heating appliances, except high-pressure steam boilers, for heating building spaces having a volume of not more than 25,000 cu ft (708 m³) and other heat-producing appliances of the type mainly used in residences, but which may be used in other buildings, such as cooking stoves and ranges, clothes dryers, fireplace stoves, domestic incinerators, laundry stoves, water heaters, and heat pumps.

Chapter 8 Solid Fuel Burning Appliances

8-1 Definitions.

Fireplace Stove. A freestanding, chimney-connected, solid fuel burning appliance designed to be operated with the fire chamber either open or closed.

Room Heater, Solid Fuel. A chimney-connected, solid fuel burning room heater designed to be operated with the fire chamber closed.

8-2 Appliances. Solid fuel burning appliances shall be listed and installed in accordance with the terms of their listing.

Exception: Unlisted appliances approved by the authority having jurisdiction may be installed as specified in this chapter. Such installations shall also be in accordance with the manufacturer's installation instructions if such instructions specify the use of increased protection or greater clearances than specified in this chapter. This exception shall not apply to mobile home installations.

8-3 Location of Appliances.

8-3.1 Every appliance shall be located with respect to building construction and other equipment so as to permit access to the appliance. Sufficient clearance shall be maintained to permit cleaning of surfaces; the replacement of air filters, blowers, motors, controls, and chimney connectors; the lubrication and servicing of moving parts; and the adjustment and servicing of stokers, if provided.

8-3.2 Solid fuel burning appliances shall not be installed in confined spaces. The space or room shall be of ample size to permit adequate circulation of heated air.

Exception: Solid fuel burning appliances listed for installation in confined spaces such as alcoves shall be installed in accordance with the terms of the listing and the manufacturer's instructions.

8-3.3 Solid fuel burning appliances shall not be installed in any location where gasoline or any other flammable vapors or gases are likely to be present.

8-3.4 Solid fuel burning appliances shall not be installed in any residential garage.

8-4 Air for Combustion and Ventilation. Solid fuel burning appliances shall be installed in a location in which the facilities for ventilation permit satisfactory combustion of fuel, proper chimney draft, and maintenance of safe temperature under conditions of use. Appliances shall be so located as not to interfere with proper circulation of air within the heated space. Where buildings are so tight that normal infiltration does not provide the necessary air, outside air shall be introduced.

8-5 Chimney Connections and Usage.

8-5.1 All solid fuel burning appliances shall be connected to chimneys in accordance with Chapter 5. The chimney provided shall be in accordance with Table 1-2(a).

8-5.2 The clearance of chimney connectors to combustible material shall be as specified in Table 5-5(a).

8-5.3 Connectors and chimneys for solid fuel burning appliances shall be designed, located, and installed to permit ready access for internal inspection and cleaning.

8-5.4 For residential-type solid fuel burning appliances, the cross-sectional area of the flue shall not be less than the cross-sectional area of the appliance flue collar. The cross-sectional area of the flue shall not be more than three times the cross-sectional area of the appliance flue collar.

8-6 Mounting.

8-6.1 Mounting for Residential-type Appliances.

8-6.1.1 General Requirements.

8-6.1.1.1 Residential-type solid fuel burning appliances that are tested and listed by a recognized testing laboratory for installation on floors constructed of combustible materials shall be placed on floors in accordance with the requirements of the listing and the conditions of approval. Such appliances that are not listed by a recognized testing laboratory shall be provided with floor protection in accordance with the provisions of 8-6.1.2 or 8-6.1.3.

Exception: Residential-type solid fuel burning appliances are permitted to be placed without floor protection in any of the following manners:

(a) on concrete bases adequately supported on compacted soil, crushed rock, or gravel;

(b) on concrete slabs or masonry arches that do not have combustible materials attached to the underside;

(c) on approved assemblies constructed of only non-combustible materials, and having a fire resistance rating of not less than 2 hrs, with floors constructed of noncombustible material;

(d) on properly stabilized ground that can support the load of the appliance.

8-6.1.1.2 Any floor assembly, slab, or arch shall extend not less than 18 in. (457 mm) beyond the appliance on all sides.

8-6.1.1.3 In lieu of the requirements for floor protection specified herein, a floor protector listed by a recognized testing laboratory and installed in accordance with the installation instructions may be employed.

8-6.1.1.4 Concrete bases, concrete slabs, masonry arches, and floor-ceiling assemblies and their supports shall be designed and constructed to support the appliances.

8-6.2 Mounting for Low-Heat Industrial-type Appliances.

8-6.2.1 Low-heat industrial-type solid fuel burning appliances that have been tested and listed by a recognized testing laboratory for placement on floors constructed with a combustible material shall be placed on floors in accordance with the requirements of the listing and conditions of approval. Such appliances that are not listed by a recognized testing laboratory shall be provided with floor protection in accordance with the provisions of 8-6.2.3 or 8-6.2.4.

Exception: Low-heat industrial-type solid fuel burning appliances are permitted to be placed without floor protection in any of the following manners:

(1) on floors constructed of noncombustible materials and having a fire resistance rating of not less than 2 hrs. This construction shall extend not less than 18 in. (457 mm) beyond the appliance on all sides;

(2) on concrete bases adequately supported on compacted soil, crushed rock, or gravel;

(3) on properly stabilized ground that can support the load of the appliance.

8-6.2.2 Concrete bases, concrete slabs, and floors shall be designed and constructed to support the appliances.

8-6.2.3 Low-heat industrial-type solid fuel burning appliances that are set on legs or pedestals that provide not less than 18 in. (457 mm) of ventilated open space beneath the firechamber or base of the appliance are permitted to be placed on floors of combustible construction provided the floor under the appliance is protected with one course of hollow masonry units not less than 4 in.

(102 mm) in thickness. The masonry units shall be laid with ends unsealed and joints matched in such a way as to provide free circulation of air through the core spaces of the masonry. The top surface of the masonry shall be covered with a steel plate not less than $\frac{3}{16}$ in. (4.8 mm) in thickness. The floor protection shall extend not less than 18 in. (457 mm) beyond the appliance on all sides.

8-6.2.4 Low-heat industrial-type solid fuel burning appliances that are set on legs or pedestals that provide 6 to 18 in. (152 to 457 mm) of ventilated open space beneath the firechamber or base of the appliance are permitted to be placed on floors of combustible construction provided the floor under the appliance is protected with two courses of hollow masonry units, each not less than 4 in. (102 mm) in thickness. The masonry units shall be laid with ends unsealed and joints matched in such a way as to provide a free circulation of air through the core spaces of the masonry. The top surface of the masonry shall be covered with a steel plate not less than $\frac{3}{16}$ in. (4.8 mm) in thickness. The floor protection shall extend not less than 18 in. (457 mm) beyond the appliance on all sides.

8-6.2.5 Low-heat industrial-type solid fuel burning appliances with legs or pedestals that provide less than 6 in. (152 mm) of ventilated open space beneath the firechamber or base of the appliance shall not be placed on floors of combustible construction.

8-6.3 Mounting for Medium-Heat Industrial-type Appliances.

8-6.3.1 Medium-heat industrial-type solid fuel burning appliances that have been tested and listed by a recognized testing laboratory for placement on floors constructed with a combustible material shall be placed on floors in accordance with the requirements of the listing and conditions of approval. Such appliances that are not listed by a recognized testing laboratory shall be provided with floor protection in accordance with the provisions of 8-6.3.

Exception: Medium-heat industrial-type solid fuel burning appliances are permitted to be placed without floor protection in any of the following manners:

(1) on concrete bases adequately supported on compacted soil, crushed rock, or gravel;

(2) on floors constructed of noncombustible materials and having a fire resistance rating of not less than 2 hrs. This construction shall extend not less than 3 ft (0.92 m) beyond the appliance on all sides and 8 ft (2.45 m) beyond the front or side where ashes are removed;

(3) on properly stabilized ground that can support the load of the appliance.

8-6.3.2 Concrete bases, concrete slabs, and floors shall be designed and constructed to support the appliances.

8-6.3.3 Medium-heat industrial-type solid fuel burning appliances that are set on legs or pedestals that provide not less than 24 in. (610 mm) of ventilated open space beneath the firechamber or base of the appliance are permitted to be placed on floors of combustible construction provided the floor under the appliance is protected with one course of hollow masonry units not less than 4 in. (102 mm) in thickness. The masonry units shall be laid

with ends unsealed and joints matched in such a way as to provide a free circulation of air through the core spaces of the masonry. The top surface of the masonry shall be covered with a steel plate not less than $\frac{3}{16}$ in. (4.8 mm) in thickness. The floor protection shall extend not less than 3 ft (0.92 m) beyond the appliance on all sides and 8 ft (2.45 m) beyond the front or side where ashes are removed.

8-6.3.4 Medium-heat industrial-type solid fuel burning appliances that are set on legs or pedestals that provide 18 to 24 in. (457 to 610 mm) of ventilated open space beneath the firechamber or base of the appliance are permitted to be placed on floors of combustible construction provided the floor under the appliance is protected with two courses of hollow masonry units, each not less than 4 in. (102 mm) in thickness. The masonry units shall be laid with ends unsealed and joints matched in such a way as to provide a free circulation of air through the core spaces of the masonry. The top surface of the masonry shall be covered with a steel plate not less than $\frac{3}{16}$ in. (4.8 mm) in thickness. The floor protection shall extend not less than 3 ft (0.92 m) beyond the appliance on all sides and 8 ft (2.45 m) beyond the front or side where ashes are removed.

8-6.3.5 Medium-heat industrial-type solid fuel burning appliances with legs or pedestals that provide less than 18 in. (457 mm) of ventilated open space beneath the firechamber or base of the appliance shall not be placed on floors of combustible construction.

8-6.4 Mounting of High-Heat Industrial-type Appliances.

8-6.4.1 High-heat industrial-type solid fuel burning appliances shall be placed in one of the following manners:

(1) on concrete bases adequately supported on compacted soil, crushed rock, or gravel;

(2) on floors constructed of noncombustible materials and having a fire resistance rating of not less than 2 hrs. This construction shall extend not less than 10 ft (3.1 m) beyond the appliance on all sides and not less than 30 ft (9.2 m) beyond the front or side where hot products are removed;

(3) on properly stabilized ground that can support the load of the appliance.

8-6.4.2 Concrete bases and floors shall be designed and constructed to support the appliances.

8-6.4.3 High-heat industrial-type solid fuel burning appliances shall not be placed on floors of combustible construction.

8-7 Clearances.

8-7.1 Solid fuel burning appliances shall be installed so that their use will not create a hazard to person or property. The clearance shall be not less than specified in Table 8-7(a).

Exception No. 1: Appliances listed for installation with clearances less than specified in Table 8-7(a) may be installed in accordance with the terms of their listing and the manufacturer's instructions.

Exception No. 2: Heating furnaces and boilers and water heaters specifically listed for installation in spaces such as alcoves may be so installed in accordance with the terms of their listing provided the specified clearance is maintained regardless of whether the enclosure is of combustible or noncombustible material.

Table 8-7(a)
Standard Clearances for Solid Fuel Burning Appliances

For Reduced Clearances, see Table 8-7(b).
These clearances apply to appliances installed in rooms which are large in comparison with the size of the appliances.

Kind of Appliance	Above Top of Casing or Appliance.	From Front in./mm	From Back ¹ in./mm	From Sides ¹ in./mm
	Above Top and Sides of Furnace Plenum or Bonnet in./mm			
Residential Appliances	6/152	48/1219	6/152 ²	6/152 ²
Steam Boilers — 15 psi				
Water Boilers — 250°F max.				
Water Boilers — 200°F max.				
All Water Walled or Jacketed.				
Furnaces				
Gravity and Forced Air ⁴	18/457	48/1219	18/457	18/457
Room Heaters, Fireplace Stoves, Combinations	36/914	36/914	36/914	36/914
Ranges			Firing Side	Opp. Side
Lined Firechamber	30/762 ¹	36/914	24/610	18/457
Unlined Firechamber	30/762 ¹	36/914	36/914	18/457

¹To combustible material or metal cabinets. If the underside of such combustible material or metal cabinet is protected with sheet metal of not less than (0.024 in.)(0.610 mm) 24 gage spaced out in 1 in. (25.4 mm), the distance may be reduced to not less than 24 in. (610 mm).

8-7.2 Clearances from Solid Fuel Burning Appliances.

8-7.2.1 Clearances from listed and unlisted solid fuel burning appliances to combustible material may be reduced if the combustible material is protected as described in Table 8-7(b) and in Figures 8-7(a) to 8-7(d).

8-7.2.2 Clearances from solid fuel burning appliances to combustible material may be reduced if the combustible material is protected by an engineered protection system acceptable to the authority having jurisdiction. Engineered systems installed for the protection of combustible material shall reduce the temperature of such materials to 90°F (50°C) rise above ambient. System design shall be based upon applicable heat transfer principles taking into account the geometry of the system, the heat loss characteristics of the structure behind the combustible material, and possible abnormal operating conditions of the heat-producing sources.

8-7.2.3 Clearances from solid fuel burning appliances to combustible material may be reduced by the use of materials or products listed for protection purposes.

Table 8-7(b) Reduction of Appliance Clearance with Specified Forms of Protection^{1,2,3,4,5,6,7,8,9,10}

Clearance reduction system applied to and covering all combustible surfaces within the distance specified as required clearance with no protection (see Section 8-7.1).	Maximum allowable reduction in clearance (percent)		When the required clearance with no protection is 36 in., the clearances below are the minimum allowable clearance. For other required clearances with no protection, calculate minimum allowable clearance from maximum allowable reduction. ^{9,10}	
	As Wall Protector	As Ceiling Protector	As Wall Protector (in./mm)	As Ceiling Protector (in./mm)
(a) 3½ in. (90 mm) thick masonry wall without ventilated air space.	33%	—	24/610	—
(b) ½ in. (13 mm) thick noncombustible insulation board over 1 in. (25 mm) glass fiber or mineral wool batts without ventilated air space.	50%	33%	18/457	24/610
(c) 0.024 in./0.61 mm (24 gage) sheet metal over 1 in. (25 mm) glass fiber or mineral wool batts reinforced with wire, or equivalent, on rear face with ventilated air space	66%	50%	12/305	18/457
(d) 3½ in. (90 mm) thick masonry wall with ventilated air space	66%	—	12/305	—
(e) 0.024 in./0.61 mm (24 gage) sheet metal with ventilated air space.	66%	50%	12/305	18/457
(f) ½ in. (13 mm) thick noncombustible insulation board with ventilated air space.	66%	50%	12/305	18/457
(g) 0.024 in./0.61 mm (24 gage) sheet metal with ventilated air space over 0.024 in./0.61 mm (24 gage) sheet metal with ventilated air space.	66%	50%	12/305	18/457
(h) 1 in. (25 mm) glass fiber or mineral wool batts sandwiched between two sheets 0.024 in./0.61 mm (24 gage) sheet metal with ventilated air space.	66%	50%	12/305	18/457

¹Spacers and ties shall be of noncombustible material. No spacers or ties shall be used directly behind appliance or conductor.

²With all clearance reduction systems using a ventilated air space, adequate air circulation shall be provided as described in 8-7.2.4. There shall be at least 1 in. (25 mm) between the clearance reduction system and combustible walls and ceilings for clearance reduction systems using a ventilated air space.

³Mineral wool batts (blanket or board) shall have a minimum density of 8 lb per ft³ (128.7 kg/m³) and have a minimum melting point of 1500°F (816°C).

⁴Insulation material used as part of clearance reduction system shall have a thermal conductivity of 1.0 (Btu-in.)/(sq ft-hr-°F) or less. Insulation board shall be formed of noncombustible material.

⁵If a single wall connector passes through a masonry wall used as a wall shield, there shall be at least ½ in. (13 mm) of open, ventilated air space between the connector and the masonry.

⁶There shall be at least 1 in. (25 mm) between the appliance and the protector. In no case shall the clearance between the appliance and the wall surface be reduced below that allowed in the table.

⁷Clearances in front of the loading door and/or ash removal door of the appliance shall not be reduced from those in Section 8-6.

⁸All clearances and thicknesses are minimums; larger clearances and thicknesses are acceptable. Clearances are not to be less than 12 in. (305 mm) from appliances.

⁹To calculate the minimum allowable clearance, the following formula may be used: $C_{pr} = C_{un} \times (1 - R/100)$. C_{pr} is the minimum allowable clearance, C_{un} is the required clearance with no protection, and R is the maximum allowable reduction in clearance.

¹⁰Refer to Figures 8-7(f) and 8-7(g) for other reduced clearances using materials (a) through (h).

Materials and products listed for the purpose of reducing clearance to combustibles shall be installed in accordance with the conditions of the listing and the manufacturer's instructions.

8-7.2.4 For clearance reduction systems using an air space between the combustible wall and the wall protector, adequate air circulation shall be provided by one of the following methods as shown in Figure 8-7(e).

8-7.2.4.1 Adequate air circulation may be provided by leaving all edges of the wall protector open with at least a 1-in. (25.4-mm) air gap.

8-7.2.4.2 If the wall protector is mounted on a single flat wall away from corners, adequate air circulation may be provided by leaving only the bottom and top edges or only the side and top edges open with at least a 1-in. (25.4-mm) air gap.

8-7.2.4.3 Wall protectors that cover two walls in a corner shall be open at the bottom and top edges with at least a 1-in. (25.4-mm) air gap.

8-7.2.5 All clearances shall be measured from the outer surface of the combustible material to the nearest point on the surface of the solid fuel burning appliance, disregarding any intervening protection applied to the combustible material.

8-7.2.6 All clearances provided between solid fuel burning appliances and combustible materials shall be large enough to maintain sufficient clearances between chimney connectors and combustible material as required in Section 5-5.

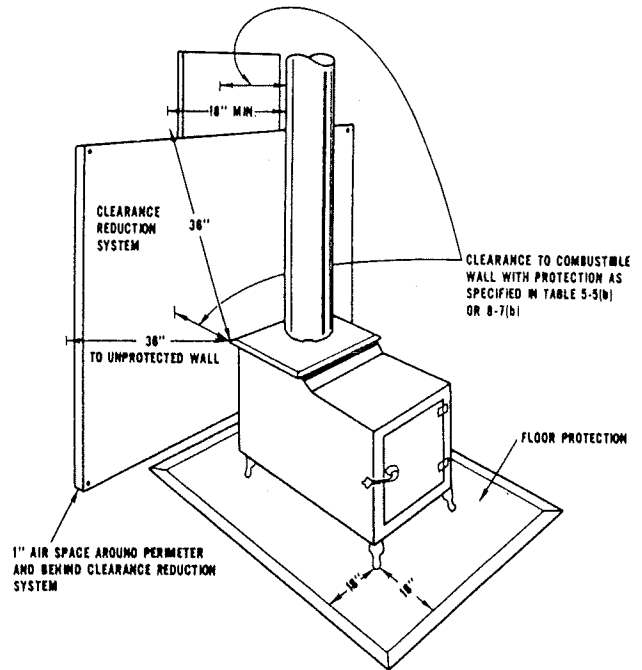

For SI Units: 1 in. = 25.4 mm.

Figure 8-7(b).

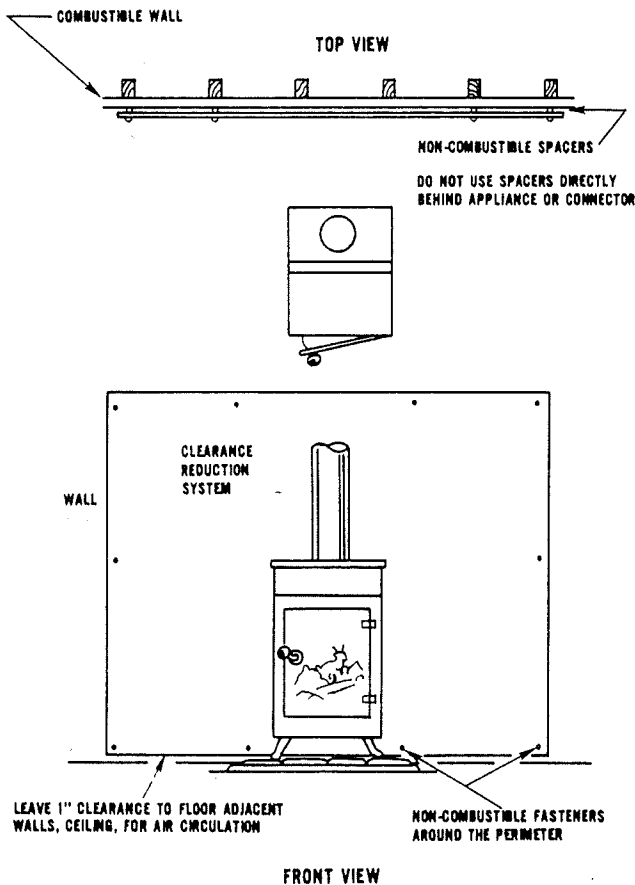

For SI Units: 1 in. = 25.4 mm.

Figure 8-7(a).

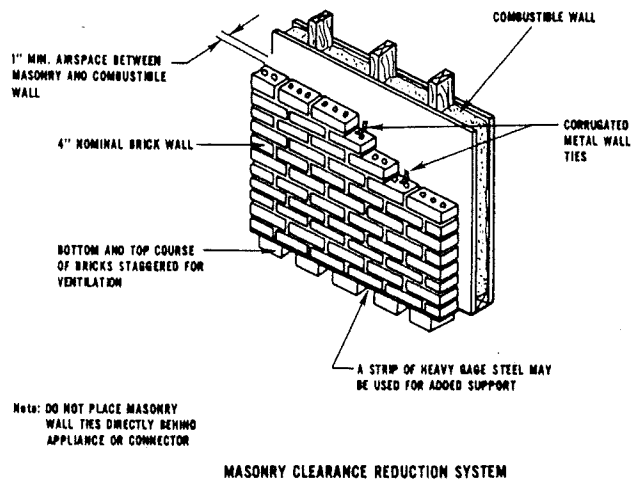

For SI Units: 1 in. = 25.4 mm.

Figure 8-7(c).

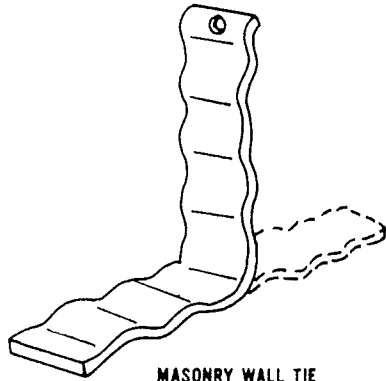

MASONRY WALL TIE

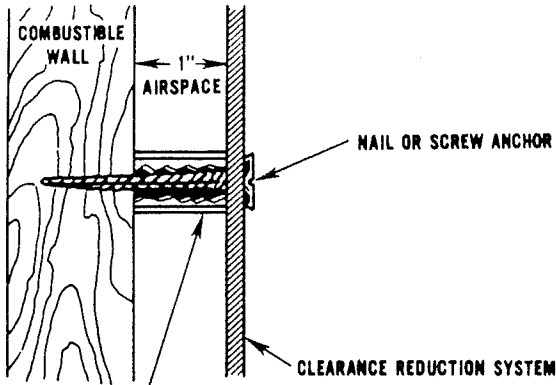

1" NON-COMBUSTIBLE SPACER SUCH AS STACKED WASHERS, SMALL DIAMETER PIPE, TUBING, OR ELECTRICAL CONDUIT.
 MASONRY WALLS MAY BE ATTACHED TO COMBUSTIBLE WALLS USING WALL TIES.
 DO NOT USE SPACERS DIRECTLY BEHIND APPLIANCE OR CONNECTOR.

For SI Units: 1 in. = 25.4 mm.

Figure 8-7(d).

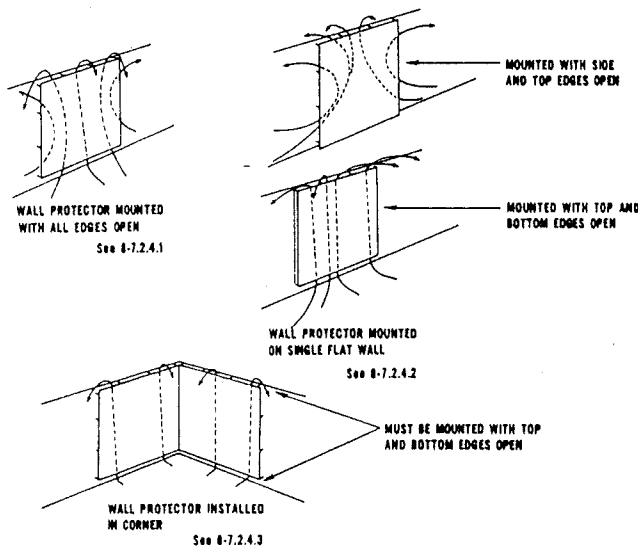

Figure 8-7(e).

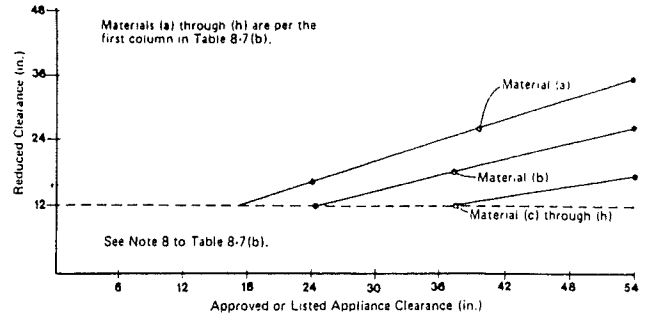

Figure 8-7(f) Wall Protection Using Materials in Table 8-7(b).

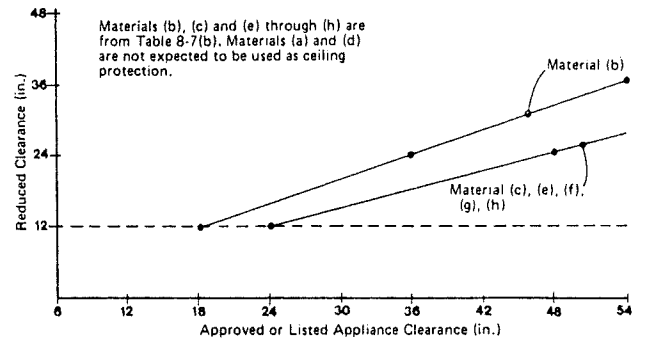

Figure 8-7(g) Ceiling Protection Using Materials in Table 8-7(b).

8-8 Accessories. Factory-built accessories for solid fuel burning appliances such as heat exchangers, stove mats, floor pads, and protection shields shall be listed and shall be installed in accordance with the terms of their listing.
Exception: Unlisted accessories that are acceptable to the authority having jurisdiction may be installed in accordance with the approval and the manufacturer's installation instruction.

A14.110 (2) (b) Storage Areas - Automatic Fire Sprinkler System Protection. The following is a reprint of s. 4-2.5.1 of the NFPA Standard is:

4-2.5 Clear Space Below Sprinklers.

4-2.5.1 A minimum of 18 inches (457 mm) clearance shall be maintained between top of storage and ceiling sprinkler deflectors. For in-rack sprinklers, the clear space shall be accordance with NFPA 231C, Rack Storage of Materials.

A14.110 (2) (c) Clearances to electrical equipment. The following is a reprint of s. 110.16 of the National Electrical Code:

110-16. WORKING SPACE ABOUT ELECTRIC EQUIPMENT (600 VOLTS, NOMINAL, OR LESS). Sufficient access and working space shall be provided and maintained about all electric equipment to permit ready and safe operation and maintenance of such equipment.

(a) Working clearances. Except as elsewhere required or permitted in this Code, the dimension of the working space in the direction of access to live parts operating at 600 volts, nominal, or less and likely to require examination, adjustment, servicing, or maintenance while energized shall not be less than indicated in Table 110-16 (a). Distances shall be measured from the live parts if such are exposed or from the enclosure front or opening if such are enclosed. Concrete, brick, or tile walls shall be considered as grounded.

In addition to the dimension shown in Table 110-16 (a), the work space shall not be less than 30 inches (762 mm) wide in front of the electric equipment. In all cases the work space shall permit at least a 90-degree opening of equipment doors or hinged panels.

TABLE 110-16 (a) WORKING CLEARANCES

Voltage to Ground, Nominal	Minimum Clear Distance (feet)			
	Condition:	1	2	3
0-150		3	3	3
151-600		3	3 1/2	4

For SI units: one inch = 25.4 millimeters; one foot = 0.3048 meter.

Where the "Conditions" are as follows:

1. Exposed live parts on one side and no live or grounded parts on the other side of the working space, or exposed live parts on both sides effectively guarded by suitable wood or other insulating materials. Insulated wire or insulated busbars operating at not over 300 volts shall not be considered live parts.

2. Exposed live parts on one side and grounded parts on the other side.

3. Exposed live parts on both sides of the work space (not guarded as provided in Condition 1) with the operator between.

Exception No. 1: Working space shall not be required in back of assemblies such as dead-front switchboards, or motor control centers where there are no renewable or adjustable parts such as fuses or switches on the back and where all connections are accessible from locations other than the back.

Exception No. 2: By special permission smaller spaces may be permitted (1) where it is judged that the particular arrangement of the installation will provide adequate accessibility, or (2) where all uninsulated parts are at a voltage no greater than 30 volts RMS or 42V dc.

(b) Clear Spaces. Working space required by this section shall not be used for storage. When normally enclosed live parts are exposed for inspection or servicing, the working space, if in a passageway or general open space, shall be suitably guarded.

(c) Access and Entrance to Working Space. At least one entrance of sufficient area shall be provided to give access to the working space about electrical equipment. For switchboards and control panels rated 1200 amperes or more and over 6 feet (1.83 m) wide, there shall be one entrance not less than 24 inches (610 mm) wide and 6 1/2 feet (1.98 m) high at each end.

Exception No. 1: Where the switchboards and panelboards location permits a continuous and unobstructed way of exit travel.

Exception No. 2: Where the work space required by Section 110-16 (a) is doubled only one entrance to the working space is required. Working space with one entrance provided shall be so located that the edge of the entrance nearest the switchboards and panelboards is the minimum clear distance given in Table 110-16 (a) away from such equipment.

(d) Front Working Space. In all cases where there are live parts normally exposed on the front of switchboards or motor control centers, the working space in front of such equipment shall not be less than 3 feet (914 mm).

(e) Illumination. Illumination shall be provided for all working spaces about service equipment, switchboards, panelboards, or motor control centers installed indoors.

Exception: Service equipment or panelboards, in dwelling units, that do not exceed 200 amperes.

(f) Headroom. The minimum headroom of working spaces about service equipment, switchboards, panelboards, or motor control centers shall be 6-1/4 feet (1.91 m).

Exception: Service equipment or panelboards, in dwelling units, that do not exceed 200 amperes.

(FPN): For higher voltages, see Article 710.

(FPN): As used in this section, a motor control center is an assembly of one or more enclosed sections having a common power bus and principally containing motor control units.

A 14.110 (3) (a) 4. 'Outside storage'. The following diagram illustrates a typical sample layout of piles and driveways that satisfies the requirement.

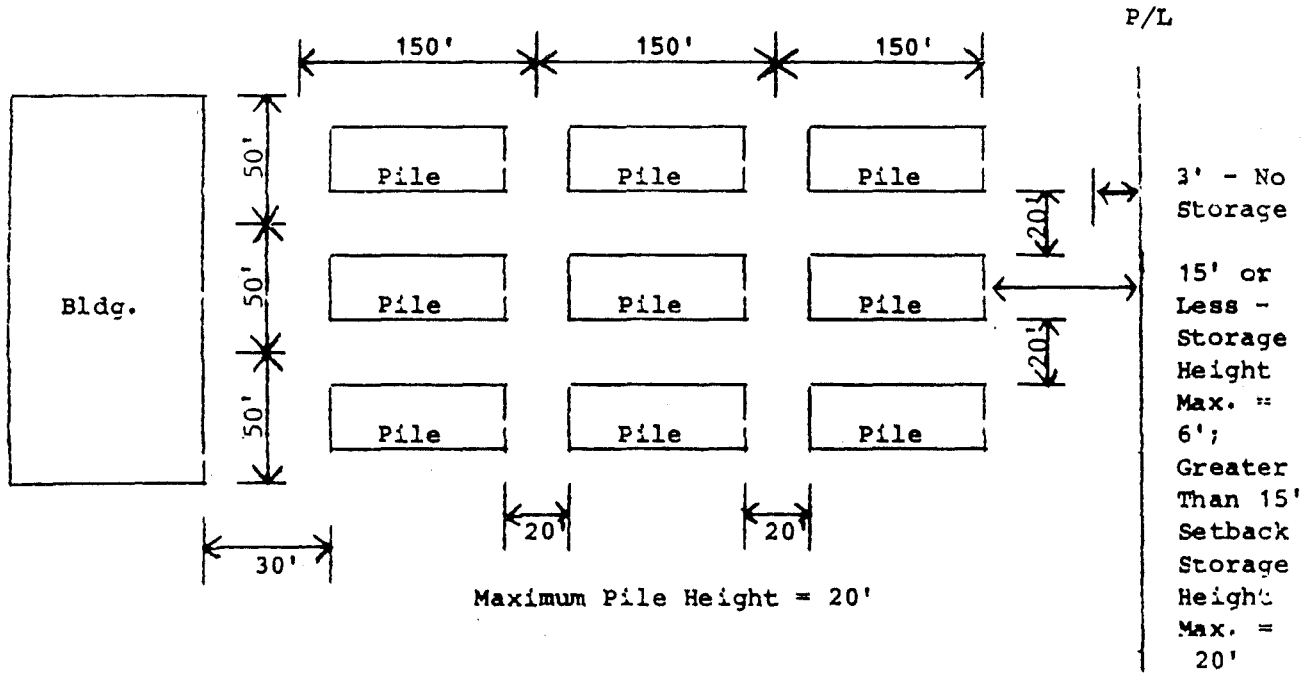

A14.114 PROHIBITION OF SMOKING. The following is a reprint of Ch. ILHR 4 - Signs for Smoking Areas, which includes a reprint of s. 101.125, Stats:

Wisconsin Administrative Code

Rules of DEPARTMENT OF INDUSTRY, LABOR AND HUMAN RELATIONS

SIGNS FOR SMOKING AREAS

Cite the rules in this Code as

(for example)

s. ILHR 4.01, Wis. Adm. Code

**DEPARTMENT OF INDUSTRY, LABOR AND
HUMAN RELATIONS**

201 East Washington Avenue

Madison, Wisconsin 53702

608-266-3151

INTRODUCTION

Purpose and Structure

The legislature, by s. 35.93 and ch. 227, Stats., directed the publication of the rules of administrative agencies having rule-making authority in a loose-leaf, continual revision system known as the Wisconsin Administrative Code. The code is kept current by means of new and replacement pages. The pages are issued monthly, together with notices of hearings, notices of proposed rules, emergency rules, new rules, instructions for insertion of new material, and other information relating to administrative rules. This service is called the Wisconsin Administrative Register, and comes to the subscriber after the 10th and the 25th of each month. Code pages are issued to subscribers only with the end of the month Register. The editing and publishing of the Register and Code is done by the Revisor of Statutes Bureau, 411 W. State Capitol, Madison, Wisconsin, 53702. (608-266-7275).

Availability

The complete code and the upkeep service are distributed to the county law libraries; to the libraries of the University of Wisconsin Law School and Marquette University Law School; to the State Historical Society; to the Legislative Reference Bureau and to the State Law Library, and to certain designated public libraries throughout the state.

The sale and distribution of the Register, Code and of its parts is handled by Department of Administration, Document Sales and Distribution, 202 S. Thornton Ave., Madison, Wisconsin 53702. (608-266-3358)

Table of Contents

Each code with more than one chapter will have a table of chapters. After the title of each chapter will be the page numbers on which the chapter begins. Each chapter will have a table of sections. When a chapter has more than 10 sections and is over 10 pages in length the page number which that particular section begins on will be inserted after the title of the section.

History Notes

Each page of the code as it was originally filed and printed pursuant to the 1955 legislation, is dated "1-2-56". A rule which is revised or created subsequent to the original printing date is followed by a history note indicating the date and number of the Register in which it was published and the date on which the revision or creation of the rule became effective. The absence of a history note at the end of a section indicates that the rule has remained unchanged since the original printing in 1956. The date line at the bottom of the page indicates the month in which the page was released. Some common abbreviations used in the history notes are: cr. - created, am. - amend, r. - repeal, recr. - recreate, renum. - renumber, eff. - effective and emerg. - emergency.

In some instances an *entire* chapter has been repealed and recreated or renumbered subsequent to the original printing date. When this occurs a history note has been placed at the beginning of the chapter to contain this information. A separate history note appears after each section indicating the date when the revision became effective.

Index

The index for the complete Wisconsin Administrative Code will be found in the last volume. It will be recompiled, reprinted and distributed annually. Some codes have a separate index prepared by the agency involved. See the Building and Heating Code (chs. ILHR 50-64) for an example.

INDUSTRY, LABOR & HUMAN RELATIONS 1
ILHR 4

Chapter ILHR 4

SIGNS FOR SMOKING AREAS

ILHR 4.01 Purpose
ILHR 4.02 Signs

ILHR 4.03 Petition for variance
ILHR 4.04 Penalties

ILHR 4.01 Purpose. Pursuant to s. 101.123 (6), Stats., the purpose of this chapter is to specify uniform dimensions and other characteristics of signs used to designate smoking areas.

Note: See Appendix for a reprint of s. 101.123, Stats.

History: Cr. Register, September, 1984, No. 345, eff. 10-1-84.

ILHR 4.02 Signs. (1) **WORDING.** The signs used to designate smoking areas shall contain the words "Smoking Allowed" or "Smoking Permitted".

(2) **CHARACTER SPECIFICATIONS.** The letters shall be at least $\frac{3}{4}$ inch in height and shall have a width:height ratio between 3:5 and 1:1 and a stroke-width:height ratio between 1:4 and 1:10.

Note: See Appendix for further explanatory information.

(3) **INTERNATIONAL SYMBOL.** Signs shall include the international symbol for smoking allowed. The symbol shall be at least $2\frac{1}{2}$ inches in each dimension.

Note: See Appendix for further explanatory information.

(4) **CHARACTERS CONTRAST AND BACKGROUND.** The signs shall have either light characters on a dark background or dark characters on a light background.

Note: Research has indicated that yellow on black, white on black and white on green provide the most easily visible color contrasts.

(5) **AFFIXING.** Signs shall be securely affixed and, where posted outdoors, shall be weather-resistant.

(6) **STATUTORY CITATION.** Signs may include, in letters of any size, the words "In accordance with section 101.123, Wisconsin Statutes".

Note: See Appendix for an example of a sign which meets these requirements.

(7) **OTHER SIGNS.** In addition to the signs required under s. 101.123 (4) (b), Stats., individual signs may be placed on tables and desks to designate "smoking allowed" or "smoking permitted" areas. The signs may be proportionate reductions of the signs specified in subs. (1) to (6).

History: Cr. Register, September, 1984, No. 345, eff. 10-1-84.

ILHR 4.03 Petition for variance. (1) **PROCEDURE.** The department of industry, labor and human relations shall consider and may grant a variance to s. ILHR 4.02 upon receipt of a completed petition for variance form from the owner, provided an equivalency is established in the petition for variance which meets the intent of the rule being petitioned. The department may impose specific conditions in granting a variance to promote the protection of the health, safety and welfare of the employes or

Register, September, 1984, No. 345

2 WISCONSIN ADMINISTRATIVE CODE

ILHR 1

the public. Violation of those conditions under which the variance is granted shall constitute a violation of this chapter. The cost for processing petitions for variance shall be \$50.

Note 1: Copies of the petition for variance (form SB-8) are available at no charge from the Division of Safety and Buildings, P.O. Box 7969, Madison, Wisconsin 53707.

Note 2: Section 101.02 (6), Stats., outlines the procedure for submitting petitions to the department and the department procedures for hearing petitions.

(2) **PETITION PROCESSING TIME.** The department of industry, labor and human relations shall review and make a determination on a petition for variance within 15 business days of receipt of all information necessary to complete the review.

History: Cr. Register, September, 1984, No. 345, eff. 10-1-84.

ILHR 4.04 Penalties. After April 1, 1985, any person who wilfully fails to comply with the rules of this chapter shall forfeit not more than \$25.

History: Cr. Register, September, 1984, No. 345, eff. 10-1-84.

INDUSTRY, LABOR & HUMAN RELATIONS 3
Appendix

APPENDIX

The material contained in the Appendix is for clarification purposes only. The material is numbered to correspond to the number of the rule as it appears in the text of the code.

A 4.01 PURPOSE. The following is a reprint of 1983 Wisconsin Act 211 which created s. 101.123, Stats.:

STATE OF WISCONSIN

1983 Senate Bill 80

Date of enactment: April 18, 1984
Date of publication*: April 25, 1984

1983 Wisconsin Act 211

AN ACT to create 101.123 of the statutes, relating to regulating smoking in public conveyances and specified places, granting rule-making authority and providing a penalty.

The people of the state of Wisconsin, represented in senate and assembly, do enact as follows:

SECTION 1. 101.123 of the statutes is created to read

101.123 Clean indoor air. (1) DEFINITIONS. In this section

(a) "Educational facility" means any building used principally for educational purposes in which a school is located or a course of instruction or training program is offered that has been approved or licensed by a state agency or board.

(b) "Inpatient health care facility" has the meaning provided under s. 140.86 (1), except that it does include community-based residential facilities as defined under s. 50.01 (1).

(c) "Office" means any area that serves as a place of work at which the principal activities consist of professional, clerical or administrative services.

(d) "Person in charge" means the person who ultimately controls, governs or directs the activities aboard a public conveyance or within a place where smoking is regulated under this section, regardless of the person's status as owner or lessee.

(e) "Public conveyance" means mass transit vehicles as defined by s. 340.01 (28q) and school busses as defined by s. 340.01 (56).

(f) "Restaurant" means an establishment defined in s. 50.50 (3) with a seating capacity of more than 50 persons.

(g) "Retail establishment" means any store or shop in which retail sales is the principal business conducted, except a tavern operating under a "Class B" intoxicating liquor license or Class "B" fermented malt beverages license, and except bowling alleys.

(h) "Smoking" means carrying a lighted cigar, cigarette, pipe or any other lighted smoking equipment.

(2) REGULATION OF SMOKING. (a) Except as provided in sub. (3), no person may smoke in the following places:

1. Public conveyances.
2. Educational facilities.
3. Inpatient health care facilities.
4. Indoor movie theaters.
5. Offices.
6. Passenger elevators.
7. Restaurants.
8. Retail establishments.
9. Public waiting rooms.
10. Any enclosed, indoor area of a state, county, city, village or town building.

4 WISCONSIN ADMINISTRATIVE CODE
Appendix

- 2 -

1983 Senate Bill 80

- (b) The prohibition in par. (a) applies only to enclosed indoor areas.
- (c) This section does not limit the authority of any county, city, village or town to enact ordinances or of any school district to adopt policies that, complying with the purpose of this section, protect the health and comfort of the public.
- (3) EXCEPTIONS. The regulation of smoking in sub. (2) does not apply to the following places:
- (a) Areas designated smoking areas under sub. (4).
 - (b) Offices occupied exclusively by smokers.
 - (c) Entire rooms or halls used for private functions, if the arrangements for the function are under the control of the sponsor of the function.
 - (d) Restaurants holding a "Class B" intoxicating liquor or Class "B" fermented malt beverage license if the sale of intoxicating liquors or fermented malt beverages or both accounts for more than 50% of the restaurant's receipts.
 - (e) Offices that are privately owned and occupied.
 - (f) Any area of a facility used principally to manufacture or assemble goods, products or merchandise for sale.
 - (g) Prisons, secured correctional facilities, secure detention facilities, jails and lockup facilities.
- (4) DESIGNATION OF SMOKING AREAS. (a) A person in charge or his or her agent may designate smoking areas in the places where smoking is regulated under sub. (2) unless a fire marshal, law, ordinance or resolution prohibits smoking. Entire rooms and buildings may be designated smoking areas.
- (b) If an entire room is designated a smoking area, the person in charge or his or her agent shall post notice of the designation conspicuously on or near all entrances to the room normally used by the public. If an entire building is designated a smoking area, notice of the designation shall be posted on or near all entrances to the building normally used by the public, but posting notice of the designation on or near entrances to rooms within the building is not required.
 - (c) The person in charge or his or her agent shall utilize, if possible, existing physical barriers and ventilation systems when designating smoking areas. This paragraph requires no new construction of physical barriers or ventilation systems in any building.
 - (d) This section requires the posting of signs only in areas where smoking is permitted.
- (5) RESPONSIBILITIES. The person in charge or his or her agent shall
- (a) Post signs identifying designated smoking areas, and
 - (b) Arrange seating to accommodate nonsmokers if smoking areas are adjacent to nonsmoking areas.
- (6) UNIFORM SIGNS. The department shall, by rule, specify uniform dimensions and other characteristics of signs used to designate smoking areas. These rules may not require the use of signs that are more expensive than is necessary to accomplish their purpose.
- (7) SIGNS FOR STATE AGENCIES. The department shall arrange with the department of administration to have the signs prepared and made available to state agencies for use in state facilities.
- (8) PENALTIES. (a) On and after the first day of the 12th month commencing after the effective date of this section (1983), any person in charge or his or her agent who willfully fails to comply with sub. (5) shall forfeit not more than \$25.
- (b) Sections 101.02 (13) (a) and 939.61 (1) do not apply to this section.
 - (c) A violation of this section does not constitute negligence as a matter of law.
- (9) INJUNCTION. After July 1, 1985, state or local officials or any affected party may institute an action in any court with jurisdiction to enjoin repeated violations of this section.

INDUSTRY, LABOR & HUMAN RELATIONS 5
Appendix

A 4.02 The following is a SAMPLE sign which conforms to the specifications outlined in this section:

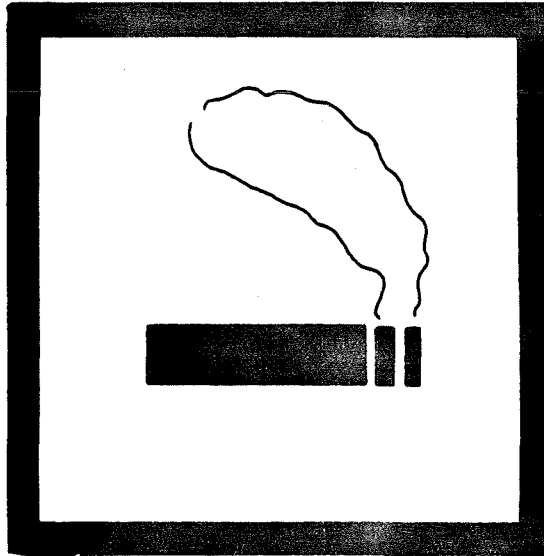

**SMOKING
ALLOWED**

SECTION 101.123(4), WIS. STATS.

6 WISCONSIN ADMINISTRATIVE CODE

Appendix

A 4.02 (2) The following diagram illustrates character ratio requirements.

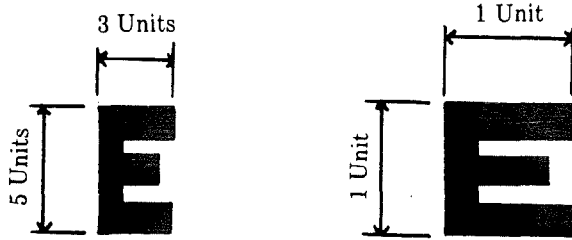

Width:Height Ratio

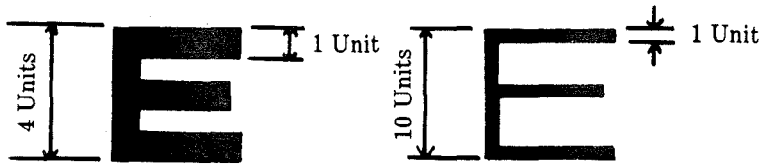

Stroke-Width:Height Ratio

INDUSTRY, LABOR & HUMAN RELATIONS 7
Appendix

A 4.02 (3) The following diagram illustrates the international symbol for smoking allowed.

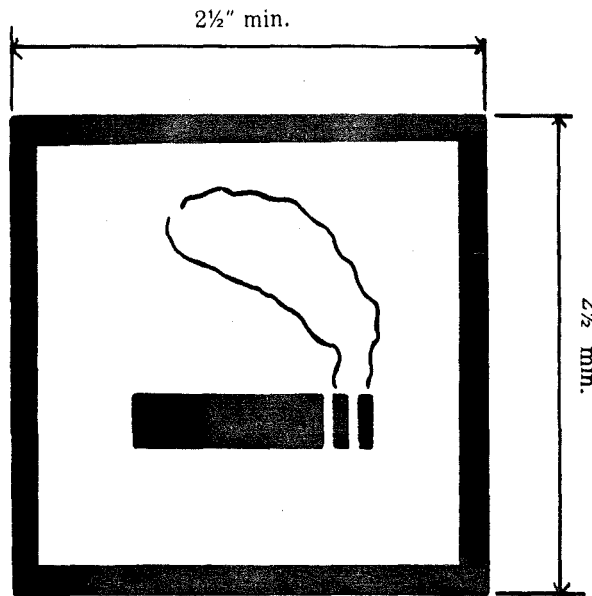

A14.115 MATCHES. The following is a reprint of s. 167.07, Stats.:

167.07 Manufacture, storage and distribution of matches. (1) No person, association or corporation shall manufacture, store, offer for sale, sell, or otherwise dispose of or distribute white phosphorus, single-dipped, strike-anywhere matches of the type popularly known as "parlor matches;" nor manufacture, store, sell, offer for sale, or otherwise dispose of or distribute white phosphorus, double-dipped, strike-anywhere matches, or other type of double-dipped matches, unless the bulb or first dip of such match is composed of a so-called safety or inert composition, nonignitable on an abrasive surface; nor manufacture, store, sell or offer for sale, or otherwise dispose of or distribute matches which, when packed in a carton of five hundred approximate capacity and placed in an oven maintained at a constant temperature of two hundred degrees F., will ignite in eight hours; nor manufacture, store, offer for sale, sell or otherwise dispose of or distribute Blazer, or so-called wind matches, whether of the so-called safety or strike-anywhere type.

(2) No person, association or corporation shall offer for sale, sell or otherwise dispose of or distribute any matches, unless the package or container in which such matches are packed bears plainly marked on the outside thereof the name of the manufacturer and the brand or trademark under which such matches are sold, disposed of or distributed; nor shall more than one case of each brand of matches of any type or manufacture be opened at any one time in the retail store where matches are sold or otherwise disposed of; nor shall loose boxes or paper-wrapped packages of matches be kept on shelves or stored in such retail stores at a height exceeding five feet from the floor; all matches, when stored in warehouses, excepting manufacturers' warehouses at place of manufacture, when such warehouses contain automatic sprinkler equipment, must be kept only in properly secured

cases, and not piled to a height exceeding ten feet from the floor; nor be stored within a horizontal distance of ten feet from any boiler, furnace, stove or other like heating apparatus, nor within a horizontal distance of twenty-five feet from any explosive material kept or stored on the same floor; all matches shall be packed in boxes or suitable packages, containing not more than seven hundred matches in any one box or package; provided, however, that when more than three hundred matches are packed in any one box or package, the said matches shall be arranged in two nearly equal portions, the heads of the matches in the two portions shall be placed in opposite directions, and all boxes containing three hundred and fifty or more matches shall have placed over the matches a center holding or protecting strip, made of chipboard, not less than one and one-quarter inches wide; said strip shall be flanged down to hold the matches in position when the box is nested into the shuck or withdrawn from it.

(3) All match boxes or packages shall be packed in strong shipping containers or cases; maximum number of match boxes or packages contained in any one shipping container or case, shall not exceed the following number:

Number of Boxes	Nominal Number of Matches per Box
One-half gross	700
One gross	500
Two gross	400
Three gross	300
Five gross	200
Twelve gross	100
Twenty gross	over fifty and under 100
Twenty-five gross	under 50

(4) No shipping container or case constructed of fiber board, corrugated fiber board, or wood, nailed or wirebound, shall exceed a weight, including its contents, of 75 pounds; and no lock-cornered wooden case containing matches shall have a weight, including its con-

tents, exceeding 85 pounds; nor shall any other article or commodity be packed with matches in any such container or case; and all such containers and cases in which matches are packed shall have plainly marked on the outside of the container or case the words "Strike-Anywhere Matches" or "Strike-on-the-Box Matches".

(5) Any person, association or corporation violating this section shall be fined for the first offense not less than \$5 nor more than \$25, and for each subsequent violation not less than \$25.

A14.117 (1) (d) DILAPIDATED OR VACANT BUILDINGS

The following is a reprint of s. 66.05, Stats.

66.05 RAZING BUILDINGS; EXCAVATIONS. (1) (a) The governing body or the inspector of buildings or other designated officer in every municipality, except in towns situated in a county of less than 15,000 population upon complaint of a majority of the members of the town board the circuit court, may order the owner of premises upon which is located any building or part thereof within such municipality, which in its judgment is so old, dilapidated or has become so out of repair as to be dangerous, unsafe, unsanitary or otherwise unfit for human habitation, occupancy or use, and so that it would be unreasonable to repair the same, to raze and remove such building or part thereof, or if it can be made safe by repairs to repair and make safe and sanitary or to raze and remove at the owner's option; or where there has been a cessation of normal construction of any building or structure for a period of more than 2 years, to raze and remove such building or part thereof. The order shall specify a time in which the owner shall comply therewith and specify repairs, if any. It shall be served on the owner of record or his agent where an agent is in charge of the building and upon the holder of any encumbrance of record in the manner provided for service of a summons in the circuit court. If the owner or a holder of an encumbrance of record cannot be found the order may be served by posting it on the main entrance of the building and by publishing as a class 3 notice, under ch. 985, before the time limited in the order commences to run.

(b) Whenever a municipal governing body, inspector of buildings or designated officer determines that the cost of such repairs would exceed 50 percent of the assessed value of such building divided by the ratio of the assessed value to the recommended value as last published by the state supervisor of assessments for the municipality within which such building is located, such repairs shall be presumed unreasonable and it shall be presumed for the purposes of this section that such building is a public nuisance.

(c) Acts of municipal authorities under this section shall not increase the liability of an insurer.

(2) (a) If the owner fails or refuses to comply within the time prescribed, the inspector of buildings or other designated officer shall cause such building or part thereof to be razed and removed either through any available public agency or by contract or arrangement with private persons, or closed if unfit for human habitation, occupancy or use. The cost of such razing and removal or closing shall be charged against the real estate upon which such building is located and shall be in lien upon such real estate, and shall be assessed and collected as a special tax. When any building has been ordered razed and removed the governing body or other designated officer under said contract or arrangement aforesaid may sell the salvage and valuable materials at the highest price obtainable. The net proceeds of such sale, after deducting the expenses of such razing and removal, shall be promptly remitted to the circuit court with a report of such sale or transaction, including the items of expense and the amounts deducted, for the use of the person who may be entitled thereto, subject to the order of the court.

If there remains no surplus to be turned over to the court, the report shall so state. If the building or part thereof is unsanitary and unfit for human habitation, occupancy or use, and is not in danger of structural collapse the building inspector shall post a placard on the premises containing the following words: "This Building Cannot Be Used for Human Habitation, Occupancy or Use". And it is the duty of the building inspector or other designated officer to prohibit the use of the building for human habitation, occupancy or use until the necessary repairs have been made.

(b) Any municipality, inspector of buildings or designated officer may, in his official capacity, commence and prosecute an action in circuit court for an order of the court requiring the owner to comply with an order to raze or remove any building or part thereof issued under this section if the owner fails or refuses to do so within the time prescribed in such order, or for an order of the court requiring any person occupying a building whose occupancy has been prohibited under this section to vacate the premises, or any combination of such court orders. Hearing on such actions shall be given precedence over other matters on the court's calendar. Costs shall be in the discretion of the court.

(c) Any person who rents, leases or occupies a building which has been condemned for human habitation, occupancy or use shall be fined not less than \$5 nor more than \$50 or imprisoned not more than 30 days for each week of such violation, or both.

(3) Anyone affected by any such order shall within the time provided by s. 893.76 apply to the circuit court for an order restraining the inspector of buildings or other designated officer from razing and removing the building or part thereof or forever be barred. Hearing shall be had within 20 days and shall be given precedence over other matters on the court's calendar. The court shall determine whether the order of the inspector of buildings is reasonable, and if found reasonable the court shall dissolve the restraining order, and if found not reasonable the court shall continue the restraining order or modify it as the circumstances require. Costs shall be in the discretion of the court. If the court finds that the order of the inspector of buildings is unreasonable, the inspector of buildings or other designated officer shall issue no other order pursuant to the authority of this section in regard to the same building or part thereof until its condition is substantially changed. The remedies provided in this subsection are exclusive remedies and anyone affected by such an order of the inspector shall not be entitled to recover any damages for the razing and removal of any such building.

(4) "Building" as used in this section includes any building or structure.

(5) If any building ordered razed or made safe and sanitary by repairs contains personal property or fixtures which will reasonably interfere with the razing or repair of such building or if the razing of the building makes necessary the removal, sale or destruction of such personal property or fixtures the inspector of buildings or other designated officer may order in writing the removal of such personal property or fixtures by a certain date. Such order shall be served as provided in sub. (1). If the personal property or fixtures or both are not removed by the time specified the inspector may store the same, or may sell it, or if it has no appreciable value he may destroy the same. In case the property is stored the amount paid for storage shall be a lien against such property and against the real estate and shall be assessed and collected as a special tax against the real estate if the real estate is owned by the owner of the personal property and fixtures. If the property is stored the owner thereof, if known, shall be notified of the place of its storage and if it be not claimed by the owner it may be sold at the expiration of 6 months after it has been stored. In case of sale the handling of the sale and the distribution of the net proceeds after deducting the cost of storage and any other costs shall be handled as specified in sub. (2) and a report made to the circuit court as therein specified. Anyone affected by any order made under this subsection may appeal as provided in sub. (3).

(5m) This section shall not limit powers otherwise granted to municipalities by other laws of this state.

(6) In any town, city or village in any county having a population of 500,000 or more no excavation for building purposes, whether or not completed, shall be left open for more than 6 months without proceeding with the erection of a building thereon. In the event any such excavation remains open for more than 6 months, the inspector of buildings or other designated officer in such town, village or city shall order that the erection of a building on the excavation begin forthwith or in the alternative that the excavation be filled to grade. The order shall be served upon the owner of the land or his agent and upon the holder of any encumbrance of record as provided in sub. (1). If the owner of the land fails to comply with the order within 15 days after service thereof upon him, the inspector of buildings or other designated officer shall cause the excavation to be filled to grade and the cost shall be charged against the real estate as provided in sub. (2). Subsection (3) shall also apply to orders issued under this subsection. This shall not be construed to impair the authority of any city or village to enact ordinances in this field.

(7) The action provided in sub. (1) for razing or removing a building on premises in a town situated in a county of less than 15,000 population shall be commenced in accordance with s. 801.02. The authenticated copy of the summons and the complaint shall be served upon the owner and occupant of and any holder of an encumbrance of record against the premises. Procedure shall be the same in all respects as the procedure in other civil actions so far as applicable. Subsection (3) shall not apply to such actions except the court may, upon a showing of hardship or other good cause, restrain for reasonable periods of time the razing or removal of a building or part thereof and the removal, sale or destruction of any personal property or fixtures therein. Costs shall be in the discretion of the court except as to persons found by the court to be acting maliciously in or about the commencement or prosecution of such action.

(8) (a) Whenever an owner of any building, dwelling or structure in any city or village permits the same, either as a result of vandalism or for any other reason, to deteriorate or become dilapidated or blighted to the extent where windows, doors or other openings or plumbing or heating fixtures or facilities or appurtenances of such building, dwelling or structure are either damaged, destroyed or removed so that such building, dwelling or structure offends the aesthetic character of the immediate neighborhood or produces blight or deterioration by reason of such condition, the building inspector or other designated officer of such city or village shall issue a written notice respecting the existence of such defect; such written notice shall be served on the owner of such building, dwelling or structure as set forth in sub. (1) (a) and shall direct the owner of such building, dwelling or structure to promptly remedy the defect within 30 days following the service of such notice.

(b) If such owner fails to remedy or improve the defect in accordance with the written notice furnished by the building inspector or other designated officer as set forth in par. (a), then after the expiration of the 30-day period specified in the written notice such building inspector or other designated officer shall apply to the circuit court of the county in which such building, dwelling or structure constitutes a public nuisance. As a part of the application for such order from the circuit court such building inspector or other designated officer shall file a verified petition in which shall be recited the giving of such written notice, the defect or defects in such building, dwelling or structure, the owner's failure to comply with the notice and such other pertinent facts as may be related thereto. A copy of the petition shall be served upon the owner as provided in sub. (1) (a) and the owner shall have 20 days following service upon him in which to reply to such petition. Upon application by the building inspector or other designated officer the circuit court shall promptly set the petition for hearing. Testimony shall be taken by the circuit court with respect to the allegations of the petition and denials contained in the verified answer. If the circuit court after hearing the evidence with respect to the petition and the answer shall determine that the building, dwelling or structure constitutes a public nuisance, the court shall promptly issue an order directing the owner of such building, dwelling or structure to remedy the defect and to make such repairs and alterations as may be required. The court shall further set a reasonable period of time in which such defect shall be remedied and the repairs or alterations completed. A copy of such order shall be served upon the owner as provided in sub. (1) (a). The order of the circuit court shall state in the alternative that if the order of the court is not complied with within the time fixed by the court, then such building inspector or other designated officer may proceed to raze the building, dwelling or structure. All costs or disbursements with respect to such razing shall be as provided for in sub. (2) (a).

(c) Either the owner or the city or village may appeal to the court of appeals within 30 days from the date of entry of the order of the circuit court.

(d) Any building, which under par. (a) either as a result of vandalism or for any other reason is permitted to deteriorate or become dilapidated or blighted to the extent where windows, doors or other openings or plumbing or heating fixtures or facilities or appurtenances of such building, dwelling or structure are either damaged, destroyed or removed so that such building, dwelling or structure offends the aesthetic character of the immediate neighborhood and produces blight or deterioration by reason of such condition, is a public nuisance.

A14.119 CHIMNEYS AND HEATING APPLIANCES. The following is a reprint of
ss. ILHR 64.45 to 64.50:

Part VI—Chimneys, Gas Vents, Mechanical Draft and Venting Devices

ILHR 64.45 Chimneys, smoke stacks, gas vents, mechanical draft and venting devices. (1) GENERAL REQUIREMENTS. Heating equipment using solid, liquid or gas fuels shall be vented to the outside, except as permitted in s. ILHR 64.21. A natural draft chimney or other venting device shall have the height and area to remove the products of combustion. Chimneys, smoke stacks, gas vents, mechanical draft and venting devices shall comply with the requirements of NFPA No. 211 [s. ILHR 51.27 (7a)], Chimneys, Fireplaces and Vents. **FP**

(2) **NONCOMBUSTIBLE SUPPORTS.** All chimneys or gas vents shall be supported from noncombustible construction unless otherwise approved.

(3) **TERMINATION.** (a) *Gravity type.* 1. All chimneys or smokestacks depending on a gravity principle for the removal of the products of combustion shall extend at least 3 feet above the highest point where the chimneys or smokestacks pass through the roof of the building, and at least 2 feet higher than any ridge, peak or wall within 10 feet of the chimney or smokestack.

2. Type "B", "BW" and "L" vents and single wall vent pipes depending on a gravity principle for the removal of the products of combustion shall extend at least 2 feet above the highest point where the vents or pipes pass through the roof of the building, and at least 2 feet higher than any ridge, peak or wall within 10 feet of the vent or pipe.

(b) *Mechanical type.* The height and cross-sectional area may be reduced for chimneys employing a mechanical draft system of either forced or induced draft when approved by the department.

History: Cr. Register, December, 1975, No. 240, eff. 1-1-76; am. (1) and (3)(a), Register, January, 1980, No. 289, eff. 2-1-80.

ILHR 64.46 Masonry chimneys. The design and construction of the chimney shall conform to the provisions of this section. **FP**

Register, August, 1985, No. 356

64.46

380

WISCONSIN ADMINISTRATIVE CODE

ILHR 64

Heating, Ventilating and Air Conditioning

(1) **MATERIALS.** The walls shall be built of brick or other approved fire-resistant material. No chimney shall rest upon a flooring of wood nor shall any wood be built into or in contact with any chimney. Combustible headers, beams, joists and studs shall be located at least 2 inches from the outside face of a chimney. The foundation shall be designed and built in conformity with the requirements for foundations for buildings. In no case shall a chimney be corbeled out more than 6 inches from the wall and in every case the corbeling shall consist of at least 5 courses of brick.

(2) **FLUE SIZE.** Every masonry chimney shall have walls at least 8 inches in solid thickness, except that in a chimney with a flue not larger than 260 square inches where a fire clay or other suitable refractory clay flue lining is used for the full height of the chimney the walls shall not be less than 4 inches in solid thickness. No smoke flue shall have a cross-sectional area less than 64 square inches. Flue linings 7 inches by 7 inches inside, or 8 inches in diameter inside, may be used.

(3) **FLUE LININGS.** All flue linings shall be capable of withstanding reasonably high temperatures and flue gases and shall have a softening point not lower than 1800° F. Flue linings shall be not less than 3/8 inch in thickness and shall be built in as outer walls of the chimney are constructed. Flue linings shall start from a point not less than 8 inches below the bottom of the smoke pipe intake and shall be continuous to a point not less than 4 inches above the enclosing walls.

(4) **SMOKE PIPE CONNECTION.** If there is more than one smoke pipe connected to a flue, the connections shall be at different levels. Two or more heating units, or appliances, may be connected to a common smoke pipe, or breeching, if joined by Y fittings as close as practicable to the flue. In all such cases, the size of the breeching and the flue shall be sufficient to accommodate the total volume of flue gases.

(5) **CLEAN-OUT OPENING.** Every chimney shall be provided with a clean-out opening at the base. Such openings shall be equipped with metal doors and frames arranged to remain closed when not in use.

(6) **WIND PRESSURE.** Every chimney shall be designed to withstand wind pressures in accordance with the requirements of s. ILHR 53.12.

History: Cr. Register, December, 1975, No. 240, eff. 1-1-76; am. (1), Register, January, 1980, No. 289, eff. 2-1-80.

FP ILHR 64.47 Metal smokestacks. (1) **SMOKESTACKS IN EXCESS OF 30 FEET.** The thickness of the metal walls shall be at least 3/16 inch for smokestack heights up to 40 feet and 1/4 inch for greater heights. Stacks used for manufacturing, high-pressure boilers, furnaces or other similar heating or manufacturing appliances shall be lined with firebrick, or equivalent, for a distance of not less than 25 feet from the place where the smoke pipe enters and shall be protected on the outside up to and through the roof of the building with 8 inches of masonry, or a metal shield which provides an 8-inch ventilated air space between such shield and the stack. All stacks shall be properly guyed if the height of the stack exceeds 15 times its least diameter.

(a) *Exception.* Public utility or industrial power plants are exempted from the protection requirements of this paragraph if they are of type 1 or 2 construction.

Register, August, 1985, No. 356

DEPT. OF INDUSTRY, LABOR & HUMAN RELATIONS 381
Heating, Ventilating and Air Conditioning ILHR 64

(2) **SMOKESTACKS LESS THAN 30 FEET.** Smokestacks less than 30 feet high may be constructed of not less than No. 10 U.S. gauge steel, with either welded or riveted joints, and may be mounted directly upon masonry chimneys or foundations or upon industrial heating or power boilers provided all of which are designed to support the stack load. A clearance of not less than 6 inches shall be maintained at all times around such smokestack and any combustible material within 12 inches of such smokestack shall be protected by ¼ inch of asbestos covered by sheet metal.

History: Cr. Register, December, 1975, No. 240, eff. 1-1-76; am. (1) (intro.), Register, December, 1978, No. 276, eff. 1-1-79.

ILHR 64.48 Factory-built chimneys and gas vents. (1) GENERAL. Factory-built chimneys and gas vents shall be of an approved type. **FP**

(2) **TYPES OF APPROVED CHIMNEYS AND GAS VENTS.** (a) *Residential type and building heating appliance.* An approved "residential type and building heating appliance" chimney or "building heating appliance" chimney may be used with solid-, liquid- or gas-fired heating appliances where the flue gas temperature does not exceed 1000° F. continuously, and does not exceed 1400° F. for infrequent brief periods of forced firing.

(b) *Type "B".* An approved type "B" gas vent may be used with gas-fired appliances where the flue gas temperature does not exceed 550° F. at the outlet of the draft hood.

(c) *Type "BW".* An approved type "BW" gas vent may be used with a vented recessed wall heater.

(d) *Single wall vent pipe.* An approved single wall vent pipe may be used with gas-fired, low-heat appliances (low-pressure boilers, furnaces and space heaters). The vent shall be not less than No. 20 standard gauge galvanized iron, No. 24 Brown and Sharpe gauge sheet copper, or other approved corrosion-resistant material. The installation shall conform to the requirements of s. ILHR 64.50.

(e) *Type "L".* An approved type "L" vent may be used with oil-fired appliances listed as suitable by a recognized agency and with gas-fired appliances approved for type "B" vents.

(f) *Equipment listed with venting system.* Venting systems included with the listing of the heating appliance may be used subject to the requirements and limitations of the listing.

Note: The department recognizes, as approved, chimneys designated as "residential type", "building heating appliance", "B", "BW" and "L" types listed by Underwriters' Laboratories, Inc.

History: Cr. Register, December, 1975, No. 240, eff. 1-1-76; r. and recr., Register, December, 1978, No. 276, eff. 1-1-79; am. (2)(a) and (d), Register, December, 1981, No. 312, eff. 1-1-82; cr. (2) (f), Register, December, 1983, No. 336, eff. 1-1-84.

ILHR 64.49 Gas vents. All gas ranges (except those designed as unvented), water heaters and other gas-fired equipment shall be provided with vent pipes conforming to the requirements for gas vents as specified in s. ILHR 64.48 and for connectors as specified in s. ILHR 64.50. Commercial kitchen appliances including but not limited to ranges, ovens, **FP**

Register, August, 1985, No. 356

booster heaters and similar equipment may be vented into the kitchen hood exhaust system.

History: Cr. Register, December, 1975, No. 240, eff. 1-1-76; am. Register, December, 1978, No. 276, eff. 1-1-79; am. Register, January, 1980, No. 289, eff. 2-1-80; renum. from ILHR 64.50 and am., Register, December, 1981, No. 312, eff. 1-1-82.

FP ILHR 64.50 Chimney and vent connectors (1) CONSTRUCTION AND INSTALLATION. The construction and installation of chimney connectors shall conform with the following requirements:

(a) *Concealed space.* No chimney connector shall pass through any outside window, door or combustible outside wall, nor be concealed in any closet, attic or similar space;

(b) *Combustible partitions and walls.* Connectors for appliances shall not pass through interior walls or partitions constructed of combustible material unless they are guarded at the point of passage by:

1. Metal ventilated thimbles not less than 12 inches larger in diameter than the connector, or

2. Metal or burned fireclay thimbles built in brickwork or other approved fireproofing materials extending not less than 8 inches beyond all sides of the thimble;

(c) *Distance from materials.* Connectors shall be installed with clearance to combustibles specified in par. (b) or NFPA Standard 211;

(d) *Multiple appliance venting.* Two or more appliances using the same type of fuel may be connected to a common gravity-type chimney or vent, provided the appliances are equipped with primary safety controls and listed shutoff devices and comply with the following requirements:

1. The appliances shall be located in the same story, except for engineered venting systems,

2. The appliances shall be joined at a manifold or Y-type fitting as close to the chimney or vent as possible, unless the connector from each appliance enters a separate chimney or vent inlet and the inlets are offset at least 12 inches vertically or are at right angles to each other,

3. The connector and chimney or vent shall be sized to accommodate the total volume of flue gases. For gas-burning appliances, the venting area shall be at least equal to the size of the largest vent connector plus at least 50% of the area of the other vent connectors, or

4. A chimney serving a fireplace or other piece of solid-fuel equipment shall not be used to vent any other appliance;

(e) *Pitch and length.* Chimney or vent connectors shall have no more than two 45° offsets with the vertical. The horizontal length shall not exceed 75% of the total vertical height of the total venting system measured from the appliance outlet. Chimney or vent connectors shall be pitched up at least ¼ inch per foot from the appliance outlet collar to the chimney or vent inlet;

(f) *Dampers.* A manual cast iron or equivalent damper to control the draft shall be provided in the chimney connector next to solid-fuel fired equipment. Manually operated dampers shall be prohibited in chimney or vent connectors of all other appliances. When used, listed automati-

64.51

DEPT. OF INDUSTRY, LABOR & HUMAN RELATIONS 383
Heating, Ventilating and Air Conditioning ILHR 64

cally operated dampers interlocked with the heating appliance shall be installed in accordance with the approved listing; and

(g) *Materials and thickness.* 1. Except as specified in subd. 2., chimney or vent connectors shall be listed or conform to the type of material and thickness indicated in Table 64.50 or equivalent.

2. 'Exception'. Connectors serving listed residential-type gas appliances shall be not less than .016 inch galvanized steel.

TABLE 64.50

MINIMUM CHIMNEY CONNECTOR METAL THICKNESS

Galvanized Steel		
Diameter of Connector	Min. thickness (inch)	Gauge
Less than 6 inches	.019	26
6 inches to less than 10 inches	.024	24
10 inches to 13 inches	.030	22
14 inches to 16 inches	.036	20
Greater than 16 inches	.058	16

History: Cr. Register, December, 1981, No. 312, eff. 1-1-82; am. (1) (c) and (g) 2., Register, August, 1985, No. 356, eff. 1-1-86.

A14.118 (3) FOOD PREPARATION EQUIPMENT. The following is a reprint of
s. ILHR 64.67 (6):

FP (6) AUTOMATIC SUPPRESSION SYSTEMS. Exhaust hoods and ducts in kitchens used for commercial purposes shall be protected by an approved automatic fire suppression system. The suppression system shall comply with the following:

(a) When the fire suppression system is activated, all gas and electrical sources serving cooking appliances, grease consuming appliances or fume incinerators and equipment associated with the hoods shall be automatically deactivated. Such gas and electrical sources shall not be capable of reactivation except by manual means after the fire suppression system has been serviced and is again ready for action;

(b) 1. Except as provided in subd. 2., hood and duct suppression systems shall provide for both automatic and manual actuation of the system;

2. Automatic fire sprinkler systems using water need not be provided with means for manual actuation.

(c) A manual station for actuation of the suppression system shall be located at or near one of the means of egress from the area but not nearer than 10 feet to the range hood unless otherwise specifically approved, and shall be securely mounted not less than 4½ feet nor more than 5 feet above the floor;

(d) The system shall be maintained at full operating capacity by the owner and shall be serviced every 6 months; and

(e) All nozzles shall be accessible for cleaning and replacement.

A14.121 INTERIOR FINISHES AND FLAMMABLE AND DECORATIVE MATERIALS. The following is a reprint of s. ILHR 51.07:

ILHR 51.07 Interior finishes. (1) **SCOPE.** The requirements of this section apply to the interior finishes or surfaces of a building.

Note #1: See s. ILHR 51.06 for the restrictions of foam plastics.

Note #2: Toxicity of the products of combustion is *not* included as a basis in determining the smoke developed criteria of this section. The smoke developed criteria is based solely upon the obscuration of light.

(2) **APPLICATION TO MATERIALS.** (a) Except as provided in par. (b), the classification of interior finish materials as specified in this section shall include the basic material used by itself or in combination with other materials.

(b) Subsequently applied paint or wall covering not exceeding 1/28 inch in thickness and classified 450 or less on the smoke test scale are exempt from the provisions of par. (a).

(3) **TRIM AND INCIDENTAL FINISH.** (a) Interior finish not in excess of 10% of the aggregate wall and ceiling areas of any room or space may be Class C materials in occupancies where interior finish of Class A or Class B is required.

(b) In addition to the other requirements of this section, foam plastic used as interior trim and incidental finish shall also comply with the following:

1. The minimum density is 20 pounds per cubic foot;
2. The maximum thickness of the trim is 1/2 inch and the maximum width is 4 inches;
3. The trim constitutes no more than 10% of the area of any wall or ceiling; and
4. The flame-spread rating does not exceed 75 when tested in accordance with ASTM E-84 and the smoke developed rating is not limited.

(4) **EXPOSED CONSTRUCTION.** (a) This section does not require the installation of interior finish, but where construction or fire protection materials are exposed in rooms or spaces used for the occupancies specified, the hazard from rate of flame spread of the exposed materials shall be not greater than that of the interior finish permitted for such occupancy or use.

(b) Exposed portions of structural members of Type No. 4-Heavy Timber Construction shall not be subject to the interior finish requirements of this section.

(5) **USE OF INTERIOR FINISHES.** Interior finish material shall be used in accordance with requirements specified in Table 51.07.

WISCONSIN ADMINISTRATIVE CODE

ILHR 51

Definitions and standards

TABLE 51.07

MINIMUM INTERIOR FINISH REQUIREMENTS

Occupancy	Required Exit Enclosures ¹		Exit Access ^{1,2}		Rooms or Enclosed Spaces ^{1,2}	
	Walls & Ceilings ⁴	Floor ⁵	Walls & Ceilings ⁴	Floor ⁵	Walls & Ceilings ⁴	Floor ^{3,5}
Ch. ILHR 54 Occupancies Other than Storage and Warehouses	A	II	A or B	II	A, B or C	DOC FF-1 ⁶
Ch. ILHR 54 Storage and Warehouse Occupancies	A or B	DOC FF-1 ⁶	A or B	DOC FF-1 ⁶	A, B or C	DOC FF-1 ⁶
Ch. ILHR 55 Places of Assembly	A	I	A	II	A or B ⁷	DOC FF-1 ⁶
Ch. ILHR 56 Places of Instruction	A	I	A or B	II	A, B or C	DOC FF-1 ⁶
Ch. ILHR 57 Residential Occupancies	A	II	A or B	II	A, B or C	DOC FF-1 ⁶
Ch. ILHR 58 Health Care and Places of Detention	SEE CHAPTER ILHR 58 FOR SPECIFIC REQUIREMENTS					
Ch. ILHR 59 Hazardous Occupancies	A	DOC FF-1 ⁶	A or B	DOC FF-1 ⁶	A, B or C	DOC FF-1 ⁶
Ch. ILHR 60 Day Care Centers (20 Children or Less)	A or B	DOC FF-1 ⁶	A or B	DOC FF-1 ⁶	A, B or C	DOC FF-1 ⁶
Ch. ILHR 60 Day Care Centers (More than 20 Children)	A	II	A or B	II	A, B or C	DOC FF-1 ⁶
Ch. ILHR 62 Specialty Occupancies	A, B or C	DOC FF-1 ⁶	A, B or C	DOC FF-1 ⁶	A, B or C	DOC FF-1 ⁶

DEPT. OF INDUSTRY, LABOR & HUMAN RELATIONS 71
Definitions and standards ILHR 51

Notes to Table 51.07

¹ Exposed portions of structural members of Type No. 4-Heavy Timber Construction are not subject to the requirements of this table.

² Where a complete automatic sprinkler system is installed, materials with an interior finish of Class B or C may be used in places where Class A or B materials, respectively, are required and floor finish materials with an interior finish of Class II or materials complying with the DOC FF-1-70 "pill test" may be used in places where Class I or II materials, respectively, are required.

³ Requirements for rooms or enclosed spaces are based upon the spaces being separated from exit access corridors and exits by partitions extending from the floor to the ceiling. Where the room or enclosed space is not separated from the exit access corridor, the room or space is considered part of the exit access or the exit.

⁴ Materials having napped, tufted, looped or similar surfaces, such as carpet, when applied on walls or ceilings shall meet the requirements for Class A interior finish.

⁵ Wood, vinyl, linoleum, terrazzo, resilient and other approved finished floors or floor covering materials are exempt from the provisions of this table.

⁶ All carpet manufactured for sale in the U.S. is required by federal regulations to comply with the DOC FF-1-70 "pill test" (16 CFR Para 1630). If a material other than carpet is used, the material should be shown to be resistant to flame propagation as a material which passes the DOC FF-1-70 test (minimum critical radiant flux of 0.04 watts/cm²).

⁷ Class C interior finish materials may be used in places of assembly with a capacity of 400 persons or less.

(6) APPLICATION OF INTERIOR FINISH. (a) *Attachment*. Interior finish materials shall be applied or otherwise fastened in such a manner that they will not readily become detached when subjected to room temperature of 200° F. or less for 30 minutes, or otherwise become loose through changes in the setting medium from the effects of time or conditions or occupancy.

(b) *Application to structural elements*. 1. Interior finish materials applied to walls, ceilings or structural elements of a building or structure which are required to be of fire-resistive rated or noncombustible construction shall be applied directly against the exposed surface of such structural elements or to furring strips attached to such surfaces.

2. Where furring strips are used, all concealed spaces shall be firestopped into areas not greater than 10 square feet in area or 8 feet in any dimension.

(c) *Furred construction*. Where walls, ceilings or other structural elements are required to be of fire-resistive rated or noncombustible construction, and the interior finish is set out or dropped distances greater than 1¼ inches from the surface of the elements, only material of which both faces qualify as Class A shall be used, unless the finish material is protected on both sides by an approved automatic fire suppression system or is attached to a noncombustible backing as specified in par. (e) or to furring strips applied directly to such backing as specified in par. (b).

(d) *Class B and C finish materials*. Interior finish materials, other than Class A materials, which are less than ¼ inch in thickness shall be applied directly against a noncombustible backing or a backing of fire-retardant treated wood unless the tests under which the material has been classified were made with the materials suspended from the noncombustible backing.

(e) *Backing material*. 1. Backing for interior finish materials shall be a continuous surface with permanently tight joints, equal in area to the

51.07

72 WISCONSIN ADMINISTRATIVE CODE
ILHR 51 Definitions and standards

area of the finish, and extending completely behind such finish in all directions.

2. Backing shall be of noncombustible or fire retardant treated wood materials.

3. When the backing does not constitute an integral part of the structural elements or system, it shall be attached directly to the structural elements or to furring strips as specified in par. (b) or may be suspended from the structural members at any distance provided concealed spaces are firestopped as specified in s. ILHR 53.63 (1).

Note: See s. ILHR 51.01 (75a) for further explanatory information.
Class A Interior Finish — flame spread 0-25, smoke developed 0-450.
Class B Interior Finish — flame spread 26-75, smoke developed 0-450.
Class C Interior Finish — flame spread 76-200, smoke developed 0-450.
Class I Interior Floor Finish — critical radiant flux — .45 watts/cm².
Class II Interior Floor Finish — critical radiant flux — .22 watts/cm².

History: Cr. Register, December, 1981, No. 312, eff. 1-1-82; am. table, Register, October, 1982, No. 322, eff. 11-1-82; renum. (3) to be (3) (a), cr. (3) (b) and (6), Register, December, 1983, No. 336, eff. 1-1-84; am. (6) (d) (intro.), Register, August, 1985, No. 356, eff. 1-1-86.

A14.122 FIRE RESISTIVE CONSTRUCTION AND COMPONENTS. The following is a reprint of ss. ILHR 51.047 and 51.048.

ILHR 51.047 Fire-rated door assemblies in fire-rated construction. (1) FP
FIRE-RATED DOOR ASSEMBLIES. Door openings, where permitted in fire-rated walls, shall be protected with fire-rated door assemblies as specified in Table 51.047. Fire-rated door assemblies shall be tested in accordance with ASTM E-152.

TABLE 51.047

Fire-resistive Rating of Wall (in hours)	Minimum Fire-resistive Rating of Required Fire Door Assembly (in hours)
4-hour	3-hour
3-hour	3-hour
2-hour	1½-hour
1-hour	¾-hour
¾-hour	¾-hour
see occupancy chs. ILHR 54-62	½-hour (20 min.)

(a) *Exception.* Doors leading to fire escapes, except doors leading to Class A fire escapes in apartments and row houses, shall be at least ¾-hour fire-rated door assemblies.

(b) Where the occupancy chapters of this code permit, 20-minute fire-rated door assemblies, or equivalent, may be provided, without a closing device.

(2) LABELS. Fire-rated door assemblies shall be labeled with a permanent label, securely attached and located to permit visual inspection after installation. The label shall identify the time rating, testing laboratory, listing agency and manufacturer.

(a) Labeled fire-door assemblies shall not be modified without written acceptance from the testing laboratory.

(3) INSTALLATION OF FIRE-RATED DOORS. The fire-rated door assemblies shall be installed with frame, hinges, latches, closing devices and counterweights in accordance with methods and standards approved by the department. Adequate clearance shall be maintained to permit free operation of fire-rated doors.

Note 1: The department will accept recommended practices for installation covered in "Standard for Fire Doors and Windows," NFPA No. 80.

Note 2: See s. ILHR 51.15 for exit door requirements.

(4) SECURING DOOR FRAMES. Methods of securing door frames to adjacent construction shall be illustrated on the plans submitted to the department for review.

(5) DOOR CLEARANCES. The maximum swinging-door clearances to frame shall be $\frac{1}{8}$ inch on sides and top and $\frac{3}{4}$ inch at bottom between sill or floor.

FP (6) DOOR CLOSING DEVICES. All labeled fire-rated doors, where required, shall be equipped with an approved automatic or self-closing device as defined in s. ILHR 51.01 (17).

(a) All doors serving smokeproof towers or interior enclosed stairways shall be equipped with a self-closing device or an automatic closing device actuated by products of combustion other than heat.

(b) The requirements of sub. (6) (a) shall also be retroactive to existing buildings.

(c) Doors provided with a self-closing device shall remain in a closed position.

Note: The intent of this rule is to accept normal usage of the door, but not permit doors with this closing device to be blocked open at any time.

(d) Where a pilot weight is used, it shall be suspended from a chain or wire cable, and shall be installed in a protective housing.

Note: For specific types of closing devices permitted, please refer to the sections dealing with classes of construction and/or the occupancy chapters.

History: Cr. Register, February, 1971, No. 182, eff. 7-1-71; r. eff. 8-1-71 and recr. eff. 1-1-72, Register, July, 1971, No. 187; am. (1) (intro.), r. and recr. (1) (a) 1., Register, September, 1973, No. 213, eff. 10-1-73; cr. (1) (a) 1. e., Register, December, 1974, No. 228, eff. 1-1-75; r. and recr., Register, December, 1975, No. 240, eff. 1-1-76; r. and recr. (6), Register, December, 1976, No. 252, eff. 1-1-77; cr. (2) (a), Register, January, 1980, No. 289, eff. 2-1-80; am. (1), Register, December, 1981, No. 312, eff. 1-1-82; am. (6) (a), Register, December, 1983, No. 336, eff. 1-1-84.

ILHR 51.048 Fire window and glass block assemblies in fire-rated construction. (1) WINDOW OPENINGS. Window openings, where permitted in Register, August, 1985, No. 356

fire-rated walls, shall be protected with fire window or glass block assemblies rated as ¾-hour by an approved laboratory and tested in accordance with ASTM E-163 standard method [ILHR 51.25 (53)].

(2) **SIZE.** (a) *Fire window assemblies.* The size of the wired glass and frame assembly shall not exceed the size tested. Windows combined in multiple assemblies shall be separated by approved nonbearing metal mullions.

Note: Fire windows have been classified for either moderate or light fire exposure. For moderate fire exposure, the individual glass size is limited to 720 square inches. (Size limitation either 48 inches maximum width or 54 inches maximum height.) For light fire exposure, the individual glass size is limited to 1,296 square inches. (Size limitations either 54 inches maximum width or 54 inches maximum height.) Please refer to sections for classes of construction and/or occupancy chapters for fire window classifications.

(b) *Glass block assemblies.* Openings for glass block assemblies shall not exceed 120 square feet in area. The width or height of the opening shall not exceed 12 feet.

Note: Openings for glass block assemblies are classified for light fire exposure.

(3) **MATERIALS AND INSTALLATION.** (a) *Frames.* Approved metal frames shall be securely fastened to the construction and be capable of resisting all wind stresses and other stresses to which they are likely to be subjected.

(b) *Wired glass.* The wired glass shall be labeled wired glass, ¼-inch thick, and shall be well bedded in approved glazing compound. All exposed joints between the metal shall be struck and pointed. The clearance between the edges of the glass and metal framing shall not exceed ⅛ inch.

(c) *Glass block.* Glass block assemblies shall be installed according to the details of the tested assembly.

Note: The department will accept recommended practices for installation covered in "Standard for Fire Doors and Windows," NFPA No. 80.

(4) **LABELS.** Fire window assemblies shall be labeled with a permanent label, securely attached and located to permit visual inspection after installation. The label shall identify the time rating, testing laboratory, listing agency and manufacturer. Glass block shall be listed by an approved laboratory.

History: Cr. Register, December, 1975, No. 240, eff. 1-1-76.

There are no pages 76 and 77.

A14.123 FIRE PREVENTION, DETECTION AND PROTECTION SYSTEMS REQUIREMENTS.
The following is a reprint of ss. 51.21 to 51.245 of the Wisconsin Building
and Heating, Ventilating and Air Conditioning Code.

ILHR 51.21 Standpipe and hose systems. (1) GENERAL REQUIREMENTS. All required standpipe and hose systems shall meet the requirements of this section.

Note: The department will accept installations conforming to the latest edition of NFPA No. 14—Standard for Installation of Standpipe and Hose Systems.

(2) **CLASSES OF SERVICE.** (a) *Class I - Fire department standpipes.* For use by fire departments and those trained in handling heavy fire streams from a 2½-inch hose.

(b) *Class II - First-aid standpipes.* For use primarily by occupants of a building until the arrival of the fire department (1½-inch hose).

(c) *Class III - Combination fire department and first-aid standpipes.* For use by either fire departments and those trained in handling heavy hose streams or by the building occupants.

(d) *Dry standpipes.* For use by fire departments.

(3) **CLASS I - FIRE DEPARTMENT STANDPIPES.** (a) *Where required.* Fire department standpipes shall be provided for all buildings exceeding 60 feet in height.

1. Required standpipes shall be installed as construction progresses, to make them available for fire department use in the topmost floor constructed. Temporary standpipes may be provided in place of permanent standpipes during the period of construction when approved by the local fire department.

88

WISCONSIN ADMINISTRATIVE CODE

ILHR 51

Definitions and standards

(b) *Number of standpipes.* Standpipes shall be sufficient in number so that any part of every floor area can be reached within 30 feet by a nozzle attached to 100 feet of hose connected to the standpipe in an unsprinklered building and 150 feet of hose in a sprinklered building.

(c) *Cross connections.* When 2 or more standpipes are required, they shall be cross connected and equipped with individual control valves. All control valves shall be of an approved indicating type valve. The valves shall be located so that the water supply to any standpipe riser can be shut off without interrupting the water supply to the remaining standpipes and be readily accessible to the fire department.

(d) *Location of outlets.* Hose outlets shall be located in stairway enclosures. Where stairways are not enclosed, outlets shall be at the inside of outside walls, within one foot of a smokeproof tower, interior stairway or fire escape. In buildings containing large interior areas, standpipes may be located at accessible interior locations.

(e) *Protection of standpipes.* Standpipes shall be protected against mechanical and fire damage. Dry standpipes shall be visible for inspection and not concealed.

Note: It is not the intent of this section to require standpipes to be protected with an hourly rated fire protection.

(f) *Size.* No required standpipe shall be less than 4 inches in diameter, and not less than 6 inches in diameter for standpipes in excess of 100 feet in height unless the building is completely sprinklered and the standpipe system is hydraulically designed in accordance with the requirements of sub. (6).

(g) *Hose valves and connections.* An approved 2½-inch hose-connection valve shall be located at each story, not less than 3 feet nor more than 6 feet above the floor level. Hose-connection valves shall be equipped with a tight-fitting cap on a chain and having lugs for a spanner wrench. When the building is completely sprinklered, and class II service is omitted, each standpipe outlet location shall be equipped with a 2½-inch hose valve, a 2½-inch by 1½-inch reducer, and a cap with an attached chain.

(h) *Hose threads.* All threads on hose connections shall be of national standard dimensions.

Note: Section 213.15, Stats., requires that all hose connections be fitted with the national standard hose threads adopted by the national fire protection association.

(i) *Fire department connection.* An approved fire department connection shall be installed on a 4-inch or larger pipe connection with each standpipe system. The connection shall be marked "Standpipe". If automatic fire sprinklers are also supplied by the hose connection, the sign shall read "Standpipe and Automatic Sprinkler". The elevation of the connection may be not less than 18 inches nor more than 42 inches above the sidewalk or ground. If municipal water is available at the building site, the fire department connection shall be located as close as possible to and within 150 feet of any fire hydrant.

(j) *Automatic water supply.* An automatic water supply for a wet standpipe system shall be designed to provide not less than the following capacity from top outlets at not less than 65 psi flowing pressure for a period of 30 minutes; 500 gpm for a single standpipe; 750 gpm for 2 inter-

INDUSTRY, LABOR & HUMAN RELATIONS 89
Definitions and standards ILHR 51

connected standpipes; 1,000 gpm for larger systems. Any of the following supplies will be acceptable:

1. Public waterworks system where pressure and discharge capacity are adequate;
2. Approved automatic fire pump (or pumps);
3. Pressure tank;
4. Gravity tank;
5. Approved manually controlled fire pump operated by remote control devices at each hose outlet; or
6. Reservoirs.

(k) *Dry standpipes.* If only one standpipe is required, a dry standpipe may be used. A dry standpipe shall be limited to a single riser and shall not exceed 150 feet in height.

(4) CLASS II - FIRST-AID STANDPIPES. (a) *Where required.* First-aid standpipes shall be provided as required by the occupancy chapters of this code.

(b) *Number and location.* Standpipes shall be sufficient in number so that any part of every floor area, including basements, can be reached within 30 feet by a nozzle attached to not more than 100 feet of hose connected to a standpipe.

1. Hose outlets shall be located in occupied areas and preferably in corridors or at interior columns.

(c) *Size.* No required standpipe shall be less than 2 inches in diameter for buildings 4 or less stories or 50 feet in height, and not less than 2½ inches in diameter for buildings exceeding 4 stories or 50 feet in height.

(d) *Hose valves and connections.* An approved 1½-inch hose valve shall be located not more than 5 feet above the floor level. Where the static pressure at any standpipe hose outlet exceeds 100 psi, an approved device shall be installed at the outlet to reduce the pressure with the required flow at the outlet to not more than 100 psi.

(e) *Hoses.* Not more than 100 feet of hose shall be attached to each outlet. Hoses shall be of an approved type, 1½-inches in diameter, with ½-inch solid stream or combination nozzle attached, and shall be located in approved cabinets, racks or reels. In locations where the use of a solid stream may contribute to the spread of fire by scattering the burning material or where the existence of flammable liquids make the use of spray stream desirable, combination nozzles which give a spray or a solid stream shall be provided instead of ½-inch nozzles.

(f) *Water supply.* An automatic water supply shall be provided. The water supply shall be designed for 100 gpm for 30 minutes with 65 psi flowing pressure at the top outlet. The water supply may be from a city connection, gravity tank, pressure tank or pump.

Note #1: The department will permit the domestic water supply to service class II standpipes provided no intervening control valves are installed to interrupt the service of the standpipe and a check valve is installed to prevent contamination of the domestic water supply.

90 WISCONSIN ADMINISTRATIVE CODE
 ILHR 51 Definitions and standards

Note #2: The department will permit pumps, other than fire pumps, provided the water supply meets the requirements of sub. (4) (f).

Note #3: See ch. ILHR 82 for requirements pertaining to cross connections.

(5) **CLASS III — COMBINED FIRE DEPARTMENT AND FIRST-AID STAND-PIPES.** (a) *Where permitted.* The features of class I and II service may be combined in a single system if served by an acceptable automatic water supply conforming to the requirements of sub. (3) (j).

(b) *Requirements.* Class III standpipes shall conform to the requirements of class I service except that 1½-inch outlets with a hose and 2¼-inch outlets shall be provided on each floor and shall be installed to the requirements of the respective classes of service.

(6) **DRY STANDPIPES.** (a) *Where required.* Dry standpipes shall be provided as required by chs. ILHR 54 to 62.

Note: See ss. ILHR 54.15, 55.33, 56.20, 57.15 and 62.30.

(b) *Number and location.* Required dry standpipes shall be provided in each stair enclosure.

(c) *Hose valves and connections.* 1. Required dry standpipes shall be provided with approved 2½ inch valve hose connections at each floor level with one connection in the stair tower and one immediately outside.

2. Required dry standpipes with a fire department siamese connection greater than 50 feet to a street shall be interconnected to a standpipe system with the connection 50 feet or less to a street.

(d) *Miscellaneous requirements.* Dry standpipes shall conform to the requirements specified in sub. (3) (e) to (i).

(7) **COMBINED AUTOMATIC SPRINKLER AND STANDPIPE SYSTEM.** (a) *Definition.* A combined system is a system where the vertical water piping serves both the automatic sprinkler system and the 2¼-inch hose outlets of the standpipes used by the fire department. The combined system shall comply with the automatic sprinkler requirements of s. ILHR 51.23 and the standpipe and hose requirements of s. ILHR 51.21.

(b) *Water supply and riser size.* The minimum water supply and riser size for a combined system shall comply with the requirements of sub. (3) (f) and (j), except the minimum water supply for a combined system for a completely sprinklered, light hazard occupancy building shall be 500 gallons per minute. When the building is completely sprinklered, the risers may be sized by hydraulic calculations.

Note: NFPA No. 13—Standard for Installation of Sprinkler Systems, defines light hazard occupancy as occupancies where the quantity and/or combustibility is low and fires with relatively low rates of heat release are expected, such as: churches; clubs; educational; hospitals; institutional; libraries, except large stack rooms; museums; nursing or convalescent homes; offices, including data processing; residential; restaurant seating areas; theaters and auditoriums, excluding stages and prosceniums.

(c) *Connections.* Each connection from a vertical riser of a combined system shall be provided with an individual control valve of the same size as the outlet.

INDUSTRY, LABOR & HUMAN RELATIONS 91
Definitions and standards ILHR 51

(8) MAINTENANCE. Standpipe systems and equipment, whether required by this code or not, shall be maintained in an operable condition.

History: 1-2-56; r. and recr. Register, December, 1976, No. 252, eff. 1-1-77; am. (7), Register, December, 1978, No. 276, eff. 1-1-79; am. (3) (i), Register, June, 1983, No. 330, eff. 7-1-83; emerg. renum. (6) and (7) to be (7) and (8), cr. (2) (d) and (6), eff. 9-6-86; renum. (6) and (7) to be (7) and (8), cr. (2) (d) and (6), Register, November, 1986, No. 371, eff. 12-1-86.

ILHR 51.22* Fire extinguishers. (1) GENERAL. All required fire extinguishers shall be approved by the department, and shall comply with the provisions of NFPA No. 10-1981 — Standard for Portable Fire Extinguishers.

(2) INSTALLATION. Fire extinguishers as specified in chs. ILHR 54-62 shall be installed as specified in NFPA No. 10-1981 — Standard for Portable Fire Extinguishers.

(3) MAINTENANCE. All portable fire extinguishers, whether required by chs. ILHR 54-62 or not, shall be maintained in operable condition as specified in NFPA No. 10-1981 — Standard for Portable Fire Extinguishers.

History: 1-1-56; am. Register, October, 1967, No. 142, eff. 11-1-67; r. and recr. Register, December, 1981, No. 312, eff. 1-1-82; am. Register, December, 1983, No. 336, eff. 1-1-84.

ILHR 51.23 Automatic sprinklers. (1) GENERAL REQUIREMENTS. (a) Except as permitted in chs. ILHR 54 to 62, all automatic fire sprinkler systems shall be designed and installed in accordance with NFPA No. 13, Standard for the Installation of Sprinkler Systems.

(b) The sprinkler system shall be so installed and maintained as to provide complete coverage for all portions of the building.

Note: See ch. Ind 4 for requirements pertaining to automatic fire sprinkler system protection for elevators.

(c) Reinstallation of used sprinkler heads shall be prohibited.
(d) Approved secondhand devices other than sprinkler heads may be installed by special permission of the department.

Note: The department will accept equipment, materials and devices listed or labeled by Underwriters' Laboratories or approved by Factory Mutual. Other testing laboratories or inspection agencies will be recognized as an approved agency if accepted in writing by the department.

(2) WATER SUPPLY. (a) Approved automatic water supplies for the FP sprinkler system recognized by the department are listed below:

- 1. City water main;
- 2. Gravity or pressure tank;
- 3. Ground storage reservoir; or
- 4. Natural bodies of water approved by the department (lakes, rivers, streams, etc.).

(b) If the water supply has inadequate pressure, an approved fire pump or tank shall be provided. The design and installation of water supply facilities for gravity tanks, fire pumps, reservoirs or pressure tanks, and underground piping shall conform to NFPA No. 22, Standard

*See Appendix A for further explanatory material.

92

WISCONSIN ADMINISTRATIVE CODE

ILHR 51

Definitions and standards

for Water Tanks for Private Fire Protection; NFPA No. 20, Installation of Centrifugal Fire Pumps; and NFPA No. 24, Outside Protection.

(3) **BASEMENT SPRINKLERS.** Every basement sprinkler system shall also include sprinklers in all shafts (except elevator shafts) leading to the story above.

(4) **FIRE DEPARTMENT CONNECTION.** Except as provided in s. ILHR 57.016 (1) (a), every automatic fire sprinkler system installed in accordance with NFPA No. 13 shall have an approved fire department connection as specified in NFPA 13-1980. The connection shall be marked "Sprinkler". If standpipes are also supplied by the hose connection, the sign shall read "Standpipe and Automatic Sprinkler". The elevation of the connection shall be not less than 18 inches nor more than 42 inches above the sidewalk or ground. If municipal water is available at the building site, the fire department connection shall be located within 150 feet of a municipal fire hydrant.

(5) **SPRINKLER ALARMS.** Every sprinkler system shall be provided with a suitable audible alarm. In all buildings over 60 feet in height, each sprinkler system on each floor shall be equipped with a separate water flow device connected to an alarm system.

(6) **MAINTENANCE.** (a) All installed automatic sprinkler systems, whether required by this code or not, shall be properly maintained for efficient service pursuant to NFPA No. 13A — Standard for the Care Inspection Testing and Maintenance of Sprinkler Systems. Owners or operators shall be responsible for the condition of their sprinkler system and shall use due diligence in keeping the system in good operating condition. A copy of the inspection report as specified in NFPA No. 13A shall be kept and shall be made available, upon request, to the department or its authorized deputies. The local fire department shall be notified whenever the automatic fire sprinkler system is shut down or impaired and when it is placed back in service. The owner shall arrange for immediate and continual servicing or repair of the automatic fire sprinkler system until it is placed back in operation.

(b) The requirements of par. (a) shall apply to all buildings in existence on the effective date of this section and to those buildings constructed thereafter.

Note: See ss. ILHR 81.10 (6) and 81.11 (9) and s. 145.165, Stats., for additional requirements pertaining to maintenance and repair of automatic fire sprinkler systems.

(7) **PARTIAL AUTOMATIC FIRE SPRINKLER SYSTEMS.** Partial automatic fire sprinkler systems may be connected without a fire department connection to the domestic water supply service or a first-aid standpipe or a fire department standpipe provided the following conditions are satisfied:

(a) The number of sprinkler heads per building does not exceed 20;

(b) The connection is equipped with an approved indicating valve with a monitor or an approved locking device and a check valve;

(c) The water pressure and volume is adequate to supply the required flow of the largest number of sprinkler heads in any one of the enclosed areas; and

INDUSTRY, LABOR & HUMAN RELATIONS 93
 Definitions and standards ILHR 51

(d) An audible alarm is provided to sound when the system is in operation.

Note: See ch. ILHR 82 for requirements pertaining to cross connections.

(8) **SUBSTITUTE AUTOMATIC FIRE SUPPRESSION SYSTEMS.** When approved by the department, substitute automatic fire suppression systems may be used in lieu of an automatic fire sprinkler system in areas where the use of water could cause unusual damage to equipment, or where water may have a limited effect or may be hazardous to use because of the nature of processes involved.

(9) **SYSTEM SUPERVISION AND MONITORING.** The height limitations and fire resistive ratings in ss. ILHR 51.02 (21) and (22) and the unlimited area buildings specified in chs. ILHR 54 to 62 shall be permitted only where the automatic fire sprinkler system is equipped with supervised sprinkler system valves or other approved component indicators, such as but not limited to fire pump power indicator or low water level indicator. The supervision function of the automatic fire sprinkler system shall be monitored by a central station, remote, auxiliary or proprietary fire alarm system company.

History: 1-2-56; r. and recr. Register, December, 1974, No. 228, eff. 1-1-75; cr. (7) (a), Register, December, 1976, No. 252, eff. 1-1-77; am. (6), Register, December, 1981, No. 312, eff. 1-1-82; r. and recr. (1), (4), (6) and (7), cr. (8), Register, June, 1983, No. 330, eff. 7-1-83; am. (6), Register, December, 1983, No. 336, eff. 1-1-84; emerg. am. (1) (a), (4) and (6) (a), cr. (9), eff. 9-6-86; am. (1) (a), (4) and (6) (a), cr. (9), Register, November, 1986, No. 371, eff. 12-1-86.

ILHR 51.24 Fire alarm systems. Interior fire alarm systems required under ss. ILHR 54.17, 56.19 and 57.17 shall be designed and constructed in conformity with the following requirements:

(1) All such alarm systems shall consist of operating stations on each floor of the building, including the basement, with bells, horns, or other approved sounding devices which are effective throughout the building. The system shall be so arranged that the operation of any one station will actuate all alarm devices connected to the system except in the case of a presignal system. Fire alarms shall be readily distinguishable from any other signalling devices used in the building. A system designed for fire alarm and paging service may be used if the design is such that fire alarm signals will have precedence over all others;

(a) In all buildings where a fire alarm system and a complete automatic sprinkler system are required, a water flow detecting device shall be provided to actuate the fire alarm system.

(2) Every fire alarm system shall be electrically operated or activated by non-combustible, nontoxic gas. Electrically operated systems shall be operated on closed circuit current under constant electrical supervision, so arranged that upon a circuit opening and remaining open or in case of a ground or short circuit in the undergrounded conductor, audible trouble signals will be given instantly. Gas-activated systems shall be mechanically supervised and under constant gas pressure, so arranged that in case of a pressure drop an audible trouble signal will be given instantly. Means shall be provided for testing purposes;

(3) (a) Except as provided in par. (b), coded fire alarm systems shall be provided in buildings more than 3 stories in height and the systems shall be so arranged that the code transmitted shall indicate the location and story of the structure in which the signal originated.

94 WISCONSIN ADMINISTRATIVE CODE

ILHR 51

Definitions and standards

(b) 1. The department shall approve non-coded continuous sounding fire alarm systems under constant automatic supervision in apartment buildings.

2. The department shall approve non-coded continuous or march time sounding fire alarm systems with electrically supervised annunciator panels that indicate the location and the story of the structure in which the signal originated.

3. The department shall approve fire alarm and communication systems for high rise construction as specified in s. ILHR 52.01 (2) (e).

(b) The department shall approve noncoded continuous sounding fire alarm systems under constant electric or gas activated supervision in apartment buildings.

(4) Operating stations shall be prominently located in an accessible position at all required exit doors and required exit stairways. Operating stations shall be of an approved type and shall be conspicuously identified. All such operating stations shall be of a type, which after being operated, will indicate that an alarm has been sent therefrom until reset by an authorized means. (Operating stations having a "Break Glass" panel will be acceptable. On coded systems having a device to permanently record the transmission of an alarm, "Open Door" type stations may be used). The fire alarm operating stations shall be mounted not less than 3 feet nor more than 4 feet above the finished floor as measured from the floor to the center of the box;

FP (5) All alarm systems shall be tested at least once a month and a record of the tests shall be kept;

(6) Existing fire alarm systems that are effective in operation will be accepted if approved by the department;

(7) The gas for operation of non-combustible, non-toxic gas activated fire alarm systems shall be supplied from approved pressure cylinders on the premises. The cylinders shall have sufficient capacity and pressure to properly operate all sounding devices connected to the system for a period of not less than 10 minutes. Cylinders shall be removed for recharging immediately after use and shall be replaced by fully charged cylinders;

(8) Spare cylinders shall be kept on the premises at all times for immediate replacement and separate cylinders for testing shall be incorporated in the system;

(9) Tubing in connection with non-combustible, non-toxic gas activated fire alarm systems shall be installed in rigid metal conduit, flexible metal conduit, or surface metal raceways where subject to mechanical injury. Non-corrosive metallic tubing not less than 3/16" in diameter which will withstand a bursting pressure of not less than 500 pounds per square inch shall be used. The maximum length of 3/16" tubing shall not exceed 300 feet between charged cylinders. All tubing and other component parts shall be installed by skilled workers in accordance with the provisions of this code; and

Note: See Wisconsin State Electrical Code, Volume 2, ch. ILHR 16.

Register, November, 1986, No. 371

INDUSTRY, LABOR & HUMAN RELATIONS 94-1
Definitions and standards ILHR 51

(10) MAINTENANCE. All fire alarm systems, whether required by this FP code or not, shall be maintained in an operable condition.

History: 1-2-56; am. (4) (a), Register, November, 1963, No. 95, eff. 12-1-63; am. Register, August, 1964, No. 104, eff. 9-1-64; r. (10), (11) and (12), Register, December, 1975, No. 240, eff. 1-1-76; cr. (1) (a) and am. intro. and (2), Register, December, 1976, No. 252, eff. 1-1-77; am. (intro.) and (4), r. (3) (a), Register, January, 1980, No. 289, eff. 2-1-80; am. (3) and (6), cr. (10), Register, December, 1981, No. 312, eff. 1-1-82; am. (5), Register, August, 1985, No. 356, eff. 1-1-86; emerg. r. and recr. (3), eff. 9-6-86; r. and recr. (3), Register, November, 1986, No. 371, eff. 12-1-86.

ILHR 51.245 Smoke detectors. (1) GENERAL REQUIREMENTS. All required smoke detectors shall be approved by the department and shall comply with the provisions of NFPA No. 72E-1982 — Standard on Automatic Fire Detectors or NFPA No. 74-1980 — Household Fire Warning Equipment.

(2) INSTALLATION. (a) Smoke detectors and smoke detector systems shall be installed in accordance with the provisions of NFPA No. 72E-1982 — Standard on Automatic Fire Detectors or NFPA No. 74-1980 — Household Fire Warning Equipment and in accordance with the manufacturer's directions and specifications. FP

(b) Except as provided in s. ILHR 57.16 (2) (b), all smoke detectors interconnected with each other or with the manual fire alarm system shall be installed in accordance with the provisions of NFPA No. 72A-1979 — Standard for the Installation, Maintenance and Use of Local Protective Signaling Systems for Guard's Tour, Fire Alarm and Supervisory Service. Where smoke detectors are interconnected with the manual fire alarm system, the smoke detectors shall be wired in accordance with the provisions specified in s. ILHR 16.34.

(3) MAINTENANCE. (a) The owner shall be responsible for maintaining the smoke detectors and the smoke detection system in good working order. FP

(b) Tenants shall be responsible for informing the owner, in writing, of any smoke detector malfunction, including the need for a new battery.

(c) The owner shall have 5 days upon receipt of written notice from the tenant to repair or replace the smoke detector or replace the battery. The owner shall check batteries at the beginning of a new lease and shall replace the battery at least annually.

(d) The owner shall furnish to the tenant written notice of the responsibilities of the tenant and the obligations of the owner regarding smoke detector maintenance.

History: Cr. Register, December, 1981, No. 312, eff. 1-1-82; am. (2) and (3) (c), Register, October, 1982, No. 322, eff. 11-1-82; am. (1) and (2) (a) Register, December, 1983, No. 336, eff. 1-1-84.

A14.124 AUTOMATIC FIRE SPRINKLER SYSTEMS. The following is a reprint of NFPA No. 13A as adopted by reference in s. ILHR 51.27 (7) of the Wisconsin Building and Heating, Ventilating and Air Conditioning Code:

Recommended Practice for the Inspection, Testing and Maintenance of Sprinkler Systems

NFPA 13A-1981

NOTICE: Information on referenced publications can be found in the Appendix.

Foreword

An automatic sprinkler system provides for the extinguishment of fire in a building by the prompt and continuous discharge of water directly upon burning material. This is accomplished by means of an arrangement of pipes to which are attached outlet devices known as automatic sprinklers. These sprinklers are so constructed as to open automatically whenever the surrounding temperature reaches a predetermined point.

In general, there are two types of automatic sprinkler equipment, dry-pipe systems and wet-pipe systems. In locations which are not subject to freezing temperatures, wet-pipe systems, in which the pipe lines contain water under pressure, may be installed, but in buildings or portions thereof which are subject to freezing temperatures, the dry-pipe system is ordinarily used. In the latter type of system, water is admitted to the pipes automatically after elevated ceiling temperature has caused the automatic sprinkler to operate.

If not properly maintained, a sprinkler system may become inoperative. The following offers advice and suggestions relative to the inspection, testing and maintenance of sprinkler equipment upon which the safety of life and property may depend.

Chapter I General Information

1-1 Scope. This recommended practice provides for the inspection, testing and maintenance of sprinkler systems.

1-2 Purpose. The purpose of this recommended practice is to provide guidance for inspection, testing and maintenance of sprinkler systems.

1-3 Definitions.

Antifreeze System. Antifreeze system means a system employing automatic sprinklers attached to a piping system containing an antifreeze solution and connected to a water supply. The antifreeze solution, followed by water, discharges immediately from sprinklers opened by a fire.

Approved. Means "acceptable to the authority having jurisdiction."

NOTE: The National Fire Protection Association does not approve, inspect or certify any installations, procedures, equipment or materials nor does it approve or evaluate testing laboratories. In determining the acceptability of installations or procedures, equipment or materials, the authority having jurisdiction may base acceptance on compliance with NFPA or other appropriate standards. In the absence of such standards, said authority may require evidence of proper installation, procedure or use. The authority having jurisdiction may also refer to the listings or labeling practices of an organization concerned with product evaluations which is in a position to determine compliance with appropriate standards for the current production of listed items.

Authority Having Jurisdiction. The "authority having jurisdiction" is the organization, office, or individual responsible for "approving" equipment, an installation, or a procedure.

NOTE: The phrase "authority having jurisdiction" is used in NFPA documents in a broad manner since jurisdictions and "approval" agencies vary as do their responsibilities. Where public safety is primary, the "authority having jurisdiction" may be a federal, state, local, or other regional department or individual such as a fire chief, fire marshal, chief of a fire prevention bureau, labor department, health department, building official, electrical inspector, or others having statutory authority. For insurance purposes, an insurance inspection department, rating bureau, or other insurance company representative may be the "authority having jurisdiction." In many circumstances the property owner or his designated agent assumes the role of the "authority having jurisdiction"; at government installations, the commanding officer or departmental official may be the "authority having jurisdiction."

Butterfly Valve. An indicating-type control valve incorporating wafer-type body with gear-operated, quarter-turn disc in the waterway.

Cold Weather Valve. An indicating-type valve for the control of 10 sprinklers or less in a wet system protecting an area subject to freezing. The valve is normally closed and the system drained during freezing weather.

Control Valve. A valve which may be opened or closed to regulate the flow of water to all or part of a sprinkler system.

Deluge System. A system employing open sprinklers installed in a water supply through a valve which is opened by the operation of a fire detection system installed in the same areas as the sprinklers. When this valve opens, water flows into the piping system and discharges from all sprinklers attached thereto.

Dry-Pipe System. A system employing automatic sprinklers installed in a piping system containing air or nitrogen under pressure, the release of which, as from the opening of a sprinkler, permits the water pressure to open a valve known as a dry-pipe valve. The water then flows into the piping system and out the opened sprinklers.

Emergency Impairment. A condition wherein a sprinkler system or a portion thereof is out of order due to an unexpected occurrence such as a ruptured pipe, operated sprinkler, interruption of water supply to the system, etc.

Indicator Post. A control extending above ground or

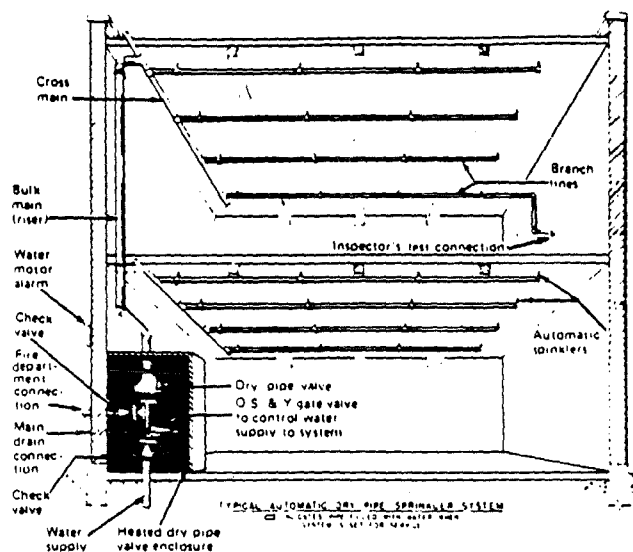

Figure 1-3(a) Dry-pipe system.

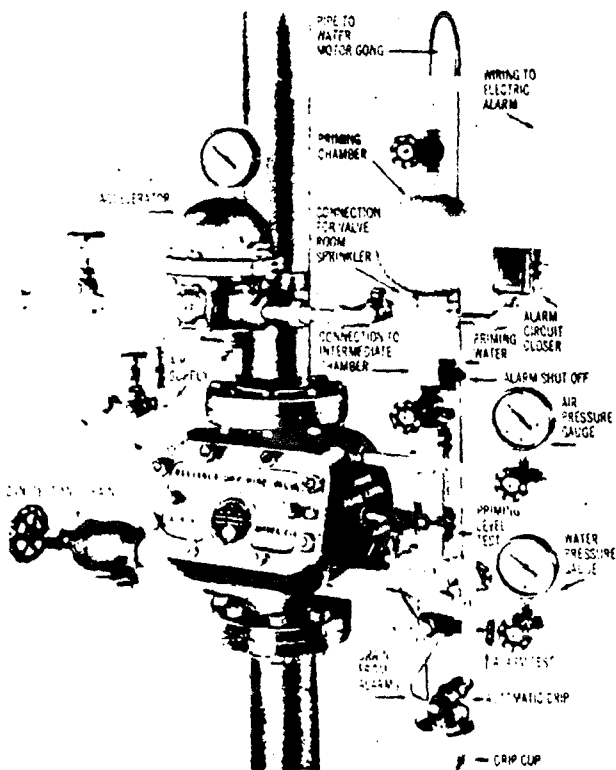

Figure 1-3(b) Typical dry-pipe valve with trimmings.

through a wall for operating sprinkler control valves. A target or indicator visible through an opening in the post shows whether the valve is open or shut.

Inspection. A visual examination of a sprinkler system or portion thereof to verify that it appears to be in operating condition and is free from physical damage.

Listed. Equipment or materials included in a list published by an organization acceptable to the "authority having jurisdiction" and concerned with product evaluation, that maintains periodic inspection of production of listed equipment or materials and whose listing states either that the equipment or material meets appropriate standards or has been tested and found suitable for use in a specified manner.

NOTE: The means for identifying listed equipment may vary for each organization concerned with product evaluation, some of which do not recognize equipment as listed unless it is also labeled. The "authority having jurisdiction" should utilize the system employed by the listing organization to identify a listed product.

Locks and Chains. Heavy-duty locks and chains sufficiently durable to resist any cutting device less than heavy-duty bolt cutters.

Maintenance. Work performed to keep equipment operable, or to make repairs.

Outside Screw and Yoke (O. S. & Y.) Valve. A gate valve with a rising stem which indicates if the valve is open or closed.

Pre-Action System. A closed sprinkler system containing air that may or may not be under pressure, with a supplemental fire detection system installed in the same areas as the sprinklers. Actuation of the fire detection system opens a valve which permits water to flow into the sprinkler piping and to be discharged from any sprinklers which may be open.

Pre-Planned Impairment. A condition where a sprinkler system or a portion thereof is out of service due to work which has been planned in advance such as revisions to the water supply or sprinkler system piping.

Qualified Inspection Service. A service program provided by a fire protection contractor and/or owner's representative in which all of the Chapter 7 provisions are included.

Quick-Opening Device. A listed device such as an accelerator or an exhauster used to cause a dry-pipe valve to operate more rapidly.

Roadway Box. A sleeve providing access to an underground control valve.

Seals. The use of small-diameter wire which is threaded and knotted within a lead seal. Alternately, plastic devices are available for the same purpose.

The closing of the seal makes it impossible to turn a valve unless the seal is broken. The broken seal indicates that the valve may have been moved from its normal position.

Should. Indicates a recommendation or that which is advised but not required.

Sprinkler System. A sprinkler system, for fire protection purposes, is an integrated system of underground and overhead piping designed in accordance with fire protection engineering standards. The installation in-

cludes a water supply such as a gravity tank, fire pump, reservoir or pressure tank and/or connection by underground piping to a city main. The portion of the sprinkler system aboveground is a network of specially sized or hydraulically designated piping installed in a building, structure or area, generally overhead, and to which sprinklers are connected in a systematic pattern. The system includes a controlling valve and a device for actuating an alarm when the system is in operation. The system is usually activated by heat from a fire and discharges water over the fire area.

Tamper Switch. An electrical device for control-valve supervision which initiates an alarm when the control valve is moved from the normal position.

Testing. Conducting periodic physical checks on the sprinkler system such as water flow tests, alarm tests, or dry-pipe valve trip tests.

Waterflow Alarm. A listed device so constructed and installed that any flow of water from a sprinkler system equal to or greater than that from a single automatic sprinkler will result in an alarm signal.

Wet-Pipe System. A system employing automatic sprinklers installed in a piping system containing water and connected to a water supply. Water discharges immediately from sprinklers opened by a fire.

1-4 Units. Metric units of measurement in this recommended practice are in accordance with the modernized metric system known as the International System of Units (SI). Two units (liter and bar), outside of but recognized by SI, are commonly used in international fire protection. These units are listed in Table 1-4 with conversion factors.

Table 1-4

Name of Unit	Unit Symbol	Conversion Factor
liter	L	1 gal = 3.785 L
cubic decimeter	dm ³	1 gal = 3.785 dm ³
pascal	Pa	1 psi = 6894.757 Pa
bar	bar	1 psi = 0.0689 bar
bar	bar	1 bar = 10 ⁵ Pa

For additional conversions and information see ASTM E380, *Standard for Metric Practice*.

1-4.1 If a value for measurement as given in this recommended practice is followed by an equivalent value in other units, the first stated is to be regarded as the requirement. A given equivalent value may be approximate.

1-4.2 The conversion procedure for the SI units has been to multiply the quantity by the conversion factor and then round the result to the appropriate number of significant digits.

1-5 Responsibility of the Owner or Occupant.

1-5.1 The responsibility for properly maintaining a sprinkler system is the obligation of the owners of the property.

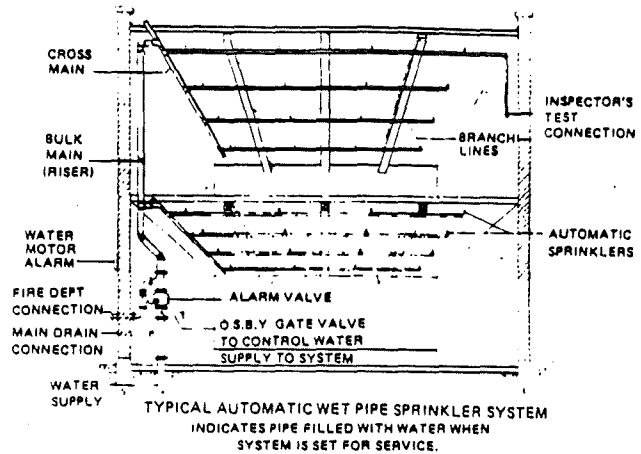

Figure 1-3(c) Wet-pipe system.

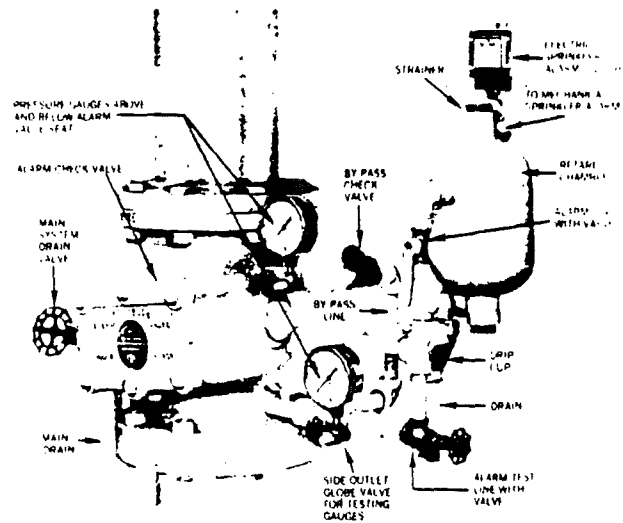

Figure 1-3(d) Typical alarm valve and trimmings.

By means of periodic tests, the equipment is shown to be in good operating condition or any defects or impairments are revealed. Such tests are made, however, at the owner's responsibility and risk. Intelligent cooperation in the performance of these tests shows evidence of the owner's interest in property conservation.

1-5.2 Automatic sprinkler systems installed in accordance with NFPA standards require a minimum of inspection, testing and maintenance; however, deterioration or impairment may result from neglect. Definite provision for periodic competent attention is a prime requirement if the system is to serve its purpose effectively.

1-5.3 Arrangements should be made to keep all stock piles, racks and other possible obstructions the proper distance below sprinklers. [The minimum recommended distance below sprinkler deflectors at the ceiling is 18 in. (457 mm). The minimum recommended distance below sprinkler deflectors in racks can be found in NFPA 231, *Standard for General Storage*; NFPA 231C, *Standard for*

Rack Storage; and NFPA 231D, Standard on Storage of Rubber Tires.]

1-5.4 A competent and reliable employee should be given the responsibility of regularly inspecting, testing and maintaining the system and reporting any troubles or defects to his employer. This employee should have proper instruction and training and a general understanding of the mechanical requirements of operation.

1-5.5 Support personnel should be trained in inspection, testing and maintenance and be fully capable of taking over the functions at any time when the authorized individual is unavailable.

1-5.6 Public Fire Department.

1-5.6.1 It is advisable to notify the fire department of the installation of automatic sprinkler equipment so that it may become familiar with the system. The fire department should know the extent of the protection and the location and arrangement of the control valves and the connections for fire department use.

1-5.7 Security Personnel.

1-5.7.1 Instruct security personnel in the following:

- (a) Location and use of control valves, drain valves and alarm devices.
- (b) Prompt transmittal of a fire alarm to a fire department or brigade, before attempting to extinguish the fire.
- (c) Proper notification in case of fire or impairment of sprinkler equipment.
- (d) Daily visual inspection of all sprinkler control valves on the guard's first round to ascertain that they are open.
- (e) Proper notification immediately of any valve found closed.
- (f) Proper notification when sprinkler alarms operate, to determine the cause of water flow.
- (g) Do not close sprinkler control valves until it has definitely been established that there is no fire.
- (h) During cold weather, verify that windows or other openings are closed and that proper temperature is being maintained to prevent freezing.

1-6 Sprinkler Inspection Service.

1-6.1 The level of reliability of the protection offered by an automatic sprinkler system is promoted when there is a qualified inspection service. Qualified inspection service should include:

- (a) Four visits per year, at regular intervals.
- (b) All services indicated in summary Table 7-3.
- (c) The completion of a report form with copies furnished to the property owner. (*See Chapter 7, Report of Inspection, Exhibit I.*)

1-6.2 The outside inspection services are an adjunct to, and are not intended to replace, the owners' obligations.

Chapter 2 Water Supplies

2-1 General. The source and quantity of water is of fundamental importance. To ensure the continued existence of proper flow, it is necessary that periodic inspections and tests be conducted by qualified personnel.

2-2 Gravity Tanks and Suction Tanks. (*See NFPA 22, Standard for Water Tanks for Private Fire Protection.*)

2-2.1 Monthly inspections should be made to check the maintenance of water at proper level in the tank.

Constant maintenance of a full supply of water in gravity tanks is necessary not only to ensure proper performance of the sprinkler system in the event of a fire, but to prevent shrinkage of wooden tanks and minimize corrosion of steel tanks.

2-2.2 Heating devices should be kept in order and the water temperature in the tank should be checked daily during freezing weather to maintain a minimum temperature of 40°F (4°C).

2-2.3 The tank roof should be kept tight and in good repair, with the hatches fastened closed and the frostproof casing of the tank riser in good repair.

2-2.4 Ice should not be allowed to form on any part of the tank structure. The prevention of freezing in the riser or the formation of ice in the tank itself is extremely important. Freezing in the riser of an elevated tank may obstruct the flow of water from the tank. The formation of a layer of ice on the water of elevated or suction tanks also may impede or prevent the flow from the tank. The formation of heavy icicles through leaking of the tank is dangerous as tank collapse may ensue or people may be endangered by falling icicles.

2-2.5 The bases of the tower columns should be kept free from dirt and rubbish which would otherwise permit the accumulation of moisture with consequent corrosion. The tops of foundation piers should always be at least 6 in. (152 mm) above the ground level.

Coal or ashes or combustible material of any kind should not be piled near the columns as this may cause failure of the steel work due to fire, heating or corrosion. The tank site should be kept cleared of weeds, brush, and grass.

2-2.6 Before repainting, the surface should be thoroughly dried and all loose paint, rust, scale and other surface contamination should be removed. After proper surface preparation, the original paint system should be restored. It may be necessary or economical to repaint the entire inside surface. On the exterior, normal maintenance will involve local patching and periodic application of one complete finish coat when the preceding has weathered thin or for improved appearance after patching.

The painters should not allow any scrapings or other foreign material to fall down the riser or outlet. If the opening is covered for protection, only a few sheets of

paper tied over the end of the settling-basin-stub should be used. The paper should be removed upon the completion of the job.

For detailed information refer to NFPA 22, *Standard for Water Tanks for Private Fire Protection*, Care and Maintenance Section.

2-2.7 Necessary periodic emptying of steel tanks for repainting can be minimized by use of a cathodic corrosion prevention system that counteracts the natural electrolytic action that is the basis for most corrosion. Such a system needs periodic attention to the condition of suspended electrodes. If chemical water additives are used to inhibit corrosion, semi-annual chemical analysis of the water should be made. (See also NFPA 22, *Standard for Water Tanks for Private Fire Protection*, Section A-2-7.13.)

If cathodic protection is maintained in a steel tank, the tank should be cleaned out sufficiently often to prevent sediment and scale entering the discharge pipe.

2-2.8 The authority having jurisdiction should always be notified in advance when and for how long the tank is to be out of service.

2-3 Pressure Tanks. (See NFPA 22, *Standard for Water Tanks for Private Fire Protection*.)

2-3.1 Pressure tanks should be inspected regularly, checking the water level and air pressure monthly.

2-3.2 The interior of pressure tanks should be inspected carefully at three-year intervals to determine if corrosion is taking place and if repainting or repairing is needed. When necessary, they should be thoroughly scraped and wire brushed and repainted with an approved metal-protective paint.

2-3.3 Applicable safety codes should be consulted with respect to the maintenance and testing of pressure tanks.

2-3.4 The tank should be pressure tested at intervals as required by the ASME, *Non-Fired Pressure Vessel Code*.

2-3.5 Sight gage valves should be kept closed except when test for water level is being made.

2-3.6 The tank and its supports should be examined and painted as recommended for gravity tanks.

2-3.7 The heat within the tank enclosure should be checked daily during cold weather to maintain a 40°F (4°C) room temperature.

2-4 Fire Pumps. (See NFPA 20, *Standard for Installation of Centrifugal Fire Pumps* and NFPA 21, *Standard for the Operation and Maintenance of National Standard Steam Fire Pumps*.)

2-4.1 General.

2-4.1.1 The pump room should be kept clean and accessible at all times. The fire pump, driver and controller should be protected against possible interruption of service through damage caused by explosion, fire, flood,

earthquake, rodents, insects, windstorm, freezing, vandalism and other adverse conditions.

2-4.1.2 The suction pipes, intakes, foot valves, and screens of fire pumps should be examined frequently to make sure that they are free from any obstruction. Mud, gravel, leaves and other foreign material entering the suction pipe may cause damage to the pump or obstruction of the piping of the sprinkler system. The formation of ice may also impair the operation of the pump.

NOTE: Horizontal pumps should be provided with water under a positive head.

2-4.1.3 Suitable means should be provided for maintaining the temperature of a pump room or pump house, where required, above 40°F (4°C). Where pumps are driven by internal combustion engines the temperature of the pump room, pump house, or area where engines are installed should never be less than the minimum recommended by the engine manufacturer.

2-4.1.4 Pump rooms and pump houses should be dry and free of condensate. Accumulation of water in the steam pump supply line or drainage equipment may be dangerous and should be avoided. Where condensate is a problem some heat should be provided.

2-4.1.5 Fire pumps should be operated only in connection with fire protection service and not for plant use.

2-4.1.6 Oil in internal combustion engine pumps should be changed in accordance with manufacturer's instructions, but not less than annually.

2-4.1.7 Storage batteries should be tested frequently to determine the condition of battery cells and the amount of charge in the battery. Only distilled water should be used in battery cells. The plates should be kept submerged at all times.

2-4.1.8 Fuel storage tanks should be kept full at all times.

2-4.2 Periodic Operation and Testing.

2-4.2.1 The pump should be operated every week at rated speed. Inspect the condition of the pump, bearings, stuffing boxes, suction pipe strainers and the various other details pertaining to the driver and control equipment. The examination should be extended to include the condition and reliability of the electric power supply and, if the pump is engine driven, the storage batteries, lubricated system and oil and fuel supplies.

Exception: Electric motor driven fire pumps should be tested monthly.

2-4.2.2 When automatically controlled pumping units are to be tested weekly by manual means, at least one start should be accomplished by reducing the water pressure either with the test drain on the pressure sensing line or with a larger flow from the system.

2-4.2.3 If the driver has an internal combustion engine, it should be run for at least 30 minutes to bring it up to normal running temperature and to make sure it is running smoothly at rated speed. Automatically controlled

equipment should be arranged to automatically start the engine with the initiating means being a solenoid valve drain on the pressure control line.

2-4.2.4 Steam pumps should be operated until water is discharged freely from the relief valve. Regular inspections should be made: checking the maintenance of ample pressure; proper supply of lubricating oil; operative condition of relief valve and level of water in the priming tank.

2-4.2.5 A yearly flow test should be made to make sure that neither pump nor suction pipe is obstructed and the pump is operating properly. When the water supply is from a public service main, pump operation should not reduce the suction head at the pump below the pressure allowed by the local authority. At this time both the static and pumping water level of vertical shaft pumps should be determined.

2-5 Hydrants. (See NFPA 24, *Standard for Private Fire Service Mains and Their Appurtenances.*)

2-5.1 Inspection of Hydrants.

(a) Public hydrants near the building should be observed for any signs of damage or vandalism.

(b) Private hydrants should be inspected monthly to verify that they are visible and readily accessible with caps in place.

2-5.2 Maintenance.

(a) Lubricate private hydrants twice yearly.

(b) Private hydrants should be serviced as recommended by manufacturers.

2-5.3 Testing. At least annually, private hydrants should be opened and closed to ensure proper water flow and drainage.

2-6 Riser Flow Tests.

2-6.1 Water flow tests should be made quarterly from water supply test pipes (main drain valves).

Test at the main drain valves includes noting of pressure gage readings with unrestricted flow of water with the drain valve wide open, as compared with the reading with the drain valve closed. If the readings vary materially from those previously established or from normal readings, the condition should be investigated. These tests are intended to show whether or not the normal water supply is available on the system and to indicate the possible presence of closed valves or other obstructions in the supply pipe.

NOTE: Water flow test of a system having a direct connection to central station or fire department should be made only after proper notice is given to the signal receiving station.

2-7 Control Valves. (See NFPA 26, *Recommended Practices for the Supervision of Valves Controlling Water Supplies for Fire Protection.*)

2-7.1 General.

2-7.1.1 Valves should be numbered and each should have a sign indicating the portion of the system it controls.

2-7.1.2 A valve seal and tag system should be used in connection with the supervision and maintenance of a sprinkler system.

2-7.1.3 Each control valve in the sprinkler system should be secured in its normal or open position by means of a seal, lock, or tamper switch.

2-7.1.4 All control valves of the sprinkler system should be inspected at regular intervals.

(a) Sealed valves — weekly

(b) Locked valves and valves with tamper switches — monthly.

2-7.1.5 If a normally open sprinkler valve is closed, shutting off any part of the system, the owner or manager of the property should be notified immediately so that the owner may follow his normal valve supervision procedure, including notifying the authority having jurisdiction. (See Chapter 6, *Impairments.*)

2-7.1.6 Valves should be kept in normal position and the sprinkler system in service to the greatest extent possible during alterations and repairs.

2-7.1.7 After any alterations or repairs, an inspection should be made to ensure that the valves are in the fully open position, properly sealed, locked or equipped with a tamper switch, and the system is in commission.

2-7.1.8 Valve stems should be oiled or greased at least once a year. At this time, completely close and reopen the valve to test its operation and distribute the lubricant.

2-7.2 Valve Inspection Report.

2-7.2.1 A valve inspection report should show that the valves are:

(a) In normal open or closed position

(b) Properly sealed, locked, or equipped with a tamper switch

(c) In good operating condition

(d) Readily accessible

(e) Provided with wrenches where required.

2-7.3 Indicator Post.

2-7.3.1 Quarterly, each post indicator valve should be opened until spring or torsion is felt in the rod assuring that the rod has not become detached from the valve. Valves should be backed one-quarter turn from the wide open position to prevent jamming.

2-7.4 Underground Gate Valves with Roadway Boxes.

2-7.4.1 Quarterly, each valve should be operated with a T-handle wrench to verify that it is in the open position.

2-7.4.2 The location of each such valve should be clearly indicated by a sign on a nearby wall or by a marker. The sign should also indicate direction of valve opening, clockwise or counterclockwise.

2-7.4.3 The roadway box for the valve should always be

readily accessible, and the cover should be kept in place.

2-8 Fire Department Connections.

2-8.1 Fire department connections should be visible and accessible at all times. They should be inspected monthly.

2-8.2 Caps or plugs should be in place, threads in good condition, ball drip or drain in working order, and check valve not leaking. Prior to replacing caps or plugs, ensure that waterway is clear of foreign material.

2-9 Hose and Hose Stations. (See NFPA 1962, *Standard for the Care, Use and Maintenance of Fire Hose Including Connections and Nozzles.*)

2-9.1 Hose stations should be inspected monthly to ensure that all equipment is in place and in good condition. Hose racks or reels and nozzles should be checked for obvious signs of mechanical damage. Hose station control valves should be checked for signs of leakage.

2-9.2 Hose including gaskets should be removed and re-racked at least annually.

Chapter 3 Automatic Sprinklers

3-1 General.

3-1.1 Sprinklers should be visually checked regularly. Sprinklers should be free from corrosion, foreign material, and paint, and not bent or damaged.

3-1.2 The standard sprinkler is the type manufactured since 1953, incorporating a uniform, hemispherical discharge pattern. Water is discharged in all directions below the plane of the deflector. Little or no water is discharged upward to wet the ceiling. Sprinkler deflectors are stamped as follows:

- Upright Sprinkler Marked SSU
- Pendent Sprinkler Marked SSP

3-1.3 The old style sprinkler is the type manufactured before 1953. It discharged approximately 40 percent of the water upward to the ceiling. It can be installed in either the upright or pendent position.

3-1.4 Only listed sprinklers may be used. Sprinklers may not be altered in any respect nor have any type of ornamentation, paint or coatings applied after shipment from the place of manufacture.

3-1.5 Corrosion resistant or specially coated sprinklers are installed in locations where chemicals, moisture or other corrosive vapors exist.

3-1.6 Temperature Ratings.

3-1.6.1 The standard temperature rating of automatic sprinklers is shown in Table 3-1.6.1. Automatic sprink-

lers are manufactured with their frame arms colored in accordance with color code designated in Table 3-1.6.1.

Table 3-1.6.1
Temperature Ratings, Classifications and Color Codings

Maximum Ceiling Temperature		Temperature Rating		Temperature Classification	Color Code
°F	°C	°F	°C		
100	38	135 to 170	57 to 77	Ordinary	Uncolored
150	66	175 to 225	79 to 107	Intermediate	White
225	107	250 to 300	121 to 149	High	Blue
300	149	325 to 375	163 to 191	Extra High	Red
375	191	400 to 475	204 to 246	Very Extra High	Green
475	246	500 to 575	260 to 302	Ultra High	Orange

3-1.6.2 When higher temperature sprinklers are necessary to meet extraordinary conditions, special sprinklers as high as 650°F (343°C) are obtainable and may be used.

3-1.6.3 Information regarding the highest temperature that may be encountered in any location in a particular installation should be obtained by use of a thermometer that will register the highest temperature encountered, which should be hung for several days in the questionable location under the normal ambient temperature condition.

3-2 Replacement Sprinklers.

3-2.1 Care should be taken to ensure that replacement sprinklers have the proper characteristics for the location:

- (a) Style
- (b) Orifice size
- (c) Temperature rating
- (d) Coating, if any
- (e) Deflector type (upright, pendent, sidewall, etc.).

3-2.2 Standard sprinklers manufactured after 1952 may be used to replace old style sprinklers manufactured prior to 1953.

Exception: Piers and wharves. See 3-16.2.8 of NFPA 13, Installation of Sprinkler Systems.

3-2.3 Old style sprinklers may be used to replace existing old style sprinklers.

3-2.4 Old style sprinklers should not be used to replace standard sprinklers without a complete engineering review of the system.

3-2.5 Secondhand sprinklers should not be used.

3-3 Automatic Sprinkler Replacement and Testing Program.

3-3.1 Representative samples of solder-type sprinklers with temperature classification of Extra High (325°F)(163°C) or greater which are exposed on a semicontinuous to continuous maximum allowable ambient temperature condition should be tested at 5-year intervals for operation by a testing laboratory acceptable to the authority having jurisdiction.

3-3.1.1 A representative sample of sprinklers should

normally consist of a minimum of two per floor or individual riser, and in any case not less than four, or 1 percent of the number of sprinklers per individual sprinkler system, whichever is greater.

3-3.2 All automatic sprinklers should be replaced when painted, corroded, damaged or loaded with foreign materials or when representative samples fail to pass test.

3-3.3 When sprinklers have been in service for 50 years, representative samples should be submitted to a testing laboratory acceptable to the authority having jurisdiction for operational testing. Test procedure should be repeated at 10-year intervals.

3-3.3.1 Sprinklers made previous to 1920 should be replaced.

3-4 Sprinkler Guards. Sprinklers which are so located as to be subject to mechanical injury should be protected with approved sprinkler guards.

3-5 Stock of Spare Sprinklers.

3-5.1 A supply of spare sprinklers (never less than six) should be stored in a cabinet on the premises for replacement purposes. The cabinet should be so located that it will not be exposed to moisture, dust, corrosion, or a temperature exceeding 100°F (38°C).

3-5.1.1 The stock of spare sprinklers should be as follows:

- (a) For buildings having not over 300 sprinklers - not less than 6 sprinklers
- (b) For buildings having 300 to 1,000 sprinklers - not less than 12 sprinklers
- (c) For buildings having over 1,000 sprinklers - not less than 24 sprinklers
- (d) Stock of spare sprinklers should include all types and ratings installed.

3-5.1.2 A special sprinkler wrench should be provided and kept in the cabinet, to be used in the removal and installation of sprinklers. Other types of wrenches may damage the sprinklers.

3-5.1.3 Automatic sprinklers and fusible links protecting commercial-type cooking equipment and their associated ventilation systems should be inspected twice yearly and replaced annually.

3-5.1.4 Sprinklers protecting spraying areas should be clean and protected against overspray residue so that they will operate quickly in event of fire. If covered, polyethylene or cellophane bags having a thickness of 0.003 in. (0.076 mm) or less, or thin paper bags should be used. Coverings should be replaced or heads cleaned frequently so that heavy deposits or residue do not accumulate. If not covered, the sprinklers should be replaced annually.

Chapter 4 Sprinkler System Components

4-1 General.

4-1.1 The sprinkler contractor provides instructional literature describing operation and proper maintenance of fire protection devices. This instructional literature should be posted near the system riser.

4-2 Piping.

4-2.1 General Provisions. Piping should be kept in good condition and free from mechanical injury. Sprinkler piping should not be used for support of ladders, stock or other material.

4-2.2 When the piping is subject to corrosive atmosphere, a protective coating that resists corrosion should be provided and maintained in proper condition.

4-2.3 When the age or service conditions of the sprinkler equipment warrant, an internal examination of the piping should be made. When it is necessary to flush a part or all of the piping system, this work should be done by sprinkler contractors or other qualified workers.

4-3 Hangers.

4-3.1 Hangers should be kept in good repair. Broken or loose hangers should be replaced or refastened.

4-3.2 Broken or loose hangers may put undue strain on piping and fittings, cause breaks, and interfere with proper drainage.

4-4 Gages.

4-4.1 Gages on wet-pipe sprinkler systems should be checked monthly to ensure that normal water supply pressure is being maintained. Gages on dry, pre-action and deluge systems should be inspected weekly to ensure that normal air and water pressures are being maintained.

4-4.2 Gages should be checked with an inspector's gage every five years.

4-5 Water Flow Alarm Devices.

4-5.1 Water-flow alarm devices include mechanical water motor gongs, vane-type water flow devices and pressure switches which provide audible and/or visual signals.

4-5.2 Valves controlling water supply to alarm devices should be sealed or locked in the normally open position.

4-5.3 Water-flow alarm devices should be tested at least quarterly, weather permitting.

4-6 Notification to Supervisory Service.

4-6.1 To avoid false alarms where supervisory service is provided, including proprietary, remote alarm receiving facility or fire department, the central station should always be notified before operating any valve or otherwise disturbing the sprinkler system.

4-7 Wet Systems — Alarm Valves.

4-7.1 Test alarms quarterly by opening the inspector's test connection.

Exception: Where weather conditions or other circumstances prohibit using the inspector's test connection, the by-pass test connection may be used.

4-7.2 Cold weather valves should be closed at the approach of freezing weather. Drain the piping in the area subject to freezing. The drain valves on the exposed piping should be left slightly open. (Automatic protection should be restored when danger of freezing is past.)

NOTE: To provide year-round protection, it is recommended that cold weather valves be replaced with dry-pipe valves or antifreeze systems.

4-7.3 The freezing point of solutions in antifreeze systems should be checked annually by measuring the specific gravity with a hydrometer, and adjusting the solutions if necessary. The use of antifreeze solutions should be in conformity with any state or local health regulations.

4-7.4 Buildings should be inspected to verify that windows, skylights, doors, ventilators, and other openings and closures will not unduly expose sprinkler piping to freezing. Blind spaces, unused attics, stair towers, low spaces under buildings and roof houses are often subject to freezing.

4-8 Dry Systems — Dry Valves, Accelerators, Exhausters.

4-8.1 Dry-pipe systems should not be converted to wet-pipe during warm weather. This will cause corrosion and accumulation of foreign matter in the pipe system and loss of alarm service.

4-8.2 Inspection and Maintenance.

4-8.2.1 The priming water should be inspected quarterly and maintained at the proper level as recommended by the dry valve manufacturer.

4-8.2.2 Grease or other sealing material must not be used on seats of dry-pipe valves. Force should not be used in attempting to make dry valves tight.

4-8.2.3 Test water flow and low air pressure alarms and perform a water-flow test through the main drain connection quarterly.

4-8.2.4 The air or nitrogen pressure on each dry-pipe system should be checked at least once a week and maintained as per manufacturer's instructions. All leakage resulting in pressure loss greater than 10 psi (0.7 bar) per week should be repaired.

4-8.2.5 The dry-pipe valve enclosure should be maintained at a minimum temperature of 40°F (4°C).

4-8.2.6 Before and during freezing weather, all low-point drains on dry-pipe systems should be drained as frequently as required to remove all moisture. This process should be repeated daily until all condensate has been removed. The freezing of a small amount of water in the system piping may cause rupture of the sprinkler system

resulting in extensive damage to the sprinkler system and water damage to the building and contents. Drum drip assemblies should be in a warm area or in a heated enclosure, when practical.

4-8.3 Trip Tests.

4-8.3.1 Trip tests of each dry-pipe valve, including quick-opening devices, if any, should be done in the spring to allow all condensate to drain from the system piping. At this time, thoroughly clean the dry-pipe valve, renew parts as required and reset the valve.

4-8.3.2 Each dry-pipe valve should be trip tested with control valve partially open, cleaned and reset at least once each year during warm weather. The shut-off valve should be kept open at least far enough to permit full flow of water at good pressure through the main drain when it is fully opened.

4-8.3.3 Before any dry-pipe valve is tripped or tested, the water supply line to it should be thoroughly flushed. The main drain below the valve should be opened wide, and water at full pressure should be discharged long enough to clear the pipe of any accumulation of scale or foreign material. If there is a hydrant on the supply line, this hydrant should be flushed before the main drain is opened.

4-8.3.4 **Caution:** The tripping of dry-pipe valves with throttled water supplies will not completely operate some models that require a high rate of flow to complete movement of the clapper assemblies.

4-8.3.5 All dry-pipe valves should have a tag or card attached showing the date on which the valve was last tripped and showing the name of the person and the organization making the test. Separate records of initial air and water pressures, tripping time and tripping air pressure, and dry-pipe valve operating condition should be kept for comparison with previous test records.

4-8.4 **Trip Test Full Flow.** Each dry-pipe valve should be trip tested with control valve wide open at least once every three years or when the system is altered. This test should be conducted by opening the inspector's test pipe. Test should be terminated when the dry-pipe valve has tripped and clean water is flowing at the inspector's test pipe.

4-9 Air Compressor.

4-9.1 An air compressor should be lubricated only if recommended by the manufacturer and in accordance with his instructions. The motor unit should be kept dirt free. Filters and strainers should be cleaned as required. Crystals in air dryers should be replaced when color changes indicate they have absorbed moisture.

4-10 Air Maintenance Device.

4-10.1 Strainers, filters and restriction orifices should be cleaned as required. If regulator is provided with a drain cock, periodically remove condensation.

4-11 Quick-Opening Devices (Accelerator or Exhauster).

4-11.1 The quick-opening device should be tested at least twice a year.

The manufacturer's instructions for testing and resetting the device should be carefully followed. When the device does not operate properly on test, the dry-pipe system should be kept in service and the device repaired or replaced immediately. Repair parts or replacement device should be obtained from the original manufacturer.

4-12 Deluge, Preaction and Automatic On-Off Preaction Systems.

4-12.1 Complete charts are furnished by the installing company, showing the proper method of operating and testing these systems. Only competent mechanics fully instructed with respect to the details and operation of such systems should be employed in their repair and adjustment. It is highly advisable for the owner to arrange with the installing company for at least annual inspection and testing of the equipment.

4-12.2 In preaction systems when it is necessary to repair the actuating system, as distinguished from the piping system itself, the water may be turned into the sprinkler piping, and automatic sprinkler protection thus maintained without alarm service, provided there is no danger of freezing.

4-12.3 Test detection systems semi-annually and alarms quarterly according to the procedures suggested by the manufacturer.

Chapter 5 Flushing

5-1 Flushing.

5-1.1 For effective control and extinguishment of fire, automatic sprinklers should receive an unobstructed flow of water. Although the overall performance record of automatic sprinklers has been very satisfactory, there have been numerous instances of impaired efficiency because sprinkler piping or sprinklers were plugged with pipe scale, mud, stones, or other foreign material. If the first sprinklers to open in a fire are plugged, the fire in that area will not be extinguished, an excessive number of sprinklers will operate causing increased water damage, and possibly the fire will spread out of control.

5-2 Types of Obstruction Material.

5-2.1 Obstructions may consist of compacted fine materials, such as rust, mud, or sand. Pipe scale is found more frequently in dry-pipe than in wet systems. Dry-pipe systems that have been maintained wet or dry alternately over a period of years are particularly susceptible to the accumulation of scale. Also, in systems continuously dry, condensation of moisture in the air supply may result in the formation of a hard scale along the bottom of the piping. When sprinklers open, the scale is broken loose and

carried along the pipe, plugging some of the sprinklers or forming obstructions at the fittings.

5-2.2 Stones of various sizes, cinders, cast-iron pipe tubercles, chips of wood, or other coarse materials may be found. Sprinkler piping is sometimes partially obstructed by such objects as pieces of wood, paint brushes, broken pump valves or springs, or excess materials from improperly poured pipe joints. Materials may be sucked from the bottom of streams or reservoirs by fire pumps with poorly arranged or inadequately screened intakes and forced into the system. Sometimes floods damage intakes. Other materials may be permitted to enter by careless workers during installation or extensions of mains.

5-3 Preventing Entrance of Obstructive Material. The following measures should be taken to assure, as far as possible, that sprinkler systems are clear of obstructive foreign matter and will remain unobstructed.

5-3.1 Take care when installing underground mains, both public and private, to prevent entrance of stones, soil, or other foreign material. As assurance that such material has not entered newly installed sprinkler systems from underground mains, installers are required as a condition of acceptance to flush all newly installed mains before connecting the inside piping. Private fire service mains should also be flushed after repairs or when breaks have occurred in public mains.

5-3.2 Screen pump suction supplies and maintain screens in good condition. Equip connections from penstocks with strainers or grids, unless the penstock inlets themselves are so equipped.

5-3.3 Keep dry-pipe systems on air the year round, instead of alternately on air or water, to inhibit formation of rust and scale.

5-3.4 Use extreme care when cleaning tanks and open reservoirs to prevent material from entering piping. Materials removed from the interior of gravity tanks during cleaning should not be permitted to enter the discharge pipe.

5-4 Conditions Showing Need for Investigation. Although precautions for preventing entrance of obstructive materials are generally followed at well-maintained premises, evidence based on fire experience and hundreds of flushing investigations shows that some sprinkler systems are obstructed to an extent that would seriously impair their effectiveness during a fire.

5-4.1 Conditions that may indicate the need of investigation include the following:

(a) Defective intake screens for fire pumps taking suction from streams and reservoirs.

(b) Discharge of obstructive material during routine water tests.

(c) Foreign material in fire pumps, in dry-pipe valves, or in check valves.

(d) Heavy discoloration of water during drain tests or plugging of inspector's test connections.

- (e) Plugging of sprinklers.
- (f) Plugged piping in sprinkler systems dismantled during building alterations.
- (g) Failure to flush underground mains following installations or repairs.
- (h) A record of broken public mains in the vicinity.
- (i) Abnormally frequent tripping of dry-pipe valve.

5-4.2 Sprinkler systems should be examined internally at periodic intervals for obstructions. Where unfavorable conditions such as those itemized above are found, the system should be examined at five-year intervals after installation or possibly sooner. Where conditions are favorable, dry-pipe systems should be examined at ten-year intervals after installation.

5-4.3 Dry-pipe systems found obstructed should be flushed and re-examined at intervals of not more than five years.

5-5 Precautions. When sprinkler systems are to be shut off for investigation or for flushing, take all the precautions outlined earlier. To prevent accidental water damage, control valves should be shut tight and the system completely drained before sprinkler fittings are removed or pipes disconnected. Cover stock and machinery susceptible to water damage, and provide equipment for mopping up any accidental discharge of water.

5-5.1 Large quantities of water are required for effective flushing by the hydraulic method, and it is important to plan in advance the most convenient methods of disposal.

5-6 Investigation Procedure.

5-6.1 From the plan of the fire protection system, determine the sources of water supply, age of mains and sprinkler systems, types of systems, and general piping arrangement.

5-6.2 Examine the fire pump suction supply and screening arrangements. If needed, have the suction cleaned before using the pump in tests and flushing operations. Gravity tanks should be inspected internally, except steel tanks recently cleaned and painted. If possible, have the tank drained and determine whether there is loose scale on the shell or sludge or other obstruction on the tank bottom. Cleaning and repainting may be required, particularly if not done within five years.

5-7 Test — Flushing Mains.

5-7.1 Use hydrants near the ends of mains for flow tests to determine whether mains contain obstructive material. If such material is found, mains should be thoroughly flushed before investigating sprinkler systems. Connect two lengths of 2½-in. hose to the hydrant. Attach burlap bags to free ends of the hose from which the nozzles have been removed to collect any material flushed out, and flow water long enough to determine condition of the main being investigated. If there are several sources of water supply, investigate each independently avoiding any unnecessary interruptions to sprinkler protection. On extensive layouts repeat the tests at several hydrants to determine general conditions.

5-8 Testing Sprinkler Systems.

5-8.1 Investigate the dry systems first. Tests on several carefully selected, representative systems usually are sufficient to indicate general conditions throughout the premises. When preliminary investigations indicate considerable obstructive material, this would justify investigating all systems (both wet and dry) before outlining needed flushing operations.

5-8.2 In selecting specific systems or pipes for investigation, consider:

- (a) Pipes found obstructed during a fire or during maintenance work
- (b) Systems adjacent to points of recent repair to yard mains, particularly if hydrant flow shows material in the main
- (c) Pipes involving long horizontal runs of feed and cross mains. Obstructions are most likely to be found in the most remote branch lines at the end of the longest cross main from the longest feed main, particularly if the branch lines are lower than part of the feed main, as under a deck or platform.

5-8.3 Tests should include flows through 2½-in. fire hose directly from cross mains [see Figures 5-8.3(a) and 5-8.3(b)] and flows through 1½-in. hose from representative branch lines.

5-8.4 The fire pump should be operated for the large volume flows, as maximum pressure is desirable. Burlap bags should be used to collect dislodged material as is done in the investigation of yard mains, and each flow should be continued long enough to show the condition of the piping interior. After a test, leave all valves open and locked or sealed.

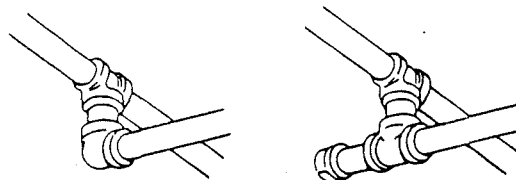

Figure 5-8.3(a) Replacement of elbow at end of cross main with a flushing connection consisting of a 2-in. nipple and cap.

5-9 Dry-Pipe Systems.

5-9.1 Having selected the test points of a dry-pipe system, close the main control valve and release air from the system. Check the piping visually with a flashlight while it is being dismantled. Attach hose valves and 1½-in. hose to ends of branch lines to be tested, shut these valves, and have air pressure restored on the system and the control valve reopened. Open the hose valve on the end branch line allowing the system to trip in simulation of normal action. If this test plugs the hose or piping, the extent of plugging should be noted and cleared from the branch line before proceeding with further tests.

5-9.2 After flowing the small end line, shut its hose valve and test the feed or cross main by discharging water through a 2½-in. fire hose, collecting any foreign material in a burlap bag.

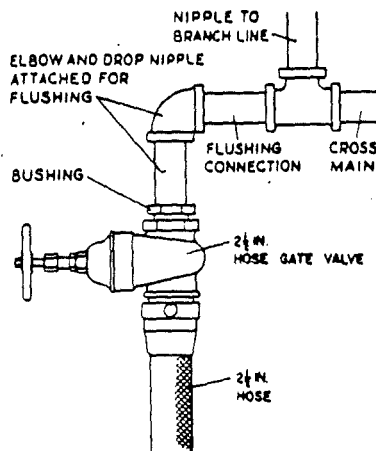

Figure 5-8.3(b) Connection of 2 1/2-in. hose gate valve with 2-in. bushing, and nipple and elbow to 2-in. cross main.

5-9.3 After the test, the dry-pipe valve should be internally cleaned and reset in the normal manner. Its control valve should be opened, sealed and a drain test made.

5-10 Wet Systems.

5-10.1 Testing of wet systems is similar to that of dry systems except that the system must be drained after closing the control valve to permit installation of hose valves for the test. Slowly reopen the control valve and make a small hose flow as prescribed for the branch line, followed by the 2 1/2-in. hose flow for the cross main.

5-10.2 In any case, if lines become plugged during the tests, piping must be dismantled and cleaned, the extent of plugging noted, and a clear flow obtained from the branch line before proceeding further.

5-10.3 Make similar tests on representative systems to indicate the general condition of the wet systems throughout the installation, keeping a detailed record of what is done.

5-11 Outside Sprinklers for Protection Against Exposure Fires.

5-11.1 Outside or open sprinkler equipment should be flow tested once each year during warm weather. Before making flow tests, proper precautions should be taken to prevent damage from water discharge. Flow tests will determine that the sprinklers and the system piping are in good condition and free of obstructions. Obstructed sprinklers or piping should be cleared immediately.

5-12 Flushing Procedure.

5-12.1 If investigation indicates the presence of sufficient material to obstruct sprinklers, a complete flushing program should be carried out. The work should be done by qualified competent personnel. The source of the obstructing material should be determined and steps taken to prevent further entrance of such material. This entails such work as inspection and cleaning of pump suction screening facilities or cleaning of private reservoirs. If recently laid public mains appear to be the source of the obstructing material, waterwork authorities should be requested to flush their system. For recommendations

and procedures for cleaning pump suction see NFPA 20, *Standard for the Installation of Centrifugal Fire Pumps*.

5-13 Private Fire Service Mains.

5-13.1 Mains should be thoroughly flushed before flushing any interior piping. Flush piping through hydrants at dead ends of the system or through blowoff valves, allowing the water to run until clear. If the water is supplied from more than one direction or from a looped system, close divisional valves to produce a high velocity flow through each single line. A velocity of at least 6 ft per second (1.8 m/s) is necessary for cleaning the pipe and for lifting foreign material to an aboveground flushing outlet. Use the flow specified in Table 5-13.1 for the size of the main under investigation.

5-13.2 Connections from main to sprinkler riser should be flushed. Although flow through a short open-ended 2-in. drain may create sufficient velocity in a 6-in. main to move small obstructing material, the restricted waterway of the globe valve usually found on a sprinkler drain may not allow stones and other large objects to pass. If presence of large size material is suspected, a larger outlet will be needed to pass such material and to create the 750-gpm (2839-L/min) flow necessary to move it. Fire department connections on sprinkler risers can be used as flushing outlets by removing the clappers. Mains can also be flushed through a temporary siamese fitting attached to the riser connection before the sprinkler system is installed (see Figure 5-13.2).

Table 5-13.1 Waterflow Recommended for Flushing Piping

Size of Pipe	Flow	
	gpm	(L/min)
4	400	(1514)
6	750	(2839)
8	1000	(3785)
10	1500	(5678)
12	2000	(7570)

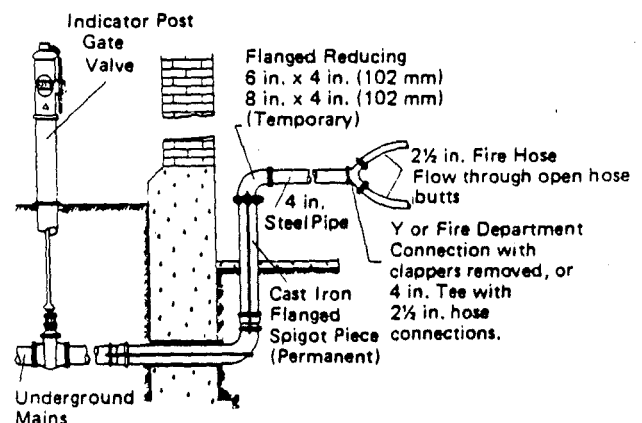

Figure 5-13.2 Arrangement for flushing branches from underground mains to sprinkler risers.

5-13.3 Sprinkler Piping.

5-13.3.1 Two methods are commonly used for flushing sprinkler piping: (a) the hydraulic method and (b) the hypodermic method.

(a) The hydraulic method consists of flowing water progressively from the mains, sprinkler risers, feed mains, cross mains, and finally the branch lines in the same direction in which it would flow during a fire.

(b) The hydropneumatic method utilizes special equipment and compressed air to blow a charge of approximately 30 gal (114 L) of water from the ends of branch lines back into feed mains and down the riser, washing the foreign material out of an opening at the base of the riser.

5-13.3.2 The choice of method depends on conditions at the individual premises. If examination indicates the presence of loose sand, mud, or moderate amounts of pipe scale, the piping can generally be satisfactorily flushed by the hydraulic method. Where the material is more difficult to remove and available water pressures are too low for effective scouring action, the hydropneumatic method is generally more satisfactory.

5-13.3.3 In some cases, where obstructive material is solidly packed or adheres tightly to the walls of the piping, the pipe will have to be dismantled and cleaned by rodding or other positive means.

5-13.3.4 Successful flushing by either the hydraulic or hydropneumatic method is dependent on establishing sufficient velocity of flow in the respective pipes to remove silt, scale, and other obstructive material. With the hydropneumatic method, this is accomplished by the air pressure behind the charge of water.

5-13.3.5 When flushing a branch line through the end pipe, sufficient water should be discharged to scour the largest pipe in the branch line. Lower rates of flow may reduce the efficiency of the flushing operation. To establish the recommended flow, remove small end piping and connect hose to larger section, if necessary.

5-13.3.6 To determine that the piping is clear after it has been flushed, representative branch lines and cross mains should be investigated, using both visual examination and sample flushings.

5-13.3.7 Whenever any section of piping is found severely or completely obstructed with packed material, such as hard scale, cinders, or gravel, the piping will usually have to be disassembled to remove the material.

5-13.3.8 Where pipe scale indicates internal or external corrosion, a section of the pipe affected should be thoroughly cleaned to determine if the walls of the pipe have seriously weakened.

5-13.4 Hydraulic Method. After the mains have been thoroughly cleared, flush risers, feed mains, cross mains, and finally the branch lines. Following this sequence will prevent drawing obstructing material into the interior piping.

5-13.4.1 Water should be turned into dry-pipe systems for one to two days before flushing, if possible, to soften pipe scale and deposits. When alarm is turned off due to this procedure, consideration should be given to providing watch service during the unattended hours. To

flush risers, feed mains, and cross mains, attach 2½-in. hose gate valves to the extreme ends of these lines [see *Figure 5-8.3(b)*.] Such valves usually can be procured from the manifold of fire pumps or hose standpipes. As an alternative, an adapter with 2½-in. hose thread and standard pipe thread can be used with a regular gate valve. A length of fire hose without a nozzle should be attached to the flushing connection. To prevent kinking of the hose and to obtain maximum flow, an elbow should usually be installed between the end of the sprinkler pipe and the hose gate valve. Attach the valve and hose so that no excessive strain will be placed on the threaded pipe and fittings. Support hose lines properly.

5-13.4.2 Where feed and cross mains and risers contain pipe 4, 5, and 6 in. in size, it may be necessary to use a fire department connection with two hose connections to obtain sufficient flow to scour this larger pipe.

5-13.4.3 In multistory buildings, systems should be flushed by starting at the lowest story and working up. Branch line flushing in any story may follow immediately the flushing of feed and cross mains in that story, allowing one story to be completed at a time.

5-13.4.4 Where a repetition of the trouble is probable, leave a 2-in. capped nipple at the ends of the cross mains for flushing piping. Sprinkler installation rules require that a flushing connection be provided at the end of each cross main terminating in 1¼-in. or larger pipe.

5-13.4.5 Flush branch lines after feed and cross mains have been thoroughly cleared. This will avoid drawing obstructing material from these pipes into the branches. Equip the ends of several branch lines with gate valves, and flush individual lines of the group consecutively. This will eliminate the need for shutting off and draining the sprinkler system to change a single hose line. The hose should be 1½ in. and as short as practicable. Branch lines may be flushed in any order that will expedite the work.

5-13.4.6 Branch lines also may be flushed through pipe 1½ in. or larger extending through a convenient window. If pipe is used, 45° elbows should be provided at the ends of branch lines. When flushing branch lines, hammering the pipes is an effective method of moving obstructions.

5-13.4.7 All pendent sprinklers should be removed and cleaned of obstructions.

5-13.4.8 Flushing Gridded Sprinkler Systems. All new gridded sprinkler systems should be arranged so that they can be thoroughly flushed. *Figure 5-13.4.8* should be used as a guide. Other arrangements accomplishing the same results are acceptable.

In the case of a system such as in *Figure 5-13.4.8*, the flushing procedure is as follows:

(a) Disconnect all branch lines close to the secondary cross main, and cap or valve all open ends supplied by the primary cross main. Visually examine the interior of each branch line connected to the secondary cross main and plug or cap.

(b) Flush the primary cross main, first one end, then the other.

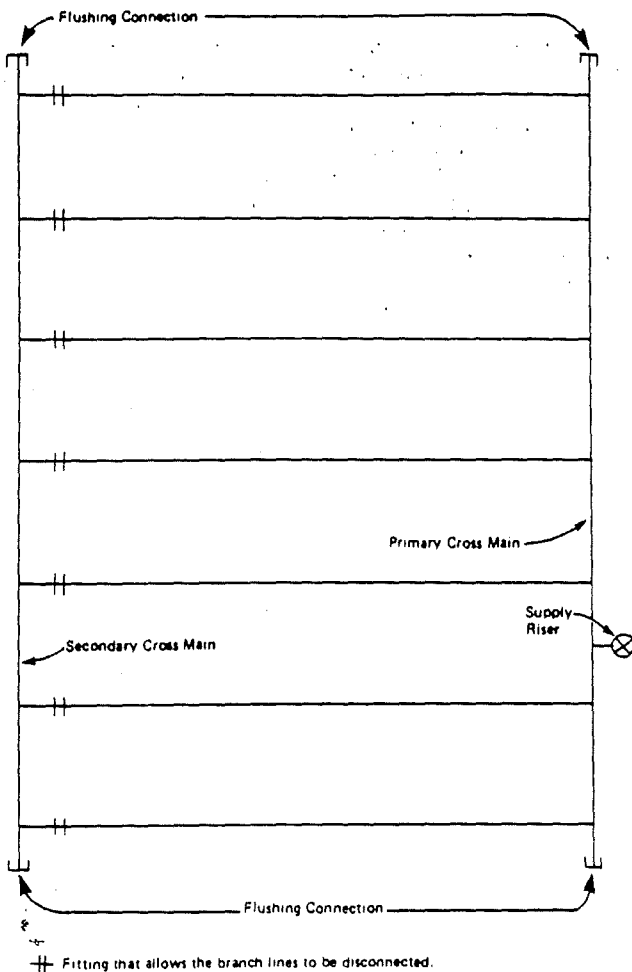

Figure 5-13.4.8.

- (c) Flush each branch line independently.
- (d) Flush the secondary cross main from an auxiliary water source.
- (e) Reconnect branch lines.
- (f) Flush the secondary cross main, first one end, then the other.

5-13.5 Hydropneumatic Method. The apparatus used for hydropneumatic flushing consists of a hydropneumatic machine, a source of compressed air, 1-in. (25-mm) air supply hose, 1½-in. hose for connecting to the sprinkler system, and 2½-in. hose.

5-13.5.1 The hydropneumatic machine (see Figure 5-13.5.1) consists of a 30-gal (114-L) water tank mounted over a 25-cu ft [(185-gal) (700-L)] compressed air tank. The compressed air tank is connected to the top of the water tank through a 2-in. lubricated plug cock. The bottom of the water tank is connected through hose to a suitable water supply. The compressed air tank is connected through suitable air hose to either the plant air system or a separate air compressor.

5-13.5.2 To flush the sprinkler piping, the water tank is filled with water, the pressure raised to 100 psi (6.90 bars)

in the compressed air tank, and the plug cock between tanks opened to put air pressure on the water. The water tank is connected by hose to the sprinkler pipe to be flushed. Then the lubricated plug cock on the discharge outlet at the bottom of the water tank is snapped open, permitting the water to be "blown" through the hose and sprinkler pipe by the compressed air. The water tank and air tank should be recharged after each blow.

5-13.5.3 Outlets for discharging water and obstructing material from the sprinkler system must be arranged. With the clappers of dry-pipe valves and alarm check valves on their seats and cover plates removed, sheet metal fittings can be used for connection to 2½-in. hose lines or for discharge into a drum. [Maximum capacity per blow is about 30 gal (114 L).] If the main riser drain is to be used, the drain valve should be removed and a direct hose connection made. For wet-pipe systems with no alarm check valves, the riser should be taken apart just below the drain opening and a plate inserted to prevent foreign material from dropping to the base of the riser. Where dismantling of a section of the riser for this purpose is impractical, the hydropneumatic method should not be used.

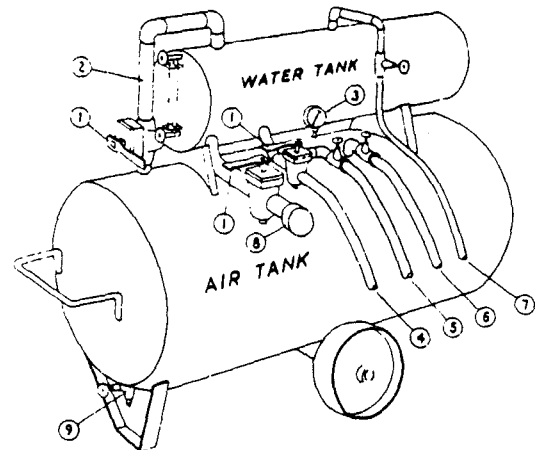

Figure 5-13.5.1 Hydropneumatic Machine.

1. Lubricated plug cocks.
2. Pipe connection between air and water tanks. This connection is open when flushing sprinkler system.
3. Air pressure gage.
4. 1-in. (25-mm) rubber hose (air type). Used to flush sprinkler branch lines.
5. Hose connected to source of water. Used to fill water tank.
6. Hose connected to ample source of compressed air. Used to supply air tank.
7. Water tank overflow hose.
8. 2½-in. pipe connection. When flushing large interior piping, connect woven jacket fire hose here and close 1-in. (25-mm) plug cock hose connection (4) used for flushing sprinkler branch lines.
9. Air tank drain valve.

5-13.5.4 Before starting a flushing job, each sprinkler system to be cleaned should be studied and a schematic plan prepared showing the order of the blows.

5-13.5.5 Hydropneumatic Method of Flushing Branch Lines. With the mains already flushed or known to be

(c) Submit recommendations to management. Consideration should be given to the need for temporary protection, termination of all hazardous operations and frequent inspections of the area involved with 24-hour per day watchman service.

(d) Notify the fire department.

(e) Notify the insurance carrier, the alarm company, and other appropriate authority and implement Tag Impairment System (if such system is in use).

(f) Notify the supervisors in the areas to be affected.

6-3.2 When all impaired equipment is restored to normal working order, the following should be accomplished:

(a) Verify that all control valves are fully opened and locked, sealed, or equipped with a tamper switch.

(b) Conduct a main drain and alarm test on each sprinkler riser affected.

(c) Maintain as large a portion of the system in service as possible.

(d) Advise supervisors that protection has been restored.

(e) Advise the fire department that protection has been restored.

(f) Advise the insurance carrier, the alarm company, and other appropriate authority that protection has been restored.

6-4 Emergency Impairments. Emergency impairments include sprinkler leakage, frozen or ruptured piping, equipment failure, etc. When this occurs, appropriate emergency action should be taken. The Coordinator should be contacted, and he should proceed to the extent possible to implement the preplanned impairment program including the restoration of sprinkler protection.

6-5 Restoring Systems to Service after Disuse.

6-5.1 Occasionally, automatic sprinkler systems in idle or vacant properties are shut off and drained. When the equipment in such properties is restored to service, it is recommended that such work be performed by a responsible and experienced sprinkler contractor. In such cases, the following procedures are recommended:

6-5.1.1 All lines of sprinkler piping should be traced from the extremities of the system to the main connections with a careful check for blank gaskets in flanges, closed valves, corroded or damaged sprinklers or piping, insecure or missing hangers and insufficient support. Proper repairs or adjustments should be made and needed extensions or alterations of the equipment should be completed.

6-5.1.2 Air should be used to test the system for leaks before turning on the water. Water should be admitted slowly to the system, with proper precautions against damage by escape of water from previously undiscovered defects. When the system has been filled under normal service pressure, drain valve tests should be made to detect any closed valve that possibly could have been overlooked. All available test pipes then should be

flushed, and where such pipes are not provided in accordance with the present standards, the proper equipment should be installed.

6-5.1.3 Where the sprinkler system has been long out of service, damaged by freezing or subject to extensive repairs or alterations, the entire system should be hydrostatically tested in accordance with NFPA 13, *Standard for the Installation of Sprinkler Systems*. Special care should be taken to detect any sprinklers showing leaks and to make replacements where necessary.

6-5.1.4 Dry-pipe valves, quick-opening devices, alarm valves and all alarm connections should be examined, put in proper condition and tested. Fire pumps, pressure and gravity tanks, reservoirs and other water supply equipment should receive proper attention before being placed in service. Each supply should be tested separately.

6-5.1.5 An investigation for obstruction or stoppage in the sprinkler system piping should be made. (*See Chapter 5.*)

6-5.1.6 All control valves should be operated from closed to fully open position and should be left sealed, locked or equipped with a tamper switch.

6-6 Sprinkler System Alterations.

6-6.1 Alterations will usually involve an impairment to all or part of the sprinkler system. Any alteration to a sprinkler system should be done in accordance with NFPA 13, *Standard for the Installation of Sprinkler Systems*, or other applicable NFPA standards.

Chapter 7 Fire Records

7-1 Protection Records.

7-1.1 In all businesses, it is desirable to keep records of inspection, testing and maintenance of protection equipment. The exact program for any building or set of buildings should be tailored to a specific plan for the particular building, considering occupancy, types of protection, alarms provided, etc. In the development of a fire protection record plan, it is advisable to consider advice from various sources including the:

Authority Having Jurisdiction (Rating Bureaus, Fire Prevention Bureaus, Fire Marshals, etc.).

Manufacturers of Various Devices

Fire Insurance Companies

Independent Fire Protection Consultants

Sprinkler Contractors

Other Applicable NFPA Codes as outlined in the Appendix.

7-1.2 An individual within the organization should be designated (Protection Record Administrator) to implement inspection, testing and maintenance programs.

Some firms may elect to do the basic functions themselves and contract the more technically involved operations.

7-1.3 The person in charge should consider the use of master control records, including a copy of the manufacturer's instructions covering all devices.

7-2 Valve Tag Systems.

7-2.1 Closed valves have caused over 30 percent of all sprinkler system failures. Adoption of the valve tag systems should visually highlight and minimize this significant cause of unsatisfactory sprinkler system performance. (See Figure 7-2.1.)

7-2.2 Tag Impairment System. This system usually includes a three-part tag which is easily identifiable. One part is tied to a valve to be closed temporarily. The second part is sent to the authority having jurisdiction. The third part is displayed in the protection record administrator's office and sent to the authority having jurisdiction when protection is restored.

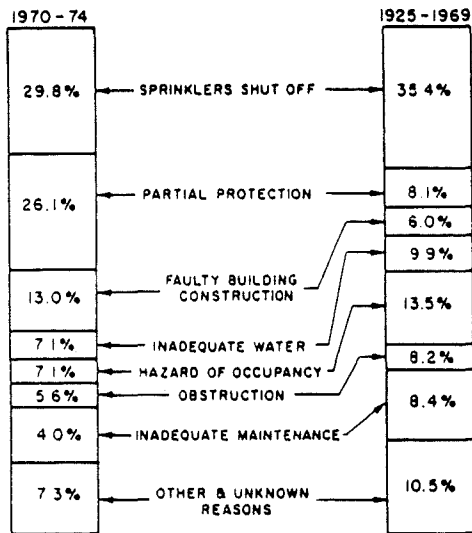

Figure 7-2.1 Reasons for unsatisfactory sprinkler system performance.

7-2.3 Valve Record Tag System. A tag on each valve indicating date sealed or locked, date and results of maintenance procedures should be provided. This provides a chronological record of valve maintenance.

7-3 Inspection Records. Inspection and maintenance records should be kept by the protection record administrator of the following activities:

Table 7-3

Summary: Minimum Inspection - Testing - Maintenance

Records - Inspection = Visual Observation
 Testing = Handling Equipment, etc.
 Maintenance = Periodic Servicing and Repair

For Guidance on Specific Valves, Pumps, Hydrants, etc., Refer to the Manufacturer's Instructions.

Parts	Activity	Frequency	Section Number
Flushing Piping	Test	5 Years 10 Years	5-4.2
Fire Department Connections	Inspection	Monthly	2-8
Indicator Post Valve or Tamper Switch	Inspection Test	Weekly-Sealed Monthly-Locked Quarterly	2-7.1.4 2-7.3.1 2-7.4.1
Main Drain	Flow Test	Quarterly	2-6.1
Open Sprinklers	Test	Annual	5-11.1
Pressure Gage	Calibration Test	5 Years	4-4.2
Sprinklers	Test	50 Years	3-3.3
Sprinklers-High Temp.	Test	5 Years	3-3.1
Valves in Roadway Boxes	Inspection Test	Weekly-Sealed Monthly-Locked Quarterly	2-7.1.4 2-7.3.1 2-7.4.1
Valves on Systems	Inspection Inspection Maintenance	Weekly-Sealed Monthly-Locked Yearly	2-7.1.4 2-7.1.4 2-7.1.8
Water Flow Alarms	Inspection	Monthly	4-12.3
Hydrants	Inspection Test (Open and Close)	Monthly Semi-Annually	2-5.1 2-5.3
	Maintenance		2-5.2
Antifreeze Solution	Test	Annually	4-7.3
Cold Weather Valves	Open and Close	Fall, Close; Spring, Open	4-7.2
Dry-Pipe Valve	Air Pressure Water Pressure	Inspection Inspection	Weekly Daily-Cold Weather
Enclosure	Inspection	Quarterly	Chapter 4 4-8.2.5
Priming Water Level	Inspection	Quarterly	4-8.2.8
Dry-Pipe Valves	Trip Test	Annual-Spring	1-6.1 4-8.3.1
Dry-Pipe Valves	Full Flow Trip Test	3 Years-Spring	4-8.4
Low Point Drains	Test	Fall	4-8.2.8
Quick-Opening Devices	Test	Semi-Annually	4-11.1
Gravity Tank	Water Level	Inspection	Monthly
Heat	Inspection	Daily-Cold Weather	2-2.1 2-2.2
Condition	Inspection	Bi-Annual	2-2.6
Pressure Tank	Water Level & Pressure	Inspection	Monthly
Heat Enclosures	Inspection	Daily-Cold Weather	2-3.1 2-3.7
Condition	Inspection	3 Years	2-3.2
Pump Centrifugal	Test-Operate	Weekly	2-4.2.2
	Test-Reduced	Weekly	2-4.2.2
	Water	Pressure Start	Weekly
	Test-Capacity	Yearly	2-4.2.2 2-4.2.5
Steam Pump	Test Operate	Yearly	2-4.2.4
	Test Capacity	Yearly	2-4.2.5

Exhibit I Report of Inspection

Owner's Section (To be answered by Owner or Occupant)

- A. Explain any occupancy hazard changes since the previous inspection.
- B. Describe fire protection modifications made since last inspection.
- C. Describe any fires since last inspection.
- D. When was the system piping last checked for stoppage, corrosion or foreign material?
- E. When was the dry-piping system last checked for proper pitch?
- F. Are dry valves adequately protected from freezing?

Inspector's Section (All responses reference current inspection)

- 1. General
 - a. Is the building occupied?
 - b. Are all systems in service?
 - c. Is there a minimum of 18 in. (457 mm) clearance between the top of the storage and the sprinkler deflector?
 - d. In areas protected by wet system, does the building appear to be properly heated in all areas, including blind attics and perimeter areas, where accessible? Do all exterior openings appear to be protected against freezing?
 - e. Does the hand hose on the sprinkler system appear to be satisfactory?
- 2. Control Valves (See Item 14.)
 - a. Are all sprinkler system control valves and all other valves in the appropriate open or closed position?
 - b. Are all control valves in the open position and locked, sealed or equipped with a tamper switch?
- 3. Water Supplies (See Item 15.)
 - a. Was a water flow test of main drain made at the sprinkler riser?
- 4. Tanks, Pumps, Fire Department Connections
 - a. Are fire pumps, gravity tanks, reservoirs and pressure tanks in good condition and properly maintained?
 - b. Are fire department connections in satisfactory condition, couplings free, caps in place, and check valves tight? Are they accessible and visible?
- 5. Wet Systems (See Item 13.)
 - a. Are cold weather valves (O.S.&Y.) in the appropriate open or closed position?
 - b. Have antifreeze system solutions been tested?
 - c. Were the antifreeze test results satisfactory?

- 6. Dry Systems (See Items 10 to 14.)
 - a. Is the dry valve in service?
 - b. Are the air pressure and priming water level in accordance with the manufacturer's instructions?
 - c. Has the operation of the air or nitrogen supply been tested? Is it in service?
 - d. Were low points drained during this inspection?
 - e. Did quick-opening devices operate satisfactorily?
 - f. Did the dry valve trip properly during the trip pressure test?
 - g. Did the heating equipment in the dry-pipe valve room operate at the time of inspection?
- 7. Special Systems — as defined in Section 1-3 (See Item 16.)
 - a. Did the deluge or pre-action valves operate properly during testing?
 - b. Did the heat-responsive devices operate properly during testing?
 - c. Did the supervisory devices operate during testing?
- 8. Alarms
 - a. Did water motor and gong test satisfactorily?
 - b. Did electric alarm test satisfactorily?
 - c. Did supervisory alarm service test satisfactorily?
- 9. Sprinklers
 - a. Are all sprinklers free from corrosion, loading or obstruction to spray discharge?
 - b. Are sprinklers over 50 years old, thus requiring sample testing?
 - c. Is stock of spare sprinklers available?
 - d. Does the exterior condition of sprinkler system appear to be satisfactory?
 - e. Temperature. Are sprinklers of proper temperature ratings for their locations?
- 10. Date dry-pipe valve trip tested (control valve partially open) _____ (See Trip Test Table which follows.)
- 11. Date dry-pipe valve trip tested (control valve fully open) _____ (See Trip Test Table which follows.)
- 12. Date quick-opening device tested _____ (See Trip Test Table which follows.)
- 13. Date deluge or preaction valve tested _____ (See Trip Test Table which follows.)

Trip Test Table

DRY PIPE OPERATING TEST	DRY VALVE				O.D.D.				
	MAKE		MODEL	SERIAL NO.	MAKE		MODEL	SERIAL NO.	
	TIME TO TRIP THRU TEST PIPE		WATER PRESSURE	AIR PRESSURE	TRIP POINT AIR PRESSURE	TIME WATER REACHED TEST OUTLET	ALARM OPERATED PROPERLY		
	MIN.	SEC.	PSI	PSI	PSI	MIN.	SEC.	YES	NO
Minimum G.O.D.									
Maximum G.O.D.									
IF NO, EXPLAIN _____									
OPERATION <input type="checkbox"/> PNEUMATIC <input type="checkbox"/> ELECTRIC <input type="checkbox"/> HYDRAULIC									
PIPING SUPERVISED <input type="checkbox"/> YES <input type="checkbox"/> NO DETECTING MEDIA SUPERVISED <input type="checkbox"/> YES <input type="checkbox"/> NO									
CODE VALVE OPERATE FROM THE MANUAL TRIP AND/OR REMOTE CONTROL STATIONS <input type="checkbox"/> YES <input type="checkbox"/> NO									
IS THERE AN ACCESSIBLE FACILITY IN EACH CIRCUIT FOR TESTING IF NO, EXPLAIN _____									
IS THERE AN ACCESSIBLE FACILITY IN EACH CIRCUIT FOR TESTING <input type="checkbox"/> YES <input type="checkbox"/> NO									
DOES EACH CIRCUIT OPERATE UNDER SUPERVISION <input type="checkbox"/> YES <input type="checkbox"/> NO									
DOES EACH CIRCUIT OPERATE UNDER VALVE RELEASE <input type="checkbox"/> YES <input type="checkbox"/> NO									
MAXIMUM TIME TO OPERATE RELEASE									
MAKE MODEL									
MIN. SEC.									

14. See Control Valve Maintenance Table.

Control Valve Maintenance Table

Control Valves	Number	Type	Open	Secured	Closed	Signs	Condition	Explain
								Abnormal
City Connection Control Valve								
Tank Control Valves								
Pump Control Valves								
Sectional Control Valves								
System Control Valves								
Other Control Valves								

15. Water Flow Test at Sprinkler Riser

Water Supply Source		City	Tank	Pump
Date	Test Pipe Location	Size Test Pipe	Static Pressure	Residual (Flow) Pressure
Last Water Flow Test				
This Water Flow Test				

16. Heat Responsive Devices

Test Method _____

Type of Equipment _____

Manufacturer _____

Test Results:

Valve No.	A	B	C	D	E	F	Valve No.	A	B	C	D	E	F
Valve No.	A	B	C	D	E	F	Valve No.	A	B	C	D	E	F
Valve No.	A	B	C	D	E	F	Valve No.	A	B	C	D	E	F
Valve No.	A	B	C	D	E	F	Valve No.	A	B	C	D	E	F

Auxiliary Equipment: No.? _____ Type? _____ Location? _____ Test Result? _____

17. Explain any "No" answers and comments. _____

18. Adjustments or corrections made during this inspection: _____

19. Although these comments are not the result of an engineering review, the following desirable improvements are recommended:

Signature: _____
 Date: _____

Appendix

This Appendix is not a part of this NFPA document, but is included for information purposes only.

A-1 Referenced Publications.

A-1-1 NFPA Publications. This publication makes reference to the following NFPA documents and the year dates shown indicate the latest edition. They are available from the National Fire Protection Association, Batterymarch Park, Quincy, MA 02269.

NFPA 13-1980, *Standard for the Installation of Sprinkler Systems*

NFPA 13E-1978, *Recommendations for Fire Department Operations in Properties Protected by Sprinkler and Standpipe Systems*

NFPA 20-1980, *Standard for the Installation of Centrifugal Fire Pumps.*

NFPA 21-1975, *Standard for the Operation and Maintenance of National Standard Steam Fire Pumps*

NFPA 22-1981, *Standard for Water Tanks for Private Fire Protection*

NFPA 24-1981, *Standard for Private Fire Service Mains and Their Appurtenances*

NFPA 26-1976, *Recommended Practices for the Supervision of Valves Controlling Water Supplies for Fire Protection*

NFPA 33-1977, *Standard for Spray Application Using Flammable and Combustible Materials*

NFPA 231D-1980, *Standard for Storage of Rubber Tires*

NFPA 1962-1979, *Standard for the Care, Maintenance and Use of Fire Hose Including Connections and Nozzles*

A-2 Other Publications.

A-2-1 A selected list of other NFPA publications related to the inspection, testing and maintenance of sprinkler systems is as follows:

NFPA 14-1980, *Standard for the Installation of Standpipe and Hose Systems*

NFPA 71-1977, *Standard for the Installation, Maintenance and Use of Central Station Signaling Systems*

NFPA 72A-1979, *Standard for the Installation, Maintenance, and Use of Local Protective Signaling Systems*

NFPA 72B-1979, *Standard for the Installation, Maintenance and Use of Auxiliary Protective Signaling Systems*

NFPA 87-1980, *Standard for the Construction and Protection of Piers and Wharves*

NFPA 231-1980, *Standard for Indoor General Storage*

NFPA 231C-1980, *Standard for Rack Storage of Materials*

NFPA 231D-1980, *Standard for the Storage of Rubber Tires*

A-2-2 Other Codes and Standards. This publication makes reference to the following codes and standards.

No. 13-C, *Recommended Method of Reporting Dry Pipe Valve Tests*, available from the American Insurance Association Engineering and Safety Department, 85 John Street, New York, NY 10038.

ASME, *Non-Fired Pressure Vessel Code*, available from the American Society of Mechanical Engineers, East 47th Street, New York, NY 10017.

ASTM E380-1976, *Standard for Metric Practice*, available from the American Society for Testing and Materials, 1916 Race Street, Philadelphia, PA 19103.

A14.125 STANDPIPE SYSTEMS. The following is a reprint of NFPA No. 14,
Ch. 8:

Chapter 8 Tests and Inspection

8-1 Tests.

8-1.1* All new systems including yard piping shall be tested hydrostatically at not less than 200 lb psi (13.8 bars) pressure for 2 hr, or at 50 psi (3.5 bars) in excess of the normal pressure when the normal pressure is in excess of 150 psi (10.3 bars). The hydrostatic test pressure shall be measured at the low elevation point of the individual system or zone being tested. The inside standpipe piping shall show no leakage.

8-1.2* A flow test shall be conducted at the hydraulically most remote outlet to assure the requirements of 5-3.2 are met.

8-1.3 Piping between the fire department connection and the check valve in the inlet pipe shall be tested hydrostatically in the same manner as the balance of the system.

8-1.3.1 Piping between the fire department connection and the check valve in the inlet pipe shall be flushed with a sufficient volume of water so as to remove all construction debris and trash which may have accumulated in this pipe prior to the completion of the system and prior to the installation of the fire department connection.

8-1.4 In a standpipe system any piping which normally remains dry shall be hydrostatically tested at 50 psi (3.4 bars) above the normal pressure at intervals of not less than 5 years.

8-1.5* Before it is restored to service and before water is turned into it, a standpipe system which has been out of service a number of years shall be tested with air at a pressure not exceeding 25 psi (1.7 bars) to determine its tightness. The standpipe system shall also be hydrostatically tested at 50 psi (3.4 bars) above the normal pressure.

8-2 Periodic Inspection.

8-2.1 Systematic periodic inspections of all portions of the standpipe system are essential, and personnel to whom this duty is entrusted shall be held strictly responsible for its condition.

8-2.2* The tanks shall be kept properly filled, and where pressure tanks are employed, a pressure of at least 75 psi (5.2 bars) shall be maintained at all times. Special attention shall be given to the condition of the tanks during freezing weather.

8-2.3* The valves in the main connection to the automatic sources of water supply shall be open at all times. The hose valves shall be frequently examined to see that they are tight.

8-2.4 Inspections shall be made frequently to assure that the hose on Class II and Class III systems is in proper position on the racks, and that all of the equipment is in place and in good condition. The hose, including gaskets, shall be removed and inspected and the hose re-racked or reeled at intervals in accordance with NFPA 1962, *Standard for the Care, Use and Maintenance of Fire Hose Including Connections and Nozzles*. Where couplings are polished, care shall be taken to see that polish used does not touch fabric of hose.

8-2.5 When a standpipe system or any portion thereof is out of service for any reason, notice shall be given to the local fire department and a sign shall be posted on each fire department connection indicating what portion of the system is out of service.

A14.126 MANUAL FIRE ALARM SYSTEMS. The following is a reprint of NFPA
No. 72A:

NFPA 72A

**Standard for the
Installation, Maintenance and Use of
Local Protective Signaling Systems
for Guard's Tour, Fire Alarm and
Supervisory Service**

1985 Edition

NOTICE: An asterisk (*) following the number or letter designating a paragraph indicates explanatory material on that paragraph in Appendix A.

Information on referenced publications can be found in Chapter 4 and Appendix B.

Chapter 1 General

1-1 Scope.

1-1.1 The provisions of this standard contemplate supervised systems providing fire alarm or supervisory signals within the protected premises. These systems are primarily for the protection of life by indicating the necessity for evacuation of the building and secondarily for the protection of property.

1-1.2 The intent and meaning of the terms used in this standard are, unless otherwise defined herein, the same as those of NFPA 70, *National Electrical Code*[®].

1-1.3 The energy sources for operation of the system may be an electric power source connected to the devices through electrical circuits, or may consist of suitable tanks of compressed or liquefied gas connected through tubing or piping.

1-1.4 The systems shall provide for one or more of the following:

- (a) Manual fire alarm service.
- (b) Automatic fire alarm service.
- (c) Automatic detection of alarm or abnormal conditions in extinguishing systems, such as sprinkler and carbon dioxide.
- (d) Guard's tour supervisory service.
- (e) Automatic detection of abnormal conditions in industrial processes which could result in fire or explosion endangering life or property.
- (f) Use of all or part of electrical-type systems for additional purposes, such as (1) sounding of paging signals throughout the premises, (2) distribution of music throughout the premises.
- (g) Addition of such items as in item f as are applicable to gas-operated systems.

NOTE: Systems under items (f) and (g) shall be known as combination systems.

1-1.5 Depending upon the application, local fire alarm systems shall be permitted to include the feature of

locating the point of origin of the alarm by coded alarm signals or annunciation.

1-1.6 A device or system having materials or forms different from those detailed in this standard may be examined and tested according to the intent of the standard and, if found equivalent, may be approved.

1-2 Approval and Acceptance.

1-2.1 The authority having jurisdiction shall be notified prior to installation or alteration of equipment or wiring. At its request, complete information regarding the system or system alterations, including specifications, wiring diagrams, and floor plans, shall be submitted for approval.

1-2.2 Equipment. All devices, combinations of devices, appliance and equipment installed in conformity with this standard shall be listed for the protective signaling purpose for which they are used.

1-2.2.1 Voltage, Temperature and Humidity Variation. Equipment shall be so designed that it shall be capable of performing its intended function under the following conditions:

- (a) At 85 percent and at 110 percent of the nameplate primary (main) and secondary (standby) input voltage(s),
- (b) At ambient temperatures of $32^{\circ} \pm 4^{\circ}\text{F}$ ($0^{\circ} \pm 2^{\circ}\text{C}$) and $120^{\circ} \pm 4^{\circ}\text{F}$ ($49^{\circ} \pm 2^{\circ}\text{C}$), for a minimum duration at each extreme of 3 hours,
- (c) At a relative humidity of 85 ± 5 percent and an ambient temperature of $90^{\circ} \pm 4^{\circ}\text{F}$ ($32^{\circ} \pm 2^{\circ}\text{C}$), for a duration of at least 24 hours.

1-2.3 Acceptance Tests. Upon completion of an installation or alterations, satisfactory tests of the entire system shall be made in the presence of a representative of the authority having jurisdiction. All functions of the system shall be tested, including operation of the system in various alarm and trouble modes for which it is designed (e. g., open circuit, grounded circuit, power outage, etc.).

1-2.4 Maintenance and Testing. All systems shall be under the supervision of qualified persons. These persons shall cause proper tests and inspections to be made at prescribed intervals. The authority having jurisdiction shall be consulted on all alterations and additions to the system under its supervision.

1-2.4.1 The owner shall provide for proper maintenance of the system. A maintenance agreement with specialists acceptable to the authority having jurisdiction may be used in lieu of developing staff specialists.

1-3 Definitions. Unless expressly stated elsewhere, the following terms will, for the purpose of this standard, have the meanings indicated below.

Alarm Service. The service required following the receipt of an alarm signal.

Alarm Signal. A signal indicating an emergency requiring immediate action, as an alarm for fire from a

manual box, a water flow alarm, an alarm from an automatic fire alarm system, or other emergency signal.

Annunciator. A unit containing two or more identified targets or indicator lamps in which each target or lamp indicates the circuit, condition, or location to be annunciated.

Approved. Acceptable to the "authority having jurisdiction."

NOTE: The National Fire Protection Association does not approve, inspect or certify any installations, procedures, equipment, or materials nor does it approve or evaluate testing laboratories. In determining the acceptability of installations or procedures, equipment or materials, the authority having jurisdiction may base acceptance on compliance with NFPA or other appropriate standards. In the absence of such standards, said authority may require evidence of proper installation, procedure or use. The authority having jurisdiction may also refer to the listings or labeling practices of an organization concerned with product evaluations which is in a position to determine compliance with appropriate standards for the current production of listed items.

Authority Having Jurisdiction. The "authority having jurisdiction" is the organization, office or individual responsible for "approving" equipment, an installation or a procedure.

NOTE: The phrase "authority having jurisdiction" is used in NFPA documents in a broad manner since jurisdictions and "approval" agencies vary as do their responsibilities. Where public safety is primary, the "authority having jurisdiction" may be a federal, state, local or other regional department or individual such as a fire chief, fire marshal, chief of a fire prevention bureau, labor department, health department, building official, electrical inspector, or others having statutory authority. For insurance purposes, an insurance inspection department, rating bureau, or other insurance company representative may be the "authority having jurisdiction." In many circumstances the property owner or his designated agent assumes the role of the "authority having jurisdiction"; at government installations, the commanding officer or departmental official may be the "authority having jurisdiction."

Combination System. A local protective signaling system for fire alarm, supervisory or guard's tour supervisory service whose components may be used in whole or in part in common with a nonfire signaling system, such as a paging system, a burglar alarm system, a musical program system, or a process monitoring service system, without degradation of or hazard to the protective signaling system.

Gas-Operated (Local Fire Alarm) System. A local fire alarm system employing a compressed or liquefied gas as the energy to be released to sound audible signals when an alarm is transmitted.

Labeled. Equipment or materials to which has been attached a label, symbol or other identifying mark of an organization acceptable to the "authority having jurisdiction" and concerned with product evaluation, that maintains periodic inspection of production of labeled equipment or materials and by whose labeling the manufacturer indicates compliance with appropriate standards or performance in a specified manner.

Listed. Equipment or materials included in a list published by an organization acceptable to the "authority having jurisdiction" and concerned with product evaluation,

that maintains periodic inspection of production of listed equipment or materials and whose listing states either that the equipment or material meets appropriate standards or has been tested and found suitable for use in a specified manner.

NOTE: The means for identifying listed equipment may vary for each organization concerned with product evaluation, some of which do not recognize equipment as listed unless it is also labeled. The "authority having jurisdiction" should utilize the system employed by the listing organization to identify a listed product.

Local Alarm System. A local system sounding an alarm as the result of the manual operation of a fire alarm box or the operation of protection equipment or systems, such as water flowing in a sprinkler system, the discharge of carbon dioxide, the detection of smoke or the detection of heat.

Local Supervisory System. A local system arranged to supervise the performance of guard's tours, or the operative condition of automatic sprinkler systems or other systems for the protection of life and property against the fire hazard.

Local System. A local system is one which produces a signal at the premises protected.

Maintenance. Repair service, including periodically recurrent inspections and tests, required to keep the protective signaling system and its component parts in an operative condition at all times, together with replacement of the system or of its components, when for any reason they become undependable or inoperative.

Musical Program System. A system transmitting musical programs over loudspeakers for entertainment purposes, the programs originating either on the premises or at a remote point and transmitted to the premises.

Paging System. A system intended to page one or more persons such as by means of voice over loudspeaker stations located throughout the premises or by means of coded audible signals or visual signals similarly distributed, or by means of lamp annunciators located throughout the premises.

Process Monitoring Alarm System. An alarm system used to supervise the functioning of a commercial process, such as manufacturing operations, heating or refrigerating systems temperature control, etc., when failure of the supervised process could result in fire or explosion endangering life or property.

Process Monitoring Service System. A system used to supervise the normal functioning of a commercial process, where an abnormal condition does not constitute a fire or explosion emergency.

Protective Signaling Systems. Electrically operated circuits, instruments, and devices, together with the necessary electrical energy, designed to transmit alarms and supervisory and trouble signals necessary for the protection of life and property. In a compressed or liquefied gas-type system, pressure-operated instruments and devices, together with the necessary compressed gas energy to accomplish the same purpose, are used.

Protective Systems, Equipment or Apparatus. Automatic sprinklers, standpipes, carbon-dioxide systems, automatic covers, and other devices used for extinguishing fires and for controlling temperatures or other conditions dangerous to life or property.

Shall. Indicates a mandatory requirement.

Should. Indicates a recommendation or that which is advised but not required.

Supervisory Service. The service required to monitor performance of guard's tours and the operative condition of automatic sprinkler systems and of other systems for the protection of life and property.

Supervisory Signal. A signal indicating the need of action in connection with the supervision of guard's tours, sprinkler and other extinguishing systems or equipment, or the maintenance features of other protective systems.

Supplementary. As used in this standard, supplementary refers to equipment or operation not required by this standard and designated as such by the authority having jurisdiction.

Trouble Signal. An audible signal indicating trouble of any nature, such as a circuit break or ground, occurring in the devices or wiring associated with a protective signaling system. In a compressed or liquefied gas-type system, the trouble signal indicates trouble of any nature, such as a break or a leak in the tanks, devices, or tubing of the system.

Chapter 2 Basic Requirements

2-1 Installation and Design.

2-1.1 Installation and Design (All Systems).

2-1.1.1 Systems. All systems shall be installed in a workmanlike manner and in accordance with applicable standards and with specifications approved by the authority having jurisdiction.

2-1.1.2 Devices shall be located and installed so that accidental operation will not be caused by vibration or jarring.

2-1.1.3 Pre-Signal Feature. When approved by the authority having jurisdiction, signaling systems having sounding devices within the protected premises may be so designed that initial fire signals will sound only in department offices, engine rooms, fire brigade stations, and other central locations, with provisions whereby authorized persons may subsequently sound a general alarm.

2-1.1.4 Local control functions, necessary to make the premises safer in the event of fire, or to make it possible to hear fire alarm signals, may be automatically performed. The performance of automatic control functions shall not interfere with power for lighting or for operating elevators. This does not preclude the combination of fire

protective signaling services with other services requiring monitoring of operations.

2-1.1.5 Coded Signals. A coded alarm signal shall consist of not less than three complete rounds of the number transmitted. A coded supervisory signal may consist of one round of the number transmitted.

2-1.1.6 Restoration. All apparatus shall be restored to normal as promptly as possible after each test or alarm, and kept in normal condition for operation. This shall include rewinding, resetting, or replacement, as necessary.

2-1.2 Installation and Design. (Special Features Applying to Electrical Systems Only.)

2-1.2.1 Grounding. All systems shall test free of grounds.

Exception: Parts of circuits or equipment which are intentionally and permanently grounded to provide ground-fault detection, noise suppression, emergency ground signaling, and circuit protective grounding.

2-1.3 Installation and Design. (Special Feature Applying to Gas-Operated Systems.)

2-1.3.1 General. Tubing and fittings for interconnecting components of gas-operated systems shall be of a material suitable for the application. Recognition by a testing laboratory may constitute suitability.

2-1.3.2 Restriction of Length. The total length of tubing in any system shall not be greater than that specified by a testing laboratory.

2-1.3.3 Installation. Tubing may be installed exposed on ceilings and on sidewalls if not less than 7 ft (2 m) from the floor, and if adequately protected against injury. Exposed tubing shall be supported by suitable fasteners, straps or hangers at intervals not exceeding 4½ ft (1.4 m) and within 12 in. (300 mm) from every device, cabinet or fitting. Fasteners used for this purpose shall be designed and installed to prevent mechanical damage to the tubing. Concealed tubing, or tubing passing through floors or walls, or located on side walls within 7 ft (2 m) of the floor shall be protected by installation in pipe, conduit, raceway, or other means acceptable to the authority having jurisdiction.

2-1.3.4 Clearance of Lines. As each section of tubing is installed, it shall be blown clear with compressed air or other compressed gas before connections to system components, so as to eliminate any accumulation of dirt or moisture within the tubing.

2-1.3.5 Where tubing and fittings are exposed to a corrosive atmosphere, they shall be protected by a suitable coating.

2-2 Wiring.

2-2.1 The installation of wiring and equipment shall be in accordance with NFPA 70, Article 760, Fire Protective Signaling Systems, *National Electrical Code*.

2-2.2 An open, ground, or short circuit fault in one alarm indicating circuit shall not affect the operation of any other alarm indicating circuit.

2-3 Power Supply Sources.

2-3.1 Purpose. The provisions of this section apply to sources of power supply which shall be used, for the type of system involved, subject to acceptance by the authority having jurisdiction.

2-3.2 Code Conformance. All power supplies shall be installed in conformity with the requirements of NFPA 70, National Electrical Code, for such equipment, except as otherwise indicated in this section.

2-3.2.1 Two sources of electrical power shall be provided. These shall consist of a primary (main) supply and a secondary (standby) supply.

2-3.3 Primary (Main) Power Supply. The primary (main) power supply shall have a high degree of reliability, adequate capacity for the intended service, and shall consist of one of the following:

- (a) Light and power service arranged in accordance with 2-3.7.
- (b) Engine-driven generator or equivalent arranged in accordance with 2-3.8.

2-3.4 Secondary (Standby) Power Supply Capacity and Sources.

2-3.4.1 The secondary (standby) power supply shall automatically supply the energy to the system within 30 seconds whenever the primary (main) power supply is incapable of providing the minimum voltage required for proper operation. The secondary (standby) power supply shall not supply energy as long as the primary power supply voltage remains above 85 percent of rated voltage. The secondary (standby) power supply shall be capable of operating the system under maximum normal load for 24 hours and then be capable of operating the system for five minutes in the alarm condition. The secondary (standby) power supply shall consist of one of the following:

- (a) A storage battery with 24 hours capacity arranged in accordance with 2-3.9.
- (b) An engine-driven generator arranged in accordance with 2-3.8 and storage batteries with 4 hours capacity arranged in accordance with 2-3.9.
- (c) Multiple automatic-starting, engine-driven generators, arranged in accordance with 2-3.8, capable of supplying the energy required by 2-3.4.1 with the largest generator out of service.

Exception No. 1: When the primary (main) power is supplied by a dedicated branch circuit of an Emergency System to NFPA 70 Article 700 or a Legally Required Standby System to NFPA 70 Article 701.

Exception No. 2: When the primary (main) power is supplied by a dedicated branch circuit of an Optional Standby System to NFPA 70 Article 702 which also meets the performance requirements of Article 700 or Article 701.

NOTE to Exceptions No. 1 and 2: A trouble signal is not required to indicate that the primary (main) power is being supplied by either of the two standby sources of power indicated above.

2-3.5 Trouble Power Supply. A separate power supply, independent of the primary (main) power supply, shall be provided for the operation of trouble signals when the primary (main) power supply fails. A primary battery (dry cells) shall not be used to power the trouble signals.

Exception No. 1: The secondary (standby) power supply of 2-3.4.1 (a), (b) or (c) may be used for this purpose.

Exception No. 2: The other side or "phase" of the three-wire supply of 2-3.7.1(b) may be used for this purpose.

2-3.6 Power Supply for Remotely Located Control Equipment. Additional power supplies, when provided for control units, circuit interfaces, or other equipment essential to system operation located remote from the main control unit, shall meet the applicable requirements of 2-3.1 through 2-3.5.

2-3.7 Light and Power Service.

2-3.7.1 A light and power service employed to operate the system under normal conditions shall have a high degree of reliability and capacity for the intended service. This service shall consist of one of the following:

- (a) Two-wire Supplies: A two-wire supply circuit may be used for either the primary (main) operating power supply or the trouble signal power supply of the signaling system.
- (b) Three-wire Supplies: A three-wire ac or dc supply circuit having a continuous unfused neutral conductor or a polyphase ac supply circuit having a continuous unfused neutral conductor, where interruption of one phase does not prevent operation by the other phase, may be used with one side or phase for the primary (main) operating power supply and the other side or phase for the trouble signal power supply of the signaling system.

2-3.7.2 Connections to the light and power service shall be on a dedicated branch circuit. The circuit and connections shall be mechanically protected. The circuit disconnecting means shall be accessible only to authorized personnel and shall be clearly marked FIRE ALARM CIRCUIT CONTROL.

2-3.8 Engine-Driven Generator.

2-3.8.1 An engine-driven generator shall be used only where a person specifically trained in its operation is on duty at all times.

Exception: When the requirement of 2-3.4.1(b) or (c) is met, a person specifically trained in the operation of a generator dedicated to the protective signaling system shall not be required to be on duty at all times.

2-3.8.2 The installation of such units shall conform to the provisions of NFPA 37, Standard for the Installation and Use of Stationary Combustion Engines and Gas Turbines, except as restricted by the provisions of this section.

2-3.8.3 When gasoline is used as main fuel, it shall be stored in outside underground tanks whenever possible and gravity tanks shall not be used.

2-3.8.4 Sufficient fuel shall be available in storage for 6 months of testing plus 24 hours of operation at full load.

Exception No. 1: If a reliable source of supply is available at any time on 2-hour notice, sufficient fuel shall be in storage for 12 hours of operation at full load.

Exception No. 2: Fuel systems using natural or manufactured gas supplied through reliable utility mains shall not be required to have fuel storage tanks unless located in an earthquake-prone area.

2-3.8.5 A separate storage battery and separate automatic charger shall be provided for starting the engine-driven generator and shall not be used for any other purpose.

2-3.9 Storage Batteries.

2-3.9.1 Adequate facilities shall be provided to automatically maintain the battery fully charged under all conditions of normal operation. After the fully charged battery is subjected to a single discharge cycle as specified in 2-3.4.1, the charging current shall be such that the battery capacity after 48 hours complies with the requirements of 2-3.4.1. Upon attaining a fully charged condition, the trickle charge rate shall not be excessive so as to result in battery damage.

2-3.9.2 Storage batteries shall be so located or enclosed that the equipment of the signaling system including overcurrent protective devices will not be affected adversely by battery gases. Installation of the batteries shall conform to the requirements of Article 480, NFPA 70, *National Electrical Code*.

2-3.9.3 The method of charging a battery shall provide either integral meters or readily accessible terminal facilities for the connection of portable meters by which the battery voltage and charging current can be determined.

2-3.10 Special Features Applying to Gas-Operated System Power Supplies.

2-3.10.1 When each automatic fire detector in a system has its own compressed gas supply tank to provide power for operation of an audible alarm signal or signals, each tank shall have sufficient capacity to produce at least a 5-minute alarm signal. Where a single supply tank is used to power the audible alarm signals, it shall have sufficient capacity to operate all audible signals connected thereto for at least 5 minutes. There shall be a visual indication showing a distinctive color so long as there is sufficient gas in any alarm signal power supply tank to operate the audible signals for the required 5 minutes. This color shall change to clear when the gas is depleted sufficiently to produce less than a 5-minute signal. In lieu of the visual indication an audible trouble signal may be provided to indicate a supply insufficient to produce at least a 5-minute signal.

2-3.10.2 Type of Gas. The compressed gas shall be nonflammable and not harmful to life under intended

conditions of use and limited in quantity so that the discharge of all the gas in the system shall not create any hazard to life through displacement of oxygen.

2-3.10.3 Construction of Containers. Containers for compressed gas shall conform to all applicable regulations of the U.S. Department of Transportation, Code of Federal Regulations, Title 49.

2-3.10.4 Full Discharge. A container of compressed gas utilized as a system power supply shall be connected into the system without a manual cutoff, so that when it is activated all the gas in the container will be expanded.

2-3.10.5 The filled weight and instructions for determining allowable weight loss shall be indicated on each compressed gas container. Each compressed gas power supply container shall be weighed after filling and the weight noted on the container. Gas containers shall be stored on the premises of the manufacturer or installing company for not less than 30 days and weighed again just prior to installation. Any filled containers showing weight loss shall not be used.

2-4 Electrical Supervision (Electrical Systems).

2-4.1 General. Except as otherwise indicated in this standard, all fire alarm and process monitoring alarm systems shall be electrically supervised so that the occurrence of a single open or a single ground-fault condition of its installation-wiring which prevents the required normal operation of the system or failure of its primary (main) power supply source will be indicated by a distinctive trouble signal. (See 2-4.4.)

NOTE 1: The provision of a double loop or other multiple-path conductor circuit to avoid electrical supervision is not acceptable.

NOTE 2: Unless otherwise indicated, electrical supervision of conductors for a short-circuit fault is not contemplated by this requirement. A multiple-ground condition is considered the equivalent of a short-circuit fault.

2-4.2 Electrical Supervision.

2-4.2.1 Power Supply Circuits. All sources of energy shall be supervised.

Exception No. 1: One employed for the operation of trouble signal circuits and appliances.

Exception No. 2: One employed as an auxiliary means for maintaining the normal operation of the system following trouble signal indication when the primary (main) supply source is interrupted.

Exception No. 3: One employed as a means for operating a supplementary circuit for alarm bells, annunciators, time stamps and similar circuits, the failure of which will not prevent the operation of the system for the required signals.

Exception No. 4: The battery leads of a float- or trickle-charged battery.

Exception No. 5: The neutral of a three-, four-, or five-wire ac or dc supply source.

2-4.2.2 Signal Initiating Circuits. All installation-wiring for signals initiated by the operation of fire alarm boxes, fire detectors, automatically operated transmitters, or other appliances or devices which initiate or

transmit signals either manually or automatically shall be supervised.

Exception No. 1: A noninterfering shunt circuit, provided that a fault condition of the shunt circuit wiring results only in the loss of the noninterfering feature of operations.

Exception No. 2: Pneumatic rate-of-rise systems of the continuous line type where the wiring terminals of such devices are connected in parallel across electrically supervised circuits.

2-4.2.3 Audible Alarm Indicating Circuits. All installation-wiring for operating audible alarm indicating appliances shall be electrically supervised. In addition, a short-circuit fault in these circuits shall be indicated by a trouble signal.

Exception No. 1: The installation-wiring of an audible alarm indicating appliance installed in the same room with a system control unit, provided the circuit conductors are installed in conduit or equivalently protected against mechanical injury or tampering.

Exception No. 2: The installation-wiring of a supplementary audible alarm indicating appliance, provided that any fault condition of this circuit wiring does not prevent the required operation of the system.

2-4.2.4 Visual Alarm Indicating Circuits. All installation-wiring for operating visual alarm indicating appliances shall be electrically supervised.

Exception: The installation-wiring of a supplementary signal annunciator or other supplementary visual alarm appliance, provided that any fault condition of this circuit wiring does not affect the required operation of the system.

2-4.2.5 Speaker Amplifier and Tone Generating Equipment. When speakers are used to produce audible fire alarm signals, the following shall apply:

(a) Failure of the audio amplifier shall result in an audible trouble signal.

(b) Failure of the tone generating equipment shall result in an audible trouble signal.

(c) Tone generating and amplifying equipment, enclosed as integral parts, and serving only a single listed audible signaling appliance, need not be supervised.

2-4.2.6 Trouble Signal Circuit. Electrical supervision of the trouble signal installation-wiring shall not be required.

2-4.2.7 Connections of Installation-Wiring. Connections of installation-wiring to alarm initiating devices and alarm indicating appliances shall be electrically supervised.

2-4.2.8 Supplementary Circuits. Supplementary circuits, such as those for operating fan motor stops or similar equipment, shall not be required to be electrically supervised, provided a fault condition of the circuit in no way affects the required operation of the signaling system.

2-4.3 Supervision of Gas-Operated System.

2-4.3.1 The tubing between detectors shall be supervised so that a leak will be manifested by an audible signal distinctive from alarm signals and operated by a separate power supply. The trouble signal power supply may be electrical and taken from the public utility light and power circuit or from a battery. If taken from the public utility light and power circuit, it shall be a separate fused circuit not used for any other purpose.

2-4.3.2 When only one compressed gas tank is used in a system to sound an alarm, this tank shall be supervised so that an audible trouble signal will be sounded if the tank loses enough gas to reduce the period of audible alarm signal to less than 5 minutes.

2-4.3.3 The audible trouble signal operation specified in 2-4.3.2 shall not be required where each detector of a system has its own compressed gas supply tank capable of operating all audible alarm signals. Tubing shall be supervised as described in 2-4.3.1.

2-4.4 Trouble Signals (All Systems).

2-4.4.1 General. Trouble signals shall be distinctive from alarm signals and shall be indicated by the operation of a sounding appliance. If an intermittent signal is used, it shall sound at least once every 10 seconds with a minimum time duration of one-half second. An audible trouble signal may be common to several supervised circuits. The trouble signal(s) shall be located in an area where it is likely to be heard, as designated by the authority having jurisdiction.

2-4.4.2 Silencing Switch. A switch or valve for silencing the audible trouble signal sounding appliance shall be permitted only if it transfers the trouble indication to a lamp or other acceptable visible indicator adjacent to the switch. The visual indication shall persist until the trouble has been corrected. The audible trouble signal shall sound if the switch or valve is in its "silence" position and no trouble exists.

2-5 Audible Signal Appliances.

2-5.1* General. Audible signal appliances employed in fire alarm systems for alarm, supervisory, and trouble signals include electro-mechanical and gas-operated appliances such as bells, horns, buzzers, chimes, sirens; integral electronic tone generating appliances (tone generator, amplifier, and speaker in a common housing); and speakers energized by a remote amplifier source. The suitability of the type of appliance to be employed for a particular application and its location shall be determined by the local authority having jurisdiction.

2-5.2 Common Requirements.

2-5.2.1 Audible signal appliances shall be listed for fire protective signaling service.

2-5.2.2 Audible signal appliances shall be protected against the effects of temperature, vermin, corrosion, humidity, and physical damage.

2-5.3 Additional Requirements for Speakers. Speakers employed in fire alarm systems for tone signals

and/or emergency voice communications shall have a frequency response and power rating suitable for the application. Speaker materials which are subject to moisture absorption shall be suitably impregnated.

2-5.4* Distribution of Evacuation Signals. Fire alarm systems provided for evacuation of occupants shall have one or more audible signaling appliances approved for the purpose on each floor of the building, so located that their operation will be heard clearly regardless of the maximum noise level obtained from machinery or other equipment under normal conditions of occupancy. Each section of a floor divided by a fire wall may be considered as a separate floor for the purpose of this protection.

2-5.5 Distinctive Signals. Audible signal appliances for a fire alarm system shall produce signals which are distinctive from other similar appliances used for other purposes in the same area. The distinction among signals shall be as follows:

(a)* Fire alarm signals shall be distinctive in sound from other signals and this sound used for no other purpose.

(b) Supervisory signals shall be distinctive in sound from other signals and this sound shall not be used for any other purpose except it may be employed to indicate a trouble condition.

(c) Fire alarm, supervisory, and trouble signals shall take precedence over all other signals.

2-5.6 Alarm Signal Silencing. A switch for silencing the alarm signal sounding appliances shall be permitted only if it is key-operated or located within a locked cabinet. Such a switch shall be permitted only if it transfers the alarm indication to a lamp or other visual indicator, and subsequent alarms in other zones will operate the alarm signal sounding devices. A switch that is left in the "silence" position when there is no alarm shall operate a visual alarm silence indicator and cause the trouble signal to sound until the switch is restored to normal.

2-6 Signal Capacity of Circuits.

2-6.1 General.

2-6.1.1 The number of signal-transmitting devices connected to any signaling circuit shall be limited to avoid interference. The total number of code wheels connected to a single circuit shall not exceed 250.

2-6.1.2 The number of water flow switches which may be connected to actuate a single transmitter shall not exceed five, and the number of supervisory switches which may be connected to actuate a single transmitter shall not exceed 20.

2-6.2 Combined Alarm and Supervisory Signal Circuits. When both sprinkler supervisory signals and fire or water flow alarm signals are transmitted over the same signaling circuit, provision shall be made to either obtain alarm signal precedence or sufficient repetition of the alarm signal to prevent the loss of any alarm signal transmitting devices.

2-6.3 Loading Capacity of Watch Supervisory Signal Circuits. Connections to watch supervisory signal circuit or to a combination manual fire alarm and watch signal circuit shall be so limited that not more than 60 scheduled watch report signals will be transmitted in any one-hour period. Patrol scheduling shall be such as to avoid interference between watch report signals.

2-7 Combination Systems.

2-7.1 Scope. The provisions of this section apply to the types of equipment used in common for fire protective signaling systems, such as for fire alarm, sprinkler supervisory or watch service, and for other signaling systems, such as burglar alarm, voice paging or music program systems, or coded paging systems, and to methods of using circuit wiring common to both types of system.

2-7.2 Wiring Common to Both Types of System. When common wiring is employed for combination systems, the equipment for other than fire protective signaling system use shall be connected to the common wiring of the system in such a manner that short circuits, or open circuits, or grounds in this equipment or between this equipment and the fire protective signaling system wiring will not interfere with either the supervision of the fire system or prevent alarm or supervisory signal transmission.

2-7.3 Use of Speakers. Speakers shall be permitted to provide the audible alarm signal for local fire alarm or sprinkler alarm systems as well as the use of these same speakers for voice paging or music programs. See Section 2-5 for additional speaker requirements.

2-7.4 Operation. In combination systems, the operation shall be as follows:

(a) A fire alarm signal shall be clearly recognizable and take precedence over any other signal even though a nonfire alarm signal is initiated first.

(b) Distinctive alarm signals shall be obtained between fire alarm and other functions, such as burglar alarm.

2-8 Visual Zone Alarm Indication. When required by the authority having jurisdiction, the location of an operated initiating device shall be visually indicated by building, floor, fire zone, or other approved subdivision by annunciation, printout, or other approved means. The visual indication shall not be cancelled by the operation of an audible alarm silencing switch.

Chapter 3 Types of Signaling Services

3-1 Purpose. The provisions of this chapter apply to signaling services which may be provided individually or in combination by different types of systems except as otherwise indicated for each type of system.

3-2 Manual Fire Alarm Service.

3-2.1 Fire Alarm Boxes.

3-2.1.1 Manual fire alarm boxes shall be approved for the particular application and shall be used only for fire

protective signaling purposes. Combination fire alarm and guard's tour boxes are acceptable.

3-2.1.2 Each box shall be securely mounted. The bottom of the box shall be not less than 3½ ft (1.1 m) and not more than 5 ft (1.4 m) above the floor level.

3-2.1.3 Manual fire alarm boxes shall be distributed throughout the protected area so that they are unobstructed, readily accessible, and located in the normal path of exit from the area, and as follows:

(a) At least one box shall be provided on the first floor and on each succeeding alternate floor except that one box shall be provided for each floor where the area is 10,000 sq ft (929 m²) or more.

(b) Additional boxes shall be provided so that travel distance to the nearest box will not be in excess of 200 ft (61 m).

3-2.1.4* Coded Alarm Signal. A coded alarm signal shall consist of not less than three complete rounds of the number transmitted and each round shall consist of not less than three impulses.

3-3 Guard's Tour Supervisory Service.

3-3.1 General.

3-3.1.1 The number of guard's reporting stations, their locations, and the route to be followed by the guard for operating the stations shall be approved for the particular installation.

3-3.1.2 A permanent record indicating each time each signal-transmitting station is operated shall be made at the main control unit. When intermediate stations which do not transmit a signal are employed in conjunction with signal-transmitting stations, distinctive signals shall be transmitted at the beginning and end of each tour of a guard and a signal-transmitting station shall be provided at intervals not exceeding ten stations. Intermediate stations which do not transmit a signal shall be capable of operation only in a fixed order of succession.

3-3.2 Suppressed (Exception Reporting) Signal Device.

3-3.2.1 The system shall comply with the provisions of 3-3.1.1.

3-3.2.2 The system shall transmit a "start" signal to the main control unit and shall be initiated by the guard at the start of continuous tour rounds.

3-3.2.3 The system shall automatically transmit a "delinquency" signal within 15 minutes after a predetermined time if the guard fails to actuate tour stations as scheduled.

3-3.2.4 A "finish" signal shall be transmitted with a predetermined schedule after the guard completes the last tour of the premises.

3-3.2.5 For periods of over 24 hours, during which tours are continuously conducted, a "start" signal shall be transmitted at least once every 24 hours.

3-3.2.6 The "start," "delinquency," and "finish" signals shall be recorded at the main control unit.

3-4 Automatic Fire Detection and Alarm Service.

3-4.1 General.

3-4.1.1 Automatic fire detectors shall be located, maintained, and tested in accordance with NFPA 72E, the *Standard on Automatic Fire Detectors*.

3-4.1.2 Automatic fire detectors which have integral trouble contacts shall be wired on the initiating device circuit so that a trouble condition on one detector will not impair the alarm operation from other initiating devices.

3-4.2 Special Features on Gas-Operated Systems.

3-4.2.1 For test purposes, each compressed gas-operated system shall have a manually operated cylinder of gas installed in the tubing at the point most remote from the alarm-sounding device. If branch tubing circuits are installed, a test cylinder shall be installed at the end of each branch of tubing so the entire tubing circuit will be tested. A manual test cylinder may be provided with a shutoff valve and used repeatedly for tests until the supply of gas is exhausted. A check valve shall be installed so that a manual test cylinder can be removed for replacement without interfering with the operation of the system in case of fire. In systems using low pressure for pressurizing the tubing for supervision purposes, means shall be provided to bleed off the high pressure resulting from the use of the above test cylinder. Means shall also be provided to repressurize at low pressure to restore supervision of this tubing.

3-4.2.2 A manual test cylinder shall be distinct and separate from a manually operated cylinder installed for supplementary alarm signal purposes in accordance with 3-4.2.1. A supplementary manual alarm cylinder shall comply with all of the requirements of 2-3.10.

3-5 Sprinkler System Water Flow Alarm and Supervisory Signal Service.

3-5.1 Purpose.

3-5.1.1* The provisions of this article apply to sprinkler system signaling attachments for indicating the flow of water in the system and for indicating the off-normal condition of a sprinkler system component which may affect the performance of the system adversely.

3-5.2 General.

3-5.2.1 A dry-pipe sprinkler system equipped for water flow alarm signals shall provide supplementary supervision of the system air pressure to avoid false signals due to neglect in maintaining air pressure.

3-5.2.2 Signals transmitted shall indicate distinctively the particular function (such as valve position, temperature pressure, etc.) of the automatic sprinkler system which is abnormal and its restoration to a normal condition.

3-5.2.3 A signal attachment and its circuits shall be so designed and installed that they cannot be readily tampered with or removed without causing a signal to be produced. This specifically includes junction boxes on the outside of the buildings.

3-5.3 Water Flow Alarm Service.

3-5.3.1* Provision shall be made to indicate the flow of water in a sprinkler system by an alarm signal. The water flow signaling attachment shall operate to indicate an alarm in accordance with the *Standard for the Installation of Sprinkler Systems*, NFPA 13.

Exception: Movement of water due to waste, surges, or variable pressure need not be indicated.

3-5.4 Supervisory Signal Services.

3-5.4.1 Provision shall be made for supervising the required conditions which are essential for the proper operation of sprinkler systems.

Exception: Those conditions related to water mains, tanks, cisterns, reservoirs, and other containers of water controlled by a municipality or a public utility.

3-5.4.2 A control valve shall be supervised to obtain a distinctive signal indicating movement of the valve from its normal position. The off-normal signal shall be obtained either during the first two revolutions of a hand wheel or when the stem of the valve has moved one-fifth of the distance from its normal position.

(a) Where the initiating device of two or more valves utilizes a common circuit an off-normal signal shall remain until all of the valves of the group are in their normal positions.

(b) An initiating device for supervising the position of a gate valve shall not interfere with the operation of the valve nor obstruct the view of its indicator nor prevent access to its stuffing box.

(c) The off-normal signal shall not be restored at any valve position except normal.

NOTE: Cancellation of the off-normal signal is acceptable as the restoration signal.

3-5.4.3 Pressure sources shall be supervised to obtain a distinctive signal indicating that the required pressure is abnormal.

(a) A pressure supervisory initiating device for a pressure tank shall detect both high and low pressure conditions. A signal shall be obtained when the pressure is increased or decreased 10 psi (69 kPa) from the required pressure value.

(b) A pressure supervisory initiating device for a dry-pipe sprinkler system shall detect both high and low pressure conditions. A signal shall be obtained when the required pressure is increased or decreased in accordance with requirements of the authority having jurisdiction.

(c) A steam pressure supervisory initiating device shall detect a low pressure condition. A signal shall be obtained when the normal pressure is reduced to a value which is not less than 110 percent of the minimum operating pressure of the steam-operated equipment supplied.

(d) An initiating device for supervising the pressure of other sources than those specified above shall be capable of being applied and operated as required by the authority having jurisdiction.

3-5.4.4 Water storage containers shall be supervised to obtain a distinctive signal indicating that the required water level is abnormal (high or low).

(a) A pressure tank supervisory initiating device shall detect both abnormally high and low level conditions. A signal shall be obtained when the water level is lowered or raised 3 in. (76 mm) from the required level.

(b) A supervisory initiating device for other than pressure tanks shall detect a low level condition. A signal shall be obtained when the water level is lowered 12 in. (300 mm) from the required level.

3-5.4.5 Water storage containers shall be supervised to obtain a distinctive signal indicating that the temperature of the water has been lowered to 40°F (4°C).

3-5.4.6 Fire pumps shall be supervised in accordance with the requirements of NFPA 20, *Standard for the Installation of Centrifugal Fire Pumps*, and the authority having jurisdiction. When both sprinkler supervisory signals and pump running signals are transmitted over the same signaling circuit, provision shall be made to obtain pump running signal preference unless the circuit is so arranged that no signals shall be lost.

Chapter 4 Referenced Publications

4-1 The following documents or portions thereof are referenced within this standard and shall be considered part of the requirements of this document. The edition indicated for each reference is current as of the date of the NFPA issuance of this document. These references are listed separately to facilitate updating to the latest edition by the user.

4-1.1 **NFPA Publications.** National Fire Protection Association, Batterymarch Park, Quincy, MA 02269.

NFPA 13-1985, *Standard for the Installation of Sprinkler Systems*

NFPA 20-1983, *Standard for the Installation of Centrifugal Fire Pumps*

NFPA 37-1984, *Standard for the Installation and Use of Stationary Combustion Engines and Gas Turbines*

NFPA 70-1984, *National Electrical Code*

NFPA 72E-1984, *Standard on Automatic Fire Detectors*

Appendix A

This Appendix is not part of the requirements of this NFPA document . . . but is included for information purposes only.

A-2-5.1 It is recommended that at least one audible fire alarm signal be located outside the building to alert persons in the vicinity who in turn could summon fire fighting assistance.

A-2-5.4 To ensure that audible evacuation signals are clearly heard, it is recommended that their sound level be at least 15 dBA above the equivalent sound level or 5 dBA above the maximum sound level having a duration of at least 60 seconds (whichever is greater) measured 5 ft (1.5 m) above the floor in the occupiable area. The equivalent sound level is the mean square, A-weighted sound pressure measured over a 24-hour period.

A-2-5.5(a) When a distinctive fire alarm signal is to be used to notify the building occupants of the need to evacuate (leave the building), the use of a national standard fire alarm evacuation signal is recommended to facilitate quick and positive recognition of the signal.

The recommended fire alarm evacuation signal is a uniform Code 3 temporal pattern, using any appropriate sound, keyed 1/2 to 1 second "ON," 1/2 second "OFF," 1/2 to 1 second "ON," 1/2 second "OFF," 1/2 to 1 second "ON" and 2 1/2 seconds "OFF," with timing tolerances of ± 25%, repeated for not less than 3 minutes.

Exception: The minimum repetition time may be manually interrupted.

The recommended standard fire alarm evacuation signal is intended for use *only* as an evacuation signal. Its use should be restricted to situations where it is desired to have all occupants hearing the signal evacuate the building immediately. It should not be used when, with the approval of the authority having jurisdiction, the planned action during a fire emergency is not evacuation, but relocation of the occupants from the affected area to a safe area within the building, or their protection in place (e.g., high rise buildings, health care facilities, penal institutions, etc.).

A-3-2.1.4 Coded Signal Designations. The following suggested coded signal assignment for buildings having four floors and basements is provided as a guide:

Location	Coded Signal
Fourth Floor	2-4
Third Floor	2-3
Second Floor	2-2
First Floor	2-1
Basement	3-1
Sub-basement	3-2

A-3-5.1.1 It is recommended that premises having a sprinkler system equipped to provide a water flow alarm signal have supplementary means for manually transmitting an alarm signal located in the normal path of exit from the area.

A-3-5.3.1 Care should be taken, when designating water flow alarm systems for sprinklers utilizing on-off heads, to ensure that an alarm will be received in the event of a water flow condition. On-off sprinklers open at

a predetermined temperature and close when the temperature reaches a predetermined lower temperature. With certain types of fires, water flow may occur in a series of short bursts of 10 to 30 seconds duration each. Water flow detection devices with retard may not detect water flow under these conditions. It is recommended that an excess pressure system or one which operates on pressure drop be considered to facilitate water flow detection on sprinkler systems utilizing on-off sprinklers.

Excess pressure systems may be used without or with alarm valves. The following is a description of one type of excess pressure system with an alarm valve.

An excess pressure system with alarm valve consists of an excess pressure pump with pressure switches to control the operation of the pump. The inlet of the pump is connected to the supply side of the alarm valve and the outlet is connected to the sprinkler system. The pump control pressure switch is of the differential type maintaining the sprinkler system pressure above the main pressure by a constant amount. Another switch monitors low sprinkler system pressure to initiate a trouble signal in the event of a failure of the pump or other malfunction. An additional pressure switch may be used to stop pump operation in the event of a deficiency in water supply. Another pressure switch is connected to the alarm outlet of the alarm check valve to initiate a water flow alarm signal when water flow exists. This type of system also inherently prevents false alarms due to water surges. The sprinkler alarm retard chamber should be eliminated to enhance the detection capability of the system for short duration flows.

Appendix B Referenced Publications

B-1 The following documents or portions thereof are referenced within this standard for informational purposes only and thus should not be considered part of the requirements of this document. The edition indicated for each reference is current as of the date of the NFPA issuance of this document. These references are listed separately to facilitate updating to the latest edition by the user.

B-1.1 NFPA Publications. National Fire Protection Association, Batterymarch Park, Quincy, MA 02269.

NFPA 72H-1984, *Guide for Testing Procedures for Local, Auxiliary, Remote Station and Proprietary Protective Signaling Systems*

B-1.2 Other Publications.

Code of Federal Regulations, Title 49, October 1, 1973, U.S. Government Printing Office, Washington, D.C.

A14.127 SMOKE DETECTION SYSTEMS, HEAT DETECTION SYSTEMS, SMOKE DETECTORS AND HEAT DETECTORS. The following is a partial reprint of NFPA Nos. 72E and 74.

NFPA No. 72E

Chapter 8

Chapter 8 Maintenance and Testing

8-1 General.

8-1.1 Each automatic detector shall be maintained in reliable operating condition. Periodic inspections and tests shall be made to assure proper maintenance as specified herein.

8-1.1.1 Maintenance and testing shall be in accordance with this standard supplemented by the manufacturer's instructions and those of the authority having jurisdiction.

8-1.2 Detectors shall be under the supervision of a responsible person who shall cause proper tests to be made at specified intervals and have general charge of all alterations and additions.

8-1.3 In any tests, all persons who would automatically receive an alarm shall be notified, so that an unnecessary response shall not take place.

8-1.4 After installation, a visual inspection of all detectors shall be made to be sure that they are properly located.

8-1.5 After installation, each detector shall be checked to ensure that it is properly connected and powered in accordance with the manufacturer's recommendations.

8-1.6 Any method or device used for testing in a hazardous atmosphere or process shall be suitable for use within the hazardous atmosphere or process.

8-1.7 A permanent record of all test results shall be kept on the premises for at least five years for review by the authority having jurisdiction.

8-2 Initial Installation Tests.

8-2.1 Heat Detectors.

8-2.1.1 A restorable heat detector shall be tested with a heat source, such as a hair dryer or shielded heat lamp, until it responds. After each heat test, the detector shall reset. Precaution shall be taken to avoid damage to the nonrestorable fixed temperature element of a combination rate-of-rise/fixed temperature detector.

Exception: A pneumatic tube line-type detector shall be tested either with a heat source (if a test chamber is in the circuit) or tested pneumatically with a pressure pump. The manufacturer's instructions shall be followed.

8-2.1.2 Line- or spot-type nonrestorable fixed temperature heat detectors shall not be heat tested, but shall be tested mechanically or electrically for fire alarm function. Line-type detectors shall have their loop resistance measured to see if it is within acceptable limits for the equipment being used. The loop resistance shall be recorded for future reference. The record shall be maintained on the premises. Other tests shall be performed as required by the manufacturers.

8-2.1.3 Detectors with a replaceable fusible alloy element shall be tested by:

- (a) removing the fusible element to determine that the detector contacts operate properly, and then
- (b) reinstalling the fusible element.

8-2.2 Smoke Detectors.

8-2.2.1 To assure that each smoke detector is operative, it shall be tested, in place, in accordance with the manufacturer's instructions.

8-2.2.2 Detector sensitivity shall be determined using either:

- (a) A calibrated test method, or
- (b) The manufacturer's calibrated sensitivity test instrument, or
- (c) Other calibrated sensitivity test method acceptable to the authority having jurisdiction.

Detectors found to be outside the approved range of sensitivity shall be replaced.

Exception: If the detector is listed as field adjustable, it may be either adjusted to bring it within an approved range or replaced.

NOTE: The detector sensitivity cannot be tested or measured using any spray device that administers an unmeasured concentration of aerosol into the detector.

8-2.3 Flame Detectors, Fire-Gas Detectors and Other Fire Detectors. Flame detectors, fire-gas detectors and other fire detectors shall be tested for operation in accordance with instructions supplied by the manufacturer or other test methods acceptable to the authority having jurisdiction.

8-3 Periodic Tests.

8-3.1* Detectors shall be tested as described in the following paragraphs. The method of test shall be as outlined in Section 8-2. The authority having jurisdiction may accept testing at a greater or lesser frequency.

8-3.2 Heat Detectors.

8-3.2.1 For nonrestorable spot-type detectors, after the fifteenth year at least two detectors out of every hundred, or fraction thereof, shall be removed every five years and sent to a testing laboratory for tests. The detectors that have been removed shall be replaced with new detectors. If a failure occurs on any of the detectors removed, additional detectors shall be removed and tested as a further check on the installation until there is proven to exist either a general problem involving faulty detectors or a localized problem involving only one or two defective detectors.

8-3.2.2 For restorable heat detectors (except pneumatic line-type), one or more detectors on each signal-initiating circuit shall be tested at least semiannually and different detectors shall be selected for each test. Within five years, each detector shall have been tested.

8-3.2.3 All pneumatic line-type detectors shall be tested for leaks and proper operation at least semiannually.

8-3.2.4 Nonrestorable line-type fixed temperature detectors shall be tested for alarm function at least semiannually. The loop resistance shall be measured, recorded

and compared with that previously recorded. Any change in loop resistance shall be investigated.

8-3.3 Smoke Detectors.

8-3.3.1 All smoke detectors shall be tested at least semiannually. (See 8-2.2.) Except where a different frequency is required or permitted by the authority having jurisdiction, the sensitivity test cited in 8-2.2.2 shall be performed within one year after installation and every alternate year thereafter.

8-3.3.2 Air duct detector testing and maintenance shall consist of:

(a) A visual inspection of the detector installation, including seals, looking for any mistreatment or modification of the device or installation and its intended operation.

(b) Using the manufacturer's recommendations, verify that the device will measure/detect smoke in the air stream (i.e., measuring pressure drop for devices using sampling tubes is acceptable).

(c) Using the manufacturer's recommended procedures, determine that the sensitivity of the detection devices is correct.

(d) Using smoke or a substitute, or a calibrated test method, perform a full-functional test of the detector, put the detector into alarm, and determine that proper operation occurs. This can be done by directly injecting the smoke or a substitute into the detection chamber or sampling means.

8-3.4 Flame Detectors, Fire-Gas Detectors and Other Fire Detectors. All flame detectors, fire-gas detectors and other fire detectors shall be tested at least semiannually as prescribed by the manufacturer and more often if found to be necessary for the application.

8-4 Cleaning and Maintenance. Detectors require periodic cleaning to remove dust or dirt which has accumulated. The frequency of cleaning will depend upon the type of detector and the local ambient conditions. For each detector, the cleaning, checking, operation, and sensitivity adjustment shall be attempted only after consulting the manufacturer's instructions.

8-5 Tests Following an Alarm. All detectors shall be restored to service as promptly as possible after each test or alarm, and shall be kept in normal condition for operation. Detectors requiring resetting or replacement shall be reset or replaced as promptly as possible after each test or alarm. All detectors exposed to a fire shall be tested.

8-6 Inspection Forms.

8-6.1 An inspection form shall be provided and include the following information on initial tests:

- (a) Date.
- (b) Name of property.
- (c) Address.
- (d) Installer/maintenance company name, address and representative.

(e) Approving agency(ies) name, address, and representative.

(f) Number and type of detectors per zone for each zone.

(g) Functional test of detectors. (See Section 8-2.) (Warning: See also 8-1.3.)

(h) Check of all smoke detectors. (See 8-2.2.1.)

(i) Loop resistance for all fixed temperature line-type detectors. (See 8-2.1.2.)

(j) Other tests as required by equipment manufacturers.

(k) Signature of tester and approval authority representative.

8-6.2 An inspection form shall be provided and include the following information for periodic tests:

(a) Date.

(b) Test frequency.

(c) Name of property.

(d) Address.

(e) Maintenance company name, address and representative.

(f) Approving agency(ies) name, address, and representative.

(g) Designation of the detector(s) tested (tests performed in accordance with Section 8-3).

(h) Functional test of detectors. (See Section 8-2.) (Warning: See also 8-1.3.)

(i) Check of all smoke detectors. (See 8-2.2.1.)

(j) Loop resistance for all fixed temperature line-type heat detectors. (See 8-2.1.2.)

(k) Other tests as required by equipment manufacturers.

(l) Signatures of tester and approval authority representative.

NFPA No.74

Chapter 6

Chapter 6 Maintenance and Tests

6-1* Maintenance. If batteries are used as a source of energy they shall be replaced in accordance with the recommendations of the alarm equipment manufacturer.

6-2* Tests. Tests or inspections, as recommended by the manufacturer, shall be made by the householder not less than once a month for other than battery-powered detectors and not less than once a week for battery-powered detectors.

A14.128 PORTABLE FIRE EXTINGUISHERS. The following is a partial reprint of NFPA No. 10 dealing with testing, inspection and maintenance of portable fire extinguishers:

4-1.3 The owner or occupant of a property in which extinguishers are located shall be responsible for such inspection, maintenance, and recharging.

4-1.4* Maintenance, servicing and recharging shall be performed by trained persons having available the appropriate servicing manual(s), the proper types of tools, recharge materials, lubricants, and manufacturer's recommended replacement parts.

4-2 Definitions.

4-2.1 **Inspection.** Inspection is a "quick check" that an extinguisher is available and will operate. It is intended to give reasonable assurance that the extinguisher is fully charged and operable. This is done by seeing that it is in its designated place, that it has not been actuated or tampered with, and that there is no obvious or physical damage or condition to prevent operation.

4-2.2 **Maintenance.** Maintenance is a "thorough check" of the extinguisher. It is intended to give maximum assurance that an extinguisher will operate effectively and safely. It includes a thorough examination and any necessary repair or replacement. It will normally reveal the need for hydrostatic testing.

4-2.3 **Recharging.** Recharging is the replacement of the extinguishing agent and also includes the expellant for certain types of extinguishers.

4-3 Inspection.

4-3.1* **Frequency.** Extinguishers shall be inspected monthly, or at more frequent intervals when circumstances require.

4-3.2 **Procedures.** Periodic inspection of extinguishers shall include a check of at least the following items:

- (a) Located in designated place.
- (b) No obstruction to access or visibility.
- (c) Operating instructions on nameplate legible and facing outward.
- (d) Seals and tamper indicators not broken or missing.
- (e) Determine fullness by weighing or "hefting."
- (f) Examine for obvious physical damage, corrosion, leakage, or clogged nozzle.
- (g) Pressure gage reading or indicator in the operable range or position.

4-3.3 **Corrective Action.** When an inspection of any extinguisher reveals a deficiency in any of the conditions listed in (a) and (b) of 4-3.2, immediate corrective action shall be taken.

4-3.3.1 **Rechargeable Extinguishers.** When an inspection of any rechargeable extinguisher reveals a deficiency in any of the conditions listed in (c), (d), (e), (f), and (g) of 4-3.2, it shall be subjected to applicable maintenance procedures.

4-3.3.2 **Nonrechargeable.** When an inspection of any nonrefillable disposable extinguisher reveals a deficiency in any of the conditions listed in (c), (e), (f), and (g) of 4-3.2, it shall be discharged and removed from service.

Chapter 4 Inspection, Maintenance, and Recharging

4-1 General.

4-1.1 This chapter is concerned with the rules governing inspection, maintenance, and recharging of extinguishers. These factors are of prime importance in ensuring operation at the time of a fire.

4-1.2 The procedure for inspection and maintenance of fire extinguishers varies considerably. Minimal knowledge is necessary to perform a monthly "quick check" or inspection in order to follow the inspection procedure as outlined in Section 4-3. A trained person who has undergone the instructions necessary to reliably perform maintenance and has the manufacturer's service manual shall service the fire extinguishers not more than one year apart, as outlined in Section 4-4.

4-3.4 Recordkeeping.

4-3.4.1 Personnel making inspections shall keep records for those extinguishers that were found to require corrective actions.

4-3.4.2 At least monthly, the date the inspection was performed and the initials of the person performing the inspection shall be recorded.

4-4* Maintenance.

4-4.1 Frequency. Extinguishers shall be subjected to maintenance not more than one year apart or when specifically indicated by an inspection. Maintenance procedures shall be performed in accordance with 4-4.2.

4-4.1.1 Stored pressure types containing a loaded stream agent shall be disassembled on an annual basis and subjected to a complete maintenance. Prior to disassembly the extinguisher shall be fully discharged to check the operation of the discharge valve and pressure gage.

4-4.1.2* A conductivity test shall be conducted on all carbon dioxide hose assemblies. Hose assemblies found to be nonconductive shall be replaced.

4-4.1.3 Every six years, stored pressure extinguishers that require a 12-year hydrostatic test shall be emptied and subjected to the applicable maintenance procedures. When the applicable maintenance procedures are performed during periodic recharging or hydrostatic testing, the six-year requirement shall begin from that date.

Exception No. 1: Extinguishers having nonrefillable disposable containers are exempt.

4-4.1.4 Extinguishers out of service for maintenance or recharge shall be replaced by spare extinguishers of the same type and at least equal rating.

4-4.2* Procedures. Maintenance procedures shall include a thorough examination of the three basic elements of an extinguisher:

- (a) mechanical parts,
- (b) extinguishing agent, and
- (c) expelling means.

Exception No. 1: It is not necessary during the annual maintenance to internally examine CO₂ or stored pressure extinguishers equipped with pressure indicators or gages except for those types specified in 4-4.1.1. HOWEVER, such extinguishers shall be thoroughly examined externally in accordance with the applicable items of 4-4.2(a).

Exception No. 2: Factory sealed ("disposable type") extinguishers shall be inspected and maintained only in accordance with the nameplate instructions.

4-4.3* Recordkeeping. Each extinguisher shall have a tag or label securely attached that indicates the month and year the maintenance was performed and shall identify

the person performing the service.¹ The same record tag or label shall indicate if recharging was also performed.

4-4.3.1 For the six-year requirement of 4-4.1.3, this information shall be included on the maintenance tag or label. This information shall be transferred to each subsequent maintenance tag or label.

4-4.3.2 Labels indicating inspection, maintenance, hydrostatic retests, and six-year maintenance shall not be placed on the front of the extinguisher.

4-5 Recharging.

4-5.1* General. All rechargeable type extinguishers shall be recharged after use or as indicated by an inspection or when performing maintenance. When performing the recharging, the recommendations of the manufacturers shall be followed. For recharge chemicals, see 4-5.3.1.

4-5.2 Frequency.

4-5.2.1 Soda-Acid, Foam, and Pump-Tank. Every 12 months, soda-acid, foam, pump-tank water, and pump-tank calcium chloride base antifreeze types of extinguishers shall be recharged with new chemicals or water, as applicable.

4-5.2.2 Wetting Agent. The agent in stored pressure wetting agent (wet chemical) extinguishers shall be replaced annually.

NOTE: Only the agent specified on the nameplate shall be used for recharging. The use of water or other agents is prohibited.

4-5.2.3 AFFF. The agent, liquid or solid charge type, in AFFF (aqueous film forming foam) extinguishers shall be replaced at least once every five years.

4-5.3 Procedures.

4-5.3.1* Recharge Chemicals. Only those materials specified on the nameplate, or materials proven to have equal chemical composition and physical characteristics, shall be used. Tests shall be conducted to assure equal performance.

4-5.3.2* Mixing of Agents. Multipurpose dry chemicals shall not be mixed with alkaline based dry chemicals.

4-5.3.3 Topping Off. The remaining agent in a partially discharged dry chemical extinguisher shall be thoroughly checked for the proper type, contamination and condition. Dry chemical found to be of the wrong type, or contaminated, shall be removed.

4-5.3.4 Dry Powder. Pails or drums containing dry powder agents for scoop or shovel application for use on metal fires shall be kept full and covered at all times. The dry powder shall be replaced if found damp. (See A-4-5.3.1.)

¹Under special circumstances or when local requirements are in effect, additional information may be desirable or required on record tags.

4-5.3.5* Replacement pressure gages shall have the proper indicated charging (service) pressure, be marked for use with the agent in the extinguisher and be compatible with the extinguisher valve body material. The gage used to set the regulated source of pressure shall be calibrated at least annually.

4-5.3.6 Precautionary Pressurization Measures. A rechargeable stored pressure type extinguisher shall be pressurized only to the charging pressure specified on the extinguisher nameplate. A regulated source of pressure, set no higher than 25 psi (172 kPa) above the operating (service) pressure, shall be used to pressurize fire extinguishers.

NOTE: An unregulated source of pressure, such as a nitrogen cylinder without a pressure regulator, should never be used because the extinguisher could be overpressurized and possibly rupture.

4-5.3.7* Pressurizing Gas. Only standard industrial grade nitrogen with a dew point of -70°F (-57°C) or lower shall be used to pressurize stored pressure dry chemical and Halon type fire extinguishers. Compressed air through moisture traps shall not be used for pressurizing even though so stated in the instructions on older extinguishers.

4-5.3.8 Conversion of Extinguisher Types. No extinguisher shall be converted from one type to another, nor shall any extinguisher be converted to use a different type of extinguishing agent.

4-5.3.9* Removal of Moisture. For all nonwater types of extinguishers any moisture shall be removed before recharging.

4-5.3.10* Carbon Dioxide Recharging. The vapor phase of carbon dioxide shall not be less than 99.5 percent carbon dioxide. The water content of the liquid phase shall not be more than 0.01 percent by weight [-30°F (-34.4°C) dew point]. Oil content of the carbon dioxide shall not exceed 10 ppm by weight.

4-5.3.11* Leak Test. After recharging, a leak test shall be performed on stored pressure and self-expelling types.

4-5.3.12 Recharging Water Types. When recharging stored pressure extinguishers, overfilling will result in improper discharge. The proper amount of liquid agent shall be determined by using one of the following:

- (a) exact measurement in gallons, or by weight
- (b) use of an antioverfill tube when provided, or
- (c) use of a fill mark on extinguisher shell, if provided.

Chapter 5 Hydrostatic Testing

5-1 General.

5-1.1 Hydrostatic testing shall be performed by persons trained in pressure testing procedures and safeguards, and having available suitable testing equipment, facilities and appropriate servicing manual(s).

5-1.2 If, at any time, an extinguisher shows evidence of corrosion or mechanical injury, it shall be hydrostatically tested, subject to the provisions of 5-1.3 and 5-1.4.

Exception No. 1: Pump tanks do not require a hydrostatic test.

Exception No. 2: Extinguishers having nonrefillable disposable containers shall be discharged and discarded.

5-1.3 Examination of Cylinder Condition. When an extinguisher cylinder or shell has one or more conditions listed in this subdivision, it shall not be hydrostatically tested but shall be destroyed by the owner or at his direction:

(a) When there exists repairs by soldering, welding, brazing, or use of patching compounds.

NOTE: For welding or brazing on mild steel shells, consult the manufacturer of the extinguisher.

(b) When the cylinder or shell threads are damaged.

(c) When there exists corrosion that has caused pitting, including under removable nameplate band assemblies.

(d) When the extinguisher has been burned in a fire.

(e) When a calcium chloride type of extinguishing agent was used in a stainless steel extinguisher.

(f) When the shell is of copper or brass construction joined by soft solder or rivets.

5-1.4* Aluminum Shell/Cylinder. Extinguishers having aluminum cylinders or shells suspected of being exposed to temperatures in excess of 350°F (177°C) shall be removed from service and subjected to a hydrostatic test.

5-2 Frequency. At intervals not exceeding those specified in Table 5-2, extinguishers shall be hydrostatically tested.

Exception No. 1: Nonrefillable factory-sealed disposable containers do not require hydrostatic testing.

Exception No. 2: Extinguishers utilizing a cylinder that has DOT or CTC markings shall be hydrostatically tested, or replaced, according to the requirements of DOT or CTC.

Exception No. 3: For extinguishers not covered in Exceptions No. 1 and 2 the first retest may be conducted within 12 months of the specified test intervals.

5-2.1 Compressed Gas Cylinders and Cartridges. Nitrogen cylinders or cartridges used for inert gas storage used as an expellant for wheeled extinguishers shall be hydrostatically tested every five years.

Exception: Cylinders (except those charged with carbon dioxide) complying with Part 173.34 (e) 15, Title 49, Code of Federal Regulations, may be hydrostatically tested every 10 years.

5-2.2 Hose Assemblies. A hydrostatic test shall be performed on extinguisher hose assemblies which are equipped with a shutoff nozzle at the end of the hose. The test interval shall be the same as specified for the extinguisher on which the hose is installed.

Table 5-2

Hydrostatic Test Interval for Extinguishers

Extinguisher Type	Test Interval (Years)
Soda Acid	5
Cartridge-Operated Water and/or Antifreeze	5
Stored Pressure Water and/or Antifreeze	5
Wetting Agent	5
Foam	5
AFFF (Aqueous Film Forming Foam)	5
Loaded Stream	5
Dry Chemical with Stainless Steel Shells	5
Carbon Dioxide	5
Dry Chemical, Stored Pressure, with Mild Steel Shells, Braze Brass Shells, or Aluminum Shells	12
Dry Chemical, Cartridge- or Cylinder-Operated, with Mild Steel Shells	12
Bromotrifluoromethane Halon 1301	12
Bromochlorodifluoromethane Halon 1211	12
Dry Powder, Cartridge- or Cylinder-Operated, with Mild Steel Shells	12

NOTE 1: All types of extinguishers with copper or brass shells joined by soft solder are prohibited from hydrostatic testing. (See 5-1.3(f).)

NOTE 2: Stored pressure water extinguishers with fiber glass shells (pre-1976) are prohibited from hydrostatic testing due to manufacturer's recall.

5-3 Test Pressures.

5-3.1 Compressed Gas Cylinders.

5-3.1.1 Carbon dioxide extinguishers shall be tested at 2/3 the service pressure as stamped into the cylinder.

Exception: Carbon dioxide extinguishers having cylinder specification ICC3 shall be tested at 3,000 psi (20 685 kPa).

5-3.1.2 Nitrogen cylinders and carbon dioxide cylinders used with wheeled extinguishers shall be tested at 2/3 the service pressure as stamped into the cylinder.

5-3.2 Stored Pressure Types. All stored pressure and bromochlorodifluoromethane (Halon 1211) types of extinguishers shall be hydrostatically tested at the factory test pressure not to exceed two times the service pressure.

5-3.3 Self-Generating and Cartridge-Operated Types.

5-3.3.1 Self-generating types (soda acid and foam) of stainless steel construction and cartridge operated water type extinguishers of stainless steel construction shall be hydrostatically tested at 350 psi (2413 kPa). (For those of aluminum shell construction, see 5-1.4.)

5-3.3.2 Cartridge- or cylinder-operated dry chemical and dry powder types of extinguishers shall be hydrostatically tested at their original factory test pressure as shown on the nameplate or shell.

5-3.4 Test Pressures for Hose Assemblies.

5-3.4.1 Carbon dioxide hose assemblies requiring a hydrostatic pressure test shall be tested at 1,250 psi (8619 kPa).

5-3.4.2 Dry chemical and dry powder hose assemblies requiring a hydrostatic pressure test shall be tested at 300 psi (2068 kPa) or at service pressure, whichever is the higher.

5-4 Test Equipment and Procedures.

5-4.1 General.

5-4.1.1 Air or gas pressure shall not be used for pressure testing. The failure of an extinguisher shell may be violent and dangerous.

5-4.1.2 When extinguisher shells, cylinders, or cartridges fail a hydrostatic pressure test, they shall be destroyed by the owner or at his direction.

5-4.2 Test Equipment for Compressed Gas Types.

5-4.2.1 The equipment for testing cylinders and cartridges shall be of the water jacket type that meets the specifications of the pamphlet *Methods for Hydrostatic Testing of Compressed Gas Cylinders* (Pamphlet C-1), published by the Compressed Gas Association.

5-4.2.2 Hose assemblies of carbon dioxide extinguishers that require a hydrostatic test shall be tested within a protective cage device.

5-4.3* Test Equipment for Noncompressed Gas Types.

5-4.3.1 The equipment for testing noncompressed gas types consists of the following:

(a) A hydrostatic test pump, hand or power operated, to be capable of producing not less than 150 percent of the test pressure. It is to include appropriate check valves and fittings.

(b) A flexible connection for attachment to the test pump. It shall be provided with necessary fittings to test through the extinguisher nozzle, test bonnet, or hose outlet, as is applicable.

(c) A protective cage or barrier for personnel protection, designed to provide visual observation of the extinguisher under test.

5-4.3.2 Drying equipment is required to dry all non-water types of extinguishers that have passed the hydrostatic test.

5-5 Testing Procedures.

5-5.1 Compressed Gas Types.

5-5.1.1 In addition to the visual examinations required prior to test as stated in 5-1.3, an internal examination shall be made prior to the hydrostatic test. The procedures for this internal examination shall be in accordance with the requirements of the *Standard for Visual Inspection of Compressed Gas Cylinders* (CGA C-6) and *Standard for Visual Inspection of High Pressure Aluminum Compressed Gas Cylinders* (CGA C-6.1), published by the Compressed Gas Association.

5-5.1.2 The hydrostatic testing of compressed gas cylinders and cartridges shall be in accordance with the procedures specified in the pamphlet *Methods for Hydrostatic Testing of Compressed Gas Cylinders* (Pamphlet C-1), published by the Compressed Gas Association.

5-5.2* **Testing Procedures for Noncompressed Gas Types.** The testing procedures for noncompressed gas cylinders and shells and hose assemblies are detailed in Appendix A of this standard.

5-5.3* **Testing Procedures for Hose Assemblies.** The testing procedures for hose assemblies requiring a hydrostatic test are detailed in Appendix A.

5-5.4 **Recording of Tests.**

5-5.4.1 **Compressed Gas Types.** For compressed gas cylinders and cartridges passing a hydrostatic test, the month and year shall be stamped into the cylinder in accordance with the requirements set forth by DOT or the Canadian Transport Commission.

NOTE: It is important that the recording (stamping) be placed only on the shoulder, top head, neck, or footing (when so provided) of the cylinder.

5-5.4.2* **Noncompressed Gas Types.** Extinguisher shells of the noncompressed gas types that pass a hydrostatic test shall have the test information recorded on a suitable metallic label or equally durable material. The label shall be affixed by a heatless process to the shell. These labels shall be self-destructive when removal from an extinguisher shell is attempted. The label shall include the following information:

- (a) Month and year the test was performed, indicated by a perforation, such as by a hand punch.
- (b) Test pressure used.
- (c) Name or initials of person performing the test, or name of agency performing the test.

5-5.4.3 **Hose assemblies passing a hydrostatic test do not require recording.**

A14.135 MEANS OF EGRESS. The following is a reprint of ss. ILHR 51.15 to 51.20 and related sections from the occupancy chapters:

MEANS OF EGRESS

GENERAL

ILHR 51.15 Standard exit. (1) Every door which serves as a required exit from a public passageway, stairway or building shall be a standard exit door unless exempted by the occupancy requirements of this code.

Note: See ss. ILHR 54.06, 55.10, 56.08, 57.06, 58.04, 58.49, 59.14, 60.12, 61.12, 62.26, 62.47 and 62.75 for requirements regarding required exits.

(2) Every standard exit door shall swing outward or toward the natural means of egress. It shall be level with the floor, and shall be so hung that, when open, it will not block any part of the required width of any other doorway, passageway, stairway or fire escape. No revolving door, overhead door or sliding door shall be considered as a standard exit. **FP**

(3) (a) A standard exit door shall have such fastenings or hardware that it can be opened from the inside by pushing against a single bar or plate or turning a single knob or handle. The latch or other approved fastening device on the door shall be of an obvious method in its release. Except as provided in pars. (b) to (d), the installation of hardware requiring use of a key for opening an exit door from the inside is prohibited. The requirements of this subsection, except par. (f) shall apply to all buildings in existence and to any building built after the effective date of this subsection.

(b) Exit and exit access doors serving individual living units may be provided with hardware requiring the use of a key for opening from the inside.

(c) Upon written request to the department by the owner, key-locking, or securing, of exits may be approved in fire-resistive buildings, or parts of fire-resistive buildings, which are used as jails, prisons, mental institutions, asylums, nursing homes with senile patients, and similar type occupancies.

Note #1: The owners request should include the following considerations: accessibility of keys to the fire department and staff personnel for the locked areas; electrical devices which release the locks; and 24-hour supervision of the locked areas by personnel who carry keys for the locked areas while on duty. Electrical devices which release the locks upon power failure or upon activation of the fire alarm or sprinkler system or the product of combustion detectors should be considered for securing of exits in nursing homes.

Note #2: Written approval to lock exits must also be obtained from the department of health and social services in accordance with the rules of that department.

(d) 1. One door serving as an exit from any building housing any office or wholesale or retail store may be equipped with hardware which requires use of a key to open it from the inside provided one of the following conditions is satisfied: **FP**

a. The door has a window which has a minimum clear opening of not less than 24 inches, and 6 square feet in area with the bottom of the window opening not more than 4 feet above the inside floor level;

b. A glazed sidelight satisfying the dimensional and location requirements for the windows specified in par. (a) is located adjacent to the door; or

51.15

76

WISCONSIN ADMINISTRATIVE CODE

ILHR 51

Definitions and standards

c. A window satisfying the dimensional and location requirements for the window specified in par. (a) is located within five feet of the door.

2. Approved safety glazing shall be used in all installations but the glazing may not be bullet-resistant or break-resistant.

3. The door may not be used as an exit serving any required exit stairway enclosure.

4. The door shall not be key-locked during periods of occupancy by the public or employees. A readily visible, permanent sign shall be placed on or adjacent to the door on the egress side stating, "THIS DOOR SHALL NOT BE KEY-LOCKED WHEN THE BUILDING IS OCCUPIED". The sign shall be in letters at least one inch in height on a contrasting background.

5. The use of keyed hardware as specified in this section may be revoked by the department or its authorized deputy upon one violation of any of the conditions specified in subs. 1. to 4.

(e) 1. Except as provided in subd 2., the door shall not be barred, bolted or chained at any time.

2. When authorized persons, such as employees, frequenters, patrons and other such occupants are not present, the exit door may be secured by the use of a single bar or bolt. A sign or label shall be posted on the door near the single bar or bolt. The sign or label shall bear the following: "This bolt or bar shall be kept open during periods of occupancy."

Note: The intent of subd. 2. is to prohibit padlocks or use of a key to open a door or lock at any time. The bar and bolt exception is to give security against intruders from the outside while protecting persons in the building from being trapped.

(f) 1. Except as provided in subd. 2., the latch or other approved fastening device shall be located on the exit door so that the device is not less than 32 inches or more than 54 inches above the floor level.

2. The latch or approved fastening device on solid tempered glass doors may be located on the door at the floor line.

FP (4) A standard exit door shall not be less than 6 feet 4 inches high by 3 feet 0 inches wide, except where especially provided under occupancy classifications and in s. ILHR 51.20. Where double doors are provided with or without mullions, the width of each single door may be reduced to 2 feet 6 inches, except double doors utilized to provide accessibility in accordance with s. ILHR 52.04 shall have the width of at least one single door increased to 2 feet 8 inches.

(5) All exit doors, unless otherwise exempted by the occupancy requirements of this code, shall be plainly marked by a red illuminated translucent exit sign bearing the word EXIT or OUT in plain letters not less than 5 inches in height and in such other places as may be necessary to direct the occupants to exit doorways.

(6) * **REQUIRED AGGREGATE WIDTH.** (a) The required aggregate width of exits from a level shall be determined by using the full occupant load of that level, plus the percentage effects of the occupant loads of adjacent levels (above and below) which exit through it as follows:

*See Appendix A for further explanatory material.

DEPT. OF INDUSTRY, LABOR & HUMAN RELATIONS 77
Definitions and standards ILHR 51

- 1. 50% of the occupant load of each first-adjacent level; and
- 2. 25% of the occupant load of each second-adjacent level.

(b) The width shall be based upon the following ratios:

- 1. Types No. 1 through No. 4 construction unsprinklered, 40 inches per 100 persons;
- 2. Types No. 5 through No. 8 construction unsprinklered, 50 inches per 100 persons;
- 3. Types No. 1 through No. 4 construction sprinklered, 30 inches per 100 persons; or
- 4. Types No. 5 through No. 8 construction sprinklered, 40 inches per 100 persons.

Note: The determination of exit width for health care facilities is specified in s. ILHR 58.12 (2) and (3) and takes precedence over this section.

(c) The required aggregate width of exits from assembly seating facilities shall comply with the requirements of s. ILHR 62.75 (4).

History: 1-2-56; am. Register, December, 1962, No. 84, eff. 1-1-63; am. (5) and cr. (7), Register, November, 1963, No. 95, eff. 12-1-63; r. and recr., Register, October, 1967, No. 142, eff. 11-1-67; am. (7) (j), Register, May, 1968, No. 149, eff. 6-1-68; r. and recr. (7), Register, December, 1970, No. 180, eff. 1-1-71; r. and recr. (3), Register, February, 1971, No. 182, eff. 3-1-71; am. (7) (a) 1., Register, September, 1973, No. 213, eff. 10-1-73; r. (7), r. and recr. (6), Register, December, 1974, No. 228, eff. 1-1-75; emerg. cr. (3) (b) 1., eff. 6-20-75; cr. (3) (a) 1. and (3) (b) 1., Register, November, 1975, No. 239, eff. 12-1-75; am. (4), Register, December, 1977, No. 264, eff. 1-1-78; am. (2) and (3) (b) 1., Register, December, 1978, No. 276, eff. 1-1-79; am. (4), Register, January, 1980, No. 289, eff. 2-1-80; am. (2), r. and recr. (3) (a), (intro.), cr. (6) (c), Register, December, 1981, No. 312, eff. 1-1-82; cr. (3) (c), Register, December, 1983, No. 336, eff. 1-1-84; r. and recr. (3), Register, January, 1985, No. 349, eff. 2-1-85; am. (3) (a) and (4), cr. (3) (e) and (f), Register, August, 1985, No. 356, eff. 1-1-86.

ILHR 51.151 Exit distribution. All spaces which can accommodate more than 25 persons shall be provided with a minimum of 2 exits, 2 exit access doors or a combination of both which are located to provide the best possible egress from the room or suite. If exit access doors are used, the exit access corridors shall lead to 2 or more separate exits.

Note 1: See Appendix A for further explanatory material.

Note 2: See occupancy chs. ILHR 54 to 62 for acceptable types of exits and exit accesses and exceptions.

History: Cr. Register, August, 1985, No. 356, eff. 1-1-86.

ILHR 51.16 Stairways and ramps (1) DEFINITIONS. (a) "Stairway" means one or more flights of steps, and the necessary platforms or landings connecting them, to form a continuous passage from one elevation to another, including exterior porches, platforms and steps.

(b) "Ramp" means a sloping floor or walk and necessary platforms or landings connecting them to form a continuous passage from one elevation to another.

(2) **REQUIRED AGGREGATE WIDTH.** (a) The required aggregate width of stairway or ramp exits from any level shall be as specified in s. ILHR 51.15 (6).

(b) In no case shall the minimum width of an exit stair or ramp be less than that specified in sub. (3).

51.16

78 WISCONSIN ADMINISTRATIVE CODE

ILHR 51

Definitions and standards

(c) Under no circumstances shall stairways or ramps decrease in width in the line of travel toward the exit.

(3) MINIMUM WIDTH. (a) Except as provided in par. (b), every required exit stairway or ramp under chs. ILHR 54 to 62 shall be not less than 3 feet 8 inches wide, except as provided in the occupancy chapters, of which not more than 4 inches on each side may be occupied by a hand-rail. The clear dimension between handrails, or stringers, shall not be less than 3 feet 0 inches.

(b) 1. Nonrequired stairways or ramps need not conform to the width requirements specified in chs. ILHR 50 to 64.

2. Stairway chair lifts, but not platform lifts, for the physically disabled may be installed on the right side as one mounts the stairs on required exit stairways of buildings constructed prior to May 14, 1974.

a. A clear stair width of 24 inches measured from the lift, in its open position, to the nearer edge of the opposite handrail and a clear dimension of 3 feet between the lift mounting track or traveling means and the handrail shall be provided.

b. The lift shall be designed and installed to maintain the code required exit passageway or stair width when the lift is in the parked or stored position.

c. Lifts may not encroach more than 24 inches into the net width determined by s. ILHR 51.15 (6), when in the operating configuration.

(4) RISERS, TREADS AND RAMP SLOPES. Risers and treads shall be designed and provided in accordance with the following:

(a) All stairways and steps shall have a rise of not more than 7¾ inches and a tread not less than 9½ inches, measured from tread to tread and from riser to riser. Treads and risers shall be uniform in any one flight. Winders shall not be used;

Note #1: The department recommends that steps be proportioned so the sum of 2 risers and a tread, exclusive of its nosing or projection, should be not less than 24 inches or more than 25 inches.

Note #2: The department may accept nonstandard exit stairways serving unoccupied areas, such as equipment mezzanines or platforms, and similar areas, if approved in writing.

Note #3: Round or smooth nosings are recommended as they are not difficult to negotiate for individuals with restrictions in the knee, ankle or hip, or with artificial legs or long leg braces.

(b) The edges of all treads and the edges of all stairway landings shall be finished with a nonslippery surface not less than 3 inches in width;

(c) Where an exit door leads to an outside platform or sidewalk, the level of the platform or sidewalk shall not be more than 7¾ inches below the doorsill;

(d) Every stairway flight shall have at least 3 risers (unless additional safety is provided which meets the approval of the department); and

(e) There shall be no more than 22 risers in any one flight.

(f) 1. Ramp slopes of required exit ramps may not exceed 1:8.

DEPT. OF INDUSTRY, LABOR & HUMAN RELATIONS 79
Definitions and standards ILHR 51

2. Ramp slopes of all ramps not included under subd. 1. may not exceed 1:6.

Note: See s. ILHR 52.04 (7) for ramp requirements for barrier free design.

(g) Ramps and landings shall be finished with a slip-resistant surface.

(5) STAIRWAY AND RAMP LANDINGS AND PLATFORMS. (a) 1. Except as provided in subd. 2., if a door is provided at the head or foot or both of a stairway or ramp, a landing or platform shall be placed between the door and the stairway or ramp regardless of the direction of swing of the door.

2. Platforms may be omitted for ramps 6 foot or less in length.

(b) Every landing or platform shall be at least as wide as the stairway or ramp, measured at right angles to the direction of travel. Every landing or platform must have a length of at least 3 feet, measured in the direction of travel.

(c) Spaces beneath stairs and ramps may not be enclosed for any use. FP

(6) CURVED STAIRS. Interior or exterior curved stairs used as required exits shall meet all the requirements for stairways. Curved stairs shall have a radius of at least 25 feet at the interior edge of the tread.

(7) SPIRAL STAIRS. Spiral stairways may be permitted as specifically allowed by the occupancy chapters of this code. Such spiral stairs shall provide a clear walking area measuring at least 22 inches from the outer edge of the supporting column to the inner edge of the handrail and shall have treads at least 7 inches in width at a point one foot from the narrow end of the tread, and a uniform riser height of not more than 8 inches.

History: 1-2-56; am. (2); (2) (a); (2) (b); Register, June, 1956, No. 6, eff. 7-1-56; r. and recr. Register, September, 1959, No. 45, eff. 10-1-59; r. (4) (b), renum. (c) to be (b), and cr. (5), Register, February, 1971, No. 182, eff. 3-1-71; am. (2) (a), Register, September, 1973, No. 213, eff. 10-1-73; r. and recr. Register, December, 1974, No. 228, eff. 1-1-75; am. (4) (a) and cr. (10), Register, December, 1977, No. 264, eff. 1-1-78; cr. (7) (a), Register, December, 1978, No. 276, eff. 1-1-79; r. (5) to (7), renum. (8) to (10) to be (5) to (7) and am. (7), Register, January, 1980, No. 289, eff. 2-1-80; r. and recr. (1), am. (2), (3) (a) and (5), renum. (3) (b) to be (3) (b) 1. and am., cr. (3) (b) 2., (4) (f) and (g), Register, August, 1985, No. 356, eff. 1-1-86.

ILHR 51.161 Handrails. (1) WHERE REQUIRED. Handrails shall be provided in all of the following conditions unless otherwise specified in the occupancy chapters of this code. FP

(a) On the left side, as one mounts the stairs or ramp, on all interior stairways of more than 3 risers and on all ramps overcoming a change in elevation of more than 24 inches.

(b) On the open side of any stairway with more than 3 risers and on the open side of any ramp overcoming a change in elevation of more than 24 inches.

(c) On both sides of interior stairways or ramps 5 feet or more in width.

(d) To divide interior stairways or ramps more than 8 feet wide into widths at least 3 feet 8 inches but less than 8 feet.

(e) On both sides of exterior stairways with more than 3 risers and on both sides of exterior ramps overcoming a change of elevation of more than 24 inches, either of which are an integral part of the building.

80 WISCONSIN ADMINISTRATIVE CODE

ILHR 51

Definitions and standards

(f) To divide exterior stairways or ramps, either of which are an integral part of the building and more than 25 feet wide into approximately equal widths not less than 3 feet 8 inches but not greater than 25 feet.

(g) The requirements specified in pars. (a) to (f) do not apply to ramps having a slope less than 1:20.

Note: See s. ILHR 52.04 (7) (c) for handrail requirements for ramps used to provide barrier free access.

(h) On fire escapes as specified in s. ILHR 51.20 (8).

(2) **LOADING.** All handrails shall be designed and constructed to withstand a load of 200 pounds applied in any direction at any point.

(3) **HEIGHT.** Handrails, except those serving fire escapes, shall be not less than 30 inches nor more than 34 inches above the nosing of the treads on stairways or above the surface of ramps.

Note: See s. ILHR 51.20 (8) for handrail requirements for fire escapes.

(4) **CONTINUITY AND EXTENSIONS.** (a) Except as provided in par. (b), handrails shall be continuous for the full length of the stairway or ramp and one handrail shall extend at least 12 inches beyond the top and bottom riser or ramp end and shall not constitute a projecting hazard.

(b) 1. Handrails not required for barrier-free design construction on assembly seating facilities need not comply with the 12 inch extension requirement.

2. Handrails on stairs located within individual living units need not comply with the requirements of par. (a).

(5) **CLEARANCE.** Handrails shall provide a clearance of at least 1½ inches between the handrail and the wall to which it is fastened.

(6) **OPENINGS BELOW TOP RAIL.** (a) Handrails protecting the open sides of stairways and ramps subject to use by children shall have intermediate rails or an ornamental pattern designed to prevent the passage of an object with a diameter larger than 9 inches.

(b) Handrails protecting the open sides of stairways and ramps not subject to use by children (i.e., waste water treatment plants, foundries, tanneries and other industrial occupancies) shall be provided with an intermediate rail at mid height or equivalent.

History: Cr. Register, January, 1980, No. 289, eff. 2-1-80; am. (4), Register, December, 1981, No. 312, eff. 1-1-82; am. (1) (a) to (g), renum. (4) (b) to be (4) (b) 1., cr. (4) (b) 2., Register, August, 1985, No. 356, eff. 1-1-86.

FP ILHR 51.162 Guardrails. (1) **WHERE REQUIRED.** Guardrails shall be provided in all of the following conditions unless otherwise specified in the occupancy chapters of this code:

(a) On the open side of elevated platforms, landings, walks, balconies and mezzanines which are more than 24 inches in height;

(b) On assembly seating facilities as specified in s. ILHR 62.77;

(c) On open parking structures as specified in s. ILHR 62.28 and as indicated in sub. (5); and

(d) On openings through floors and roofs.

Register, August, 1985, No. 356

DEPT. OF INDUSTRY, LABOR & HUMAN RELATIONS 81
Definitions and standards ILHR 51

(2) EXEMPT LOCATIONS. Guardrails need not be provided on the loading side of loading docks.

(3) LOADING. (a) Except as provided in par. (b), all guardrails shall be designed and constructed to withstand a load of at least 200 pounds applied in any direction at any point.

(b) All guardrails on assembly seating facilities shall be designed and constructed to withstand a vertical and horizontal load of 50 pounds per linear foot. Loads need not be applied simultaneously.

(4) HEIGHT. Guardrails shall not be less than 3 feet 6 inches in height.

(a) Exception. Guardrails within individual living units may be 36 inches in height.

(b) Exception. Guardrails on a balcony immediately in front of the first row of fixed seating and which are not at the end of an aisle may be 30 inches in height.

(5) OPENINGS BELOW TOP RAIL. (a) Guardrails in areas subject to use by children shall have intermediate rails or an ornamental pattern designed to prevent the passage of an object with a diameter larger than 9 inches.

(b) Guardrails in areas not subject to use by children shall be provided with an intermediate rail at mid height or equivalent.

History: Cr. Register, January, 1980, No. 289, eff. 2-1-80; am. (1) (b), (3) and (4) (b), Register, December, 1981, No. 312, eff. 1-1-82.

ILHR 51.164 Headroom. (1) GENERAL. Except as provided in sub. (2), every means of egress shall be provided with a headroom clearance of not less than 6 feet 8 inches. In stairways, the clearance shall be 7 feet 0 inches established by measuring vertically from the edge of the tread nosing to the ceiling or soffit above the tread nosing.

(2) EXCEPTION. The headroom clearance for public stairways in apartments and townhouses may be reduced to not less than 6 feet 8 inches.

Note: See s. ILHR 57.07 (3) for requirements pertaining to stairways within individual living units.

History: Cr. Register, January, 1980, No. 289, eff. 2-1-80; am. Register, December, 1983, No. 336, eff. 1-1-84.

ILHR 51.165 Stairway identification. All stairways serving 4 or more stories shall have each floor level or story identified on the stair side as to its name or number with a permanent sign having letters or characters at least 2 inches in height. **FP**

History: Cr. Register, December, 1981, No. 312, eff. 1-1-82.

ILHR 51.166 Stairway discharge. Where a stairway from the level below the exit discharge and a stairway from an upper floor terminate at the same exit discharge level, an approved barrier shall be provided to prevent persons from continuing down one or more full floor levels below the exit discharge level unless the exit discharge level has a vision panel to the outside or is otherwise made readily apparent. **FP**

History: Cr. Register, December, 1981, No. 312, eff. 1-1-82; am. Register, October, 1982, No. 322, eff. 11-1-82.

51.167

82

WISCONSIN ADMINISTRATIVE CODE

ILHR 51

Definitions and standards

FP ILHR 51.167 Exiting through areas of hazard. (1) **GENERAL.** Except as provided in subs. (2) and (3), exit access shall be so arranged that it will not be necessary to travel through any area of hazard in order to reach the exit.

Note: See ss. ILHR 54.14, 55.29, 56.15, 57.14, 58.24, 58.62, 59.21, 60.25, 60.37, 62.32 for additional requirements.

(2) **GARAGES.** (a) Occupancies within the scope of ch. ILHR 54 may exit through storage garages.

(b) Occupancies within the scope of ch. ILHR 54 may not exit through repair garages.

(c) Occupancies within the scope of chs. ILHR 55-62 may not exit through a storage or repair garage.

(3) **KITCHENS.** (a) Exiting through a kitchen within an individual living unit is permitted.

(b) Exiting through kitchens equipped with residential-type appliances in areas such as but not limited to employe lounges, activity rooms and similar areas is permitted provided the kitchen is not used for commercial purposes.

(c) Exiting through kitchens of restaurants and similar commercial operations or kitchens equipped with commercial-type appliances is prohibited.

History: Cr. Register, December, 1981, No. 312, eff. 1-1-82; am. Register, October, 1982, No. 322, eff. 11-1-82.

ILHR 51.17 Smokeproof stair tower. (1) A smokeproof stair tower shall be an enclosed stairway which is entirely cut off from the building and which is reached by means of open balconies or platforms. The stairways, landings, platforms and balconies shall be of noncombustible material throughout. The enclosing walls shall be of not less than 4-hour fire-resistive construction, and the floors and ceilings of not less than 2-hour fire-resistive construction as specified in s. ILHR 51.04.

(2) The doors leading from the buildings to the balconies and from the balconies to the stairways shall be fire-resistive doors, and all openings within 10 feet of any building shall be protected with fire-resistive windows for moderate fire exposure, or fire-resistive doors as specified in s. ILHR 51.047.

(3) Each balcony shall be open on at least one side, with a railing not less than 3'6" high on all open sides.

History: 1-2-56; am. Register, December, 1962, No. 84, eff. 1-1-63; am. (1) and (2), Register, February, 1971, No. 182, eff. 7-1-71; r. and recr. (1) and (2) eff. 8-1-71 and exp. 1-1-72, and cr. (1) and (2) eff. 1-1-72, Register, July, 1971, No. 187; am. (2), Register, June, 1972, No. 198, eff. 7-1-72.

ILHR 51.18 Interior enclosed stairway. (1) **GENERAL.** An interior enclosed stairway shall be separated from other areas of the building by fire-resistive rated construction as specified in ss. ILHR 51.04 to 51.049 with the hourly ratings as specified in Table 51.03-A.

(2) **EXTENT OF ENCLOSURE.** (a) The enclosure shall include at each floor level a portion of the floor which will be at least as wide as the stairway.

Register, August, 1985, No. 356

DEPT. OF INDUSTRY, LABOR & HUMAN RELATIONS 83
Definitions and standards ILHR 51

(b) The enclosure shall provide uninterrupted passage from the uppermost floor to an outside door without leaving the enclosure.

(c) The enclosure shall also include any passageway, if provided, on the floor of exit discharge leading from the stairway to the exit discharge, so as to afford uninterrupted passage from the uppermost floor to the exit discharge, without leaving the enclosure.

(3) OPENINGS IN THE ENCLOSURE. Openings in the stairway enclosure shall be limited to exit doors serving public passageways or corridors or serving floors occupied by a single tenant.

Note: See ch. Ind 4 for additional requirements pertaining to the location of elevator equipment room access doors.

(4) PROTECTION OF OPENINGS. (a) All openings for doors shall be protected by fire-rated door assemblies as specified in s. ILHR 51.047.

(b) If windows are provided in the enclosure, the window openings shall be protected by fixed fire-rated window assemblies as specified in s. ILHR 51.048, except in outside walls.

History: 1-2-56; am. (1) and (3), Register, February, 1971, No. 182, eff. 7-1-71; r. and recr. (1) and (3), eff. 8-1-71 and exp. 1-1-72, and cr. (1) and (3), eff. 1-1-72, Register, July, 1971, No. 187; r. and recr. (1), Register, June, 1972, No. 198, eff. 1-1-73; am. (3), Register, December, 1975, No. 240, eff. 1-1-76; am. (2), Register, January, 1980, No. 289, eff. 2-1-80; r. and recr., Register, December, 1981, No. 312, eff. 1-1-82.

ILHR 51.19 Horizontal exit. (1) GENERAL. A horizontal exit shall consist of one or more openings through an occupancy separation; a 2-hour fire-rated separation wall extending from the basement or lowest floor to the underside of the roof deck or of one or more bridges or balconies connecting 2 buildings or parts of buildings entirely separated by occupancy separations as described in s. ILHR 51.08.

(2) PROTECTION OF OPENINGS. Openings used in connection with horizontal exits shall be protected by fire-resistive doors as specified in s. ILHR 51.047.

(a) Doors serving as required exits shall be standard exit doors and shall swing in the direction of exit travel. Where a horizontal exit serves spaces on both sides of the wall, there shall be adjacent doorways equipped with doors which swing in opposite directions.

1. *Exceptions.* a. The swing of the exit door may comply with the exceptions permitted in the occupancy chapters of this code.

(b) Approved illuminated exit signs shall be provided to indicate the horizontal exit.

(c) Such doors shall be kept unlocked, unobstructed, provided with a self-closing device and normally be kept closed.

1. *Exception.* Doors protecting openings used in connection with horizontal exits may be left opened if equipped with an automatic closing device actuated by smoke density or products of combustion other than heat.

Note: The department will accept detectors installed in accordance with the Standard on Automatic Fire Detectors, NFPA No. 72-E [ILHR 51.27 (7a)].

84 WISCONSIN ADMINISTRATIVE CODE

ILHR 51

Definitions and standards

(3) RAMP SLOPE. Where there is a difference of elevation between connected areas, the difference shall be overcome by a ramp with a slope of not more than one foot in 8.

(4) PROJECTION OF ADJACENT OPENINGS. All doors and windows within 10 feet of any balcony or bridge shall be fire-resistive doors or fire-resistive windows as specified in ss. ILHR 51.047 and 51.048.

History: 1-2-56; am. (2) and (4), Register, February, 1971, No. 182, eff. 7-1-71; r. and recr. (2) and (4) eff. 8-1-71 and exp. 1-1-72, and cr. (2) and (4) eff. 1-1-72, Register, July, 1971, No. 187; am. (4) Register, June, 1972, No. 198, eff. 7-1-72; am. (4), Register, December, 1975, No. 240, eff. 1-1-76; r. and recr. Register, December, 1978, No. 276, eff. 1-1-79; am. (1) and (3), r. (2) (a) 1. a., renum. (2) (a) 1. b. to (2) (a) 1. a., Register, January, 1980, No. 289, eff. 2-1-80.

FP ILHR 51.20 Fire escapes. (1) LOCATION. Every fire escape shall be so located as to lead directly to a street, alley, or open court connected with a street.

(a) Every fire escape shall be placed against a blank wall if possible. If such a location is not possible then every wall opening which is less than 6 feet distant horizontally from any tread or platform of the fire escape shall be protected by a fire-resistive window for moderate fire exposure or by a fire-resistive door as specified in ss. ILHR 51.047 and 51.048.

(2) EXITS TO FIRE ESCAPES. Every fire escape shall be accessible from a public passageway or shall be directly accessible from each occupied room. Exits to fire escapes shall be standard exit doors as specified in s. ILHR 51.15, except that doors to "A" fire escapes may be not less than 2 feet 6 inches wide.

(3) DESIGN AND FABRICATION. Each part of every fire escape (except counterweights for balanced stairways) shall be designed and constructed to carry a live load of 100 pounds per square foot of horizontal area over the entire fire escape. Each part of every fire escape shall be designed and constructed in accordance with the requirements of s. ILHR 53.50, except that the unit stresses therein specified shall be reduced by one-fourth. The minimum sections and sizes specified below shall be increased whenever necessary so that under full load the allowable unit stresses will not be exceeded.

(a) No other material than wrought iron, soft steel or medium steel shall be used for any part of a fire escape, except for weights, separators and ornaments. No bar material less than ¼ inch thick shall be used in the construction of any fire escape, except for separators, ornaments, structural shapes over 3 inches and rigidly built up treads and platforms of approved design. In the fabrication of a fire escape, all connections or joints shall be made by riveting, bolting or welding in an approved manner. All bolts or rivets, except for ornamental work, shall be not less than ⅝ inch in diameter.

(4) PLATFORMS. Each platform on an "A" fire escape shall be at least 28 inches wide; each platform on a "B" fire escape shall be at least 3 feet 4 inches wide. Such widths shall be the clear distance between stringers, measuring at the narrowest point. Each platform shall extend at least 4 inches beyond the jambs of exit opening. The above minimum widths and lengths shall be increased, wherever necessary, so that no exit door or window will, when open, block any part of the required width of the fire escape. Every platform shall consist of either,

DEPT. OF INDUSTRY, LABOR & HUMAN RELATIONS 85
Definitions and standards ILHR 51

(a) Flat bars on edge, not less than 1 x ¼ inch, but not less than 1½ x ¼ inch where bolts and separators are used except that platforms and treads constructed of flat bars on edge may be made of material 3/16 inch in thickness provided the material is galvanized after fabrication. Bars shall not be spaced more than 1½ inches, center to center.

(b) ½ inch or ⅝ inch square bars with sharp edge up, not more than 1½ inches, center to center.

(c) ⅝ inch round bars, not more than 1½ inches, center to center.

(d) Platform and treads may be solid if covered by a roof.

(e) The platform frame shall consist of not less than 2 x ¾ inch flat bars on edge or equivalent, provided the brackets are not more than 4 feet apart. If brackets are more than 4 feet apart, the frame shall be correspondingly stronger and stiffer. Every platform wider than 30 inches, if made of square or round bars, shall have a third frame bar through the center; if made of flat bars, the platform shall have separators and bolts through the center. Frame bars shall not project more than ¼ inch above platform bars, except around the outside of platform.

(f) There shall be a platform at each story above the first, and intermediate platforms if floors are more than 18 feet apart vertically.

(g) Platforms shall not be more than 8 inches below the door sill.

(5) BRACKETS. Brackets for a 28 inch or 30 inch platform, when spaced not more than 4 feet apart, shall be made of not less than ¾ inch square bars or 1½ x 1½ x ¼ inch angles; such bars or angles shall be larger if the platform is wider or if the brackets are farther apart. Each bracket shall be fastened at the top to the wall by a through bolt (at least ¾ inch diameter), nut, and washer (at least 4 inch diameter). The slope of the lower bracket bar shall be not less than 30° with the horizontal. The lower bar shall have a washer or shoulder to give sufficient bearing against the wall.

(a) The strength of the wall to which brackets are to be attached shall be carefully considered in determining the spacing, shape and inside connection of brackets, so that under full load the wall will not be unduly strained. Where it is necessary to install brackets adjacent to wall openings they shall be located at a suitable distance therefrom, or the wall shall be properly reinforced.

(6) STAIRWAYS. (a) Each stairway of an "A" fire escape shall be at least 24 inches wide between stringers; such stairway shall have a uniform rise of not more than 8 inches and a uniform run of not less than 8 inches.

(b) Each stairway of a "B" fire escape shall be at least 3 feet 4 inches wide between stringers; such stairway shall have a uniform rise of not more than 8 inches, and a uniform run of not less than 9 inches.

1. The rise is the vertical distance from the extreme edge of any step to the corresponding extreme edge of the next step. The run is the horizontal distance between the same points.

(c) Stairway stringers shall consist of either:

1. A 5 inch channel or larger.

2. Two angles 2 x 2 x ¼ inch or larger.

51.20

86

WISCONSIN ADMINISTRATIVE CODE

ILHR 51

Definitions and standards

3. Two flat bars 2 x $\frac{3}{8}$ inch or larger.

4. One flat bar 6 x $\frac{1}{4}$ inch or larger.

5. If 2 angles or 2 flat bars are used, they shall be properly tied together by lattice bars, vertical as well as horizontal. If flat bars are used, every stairway of more than 10 risers shall have lateral bracing. The connection of stringers to platform, at top and bottom, shall be at least equal in strength to the stringers and shall safely carry the full live and dead loads. If stringers are carried by intermediate brackets, the stringers shall have a horizontal bearing on the brackets and shall be properly and securely connected thereto.

6. Treads shall consist of either flat or square bars, (not round), of the size and spacing specified for platforms. An "A" tread shall consist of at least 6 square bars, or 7 flat bars. A "B" tread shall consist of at least 7 square bars, or 8 flat bars. A "B" tread made of flat bars shall have separators and bolt through the center. A "B" tread made of square bars shall be trussed.

7. Treads and platforms may be solid if covered by a roof.

(7) BALANCED STAIRWAY. All "B" fire escapes, and all fire escapes on schools, theaters, assembly halls, hospitals, nursing homes, residential care institutions, group foster homes, and homes for the elderly either shall reach to the ground or shall have a balanced stairway reaching to the ground. "A" fire escapes which are not on schools, theaters, assembly halls, hospitals, nursing homes, residential care institutions, group foster homes and homes for the elderly may terminate in a platform at least 3 feet long, located not more than 10 feet above the ground and does not serve more than 8 persons.

(8) RAILINGS. A railing at least 42 inches in height measuring vertically from the floor of the platform, shall be provided on all open sides of platforms. Railings at least 36 inches in height, measuring vertically from the nose of the treads, shall be provided on the open sides of all stairways and on both sides of balanced stairways. Either a railing or a handrail fastened to the wall shall be provided on each side of all "B" fire escape stairways. Railings on fire escapes subject to use by children shall have intermediate rails or an ornamental pattern designed to prevent the passage of an object with a diameter larger than 9 inches. Railings on fire escapes not subject to use by children shall be provided with 2 uniformly spaced intermediate rails.

(a) Every railing shall have posts, not more than 5 feet apart made of not less than $1\frac{1}{2}$ x $1\frac{1}{2}$ x $\frac{1}{4}$ inch angles or tees, or $\frac{1}{4}$ inch pipe; top rail not less than $1\frac{1}{4}$ x $1\frac{1}{4}$ x $\frac{1}{4}$ inch angle or equivalent; center rail not less than $1\frac{1}{4}$ x $\frac{5}{16}$ flat bar or equivalent. All connections shall be such as to make the railing stiff; 2 bolts ($\frac{3}{8}$ inch or larger) shall be used at the foot of each post wherever possible, or at least one $\frac{1}{2}$ inch bolt shall be used. Railing shall be continuous. No projections on the inside of the railing shall be permitted. Where a railing returns to the wall, it shall be fastened thereto with a through bolt (at least $\frac{3}{8}$ inch diameter), nut, and washer; or (in reinforced concrete) with an approved insert; or the railing shall be made equally secure with a diagonal brace extending at least 3 feet horizontally and 3 feet vertically.

51.21

DEPT. OF INDUSTRY, LABOR & HUMAN RELATIONS 87
Definitions and standards ILHR 51

(b) All outside railings which are more than 60 feet above grade shall be at least 6 feet high, measuring vertically from floor of platform or from nose of step. Such railings shall be of special design approved by the department, having not less than 4 longitudinal rails, and vertical lattice bars not more than 8 inches apart, and proper stiffening braces or brackets.

(9) LADDER TO ROOF. Every fire escape which extends higher than the second floor shall be provided with a ladder leading from the upper platform to the roof, unless the fire escape stairway leads to the roof. The ladder shall have stringers not less than 1¼ inch pipe, or not less than 2 x ¾ inch flat bars, at least 17 inches apart in the clear. The rungs shall be not less than ½ inch square or ¾ inch round bars, 14 inches center to center. The stringers shall be securely tied together at intervals no greater than every fifth rung. The stringers of each ladder shall extend not less than 4 feet above the roof coping and return to within 2 feet of the roof, with the top rung of the ladder level with the coping.

(10) OTHER TYPES OF FIRE ESCAPES. Sliding or chute fire escapes may be used, upon the approval of the department of industry, labor and human relations, in place of "A" or "B" fire escapes. Every sliding fire escape shall be provided with a ladder constructed as in sub. (9), extending from 5 feet above grade, to 4 feet above the roof coping.

History: 1-2-56; am. Register, December, 1962, No. 84, eff. 1-1-63; am. (1) (a), Register, February, 1971, No. 182, eff. 7-1-71; am. (7), Register, February, 1971, No. 182, eff. 3-1-71; r. and recr. 51.20 (1) (a) eff. 8-1-71 and exp. 1-1-72 and cr. (1) (a) eff. 1-1-72, Register, July, 1971, No. 187; am. (1) (a), Register, June, 1972, No. 198, eff. 7-1-72; am. (3) (intro. par.), Register, December, 1974, No. 228, eff. 1-1-75; am. (1) (a), Register, December, 1975, No. 240, eff. 1-1-76; am. (8) (intro.), Register, January, 1980, No. 289, eff. 2-1-80; am. (8) (b), Register, December, 1981, No. 312, eff. 1-1-82.

MEANS OF EGRESS
Ch. ILHR 54
FACTORIES, OFFICE AND MERCANTILE BUILDINGS

ILHR 54.02 Number and location of exits. (1) NUMBER OF EXITS. Every building and every floor level thereof shall have at least 2 exits.

(2) **EXCEPTIONS.** One exit will be permitted in the following conditions:

(a) Floor levels used entirely for storage in buildings 2 stories or less in height and not over 3,000 square feet gross area per floor.

(b) Interior balconies or mezzanine floors not over 3,000 square feet gross area used entirely for storage.

(c) Open interior balconies or open mezzanine floors not over 750 square feet gross area used for purposes other than nonoccupied storage.

(d) One-story office buildings, without a basement or mezzanine, having a gross floor area, per floor, of not more than 1,800 square feet. Only one office operation per floor level shall be permitted. The single exit from the first floor or ground floor(s) shall be an outside exit serving only that floor level.

(e) Retail establishments not over 750 square feet net area, provided there are 2 directions for exiting from the entrance door of the store.

192 WISCONSIN ADMINISTRATIVE CODE

ILHR 54

Factories, office, mercantile

(3) **OFFICE SUITE EXITING.** One exit will be permitted from office suites having a floor area of not more than 1,800 square feet net area, provided there are 2 directions for exiting from the entrance door of the suite.

(4)* **EXIT DISTANCE.** (a) Exits shall be distributed or located so that no part of any building within the scope of this chapter will be more than 150 feet distant from an exit.

(b) Where an approved automatic fire sprinkler system is provided throughout the building, an increase in exit distance to 200 feet will be permitted for mercantile buildings and an increase in exit distance to 300 feet will be permitted in all other buildings within the scope of this chapter, except high hazard buildings.

(c) Buildings having contents which are liable to burn with extreme rapidity or from which poisonous fumes may be liberated or explosions occur in case of fire, shall have exits provided so that the maximum distance to exit is limited to 75 feet.

Note: See s. A52.015 of Appendix A for further information relating to "high hazard" occupancies.

(d) All of the above distances shall be measured along public passageways and aisles.

Note: Also see s. ILHR 54.08 (1) for alternate exit distance provisions.

(5) **EXIT DISTRIBUTION.** Exits in all buildings of this classification shall be so located and distributed so as to afford the best possible egress.

History: 1-2-56; cr. (1) (c), Register, September, 1959, No. 45, eff. 10-1-59; am. (1) (b), Register, February, 1971, No. 182, eff. 7-1-71; r. and recr. (1) (b) eff. 8-1-71 and exp. 1-1-72, and cr. (1) (b) eff. 1-1-72, Register, July, 1971, No. 187; am. (1), Register, September, 1973, No. 213, eff. 10-1-73; r. and recr. Register, December, 1978, No. 276, eff. 1-1-79; am. (4), Register, January, 1980, No. 289, eff. 2-1-80; am. (4), Register, December, 1981, No. 312, eff. 1-1-82; emerg. am. (4) (b), eff. 9-6-86; am. (4) (b), Register, November, 1986, No. 371, eff. 12-1-86.

ILHR 54.03 Type of exits. (1) At least one-half of the exits required in accordance with s. ILHR 54.02 shall be stairways or standard exits to grade as specified in ss. ILHR 51.15-51.18. The other exits shall be either stairways, standard exits, or horizontal exits as specified in s. ILHR 51.19, or fire escapes as specified in s. ILHR 51.20. A fire escape will not be accepted as a required exit for any building level more than 5 stories or 55 feet above grade. An outside wooden stairway may be used as an exit for a 2-story building.

(a) *Exception.* The width of required exit stairways serving unoccupied areas (i.e., storage areas, equipment mezzanines and similar areas) not exceeding 750 square feet may be reduced to 3 feet 0 inches.

(b) *Exception.* Less than 3 risers may be used to elevated work stations (such as pharmacy floors, computer floors and similar areas) or to altars, podiums and similar areas, not in a required exit passageway.

(c) *Exception.* A spiral stairway may be used as a nonrequired convenience stairway in addition to all other required exit stairways in places of employment.

*See Appendix A for further explanatory material.

INDUSTRY, LABOR AND HUMAN RELATIONS 192-1
Factories, office, mercantile ILHR 54

(d) *Exception.* A rescue platform (exterior balcony) of combustible construction may be used as a required second exit for buildings of type 7 and 8 construction, provided the following conditions are satisfied:

1. The exit serves 8 or less people;
2. The exit platform is located not more than 10 feet above the adjacent exit discharge grade;
3. The platform area is at least 14 square feet, with a minimum dimension of 3 feet;
4. The platform is designed for 80 pounds per square foot live load plus dead load;
5. Railings are provided in accordance with the provisions of s. ILHR 51.162;
6. Platforms having solid floors are provided with a roof equal in area to that of the platform; and
7. All wood used in the construction of the rescue platform shall be pressure treated wood satisfying the requirements of the applicable standards specified in s. ILHR 51.27 (6a) unless the wood is inherently resistant to decay.

(2) Every building which will accommodate more than 50 persons above the second story shall have at least 2 stairways.

(3) Wherever stairways are required under this classification, ramps with a slope not greater than one foot in 8 feet may be substituted. Ramps shall comply with all the requirements for stairways as to construction, enclosures, width, landing and lighting, and shall be surfaced with an approved non-slip material.

History: 1-2-56; am. (1), Register, December, 1974, No. 228, eff. 1-1-75; cr. (1) (a) to (d), Register, December, 1977, No. 264, eff. 1-1-78; am. (1) (b), Register, December, 1978, No.

DEPT. OF INDUSTRY, LABOR AND HUMAN RELATIONS 193
Factories, office, mercantile ILHR 54

276, eff. 1-1-79; am. (1) (d) 5. and (3), Register, January, 1980, No. 289, eff. 2-1-80; am. (1) (d) (intro.) 5. and 6., cr. (1) (d) 7., Register, December, 1983, No. 336, eff. 1-1-84.

ILHR 54.04 Required exit width. (1) The total required exit width from a building level shall be in accordance with the requirements of ss. ILHR 51.15 (6) and 51.16 (3). **FP**

(2) Standard fire escapes (s. ILHR 51.20) may be substituted for stairways to the extent of not more than 1/3 of the required total width, subject to the provision of s. ILHR 54.02.

(3) Horizontal exits in accordance with the requirements of s. ILHR 51.19 may provide up to one-half of the required exit width for any floor, subject to the provisions of s. ILHR 54.02.

History: 1-2-56; am. (1) (a) and (b) and (3) (a) and (b), Register, June, 1972, No. 198, eff. 1-1-73; r. and recr. (1) and (3), r. (4), Register, December, 1974, No. 228, eff. 1-1-75.

ILHR 54.05 Capacity of buildings. (1) In calculating the aggregate width of exits, the capacity of the buildings shall be established as follows:

- (a) Stores, first floor and basement _____ 30 sq. ft. per person
- (b) Stores, second floor and above _____ 60 sq. ft. per person
- (c) Dining rooms, cafes, taverns, etc. _____ 10 sq. ft. per person
- (d) Places of seated assemblage _____ 7 sq. ft. per person
- (e) Warehouses _____ 300 sq. ft. per person
- (f) Factories and offices _____ 75 sq. ft. per person

(2) The above figures are based on the net area of each occupied space. Where dining rooms, cafes, dance halls and places of seated assemblage accommodate more than 100 persons, see s. ILHR 55.01.

(3) In other occupancies not specified above, the capacity shall be determined by the actual number of persons liable to be accommodated therein and no greater number of persons will be permitted therein.

ILHR 54.06 Exit doors. (1) **GENERAL.** Except as provided in pars. (a) and (b), every door which serves as an exit from a building, public passageway or stairway shall be a standard exit door as specified in s. ILHR 51.15. **FP**

(a) Exit doors serving 25 or less persons need not swing in the direction of egress.

(b) Exit access doors serving 25 or less persons may be reduced in width to 2 feet 8 inches and may be sliding or accordian-type doors.

(2) **ILLUMINATED EXIT SIGNS.** Every exit door from each floor, other than the principal entrance on the first floor, shall be marked with exit signs as specified in s. ILHR 51.15 (5).

History: 1-2-56; am. (1), Register, December, 1978, No. 276, eff. 1-1-79; am. Register, January, 1980, No. 289, eff. 2-1-80; am. Register, December, 1983, No. 336, eff. 1-1-84.

ILHR 54.07 Passageways. Where there is not direct access to outside exit doors, safe and continuous passageways, aisles or corridors leading directly to every exit shall be maintained at all times on all floors of all **FP**

54.07

194 WISCONSIN ADMINISTRATIVE CODE

ILHR 54

Factories, office, mercantile

buildings. Every passageway, aisle or corridor shall conform in width to the rule for width of stairways as specified in ss. ILHR 51.15 (6) and 51.16 (3). Widths shall be measured in the clear, at their narrowest points produced by any projection, radiator, pipe or other object and the required width shall be maintained clear and unobstructed at all times.

History: 1-2-56; am. Register, December, 1981, No. 312, eff. 1-1-82.

FP ILHR 54.08 Enclosure of stairways and shafts. (1) (a) Except as provided in par. (b), all stairways including landings, ramps and shafts, shall be enclosed as specified in s. ILHR 51.02 (11).

(b) 1. The stairways or shafts connecting the first floor with one floor level immediately adjacent to it (e.g., second story, mezzanine, ground floor or basement) may be left open in buildings 2 stories or less in height, and where the distance to an exit from the area served by the open stairway including the horizontal travel distance on the exit access stair, does not exceed 100 feet in buildings not completely protected by an approved automatic sprinkler system or 150 feet in buildings completely protected by an approved automatic sprinkler system; or

2. Any stairway or shaft connecting the second floor, first floor and basement or ground floor shall be separated at the first floor level or first adjacent basement or ground floor level with fire resistive construction as specified in Table 51.03-A or better in buildings 2 stories or less in height, and where the distance to an exit from the area served by the open stairway including the horizontal travel distance on the exit access stair, does not exceed 100 feet in buildings not completely protected by an approved automatic sprinkler system or 150 feet in buildings completely protected by an approved automatic sprinkler system.

(2) All doors opening into such enclosures shall be as specified in s. ILHR 51.047, and all windows shall be of wired glass and metal frames and sash.

Note: See ch. Ind 4 for requirements governing the installation and operation of elevators.

History: 1-2-56; am. (1) (a), (b), (c), (d) and (2), Register, February, 1971, No. 182, eff. 7-1-71; r. and recr. (1) (a), (b), (c), (d) and (2) eff. 8-1-71 and exp. 1-1-72; cr. (1) (a), (b), (c), (d) and (2) eff. 1-1-72, Register, July, 1971, No. 187; r. and recr. (1), Register, June, 1972, No. 198, eff. 1-1-73; am. (3), Register, December, 1977, No. 264, eff. 1-1-78; r. (3), Register, December, 1978, No. 276, eff. 1-1-79; am. (1), Register, January, 1980, No. 289, eff. 2-1-80; am. (1), Register, October, 1982, No. 322, eff. 11-1-82; am. (1) (b), Register, December, 1983, No. 336, eff. 1-1-84.

MEANS OF EGRESS
Ch. ILHR 55
THEATERS AND ASSEMBLY HALLS

ILHR 55.06 Capacity. (1) The following table includes various types of occupancy within the scope of this section, together with the method to be used in determining the capacity.

(2) No greater number of persons than the number thus established shall be permitted in any theater or assembly hall.

Use or Occupancy	Basis of Capacity
(a) Arenas and field houses.....	4 sq. ft. per person. Use seated areas only.
(b) Assembly halls, with stage.....	7 sq. ft. per person.
(c) Banquet halls.....	10 sq. ft. per person.
(d) Churches (auditoriums).....	7 sq. ft. per person.
(e) Churches(dining rooms).....	10 sq. ft. per person.
(f) Dance halls.....	10 sq. ft. per person.
(g) Dining rooms.....	10 sq. ft. per person.
(h) Gymnasiums.....	6 sq. ft. per person for seated space. 15 sq. ft. per person for unseated space.
(i) Lecture halls.....	7 sq. ft. per person.
(j) Lodge halls.....	6 sq. ft. per person for seated space. 15 sq. ft. per person for unseated space.
(k) Skating rinks.....	45 sq. ft. per person.
(l) Theaters.....	7 sq. ft. per person.
(m) Theater lobbies.....	7 sq. ft. per person.

(3) The capacity of theaters and theater lobbies must be combined to determine the theater capacity.

(4) (a) Every theater or assembly hall having movable seats shall display a sign stating the maximum number of persons permitted by code.

1. The sign shall be placed in a conspicuous place at the main entrance to each theater or assembly hall.

2. The sign shall have the following wording: "Limit (Number) Persons." The maximum number of persons shall be determined by the capacity as permitted by sub. (2) and s. ILHR 55.12. The lettering shall be

55.06

208 WISCONSIN ADMINISTRATIVE CODE

ILHR 55

Theaters, assembly halls

white on a dark background. The letters shall be not less than 1½ inches in height and the number shall be not less than 3 inches in height.

History: 1-2-56; cr. (4) (a), Register, July, 1966, No. 127, eff. 8-1-66; r. (2) (k), renum. (2) (1) (m) (n) to be (k) (1) and (m), Register, September, 1973, No. 213, eff. 10-1-73; am. (2)(k), Register, December, 1981, No. 312, eff. 1-1-82.

FP ILHR 55.07 Number and location of exits. (1) (a) Except as provided in par. (b), every floor and balcony of a theater and assembly hall shall be provided with not less than 2 exits, placed as far apart as practicable and so located that if any exit is blocked, some other exit will still be available from every part.

(b) A balcony accommodating not more than 30 persons in places of worship may be served by one exit.

(2) Where more than 600 persons are accommodated, there shall be at least 3 exits and where more than 1,000 persons are accommodated, there shall be at least 4 exits.

(3) Exits shall be distributed on all sides which adjoin streets, alleys or open courts.

History: 1-2-56; r. and recr. (1), Register, August, 1985, No. 356, eff. 1-1-86.

FP ILHR 55.08 Type of exits. (1) The required exits from any part of a theater or assembly hall shall be exit doorways, stairways or ramps.

(2) All exits to grade from a higher or lower level shall be stairways or approved ramps. In all theaters and in assembly halls having a capacity of more than 400 persons, where the exit rise is not more than 3 feet approved ramps shall be used. By approved ramp is meant an incline located inside the building and having a slope of not more than one foot of rise in 8 feet.

(3) Stairway exits shall be interior stairways, or smokeproof towers as specified in s. ILHR 51.17; except that "B" type fire escapes may be used as exits from balconies for not more than one-half the required exit width, if located against blank walls.

FP ILHR 55.09 Stairways. (1) Every stairway in a theater or assembly hall shall be enclosed as specified in s. ILHR 51.18 with the following exceptions:

(a) Monumental stairways from the main floor to the first balcony need not be enclosed provided the balcony is served by additional enclosed stairways as specified in ss. ILHR 51.02 (11) and 55.07.

(b) 1. In a place of worship, a monumental exit access stairway from the main floor to the first balcony having an occupant load of not more than 30 persons need not be enclosed.

2. In a place of worship, a monumental exit access stairway from the main floor to the first balcony having an occupant load of 31 to 100 persons need not be enclosed provided the balcony is served by an additional open stairway.

3. In a place of worship, stairways from the main floor to the first balcony having an occupant load greater than 100 persons shall be enclosed to the outside as specified in ss. ILHR 51.02 (11) and 51.18.

Register, August, 1985, No. 356

DEPT. OF INDUSTRY, LABOR & HUMAN RELATIONS 209
Theaters, assembly halls ILHR 55

4. Stairways from the basement to the first floor of a single story place of worship need not be enclosed if they lead directly to the exits.

(2) Stairways and steps which have more than 3 risers shall have hand-rails on both sides.

(3) (a) Every stairway used by the public in a theater or assembly hall shall have a uniform rise of not more than 7½ inches and a uniform tread of not less than 10 inches, measuring from tread to tread and from riser to riser.

(b) Less than 3 risers may be used to elevated altars, podiums and similar areas in churches provided the elevated area is not part of a required exit passageway.

Note. See s. ILHR 51.16 for general stairway requirements.

History: 1-2-56; am. Register, January, 1961, No. 61, eff. 2-1-61; r. and recr. Register, February, 1968, No. 146, eff. 3-1-68; am. (4), Register, February, 1971, No. 182, eff. 7-1-71; am. (2), Register, December, 1974, No. 228, eff. 1-1-75; am. (1) (intro.) and cr. (4) (a), Register, December, 1978, No. 276, eff. 1-1-79; am. (1) (a), Register, December, 1981, No. 312, eff. 1-1-82; r. and recr. (1) (b), Register, October, 1982, No. 322, eff. 11-1-82; r. (2), renum. (3) and (4) to be (2) and (3) and am. (3) Register, August, 1985, No. 356, eff. 1-1-86.

ILHR 55.10 Exit doorways and doors. (1) Every required single exit doorway shall contain a standard exit door as specified in s. ILHR 51.15. For double doors, with or without mullions, the width of each door may be reduced to 2 feet 6 inches. **FP**

(2) No single door or leaf of a double door, shall be more than 3 feet 6 inches wide, and no 2 doors shall be hinged together.

(3) No rolling, sliding or revolving door shall be counted as an exit from any theater or assembly hall, nor shall any such door be permitted where it would be liable to be used by the public as an exit.

(4) Sills at all exit doorways shall be level and flush with adjacent inside and outside floors and ramps. Where an aisle or passageway leads to an exit from either side of the exit doorway there shall be a level floor space at the doorway extending the width of the aisle and the doorway.

History: 1-2-56; am. (4), Register, August, 1985, No. 356, eff. 1-1-86.

ILHR 55.11 Exit lights. All required exits, except those in church auditoriums, shall be identified by an approved exit light. Directional exit lights shall be provided to direct occupants to the exits. Exit lights and directional exit lights shall be as specified in s. ILHR 51.15 (5). **FP**

History: 1-2-56; r. and recr. Register, December, 1983, No. 336, eff. 1-1-84.

ILHR 55.12 Required exit width. (1) The total required exit width from a building level shall be in accordance with the requirements of ss. ILHR 51.15 (6) and 51.16(3). **FP**

(2) In theaters, the width of the front entrance shall be not less than ½ of the total required exit width.

History: 1-2-56; am. (1), Register, June, 1972, No. 198, eff. 1-1-73; am. (1), Register, December, 1974, No. 228, eff. 1-1-75.

Register, August, 1985, No. 356

55.13

210 WISCONSIN ADMINISTRATIVE CODE

ILHR 55

Theaters, assembly halls

ILHR 55.13 Seating. All chairs, seats and benches used for the purpose of assembly seating shall conform to the requirements of subch. V, Assembly Seating Facilities, of ch. ILHR 62.

History: 1-2-56; am. Register, January, 1961, No. 61, eff. 2-1-61; r. (2), renum. (3) to (6) to be (2) to (5), Register, January, 1980, No. 289, eff. 2-1-80; r. and recr., Register, December, 1981, No. 312, eff. 1-1-82.

FP ILHR 55.14 Width of aisles. (1) Aisles having seats on both sides shall not be less than 2 feet 10 inches wide at the beginning and shall increase in width toward the exits at the rate of $\frac{1}{4}$ inch per foot of run; or the aisle may have a uniform width not less than the average width of the foregoing calculation. No wall aisle shall be less than 3 feet wide and no other straight aisle shall be less than 3 feet 6 inches wide.

(2) There shall be a cross aisle leading to each required side exit. Cross aisles shall not be less than 6 feet 8 inches back to back of adjacent rows of seats.

FP ILHR 55.15 Lobbies and foyers. The width of lobbies and foyers shall be determined on the same basis as required for exits in s. ILHR 55.12, but shall in no case be less than 5 feet wide, and shall be so designed and apportioned as to prevent congestion and confusion. Lobbies and foyers which serve as means of egress shall be at least equal in combined width to the required width of the stairways, passageways, aisles or exit doorways leading to them.

ILHR 55.16 Inclines and aisle steps. (1) To overcome any difference in level between courts, corridors, lobbies, passageways or aisles required, or used, in egress from a theater or an assembly hall, approved ramps as specified in s. ILHR 55.08 shall be employed where the difference in elevation does not exceed 3 feet, except that this requirement need not apply to balconies.

(2) Steps in balcony aisles shall extend the full width of the aisle and shall have a uniform rise and run as specified in s. ILHR 55.09. No handrails will be required.

FP ILHR 55.17 Obstruction. (1) All lobbies, aisles, passageways and doorways shall be kept free from furniture, drapes, display equipment, merchandise, vending machines and other obstructions, and no person except an employe shall be allowed to stand in or occupy, any of the aisles, passageways, corridors or lobbies during any performance or public gathering. Except that patrons may be allowed to wait in a lobby or similar space if such use does not encroach upon the required clear width of the exits. Such waiting shall be restricted to areas separated from the required exit ways by fixed railings not less than 42 inches high. In entrance lobbies only, the exit space may be divided by railings not less than 36 inches high set up in the direction of travel in an approved manner for the regulation of ingress and egress.

(2) A booth or counter for the sale of package merchandise may be placed in the lobby or foyer of a theater where there is sufficient excess space so that the front of the booth or counter can be located not less than 5 feet back of the line marking the width of the lobby or foyer required for exit purposes.

MEANS OF EGRESS

Ch. ILHR 56

SCHOOLS AND OTHER PLACES OF INSTRUCTION

ILHR 56.06 Exits. (1) **TOTAL NUMBER OF EXITS.** The total number of exits from each floor level and each building shall be determined on the basis of total aggregate exit width and distances to exit. Each building and each floor level shall be provided with at least 2 exits. **FP**

(2) **TYPE OF EXITS.** At least 2 exits from all floor levels shall lead directly to grade through standard exit doors, stairs, interior enclosed stairs, smokeproof stair towers, fire-rated exit corridors, passageways, or ramps. One-half of the remaining required exits may be horizontal exits or fire escapes. Fire escapes are prohibited as required exits in pre-school, elementary, middle, and high schools. In no case will fire escapes be permitted above the second story.

(a) *Standard exit doors.* Standard exit doors shall be provided in accordance with the requirements of ss. ILHR 51.15 and 56.08.

(b) *Exit stairs.* Stairs shall conform to the requirements of s. ILHR 51.16, except that the stairs shall have a uniform rise of not more than 7½ inches, measured from tread to tread, and a uniform tread of not less than 10 inches, measured from nosing to nosing of tread. Handrails shall be provided on both sides. All stairs serving basements shall be in accordance with the requirements of s. ILHR 51.02 (11). No closets or rooms may be placed under a stairway or landing.

(c) *Interior enclosed stairs and smokeproof stair towers.* Interior stairs and smokeproof stair towers shall be constructed in accordance with the requirements of ss. ILHR 51.17 and 51.18.

(d) *Fire-rated exit corridors.* All rated exit corridors required to satisfy limitations on exit distance shall be of not less than one-hour fire-resis-

222 WISCONSIN ADMINISTRATIVE CODE

ILHR 56

Schools, places of instruction

tive construction, unless the fire-resistive ratings indicated in Table 51.03-A for required exit corridor enclosures are more restrictive.

(e) *Exit ramps.* The minimum width of exit ramps shall be determined in accordance with the requirements of s. ILHR 56.07. The minimum width shall be not less than 3 feet 8 inches. Exit ramps, other than those required for the physically disabled, shall have a slope not exceeding 1:8. Ramp slopes exceeding 1:12 shall be provided with handrails. Ramps shall be provided with a slip-resistant finish. Ramps shall be provided from areas noted under sub. (3) (c) involving a change of elevation between floor levels or platforms not exceeding 3 feet.

(f) *Fire escapes.* Fire escapes shall be constructed in accordance with the requirements of s. ILHR 51.20.

(g) *Horizontal exits.* Horizontal exits shall be constructed in accordance with the requirements of s. ILHR 51.19 and shall be of at least 4-hour rated construction.

(3) LOCATION OF EXITS. (a) *Exit distance.* 1. Travel distance to an exterior exit door, a required fire-resistive rated exit corridor, interior enclosed stairs, smokeproof stair tower, horizontal exit, or fire escape, from any point in a building accessible to the public, shall not exceed 150 feet.

2. Where an approved automatic fire sprinkler system is provided throughout the building, an increase in exit distance to 200 feet will be permitted.

3. Building service areas, including pipe chases and tunnels, catwalks, ducts or similar spaces not accessible to the public, shall not exceed 300 feet from an exit.

(b) *Distribution of exits.* All exits shall be distributed to provide the best possible means of egress. The exits shall be located so that in case any exit is blocked at any point some other exit is accessible through public passageways at all times. Locked security gates and doors shall not be placed so as to block required exit passageways or create dead-end corridors.

(c) *Auditorium, gymnasium and field house exits.* This rule shall apply only to auditoriums, gymnasiums and field houses which have a capacity exceeding 600 persons. One-half of the required exits shall discharge directly to a street, alley or open court connected with a street, unless a 2-hour rated exit corridor is provided, wide enough to accommodate one-half of the occupants, which extends from the interior wall of the auditorium, gymnasium or field house to an exterior exit. The remaining required exits shall discharge directly to the exterior or to a public passageway which permits 2 directions of travel to the exits at the exterior of the building. The exiting shall be direct and unobstructed.

(4) CLASSROOM EXITS. (a) *Exits serving 50 persons or less.* At least one exit shall be provided from all rooms serving a capacity of 50 persons or less. The exit shall discharge directly to the exterior of the building or to a public passageway which permits 2 directions of travel to the exterior.

(b) *Exits serving 51-100 persons.* At least 2 exits shall be provided from all rooms serving a capacity of 51-100 persons. One exit shall discharge directly to the exterior of the building or to a public passageway which permits 2 directions of travel to the exterior. One exit may discharge

INDUSTRY, LABOR & HUMAN RELATIONS 223
Schools, places of instruction ILHR 56

through an adjacent room provided a clear passageway is maintained from the connecting door to a required exit serving the adjacent room.

(c) *Exits serving more than 100 persons.* At least 2 exits shall be provided from all rooms serving a capacity of more than 100 persons. The exits shall discharge directly to grade or to a public passageway which permits 2 directions of travel to the exterior.

(5) **WIDTH OF EXITS.** The total required exit width shall be provided in accordance with the requirements of s. ILHR 56.07.

(6) **EXIT LIGHTS.** All required exits indicated in s. ILHR 56.06 (2), and FP exits from areas serving a capacity of more than 100 persons, shall be identified by an approved exit light. Directional exit lights shall be provided to direct occupants to an exit. Exit lights and directional exit lights shall be as specified in s. ILHR 51.15 (5).

History: 1-2-56; am. (1), cr. (1) (a), Register, September, 1959, No. 45, eff. 10-1-59; am. Register, January, 1961, No. 61, eff. 2-1-61; r. and recr. (1) (a), renum. (2) to be (3), (3) to be (4), (4) to be (5), (5) to be (6) and (6) to be (7), and cr. (2) and (8), Register, May, 1971, No. 185, eff. 6-1-71; r. and recr., Register, September, 1973, No. 213, eff. 10-1-73; am. (1) (a) 2., Register, December, 1974, No. 228, eff. 1-1-75, r. and recr. Register, December, 1975, No. 240, eff. 1-1-76; am. (2), intro. and cr. (2) (g), Register, December, 1976, No. 252, eff. 1-1-77; am. (6), Register, December, 1983, No. 336, eff. 1-1-84; emerg. am. (3) (a), eff. 9-6-86; am. (3) (a), Register, November, 1986, No. 371, eff. 12-1-86.

ILHR 56.07 Required exit width. (1) The total required exit width from FP a building level shall be in accordance with the requirements of ss. ILHR 51.15 (6) and 51.16 (3).

(2) The capacity of educational buildings or any individual story or section thereof for the purpose of determining exits shall be the maximum capacity designated on approved plans.

(a) The maximum capacity shall not exceed the requirements of par. (b).

(b) The maximum capacities of all rooms and spaces as listed below shall be determined on the basis of the minimum net square feet area per person shown for that occupancy unless otherwise designated on the plans.

	Minimum Square Feet Per Occupant
1. Academic classrooms—Regular.....	20
2. Administrative and office space.....	75
3. Arts, crafts, drafting.....	30
4. Bleachers (one seat per 18 inches of bench length)	
5. Gymnasiums, field houses, auditoriums, theatres, lecture rooms (fixed seating).....	6
6. Gymnasiums, field houses, multipurpose rooms, cafeterias, study halls, commons and other level floor areas with nonfixed individual seating.....	10
7. Home economics, business education.....	30
8. Industrial arts-vocational shop.....	50
9. Laboratories—Science (fixed lab. tables).....	30
10. Libraries and resource centers.....	20
11. Museums and art galleries.....	40
12. Music	
a. Vocal.....	10
b. Instrumental.....	20
13. Special education	
a. Mentally retarded, physically handicapped, etc.....	35

History: 1-2-56; r. and recr. (3), Register, May, 1971, No. 185, eff. 6-1-71; am. (1), Register, June, 1972, No. 198, eff. 1-1-73; r. and recr., Register, September, 1973, No. 213, eff. 10-1-73;

Register, November, 1986, No. 371

56.07

224 WISCONSIN ADMINISTRATIVE CODE

ILHR 56

Schools, places of instruction

r. and recr. (1), r. (2), (3) and (4), renum. (5) to be (2), Register, December, 1974, No. 228, eff. 1-1-75.

ILHR 56.08 Exit doors. (1) STANDARD EXIT DOORS. Exit doors shall comply with the requirements of s. ILHR 51.15. The aggregate width of exit doors shall be as required in s. ILHR 56.07. No single door or leaf of a double door shall be more than 42 inches wide.

(2) CLASSROOM EXIT DOOR WIDTH AND SWING. (a) *Classroom doors serving 50 persons or less.* Classroom doors serving classrooms with a capacity of 50 persons or less shall be not less than 3 feet 0 inches in width. The doors may swing into the classroom.

(b) *Classroom doors serving more than 50 persons.* Classroom doors serving classrooms with a capacity of more than 50 persons shall be standard exit doors and shall swing outward toward the means of egress.

(3) ALL OTHER EXIT DOORS. Doors serving areas other than classrooms shall comply with s. ILHR 54.06.

History: 1-2-56; r. and recr. Register, December, 1975, No. 240, eff. 1-1-76; am. (2) and cr. (3), Register, December, 1978, No. 276, eff. 1-1-79; am. (1) and (2) (b), r. (2) (c), Register, January, 1980, No. 289, eff. 2-1-80.

FP ILHR 56.09 Passageways. (1) The minimum unobstructed width of corridors and passageways which are used by the public or by the occupants generally, shall be determined in the same manner as specified for stairways in s. ILHR 56.07, but in no case shall this width be less than 4 feet. Corridors and passageways serving as a means of egress shall be at least equal in combined width to the required width of the stairways or passageways leading to them.

History: 1-2-56; r. (1) and renum. (2) to be (1), Register, May, 1971, No. 185, eff. 6-1-71.

ILHR 56.13 Assembly seating. All assembly seating in auditoriums, gymnasiums, field houses and other large group occupancy areas shall comply with the requirements of subch. V, Assembly Seating Facilities, of ch. ILHR 62. Where any area of a building in this category has a stage loft in excess of 25 feet 0 inches in height above the stage floor and is equipped with permanent or movable scenery, it shall comply with ss. ILHR 55.21 through 55.30.

History: 1-2-56; r. and recr., Register, May, 1971, No. 185, eff. 6-1-71; r. and recr., Register, December, 1981, No. 312, eff. 1-1-82.

ILHR 56.14 Seats, desks and aisles. (1) Seats, desks, tables and other loose equipment need not be fastened to the floor or to each other provided that any seating arrangement use, will maintain during occupancy, free and unobstructed intermediate, cross and wall aisles leading to the exit.

(a) Stepped floors or tiered platforms shall be no less than 48 inches in width to permit the above arrangement.

(b) Seats, desks, tables and other loose equipment used in instructional occupancies shall be of a durable type of construction to assure safety and stability.

History: 1-2-56; r. and recr., Register, May, 1971, No. 185, eff. 6-1-71.

MEANS OF EGRESS

Ch. ILHR 57

RESIDENTIAL OCCUPANCIES

INDUSTRY, LABOR & HUMAN RELATIONS 237
Residential occupancies ILHR 57

ILHR 57.03 Number and location of exits. (1) NUMBER OF EXITS. (a) Except as provided in par. (b), there shall be at least 2 directions of travel from each living unit door by means of exits to grade, stairways, interior enclosed stairways, ramps, fire escapes or horizontal exits.

(b) Living units may have 2 exits or 2 exit access doors having only one direction of travel provided the exit access doors lead to separate exits.

(c) A minimum of 2 exits or exit access doors shall be provided from any living unit which accommodates more than 8 people.

(2) DISTANCE TO EXIT. (a) 1. Exits shall be distributed so that the entrance to each living unit will be not more than 100 feet distant from an exit, measuring along public passageways.

Note: Also see s. ILHR 57.08 (2).

2. Where automatic fire sprinkler system protection as specified in option 2 of s. ILHR 57.016 (1) (b) is provided an increase in exit distance to 150 feet will be permitted.

(b) The exit distances required by this section shall be measured to exits to grade, to doors leading to stairway enclosures as specified in ss. ILHR 51.165, 51.17 and 51.18, or to horizontal exits as specified in s. ILHR 51.19.

(3) EXIT DISTRIBUTION. The number and location of exits shall be such that in case any exit or passageway is blocked at any point, some other exit will still be accessible through public passageways from every living unit.

(4) DIRECTIONS FOR ESCAPE. A notice shall be conspicuously posted in every habitable room to be used by transients giving complete and plain directions for reaching at least 2 exits.

(5) EXITS FOR NONRESIDENTIAL PORTIONS OF BUILDINGS. Exits serving portions of buildings without sleeping rooms or living units (i.e., basements of apartment buildings, hotel lobbies, and similar areas) shall be as specified in ss. ILHR 54.02 to 54.07.

History: Cr. Register, December, 1981, No. 312, eff. 1-1-82; am. (1), Register, August, 1985, No. 356, eff. 1-1-86; emerg. renum. (2) (a) to be (2) (a) 1., cr. (2) (a) 2., eff. 9-6-86; renum. (2) (a) to be (2) (a) 1., cr. (2) (a) 2., Register, November, 1986, No. 371, eff. 12-1-86.

ILHR 57.04 Capacity of buildings and exits. (1) BUILDINGS. (a) *Sleeping areas.* The capacity of the habitable rooms of the living units of the building, other than a community-based residential facility, shall be established as follows:

- 1. 400 cubic feet for each occupant over 12 years of age; and
- 2. 200 cubic feet for each occupant 12 years of age or under.

(b) *Minimum size.* The size of habitable rooms shall provide the minimum volumes specified in par. (a).

(c) *Nonsleeping areas.* The capacity of the areas not within the living units of the building shall be established as specified in s. ILHR 54.05 or 55.06.

(d) *Overcrowding.* The number of occupants permitted in any room or in the building shall not exceed the capacities specified in this section.

238 WISCONSIN ADMINISTRATIVE CODE

ILHR 57

Residential occupancies

(2) **COMMUNITY-BASED RESIDENTIAL FACILITIES.** (a) *Facilities serving 9 to 20 residents.* The minimum size of resident bedrooms in community-based residential facilities serving 9 to 20 residents shall be as follows:

1. Sixty square feet of habitable floor space per ambulatory resident;
2. Eighty square feet of habitable floor space per semiambulatory or nonambulatory resident in multiple bed sleeping rooms; and
3. One hundred square feet of habitable floor space per semiambulatory or nonambulatory resident in single bed sleeping room.

(b) *Facilities serving more than 20 residents.* The minimum size of resident bedrooms in community-based residential facilities serving more than 20 residents shall be as follows:

1. Eighty square feet of habitable floor space per ambulatory resident;
2. Eighty square feet of habitable floor space per semiambulatory and nonambulatory resident in multiple bed sleeping rooms; and
3. One hundred square feet of habitable floor space per semiambulatory and nonambulatory resident in single bed sleeping rooms.

(3) **EXITS.** The total required exit width from each level of the building shall be as specified in ss. ILHR 51.15 (6) and 51.16 (3).

History: Cr. Register, December, 1981, No. 312, eff. 1-1-82.

FP ILHR 57.05 Type of exits. (1) **GENERAL.** Except as provided in sub. (2), at least one-half of the required exits, accessible from each living unit, shall be exits to grade or stairways as specified in ss. ILHR 51.15 and 51.16. The remaining exits shall be either stairways, interior enclosed stairways, exits to grade or horizontal exits. Fire escapes placed against blank walls may be used as exits from floors which are not more than 40 feet above grade.

(2) **EXCEPTIONS.** (a) Every building which accommodates more than one family, or 8 persons, above the second story shall have at least 2 stairways.

(b) A rescue platform (exterior balcony) of combustible construction may be used as a required second exit for 3-story buildings of type 5 through type 7 construction or 2-story buildings of type 8 construction, provided the following conditions are satisfied:

1. The exit serves a single living unit;
2. The exit platform is located not more than 10 feet above the adjacent exit discharge grade;
3. The platform area is at least 14 square feet, with a minimum dimension of 3 feet;
4. The platform is designed for 80 pounds per square foot live load plus dead load;
5. Railings are provided as specified in s. ILHR 51.162;
6. Platforms having solid floors are provided with a roof equal in area to that of the platform;

INDUSTRY, LABOR & HUMAN RELATIONS 239
Residential occupancies ILHR 57

7. All wood used in the construction of the rescue platform shall be pressure treated wood satisfying the requirements of the applicable standards specified in s. ILHR 51.27 (6a) unless the wood is inherently resistant to decay; and

8. The building is not a residential care facility, group foster home or home for the elderly.

History: Cr. Register, December, 1981, No. 312, eff. 1-1-82; am. (2) (b) (intro.) and 6., renum. (2) (b) 7. to be (2) (b) 8., cr. (2) (b) 7., Register, December, 1983, No. 336, eff. 1-1-84.

ILHR 57.06 Doors. (1) EXIT DOORS. (a) *General*. Except as provided in par. (b), exit doors shall be as specified in s. ILHR 51.15.

(b) *Exception*. 1. Sliding glazed patio-type doors may serve as the second exit from individual living units. A means to prevent accumulation of snow and ice in the door track or freezing of the door shall be provided.

2. A door which is used by not more than 25 persons is not required to swing in the direction of egress.

(2) OPENINGS INTO CORRIDORS. All doors opening into exit access corridors shall be protected by at least 20-minute labeled fire-door assemblies. Such doors shall be self-closing.

History: Cr. Register, December, 1981, No. 312, eff. 1-1-82.

ILHR 57.07 Steps, stairs and shafts. (1) EXTERIOR STAIRS. Exterior stairs shall be as specified in s. ILHR 51.16, except that less than 3 steps may be provided between exterior platforms and grade serving only apartments, row houses and town houses, and the platforms or treads between such risers do not exceed 5 feet 0 inches in length in the direction of travel.

(2) INTERIOR STAIRS. Interior stairs used by not more than 25 persons shall be not less than 3 feet wide.

(3) * CHANGES OF ELEVATION WITHIN INDIVIDUAL LIVING UNITS. (a) Except as provided in par. (b), changes of elevation within the living unit shall be overcome by means of steps, stairs or ramps and shall be as specified in s. ILHR 21.04.

(b) A spiral stairway as specified in s. ILHR 51.16 (7) may serve as the only exit from floor levels, within an individual living unit, if the floor level served is no larger than 400 square feet.

History: Cr. Register, December, 1981, No. 312, eff. 1-1-82; r. and recr. (3), Register, August, 1985, No. 356, eff. 1-1-86.

ILHR 57.08 Enclosure of interior stairways and shafts. (1) APPLICATION. FP
Except as provided in sub. (2), all stairways, including landings, ramps and shafts, shall be enclosed as specified in s. ILHR 51.02 (11) with fire-resistive rated construction as specified in Table 51.03-A.

(2) EXCEPTIONS. (a) The exit access stairway or shaft connecting the first and second floor in residential buildings 2 stories or less in height may be left open in the following applications providing the conditions specified in par. (b) are satisfied:

*See Appendix A for further explanatory material.

240 WISCONSIN ADMINISTRATIVE CODE

ILHR 57

Residential occupancies

1. Buildings having not more than 4 individual living units per floor each of which is served by 2 or more means of egress; or

2. Buildings having an occupancy load of 8 or less and used as rooming houses, dormitories or congregate living facilities.

(b) 1. Every exit access stairway or shaft to the basement or ground floor is cut off at the first floor or first adjacent basement or ground floor level with fire resistive construction as specified in Table 51.03-A or better; and

2. The distance to an exit, including the horizontal travel distance on the exit stair, does not exceed 50 feet in buildings not completely protected with an automatic fire sprinkler system or 75 feet in buildings completely protected as specified in s. ILHR 57.016 (1) (b).

History: Cr. Register, December, 1981, No. 312, eff. 1-1-82; am. Register, October, 1982, No. 322, eff. 11-1-82; emerg. am. (2) (b) 2., eff. 9-6-86; am. (2) (b) 2., Register, November, 1986, No. 371, eff. 12-1-86.

FP ILHR 57.09 Passageways. (1) **WHERE REQUIRED.** Where there is not direct access to outside exit doors, safe and continuous passageways, aisles or corridors leading directly to every exit shall be maintained at all times on all floors of all buildings.

(2) **MINIMUM WIDTH.** Every public passageway leading from an exit shall be at least as wide as the required width of the exit as specified in s. ILHR 51.15 (6), but in no case shall the width be less than 3 feet.

(3) **WIDTH DETERMINATION.** Widths shall be measured in the clear, at their narrowest points produced by any projection, radiator, pipe or other object.

(4) **MAINTENANCE.** The required width shall be kept clear and unobstructed at all times.

History: Cr. Register, December, 1981, No. 312, eff. 1-1-82.

FP ILHR 57.10 Illumination of exits and exit signs. (1) **ILLUMINATION.** (a) Buildings having more than 4 living units or accommodating more than 30 persons or accommodating transients shall have public passageways, stairways and exit doors illuminated from one hour after sunset to one hour before sunrise.

(b) The illumination requirements specified in par. (a) shall be provided at all intersections or passageways, at all exits and at the head, foot and landing of every stairway.

(2) **EXIT LIGHTS.** (a) Except as provided in par. (b), every required exit, from each floor shall be indicated by an approved illuminated, exit sign.

(b) 1. Exits within an individual living unit need not be provided with exit signs.

2. Exits in buildings having 4 living units or less per floor need not be provided with exit signs if the building contains not more than 8 living units and the path of exit from all floor levels including the basement to the outside is readily apparent.

(c) Exit lights shall be as specified in s. ILHR 15.15 (5).

History: Cr. Register, December, 1981, No. 312, eff. 1-1-82; am. (2), Register, December, 1983, No. 336, eff. 1-1-84.

MEANS OF EGRESS

Ch. ILHR 58

HEALTH CARE

MEANS OF EGRESS REQUIREMENTS

FP ILHR 58.04 Required means of egress. (1) GENERAL. All required means of egress shall comply with the requirements as specified in s. ILHR 51.15, except as modified in this section.

(2) EXIT DOORS. (a) *Width*. All exit doors shall be not less than 44 inches and not more than 48 inches in width, except that doors serving enclosed stairways may be a minimum of 36 inches in width.

(b) *Door swing*. A door which is used by 25 persons or less shall not be required to open in the direction of egress.

(c) *Force to open door*. The force required to fully open doors shall not exceed 37 pounds applied to the latch side.

(d) *Door platforms*. The floor on both sides of an exit door, except as specified in s. ILHR 51.16 (4) (c), shall be at the same elevation and be level for a distance at least the width of the door, or as specified in s. ILHR 52.04 (9) (b).

Register, August, 1985, No. 356

INDUSTRY, LABOR AND HUMAN RELATIONS 249
Health care, detention and correctional facilities ILHR 58

(3) EXIT ACCESS DOORS. (a) *Width*. 1. All exit access doors from hospital and nursing home sleeping rooms; patient or resident use areas; diagnostic and treatment areas, such as x-ray, surgery, or physical therapy; and all doors between these spaces and the required exits shall be at least 44 inches wide.

2. Exit access doors not subject to use by patients, shall be at least 36 inches wide.

(b) *Door swing*. A door which is used by not more than 25 persons shall not be required to open in the direction of egress.

History: Cr. Register, December, 1981, No. 312, eff. 1-1-82; am. (2) (b), Register, October, 1982, No. 322, eff. 11-1-82.

ILHR 58.05 Number and type of exits. (1) NUMBER. At least 2 exits, located remote from each other, shall be provided from each floor and fire section of the building. FP

(2) TYPE OF EXITS. (a) At least one exit from each floor or smoke compartment shall be by a door leading directly to a stairway, smokeproof tower, ramp, horizontal exit, exit passageway, or to the outside the building as specified in this subchapter.

(b) No more than one-half of the required exits shall be horizontal exits.

History: Cr. Register, December, 1981, No. 312, eff. 1-1-82.

ILHR 58.06 Stairs. (1) STAIR DETAILS. All stairs shall comply with the requirements specified in ss. ILHR 51.16 and 51.164, except as modified in this section. FP

(a) All stairways and steps shall have a rise of not more than 7 inches and not less than 4 inches and a tread not less than 11 inches, measured from tread to tread and from riser to riser. Treads and risers shall be uniform in any one flight. Winders shall not be used. Treads shall be solid.

(b) Every landing or platform shall be at least as wide as the stairway, measured at right angles to the direction of travel. The length of every landing or platform shall be at least as wide as the stairway. The length of the landing or platform need not exceed 48 inches.

(c) The aggregate width for stairways shall comply with the requirements specified in s. ILHR 58.12.

(2) ENCLOSURE. (a) All stairways shall be enclosed as specified in s. ILHR 51.18.

(b) Stairways in addition to those required by these rules, need not lead to the outside, but shall comply with the enclosure requirements.

(c) Non-required exit stairways and ramps connecting different levels within the same floor as defined in s. ILHR 51.02 (56a) are not required to be enclosed.

History: Cr. Register, December, 1981, No. 312, eff. 1-1-82; am. (1) (a) and (2) (a), Register, October, 1982, No. 322, eff. 11-1-82; r. and recr. (1) (a), Register, December, 1983, No. 336, eff. 1-1-84; cr. (2) (c), Register, August, 1985, No. 356, eff. 1-1-86.

ILHR 58.07 Handrails. Handrails shall be provided as specified in s. ILHR 51.161, except that handrails protecting the open sides of stair-

Register, August, 1985, No. 356

250 WISCONSIN ADMINISTRATIVE CODE

ILHR 58

Health care, detention and correctional facilities

ways and ramps shall have intermediate rails or an ornamental pattern designed to prevent the passage of an object with a diameter larger than 6 inches.

History: Cr. Register, December, 1981, No. 312, eff. 1-1-82; am. Register, August, 1985, No. 356, eff. 1-1-86.

ILHR 58.08 Guardrails. Guardrails shall be provided as specified in s. ILHR 51.162, except that guardrails shall have intermediate rails or an ornamental pattern designed to prevent the passage of an object with a diameter larger than 6 inches.

History: Cr. Register, December, 1981, No. 312, eff. 1-1-82.

ILHR 58.09 Smokeproof towers. Smokeproof stair towers shall comply with the requirements specified in ss. ILHR 51.17, 58.04 and 58.06.

ILHR 58.10 Horizontal exits. (1) **GENERAL.** Horizontal exits shall comply with the requirements specified in s. ILHR 51.19, except as modified in this section.

(2) **AREA.** At least 30 net square feet per occupant in a facility shall be provided within areas such as corridors, patient rooms, treatment rooms, lounge or dining areas on each side of the horizontal exit for the total number of people in the adjoining compartment.

(3) **DOORS.** (a) A single door used as a horizontal exit shall serve one direction only, be at least 44 inches wide, swing in the direction of egress and comply with the requirements specified in s. ILHR 58.21.

(b) A horizontal exit in a corridor 8 feet or more in width serving as a means of egress from both sides of the doorway shall have the opening protected by a pair of swinging doors, arranged to swing in the opposite direction from the other, with each door being at least 44 inches wide.

(c) Center mullions are prohibited.

(d) A vision panel, complying with the requirements specified in s. ILHR 51.048 and not exceeding 100 square inches, shall be provided in each horizontal exit door. Vision panels shall be set in steel frames and shall be tested as part of the entire rated door assembly.

(4) **RESTRICTIONS.** If a horizontal exit is used as a smoke barrier it shall comply with the requirements specified in s. ILHR 58.30.

History: Cr. Register, December, 1981, No. 312, eff. 1-1-82; am. (2), Register, December, 1983, No. 336, eff. 1-1-84.

ILHR 58.11 Ramps. (1) **MINIMUM WIDTH.** (a) *Interior ramps.* Interior ramps shall be a minimum of 44 inches wide, of which not more than 4 inches on each side may be occupied by a handrail.

(b) *Exterior ramps.* Exterior ramps shall be a minimum of 48 inches wide of which not more than 4 inches on each side may be occupied by a handrail.

(2) **SLOPE.** Ramps shall have a slope of not more than 1 foot of rise in 12 feet of run.

(3) **ENCLOSURE.** Ramps used as a required means of egress and that connect different floors shall comply with the enclosure requirements for stairways specified in s. ILHR 58.06 (2).

Register, August, 1985, No. 356

INDUSTRY, LABOR AND HUMAN RELATIONS 251
Health care, detention and correctional facilities ILHR 58

(4) **LANDINGS AND PLATFORMS.** (a) If a door is provided at the top or bottom or both of a ramp, a landing or platform shall be placed between the door and the ramp regardless of the direction of swing of the door.

(b) Every landing or platform shall be at least as wide as the ramp, measured at right angles to the direction of travel. The length of every landing or platform shall be at least as wide as the ramp, but need not exceed 48 inches.

History: Cr. Register, December, 1981, No. 312, eff. 1-1-82; cr. (4), Register, December, 1983, No. 336, eff. 1-1-84; am. (3), Register, August, 1985, No. 356, eff. 1-1-86.

ILHR 58.12 Capacity of means of egress. (1) **OCCUPANT LOAD.** (a) *Capacity.* The occupant load for which means of egress shall be provided for any floor shall be the maximum number of persons to occupy that floor, but not less than one person for each 120 square feet gross floor area.

(b) *Exits serving more than one floor.* Where exits serve more than one floor, only the occupant load of each floor considered individually need to be used in computing the capacity of the exits at that floor, provided the exit capacity is not decreased in the direction of exit travel.

(2) **REQUIRED EXIT WIDTH.** (a) *Units of exit width.* The required exit width shall be measured in units of exit width of 22 inches. Fractions of a unit less than 12 inches shall not be counted. Fractions of a unit 12 inches or more, added to one or more full units, shall be counted as 1/2 unit of exit width.

(b) *Clear width.* The clear width of the means of egress shall be measured at the narrowest point of the exit component under consideration, except as provided below:

1. The exit width for doorways shall be the measured width of each door leaf;
2. A handrail may project inside the measured width on each side not more than 4 inches; or
3. A stringer may project inside the measured width on each side not more than 1½ inches.

(3) **CAPACITY PER UNIT OF EXIT WIDTH.** (a) *Stairways.* The capacity of means of egress providing travel by means of stairs shall be 22 persons per exit unit, except that in buildings protected with a complete automatic sprinkler system the capacity shall not exceed 35 persons per exit unit.

(b) *Horizontal travel.* The capacity of means of egress providing horizontal travel, such as doors, ramps, or horizontal exits shall be 30 persons per exit unit, except that in buildings protected with a complete automatic sprinkler system the capacity shall not exceed 45 persons per exit unit.

History: Cr. Register, December, 1981, No. 312, eff. 1-1-82.

ILHR 58.13 Arrangement of means of egress. (1) **PATIENT SLEEPING ROOMS.** Every patient sleeping room shall have an exit access door leading directly to an exit access corridor, except as provided below:

(a) If there is an exit door opening directly to the outside from the room at ground level; or

58.13

252 WISCONSIN ADMINISTRATIVE CODE

ILHR 58

Health care, detention and correctional facilities

(b) One adjacent room, such as a sitting room or anteroom, may intervene, if all doors along the means of egress are equipped with nonlockable hardware, except as specified in s. ILHR 51.15 (3), and if the intervening room is not used to serve as an exit access for more than 8 patient sleeping beds.

(2) **CORRIDORS.** Every aisle, corridor and hallway shall provide access to at least 2 exits complying with the requirements specified in s. ILHR 58.05.

(a) *Dead end corridor.* Every exit or exit access shall be so arranged that no corridor, aisle or passageway has a pocket or dead end exceeding 30 feet.

(b) *Exit access corridors.* 1. Every aisle, corridor and hallway used for exit access shall be at least 8 feet in clear and unobstructed width of which not more than 4 inches on each side may be occupied by a handrail.

2. Where doors are placed in the exit access corridor, they shall be a pair of doors, each at least 44 inches in width. Where the exit access corridor serves as a means of egress from both sides of the doorway, the doors shall be arranged to swing in the opposite direction from the other.

(c) *Areas not intended for patient use.* Aisles, corridors and hallways in areas not intended for the housing, treatment or use of patients shall be at least 44 inches in clear and unobstructed width.

(3) **SUITE EXITING.** Any room, suite of rooms, space or area more than 1,000 square feet in area, shall have at least 2 exit access doors remote from each other.

History: Cr. Register, December, 1981, No. 312, eff. 1-1-82; am. (2) (a), Register, December, 1983, No. 336, eff. 1-1-84; renum. (2) (a) and (b) to be (2) (b) and (c), cr. (2) (a), r. (3), renum. (4) to be (3), Register, August, 1985, No. 356, eff. 1-1-86.

ILHR 58.14 Measurement of travel distance to exits. All exits of health care facilities shall be located to provide remote means of egress.

(1) **EXIT ACCESS TO AN EXIT.** Travel distance measured along passageways between any room door required as an exit access and an exit shall not exceed 100 feet, except that in buildings protected with a complete automatic sprinkler system the distance shall not exceed 150 feet.

(2) **ROOM TO AN EXIT.** Travel distance measured along passageways between any point in a room and an exit shall not exceed 150 feet, except that in buildings protected with a complete automatic sprinkler system the distance shall not exceed 200 feet.

(3) **SLEEPING ROOM TO AN EXIT ACCESS.** Travel distance measured along passageways between any point in a health care sleeping room or suite and an exit access door to that room or suite shall not exceed 50 feet.

History: Cr. Register, December, 1981, No. 312, eff. 1-1-82.

ILHR 58.15 Discharge from exits. All required ramps or stairs serving as exits shall discharge directly to the outside at grade or be arranged to travel through an exit passageway discharging to the outside at grade.
Register, August, 1985, No. 356

INDUSTRY, LABOR AND HUMAN RELATIONS 253
Health care, detention and correctional facilities ILHR 58

Unenclosed exterior ramps or stairways may not be used as required exits as specified in s. ILHR 58.04.

History: Cr. Register, December, 1981, No. 312, eff. 1-1-82; am. Register, August, 1985, No. 356, eff. 1-1-86.

ILHR 58.16 Illumination of means of egress. (1) **ILLUMINATION.** Artificial lighting shall be provided at all exits and for such period of times as required to maintain safe exiting.

(2) **ILLUMINATION LEVEL.** The floors of means of egress shall be illuminated at all points including angles and intersections of corridors and passageways, stairways, landings of stairs and exit doors to the values specified in ch. Ind 19.

History: Cr. Register, December, 1981, No. 312, eff. 1-1-82.

ILHR 58.17 Emergency lighting. Emergency lighting shall comply with the requirements specified in ch. ILHR 16.

History: Cr. Register, December, 1981, No. 312, eff. 1-1-82.

ILHR 58.18 Marking of means of egress. (1) **EXIT SIGNS.** Every required exit shall be identified with an internal illuminated, red exit sign bearing the word "EXIT" or "OUT" in plain letters not less than 6 inches high, with the principal strokes of letters not less than 3/4 inches. **FP**

(2) **DIRECTIONAL SIGNS.** An illuminated sign, not less than 6 inches high, reading "EXIT" or similar designation, with an arrow indicating the direction, shall be placed in every location where the direction of travel to reach the nearest exit is not immediately apparent.

(3) **OBSTRUCTIONS.** (a) Decorations, furnishings or equipment which impair visibility of an exit sign shall not be permitted. Displays, objects in or near the line of vision to the required exit sign or brightly illuminated signs used for purposes other than exits shall not be permitted so as to detract attention from the exit sign.

(b) Hangings or draperies shall not be placed over exit doors or be located as to conceal or obscure any exit. Mirrors shall not be placed on exit doors. Mirrors shall not be placed in or adjacent to any exit in such a manner as to confuse the direction of exit.

(4) **SPECIAL SIGNS.** Any door, passage, or stairway which is neither an exit nor a way of exit access, and which is located or arranged that it may be mistaken for an exit, shall be identified by a sign indicating it is not an exit.

History: Cr. Register, December, 1981, No. 312, eff. 1-1-82.

ILHR 58.19 Headroom. Every means of egress shall be provided with a ceiling clearance of not less than 7 feet 6 inches.

History: Cr. Register, December, 1981, No. 312, eff. 1-1-82.

ILHR 58.20 Key locking hardware. Key locking hardware on exit doors and exit access doors is prohibited except in areas accommodating residents who must be detained for their protection and the protection of the general public and the building complies with the requirements of ch. **FP**

Register, August, 1985, No. 356

58.20

254

WISCONSIN ADMINISTRATIVE CODE

ILHR 58

Health care, detention and correctional facilities

ILHR 58, subchs. I and II. Where the requirements of the 2 subchapters differ, the additional or more stringent requirement shall govern.

History: Cr. Register, December, 1981, No. 312, eff. 1-1-82; r. and recr. Register, December, 1983, No. 336, eff. 1-1-84.

MEANS OF EGRESS

Ch. ILHR 58

PLACES OF DETENTION

58.48

266

WISCONSIN ADMINISTRATIVE CODE

ILHR 58

Health care, detention and correctional facilities

MEANS OF EGRESS REQUIREMENTS

FP ILHR 58.48 Required means of egress. (1) GENERAL REQUIREMENTS. All required means of egress doors shall comply with s. ILHR 51.15, except as modified in this section and s. ILHR 58.59.

(2) **DOORS IN MEANS OF EGRESS.** (a) Doors in a means of egress may be of the horizontal sliding type, providing the force to slide the door to its fully open position does not exceed 37 pounds.

(b) A door which serves an area with a capacity not more than 25 persons is not required to open in the direction of egress.

(3) **EXIT DISCHARGE.** Exit discharge may terminate at one of the following:

(a) Directly at the exterior of the building;

(b) At a horizontal exit; or

(c) Into a fenced or walled court, provided that not more than 2 walls of the court are the walls of the building from which exit is being made. Enclosed yards or courts shall be sized to accommodate all occupants, a minimum of 30 feet from the building with a net area of 15 square feet per person. Access from the fenced or walled court to the public thoroughfare may be fenced and locked.

(4) **EXIT ACCESS.** A dayroom may serve as a portion of the exit access from a sleeping room.

History: Cr. Register, December, 1981, No. 312, eff. 1-1-82.

FP ILHR 58.49 Exit doors, number and type of exits. (1) NUMBER. At least 2 exits shall be accessible from each floor of the building and shall be located such that in case any exit is blocked, some other exit will still be accessible.

(2) **EXIT DOORS.** All exit doors shall be at least 36 inches in width.

(3) **EXIT ACCESS DOORS.** All exit access doors shall be at least 36 inches in width, except for the following modifications:

(a) Doors to sleeping rooms shall be at least 28 inches in width;

(b) Doors to sleeping rooms designated for use by the physically disabled shall be at least 32 inches in width; or

(c) Doors to dayrooms shall be at least 32 inches in width.

(4) **TYPE OF EXITS.** (a) Required exits shall be by a door leading directly to a stairway, smokeproof tower, ramp, horizontal exit, exit passageway or outside the building as specified in this subchapter. No more than one-half of the required exits may be horizontal exits.

(b) Where a detention or correctional facility, other than a hospital or nursing home, is located on the upper floors of a building having a different occupancy, at least one of the exits from the detention or correctional facility shall be a separate smokeproof tower as specified in s. ILHR 51.17. The smokeproof tower shall serve only the detention or correctional facility. Register, August, 1985, No. 356

INDUSTRY, LABOR AND HUMAN RELATIONS 267
Health care, detention and correctional facilities ILHR 58

tional facility and there shall be no doors opening into the smokeproof tower from any other occupancy of the building.

History: Cr. Register, December, 1981, No. 312, eff. 1-1-82.

ILHR 58.50 Stairways. (1) GENERAL. (a) All required exit stairways shall comply with the requirements specified in s. ILHR 51.16 and shall be enclosed as specified in s. ILHR 51.18.

FP

(b) 1. Except as provided in subd. 2., stairways in addition to those required by this chapter need not lead to the outside but shall be enclosed as required in par. (a).

2. Nonrequired stairways serving open mezzanines need not be enclosed.

(2) STAIRWAY TERMINATION. Stairways provided in addition to those required by this subchapter shall be enclosed as specified in s. ILHR 51.18 but need not lead to the outside. A sign or label shall be posted on the doors of the stair enclosures and shall bear the following: "Not an Exit".

History: Cr. Register, December, 1981, No. 312, eff. 1-1-82; am. Register, December, 1983, No. 336, eff. 1-1-84; am. (1) (a) and cr. (1) (b), Register, August, 1985, No. 356, eff. 1-1-86.

ILHR 58.51 Smokeproof towers. Smokeproof stair towers shall comply with the requirements specified in ss. ILHR 51.17 and 58.48.

FP

History: Cr. Register, December, 1981, No. 312, eff. 1-1-82.

ILHR 58.52 Horizontal exits. (1) GENERAL. Horizontal exits shall comply with the requirements in s. ILHR 51.19, except as modified in this section.

(2) AREA. At least 6 net square feet of accessible space per occupant shall be provided on each side of the horizontal exit for the total number of people in the adjoining compartment.

(3) DOORS. (a) A single door used as a horizontal exit shall serve one direction only, be at least 36 inches wide and swing in the direction of egress.

(b) Horizontal exit doors may be locked as specified in s. ILHR 58.59.

(4) RESTRICTIONS. If a horizontal exit is used as a smoke barrier, it shall comply with s. ILHR 58.67.

History: Cr. Register, December, 1981, No. 312, eff. 1-1-82.

ILHR 58.53 Ramps. (1) MINIMUM WIDTH. (a) Interior ramps. Interior ramps shall be a minimum of 44 inches wide, of which not more than 4 inches on each side may be occupied by a handrail.

(b) Exterior ramps. Exterior ramps shall be a minimum of 48 inches wide, of which not more than 4 inches on each side may be occupied by a handrail.

(2) SLOPE. Ramps shall have a slope of not more than one foot of rise in 8 feet of run, except ramps providing access for the disabled shall comply with s. ILHR 52.04 (7).

(3) ENCLOSURE. Ramps used as a required means of egress shall comply with the enclosure requirements for stairways in s. ILHR 51.18.

58.53

268

WISCONSIN ADMINISTRATIVE CODE

ILHR 58

Health care, detention and correctional facilities

(4) **LANDINGS AND PLATFORMS.** (a) If a door is provided at the top or bottom or both of a ramp, a landing or platform shall be placed between the door and the ramp regardless of the direction of swing of the door.

(b) Every landing or platform shall be at least as wide as the ramp, measured at right angles to the direction of travel. The length of every landing or platform shall be at least as wide as the ramp, but need not exceed 48 inches.

History: Cr. Register, December, 1981, No. 312, eff. 1-1-82; cr. (4), Register, December, 1983, No. 336, eff. 1-1-84.

ILHR 58.54 Required exit width. (1) **OCCUPANT LOAD.** The occupant load for which means of egress shall be provided shall be the maximum number of persons occupying that floor, but not less than one person for each 120 sq. ft. gross floor area.

(2) **REQUIRED EXIT WIDTH.** The required exit width shall comply with s. ILHR 51.15 (6).

History: Cr. Register, December, 1981, No. 312, eff. 1-1-82.

ILHR 58.55 Arrangement of means of egress. (1) **SLEEPING ROOM.** Every sleeping room shall have a door leading directly to an exit access, except where an exit door opens directly to the outside from the room at the ground level.

(2) **CORRIDOR ACCESS.** (a) Every aisle, corridor and hallway shall provide access to at least 2 exits complying with s. ILHR 58.48.

(b) Every aisle, corridor and hallway used for exit access shall be at least 44 inches in clear and unobstructed width.

(3) **EXIT PASSAGEWAYS.** Every exit passageway shall be at least 44 inches in width.

(4) **AREA EXITING.** Any room, suite of rooms, space or area accommodating 25 persons or more, shall have at least 2 exit access doors distributed to provide the best possible means of egress from the room.

(5) **SECURITY VESTIBULE EXITING.** A security vestibule may be permitted in a means of egress where there are provisions for continuous and unobstructed passage through the security vestibule during an emergency exit condition.

(6) **DEAD END CORRIDOR.** Every exit or exit access shall be so arranged that no corridor, aisle or passageway has a pocket or dead end exceeding 30 feet.

History: Cr. Register, December, 1981, No. 312, eff. 1-1-82; cr. (6), Register, August, 1985, No. 356, eff. 1-1-86.

ILHR 58.56 Measurement of travel distance to exits. All exits in detention and correctional facilities shall be located to provide means of egress remote from one another.

(1) **EXIT ACCESS TO AN EXIT.** Travel distance shall be measured along passageways. The distance between any room door required as an exit access and an exit shall not exceed 100 feet, except that in buildings protected with a complete automatic sprinkler system the distance shall not exceed 150 feet.

Register, August, 1985, No. 356

INDUSTRY, LABOR AND HUMAN RELATIONS 269
Health care, detention and correctional facilities ILHR 58

(2) ROOM TO AN EXIT. Travel distance shall be measured along passageways. The distance between any point in a room and an exit shall not exceed 150 feet, except that in buildings protected with a complete automatic sprinkler system the distance shall not exceed 200 feet.

(3) SLEEPING ROOM TO AN EXIT ACCESS. Travel distance shall be measured along passageways. The distance between any point in a sleeping room or suite and an exit access door to that room or suite shall not exceed 50 feet.

History: Cr. Register, December, 1981, No. 312, eff. 1-1-82.

ILHR 58.57 Illumination of means of egress. (1) ILLUMINATION. Artificial lighting shall be provided at all exits and for such period of times as required to maintain safe exiting.

(2) ILLUMINATION LEVEL. The floors of means of egress shall be illuminated at all points including angles and intersections of corridors and passageways, stairs, landings of stairs and exit doors to values specified in ch. Ind 19.

History: Cr. Register, December, 1981, No. 312, eff. 1-1-82.

ILHR 58.575 Emergency lighting. Emergency lighting complying with the requirements specified in ch. ILHR 16 shall be required when 20 or more resident beds are provided. FP

History: Cr. Register, December, 1983, No. 336, eff. 1-1-84.

ILHR 58.58 Marking of means of egress. (1) EXIT SIGNS. Every required exit shall be identified with an internal illuminated, red exit sign bearing the word "EXIT" or "OUT" in plain letters not less than 6 inches high, with the principal strokes of the letter not less than 3/4 inches. FP

(2) DIRECTIONAL SIGNS. An illuminated sign, not less than 6 inches high, reading "EXIT" or similar designation, with an arrow indicating the direction, shall be placed in every location where the direction of travel to reach the nearest exit is not immediately apparent.

(3) OBSTRUCTIONS. (a) Decorations, furnishings or equipment which impair visibility of an exit sign shall not be permitted. Displays, objects in or near the line of vision to the required exit sign, or brightly illuminated signs used for purposes other than exits shall not be permitted so as to detract attention from the exit sign.

(b) Hangings or draperies shall not be placed over exit doors or be located as to conceal or obscure any exit. Mirrors shall not be placed on exit doors. Mirrors shall not be placed in or adjacent to any exit in such a manner as to confuse the direction of exit.

(4) SPECIAL SIGNS. Any door, passage, or stairway which is neither an exit nor a way of exit access, and which is located or arranged that it may be mistaken for an exit, shall be identified by a sign indicating it is not an exit.

History: Cr. Register, December, 1981, No. 312, eff. 1-1-82.

ILHR 58.59 Door locks. All doors in detention and correctional facilities having locking devices shall comply with the following requirements: FP

Register, August, 1985, No. 356

58.59

270 WISCONSIN ADMINISTRATIVE CODE
ILHR 58 Health care, detention and correctional facilities

(1) LOCKING OF MEANS OF EGRESS DOORS. All doors in detention and correctional facilities may be locked in accordance with this section, providing that staff is on duty 24 hours a day.

(a) *Locks at sleeping rooms.* 1. Single sleeping room. A single sleeping room may be key locked.

2. Two or more sleeping rooms. Where 2 or more sleeping rooms within a smoke compartment are locked, a remote locking and unlocking device shall be provided. The remote locking and unlocking device shall be located outside of the sleeping room areas.

(b) *Locks at exterior doors, stairways and horizontal exits.* Doors from the secured areas to the exterior of the building, into stairway enclosures or at horizontal exits may be locked with a key lock. The keys to unlock such doors shall be maintained and available at the facility at all times and the locks shall be operable from the outside.

(2) REMOTE RELEASE. All remote release operated doors shall be provided with a back-up means of operation as follows:

(a) Power-operated sliding doors or power operated locks shall be so constructed that in the event of power failure a manual mechanical means to release and open the doors is provided at each door and either emergency power in accordance with ch. ILHR 16 is provided for the power operation or a remote manual mechanical release is provided.

(b) Mechanically operated sliding doors or mechanically operated locks shall be provided with a manual mechanical means to release and open the door at the door.

(3) REMOTE UNLOCKING. Doors remotely unlocked under emergency conditions shall not automatically relock when closed unless specific action is taken at the remote location to enable doors to relock.

(4) STANDBY EMERGENCY POWER. Standby emergency power shall be provided for all electrically power-operated doors and power-operated locks. Power shall be arranged to automatically operate upon failure of normal power within 10 seconds and to maintain the necessary power source for at least 1½ hours.

History: Cr. Register, December, 1981, No. 312, eff. 1-1-82; am. (1) (b), Register, December, 1983, No. 336, eff. 1-1-84; r. and recr. (2), Register, August, 1985, No. 356, eff. 1-1-86.

MEANS OF EGRESS

Ch. ILHR 59

HAZARDOUS OCCUPANCIES

282

WISCONSIN ADMINISTRATIVE CODE

ILHR 59

Hazardous occupancies

FP ILHR 59.13 Types of exits. (1) **GENERAL.** (a) Only the following types of exits shall be used to comply with the provisions of s. ILHR 59.14:

1. Standard exit as specified in s. ILHR 51.15, except as provided in sub. (2);
2. Stairways as specified in s. ILHR 51.16, except as provided in sub. (2);
3. Smokeproof stair tower as specified in s. ILHR 51.17;
4. Interior enclosed stairway as specified in s. ILHR 51.18;
5. Horizontal exit as specified in s. ILHR 51.19;
6. Fire escapes as specified in s. ILHR 51.20; and
7. Nonparking access ramps with a maximum slope of 1:8.

(b) At least half of the exits required under s. ILHR 59.14 shall be standard exits, stairways, smokeproof stair towers or interior enclosed stairways to grade.

(2) **EXCEPTIONS.** (a) A spiral stairway shall not serve as a required exit, but may be used as an employe convenience stairway if located in nonpublic areas.

(b) The width of required exit stairways serving unoccupied areas, such as storage areas, equipment mezzanines and similar areas not exceeding 750 sq. ft. may be reduced to 3 feet 0 inches.

(c) Doors in standard exits serving rooms, spaces or areas with an occupancy load of 25 persons or less are not required to swing in the direction of egress.

(d) A door not complying with s. ILHR 51.15 (2), may be used as a standard exit serving storage garages or storage areas not exceeding 3,000 square feet in area.

Note: Where accessibility and interior circulation for persons with functional limitations must be provided, the requirements of s. ILHR 52.04 (9) govern.

History: Cr. Register, December, 1981, No. 312, eff. 1-1-82; am. (2) (d), Register, August, 1985, No. 356, eff. 1-1-86.

FP ILHR 59.14 Number and location of exits. (1) **GENERAL.** (a) Except as provided in par. (b), every floor level and every room, space or area of a storage garage and a repair garage shall be provided with at least 2 exits.

(b) One exit is permitted from the following:

1. Any room, space or area used for storage garage purposes with an occupancy load of 10 persons or less and which does not exceed 3,000 sq. ft. in net floor area;

2. Any room, space or area used for repair garage purposes and does not exceed 750 sq. ft. in net floor area;

3. Any room, space or area used as other than a storage or repair garage with an capacity of 25 persons or less; and

4. A mezzanine floor level, provided the mezzanine is:
 - a. Three thousand square feet or less in net floor area;

INDUSTRY, LABOR AND HUMAN RELATIONS 282-1
Hazardous occupancies **ILHR 59**

- b. Used only for storage purposes;
- c. Open on at least one side to the floor below; and
- d. Not more than 12 feet above the floor below.

(2) **EXIT DISTANCE.** Exits shall be provided and distributed as follows:

(a) *Storage garages.* 1. No area of a storage garage shall be more than 100 feet from an exit, unless the entire storage garage is protected by an automatic sprinkler system.

2. No area of a storage garage entirely protected by an automatic fire sprinkler system shall be more than 200 feet from an exit.

(b) *Repair garages.* 1. No area of a repair garage shall be more than 75 feet from an exit, unless the entire repair garage is protected by an automatic fire sprinkler system.

2. No area of a repair garage entirely protected by an automatic fire sprinkler system shall be more than 150 feet from an exit.

(c) * *Measurement of exit distance.* The exit distances required by this section shall be measured along public passageways and aisles to:

1. Standard exits leading to grade as specified in s. ILHR 51.15;

2. Doors opening into smokeproof stair towers as specified in s. ILHR 51.17, interior enclosed stairways as specified in s. ILHR 51.18, or fire escapes as specified in s. ILHR 51.20; or

3. Horizontal exits as specified in s. ILHR 51.19.

(3) **LOCATION OF EXITS.** Except as provided in sub. (1) (b), exits in all storage garages and repair garages shall be located and distributed so that in the event an exit is blocked, another exit is available from every area of the storage garage or repair garage.

(4) **EXIT LIGHTS.** All required exits shall be identified by an approved exit light. Directional exit lights shall be provided to direct occupants to the exits. Exit lights and directional exit lights shall be as specified in s. ILHR 51.15 (5).

(5) **EXIT MAINTENANCE.** Exits shall be maintained in accordance with s. ILHR 52.21.

History: Cr. Register, December, 1981, No. 312, eff. 1-1-82; cr. (4), Register, December, 1983, No. 336, eff. 1-1-84; emerg. am. (2) (a) 2. and (b), eff. 9-6-86; am. (2) (a) 2. and (b), Register, November, 1986, No. 371, eff. 12-1-86.

ILHR 59.15 Required exit width. (1) **GENERAL.** Every floor level of a storage garage and repair garage shall be provided with at least the required aggregate width of exits as specified in ss. ILHR 51.15 (6) and 51.16 (3).

(2) **HORIZONTAL EXITS.** Horizontal exits may provide up to one-half of the required aggregate width of exits for a floor level.

History: Cr. Register, December, 1981, No. 312, eff. 1-1-82.

*See Appendix A for further explanatory material.

59.16

282-2 WISCONSIN ADMINISTRATIVE CODE
ILHR 59 Hazardous occupancies

ILHR 59.16 Capacity of structures. In calculating the required aggregate width of exits under s. ILHR 59.15 and the required number of sanitary facilities under s. ILHR 59.20, the capacities of structures and floor levels shall be computed on the following basis:

- (1) Storage garages and repair garages - 300 sq. ft. per person; and
- (2) Other areas as dictated by the appropriate sections of chs. ILHR 54 to 62.

Note: See ss. ILHR 54.05, 55.06, 56.07 for additional requirements.

History: Cr. Register, December, 1981, No. 312, eff. 1-1-82.

ILHR 59.17 Enclosure of stairways and shafts. (1) **GENERAL.** (a) Except **FP** as provided in par. (b), all stairways and shafts within a storage garage and a repair garage shall be fully enclosed with smoke partitions. Smoke partitions shall be constructed of solid and rigid materials. Openings in such enclosures shall be protected with doors equipped with automatic closing devices.

(b) Stairways to open storage mezzaniness 3,000 square feet or less in area are not required to be enclosed.

(2) **THREE OR MORE FLOOR LEVELS.** Stairways and shafts serving 3 or more floor levels shall be enclosed pursuant to s. ILHR 51.18 with fire-resistant construction as specified in Table 51.03-A.

History: Cr. Register, December, 1981, No. 312, eff. 1-1-82; reprinted to correct error in (2), Register, February, 1982, No. 314; am. (2), Register, October, 1982, No. 322, eff. 11-1-82.

MEANS OF EGRESS

Ch. ILHR 60

GENERAL

FP ILHR 60.12 Doors. (1) All exit doors, and all doors along the path of travel to an exit, shall meet the requirements of s. ILHR 51.15 with the following exceptions:

(a) The width of all required exit doors may be reduced to 2 feet 8 inches in existing buildings not accommodating more than 8 children;

(b) All such doors used by not more than 25 persons need not swing outward;

(c) All such doors in centers serving 20 or less children need not be provided with illuminated exit signs; and

(d) Sliding glazed patio-type doors may serve as the second exit. A means to prevent accumulation of snow and ice in the door track or freezing of the door shall be provided.

(2) Every closet door latch shall be such that children can open the door from inside the closet.

(3) Every toilet room door lock shall be designed to permit opening of the locked door from the outside in an emergency, and the opening device shall be readily accessible to the staff.

History: Cr. Register, October, 1974, No. 226, eff. 11-1-74; cr. (1)(d), Register, December, 1977, No. 264, eff. 1-1-78; r. (1)(a), renum. (1)(b) to (d) to be (1)(a) to (c), Register, January, 1980, No. 289, eff. 2-1-80; am. (1) (c), Register, May, 1980, No. 293, eff. 6-1-80; cr. (1) (d), Register, December, 1981, No. 312, eff. 1-1-82.

MEANS OF EGRESS

Ch. ILHR 60

4 to 8

ILHR 60.21 Exiting. (1) Children under the age of 24 months shall be restricted to the first floor, as determined in s. ILHR 51.02 (14), or to ground floors as defined in s. ILHR 51.01 (67). **FP**

(2) Each floor occupied by children shall have not less than 2 exits.

(3) The exits shall be located to provide the best possible means of egress.

(4) Where the floor above exit discharge grade is used by children for sleeping purposes, one exit shall lead directly from the floor to the exterior.

(5) Travel distance from any point to an outside exit door or stair enclosure leading to the outside shall not exceed 75 feet. Travel distance may be increased to 125 feet when the building is provided with a sprinkler system in accordance with the requirements of s. ILHR 51.23.

History: Cr. Register, October, 1974, No. 226, eff. 11-1-74; am. (1), Register, December, 1977, No. 264, eff. 1-1-78; am. (1), Register, December, 1983, No. 336, eff. 1-1-84.

ILHR 60.22 Passageways. The minimum unobstructed passageway width shall not be less than 3 feet. **FP**

History: Cr. Register, October, 1974, No. 226, eff. 11-1-74.

ILHR 60.23 Stair and shaft enclosure. (1) A self-closing door shall be provided at the stair between the basement or ground floor and the first floor. **FP**

(2) A self-closing door or smoke detector shall be provided at the stair between the first floor and the second floor when the second floor is used by the children for sleeping purposes. (This requirement does not apply to buildings which are provided with a fire alarm system as described in s. ILHR 51.24.)

(3) Unenclosed stairways, connecting the floor of exit discharge with one adjacent floor level, may be used as required exits provided the stairways are enclosed at all levels with solid partitions. Openings in the partitions shall be protected with self-closing doors.

History: Cr. Register, October, 1974, No. 226, eff. 11-1-74; am. (3), Register, October, 1982, No. 322, eff. 11-1-82; am. (3), Register, December, 1983, No. 336, eff. 1-1-84; r. and recr. (3), Register, August, 1985, No. 356, eff. 9-1-85.

MEANS OF EGRESS

Ch. ILHR 60

9 or MORE

ILHR 60.31 Exiting. (1) Each floor shall have not less than 2 exits. All required exits shall lead directly, or through an enclosed stairway, to the outside. **FP**

(2) The exits shall be located to provide the best possible means of egress.

(3) Travel distance measured along safe passageways between:

(a) Any point in a sleeping room or suite and an exit access door of that room or suite shall not exceed 50 feet;

(b) Any room door intended as an exit access and an exit shall not exceed 50 feet; and

(c) Any point in a room or suite and an exit shall not exceed 100 feet.

(4) The travel distances in sub. (3) shall be reduced by 50% for children under the age of 24 months.

(5) The travel distances in sub. (3) may be increased by 50 feet in buildings completely protected with an automatic fire sprinkler system. No increase in travel distance is permitted for children under the age of 24 months.

(6) Children under the age of 24 months shall be restricted to the first floor, as determined in s. ILHR 51.02 (14), or to ground floors as defined in s. ILHR 51.01 (67).

History: Cr. Register, October, 1974, No. 226, eff. 11-1-74; am. (4), (5) and (6) Register, December, 1977, No. 264, eff. 1-1-78; am. (6), Register, December, 1983, No. 336, eff. 1-1-84; am. (4) and (5), Register, August, 1985, No. 356, eff. 9-1-85.

ILHR 60.32 Required exit width. (1) The total required exit width from a building level shall be in accordance with the requirements of ss. ILHR 51.15 (6) and 51.16 (3). **FP**

(2) If horizontal exits (s. ILHR 51.19) are provided for any floor, the number of persons accommodated on such floor may be increased at the rate of 100 persons for each 40 inches of width of such exits, provided such increase shall not exceed 100% of the number of persons accommodated by the stairways.

History: Cr. Register, October, 1974, No. 226, eff. 11-1-74; r. and recr. Register, December, 1974, No. 228, eff. 1-1-75.

ILHR 60.33 Passageways. (1) The minimum unobstructed width of corridors and passageways shall be determined in the same manner as specified for stairways and exits in s. ILHR 60.32. The minimum width shall be not less than 3 feet 8 inches. **FP**

Register, August, 1985, No. 356

60.33

296 WISCONSIN ADMINISTRATIVE CODE
ILHR 60 Child Day Care Facilities

(2) The minimum passageway width shall not be less than 3 feet in existing buildings proposed to be used as day care centers, provided the capacity of the day care center does not exceed 40 persons.

History: Cr. Register, October, 1974, No. 226, eff. 11-1-74.

FP ILHR 60.34 Stair and shaft enclosure. (1) GENERAL. Except as provided in sub. (2), all stairs and vertical shafts serving 2 or more floor levels shall comply with the requirements of s. ILHR 51.02 (11) and Table 51.03-A. All required stair enclosures shall lead to the outside without interruption.

(2) EXCEPTIONS. (a) Exit stairways serving day care centers located in one story places of worship need not be enclosed.

(b) Exit stairways serving day care centers located in one and two story schools constructed prior to January 1, 1982 need not be enclosed.

(c) Unenclosed stairways, connecting the floor of exit discharge with one adjacent floor level, may be used as required exits for day care centers accommodating 9 to 39 children, provided the stairways are enclosed at all other levels with fire-resistive rated construction equal to or better than the hourly rating specified in Table 51.03-A.

History: Cr. Register, October, 1974, No. 226, eff. 11-1-74; am. (1), Register, October, 1982, No. 322, eff. 11-1-82; r. and recr. Register, August, 1985, No. 356, eff. 9-1-85.

FP ILHR 60.35* Fire extinguishers. Portable fire extinguishers suitable for Class B fires shall be installed in kitchens and cooking areas, and extinguishers suitable for Class A fires shall be installed throughout the remainder of the center.

TABLE 60.35

Basic Minimum Extinguisher Rating for Area Specified	Maximum Travel Distance to Extinguishers (feet)	Area to be Protected per Extinguisher (square feet)
1A	75	3,000
2A	75	6,000
3A	75	9,000
4A	75	11,250
6A	75	11,250

History: Cr. Register, October, 1974, No. 226, eff. 11-1-74.

MEANS OF EGRESS

Ch. ILHR 61

COMMUNITY-BASED RESIDENTIAL FACILITIES (CBRF)
AND SHELTERED FACILITIES FOR BATTERED WOMEN

FP ILHR 61.12 Exiting and doors. (1) NUMBER, TYPE AND ACCESS TO EXITS.

(a) All CBRF, and each floor level having habitable rooms, shall have at least 2 means of exit which provide unobstructed travel to the outside at street or grade level.

1. *Exception.* A single exit will be permitted from basements or attics utilized for recreational, nonsleeping purposes only.

2. A wooden balcony or a flat roof, within 10 feet of grade, or an exterior wood stair may serve as one of the required exits from the second floor of a 2-story CBRF, except Class B and C CBRF with nonambulatory residents on the second floor.

(b) Exits shall be standard exits to grade (doors), stairways as specified in sub. (3), or fire escapes. (See exception under sub. (1) (a) 1.)

(c) No exit passageway shall be through a private room or bath/toilet room.

(d) Exit passageways and stairways to the outside exits shall be at least 3 feet wide, except existing secondary exit passageways, stairways and doors may be reduced to 2 feet 4 inches in width.

(e) The required width shall be maintained clear and unobstructed at all times.

(2) **DOORS.** (a) Outside exit doors and doors in exit access corridors shall be at least 2 feet 8 inches in width, except as provided in sub. (1) (d) for existing secondary exit doors.

(b) All doors shall have such fastenings or hardware that they can be opened from the inside with one hand without the use of a key.

(c) Closet doors shall be openable from the inside.

(d) All interior doors equipped with locks shall be designed to permit opening of the locked doors from either side in case of emergency.

(3) **STAIRS: GENERAL.** (a) *Treads and risers.* All required interior and exterior exit stairways shall have a minimum tread width (exclusive of nosing or projection) of 9 inches and a maximum riser height of 8 inches.

1. *Exception.* Stairs serving basements and attics without habitable rooms may have a minimum tread width (exclusive of nosing or projection) of 8 inches and a maximum riser height of 9 inches.

(b) *Handrails.* One or more handrails, at least 29 inches above the nose of the tread, shall be provided on all stairways. Handrails shall be provided on the open sides of stairways and platforms.

(c) *Winder stairs.* 1. Winders in stairways shall be provided with handrails on both sides, at least 29 inches above the nose of the tread.

2. Winders in stairways used as required exits shall have treads of at least 7 inches in width at a point one foot from the narrow end of the tread.

61.14

DEPT. OF INDUSTRY, LABOR & HUMAN RELATIONS 305
Community-Based Residential Facilities ILHR 61

(d) *Spiral stairs.* Spiral stairs shall be prohibited for use as required exit stairs.

(4) STAIRS: ENCLOSURE. (a) Three-story CBRF shall have at least one stairway exit, enclosed with at least one-hour rated construction, leading to a first-story outside exit.

(b) CBRF, 4 or more stories in height, shall have all stairways enclosed with at least one-hour rated construction. All required exit stairways shall have such enclosures leading to a first-story outside exit.

Note: Buildings of Type 1 and 2 construction require 2-hour rated stair enclosures in accordance with s. ILHR 51.03 (1) and (2).

(5) ILLUMINATION. All exit passageways and stairways shall be capable of being illuminated at all times.

History: Cr. Register, May, 1978, No. 269, eff. 7-1-78.

MEANS OF EGRESS

Ch. ILHR 62

OPEN PARKING STRUCTURES

FP ILHR 62.26 Number, location and type of pedestrian exits. (1) **NUMBER OF EXITS.** Every open parking structure and every floor level thereof shall have at least 2 exits.

(2) **DISTANCE TO EXITS.** Additional exits shall be provided so that no part of the open parking structure will be more than 200 feet distant to the exit discharge grade or to a stair enclosure if the walls separating the stair from the open parking structure are of at least noncombustible one-hour (NC-1) rating or better and the enclosure is continuous to an outside exit.

Note: In all cases, required exit stairs are required to be enclosed (see s. ILHR 62.27). If the designer elects to increase the exit distance by measuring to the stair enclosure, the enclosure must have at least a noncombustible one-hour (NC-1) rating.

(3) **LOCATION OF EXITS.** Exits in all open parking structures shall be placed as far apart as practicable and so located that if any exit is blocked, some other exit will still be available from every part of the structure.

(4) **TYPE OF EXITS.** At least one-half of the exits required by this section shall be standard exits to grade, stairways or horizontal exits as specified in ss. ILHR 51.15, 51.16 and 51.19, respectively. The other exits may be non-parking access ramps with a maximum slope of 1:8.

History: Cr. Register, December, 1977, No. 264, eff. 1-1-78; am. (4), Register, December, 1978, No. 276, eff. 1-1-79; am. (4), Register, January, 1980, No. 289, eff. 2-1-80.

ILHR 62.27 Stairway enclosures. Stair enclosures of NC-0 hour rating, or better, shall be provided for all required exit stairways, unless otherwise required to be rated.

Note: It is the intent of s. ILHR 62.27 to require all required exit stairs to be enclosed. If the designer elects to measure the exit distance to the stair enclosure, the enclosure must be then rated. (See s. ILHR 62.26 (2).)

History: Cr. Register, December, 1977, No. 264, eff. 1-1-78.

MEANS OF EGRESS

Ch. ILHR 62

TENTS

ILHR 62.47 Exits. (1) NUMBER OF EXITS. (a) Every tent occupied by the public shall have at least 2 standard exits located at or near opposite ends of the structure. **FP**

(b) In tents used for assembly purposes, exits shall be provided on 3 sides if the capacity exceeds 600 persons and on 4 sides where the capacity exceeds 1,000 persons.

(2) **EXIT DISTANCE.** Exits shall be uniformly distributed but in no case shall the line of travel to an exit be greater than 150 feet.

(3) **EXIT WIDTH.** The total width of exits from a tent used for assembly purposes shall be not less than 44 inches per 100 persons. Exit openings shall comply in all respects with with the requirements of ss. ILHR 51.15 and 55.10 of this code.

History: Cr. Register, January, 1980, No. 289, eff. 2-1-80.

MEANS OF EGRESS

Ch. ILHR 62

ASSEMBLY SEATING

ILHR 62.75 Means of egress. (1) TYPE OF EXITS. (a) Except as provided in par. (b), all required exits from any part of a seating facility shall be doorways, stairways or ramps conforming to the requirements specified in ss. ILHR 55.08 through 55.10. FP

(b) Doorways, stairways and ramps are not required for assembly seating facilities when aisles are not required.

(2) **NUMBER OF EXITS. (a) *Outdoor seating.*** Every outdoor seating facility, and every balcony or tier considered separately, shall be provided with at least 2 exits located as remote from each other as practicable and leading directly to the outside at grade. If the capacity of any such facility, balcony or tier exceeds 1,000 persons, there shall be at least 3 exits

Register, August, 1985, No. 356

326

WISCONSIN ADMINISTRATIVE CODE

ILHR 62

Specialty Occupancies

and where the capacity exceeds 4,000 persons, there shall be at least 4 exits.

(b) *Indoor seating.* The number of exits for every indoor seating facility shall comply with the requirements as specified in s. ILHR 55.07.

(3) **DISTANCE TO EXITS.** Exits shall be distributed uniformly to prevent congestion and shall be so located that the line of travel to an exit or to a street, alley or open court is not greater than 150 feet.

(4) **AGGREGATE WIDTH OF EXITS.** (a) *Outdoor seating.* The total clear width of exits from any outdoor seating facility shall be not less than 22 inches for each 500 persons, or fraction thereof.

(b) *Indoor seating.* The total clear width of exits off of any indoor seating facility shall be not less than 22 inches per 100 persons, or fraction thereof.

(5) **EXIT LIGHTS AND SIGNS.** Exit lights and signs shall comply with the requirements as specified in s. ILHR 55.11.

(6) **AISLES REQUIRED.** (a) Except as provided in par. (b), aisles shall be required in all seating facilities.

(b) Aisles may be omitted provided all of the following conditions exist:

1. Seats are without backrests;
2. The rise between rows does not exceed 12 inches;
3. The number of rows does not exceed 20 for outdoor seating facilities or 16 for indoor seating facilities;
4. The row spacing does not exceed 28 inches; and
5. The first seatboard is not more than 20 inches above the ground or floor.

(7) **AISLE WIDTH.** Aisles having seats on both sides shall be not less than 42 inches in width and aisles having seats on one side only shall be not less than 36 inches wide.

(8) **AISLE LOCATION.** (a) *Outdoor seating.* For seating not within a building, the number of seats between any seat and an aisle shall not be greater than 20 when the seats are without backrests and 11 when the seats have backrests.

(b) *Indoor seating.* Except as provided in par. (c), the number of seats between any seat and an aisle for seating within a building, shall not be greater than 9 when the seats are without backrests and 6 when the seats have backrests.

(c) *Continental seating.* The number of seats between any seat and an aisle may be increased to 49 where:

1. A minimum unobstructed passage of 22 inches is provided between rows of unoccupied seats; and
2. The unobstructed passage between rows leads to a side aisle on each end of the rows where exit doors are located at no more than 20 foot intervals leading to an exit corridor or exit court.

DEPT. OF INDUSTRY, LABOR & HUMAN RELATIONS 327
Specialty Occupancies ILHR 62

(9) CROSS AISLES. Where provided, aisles parallel to the seat rows shall be not less than 48 inches in width.

(10) UNOBSTRUCTED MEANS OF EGRESS. No aisle, stair, door or other way of ingress or egress shall be obstructed in any manner while the seating facility is occupied by the public.

History: Cr. Register, December, 1981, No. 312, eff. 1-1-82.

ILHR 62.76 Seating. (1) SEATING ARRANGEMENTS. A minimum 12-inch spacing shall be provided between the back of each seat and the front of the seat immediately behind it. The seating arrangement shall comply with the spacing requirements specified in Table 62.76. Where the same level is used for both seats and footrests, the width of this level shall be not less than 26 inches.

TABLE 62.76
ROW SPACING REQUIREMENTS

Type of Seating	Minimum Back-to-Back Spacing ¹ (Inches)
Seats without backrests	22
Seats with backrests	30
Chair seating	32

¹All measurements are taken between plumb lines.

(2) FOOTRESTS. Where the same level is not used for both seatboard and footboard, independent footrests shall be provided.

(3) SEATBOARDS AND FOOTBOARDS. (a) Seatboards and footboards (footrests) shall have a minimum width of 9 inches.

(b) All seatboards and footboards shall be fastened in place in such a manner that they cannot be accidentally displaced.

(4) SEAT OCCUPANT WIDTH. The seating capacity shall be established by allowing one sitting or seat to each 18 inches of length.

(5) RISE BETWEEN ROWS. The maximum rise between seat rows shall not exceed 16 inches unless the horizontal row spacing is 40 inches or more.

(6) STEPS. Where the rise between rows exceeds 12 inches, intermediate steps shall be provided the full width of the aisles. Such steps shall have a uniform rise of not more than 8 inches and a tread of not less than 10 inches in width. In no case shall the angle of seating exceed 45 degrees.

(7) OPENINGS. The design of the seatboards and footboards shall be such that a sphere with a diameter larger than 9 inches will not pass from the seating area to the area beneath the seating where seatboards are more than 5 rows above the ground or floor.

History: Cr. Register, December, 1981, No. 312, eff. 1-1-82.

MEANS OF EGRESS

Ch. ILHR 62

GREENHOUSES

ILHR 62.95 Exits. (1) NUMBER OF EXITS. (a) Except as provided in par. (b), every greenhouse shall have at least 2 exits.

(b) Greenhouses with 3,000 or less square feet gross floor area may have one exit.

(2) EXIT DISTRIBUTION. (a) Exits shall be distributed or located so that no part of any greenhouse will be more than 150 feet distant from an exit.

(b) Where an approved automatic fire sprinkler system is provided throughout the greenhouse, the exit distance may be increased to 300 feet.

(3) TYPE OF EXITS. (a) In production greenhouses, at least one-half of the exits required by this section shall be standard exit doors to grade. The other exits may be sliding doors.

(b) In mercantile or teaching greenhouses, the required exits shall be standard exits to grade as specified in s. ILHR 51.15.

History: Cr. Register, December, 1983, No. 336, eff. 1-1-84; emerg. am. (2) (b), eff. 9-6-86; am. (2) (b), Register, November, 1986, No. 371, eff. 12-1-86.

MEANS OF EGRESS

Ch. ILHR 62

PEDESTRIAN ACCESS STRUCTURES

FP ILHR 62.99 Exiting. (1) **NUMBER OF EXITS.** (a) Except as provided in sub. (3), every pedestrian access structure, and every level, other than the open space below the structure, shall be provided with at least one exit.

(2) **TYPE OF EXITS.** (a) Except as provided in par. (b), the exit specified in sub. (1) from the pedestrian access structure shall be an exit door to grade, a stairway to grade constructed as specified in s. ILHR 51.16, or a fire escape to grade constructed as specified in s. ILHR 51.20.

(b) 1. Open stairways or fire escapes may not be used as an exit for any level more than 55 feet above grade.

2. Type "A" fire escapes may terminate on a platform at least 3 feet long, located not more than 10 feet above grade.

(3) **EXCEPTIONS.** The exit specified in sub. (1) from the pedestrian access structure may be omitted providing:

(a) The doors connecting the structure and the building are equipped with exit hardware such that a person can pass from the structure into the building; or

(b) The doors connecting the structure and the building are equipped with hardware that requires a key to pass from the building onto the structure, and that key will also open the door allowing passage from the structure back into the building.

(4) **EXIT DISTANCE.** (a) Except as provided in par. (b), exits shall be distributed or located so that no part of the pedestrian access structure will be more than 200 feet distance from an exit.

(b) Where approved automatic fire sprinklers are provided throughout the pedestrian access structure, an increase in exit distance to 300 feet will be permitted.

History: Cr. Register, August, 1985, No. 356, eff. 1-1-86.

A14.143 TENTS AND AIR SUPPORTED STRUCTURES. The following is a reprint of ch. ILHR 62, Subch. III - Tents:

Subchapter III—Tents

ILHR 62.42 Scope. The requirements of this part shall apply to all tents, except those used exclusively for construction purposes.

History: Cr. Register, January, 1980, No. 289, eff. 2-1-80.

ILHR 62.43 Area limitation and setbacks. (1) **AREA OF GROUND COVERED.** No tent shall be erected to cover more than 75% of the premises on which it is located.

(2) **SETBACK TO PROPERTY LINE AND OTHER STRUCTURES.** (a) Tents used for assembly purposes which cover 1500 square feet or more of ground area shall be located at least 20 feet from any other structure or adjoining property lines.

(b) Concession and other tents not used for assembly purposes need not be separated from each other and may be located less than 20 feet from other structures.

(3) **SETBACK FOR EXITING.** Stake lines of adjacent tents used for assembly purposes shall be sufficient distance from each other to provide an emergency exit passageway not less than 6 feet in width between stake lines. Proper protection shall be provided along such stake lines to eliminate tripping hazards.

History: Cr. Register, January, 1980, No. 289, eff. 2-1-80.

ILHR 62.44 Structural requirements. (1) **MATERIAL SIZE AND STRENGTH.** Poles and other members supporting tents shall be of sufficient size and strength to support the structure safely without exceeding the stresses specified in ch. ILHR 53 of this code.

(2) **WIND LOAD.** (a) All tents shall be adequately guyed, supported and braced to withstand a wind pressure or suction of not less than 10 pounds per square foot.

(b) The poles, guys, stakes, fastenings and similar devices shall be of sufficient strength and so attached as to resist a wind pressure of at least 20 pounds per square foot of projected area of the tent.

History: Cr. Register, January, 1980, No. 289, eff. 2-1-80.

ILHR 62.45 Flame resistance. All tents used for assembly purposes or in which animals are stabled and all other tents used by the public in places of outdoor assembly shall be effectively flameproofed. The owner shall furnish a certificate or a test report by a recognized testing engineer or laboratory as evidence that such tents have the required flame resistance.

History: Cr. Register, January, 1980, No. 289, eff. 2-1-80.

FP ILHR 62.46 Fire hazards. (1) **CLEARING OF GROUND.** The ground enclosed by a tent used in connection with a place of outdoor assembly and for a distance of not less than 10 feet outside such structure on all sides shall be cleared of all flammable material or vegetation which will

Register, August, 1985, No. 356

DEPT. OF INDUSTRY, LABOR & HUMAN RELATIONS 319
Specialty Occupancies ILHR 62

transmit fire. The premises shall be kept free from such flammable material during the period the premises are used by the public.

(2) **COMBUSTIBLE MATERIAL FOR CARE OF ANIMALS.** No hay, straw, shavings or similar combustible materials other than that necessary for the current feeding and care of animals shall be permitted within any tents used for public assembly except that sawdust and shavings may be used if kept damp.

(3) **NO SMOKING.** No smoking or unapproved open flame of any kind shall be permitted in any tent while occupied by the public. "No Smoking" signs shall be conspicuously posted in all tents open to the public.

(4) **SAFETY FILM.** Tents shall not be used for motion picture performances unless safety film is used.

History: Cr. Register, January, 1980, No. 289, eff. 2-1-80.

ILHR 62.47 Exits. (1) **NUMBER OF EXITS.** (a) Every tent occupied by the public shall have at least 2 standard exits located at or near opposite ends of the structure. **FP**

(b) In tents used for assembly purposes, exits shall be provided on 3 sides if the capacity exceeds 600 persons and on 4 sides where the capacity exceeds 1,000 persons.

(2) **EXIT DISTANCE.** Exits shall be uniformly distributed but in no case shall the line of travel to an exit be greater than 150 feet.

(3) **EXIT WIDTH.** The total width of exits from a tent used for assembly purposes shall be not less than 44 inches per 100 persons. Exit openings shall comply in all respects with the requirements of ss. ILHR 51.15 and 55.10 of this code.

History: Cr. Register, January, 1980, No. 289, eff. 2-1-80.

ILHR 62.48 Toilet facilities. Separate toilet facilities, in conjunction with all tents used as places of outdoor assembly, shall be provided in accordance with s. ILHR 55.32. Toilet rooms and equipment shall comply with the requirements of ss. ILHR 52.50-52.64 of this code or as approved by the department.

History: Cr. Register, January, 1980, No. 289, eff. 2-1-80.

ILHR 62.49 Electrical installations. (1) **GENERAL.** Electrical systems in all tents used as places of outdoor assembly shall be installed in accordance with the requirements of the Wisconsin state electrical code, volume 2, ch. ILHR 16. All such systems shall be maintained and operated in a safe and workmanlike manner. **FP**

(2) **PROTECTION AND ISOLATION.** The electrical system and equipment shall be isolated from the public by proper elevation and guarding. All electrical fuses and switches shall be installed in approved enclosures. Cables laid on the ground or in areas traversed by the public shall be placed in trenches or protected by approved covers.

History: Cr. Register, January, 1980, No. 289, eff. 2-1-80.

ILHR 62.50 * Fire extinguishers. (1) **GENERAL.** Portable fire extinguishers shall be installed as specified in Table 62.50. **FP**

*See Appendix A for further explanatory material.

TABLE 62.50

Basic Minimum Extinguisher Rating	Maximum Travel Distance to Extinguisher (feet)	Area to be Protected per Extinguisher (sq. ft.)
1A	75	3,000
2A	75	6,000
3A	75	9,000
4A or larger	75	11,250

(2) LOCATION. (a) Extinguishers shall be conspicuously located where they will be readily accessible and immediately available in the event of fire.

(b) Extinguishers shall not be obstructed or obscured from view.

(3) MAINTENANCE. Portable fire extinguishers shall be maintained as specified in s. ILHR 51.22.

History: Cr. Register, January, 1980, No. 289, eff. 2-1-80; r. and recr., Register, December, 1981, No. 312, eff. 1-1-82.

FP ILHR 62.51 Illumination; exit lights and signs. (1) LIGHTING OF EXITS. All exits, aisles and passageways leading to exits in tents used as places of outdoor assembly shall be kept adequately lighted at all times when the structure is occupied by the public. Artificial illumination having an intensity of not less than 2.5 footcandles at the floor line shall be provided when natural light is inadequate.

(2) ILLUMINATED EXIT SIGNS. Exit lights and signs complying with the requirements of s. ILHR 55.11 shall be provided in all tents used as places of outdoor assembly where more than 100 persons can be accommodated.

A14.159 LUMBER YARD - Fire Extinguishing Equipment.

A14.161 WOODWORKING PLANTS - Fire Protection. The following is a reprint of NFPA Standard 10:

1-4 Classification and ratings of fire extinguishers.

1-4.1 Portable fire extinguishers are classified for use on certain classes of fires and rated for relative extinguishing effectiveness at a temperature of plus 70°F by testing laboratories. This is based upon the preceding classification of fires and the fire-extinguishment potentials as determined by fire tests.

1-4.2 The classification and rating system described in this standard is that used by Underwriters Laboratories, Inc., and Underwriters Laboratories of Canada and is based on extinguishing preplanned fires of determined size and description as follows:

Class A Rating — Wood and excelsior.

Class B Rating — Two-inch depth n-heptane fires in square pans.

Class C Rating — No fire test. Agent must be a nonconductor of electricity.

Class D Rating — Special tests on specific combustible metal fires.

1-5 CLASSIFICATION OF HAZARDS.

1-5.1 Light (low) hazard. Locations where the total amount of Class A combustible materials, including furnishings, decorations and contents, is of minor quantity. These may include buildings or rooms occupied as offices, classrooms, churches, assembly halls, etc. This classification anticipates that the majority of contents items are either noncombustible or so arranged that a fire is not likely to spread rapidly. Small amounts of Class B flammables used for duplicating machines, art departments, etc., are included provided that they are kept in closed containers and safely stored.

1-5.2 Ordinary (moderate) hazard. Locations where the total amount of Class A combustibles and Class B flammables are present in greater amounts than expected under light (low) hazard occupancies. These occupancies could consist of offices, classrooms, mercantile shops and allied storage, light manufacturing, research operations, auto showrooms, parking garages, workshop or support service areas of light (low) hazard occupancies and warehouses containing Class I or Class II commodities as defined by NFPA 231, Standard for Indoor General Storage.

1-5.3 Extra (high) hazard. Locations where the total amount of Class A combustibles and Class B flammables are present, in storage, production use and/or finished product over and above those expected and classed as ordinary (moderate) hazards. These occupancies could consist of woodworking, vehicle repair, aircraft and boat servicing, individual product display showrooms, product convention center displays, storage and manufacturing processes such as painting, dipping, coating, including flammable liquid handling. Also included is warehousing of, or in-process storage of other than Class I and Class II commodities.

3-2 FIRE EXTINGUISHER SIZE AND PLACEMENT FOR CLASS A HAZARDS.

3-2.1 Minimal sizes of fire extinguishers for the listed grades of hazards shall be provided on the basis of Table 3-2.1 except as modified by 3-2.3. Extinguishers shall be located so that the maximum travel distances shall not exceed those specified in Table 3-2.1, except as modified by 3-2.3.

3-2.1.1 Certain smaller extinguishers which are charged with multipurpose dry chemical or Halon 1211 are rated on Class B and Class C fires, but have insufficient effectiveness to earn the minimum 1-A rating even though they have value in extinguishing smaller Class A fires. They shall not be used to meet the requirements of 3-2.1.

3-2.2 Up to one-half of the complement of extinguishers as specified in Table 3-2.1 may be replaced by uniformly spaced 1½ inch hose stations for use by the occupants of the building. When hose stations are so provided they shall conform to NFPA 14, Installation of Standpipe and Hose Systems. The location of hose stations and the placement of fire extinguishers shall be in such a manner that the hose stations do not replace more than every other extinguisher.

3-2.3 Where the floor area of a building is less than that specified in Table 3-2.1, at least one extinguisher of the minimum size recommended shall be provided.

3-2.4 The protection requirements may be fulfilled with extinguishers of higher rating provided the travel distance to such larger extinguishers shall not exceed 75 feet.

Table 3-2.1

	Light (Low) Hazard Occupancy	Ordinary (Moderate) Hazard Occupancy	Extra (High) Hazard Occupancy
Minimum rated single extinguisher	2-A	2-A	4-A
Maximum floor area per unit of A	3,000 sq. ft.	1,500 sq. ft.	1,000 sq. ft.
Maximum floor area for extinguisher	11,250 sq. ft.	11,250 sq. ft.	11,250 sq. ft.
Maximum travel distance to extinguisher	75 ft.	75 ft.	75 ft.

*Two 2½ gal water type extinguishers can be used to fulfill the requirements of one 4-A rated extinguisher.

A14.174 WELDING OR CUTTING, CALCIUM CARBIDE AND ACETYLENE GENERATORS.
The following is a reprint of Subpart Q of 29CFR1910:

§ 1910.245

§ 1910.245 Effective dates.

(a) The provisions of this Subpart P shall become effective on August 27, 1971, except as provided in the remaining paragraphs of this section.

(b) The following provisions shall become effective on February 15, 1972:

§ 1910.243 (a)(1), (a)(2), (a)(3), (b)(1), (c)(1), (c)(2), (c)(3), (d)(1), (d)(2), and (e).

(c) Notwithstanding anything in paragraph (a), (b), or (d) of this section, any provision in any other section of this subpart which contains in itself a specific effective date or time limitation shall become effective on such date or shall apply in accordance with such limitation.

(d) Notwithstanding anything in paragraph (a) of this section, if any standard in 41 CFR Part 50-204, other than a national consensus standard incorporated by reference in § 50-204.2 (a)(1), is or becomes applicable at any time to any employment and place of employment, by virtue of the Walsh-Healey Public Contracts Act, or the Service Contract Act of 1965, or the National Foundation on Arts and Humanities Act of 1965, any corresponding established Federal standard in this Subpart P which is derived from 41 CFR Part 50-204 shall also become effective, and shall be applicable to such employment and place of employment, on the same date.

§ 1910.246 Sources of standards.

Sec.	Source
1910.241(a)	ANSI A10.3 (1970), Safety Requirements for Explosive Actuated Fastening Tools.
1910.241(b)	ANSI B7.1-1970, Safety Code for the Use, Care, and Protection of Abrasive Wheels.
1910.241(c)	ANSI B71.1-1968, Safety Specifications for Power Lawn Mowers.
1910.241(d)	ANSI B30.1-1943, Safety Code for Jacks.
1910.242	41 CFR 50-204.4 and 50-204.8.
1910.243(a)	ANSI O1.1-1954 (R1961), Safety Code for Woodworking Machines.
1910.243(b)	ANSI B19.1-1938, Compressed Air Machinery and Equipment.
1910.243(c)	ANSI B7.1-1970, Safety Code for the Use, Care, and Protection of Abrasive Wheels.
1910.243(d)	ANSI A10.3-1970, Explosive Actuated Fastening Tools.
1910.243(e)	ANSI B71-1968, Safety Specifications for Power Lawn Mowers.

29 CFR Ch. XVII (7-1-85 Edition)

Sec.	Source
1910.244(a)	ANSI B30.1-1943, (R1952), Safety Code for Jacks.
1910.244(b)	ANSI Z9.4-1968, Ventilation and Safe Practices of Abrasive Blasting Operations.

§ 1910.247 Standards organizations.

Specific standards of the following organization have been referenced in this subpart. Copies of the referenced materials may be obtained from the issuing organization.

American National Standards Institute, 1430 Broadway, New York, N.Y. 10018.

Subpart Q—Welding, Cutting, and Brazing

§ 1910.251 Definitions.

As used in this subpart:

(a) "Welder" and "welding operator" mean any operator of electric or gas welding and cutting equipment.

(b) "Approved" means listed or approved by a nationally recognized testing laboratory, such as Factory Mutual Engineering Corp., or Underwriters' Laboratories, Inc.

(c) All other welding terms are used in accordance with American Welding Society—Terms and Definitions—A3.0-1969.

§ 1910.252 Welding, cutting, and brazing.

(a) *Installation and operation of oxygen-fuel gas systems for welding and cutting—(1) General requirements.* (i) *Flammable mixture.* Mixtures of fuel gases and air or oxygen may be explosive and shall be guarded against. No device or attachment facilitating or permitting mixtures of air or oxygen with flammable gases prior to consumption, except at the burner or in a standard torch, shall be allowed unless approved for the purpose.

(ii) *Maximum pressure.* Under no condition shall acetylene be generated, piped (except in approved cylinder manifolds) or utilized at a pressure in excess of 15 p.s.i. gage pressure of 30 p.s.i. absolute pressure. (The 30 p.s.i. absolute pressure limit is intended to prevent unsafe use of acetylene in

Occupational Safety and Health Admin., Labor

§ 1910.252

pressurized chambers such as caissons, underground excavations or tunnel construction.) This requirement is not intended to apply to storage of acetylene dissolved in a suitable solvent in cylinders manufactured and maintained according to U.S. Department of Transportation requirements, or to acetylene for chemical use. The use of liquid acetylene shall be prohibited.

(iii) *Apparatus.* Only approved apparatus such as torches, regulators or pressure-reducing valves, acetylene generators, and manifolds shall be used.

(iv) *Personnel.* Workmen in charge of the oxygen or fuel-gas supply equipment, including generators, and oxygen or fuel-gas distribution piping systems shall be instructed and judged competent by their employers for this important work before being left in charge. Rules and instructions covering the operation and maintenance of oxygen or fuel-gas supply equipment including generators, and oxygen or fuel-gas distribution piping systems shall be readily available.

(2) *Cylinders and containers—(i) Approval and marking.* (a) All portable cylinders used for the storage and shipment of compressed gases shall be constructed and maintained in accordance with the regulations of the U.S. Department of Transportation, 49 CFR Parts 171-179.

(b) Compressed gas cylinders shall be legibly marked, for the purpose of identifying the gas content, with either the chemical or the trade name of the gas. Such marking shall be by means of stenciling, stamping, or labeling, and shall not be readily removable. Whenever practical, the marking shall be located on the shoulder of the cylinder. This method conforms to the American National Standard Method for Marking Portable Compressed Gas Containers to Identify the Material Contained, ANSI Z48.1-1954.

(c) Compressed gas cylinders shall be equipped with connections complying with the American National Standard Compressed Gas Cylinder Valve Outlet and Inlet Connections, ANSI B57.1-1965.

(d) All cylinders with a water weight capacity of over 30 pounds shall be equipped with means of connecting a

valve protection cap or with a collar or recess to protect the valve.

(ii) *Storage of cylinders—general.* (a) Cylinders shall be kept away from radiators and other sources of heat.

(b) Inside of buildings, cylinders shall be stored in a well-protected, well-ventilated, dry location, at least 20 feet from highly combustible materials such as oil or excelsior. Cylinders should be stored in definitely assigned places away from elevators, stairs, or gangways. Assigned storage spaces shall be located where cylinders will not be knocked over or damaged by passing or falling objects, or subject to tampering by unauthorized persons. Cylinders shall not be kept in unventilated enclosures such as lockers and cupboards.

(c) Empty cylinders shall have their valves closed.

(d) Valve protection caps, where cylinder is designed to accept a cap, shall always be in place, hand-tight, except when cylinders are in use or connected for use.

(iii) *Fuel-gas cylinder storage.* Inside a building, cylinders, except those in actual use or attached ready for use, shall be limited to a total gas capacity of 2,000 cubic feet or 300 pounds of liquefied petroleum gas.

(a) For storage in excess of 2,000 cubic feet total gas capacity of cylinders or 300 pounds of liquefied petroleum gas, a separate room or compartment conforming to the requirements specified in paragraphs (6) (vi)(a) (8) and (9) of this paragraph shall be provided, or cylinders shall be kept outside or in a special building. Special buildings, rooms or compartments shall have no open flame for heating or lighting and shall be well ventilated. They may also be used for storage of calcium carbide in quantities not to exceed 600 pounds, when contained in metal containers complying with paragraphs (a)(7)(i) (a) and (b) of this paragraph.

(b) Acetylene cylinders shall be stored valve end up.

(iv) *Oxygen storage.* (a) Oxygen cylinders shall not be stored near highly combustible material, especially oil and grease; or near reserve stocks of carbide and acetylene or other fuel-gas cylinders, or near any other substance

§ 1910.252

29 CFR Ch. XVII (7-1-85 Edition)

likely to cause or accelerate fire; or in an acetylene generator compartment.

(b) Oxygen cylinders stored in outside generator houses shall be separated from the generator or carbide storage rooms by a noncombustible partition having a fire-resistance rating of at least 1 hour. This partition shall be without openings and shall be gas-tight.

(c) Oxygen cylinders in storage shall be separated from fuel-gas cylinders or combustible materials (especially oil or grease), a minimum distance of 20 feet or by a noncombustible barrier at least 5 feet high having a fire-resistance rating of at least one-half hour.

(d) Where a liquid oxygen system is to be used to supply gaseous oxygen for welding or cutting and the system has a storage capacity of more than 13,000 cubic feet of oxygen (measured at 14.7 p.s.i.a. and 70° F.), connected in service or ready for service, or more than 25,000 cubic feet of oxygen (measured at 14.7 p.s.i.a. and 70° F.), including unconnected reserves on hand at the site, it shall comply with the provisions of the Standard for Bulk Oxygen Systems at Consumer Sites, NFPA No. 566-1965.

(v) *Operating procedures.* (a) Cylinders, cylinder valves, couplings, regulators, hose, and apparatus shall be kept free from oily or greasy substances. Oxygen cylinders or apparatus shall not be handled with oily hands or gloves. A jet of oxygen must never be permitted to strike an oily surface, greasy clothes, or enter a fuel oil or other storage tank.

(b) (1) When transporting cylinders by a crane or derrick, a cradle, boat, or suitable platform shall be used. Slings or electric magnets shall not be used for this purpose. Valve-protection caps, where cylinder is designed to accept a cap, shall always be in place.

(2) Cylinders shall not be dropped or struck or permitted to strike each other violently.

(3) Valve-protection caps shall not be used for lifting cylinders from one vertical position to another. Bars shall not be used under valves or valve-protection caps to pry cylinders loose when frozen to the ground or otherwise fixed; the use of warm (not boiling) water is recommended. Valve-pro-

tection caps are designed to protect cylinder valves from damage.

(4) Unless cylinders are secured on a special truck, regulators shall be removed and valve-protection caps, when provided for, shall be put in place before cylinders are moved.

(5) Cylinders not having fixed hand wheels shall have keys, handles, or nonadjustable wrenches on valve stems while these cylinders are in service. In multiple cylinder installations only one key or handle is required for each manifold.

(6) Cylinder valves shall be closed before moving cylinders.

(7) Cylinder valves shall be closed when work is finished.

(8) Valves of empty cylinders shall be closed.

(9) Cylinders shall be kept far enough away from the actual welding or cutting operation so that sparks, hot slag, or flame will not reach them, or fire-resistant shields shall be provided.

(10) Cylinders shall not be placed where they might become part of an electric circuit. Contacts with third rails, trolley wires, etc., shall be avoided. Cylinders shall be kept away from radiators, piping systems, layout tables, etc., that may be used for grounding electric circuits such as for arc welding machines. Any practice such as the tapping of an electrode against a cylinder to strike an arc shall be prohibited.

(11) Cylinders shall never be used as rollers or supports, whether full or empty.

(12) The numbers and markings stamped into cylinders shall not be tampered with.

(13) No person, other than the gas supplier, shall attempt to mix gases in a cylinder. No one, except the owner of the cylinder or person authorized by him, shall refill a cylinder.

(14) No one shall tamper with safety devices in cylinders or valves.

(15) Cylinders shall not be dropped or otherwise roughly handled.

(16) Unless connected to a manifold, oxygen from a cylinder shall not be used without first attaching an oxygen regulator to the cylinder valve. Before connecting the regulator to the cylinder valve, the valve shall be opened

Occupational Safety and Health Admin., Labor

§ 1910.252

slightly for an instant and then closed. Always stand to one side of the outlet when opening the cylinder valve.

(17) A hammer or wrench shall not be used to open cylinder valves. If valves cannot be opened by hand, the supplier shall be notified.

(18) (i) Cylinder valves shall not be tampered with nor should any attempt be made to repair them. If trouble is experienced, the supplier should be sent a report promptly indicating the character of the trouble and the cylinder's serial number. Supplier's instructions as to its disposition shall be followed.

(ii) Complete removal of the stem from a diaphragm-type cylinder valve shall be avoided.

(c) (1) Fuel-gas cylinders shall be placed with valve end up whenever they are in use. Liquefied gases shall be stored and shipped with the valve end up.

(2) Cylinders shall be handled carefully. Rough handling, knocks, or falls are liable to damage the cylinder, valve or safety devices and cause leakage.

(3) Before connecting a regulator to a cylinder valve, the valve shall be opened slightly and closed immediately. The valve shall be opened while standing to one side of the outlet; never in front of it. Never crack a fuel-gas cylinder valve near other welding work or near sparks, flame, or other possible sources of ignition.

(4) Before a regulator is removed from a cylinder valve, the cylinder valve shall be closed and the gas released from the regulator.

(5) Nothing shall be placed on top of an acetylene cylinder when in use which may damage the safety device or interfere with the quick closing of the valve.

(6) If cylinders are found to have leaky valves or fittings which cannot be stopped by closing of the valve, the cylinders shall be taken outdoors away from sources of ignition and slowly emptied.

(7) A warning should be placed near cylinders having leaking fuse plugs or other leaking safety devices not to approach them with a lighted cigarette or other source of ignition. Such cylinders should be plainly tagged; the sup-

plier should be promptly notified and his instructions followed as to their return.

(8) Safety devices shall not be tampered with.

(9) Fuel-gas shall never be used from cylinders through torches or other devices equipped with shutoff valves without reducing the pressure through a suitable regulator attached to the cylinder valve or manifold.

(10) The cylinder valve shall always be opened slowly.

(11) An acetylene cylinder valve shall not be opened more than one and one-half turns of the spindle, and preferably no more than three-fourths of a turn.

(12) Where a special wrench is required it shall be left in position on the stem of the valve while the cylinder is in use so that the fuel-gas flow can be quickly turned off in case of emergency. In the case of manifolded or coupled cylinders at least one such wrench shall always be available for immediate use.

(3) *Manifolding of cylinders*—(1) *Fuel-gas manifolds.* (a) Manifolds shall be approved either separately for each component part or as an assembled unit.

(b) Except as provided in paragraph (a)(3)(i)(c) of this section fuel-gas cylinders connected to one manifold inside a building shall be limited to a total capacity not exceeding 300 pounds of liquefied petroleum gas or 3,000 cubic feet of other fuel-gas. More than one such manifold with connected cylinders may be located in the same room provided the manifolds are at least 50 feet apart or separated by a noncombustible barrier at least 5 feet high having a fire-resistance rating of at least one-half hour.

(c) Fuel-gas cylinders connected to one manifold having an aggregate capacity exceeding 300 pounds of liquefied petroleum gas or 3,000 cubic feet of other fuel-gas shall be located outdoors, or in a separate building or room constructed in accordance with paragraphs (a)(6)(vi)(a) (8) and (9) of this section.

(d) Separate manifold buildings or rooms may also be used for the storage of drums of calcium carbide and cylinders containing fuel gases as pro-

§ 1910.252

29 CFR Ch. XVII (7-1-85 Edition)

vided in paragraph (a)(2)(iii) of this section. Such buildings or rooms shall have no open flames for heating or lighting and shall be well-ventilated.

(e) High-pressure fuel-gas manifolds shall be provided with approved pressure regulating devices.

(ii) *High-pressure oxygen manifolds for use with cylinders having a Department of Transportation service pressure above 200 p.s.i.g.*. (a) Manifolds shall be approved either separately for each component part or as an assembled unit.

(b) Oxygen manifolds shall not be located in an acetylene generator room. Oxygen manifolds shall be separated from fuel-gas cylinders or combustible materials (especially oil or grease), a minimum distance of 20 feet or by a noncombustible barrier at least 5 feet high having a fire-resistance rating of at least one-half hour.

(c) Except as provided in subdivision (d) of this subdivision oxygen cylinders connected to one manifold shall be limited to a total gas capacity of 6,000 cubic feet. More than one such manifold with connected cylinders may be located in the same room provided the manifolds are at least 50 feet apart or separated by a noncombustible barrier at least 5 feet high having a fire-resistance rating of at least one-half hour.

(d) An oxygen manifold, to which cylinders having an aggregate capacity of more than 6,000 cubic feet of oxygen are connected, should be located outdoors or in a separate noncombustible building. Such a manifold, if located inside a building having other occupancy, shall be located in a separate room of noncombustible construction having a fire-resistance rating of at least one-half hour or in an area with no combustible material within 20 feet of the manifold.

(e) An oxygen manifold or oxygen bulk supply system which has storage capacity of more than 13,000 cubic feet of oxygen (measured at 14.7 p.s.i.a. and 70° F.), connected in service or ready for service, or more than 25,000 cubic feet of oxygen (measured at 14.7 p.s.i.a. and 70° F.), including unconnected reserves on hand at the site, shall comply with the provisions of the Standard for Bulk Oxygen Sys-

tems at Consumer Sites, NFPA No. 566-1965.

(f) High-pressure oxygen manifolds shall be provided with approved pressure-regulating devices.

(iii) *Low-pressure oxygen manifolds for use with cylinders having a Department of Transportation service pressure not exceeding 200 p.s.i.g.*. (a) Manifolds shall be of substantial construction suitable for use with oxygen at a pressure of 250 p.s.i.g. They shall have a minimum bursting pressure of 1,000 p.s.i.g. and shall be protected by a safety relief device which will relieve at a maximum pressure of 500 p.s.i.g. DOT-4L200 cylinders have safety devices which relieve at a maximum pressure of 250 p.s.i.g. (or 235 p.s.i.g. if vacuum insulation is used).

(b) Hose and hose connections subject to cylinder pressure shall comply with paragraph (a)(5)(v) of this section. Hose shall have a minimum bursting pressure of 1,000 p.s.i.g.

(c) The assembled manifold including leads shall be tested and proven gas-tight at a pressure of 300 p.s.i.g. The fluid used for testing oxygen manifolds shall be oil-free and not combustible.

(d) The location of manifolds shall comply with subdivisions (ii) (b), (c), (d), and (e) of this subdivision.

(e) The following sign shall be conspicuously posted at each manifold:

Low-Pressure Manifold

Do Not Connect High-Pressure Cylinders

Maximum Pressure—250 P.S.I.G.

(iv) *Portable outlet headers.* (a) Portable outlet headers shall not be used indoors except for temporary service where the conditions preclude a direct supply from outlets located on the service piping system.

(b) Each outlet on the service piping from which oxygen or fuel-gas is withdrawn to supply a portable outlet header shall be equipped with a readily accessible shutoff valve.

(c) Hose and hose connections used for connecting the portable outlet header to the service piping shall comply with paragraph (a)(5)(v) of this section.

(d) Master shutoff valves for both oxygen and fuel-gas shall be provided

at the entry end of the portable outlet header.

(e) Portable outlet headers for fuel-gas service shall be provided with an approved hydraulic back-pressure valve installed at the inlet and preceding the service outlets, unless an approved pressure-reducing regulator, an approved back-flow check valve, or an approved hydraulic back-pressure valve is installed at each outlet. Outlets provided on headers for oxygen service may be fitted for use with pressure-reducing regulators or for direct hose connection.

(f) Each service outlet on portable outlet headers shall be provided with a valve assembly that includes a detachable outlet seal cap, chained or otherwise attached to the body of the valve.

(g) Materials and fabrication procedures for portable outlet headers shall comply with paragraphs (a)(4) (i), (ii), and (v) of this section.

(h) Portable outlet headers shall be provided with frames which will support the equipment securely in the correct operating position and protect them from damage during handling and operation.

(v) *Manifold operating procedures.* (a) Cylinder manifolds shall be installed under the supervision of someone familiar with the proper practices with reference to their construction and use.

(b) All component parts used in the methods of manifolding described in subdivision (i) of this subdivision shall be approved as to materials, design and construction either separately or as an assembled unit.

(c) All manifolds and parts used in methods of manifolding shall be used only for the gas or gases for which they are approved.

(d) When acetylene cylinders are coupled, approved flash arresters shall be installed between each cylinder and the coupler block. For outdoor use only, and when the number of cylinders coupled does not exceed three, one flash arrester installed between the coupler block and regulator is acceptable.

(e) [Reserved]

(f) The aggregate capacity of fuel-gas cylinders connected to a portable

manifold inside a building shall not exceed 3,000 cubic feet of gas.

(g) Acetylene and liquefied fuel-gas cylinders shall be manifolded in a vertical position.

(h) The pressure in the gas cylinders connected to and discharged simultaneously through a common manifold shall be approximately equal.

(4) *Service piping systems*—(i) *Materials and design.* (a) (1) Piping and fittings shall comply with Section 2, Industrial Gas and Air Piping Systems, of the American National Standard Code for Pressure Piping ANSI B31.1, 1967, insofar as it does not conflict with paragraph (a)(4)(i)(a)(1) (i) and (ii) of this subdivision:

(i) Pipe shall be at least Schedule 40 and fittings shall be at least standard weight in sizes up to and including 6-inch nominal.

(ii) Copper tubing shall be Types K or L in accordance with the Standard Specification for Seamless Copper Water Tube, ASTM B88-66a.

(2) Piping shall be steel, wrought iron, brass or copper pipe, or seamless copper, brass or stainless steel tubing, except as provided in paragraph (a)(4)(i) (b) and (c) of this paragraph.

(b) (1) Oxygen piping and fittings at pressures in excess of 700 p.s.i.g., shall be stainless steel or copper alloys.

(2) Hose connections and hose complying with paragraph (a)(5)(v) of this section may be used to connect the outlet of a manifold pressure regulator to piping providing the working pressure of the piping is 250 p.s.i.g. or less and the length of the hose does not exceed 5 feet. Hose shall have a minimum bursting pressure of 1,000 p.s.i.g.

(3) When oxygen is supplied to a service piping system from a low-pressure oxygen manifold without an intervening pressure regulating device, the piping system shall have a minimum design pressure of 250 p.s.i.g. A pressure regulating device shall be used at each station outlet when the connected equipment is for use at pressures less than 250 p.s.i.g.

(c) (1) Piping for acetylene or acetylenic compounds shall be steel or wrought iron.

(2) Unalloyed copper shall not be used for acetylene or acetylenic compounds except in listed equipment.

§ 1910.252

29 CFR Ch. XVII (7-1-85 Edition)

(ii) *Piping joints.* (a) Joints in steel or wrought iron piping shall be welded, threaded or flanged. Fittings, such as ells, tees, couplings, and unions, may be rolled, forged or cast steel, malleable iron or nodular iron. Gray or white cast iron fittings are prohibited.

(b) Joints in brass or copper pipe shall be welded, brazed, threaded, or flanged. If of the socket type, they shall be brazed with silver-brazing alloy or similar high melting point (not less than 800° F.) filler metal.

(c) Joints in seamless copper, brass, or stainless steel tubing shall be approved gas tubing fittings or the joints shall be brazed. If of the socket type, they shall be brazed with silver-brazing alloy or similar high melting point (not less than 800° F.) filler metal.

(iii) *Installation.* (a) Distribution lines shall be installed and maintained in a safe operating condition.

(b) All piping shall be run as directly as practicable, protected against physical damage, proper allowance being made for expansion and contraction, jarring and vibration. Pipe laid underground in earth shall be located below the frost line and protected against corrosion. After assembly, piping shall be thoroughly blown out with air, nitrogen, or carbon dioxide to remove foreign materials. For oxygen piping, only oil-free air, oil-free nitrogen, or oil-free carbon dioxide shall be used.

(c) Only piping which has been welded or brazed shall be installed in tunnels, trenches or ducts. Shutoff valves shall be located outside such conduits. Oxygen piping may be placed in the same tunnel, trench or duct with fuel-gas pipelines, provided there is good natural or forced ventilation.

(d) Low points in piping carrying moist gas shall be drained into drip pots constructed so as to permit pumping or draining out the condensate at necessary intervals. Drain valves shall be installed for this purpose having outlets normally closed with screw caps or plugs. No open end valves or petcocks shall be used, except that in drips located out of doors, underground, and not readily accessible, valves may be used at such points if they are equipped with means to

secure them in the closed position. Pipes leading to the surface of the ground shall be cased or jacketed where necessary to prevent loosening or breaking.

(e) Gas cocks or valves shall be provided for all buildings at points where they will be readily accessible for shutting off the gas supply to these buildings in any emergency. There shall also be provided a shutoff valve in the discharge line from the generator, gas holder, manifold or other source of supply.

(f) Shutoff valves shall not be installed in safety relief lines in such a manner that the safety relief device can be rendered ineffective.

(g) Fittings and lengths of pipe shall be examined internally before assembly and, if necessary freed from scale or dirt. Oxygen piping and fittings shall be washed out with a suitable solution which will effectively remove grease and dirt but will not react with oxygen. Hot water solutions of caustic soda or trisodium phosphate are effective cleaning agents for this purpose.

(h) Piping shall be thoroughly blown out after assembly to remove foreign materials. For oxygen piping, oil-free air, oil-free nitrogen, or oil-free carbon dioxide shall be used. For other piping, air or inert gas may be used.

(i) When flammable gas lines or other parts of equipment are being purged of air or gas, open lights or other sources of ignition shall not be permitted near uncapped openings.

(j) No welding or cutting shall be performed on an acetylene or oxygen pipeline, including the attachment of hangers or supports, until the line has been purged. Only oil-free air, oil-free nitrogen, or oil-free carbon dioxide shall be used to purge oxygen lines.

(iv) *Painting and signs.* (a) Underground pipe and tubing and outdoor ferrous pipe and tubing shall be covered or painted with a suitable material for protection against corrosion.

(b) Aboveground piping systems shall be marked in accordance with the American National Standard Scheme for the Identification of Piping Systems, ANSI A13.1-1956.

(c) Station outlets shall be marked to indicate the name of the gas.

(v) *Testing.* (a) Piping systems shall be tested and proved gastight at 1½ times the maximum operating pressure, and shall be thoroughly purged of air before being placed in service. The material used for testing oxygen lines shall be oil free and noncombustible. Flames shall not be used to detect leaks.

(b) When flammable gas lines or other parts of equipment are being purged of air or gas, sources of ignition shall not be permitted near uncapped openings.

(5) *Protective equipment, hose, and regulators—(i) General.* Equipment shall be installed and used only in the service for which it is approved and as recommended by the manufacturer.

(ii) *Pressure relief devices.* Service piping systems shall be protected by pressure relief devices set to function at not more than the design pressure of the systems and discharging upwards to a safe location.

(iii) *Piping protective equipment.* (a) The fuel-gas and oxygen piping systems, including portable outlet headers shall incorporate the protective equipment shown in Figures Q-1, Q-2, and Q-3.

(3) Excessive back pressure of oxygen in the fuel-gas supply system. The three functions of the protective equipment may be combined in one device or may be provided by separate devices.

(i) The protective equipment shall be located in the main supply line, as in Figure Q-1 or at the head of each branch line, as in Figure Q-2 or at each location where fuel-gas is withdrawn, as in Figure Q-3. Where branch lines are of 2-inch pipe size or larger or of substantial length, protective equipment (designated as P_f) shall be located as shown in either Q-2 and Q-3.

(ii) Backflow protection shall be provided by an approved device that will prevent oxygen from flowing into the fuel-gas system or fuel from flowing into the oxygen system (see S_p, Figs. Q-1 and Q-2)

(iii) Flash-back protection shall be provided by an approved device that will prevent flame from passing into the fuel-gas system.

(iv) Back-pressure protection shall be provided by an approved pressure-relief device set at a pressure not greater than the pressure rating of the backflow or the flashback protection device, whichever is lower. The pressure-relief device shall be located on the downstream side of the backflow and flashback protection devices. The vent from the pressure-relief device shall be at least as large as the relief device inlet and shall be installed without low points that may collect moisture. If low points are unavoidable, drip pots with drains closed with screw plugs or caps shall be installed at the low points. The vent terminus shall not endanger personnel or property through gas discharge; shall be located away from ignition sources; and shall terminate in a hood or bend.

(c) If pipeline protective equipment incorporates a liquid, the liquid level shall be maintained, and a suitable antifreeze may be used to prevent freezing.

(d) Fuel gas for use with equipment not requiring oxygen shall be withdrawn upstream of the piping protective devices.

(iv) *Station outlet protective equipment.* (a) A check valve, pressure regu-

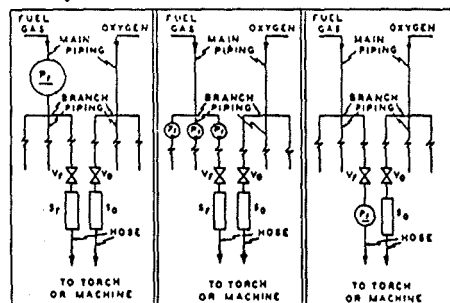

Fig. Q-1 Fig. Q-2 Fig. Q-3
 LEGEND
 P_f — Protective equipment in fuel gas piping
 V_f — Fuel gas station outlet valve
 V_o — Oxygen station outlet valve
 B_f — Backflow prevention device(s) at fuel gas station outlet
 B_o — Backflow prevention device(s) at oxygen station outlet

When only a portion of a fuel-gas system is to be used with oxygen, only that portion need comply with paragraph (a)(5)(iii)(a) of this paragraph.

(b) Approved protective equipment (designated P_f in Figs. Q-1, Q-2, and Q-3) shall be installed in fuel-gas piping to prevent:

(1) Backflow of oxygen into the fuel-gas supply system;

(2) Passage of a flash back into the fuel-gas supply system; and

§ 1910.252

29 CFR Ch. XVII (7-1-85 Edition)

lator, hydraulic seal, or combination of these devices shall be provided at each station outlet, including those on portable headers, to prevent backflow, as shown in Figures Q-1, Q-2, and Q-3 and designated as S_p and S_o.

(b) When approved pipeline protective equipment (designated P_p) is located at the station outlet as in Figure Q-3, no additional check valve, pressure regulator, or hydraulic seal is required.

(c) A shutoff valve (designated V_p and V_o) shall be installed at each station outlet and shall be located on the upstream side of other station outlet equipment.

(d) If the station outlet is equipped with a detachable regulator, the outlet shall terminate in a union connection that complies with the Regulator Connection Standards, 1958, Compressed Gas Association.

(e) If the station outlet is connected directly to a hose, the outlet shall terminate in a union connection complying with the Standard Hose Connection Specifications, 1957, Compressed Gas Association.

(f) Station outlets may terminate in pipe threads to which permanent connections are to be made, such as to a machine.

(g) Station outlets shall be equipped with a detachable outlet seal cap secured in place. This cap shall be used to seal the outlet except when a hose, a regulator, or piping is attached.

(h) Where station outlets are equipped with approved backflow and flashback protective devices, as many as four torches may be supplied from one station outlet through rigid piping, provided each outlet from such piping is equipped with a shutoff valve and provided the fuel-gas capacity of any one torch does not exceed 15 cubic feet per hour.

This subdivision does not apply to machines.

(v) *Hose and hose connections.* (a) Hose for oxy-fuel gas service shall comply with the Specification for Rubber Welding Hose, 1958, Compressed Gas Association and Rubber Manufacturers Association.

(b) [Reserved]

(c) When parallel lengths of oxygen and acetylene hose are taped together

for convenience and to prevent tangling, not more than 4 inches out of 12 inches shall be covered by tape.

(d) Hose connections shall comply with the Standard Hose Connection Specifications, 1957, Compressed Gas Association.

(e) Hose connections shall be clamped or otherwise securely fastened in a manner that will withstand, without leakage, twice the pressure to which they are normally subjected in service, but in no case less than a pressure of 300 p.s.i. Oil-free air or an oil-free inert gas shall be used for the test.

(f) Hose showing leaks, burns, worn places, or other defects rendering it unfit for service shall be repaired or replaced.

(vi) *Pressure-reducing regulators.* (a) Pressure-reducing regulators shall be used only for the gas and pressures for which they are intended. The regulator inlet connections shall comply with Regulator Connection Standards, 1958, Compressed Gas Association.

(b) When regulators or parts of regulators, including gages, need repair, the work shall be performed by skilled mechanics who have been properly instructed.

(c) Gages on oxygen regulators shall be marked "USE NO OIL."

(d) Union nuts and connections on regulators shall be inspected before use to detect faulty seats which may cause leakage of gas when the regulators are attached to the cylinder valves.

(6) *Acetylene generators—(i) Approval and marking.* (a) Generators shall be of approved construction and shall be plainly marked with the maximum rate of acetylene in cubic feet per hour for which they are designed; the weight and size of carbide necessary for a single charge; the manufacturer's name and address; and the name or number of the type of generator.

(b) Carbide shall be of the size marked on the generator nameplate.

(ii) *Rating and pressure limitations.* (a) The total hourly output of a generator shall not exceed the rate for which it is approved and marked. Unless specifically approved for higher ratings, carbide-feed generators shall be rated at 1 cubic foot per hour

Occupational Safety and Health Admin., Labor

§ 1910.252

per pound of carbide required for a single complete charge.

(b) Relief valves shall be regularly operated to insure proper functioning. Relief valves for generating chambers shall be set to open at a pressure not in excess of 15 p.s.i.g. Relief valves for hydraulic back pressure valves shall be set to open at a pressure not in excess of 20 p.s.i.g.

(c) Nonautomatic generators shall not be used for generating acetylene at pressures exceeding 1 p.s.i.g., and all water overflows shall be visible.

(iii) *Location.* The space around the generator shall be ample for free, unobstructed operation and maintenance and shall permit ready adjustment and charging.

(iv) *Stationary acetylene generators (automatic and nonautomatic).* (a) (1) The foundation shall be so arranged that the generator will be level and so that no excessive strain will be placed on the generator or its connections. Acetylene generators shall be grounded.

(2) Generators shall be placed where water will not freeze. The use of common salt (sodium chloride) or other corrosive chemicals for protection against freezing is not permitted. (For heating systems see paragraph (a)(6)(vi)(c) of this section.)

(3) Except when generators are prepared in accordance with paragraph (a)(6)(vii)(e) of this section, sources of ignition shall be prohibited in outside generator houses or inside generator rooms.

(4) Water shall not be supplied through a continuous connection to the generator except when the generator is provided with an adequate open overflow or automatic water shutoff which will effectively prevent overflowing of the generator. Where a noncontinuous connection is used, the supply line shall terminate at a point not less than 2 inches above the regularly provided opening for filling so that the water can be observed as it enters the generator.

(5) Unless otherwise specifically approved, generators shall not be fitted with continuous drain connections leading to sewers, but shall discharge through an open connection into a suitably vented outdoor receptacle or

residue pit which may have such connections. An open connection for the sludge drawoff is desirable to enable the generator operator to observe leakage of generating water from the drain valve or sludge cock.

(b) (1) Each generator shall be provided with a vent pipe.

(2) The escape or relief pipe shall be rigidly installed without traps and so that any condensation will drain back to the generator.

(3) The escape or relief pipe shall be carried full size to a suitable point outside the building. It shall terminate in a hood or bend located at least 12 feet above the ground, preferably above the roof, and as far away as practicable from windows or other openings into buildings and as far away as practicable from sources of ignition such as flues or chimneys and tracks used by locomotives. Generating chamber relief pipes shall not be inter-connected but shall be separately led to the outside air. The hood or bend shall be so constructed that it will not be obstructed by rain, snow, ice, insects, or birds. The outlet shall be at least 3 feet from combustible construction.

(c) (1) Gas holders shall be constructed on the gasometer principle, the bell being suitably guided. The gas bell shall move freely without tendency to bind and shall have a clearance of at least 2 inches from the shell.

(2) The gas holder may be located in the generator room, in a separate room or out of doors. In order to prevent collapse of the gas bell or infiltration of air due to a vacuum caused by the compressor or booster pump or cooling of the gas, a compressor or booster cutoff shall be provided at a point 12 inches or more above the landing point of the bell. When the gas holder is located indoors, the room shall be ventilated in accordance with subdivision (vi)(b) of this subparagraph and heated and lighted in accordance with subdivisions (vi)(c) and (d) of this subparagraph.

(3) When the gas holder is not located within a heated building, gas holder seals shall be protected against freezing.

(4) Means shall be provided to stop the generator-feeding mechanism

§ 1910.252

before the gas holder reaches the upper limit of its travel.

(5) When the gas holder is connected to only one generator, the gas capacity of the holder shall be not less than one-third of the hourly rating of the generator.

(6) If acetylene is used from the gas holder without increase in pressure at some points but with increase in pressure by a compressor or booster pump at other points, approved piping protective devices shall be installed in each supply line. The low-pressure protective device shall be located between the gas holder and the shop piping, and the medium-pressure protective device shall be located between the compressor or booster pump and the shop piping (see Figure Q-4). Approved protective equipment (designated P_F) is used to prevent: Backflow of oxygen into the fuel-gas supply system; passage of a flashback into the fuel-gas supply system; and excessive back pressure of oxygen in the fuel-gas supply system. The three functions of the protective equipment may be combined in one device or may be provided by separate devices.

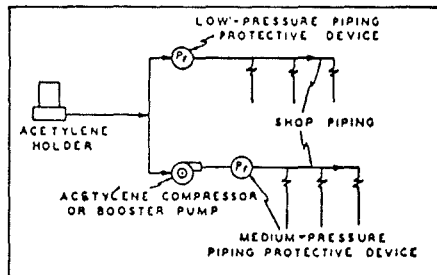

Figure Q-4

(d) (1) The compressor or booster system shall be of an approved type.

(2) Wiring and electrical equipment in compressor or booster pump rooms or enclosures shall conform to the provisions of § 1910.324 for Class I, Division 2 locations.

(3) Compressors and booster pump equipment shall be located in well-ventilated areas away from open flames, electrical or mechanical sparks, or other ignition sources.

29 CFR Ch. XVII (7-1-85 Edition)

(4) Compressor or booster pumps shall be provided with pressure relief valves which will relieve pressure exceeding 15 p.s.i.g. to a safe outdoor location as provided in subdivision (b) of this subdivision, or by returning the gas to the inlet side or to the gas supply source.

(5) Compressor or booster pump discharge outlets shall be provided with approved protective equipment. (See paragraph (a)(5) of this section.)

(v) *Portable acetylene generators.* (a)

(1) All portable generators shall be of a type approved for portable use.

(2) Portable generators shall not be used within 10 feet of combustible material other than the floor.

(3) Portable generators shall not be used in rooms of total volume less than 35 times the total gas-generating capacity per charge of all generators in the room. Generators shall not be used in rooms having a ceiling height of less than 10 feet. (To obtain the gas-generating capacity in cubic feet per charge, multiply the pounds of carbide per charge by 4.5.)

(4) Portable generators shall be protected against freezing. The use of salt or other corrosive chemical to prevent freezing is prohibited.

(b) (1) Portable generators shall be cleaned and recharged and the air mixture blown off outside buildings.

(2) When charged with carbide, portable generators shall not be moved by crane or derrick.

(3) When not in use, portable generators shall not be stored in rooms in which open flames are used unless the generators contain no carbide and have been thoroughly purged of acetylene. Storage rooms shall be well ventilated.

(4) When portable acetylene generators are to be transported and operated on vehicles, they shall be securely anchored to the vehicles. If transported by truck, the motor shall be turned off during charging, cleaning, and generating periods.

(5) Portable generators shall be located at a safe distance from the welding position so that they will not be exposed to sparks, slag, or misdirected

Occupational Safety and Health Admin., Labor

§ 1910.252

tion of the torch flame or overheating from hot materials or processes.

(vi) *Outside generator houses and inside generator rooms for stationary acetylene generators.* (a) (1) No opening in any outside generator house shall be located within 5 feet of any opening in another building.

(2) Walls, floors, and roofs of outside generator houses shall be of noncombustible construction.

(3) When a part of the generator house is to be used for the storage or manifolding of oxygen cylinders, the space to be so occupied shall be separated from the generator or carbide storage section by partition walls continuous from floor to roof or ceiling, of the type of construction stated in paragraph (a)(8) of this section. Such separation walls shall be without openings and shall be joined to the floor, other walls and ceiling or roof in a manner to effect a permanent gas-tight joint.

(4) Exit doors shall be located so as to be readily accessible in case of emergency.

(5) Explosion venting for outside generator houses and inside generator rooms shall be provided in exterior walls or roofs. The venting areas shall be equal to not less than 1 square foot per 50 cubic feet of room volume and may consist of any one or any combination of the following: Walls of light, noncombustible material preferably single-thickness, single-strength glass; lightly fastened hatch covers; lightly fastened swinging doors in exterior walls opening outward; lightly fastened walls or roof designed to relieve at a maximum pressure of 25 pounds per square foot.

(6) The installation of acetylene generators within buildings shall be restricted to buildings not exceeding one story in height; *Provided, however,* that this will not be construed as prohibiting such installations on the roof or top floor of a building exceeding such height.

(7) Generators installed inside buildings shall be enclosed in a separate room.

(8) The walls, partitions, floors, and ceilings of inside generator rooms shall be of noncombustible construction having a fire-resistance rating of

at least 1 hour. The walls or partitions shall be continuous from floor to ceiling and shall be securely anchored. At least one wall of the room shall be an exterior wall.

(9) Openings from an inside generator room to other parts of the building shall be protected by a swinging type, self-closing fire door for a Class B opening and having a rating of at least 1 hour. Windows in partitions shall be wired glass and approved metal frames with fixed sash. Installation shall be in accordance with the Standard for the Installation of Fire Doors and Windows, NFPA 80-1970.

(b) Inside generator rooms or outside generator houses shall be well ventilated with vents located at floor and ceiling levels.

(c) Heating shall be by steam, hot water, enclosed electrically heated elements or other indirect means. Heating by flames or fires shall be prohibited in outside generator houses or inside generator rooms, or in any enclosure communicating with them.

(d) (1) Generator houses or rooms shall have natural light during daylight hours. Where artificial lighting is necessary it shall be restricted to electric lamps installed in a fixed position. Unless specifically approved for use in atmospheres containing acetylene, such lamps shall be provided with enclosures of glass or other noncombustible material so designed and constructed as to prevent gas vapors from reaching the lamp or socket and to resist breakage. Rigid conduit with threaded connections shall be used.

(2) Lamps installed outside of wired-glass panels set in gas-tight frames in the exterior walls or roof of the generator house or room are acceptable.

(e) Electric switches, telephones, and all other electrical apparatus which may cause a spark, unless specifically approved for use inside acetylene generator rooms, shall be located outside the generator house or in a room or space separated from the generator room by a gas-tight partition, except that where the generator system is designed so that no carbide fill opening or other part of the generator is open to the generator house or room during the operation of the generator, and so that residue is carried in closed piping

§ 1910.252

29 CFR Ch. XVII (7-1-85 Edition)

from the residue discharge valve to a point outside the generator house or room, electrical equipment in the generator house or room shall conform to the provisions of Subpart S of this part for Class I, Division 2 locations.

(vii) *Maintenance and operation.* (a) Unauthorized persons shall not be permitted in outside generator houses or inside generator rooms.

(1) Operating instructions shall be posted in a conspicuous place near the generator or kept in a suitable place available for ready reference.

(2) When recharging generators the order of operations specified in the instructions supplied by the manufacturer shall be followed.

(3) In the case of batch-type generators, when the charge of carbide is exhausted and before additional carbide is added, the generating chamber shall always be flushed out with water, renewing the water supply in accordance with the instruction card furnished by the manufacturer.

(4) The water-carbide residue mixture drained from the generator shall not be discharged into sewer pipes or stored in areas near open flames. Clear water from residue settling pits may be discharged into sewer pipes.

(b) The carbide added each time the generator is recharged shall be sufficient to refill the space provided for carbide without ramming the charge. Steel or other ferrous tools shall not be used in distributing the charge.

(c) Generator water chambers shall be kept filled to proper level at all times except while draining during the recharging operation.

(d) Whenever repairs are to be made or the generator is to be charged or carbide is to be removed, the water chamber shall be filled to the proper level.

(e) Previous to making repairs involving welding, soldering, or other hot work or other operations which produce a source of ignition, the carbide charge and feed mechanism shall be completely removed. All acetylene shall be expelled by completely flooding the generator shell with water and the generator shall be disconnected from the piping system. The generator shall be kept filled with water, if possi-

ble, or positioned to hold as much water as possible.

(f) Hot repairs shall not be made in a room where there are other generators unless all the generators and piping have been purged of acetylene.

(7) *Calcium carbide storage*—(i) *Packaging.* (a) Calcium carbide shall be contained in metal packages of sufficient strength to prevent rupture. The packages shall be provided with a screw top or equivalent. These packages shall be constructed water- and air-tight. Solder shall not be used in such a manner that the package would fall if exposed to fire.

(b) Packages containing calcium carbide shall be conspicuously marked "Calcium Carbide—Dangerous If Not Kept Dry" or with equivalent warning.

(c) Caution: Metal tools, even the so-called spark resistant type may cause ignition of an acetylene and air mixture when opening carbide containers.

(d) Sprinkler systems shall not be installed in carbide storage rooms.

(ii) *Storage indoors.* (a) Calcium carbide in quantities not to exceed 600 pounds may be stored indoors in dry, waterproof, and well-ventilated locations.

(1) Calcium carbide not exceeding 600 pounds may be stored indoors in the same room with fuel-gas cylinders.

(2) Packages of calcium carbide, except for one of each size, shall be kept sealed. The seals shall not be broken when there is carbide in excess of 1 pound in any other unsealed package of the same size of carbide in the room.

(b) Calcium carbide exceeding 600 pounds but not exceeding 5,000 pounds shall be stored:

(1) In accordance with paragraph (a)(7)(ii)(c) of this section.

(2) In an inside generator room or outside generator house; or

(3) In a separate room in a one-story building which may contain other occupancies, but without cellar or basement beneath the carbide storage section. Such rooms shall be constructed in accordance with subdivision (vi) (a) (8) and (9) of this subdivision and ventilated in accordance with subdivision (vi)(b) of this subdivision. These rooms shall be used for no other purpose.

Occupational Safety and Health Admin., Labor

§ 1910.252

(c) Calcium carbide in excess of 5,000 pounds shall be stored in one-story buildings without cellar or basement and used for no other purpose, or in outside generator houses. If the storage building is of noncombustible construction, it may adjoin other one-story buildings if separated therefrom by unpierced firewalls; if it is detached less than 10 feet from such building or buildings, there shall be no opening in any of the mutually exposing sides of such buildings within 10 feet. If the storage building is of combustible construction, it shall be at least 20 feet from any other one- or two-story building, and at least 30 feet from any other building exceeding two stories.

(iii) *Storage outdoors.* (a) Calcium carbide in unopened metal containers may be stored outdoors.

(b) Carbide containers to be stored outdoors shall be examined to make sure that they are in good condition. Periodic reexaminations shall be made for rusting or other damage to a container that might affect its water or air tightness.

(c) The bottom tier of each row shall be placed on wooden planking or equivalent, so that the containers will not come in contact with the ground or ground water.

(d) [Reserved]

(e) Containers of carbide which have been in storage the longest shall be used first.

(b) *Application, installation, and operation of arc welding and cutting equipment*—(1) *General*—(i) *Equipment selection.* Welding equipment shall be chosen for safe application to the work to be done as specified in paragraph (b)(2) of this section.

(ii) *Installation.* Welding equipment shall be installed safely as specified by paragraph (b)(3) of this section.

(iii) *Instruction.* Workmen designated to operate arc welding equipment shall have been properly instructed and qualified to operate such equipment as specified in paragraph (b)(4) of this section.

(2) *Application of arc welding equipment*—(i) *General.* Assurance of consideration of safety in design is obtainable by choosing apparatus complying with the Requirements for Electric Arc-Welding Apparatus, NEMA EW-1-

1962, National Electrical Manufacturers Association or the Safety Standard for Transformer-Type Arc-Welding Machines, ANSI C33.2—1956, Underwriters' Laboratories.

(ii) *Environmental conditions.* (a) Standard machines for arc welding service shall be designed and constructed to carry their rated load with rated temperature rises where the temperature of the cooling air does not exceed 40° C. (104° F.) and where the altitude does not exceed 3,300 feet, and shall be suitable for operation in atmospheres containing gases, dust, and light rays produced by the welding arc.

(b) Unusual service conditions may exist, and in such circumstances machines shall be especially designed to safely meet the requirements of the service. Chief among these conditions are:

(1) Exposure to unusually corrosive fumes.

(2) Exposure to steam or excessive humidity.

(3) Exposure to excessive oil vapor.

(4) Exposure to flammable gases.

(5) Exposure to abnormal vibration or shock.

(6) Exposure to excessive dust.

(7) Exposure to weather.

(8) Exposure to unusual seacoast or shipboard conditions.

(iii) *Voltage.* The following limits shall not be exceeded:

(a) Alternating-current machines

(1) Manual arc welding and cutting—80 volts.

(2) Automatic (machine or mechanized) arc welding and cutting—100 volts.

(b) Direct-current machines

(1) Manual arc welding and cutting—100 volts.

(2) Automatic (machine or mechanized) arc welding and cutting—100 volts.

(c) When special welding and cutting processes require values of open circuit voltages higher than the above, means shall be provided to prevent the operator from making accidental contact with the high voltage by adequate insulation or other means.

(d) For a.c. welding under wet conditions or warm surroundings where perspiration is a factor, the use of reliable

§ 1910.252

29 CFR Ch. XVII (7-1-85 Edition)

automatic controls for reducing no load voltage is recommended to reduce the shock hazard.

(iv) *Design.* (a) A controller integrally mounted in an electric motor driven welder shall have capacity for carrying rated motor current, shall be capable of making and interrupting stalled rotor current of the motor, and may serve as the running overcurrent device if provided with the number of overcurrent units as specified by Subpart S of this part.

(b) On all types of arc welding machines, control apparatus shall be enclosed except for the operating wheels, levers, or handles.

(c) Input power terminals, tap change devices and live metal parts connected to input circuits shall be completely enclosed and accessible only by means of tools.

(d) Terminals for welding leads should be protected from accidental electrical contact by personnel or by metal objects i.e., vehicles, crane hooks, etc. Protection may be obtained by use of: Dead-front receptacles for plug connections; recessed openings with nonremovable hinged covers; heavy insulating sleeving or taping or other equivalent electrical and mechanical protection. If a welding lead terminal which is intended to be used exclusively for connection to the work is connected to the grounded enclosure, it must be done by a conductor at least two AWG sizes smaller than the grounding conductor and the terminal shall be marked to indicate that it is grounded.

(e) No connections for portable control devices such as push buttons to be carried by the operator shall be connected to an a.c. circuit of higher than 120 volts. Exposed metal parts of portable control devices operating on circuits above 50 volts shall be grounded by a grounding conductor in the control cable.

(f) Auto transformers or a.c. reactors shall not be used to draw welding current directly from any a.c. power source having a voltage exceeding 80 volts.

(3) *Installation of arc welding equipment*—(1) *General.* Installation including power supply shall be in accord-

ance with the requirements of Subpart S of this part.

(ii) *Grounding.* (a) The frame or case of the welding machine (except engine-driven machines shall be grounded under the conditions and according to the methods prescribed in Subpart S of this part.

(b) Conduits containing electrical conductors shall not be used for completing a work-lead circuit. Pipelines shall not be used as a permanent part of a work-lead circuit, but may be used during construction, extension or repair providing current is not carried through threaded joints, flanged bolted joints, or caulked joints and that special precautions are used to avoid sparking at connection of the work-lead cable.

(c) Chains, wire ropes, cranes, hoists, and elevators shall not be used to carry welding current.

(d) Where a structure, conveyor, or fixture is regularly employed as a welding current return circuit, joints shall be bonded or provided with adequate current collecting devices.

(e) All ground connections shall be checked to determine that they are mechanically strong and electrically adequate for the required current.

(iii) *Supply connections and conductors.* (a) A disconnecting switch or controller shall be provided at or near each welding machine which is not equipped with such a switch or controller mounted as an integral part of the machine. The switch shall be in accordance with Subpart S of this part. Overcurrent protection shall be provided as specified in Subpart S of this part. A disconnect switch with overload protection or equivalent disconnect and protection means, permitted by Subpart S of this part, shall be provided for each outlet intended for connection to a portable welding machine.

(b) For individual welding machines, the rated current-carrying capacity of the supply conductors shall be not less than the rated primary current of the welding machines.

(c) For groups of welding machines, the rated current-carrying capacity of conductors may be less than the sum of the rated primary currents of the welding machines supplied. The con-

Occupational Safety and Health Admin., Labor

§ 1910.252

ductor rating shall be determined in each case according to the machine loading based on the use to be made of each welding machine and the allowance permissible in the event that all the welding machines supplied by the conductors will not be in use at the same time.

(d) In operations involving several welders on one structure, d.c. welding process requirements may require the use of both polarities; or supply circuit limitations for a.c. welding may require distribution of machines among the phases of the supply circuit. In such cases no load voltages between electrode holders will be 2 times normal in d.c. or 1, 1.41, 1.73, or 2 times normal on a.c. machines. Similar voltage differences will exist if both a.c. and d.c. welding are done on the same structure.

(1) All d.c. machines shall be connected with the same polarity.

(2) All a.c. machines shall be connected to the same phase of the supply circuit and with the same instantaneous polarity.

(4) *Operation and maintenance*—(i) *General.* Workmen assigned to operate or maintain arc welding equipment shall be acquainted with the requirements of paragraphs (b), (d), (e), and (f) of this section; if doing gas-shielded arc welding, also Recommended Safe Practices for Gas-Shielded Arc Welding, A6.1-1966, American Welding Society.

(ii) *Machine hook up.* Before starting operations all connections to the machine shall be checked to make certain they are properly made. The work lead shall be firmly attached to the work; magnetic work clamps shall be freed from adherent metal particles of spatter on contact surfaces. Coiled welding cable shall be spread out before use to avoid serious overheating and damage to insulation.

(iii) *Grounding.* Grounding of the welding machine frame shall be checked. Special attention shall be given to safety ground connections of portable machines.

(iv) *Leaks.* There shall be no leaks of cooling water, shielding gas or engine fuel.

(v) *Switches.* It shall be determined that proper switching equipment for

shutting down the machine is provided.

(vi) *Manufacturers' instructions.* Printed rules and instructions covering operation of equipment supplied by the manufacturers shall be strictly followed.

(vii) *Electrode holders.* Electrode holders when not in use shall be so placed that they cannot make electrical contact with persons, conducting objects, fuel or compressed gas tanks.

(viii) *Electric shock.* Cables with splices within 10 feet of the holder shall not be used. The welder should not coil or loop welding electrode cable around parts of his body.

(ix) *Maintenance.* (a) The operator should report any equipment defect or safety hazard to his supervisor and the use of the equipment shall be discontinued until its safety has been assured. Repairs shall be made only by qualified personnel.

(b) Machines which have become wet shall be thoroughly dried and tested before being used.

(c) Cables with damaged insulation or exposed bare conductors shall be replaced. Joining lengths of work and electrode cables shall be done by the use of connecting means specifically intended for the purpose. The connecting means shall have insulation adequate for the service conditions.

(c) *Installation and operation of resistance welding equipment*—(1) *General*—(i) *Installation.* All equipment shall be installed by a qualified electrician in conformance with Subpart S of this part. There shall be a safety-type disconnecting switch or a circuit breaker or circuit interrupter to open each power circuit to the machine, conveniently located at or near the machine, so that the power can be shut off when the machine or its controls are to be serviced.

(ii) *Thermal protection.* Ignitron tubes used in resistance welding equipment shall be equipped with a thermal protection switch.

(iii) *Personnel.* Workmen designated to operate resistance welding equipment shall have been properly instructed and judged competent to operate such equipment.

(iv) *Guarding.* Controls of all automatic or air and hydraulic clamps

§ 1910.252

shall be arranged or guarded to prevent the operator from accidentally activating them.

(2) *Spot and seam welding machines (nonportable)*—(i) *Voltage*. All external weld initiating control circuits shall operate on low voltage, not over 120 volts, for the safety of the operators.

(ii) *Capacitor welding*. Stored energy or capacitor discharge type of resistance welding equipment and control panels involving high voltage (over 550 volts) shall be suitably insulated and protected by complete enclosures, all doors of which shall be provided with suitable interlocks and contacts wired into the control circuit (similar to elevator interlocks). Such interlocks or contacts shall be so designed as to effectively interrupt power and short circuit all capacitors when the door or panel is open. A manually operated switch or suitable positive device shall be installed, in addition to the mechanical interlocks or contacts, as an added safety measure assuring absolute discharge of all capacitors.

(iii) *Interlocks*. All doors and access panels of all resistance welding machines and control panels shall be kept locked and interlocked to prevent access, by unauthorized persons, to live portions of the equipment.

(iv) *Guarding*. All press welding machine operations, where there is a possibility of the operator's fingers being under the point of operation, shall be effectively guarded by the use of a device such as an electronic eye safety circuit, two hand controls or protection similar to that prescribed for punch press operation, § 1910.217. All chains, gears, operating bus linkage, and belts shall be protected by adequate guards, in accordance with § 1910.219.

(v) *Shields*. The hazard of flying sparks shall be, wherever practical, eliminated by installing a shield guard of safety glass or suitable fire-resistant plastic at the point of operation. Additional shields or curtains shall be installed as necessary to protect passing persons from flying sparks. (See paragraph (e) (2) (i) (c) of this section.)

29 CFR Ch. XVII (7-1-85 Edition)

(vi) *Foot switches*. All foot switches shall be guarded to prevent accidental operation of the machine.

(vii) *Stop buttons*. Two or more safety emergency stop buttons shall be provided on all special multispot welding machines, including 2-post and 4-post weld presses.

(viii) *Safety pins*. On large machines, four safety pins with plugs and receptacles (one in each corner) shall be provided so that when safety pins are removed and inserted in the ram or platen, the press becomes inoperative.

(ix) *Grounding*. Where technically practical, the secondary of all welding transformers used in multispot, projection and seam welding machines shall be grounded. This may be done by permanently grounding one side of the welding secondary current circuit. Where not technically practical, a center tapped grounding reactor connected across the secondary or the use of a safety disconnect switch in conjunction with the welding control are acceptable alternates. Safety disconnect shall be arranged to open both sides of the line when welding current is not present.

(3) *Portable welding machines*—(i) *Counterbalance*. All portable welding guns shall have suitable counterbalanced devices for supporting the guns, including cables, unless the design of the gun or fixture makes counterbalancing impractical or unnecessary.

(ii) *Safety chains*. All portable welding guns, transformers and related equipment that is suspended from overhead structures, eye beams, trolleys, etc. shall be equipped with safety chains or cables. Safety chains or cables shall be capable of supporting the total shock load in the event of failure of any component of the supporting system.

(iii) *Clevis*. Each clevis shall be capable of supporting the total shock load of the suspended equipment in the event of trolley failure.

(iv) *Switch guards*. All initiating switches, including retraction and dual schedule switches, located on the portable welding gun shall be equipped with suitable guards capable of preventing accidental initiation through contact with fixturing, operator's

Occupational Safety and Health Admin., Labor

§ 1910.252

clothing, etc. Initiating switch voltage shall not exceed 24 volts.

(v) *Moving holder.* The movable holder, where it enters the gun frame, shall have sufficient clearance to prevent the shearing of fingers carelessly placed on the operating movable holder.

(vi) *Grounding.* The secondary and case of all portable welding transformers shall be grounded. Secondary grounding may be by center tapped secondary or by a center tapped grounding reactor connected across the secondary.

(4) *Flash welding equipment—(i) Ventilation and flash guard.* Flash welding machines shall be equipped with a hood to control flying flash. In cases of high production, where materials may contain a film of oil and where toxic elements and metal fumes are given off, ventilation shall be provided in accordance with paragraph (f) of this section.

(ii) *Fire curtains.* For the protection of the operators of nearby equipment, fire-resistant curtains or suitable shields shall be set up around the machine and in such a manner that the operators movements are not hampered.

(5) [Reserved]

(6) *Maintenance.* Periodic inspection shall be made by qualified maintenance personnel, and records of the same maintained. The operator shall be instructed to report any equipment defects to his supervisor and the use of the equipment shall be discontinued until safety repairs have been completed.

(d) *Fire prevention and protection—*

(1) *Basic precautions.* For elaboration of these basic precautions and of the special precautions of paragraph (d)(2) of this section as well as a delineation of the fire protection and prevention responsibilities of welders and cutters, their supervisors (including outside contractors) and those in management on whose property cutting and welding is to be performed, see, Standard for Fire Prevention in Use of Cutting and Welding Processes, NFPA Standard 51B, 1962. The basic precautions for fire prevention in welding or cutting work are:

(i) *Fire hazards.* If the object to be welded or cut cannot readily be moved, all movable fire hazards in the vicinity shall be taken to a safe place.

(ii) *Guards.* If the object to be welded or cut cannot be moved and if all the fire hazards cannot be removed, then guards shall be used to confine the heat, sparks, and slag, and to protect the immovable fire hazards.

(iii) *Restrictions.* If the requirements stated in subdivision (i) and (ii) of this subdivision cannot be followed then welding and cutting shall not be performed.

(2) *Special precautions.* When the nature of the work to be performed falls within the scope of subdivision (ii) of this subdivision certain additional precautions may be necessary:

(i) *Combustible material.* Wherever there are floor openings or cracks in the flooring that cannot be closed, precautions shall be taken so that no readily combustible materials on the floor below will be exposed to sparks which might drop through the floor. The same precautions shall be observed with regard to cracks or holes in walls, open doorways and open or broken windows.

(ii) *Fire extinguishers.* Suitable fire extinguishing equipment shall be maintained in a state of readiness for instant use. Such equipment may consist of pails of water, buckets of sand, hose or portable extinguishers depending upon the nature and quantity of the combustible material exposed.

(iii) *Fire watch.* (a) Fire watchers shall be required whenever welding or cutting is performed in locations where other than a minor fire might develop, or any of the following conditions exist:

(1) Appreciable combustible material, in building construction or contents, closer than 35 feet to the point of operation.

(2) Appreciable combustibles are more than 35 feet away but are easily ignited by sparks.

(3) Wall or floor openings within a 35-foot radius expose combustible material in adjacent areas including concealed spaces in walls or floors.

(4) Combustible materials are adjacent to the opposite side of metal partitions, walls, ceilings, or roofs and are

§ 1910.252

29 CFR Ch. XVII (7-1-85 Edition)

likely to be ignited by conduction or radiation.

(b) Fire watchers shall have fire extinguishing equipment readily available and be trained in its use. They shall be familiar with facilities for sounding an alarm in the event of a fire. They shall watch for fires in all exposed areas, try to extinguish them only when obviously within the capacity of the equipment available, or otherwise sound the alarm. A fire watch shall be maintained for at least a half hour after completion of welding or cutting operations to detect and extinguish possible smoldering fires.

(iv) *Authorization.* Before cutting or welding is permitted, the area shall be inspected by the individual responsible for authorizing cutting and welding operations. He shall designate precautions to be followed in granting authorization to proceed preferably in the form of a written permit.

(v) *Floors.* Where combustible materials such as paper clippings, wood shavings, or textile fibers are on the floor, the floor shall be swept clean for a radius of 35 feet. Combustible floors shall be kept wet, covered with damp sand, or protected by fire-resistant shields. Where floors have been wet down, personnel operating arc welding or cutting equipment shall be protected from possible shock.

(vi) *Prohibited areas.* Cutting or welding shall not be permitted in the following situations:

(a) In areas not authorized by management.

(b) In sprinklered buildings while such protection is impaired.

(c) In the presence of explosive atmospheres (mixtures of flammable gases, vapors, liquids, or dusts with air), or explosive atmospheres that may develop inside uncleaned or improperly prepared tanks or equipment which have previously contained such materials, or that may develop in areas with an accumulation of combustible dusts.

(d) In areas near the storage of large quantities of exposed, readily ignitable materials such as bulk sulfur, baled paper, or cotton.

(vii) *Relocation of combustibles.* Where practicable, all combustibles shall be relocated at least 35 feet from

the work site. Where relocation is impracticable, combustibles shall be protected with flameproofed covers or otherwise shielded with metal or asbestos guards or curtains.

(viii) *Ducts.* Ducts and conveyor systems that might carry sparks to distant combustibles shall be suitably protected or shut down.

(ix) *Combustible walls.* Where cutting or welding is done near walls, partitions, ceiling or roof of combustible construction, fire-resistant shields or guards shall be provided to prevent ignition.

(x) *Noncombustible walls.* If welding is to be done on a metal wall, partition, ceiling or roof, precautions shall be taken to prevent ignition of combustibles on the other side, due to conduction or radiation, preferably by relocating combustibles. Where combustibles are not relocated, a fire watch on the opposite side from the work shall be provided.

(xi) *Combustible cover.* Welding shall not be attempted on a metal partition, wall, ceiling or roof having a combustible covering nor on walls or partitions of combustible sandwich-type panel construction.

(xii) *Pipes.* Cutting or welding on pipes or other metal in contact with combustible walls, partitions, ceilings or roofs shall not be undertaken if the work is close enough to cause ignition by conduction.

(xiii) *Management.* Management shall recognize its responsibility for the safe usage of cutting and welding equipment on its property and:

(a) Based on fire potentials of plant facilities, establish areas for cutting and welding, and establish procedures for cutting and welding, in other areas.

(b) Designate an individual responsible for authorizing cutting and welding operations in areas not specifically designed for such processes.

(c) Insist that cutters or welders and their supervisors are suitably trained in the safe operation of their equipment and the safe use of the process.

(d) Advise all contractors about flammable materials or hazardous conditions of which they may not be aware.

(xiv) *Supervisor.* The Supervisor:

Occupational Safety and Health Admin., Labor

§ 1910.252

(a) Shall be responsible for the safe handling of the cutting or welding equipment and the safe use of the cutting or welding process.

(b) Shall determine the combustible materials and hazardous areas present or likely to be present in the work location.

(c) Shall protect combustibles from ignition by the following:

(1) Have the work moved to a location free from dangerous combustibles.

(2) If the work cannot be moved, have the combustibles moved to a safe distance from the work or have the combustibles properly shielded against ignition.

(3) See that cutting and welding are so scheduled that plant operations that might expose combustibles to ignition are not started during cutting or welding.

(d) Shall secure authorization for the cutting or welding operations from the designated management representative.

(e) Shall determine that the cutter or welder secures his approval that conditions are safe before going ahead.

(f) Shall determine that fire protection and extinguishing equipment are properly located at the site.

(g) Where fire watches are required, he shall see that they are available at the site.

(xv) *Fire prevention precautions.* Cutting or welding shall be permitted only in areas that are or have been made fire safe. When work cannot be moved practically, as in most construction work, the area shall be made safe by removing combustibles or protecting combustibles from ignition sources.

(3) *Welding or cutting containers—*

(i) *Used containers.* No welding, cutting, or other hot work shall be performed on used drums, barrels, tanks or other containers until they have been cleaned so thoroughly as to make absolutely certain that there are no flammable materials present or any substances such as greases, tars, acids, or other materials which when subjected to heat, might produce flammable or toxic vapors. Any pipe lines or connections to the drum or vessel shall be disconnected or blanked.

(ii) *Venting and purging.* All hollow spaces, cavities or containers shall be vented to permit the escape of air or gases before preheating, cutting or welding. Purging with inert gas is recommended.

(4) *Confined spaces—*(i) *Accidental contact.* When arc welding is to be suspended for any substantial period of time, such as during lunch or overnight, all electrodes shall be removed from the holders and the holders carefully located so that accidental contact cannot occur and the machine be disconnected from the power source.

(ii) *Torch valve.* In order to eliminate the possibility of gas escaping through leaks or improperly closed valves, when gas welding or cutting, the torch valves shall be closed and the gas supply to the torch positively shutoff at some point outside the confined area whenever the torch is not to be used for a substantial period of time, such as during lunch hour or overnight. Where practicable, the torch and hose shall also be removed from the confined space.

(e) *Protection of personnel—*(1) *General—*(i) *Railing.* A welder or helper working on platforms, scaffolds, or runways shall be protected against falling. This may be accomplished by the use of railings, safety belts, life lines, or some other equally effective safeguards.

(ii) *Welding cable.* Welders shall place welding cable and other equipment so that it is clear of passageways, ladders, and stairways.

(2) *Eye protection—*(i) *Selection.* (a) Helmets or hand shields shall be used during all arc welding or arc cutting operations, excluding submerged arc welding. Helpers or attendants shall be provided with proper eye protection.

(b) Goggles or other suitable eye protection shall be used during all gas welding or oxygen cutting operations. Spectacles without side shields, with suitable filter lenses are permitted for use during gas welding operations on light work, for torch brazing or for inspection.

(c) All operators and attendants of resistance welding or resistance brazing equipment shall use transparent face shields or goggles, depending on

§ 1910.252

the particular job, to protect their faces or eyes, as required.

(d) Eye protection in the form of suitable goggles shall be provided where needed for brazing operations not covered in (a), (b), and (c) of this subdivision.

(ii) *Specifications for protectors.* (a) Helmets and hand shields shall be made of a material which is an insulator for heat and electricity. Helmets, shields and goggles shall be not readily flammable and shall be capable of withstanding sterilization.

(b) Helmets and hand shields shall be arranged to protect the face, neck and ears from direct radiant energy from the arc.

(c) Helmets shall be provided with filter plates and cover plates designed for easy removal.

(d) All parts shall be constructed of a material which will not readily corrode or discolor the skin.

(e) Goggles shall be ventilated to prevent fogging of the lenses as much as practicable.

(f) [Reserved]

(g) All glass for lenses shall be tempered, substantially free from striae, air bubbles, waves and other flaws. Except when a lens is ground to provide proper optical correction for defective vision, the front and rear surfaces of lenses and windows shall be smooth and parallel.

(h) Lenses shall bear some permanent distinctive marking by which the source and shade may be readily identified.

(i) The following is a guide for the selection of the proper shade numbers. These recommendations may be varied to suit the individual's needs.

Welding operation	Shade No.
Shielded metal-arc welding— $\frac{1}{16}$ -, $\frac{3}{32}$ -, $\frac{1}{8}$ -, $\frac{5}{32}$ -inch electrodes.....	10
Gas-shielded arc welding (nonferrous)— $\frac{1}{16}$ -, $\frac{3}{32}$ -, $\frac{1}{8}$ -, $\frac{5}{32}$ -inch electrodes.....	11
Gas-shielded arc welding (ferrous)— $\frac{1}{16}$ -, $\frac{3}{32}$ -, $\frac{1}{8}$ -, $\frac{5}{32}$ -inch electrodes.....	12
Shielded metal-arc welding: $\frac{1}{16}$ -, $\frac{3}{32}$ -, $\frac{1}{8}$ -inch electrodes.....	12
$\frac{1}{16}$ -, $\frac{3}{32}$ -inch electrodes.....	14
Atomic hydrogen welding.....	10-14
Carbon arc welding.....	14
Soldering.....	2
Torch brazing.....	3 or 4
Light cutting, up to 1 inch.....	3 or 4
Medium cutting, 1 inch to 6 inches.....	4 or 5

29 CFR Ch. XVII (7-1-85 Edition)

Welding operation	Shade No.
Heavy cutting, 6 inches and over.....	5 or 6
Gas welding (light) up to $\frac{1}{8}$ inch.....	4 or 5
Gas welding (medium) $\frac{1}{8}$ inch to $\frac{1}{4}$ inch.....	5 or 6
Gas welding (heavy) $\frac{1}{4}$ inch and over.....	6 or 8

NOTE: In gas welding or oxygen cutting where the torch produces a high yellow light, it is desirable to use a filter or lens that absorbs the yellow or sodium line in the visible light of the operation.

(j) All filter lenses and plates shall meet the test for transmission of radiant energy prescribed in ANSI Z87.1-1968—American National Standard Practice for Occupational and Educational Eye and Face Protection.

(iii) *Protection from arc welding rays.* Where the work permits, the welder should be enclosed in an individual booth painted with a finish of low reflectivity such as zinc oxide (an important factor for absorbing ultraviolet radiations) and lamp black, or shall be enclosed with noncombustible screens similarly painted. Booths and screens shall permit circulation of air at floor level. Workers or other persons adjacent to the welding areas shall be protected from the rays by noncombustible or flameproof screens or shields or shall be required to wear appropriate goggles.

(3) *Protective clothing*—(i) *General requirements.* Employees exposed to the hazards created by welding, cutting, or brazing operations shall be protected by personal protective equipment in accordance with the requirements of § 1910.132. Appropriate protective clothing required for any welding operation will vary with the size, nature and location of the work to be performed.

(4) *Work in confined spaces*—(i) *General.* As used herein confined space is intended to mean a relatively small or restricted space such as a tank, boiler, pressure vessel, or small compartment of a ship.

(ii) *Ventilation.* Ventilation is a prerequisite to work in confined spaces. For ventilation requirements see paragraph (f) of this section.

(iii) *Securing cylinders and machinery.* When welding or cutting is being performed in any confined spaces the gas cylinders and welding machines shall be left on the outside. Before operations are started, heavy portable

equipment mounted on wheels shall be securely blocked to prevent accidental movement

(iv) *Lifelines*. Where a welder must enter a confined space through a manhole or other small opening, means shall be provided for quickly removing him in case of emergency. When safety belts and lifelines are used for this purpose they shall be so attached to the welder's body that his body cannot be jammed in a small exit opening. An attendant with a pre-planned rescue procedure shall be stationed outside to observe the welder at all times and be capable of putting rescue operations into effect.

(v) *Electrode removal*. When arc welding is to be suspended for any substantial period of time, such as during lunch or overnight, all electrodes shall be removed from the holders and the holders carefully located so that accidental contact cannot occur and the machine disconnected from the power source.

(vi) *Gas cylinder shutoff*. In order to to eliminate the possibility of gas escaping through leaks of improperly closed valves, when gas welding or cutting, the torch valves shall be closed and the fuel-gas and oxygen supply to the torch positively shut off at some point outside the confined area whenever the torch is not to be used for a substantial period of time, such as during lunch hour or overnight. Where practicable the torch and hose shall also be removed from the confined space.

(vii) *Warning sign*. After welding operations are completed, the welder shall mark the hot metal or provide some other means of warning other workers.

(f) *Health protection and ventilation*—(1) *General*—(1) *Contamination*. The requirements in this paragraph have been established on the basis of the following three factors in arc and gas welding which govern the amount of contamination to which welders may be exposed:

(a) Dimensions of space in which welding is to be done (with special regard to height of ceiling).

(b) Number of welders.

(c) Possible evolution of hazardous fumes, gases, or dust according to the metals involved.

(ii) [Reserved]

(iii) *Screens*. When welding must be performed in a space entirely screened on all sides, the screens shall be so arranged that no serious restriction of ventilation exists. It is desirable to have the screens so mounted that they are about 2 feet above the floor unless the work is performed at so low a level that the screen must be extended nearer to the floor to protect nearby workers from the glare of welding.

(iv) *Maximum allowable concentration*. Local exhaust or general ventilating systems shall be provided and arranged to keep the amount of toxic fumes, gases, or dusts below the maximum allowable concentration as specified in § 1910.1000.

(v) *Precautionary labels*. A number of potentially hazardous materials are employed in fluxes, coatings, coverings, and filler metals used in welding and cutting or are released to the atmosphere during welding and cutting. These include but are not limited to the materials itemized in paragraphs (f) (5) through (12) of this section. The suppliers of welding materials shall determine the hazard, if any, associated with the use of their materials in welding, cutting, etc.

(a) All filler metals and fusible granular materials shall carry the following notice, as a minimum, on tags, boxes, or other containers:

CAUTION

Welding may produce fumes and gases hazardous to health. Avoid breathing these fumes and gases. Use adequate ventilation. See ANSI Z49.1-1967 Safety in Welding and Cutting published by the American Welding Society.

(b) *Brazing* (welding) filler metals containing cadmium in significant amounts shall carry the following notice on tags, boxes, or other containers:

WARNING

CONTAINS CADMIUM—POISONOUS FUMES MAY BE FORMED ON HEATING

Do not breathe fumes. Use only with adequate ventilation such as fume collectors,

§ 1910.252

29 CFR Ch. XVII (7-1-85 Edition)

exhaust ventilators, or air-supplied respirators. See ANSI Z49.1-1967.

If chest pain, cough, or fever develops after use call physician immediately.

(c) Brazing and gas welding fluxes containing fluorine compounds shall have a cautionary wording to indicate that they contain fluorine compounds. One such cautionary wording recommended by the American Welding Society for brazing and gas welding fluxes reads as follows:

CAUTION

CONTAINS FLUORIDES

This flux when heated gives off fumes that may irritate eyes, nose and throat.

1. Avoid fumes—use only in well-ventilated spaces.
2. Avoid contact of flux with eyes or skin.
3. Do not take internally.

(2) *Ventilation for general welding and cutting*—(i) *General*. Mechanical ventilation shall be provided when welding or cutting is done on metals not covered in paragraphs (f) (5) through (12) of this section. (For specific materials, see the ventilation requirements of paragraphs (f) (5) through (12) of this section.)

(a) In a space of less than 10,000 cubic feet per welder.

(b) In a room having a ceiling height of less than 16 feet.

(c) In confined spaces or where the welding space contains partitions, balconies, or other structural barriers to the extent that they significantly obstruct cross ventilation.

(ii) *Minimum rate*. Such ventilation shall be at the minimum rate of 2,000 cubic feet per minute per welder, except where local exhaust hoods and booths as per paragraph (f)(3) of this section, or airline respirators approved by the U.S. Bureau of Mines for such purposes are provided. Natural ventilation is considered sufficient for welding or cutting operations where the restrictions in paragraph (f)(2)(i) of this section are not present.

(3) *Local exhaust hoods and booths*. Mechanical local exhaust ventilation may be by means of either of the following:

(i) *Hoods*. Freely movable hoods intended to be placed by the welder as near as practicable to the work being welded and provided with a rate of air-

flow sufficient to maintain a velocity in the direction of the hood of 100 linear feet per minute in the zone of welding when the hood is at its most remote distance from the point of welding. The rates of ventilation required to accomplish this control velocity using a 3-inch wide flanged suction opening are shown in the following table:

Welding zone	Minimum air flow ¹ cubic feet/ minutes	Duct diameter, inches ²
4 to 6 inches from arc or torch.....	150	3
6 to 8 inches from arc or torch.....	275	3½
8 to 10 inches from arc or torch.....	425	4½
10 to 12 inches from arc or torch....	800	5½

¹ When brazing with cadmium bearing materials or when cutting on such materials increased rates of ventilation may be required.

² Nearest half-inch duct diameter based on 4,000 feet per minute velocity in pipe.

(ii) *Fixed enclosure*. A fixed enclosure with a top and not less than two sides which surround the welding or cutting operations and with a rate of airflow sufficient to maintain a velocity away from the welder of not less than 100 linear feet per minute.

(4) *Ventilation in confined spaces*—

(i) *Air replacement*. All welding and cutting operations carried on in confined spaces shall be adequately ventilated to prevent the accumulation of toxic materials or possible oxygen deficiency. This applies not only to the welder but also to helpers and other personnel in the immediate vicinity. All air replacing that withdrawn shall be clean and respirable.

(ii) *Airline respirators*. In such circumstances where it is impossible to provide such ventilation, airline respirators or hose masks approved by the U.S. Bureau of Mines for this purpose shall be used.

(iii) *Self-contained units*. In areas immediately hazardous to life, hose masks with blowers or self-contained breathing equipment shall be used. The breathing equipment shall be approved by the U.S. Bureau of Mines.

(iv) *Outside helper*. Where welding operations are carried on in confined spaces and where welders and helpers are provided with hose masks, hose masks with blowers or self-contained

Occupational Safety and Health Admin., Labor

§ 1910.252

breathing equipment approved by the U.S. Bureau of Mines, a worker shall be stationed on the outside of such confined spaces to insure the safety of those working within.

(v) *Oxygen for ventilation.* Oxygen shall never be used for ventilation.

(5) *Fluorine compounds*—(i) *General.* In confined spaces, welding or cutting involving fluxes, coverings, or other materials which contain fluorine compounds shall be done in accordance with paragraph (f)(4) of this section. A fluorine compound is one that contains fluorine, as an element in chemical combination, not as a free gas.

(ii) *Maximum allowable concentration.* The need for local exhaust ventilation or airline respirators for welding or cutting in other than confined spaces will depend upon the individual circumstances. However, experience has shown such protection to be desirable for fixed-location production welding and for all production welding on stainless steels. Where air samples taken at the welding location indicate that the fluorides liberated are below the maximum allowable concentration, such protection is not necessary.

(6) *Zinc*—(i) *Confined spaces.* In confined spaces welding or cutting involving zinc-bearing base or filler metals or metals coated with zinc-bearing materials shall be done in accordance with paragraph (f)(4) of this section.

(ii) *Indoors.* Indoors, welding or cutting involving zinc-bearing base or filler metals coated with zinc-bearing materials shall be done in accordance with paragraph (f)(3) of this section.

(7) *Lead*—(i) *Confined spaces.* In confined spaces, welding involving lead-base metals (erroneously called lead-burning) shall be done in accordance with paragraph (f)(4) of this section.

(ii) *Indoors.* Indoors, welding involving lead-base metals shall be done in accordance with subparagraph (3) of this paragraph.

(iii) *Local ventilation.* In confined spaces or indoors, welding or cutting involving metals containing lead, other than as an impurity, or involving metals coated with lead-bearing materials, including paint shall be done using local exhaust ventilation or air-

line respirators. Outdoors such operations shall be done using respiratory protective equipment approved by the U.S. Bureau of Mines for such purposes. In all cases, workers in the immediate vicinity of the cutting operation shall be protected as necessary by local exhaust ventilation or airline respirators.

(8) *Beryllium.* Welding or cutting indoors, outdoors, or in confined spaces involving beryllium-containing base or filler metals shall be done using local exhaust ventilation and airline respirators unless atmospheric tests under the most adverse conditions have established that the workers' exposure is within the acceptable concentrations defined by § 1910.1000. In all cases, workers in the immediate vicinity of the welding or cutting operations shall be protected as necessary by local exhaust ventilation or airline respirators.

(9) *Cadmium*—(i) *General.* Welding or cutting indoors or in confined spaces involving cadmium-bearing or cadmium-coated base metals shall be done using local exhaust ventilation or airline respirators unless atmospheric tests under the most adverse conditions have established that the workers' exposure is within the acceptable concentrations defined by § 1910.1000. Outdoors such operations shall be done using respiratory protective equipment such as fume respirators approved by the U.S. Bureau of Mines for such purposes.

(ii) *Confined space.* Welding (brazing) involving cadmium-bearing filler metals shall be done using ventilation as prescribed in paragraph (f) (3) or (4) of this section if the work is to be done in a confined space.

(10) *Mercury.* Welding or cutting indoors or in a confined space involving metals coated with mercury-bearing materials including paint, shall be done using local exhaust ventilation or airline respirators unless atmospheric tests under the most adverse conditions have established that the workers' exposure is within the acceptable concentrations defined by § 1910.1000. Outdoors such operations shall be done using respiratory protective equipment approved by the U.S. Bureau of Mines for such purposes.

§ 1910.253

29 CFR Ch. XVII (7-1-85 Edition)

(11) *Cleaning compounds*—(i) *Manufacturer's instructions*. In the use of cleaning materials, because of their possible toxicity or flammability, appropriate precautions such as manufacturers instructions shall be followed.

(ii) *Degreasing*. Degreasing and other cleaning operations involving chlorinated hydrocarbons shall be so located that no vapors from these operations will reach or be drawn into the atmosphere surrounding any welding operation. In addition, trichloroethylene and perchlorethylene should be kept out of atmospheres penetrated by the ultraviolet radiation of gas-shielded welding operations.

(12) *Cutting of stainless steels*. Oxygen cutting, using either a chemical flux or iron powder or gas-shielded arc cutting of stainless steel, shall be done using mechanical ventilation adequate to remove the fumes generated.

(13) *First-aid equipment*. First-aid equipment shall be available at all times. All injuries shall be reported as soon as possible for medical attention. First aid shall be rendered until medical attention can be provided.

(g) *Industrial applications*—(1) *Transmission pipeline*—(i) *General*. The requirements of paragraphs (b), (e), and (f) of this section shall be observed.

(ii) *Field shop operations*. Where field shop operations are involved for fabrication of fittings, river crossings, road crossings, and pumping and compressor stations the requirements of paragraphs (a), (b), (d), (e), and (f) of this section shall be observed.

(iii) *Electric shock*. When arc welding is performed in wet conditions, or under conditions of high humidity, special protection against electric shock shall be supplied.

(iv) *Pressure testing*. In pressure testing of pipelines, the workers and the public shall be protected against injury by the blowing out of closures or other pressure restraining devices. Also, protection shall be provided against expulsion of loose dirt that may have become trapped in the pipe.

(v) *Construction standards*. The welded construction of transmission pipelines shall be conducted in accordance with the Standard for Welding

Pipe Lines and Related Facilities, API Std. 1104-1968.

(vi) *Flammable substance lines*. The connection, by welding, of branches to pipelines carrying flammable substances shall be performed in accordance with Welding or Hot Tapping on Equipment Containing Flammables, API Std. PSD No. 2201-1963.

(vii) *X-ray inspection*. The use of X-rays and radioactive isotopes for the inspection of welded pipeline joints shall be carried out in conformance with the American National Standard Safety Standard for Non-Medical X-ray and Sealed Gamma-Ray Sources, ANSI Z54.1-1963.

(2) *Mechanical piping systems*—(i) *General*. The requirements of paragraphs (a), (b), (d), (e), and (f) of this section shall be observed.

(ii) *X-ray inspection*. The use of X-rays and radioactive isotopes for the inspection of welded piping joints shall be in conformance with the American National Standard Safety Standard for Non-Medical X-ray and Sealed Gamma-Ray Sources, ANSI Z54.1-1963.

(The information collection requirements contained in paragraph (c)(6) were approved by the Office of Management and Budget under control number 1218-0056)

(Secs. 4(b)(2), 6(b) and 8(c), 84 Stat. 1592, 1593, 1596, 29 U.S.C. 653, 655, 657; Secretary of Labor's Order No. 8-76 (41 FR 25059); 29 CFR Part 1911; secs. 6, 8, 84 Stat. 1593, 1600 (29 U.S.C. 655, 657), Secretary of Labor's Order No. 9-83 (48 FR 35736), 29 CFR Part 1911)

[39 FR 23502, June 27, 1974, as amended at 40 FR 23073, May 28, 1975; 43 FR 49750, Oct. 24, 1978; 47 FR 14706, Apr. 6, 1982; 49 FR 5323, Feb. 10, 1984]

§ 1910.253 Sources of standards.

Sec.	Source
1910.251.....	ANSI Z49.1-1967, Safety in Welding and Cutting.
1910.252.....	(a) NFPA-51-1969, Welding and Cutting Oxygen Fuel Gas Systems.
	(b) ANSI Z-49.1 1967, Safety in Welding and Cutting.
	(c) NFPA 51B 1962, Cutting and Welding Processes.
	(d) 41 CFR 50-204.7.

Occupational Safety and Health Admin., Labor

§ 1910.261

§ 1910.254 Standards organizations.

Specific standards of the following organizations have been referenced in this subpart. Copies of the referenced standards may be obtained from the issuing organizations. The names and addresses of the issuing organizations are as follows:

- (a) American National Standards Institute (ANSI), 1430 Broadway, New York, NY 10018.
 - (b) National Fire Protection Association, 470 Atlantic Avenue, Boston, Massachusetts 02210.
 - (c) Compressed Gas Association, Inc., 500 Fifth Avenue, New York, NY 10036.
 - (d) American Petroleum Institute, 1801 K Street NW., Washington, DC 20006.
 - (e) American Welding Society, 345 East 47th Street, New York, NY 10017.
 - (f) Rubber Manufacturers Association, 444 Madison Avenue, New York, NY 10022.
- [39 FR 23502, June 27, 1974, as amended at 40 FR 18426, Apr. 28, 1975]

Subpart R—Special Industries

§ 1910.261 Pulp, paper, and paperboard mills.

(a) *General requirements*—(1) *Application*. This section applies to establishments where pulp, paper, and paperboard are manufactured and converted. This section does not apply to logging and the transportation of logs to pulp, paper, and paperboard mills.

(2) *Standards incorporated by reference*. Standards covering issues of occupational safety and health which have general application without regard to any specific industry are incorporated by reference in paragraphs (b) through (m) of this section and in subparagraphs (3) and (4) of this paragraph and made applicable under this section. Such standards shall be construed according to the rules set forth in § 1910.5.

(3) *General incorporation of standards*. Establishments subject to this section shall comply with the following standards of the American National Standards Institute:

- (i) Practice for Industrial Lighting, A11.1—1965 (R-1970).
- (ii) Safety Requirements for Floor and Wall Openings, Railings, and Toe Boards, A12.1—1967.

(iii) Scheme for the Identification of Piping Systems, A13.1—1956.

(iv) Safety Code for Portable Wood Ladders, A14.1—1968.

(v) Safety Code for Portable Metal Ladders A14.2—1956.

(vi) Safety Code for Fixed Ladders, A14.3—1956.

(vii) Safety Code for Elevators, Dumbwaiters, and Moving Walks, A17.1—1965, including Supplements A17.1a—1967, A17.1b—1968, A17.1c—1969, and A17.1d—1970.

(viii) Practice for the Inspection of Elevators (Inspector's Manual), A17.2—1960, including Supplements A17.2a—1965 and A17.2b—1967.

(ix) Safety Code for Mechanical Power-Transmission Apparatus, B15.1—1953 (Reaffirmed 1958).

(x) Safety Code for Conveyors, Cableways, and Related Equipment, B20.1—1957.

(xi) Safety Code for Cranes, Derricks, and Hoists, B30.2—1943 (Reaffirmed 1952 and partially revised by B30.2.0—1967 and B30.5—1968).

(xii) Overhead and Gantry Cranes, B30.2.0—1967 (Partial Revision of B30.2—1943).

(xiii) Crawler, Locomotive, and Truck Cranes, B30.5—1968 (Partial Revision of B30.2—1943).

(xiv) Power Piping, B31.1.0—1967 and addenda B31.10a—1969. Fuel Gas Piping, B31.2—1968.

(xv) Safety Code for Powered Industrial Trucks, B56.1—1969.

(xvi) Identification of Gas-Mask Canisters, K13.1—1967.

(xvii) Safety Code for Woodworking Machinery, O1.1—1954 (Reaffirmed 1961).

(xviii) Requirements for Sanitation in Places of Employment, Z4.1—1968.

(xix) Safety Code for Ventilation and Operation of Open-Surface Tanks, Z9.1—1951.

(xx) Fundamentals Governing the Design and Operation of Local Exhaust Systems, Z9.2—1960.

(xxi) Prevention of Sulfur Fires and Explosions, Z12.12—1968.

(xxii) Method of Measurement of Real-Ear Attenuation of Ear Protectors at Threshold, Z24.22—1957.

(xxiii) Installation of Blower and Exhaust Systems for Dust, Stock, and

A14.176 PROJECTION BOOTHS. The following is a reprint of ss. ILHR 55.40 to 55.49:

ILHR 55.40 Motion picture machine booths, general. Every motion picture machine using nitro-cellulose film, together with all auxiliary and associated equipment, shall be enclosed in a booth so arranged as to permit the operator to walk freely on either side and in back of the machine. At least 48 square feet in area shall be provided for one machine, and 24 square feet additional for each machine over one. The ceiling height shall be not less than 7 feet.

ILHR 55.41 Construction of booth. The floor of each motion picture booth shall be constructed of masonry or reinforced concrete, or shall be covered with not less than 2 inches of fire-resistive material. The walls and ceilings shall be not less than 2-hour fire-resistive construction as specified in s. ILHR 51.04.

History: 1-2-56; am. Register, February, 1971, No. 182, eff. 7-1-71; r. and recr. eff. 8-1-71 and exp. 1-1-72; cr. eff. 1-1-72, Register, July, 1971, No. 187.

ILHR 55.42 Doors. (1) The door to the booth shall be not larger than necessary for the safe and proper use and maintenance of the booth and equipment, but in no case shall its dimensions be smaller than 2 feet by 5 feet or larger than 3 feet by 7 feet. The top of the door shall be not less than 12 inches below the ceiling of the booth.

(2) The door shall be a tight-fitting self-closing fire door as specified in s. ILHR 51.047, shall open outwardly, and shall not be equipped with any latch.

History: 1-2-56; am. (2), Register, February, 1971, No. 182, eff. 7-1-71; r. and recr. (2) eff. 8-1-71 and exp. 1-1-72; cr. (2) eff. 1-1-72, Register, July, 1971, No. 187.

ILHR 55.43 Openings. (1) Two openings for each motion picture machine may be provided. The one for the operator's view shall not be larger than 200 square inches and the one for projection not larger than 120 square inches. Where separate stereopticon, spot, or floodlight machines are installed, not more than one opening shall be provided for each such machine for both the operator's view and the projection of light. All such openings shall be as small as practicable. **FP**

(2) Each opening shall be provided with an approved gravity shutter set into guides not less than one inch at sides and bottom, and overlapping the top of the opening by at least one inch when closed. Shutters shall be not less than No. 10 U.S. Standard gauge iron or equivalent, arranged to move freely in guides of like material and thickness bolted to

Register, August, 1985, No. 356

55.43

216 WISCONSIN ADMINISTRATIVE CODE

ILHR 55

Theaters, assembly halls

the wall. Each shutter shall be suspended by a cord and shall be so arranged that closing is by gravity action. A fusible link shall be provided in the cord over each shutter. A link shall also be provided over each magazine, which on operating will close all shutters. A manual release shall be provided near each exit door by which all shutters can be closed simultaneously. Shutters shall not be blocked open nor held open in any manner except by the harness of cords and links as herein described.

ILHR 55.44 Ventilation of booths. Every booth or room housing projection, sound or any other equipment which vitiates good air conditions or requires the attention of an attendant shall be ventilated as required by s. ILHR 64.05. Fresh air intakes in booth walls, except for outside air, shall not exceed 72 square inches in area, nor be more than 3 inches above the floor. They shall be equipped with automatic shutters as described for projection openings.

History: 1-2-56; r. and recr. Register, October, 1967, No. 142, eff. 11-1-67; am. Register, December, 1975, No. 240, eff. 1-1-76.

FP ILHR 55.45 Relief outlets. Every booth or room housing projection, sound or other equipment which constitutes a fire, smoke, explosion or fuming hazard shall be equipped with one or more gravity outlets extending upward from the ceiling through the roof. The net area of such gravity relief outlets shall be equal to one per cent of the room or booth floor area, but not less than 12 inches in diameter. Such outlets shall be constructed as sheet metal ducts having double walls with ¼ inch air space between, or better construction. Where a relief outlet passes through, or is within 18 inches of any combustible construction, or passes through any other occupancy, approved masonry flues as specified for chimneys, s. ILHR 64.46, shall be used. The relief outlets shall be equipped, at the booth or room outlets, with a gravity shutter which will open automatically under excessive heat conditions. The automatic shutter shall normally be tightly closed where mechanical exhaust ventilation is required in the same room.

FP ILHR 55.46 Electric wiring. All lights and electric wiring, also motors, arc lamps, rheostats, and associated electrical equipment shall conform in type and arrangement to the requirements of the Wisconsin state electrical code, vol. 2, ch. ILHR 16.

ILHR 55.47 Motion picture machine. Every projection machine shall be securely fastened to the floor, and together with sound head and other associated equipment, shall be of safe design. No part of the film shall be outside of a tight metal enclosure during projection, and the feed and take-up reels shall have riveted, flanged, or welded joints. A shutter shall be placed in front of the condenser, arranged so as to be closed except when held open by the operator, or by some mechanical device which will assure immediate closure when operation of the machine is stopped.

ILHR 55.48 Fire protection in booth; care and use of film. (1) All shelves, furniture and fixtures shall be incombustible. No combustible material shall be permitted to be within such booth, except films and film cement not exceeding one pint. Smoking is prohibited. Heating equipment in booths shall be limited to steam, warm air, hot water or electric convection heaters with low surface temperature elements. Radiators shall be protected by ¼ inch mesh screen with the top sloped at least 45° to the horizontal.

Register, August, 1985, No. 356

55.50

DEPT. OF INDUSTRY, LABOR & HUMAN RELATIONS 217
Theaters, assembly halls ILHR 55

(2) Films not in process of rewinding, examination or projection shall be kept in metal containers. Up to 40 pounds of film may be kept in the projection booth in interstate commerce commission shipping containers. Excess over 40 pounds shall be kept in an approved film cabinet, but the total quantity of film in any booth shall not exceed 125 pounds.

(3) Rewinding in the projection booth is prohibited unless done in an approved enclosed type rewind machine. An approved can with self-closing hinged cover shall be provided for scrap film.

(4) Up to 125 pounds of film in addition to that permitted in a projection booth, may be kept in containers as specified above, providing this excess is in a rewind room of not less than 80 square feet area, and of the construction specified in ss. ILHR 55.41 and 55.42. Such room shall have a vent of at least 50 square inches in area extending upward to the outside of the building, with a clearance to combustible material conforming to s. ILHR 55.45. Furniture and heating shall be as for the projection booth, and smoking is prohibited.

Note: The weight of a 1000 foot roll of 35 millimeter film is assumed as 5 pounds.

ILHR 55.49 Portable booths. (1) Every portable booth used to confine the fire hazards of a motion picture machine shall be of approved design conforming to the requirements for permanent booths.

(2) Every booth used for more than 3 consecutive performances in one location will be considered a permanent booth.

EFFECTIVE DATE

Pursuant to s. 227.22 (2) (intro), Stats., these rules shall take effect on the first day of the month following publication in the Wisconsin Administrative Register.

00051