

Chapters Comm 50-64

APPENDIX A

The material contained in the appendix is for clarification purposes only. The notes, illustrations, etc. are numbered to correspond to the number of the rule as it appears in the text of the code.

Comm A-50.06 (3) ISSUANCE OF BUILDING PERMITS. Section Comm 50.06 (3) refers to s. Comm 83.25 (2), which reads as follows:

Comm 83.25 (2) ISSUANCE OF BUILDING PERMITS. (a) *General.* Pursuant to s. 66.036, Stats., the issuance of building permits by a municipality for unsewered properties shall be in accordance with this subsection.

(b) *New construction.* A municipality may not issue a building permit to commence construction or installation of a structure that necessitates the use of a POWTS to serve the structure, unless:

1. The owner of the property possesses a sanitary permit for the installation of a POWTS in accordance with s. Comm 83.21; or

Note: Section Comm 83.21 outlines the procedures for the issuance of sanitary permits. Sections 145.135 and 145.19, Stats., mandate that no private sewage system may be installed unless the owner of the property holds a valid sanitary permit.

2. A POWTS of adequate capability and capacity to accommodate the wastewater flow and contaminant load already exists to serve the structure.

Note: See ss. Comm 83.02 and 83.03 concerning the application of current code requirements to existing POWTS.

(c) *Construction affecting wastewater flow or contaminant load.*

1. A municipality may not issue a building permit to commence construction of any addition or alteration to an existing structure when the proposed construction will modify the design wastewater flow or contaminant load, or both, to an existing POWTS, unless the owner of the property:

a. Possesses a sanitary permit to either modify the existing POWTS or construct a POWTS to accommodate the modification in wastewater flow or contaminant load, or both; or

b. Provides documentation to verify that the existing POWTS is sufficient to accommodate the modification in wastewater flow or contaminant load, or both.

2. For the purpose of this paragraph, a modification in wastewater flow or contaminant load shall be considered to occur:

a. For commercial facilities, public buildings, and places of employment, when there is a proposed change in occupancy of the structure; or the proposed modification affects either the type or number of plumbing appliances, fixtures or devices discharging to the system; and

b. For dwellings, when there is an increase or decrease in the number of bedrooms.

(d) *Documentation of existing capabilities.* Documentation to verify whether an existing POWTS can accommodate a modification in wastewater flow or contaminant load, or both, shall include at least one of the following:

1. A copy of the plan for the existing POWTS that delineates minimum and maximum performance capabilities and which has been previously approved by the department or the governmental unit.

2. Information on the performance capabilities for the existing POWTS that has been recognized through a product approval under ch. Comm 84.

3. A written investigative report prepared by an architect, engineer, designer of plumbing systems, designer of private sewage systems, master plumber, master plumber-restricted service or certified POWTS inspector analyzing the proposed modification and the performance capabilities of the existing POWTS.

(e) *Setbacks.* 1. A municipality may not issue a building permit for construction of any structure or addition to a structure on a site where there exists a POWTS, unless the proposed construction conforms to the applicable setback limitations under s. Comm 83.43 (8) (i).

2. The applicant for a building permit shall provide documentation to the municipality issuing the building permit showing the location and setback distances for the proposed construction relative to all of the following:

- a. Existing POWTS treatment components.
- b. Existing POWTS holding components.
- c. Existing POWTS dispersal components.

Note: A municipality which issues building permits may delegate to the governmental unit responsible for issuing sanitary permits the determination of whether the proposed construction will affect or interfere with an existing POWTS relating to capability or location of the existing POWTS.

A-50.10 to 50.25 FORMS The forms on the following 9 pages (SBD-2, SBD-118, SBD-224, SBD-9720 and SBC-9890) are referred to in ss. Comm 50.18, 50.12, 50.18, 50.10 and 50.25, respectively. Copies of these forms are available from the Division of Safety and Buildings, P.O. Box 7162, Madison, Wisconsin 53707.

A-50.21 CERTIFIED MUNICIPALITIES. The following municipalities have been certified by the department to review plans and conduct inspections under s. Comm 50.21. These lists are current as of the date of printing this code. Additions and deletions may occur during the effective period of this code. For information regarding the current status of a municipality, call 608-267-7586.

FIRST CLASS CITIES

Milwaukee

COUNTIES

Eau Claire

OTHER CITIES

Altoona	Fitchburg	Mequon	Seymour
Amery	Fond du Lac	Middleton	Sheboygan
Antigo	Fort Atkinson	Monroe	Stevens Point
Appleton	Franklin	Muskego	Sturgeon Bay
Augusta	Glendale	New Berlin	Sun Prairie
Beloit	Green Bay	New Richmond	Superior
Berlin	Greenfield	Oak Creek	Two Rivers
Black River Falls	Janesville	Oconomowoc	Waukesha
Brookfield	Kaukauna	Omro	Waupun
Burlington	Kenosha	Oshkosh	Wausau
Cedarburg	LaCrosse	Osseo	Wauwatosa
Cudahy	Lake Geneva	Racine	West Allis
Delafield	Madison	Rhineland	West Bend
Eau Claire	Marshfield	Ripon	Wisconsin Rapids
Elkhorn			

VILLAGES

Big Bend	Fredonia	Johnson Creek	Twin Lakes
Dousman	Grafton	Paddock Lake	Walworth
Dresser	Hartland	Plover	Waterford
Elm Grove	Hortonville	Port Edwards	Waunakee
Fall Creek	Howard	Silver Lake	West Milwaukee
Fontana	Jackson	Sussex	Whitefish Bay

TOWNS

Bloomfield (Walworth)	Geneva (Walworth)	Linn (Walworth)	Seymour (Eau Claire)
Bristol (Kenosha)	Grand Chute (Outagamie)	Mukwonago (Waukesha)	Sugar Creek (Walworth)
Cottage Grove (Dane)	Grand Rapids (Wood)	Norway (Racine)	Waterford (Racine)
Delavan (Walworth)	Hull (Portage)	Ottawa (Waukesha)	Waukesha (Waukesha)
Farmington (Polk)	LaGrange (Walworth)	Plover (Portage)	Wheatland (Kenosha)

Wisconsin Department of Industry,
Labor & Human Relations

INSPECTION REPORT AND ORDERS

Safety and Buildings Division
P. O. Box 7969, Madison, WI 53707

An inspection of the occupancy shown below discloses violations of orders of the Dept. of Industry, Labor and Human Relations promulgated under authority of Chapter 101, Wis. Stats. SEE REVERSE SIDE FOR APPLICABLE WISCONSIN STATUTES. Report when orders are completed. Avoid delay. Forfeiture for unresolved violations are \$10.00 to \$100.00 each day for each violation. Keep the Department informed.

"Failure of an employer to reasonably enforce compliance by employees with such statute or order of the Department shall constitute failure by the employer to comply with such statute or order" (s. 102.57, Wis. Stats.)

Inspection Date	Plan/Report Number	File Number	Page
		Inspection Type	
		Located At (number and street address)	
		City	County
		Violations Explained To	
		Compliance Date	

Note	Item	Orders and Requirements	✓ Done	X Not Done

SAMPLE

Deputy Name	Deputy's Office Hours and Telephone Number
-------------	--



**APPLICATION FOR REVIEW
BUILDINGS, HVAC, AND COMPONENTS**
-Complete all sides-

Safety & Buildings Division
Bureau of Integrated Services

INSTRUCTIONS: Please TYPE or PRINT clearly. Information on this form is important for providing you with timely and efficient scheduling and review of your project. Incomplete submittals cause delays in processing and potentially could result in a rescheduling of your review to a later date. Non-scheduled submittals or submittals received without a confirmed appointment date and transaction number on the form may be assigned to offices other than the receiving office depending on reviewer availability.

Complete for confirmed appointments:

Transaction ID: _____
 Previous Related Trans. ID: _____
 Appointment Date: _____
 Assigned Reviewer: _____
 Assigned Office: _____

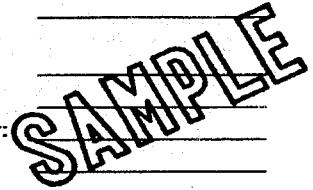

NOTE: Personal information you provide may be used for secondary purposes [Privacy Law s 15 04(1)(m)]

1. Appointment and Scheduling Information-- when submitted to Commerce for Plan Review

For submittals needing an appointment made in advance, call any of the full service offices listed below. **PLEASE HAVE THIS FORM COMPLETED PRIOR TO CALLING.** At the time of making an appointment, you may request review for a specific office or desired (beginning) date for review. You may also FAX a completed Application for Submittal and receive a FAX back Appointment Date, Transaction ID No. and Assigned Reviewer. Plans must be received in the office of the appointment no later than 2 working days before the confirmed appointment.

Madison S&BD 201 W Washington Ave PO Box 7162 Madison WI 53707-7162 608-266-3151 Fax: 608-261-6699 TDD 608-264-8777 Email: madisonsch@commerce.state.wi.us	Hayward S&BD 15837 USH 63 Hayward WI 54843 715-634-4870 Fax: 715-634-5150 Email: haywardsch@commerce.state.wi.us	LaCrosse S&BD 2226 Rose St LaCrosse WI 54603 608-785-9334 Fax: 608-785-9330 Email: lacrossesch@commerce.state.wi.us	Shawano S&BD 1340 E Green Bay Shawano WI 54166 715-524-3626 Fax: 715-524-3633 Email: shawanosch@commerce.state.wi.us	Green Bay S&BD 2331 San Luis Place Green Bay, WI 54304 920-492-5601 FAX: 920-492-5604 Email: greenbaysch@commerce.state.wi.us	Waukesha S&BD 401 Pilot Court Waukesha WI 53188 414-548-8600 Fax: 414-548-8614 Email: waukeshasch@commerce.state.wi.us
--	--	---	--	---	--

Check all that apply:

- Regular review
- Preliminary review
- Petition Attached

After plans are reviewed, please: (check all that apply)

- Call when completed.
- Will pick up.
- Comments: _____
- Mail plans to customer 1, 2, 3, 4 (circle number).
Circle customer number from customer information page.

2. Site Information

<input type="checkbox"/> City <input type="checkbox"/> Village <input type="checkbox"/> Town of Site ID No. _____ Previous Related Site ID No. _____	Legal Description Qtr. ____ Qtr. ____ Sec. ____ T. ____ N R. ____ (circle) E or W
County of _____ Zip+4 (9digits) _____	Tax parcel no. (contact county) Gov. Lot with legal description(if applicable)
Land Owner Type (check one) <input type="checkbox"/> County <input type="checkbox"/> Federal <input type="checkbox"/> Municipal <input type="checkbox"/> Private <input type="checkbox"/> State <input type="checkbox"/> Tribal Lands	Subdivision Name/Addition _____ Subdivision Lot No. _____ Driving directions to site _____
← ATTACH CHECK HERE	Facility Name/Tenant Space (Ex : West Mall/Jim's Shoes) Facility Address (street number and street name/zipcode+4) _____

3. Fees Submitted for Review Request

See back page for fee calculations. Provide Total Amount Due in the space provided and attach check.

MAKE CHECKS PAYABLE TO COMMERCE.	TOTAL AMOUNT DUE (See Fee Calculation on back of application.)	\$ _____ Revenue Code 7648
---	--	-------------------------------

Further Information on Reverse Side →

4. Items Submitted for Review

Regulated Objects (former terms) Submitted For Review	FEE	Regulated Object Description
1. Building (<input type="checkbox"/> new, <input type="checkbox"/> addition, <input type="checkbox"/> alteration, <input type="checkbox"/> revision)		
2. HVAC System		
3. Soil Erosion Control		
4. Structural Component		
5. Structure (non-occupied, non- building)		
6. Lighting System		
7. Petition for Variance (attach separate application)		
8. Permission to start (additional \$80 fee)		
Total Fees		← Carry total to front page

5. Regulated Object Type Details Complete information requested where applicable.

Building		Structure
Number of Floor Levels _____ Number of Stories _____ Total Floor Area _____ sf	(Type of Construction) <input type="checkbox"/> 1 <input type="checkbox"/> 2 <input type="checkbox"/> 3 <input type="checkbox"/> 4 <input type="checkbox"/> 5A <input type="checkbox"/> 5B <input type="checkbox"/> 6 <input type="checkbox"/> 7 <input type="checkbox"/> 8	Structure Type <input type="checkbox"/> Antenna Tower <input type="checkbox"/> Tower <input type="checkbox"/> Canopy <input type="checkbox"/> Exterior Bleacher
Footings and Foundation only? <input type="checkbox"/> Yes <input type="checkbox"/> No	Sprinklered Type <input type="checkbox"/> Partial <input type="checkbox"/> Complete <input type="checkbox"/> None <input type="checkbox"/> NFPA 13 <input type="checkbox"/> NFPA 13R <input type="checkbox"/> NFPA 231 <input type="checkbox"/> NFPA 231C	Construction Material (for ILHR 62 only) <input type="checkbox"/> Completely Noncombustible <input type="checkbox"/> Combustible <input type="checkbox"/> Partially Noncombustible <input type="checkbox"/> <input type="checkbox"/> NC-0 <input type="checkbox"/> NC-2
Occupancy Type (check all that apply) <input type="checkbox"/> Assembly (Entertainment, Dining, Worship) <input type="checkbox"/> Business/Office <input type="checkbox"/> Educational <input type="checkbox"/> Factory/Industrial <input type="checkbox"/> Mercantile/Retail <input type="checkbox"/> Hazardous/Garage <input type="checkbox"/> Institutional/Daycare/CBRF <input type="checkbox"/> Free Standing Canopy <input type="checkbox"/> Grandstand <input type="checkbox"/> Open Parking Structure <input type="checkbox"/> Mini-Storage	Component Included with this submittal (check all that apply): <input type="checkbox"/> Precast Concrete <input type="checkbox"/> Wood Truss <input type="checkbox"/> Steel Joist Girder <input type="checkbox"/> Metal Building <input type="checkbox"/> Laminated Wood <input type="checkbox"/> Fire Escape <input type="checkbox"/> Interior Bleacher	Erosion Control Disturbed Area: _____ acres
Fire Containment (check all that apply) <input type="checkbox"/> Unlimited Area <input type="checkbox"/> Flammable or Combustible Liquids <input type="checkbox"/> Required Area Division Walls	HVAC Submittal Includes, Check all that apply <input type="checkbox"/> Grease/Range Hood <input type="checkbox"/> VAV System <input type="checkbox"/> Boilers <input type="checkbox"/> Seasonal Use Dates _____ to _____ <input type="checkbox"/> Plenum Ceiling <input type="checkbox"/> Mechanical Refrigeration Over 50 Tons	Site Easements from Others? <input type="checkbox"/> <input type="checkbox"/> Yes <input type="checkbox"/> No Site ID (or address) of Others Giving Easements: _____
Facility Regulated by Other Agency (check all that apply) <input type="checkbox"/> CBRF <input type="checkbox"/> Hospital <input type="checkbox"/> Nursing Home <input type="checkbox"/> Day Care <input type="checkbox"/> Assisted Living <input type="checkbox"/> Hotel/Motel/Restaurant <input type="checkbox"/> Public Swimming Pool <input type="checkbox"/> Other <input type="checkbox"/> None	HVAC Fuel Source <input type="checkbox"/> Oil/LPG <input type="checkbox"/> Gas <input type="checkbox"/> Solid <input type="checkbox"/> Electrical	Lighting Light Load in KW _____ Lighting Controls <input type="checkbox"/> Day Lighting <input type="checkbox"/> Shut Off <input type="checkbox"/> Light Reduction <input type="checkbox"/> None

6. Components Submitted Separate from Building

The department expects, and requires that the project designer review individual component submittals for compliance with the general design concept. The project designer, and department, will reply on the seal of the component designers for compliance with the code as they apply to their designs.

Original Signature of Building Designer (Component Submittal)	Date Signed	Name of Component Fabricator
---	-------------	------------------------------

7. Permission to start requested

As the owner, I request to begin footing and foundation work PRIOR to plan review approval. I agree to make any changes required after plans have been reviewed, and to remove or replace any non-code complying construction. (Additional \$80.00 Fee)

Owner's Signature _____

8. Statements of (Owner's, Designer's, and Supervising Professional's signatures required below)

- a) **Owners** I request that plans be reviewed for compliance with the code requirements set forth in Chs. ILHR 50-64, 66, and 69 of the department. I recognize that I am responsible for compliance with all the code requirements and any conditions of approval. If this building exceeds 50,000 cubic feet in total volume, I will retain as required by s. ILHR 50.10, a supervising professional through out construction to project completion and the filing of a Compliance Statement by the supervising professional prior to occupancy.
- b) **DESIGNERS** (ILHR 50.07-50.09) If this building, following construction of this project, contains more that 50,000 cubic feet in total volume, plans are required to be prepared, signed, sealed and dated by a Wisconsin registered engineer or architect (ILHR 50.07(2)). Signatures and seals shall be original. I certify that the submitted plans were prepared under my supervision, are accurate, and to the best of my knowledge comply with the applicable codes of the Division of Safety & Buildings.
- c) **SUPERVISING PROFESSIONALS** (ILHR 50.10) I have been retained by the owner as the supervising professional per ILHR 50.10 for the performance of the supervision of reasonable on-the-site observations to determine if the construction is in substantial compliance with the approved plans and specifications. Upon completion of construction, I will file a written statement with the department certifying that, to the best of my knowledge and belief, construction has or has not been performed in substantial compliance with the approved plans and specifications.

<p>1) Customer Information</p> <p>Individual (or business contact) _____ (First) Middle Last, Suffix)</p> <p>Customer Type (check all that apply) <input type="checkbox"/> Owner/Owner's Agent <input type="checkbox"/> Payer (on check) <input type="checkbox"/> Designer <input type="checkbox"/> Bldg <input type="checkbox"/> HVAC <input type="checkbox"/> Lighting <input type="checkbox"/> Supervising Professional <input type="checkbox"/> Bldg <input type="checkbox"/> HVAC <input type="checkbox"/> Lighting <input type="checkbox"/> Other _____</p> <p>Business Name (if applicable) _____</p> <p>PO Box _____ Zip+4 (9digits) _____</p> <p>City _____ State _____</p> <p>Phone Number (area code) <input type="checkbox"/> Work <input type="checkbox"/> Home _____</p> <p>Fax Number (area code) <input type="checkbox"/> Work <input type="checkbox"/> Home _____</p> <p>Internet/E-mail Address _____</p> <p>Signature (if applicable) _____ Customer ID No. _____</p>	<p>2) Customer Information</p> <p>Individual (or business contact) _____ (First) Middle Last, Suffix)</p> <p>Customer Type (check all that apply) <input type="checkbox"/> Owner/Owner's Agent <input type="checkbox"/> Payer (on check) <input type="checkbox"/> Designer <input type="checkbox"/> Bldg <input type="checkbox"/> HVAC <input type="checkbox"/> Lighting <input type="checkbox"/> Supervising Professional <input type="checkbox"/> Bldg <input type="checkbox"/> HVAC <input type="checkbox"/> Lighting <input type="checkbox"/> Other _____</p> <p>Business Name (if applicable) _____</p> <p>PO Box _____ Zip+4 (9digits) _____</p> <p>City _____ State _____</p> <p>Phone Number (area code) <input type="checkbox"/> Work <input type="checkbox"/> Home _____</p> <p>Fax Number (area code) <input type="checkbox"/> Work <input type="checkbox"/> Home _____</p> <p>Internet/E-mail Address _____</p> <p>Signature (if applicable) _____ Customer ID No. _____</p>
<p>3) Customer Information</p> <p>Individual (or business contact) _____ (First) Middle Last, Suffix)</p> <p>Customer Type (check all that apply) <input type="checkbox"/> Owner/Owner's Agent <input type="checkbox"/> Payer (on check) <input type="checkbox"/> Designer <input type="checkbox"/> Bldg <input type="checkbox"/> HVAC <input type="checkbox"/> Lighting <input type="checkbox"/> Supervising Professional <input type="checkbox"/> Bldg <input type="checkbox"/> HVAC <input type="checkbox"/> Lighting <input type="checkbox"/> Other _____</p> <p>Business Name (if applicable) _____</p> <p>PO Box _____ Zip+4 (9digits) _____</p> <p>City _____ State _____</p> <p>Phone Number (area code) <input type="checkbox"/> Work <input type="checkbox"/> Home _____</p> <p>Fax Number (area code) <input type="checkbox"/> Work <input type="checkbox"/> Home _____</p> <p>Internet/E-mail Address _____</p> <p>Signature (if applicable) _____ Customer ID No. _____</p>	<p>4.) Customer Information</p> <p>Individual (or business contact) _____ (First) Middle Last, Suffix)</p> <p>Customer Type (check all that apply) <input type="checkbox"/> Owner/Owner's Agent <input type="checkbox"/> Payer (on check) <input type="checkbox"/> Designer <input type="checkbox"/> Bldg <input type="checkbox"/> HVAC <input type="checkbox"/> Lighting <input type="checkbox"/> Supervising Professional <input type="checkbox"/> Bldg <input type="checkbox"/> HVAC <input type="checkbox"/> Lighting <input type="checkbox"/> Other _____</p> <p>Business Name (if applicable) _____</p> <p>PO Box _____ Zip+4 (9digits) _____</p> <p>City _____ State _____</p> <p>Phone Number (area code) <input type="checkbox"/> Work <input type="checkbox"/> Home _____</p> <p>Fax Number (area code) <input type="checkbox"/> Work <input type="checkbox"/> Home _____</p> <p>Internet/E-mail Address _____</p> <p>Signature (if applicable) _____ Customer ID No. _____</p>

9. Certified Agent Municipalities Authorized by the State to Conduct Plan Review

Per s. COMM/ILHR 50.21, the following municipalities have been certified to review plans for new buildings containing less than 5,000 sq. ft., total area; additions to existing buildings where the total area after construction of the addition is less than 5,000 sq. ft.; and alterations to existing buildings where the area of altered space is less than 10,000 sq. ft. If your project is located within the limits of a listed municipality, and meets the size criteria, then contact the municipality involved. **Municipalities marked with an asterisk (*) have been authorized to review plans without limit on size of project or building.** For information regarding the current status of a municipality, call 608-267-7586.

COUNTIES

Eau Claire

TOWNS (County Location)

Bloomfield (Walworth)	Geneva (Walworth)	Linn (Walworth)	Seymour (Eau Claire)
Bristol (Kenosha)	Grand Chute (Outagamie)	Mukwonago (Waukesha)	Sugar Creek (Walworth)
Cottage Grove (Dane)	Grand Rapids (Wood)	Norway (Racine)	Waterford (Racine)
Delavan (Walworth)	Hull (Portage)	Ottawa (Waukesha)	Waukesha (Waukesha)
Farmington (Polk)	LaGrange (Walworth)	Plover (Portage)	Wheatland (Kenosha)

CITIES & VILLAGES

Altoona	Delafield	Fredonia	Kenosha	Oak Creek	Seymour	Waunakee
Antigo	Dousman	Glendale	La Crosse	Oconomowoc	Sheboygan	Waupun
Appleton	Dresser	Grafton	Lake Geneva	Omro	Silver Lake	Wausau
Augusta	Eau Claire	Green Bay	Madison*	Osceola	Stevens Point	Wauwatosa
Beloit	Elkhorn	Greenfield	Marshfield	Oshkosh	Sturgeon Bay	West Allis
Berlin	Elm Grove	Hartland	Mequon	Osseo	Sun Prairie	West Bend
Big Bend	Fall Creek	Hortonville	Middleton	Paddock Lake	Superior	West Milwaukee
Black River Falls	Fitchburg	Howard	Milwaukee*	Plover	Sussex	Weyauwega
Brookfield	Fond du Lac	Janesville*	Monroe	Port Edwards	Twin Lakes	Whitefish Bay
Burlington	Fontana	Jackson	Muskego	Racine	Walworth	Wis Rapids
Cedarburg	Fort Atkinson	Johnson Creek	New Berlin	Rhineland	Waterford	
Cudahy	Franklin	Kaukauna	New Richmond	Ripon	Waukesha	

10. Fee Calculation Instructions

FEE SCHEDULE SUMMARY: WISCONSIN BUILDING CODE
Effective January 1, 1998

1. Building, heating and ventilation, lighting plans. Fees relating to the submittal of all building and heating and ventilation plans (new, addition, alteration) shall be computed on the basis of the total gross floor area of each building, area of addition or area of alteration and shall be determined in accordance with Table COMM 2.31-1 or Table 2.31-2.

AREA: The area of a building is the area bounded by the exterior surface of the building walls or the outside face of columns where there is no wall. Area includes all roofed areas included porches and garages, except for cantilevered canopies on the building wall. Use the roof area for free standing canopies. Total gross floor area is the summation of all the floor levels, including mezzanines.

Note: COMM 2 provides for a partial fee refund if a plan action has not been taken within 15 days of receipt of all required information

Area (sq ft)	Table COMM 2.31-1: For Projects Not Located in Certified Municipalities			Table COMM 2.31-2: For Projects Located In Certified Municipalities		
	Building and HVAC	Building ONLY	HVAC OR Lighting Only	Building and HVAC	Building ONLY	HVAC OR Lighting Only
Less than 2,500	\$ 320	\$ 270	\$ 190	\$ 290	\$ 240	\$ 170
2,501 - 5,000	430	320	240	390	290	220
5,001 - 10,000	580	480	270	520	430	240
10,001 - 20,000	900	630	370	810	570	330
20,001 - 30,000	1,280	900	480	1,150	810	430
30,001 - 40,000	1,690	1,220	690	1,530	1,100	630
40,001 - 50,000	2,280	1,590	900	2,060	1,440	810
50,001 - 75,000	3,080	2,120	1,220	2,780	1,910	1,100
75,001 - 100,000	3,880	2,600	1,690	3,500	2,350	1,530
100,001 - 200,000	5,940	4,240	2,120	5,350	3,830	1,910
200,001 - 300,000	12,200	7,430	4,700	11,000	6,700	4,310
300,001 - 400,000	17,190	11,140	6,900	15,550	10,050	6,220
400,001 - 500,000	21,220	13,790	9,020	19,140	12,440	8,130
Over 500,000	22,810	14,850	10,080	20,570	13,400	9,090

Note: A fee reduction may be taken for plans involving multiple identical buildings located on the same site and submitted at the same time: The fees for the submittal of building, heating and ventilation plans for their first building shall be determined in accordance with the appropriate Table 2.31-1 or 2.31-2 on the basis of the total gross area of one building. The fee for each of the remaining identical buildings shall be computed on the basis of an area of less than 2,500 square feet.

II	Miscellaneous Plans	\$250	Miscellaneous plans include: footing & foundation (submitted separately); grandstand; bleacher; exhaust system & spray booth (govt. owned); docks; antennas; observation towers; structural plans submitted as independent projects and other submittals not listed.
	Revision to Previously Examined Plan	\$100	No fee if revision requested by plan examiner. Also applies to revisions or re-considerations of previously approved Petitions For Variance.
	Permission to Start (Optional)	\$80	Applies only to projects with footings and foundations.
	HVAC Equipment Replacement	\$80	Applies only if no duct or piping alterations.
	All other types not mentioned elsewhere		Contact any of the full service offices listed.

Wisconsin Department of Industry
Labor & Human Relations

INSPECTION PROGRESS REPORT

Safety and Buildings Division
P.O. Box 7969, Madison, WI 53707

RE:	File Number E-	Plan No.
	Inspection Date:	
	No. 1.	Person Contacted
	2.	
	3.	
	Bldg. Final	
	H & V Final	
	Other Final	
	Compliance Date:	
	Office Instruction (Check one):	
<input type="checkbox"/> Voluntary Compliance <input type="checkbox"/> Process SB-2 <input type="checkbox"/> Violations explained to owner		

TO:

INSPECTION				INSPECTION FINDINGS
<input checked="" type="checkbox"/> Order Corrected <input type="checkbox"/> Order Not Corrected				Items listed below should be corrected before the next inspection or final inspection. These items are violations of the Building Code sections noted.
1	2	3	Final	
				SAMPLE

Owner's Name and Address (if different from above):	Deputy's Name: Deputy's Signature: Deputy's Office Hours and Telephone Number:
---	--

SBD-224 (R. 07/88)

Compliance Statement

This form is required to be submitted by the supervising professional (architect, engineer, HVAC designer or electrical designer) observing construction of projects within buildings with total areas exceeding 50,000 cubic feet and construction of antennas, towers, and bleachers (ILHR 50.10). Failure to submit this form may result in penalties as specified in ILHR 50.26 and/or local ordinances.

General Instructions: Prior to the initial occupancy of new buildings or additions and the final occupancy of altered existing buildings, submit this completed and signed form to:

- The municipal building inspection office and
- Safety and Buildings, P.O. Box 7969, Madison, WI 53707-7969

Personal information you provide may be used for secondary purposes [Privacy Law, s. 15.04 (1)(m)].

1. PROJECT INFORMATION: (Use the Safety and Buildings or municipal project label, or type or print the information. If label is used, no additional entry is needed on Part 1.

Owner Information

Project Information

L
A
B
E
L
H
E
R
E

Name	Building Occupancy Chapter(s) & Use
Company Name	Tenant Name (if any)
Number and Street	Building Location (number & street)
City	<input type="checkbox"/> City <input type="checkbox"/> Village <input type="checkbox"/> Town of _____ County of _____
State and Zip Code	Property Identification Number
Plan or Reference Number	Name & Reg. # of Supervising Prof. for <input type="checkbox"/> Building <input type="checkbox"/> HVAC <input type="checkbox"/> Lighting
Name & Reg. # of Supervising Prof. for <input type="checkbox"/> Building <input type="checkbox"/> HVAC <input type="checkbox"/> Lighting	Name & Reg. # of Supervising Prof. for <input type="checkbox"/> Building <input type="checkbox"/> HVAC <input type="checkbox"/> Lighting

SAMPLE

2. PURPOSE OF THIS STATEMENT: (Check Box A, B, C, or D to indicate purpose and complete any other applicable boxes and information. Attach additional pages if necessary.)

Check those which apply: Building HVAC Lighting
 Partial Completion

Description of Portion Completed _____

A) Statement of Substantial Compliance

To the best of my knowledge, belief, and based on onsite observation, construction of the following building and/or HVAC items applicable to this project have been completed in substantial compliance with the approved plans and specifications.

BUILDING ITEMS

1. Structural system including submittal and erection of all building components (trusses, precast, metal building, etc.)
2. Fire protection systems (sprinklers, alarms, smoke detectors) designed, installed, and tested (including forward flow on back flow devices) by appropriately registered professionals
3. Shaft and stairway enclosure
4. Exits including exit and directional lights
5. Fire-resistive construction, enclosure of hazards, fire walls, labeled doors, class of construction
6. Sanitation system (toilets, sinks, drinking facilities)
7. ILHR barrier-free requirements
8. All conditions of building plan approval and applicable variances

HVAC ITEMS

1. HVAC system including final test (ILHR 64.53)
2. All conditions of HVAC plan approval and applicable variances

LIGHTING ITEMS

1. Exterior lighting & control requirements
2. Interior lighting & control requirements
3. All conditions of lighting plan approval and applicable variances

The following items are not in compliance and must be addressed: _____

B) Statement of Noncompliance

Due to the following listed violations, this project is not ready for occupancy: _____

C) Supervising Professional Withdrawn From Project (Use A or B above to indicate project status as of this date.)

D) Project Abandoned

3. SUPERVISING PROFESSIONAL SIGNATURES FOR:

Building HVAC Lighting _____ Date _____

Building HVAC Lighting _____ Date _____

Building HVAC Lighting _____ Date _____



SAFETY AND BUILDINGS DIVISION
 201 West Washington Avenue
 P. O. Box 7162
 Madison, Wisconsin 53707

Tommy G. Thompson, Governor
 William J. McCoshen, Secretary

Dear Supervising Professional:

Enclosed are labels for projects approved by the department for which our records indicate that you are supervising professional. For your convenience, compliance forms SBD-9720 are enclosed. Additional copies can be made if necessary. Please attach a project label to a compliance statement for each project for which statement A, B, C or D below is applicable. If the project is not complete enough at this time to be considered in substantial compliance, please save the label for future submittal. If you use a label no additional entry on Part I is needed. Just check the appropriate box and sign and date the form. Return the original completed form to:

SAFETY AND BUILDINGS DIVISION
 P.O. BOX 7162
 MADISON, WI 53707

PLEASE send a copy to the
 local municipality that
 issued the occupancy permit

If you have any questions, please contact Gloria Kocovsky at 608/261-8460 or Jennifer Oldenburg 608/261-8461.

- A SATISFACTORY COMPLETE PROJECT - This category indicates that the project has been completed and to the best of your knowledge and belief, construction has been performed in substantial compliance with the approved plans and specifications.
- B STATEMENT OF NONCOMPLIANCE - This category indicates that the project has been completed but does not substantially comply with the approved plans and specifications. The supervising professional will be required to list those areas that are not in compliance in Part 2B of the compliance statement.
- C SUPERVISING PROFESSIONAL WITHDRAWN - Use this category to notify the department so that the owner can be requested to provide the name and registration number of the new professional prior to continuing with the project. Note that when withdrawing from a project, it is necessary to complete part 2A or 2B of the compliance statement to indicate the project status at the time of withdrawal.
- D ABANDONED PROJECT - This category indicates that the project is not going to be constructed.

SAMPLE LABEL

COMPLIANCE STATEMENT LABEL
 OCCUPANCY
 OWNER
 TENANT
 BUILDING ADDRESS
 MUNICIPALITY
 PLAN NUMBER

Sincerely,

Randall V. Baldwin

Randall V. Baldwin, Director
 Integrated Services Bureau

SBD-5524-E (R 04/97)

File Ref: S:\DIVINTSVCI\COMPLNCE DOC

Safety and Buildings Division
Bureau of Integrated Services

PETITION FOR VARIANCE APPLICATION

Dept. Use Only
Plan No _____
Amount Paid _____

Page 1 of _____

PLEASE TYPE OR PRINT CLEARLY - Personal information you provide may be used for secondary purposes [Privacy Law, s.15.04 (1)(m)].

1. Owner Information		2. Project Information		3. Designer Information	
Name		Building Occupancy Chapter(s) and Use		Designer	Registration No
Company Name		Tenant Name (if any)		Design Firm	
Number and Street		Building Location (number and street)		Number and Street	
City, State, Zip Code		<input type="checkbox"/> City <input type="checkbox"/> Village <input type="checkbox"/> Township of		City, State Zip Code	
Contact Person		County of		Contact Person	
Telephone Number ()	FAX Number ()	Property ID # (tax parcel # - contact county)		Telephone Number ()	FAX Number ()

4. Plan Review Status

<input type="checkbox"/> On hold	<input type="checkbox"/> Already built
<input type="checkbox"/> Preliminary design	<input type="checkbox"/> Built according to older code but must be brought into compliance with current code
<input type="checkbox"/> State <input type="checkbox"/> Municipality	<input type="checkbox"/> Approved, requesting revision
<input type="checkbox"/> Submitted with petition	<input type="checkbox"/> Plan will be submitted after petition determination
	<input type="checkbox"/> Other

Plan Number _____

5. State the code section being petitioned AND the specific condition or issue you are requesting be covered under this petition for variance.

SAMPLE

6. Reason why compliance with the code cannot be attained without the variance. _____

7. State your proposed means and rationale of providing equivalent degree of health, safety, or welfare as addressed by the code section petitioned.

8. List attachments to be considered as part of the petitioner's statements (i.e., model code sections, test reports, research articles, expert opinion, previously approved variances, pictures, plans, sketches, etc.).

VERIFICATION BY OWNER - PETITION IS VALID ONLY IF NOTARIZED WITH AFFIXED SEAL AND ACCOMPANIED BY REVIEW FEE (See Section ILHR 2.52 for complete fee information)

Note: Petitioner must be the owner of the building or project. Tenants, agents, designers, contractors, attorneys, etc., shall not sign petition unless Power of Attorney is submitted with the Petition for Variance Application

_____, being duly sworn, I state as petitioner that I have read the foregoing petition and I believe it is true and that I have significant ownership rights to the subject building or project.

Petitioner's Signature	Subscribed and sworn to before me this date	Notary Public	My commission expires on
------------------------	---	---------------	--------------------------

Complete other side for variance requests from ILHR 20-25 and ILHR 50-64

Owner's Name	Project Location	Plan Number
--------------	------------------	-------------

Page 2 of _____

Fire Department Position Statement

To be completed for variances requested from ILHR 50-64, ILHR 69, ILHR 10, and other fire related requirements

I have read the application for variance and recommend: (check appropriate box)

- Approval
 Conditional Approval
 Denial
 No Comment

Explanation for recommendation including any conflicts with local rules and regulations and suggested conditions:

Fire Department Name and Address

Name of Fire Chief or Designee (type or print)

Telephone Number

Signature of Fire Chief or Designee

Date Signed

MUNICIPAL BUILDING INSPECTION RECOMMENDATION

To be completed for variances requested from ILHR 20-23. Also to be used if ILHR 50-64 plan review is by municipality or orders are written on the building under construction; optional in other cases.

I have read the application for variance and recommend: (check appropriate box)

- Approval
 Conditional Approval
 Denial
 No Comment

Explanation for recommendation including any conflicts with local rules and regulations and suggested conditions:

Municipality Exercising Jurisdiction

Name and Address of Municipal Official (type or print)

Telephone Number of Enforcement Official

Signature of Municipal Enforcement Official

Date Signed

A-51.01 (12) BUILDING. The intent was to consider permanent awnings as part of a building.

A-51.01 (42) FAMILY. The intent of this definition is to clarify the use of the word "family" in reference to s. Comm 51.01 (102a); it is not intended as a variance to the definition stated under s. Comm 51.01 (102a) (b).

A-51.01 (67a) HABITABLE ROOM. It is the intent that rooms designated as recreation, study, den, family room, office, etc. and providing the only space for living and/or sleeping are considered

habitable rooms.

A-51.01 (115) SETBACK. The intent was to not include gutters, downspouts, outdoor lighting fixtures, signs and similar attachments as part of a building.

To determine the portion of a wall (A) that is within a distance X from a property line or another building, extend the wall face to its intersection with the property line or other building. Bisect the angle formed by the intersection. Measure X perpendicular to the bisector. Repeat these steps for wall face B.

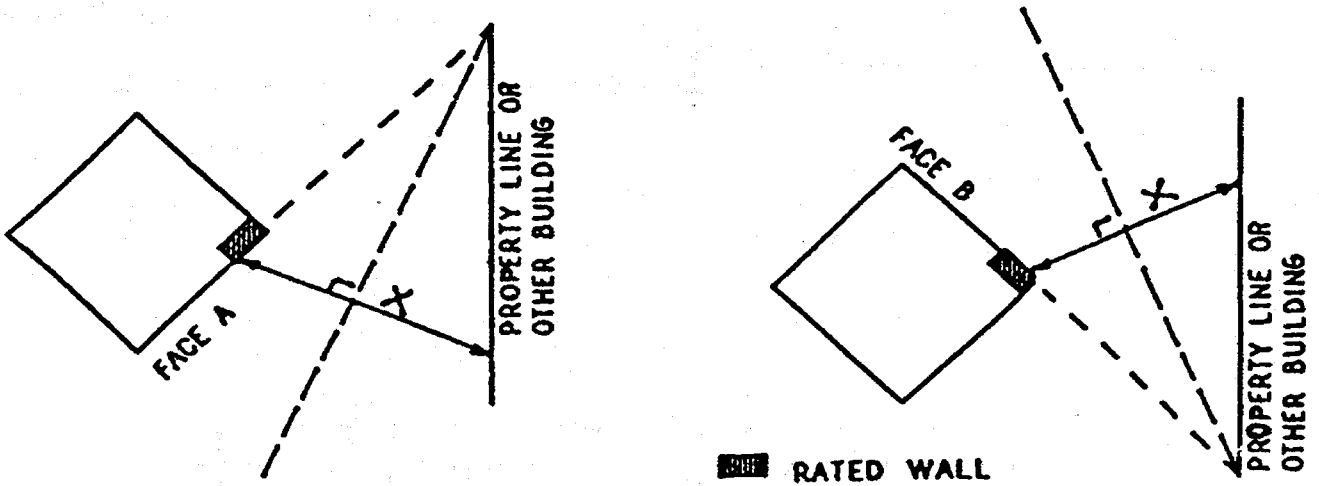

The following sketch shows setback measurements between intersecting or projected intersection of building faces.

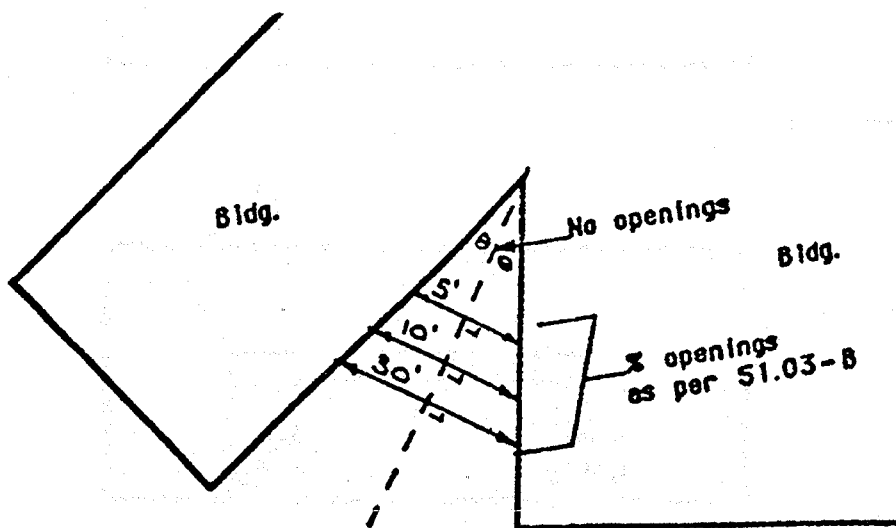

A-51.01 (121) STORIES, NUMBER OF. For further clarification, refer to A-51.02 (14).

A-51.01 (144) WALL (DIVISION).

(a) *Building division wall* is intended to denote a wall constructed in a manner sufficient to meet requirements for a party wall [see "Wall (Party)"] and is acceptable as a dividing wall or enclosing wall when determining the volume of a building as referred to in ss. Comm 50.07, 50.10 and 50.12.

(b) *Fire division wall* is intended to relate to construction that provides separation between portions of a building to satisfy allow-

able floor area limitations, separation between 2 classes of construction, or separation of hazardous occupancies. For other separations, see "occupancy separations" and isolation of hazards sections of this code.

A-51.01 (151) WALL (PARTY). It is intended that a property consisting of joining plotted subdivisions owned by one individual, that can be owned by separate individuals, is included in the definition of party wall.

A-51.02 (14) DETERMINATION OF NUMBER OF STORIES. The following illustrations are provided to give visual aid to this rule and the definition of s. Comm 51.01 (121) Stories, Number of.

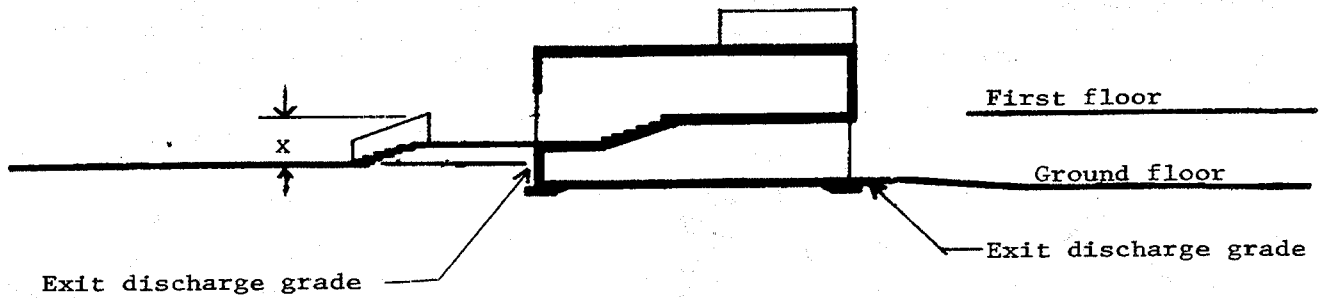

Note: X = 6'-0" (maximum)

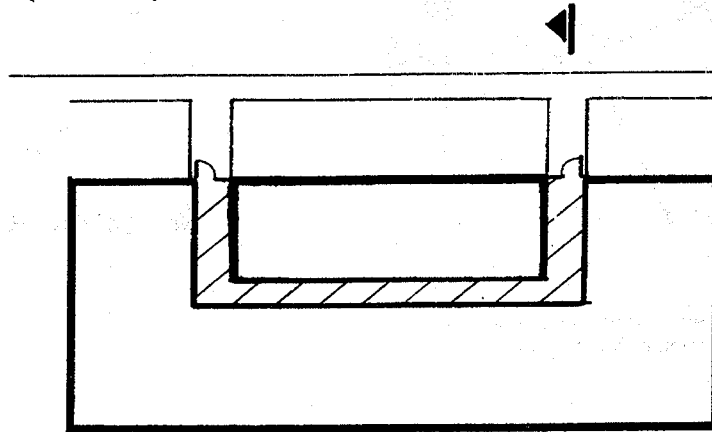

Ground floor

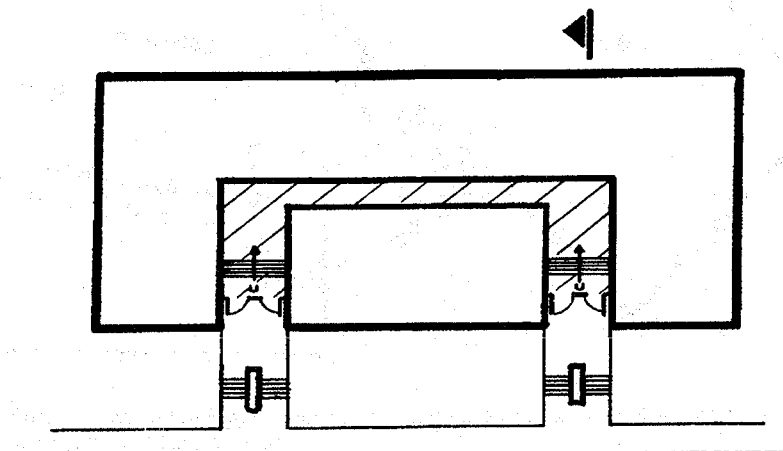

First floor

A-51.03 (5) (a) EXTERIOR MASONRY CONSTRUCTION. The following Figures 1, 2, 3, 4, 5A and 5B illustrate typical details for vari-

ous wall construction alternatives, which satisfy the intent of this rule for Type 5—Exterior Masonry Construction.

Required Hourly Rating for Wall Achieved by Masonry Component

Note:

Masonry wall must be laterally supported by horizontal structural components only (i.e., floor, floor/ceiling or roof/ceiling assemblies). Optional furring/insulation system, if used, cannot be used to provide required lateral support for masonry wall.

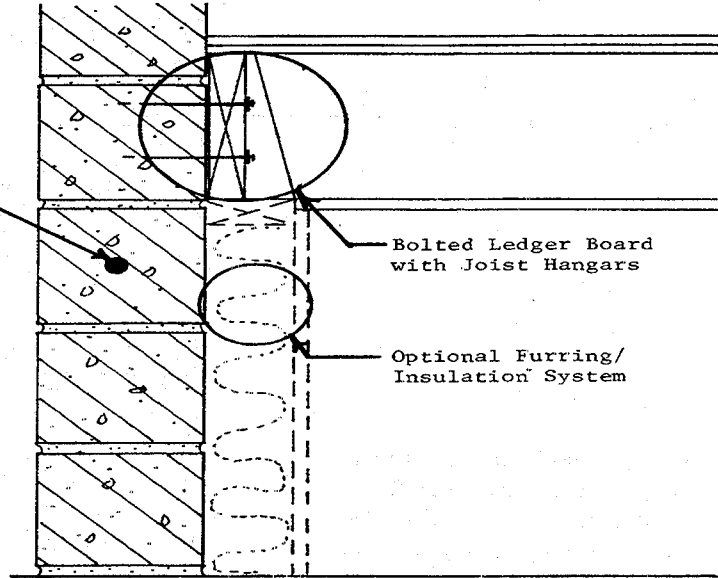

FIGURE 1
Single Wythe Masonry Wall
(Bearing Condition)

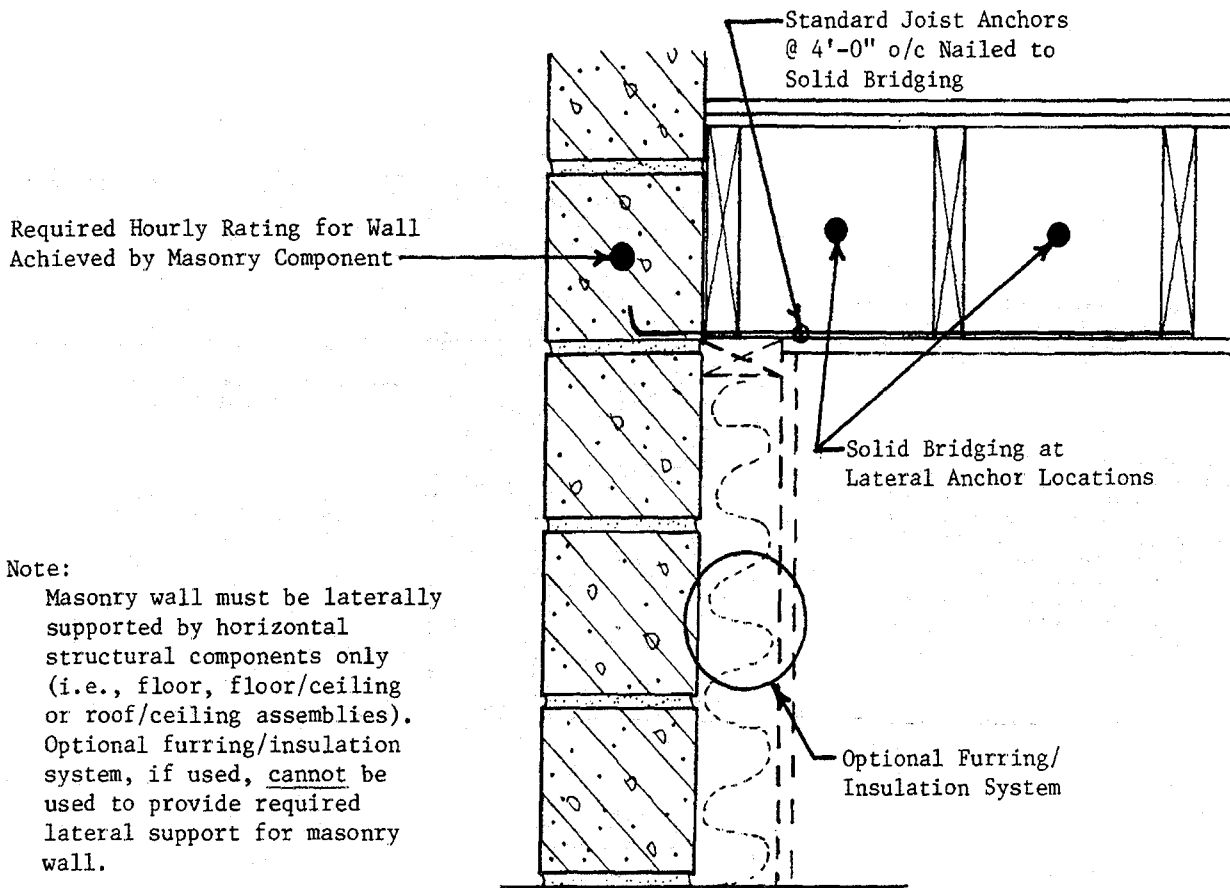

FIGURE 2
 Single Wythe Masonry Wall
 (Non-Bearing Condition)

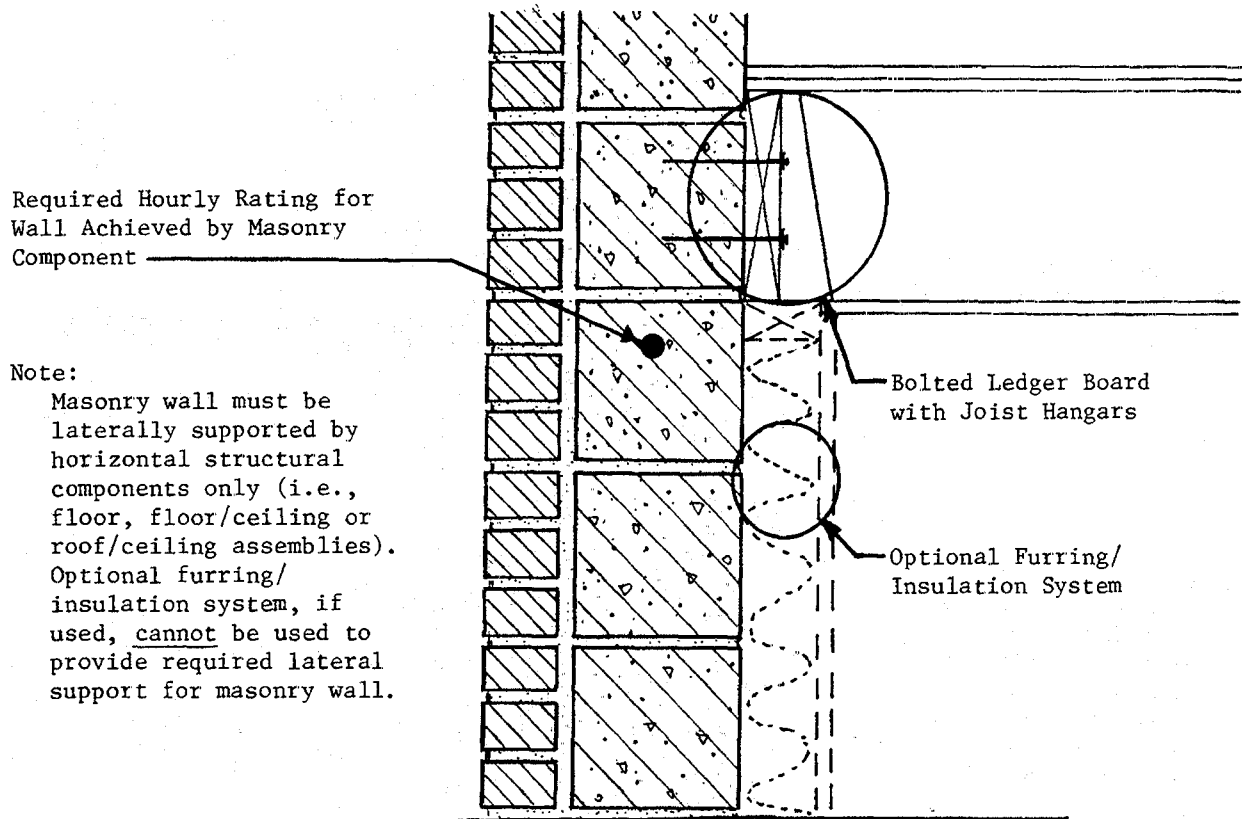

FIGURE 3
Multi-Wythe Masonry Wall
(Bearing Condition)

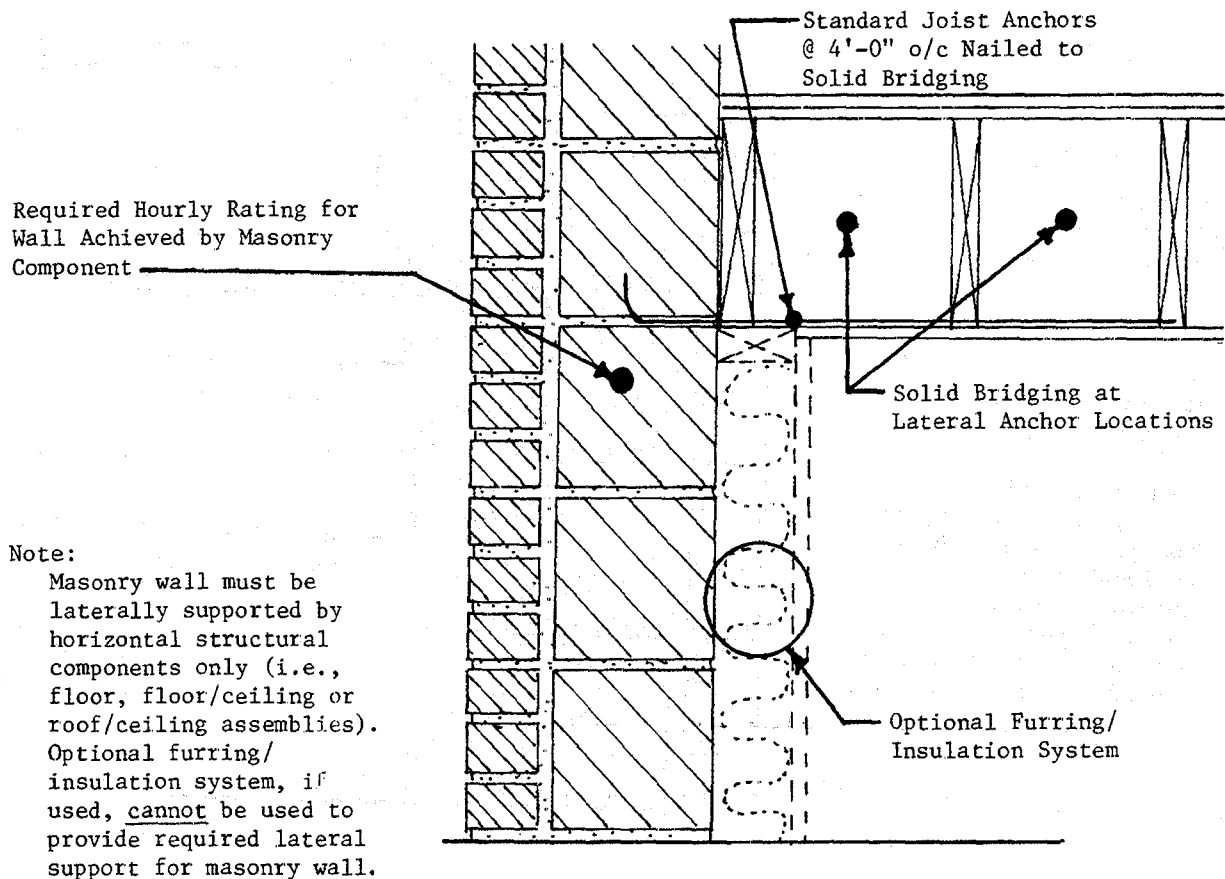

FIGURE 4
 Multi-Wythe Masonry Wall
 (Non-Bearing Condition)

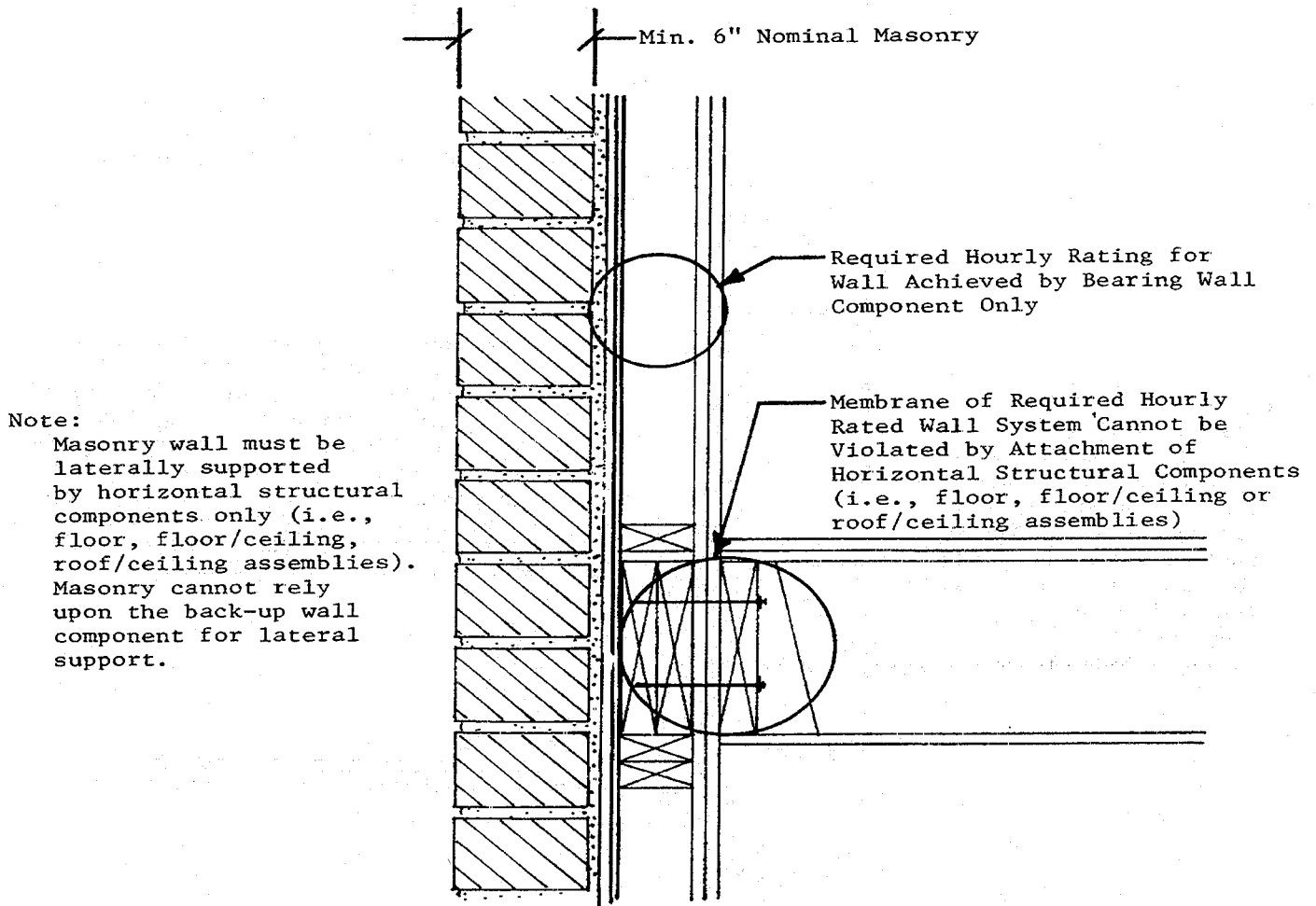
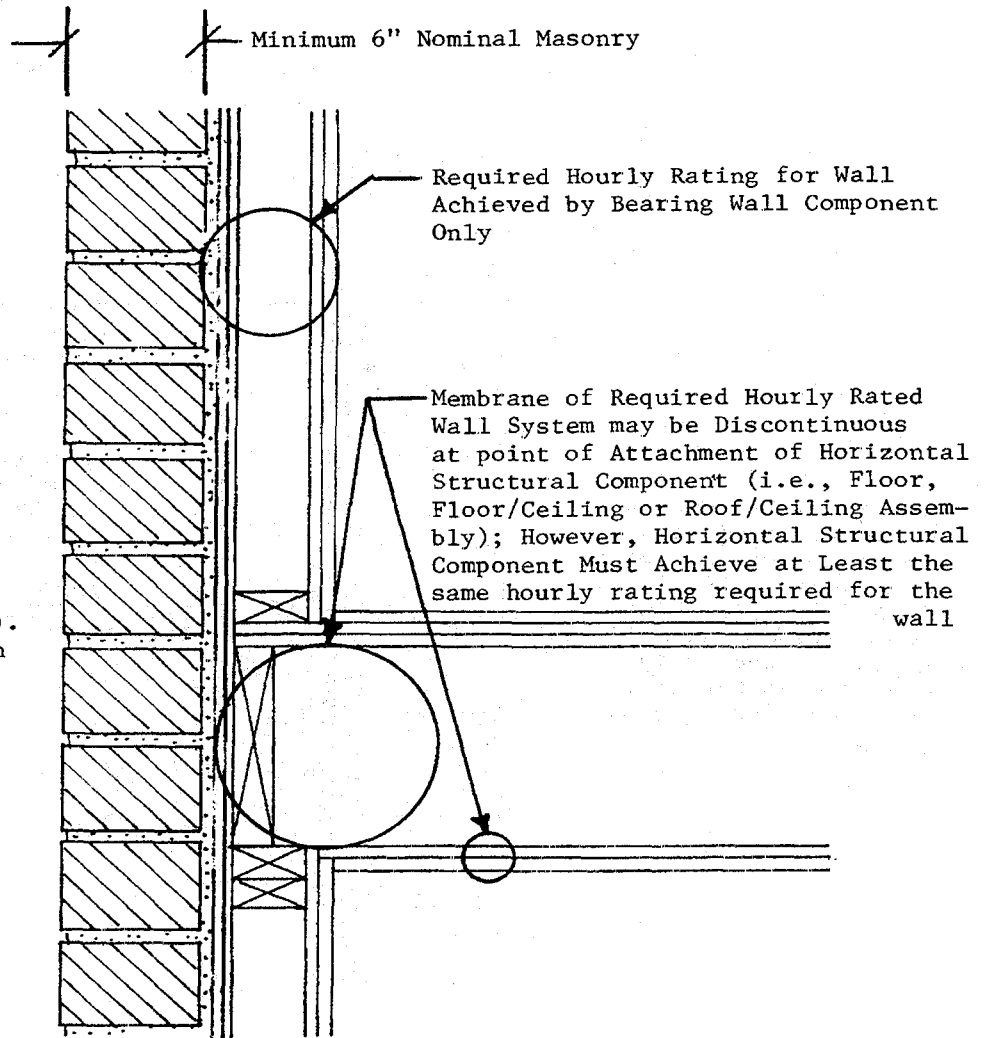

FIGURE 5A
Combination Masonry/Frame Wall
(Bearing and Non-Bearing Condition)



Note:

Masonry wall must be laterally supported by horizontal structural components only (i.e., floor, floor/ceiling or roof/ceiling assemblies). Masonry cannot rely upon the back-up wall component for lateral support.

FIGURE 5B
Combination Masonry/Frame Wall
(Bearing and Non-Bearing Condition)

A-51.044 APPROVED TESTING LABORATORIES. The following laboratories have been approved by the department under s. Comm 50.19. This list is current as of the date of printing this code. Addi-

tions and deletions may occur during the effective period of this code. For information regarding the current status of a testing laboratory, call 608-266-1542.

**TABLE A 51.044
APPROVED TESTING LABORATORIES**

Name of Recognized Laboratory	ASTM STANDARD TEST						
	E-84	E-108	E-119	E-136	E-152	E-163	E-648
1. Applied Research Laboratories, Inc., Miami, FL	X	X	X	X	X	X	X
2. Commercial Testing Co., Inc., Dalton, GA	X	—	X	X	X	—	X
3. Construction Technologies, Laboratories, Skokie, IL	—	—	X	—	—	—	—
4. Factory Mutual Research Corp., Norwood, MA	X	X	X	X	X	X	X
5. Forest Product Laboratories, Madison, WI*	—	—	X	—	X	—	X
6. Hardwood Plywood Mfgs. Assoc., Reston, VA	X	—	—	—	—	—	X
7. Northwest Testing Lab., Inc., Portland, OR	—	—	X	—	X	X	—
8. Omega Point Laboratories, Inc. San Antonio, TX	X	X	X	X	X	X	X
9. PFS Corporation Madison, WI	X	—	X	—	X	—	—
10. Radco Carson, CA	X	—	—	—	—	—	—
11. Southwest Research Inst., San Antonio, TX	X	X	X	X	X	X	X
12. Underwriters Lab., Inc., Northbrook, IL	X	X	X	X	X	X	X
13. Univ. of Calif.—Berkeley, Richmond, CA	—	X	X	—	—	—	—
14. U.S. Testing Co. Fairfield, NJ	X	X	—	X	—	—	X
15. U.S. Testing Co. Los Angeles, CA	X	X	—	X	—	—	X
16. VTEC, Inc., Bronx, NY	X	X	X	X	—	—	X
17. Warnock Hersey Intl—Inc., Pittsburg, CA	X	X	X	—	X	X	—

* Reference based on research and development data. Facility is not available for conducting routine rating tests.

A-51.15 (6) EXAMPLE TO DETERMINE TOTAL AGGREGATE EXIT WIDTH.

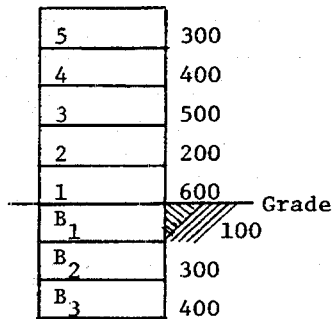

Type No. 1 sprinklered construction.

Aggregate exit width required from a floor into the stairwell is 30 inches per 100 people on that floor; i.e.,

5th floor to stairwell = $3 \times 30 = 90''$

4th floor to stairwell = $4 \times 30 = 120''$

3rd floor to stairwell = $5 \times 30 = 150''$

etc.

Total stair width required:

5th to 4th - 300 persons (100%) $\times 30''/100$ persons = 90"

4th to 3rd - [400 persons (100%) + 300 persons (50%)] $30''/100$ persons = 165"

3rd to 2nd - [500 persons (100%) + 400 persons (50%) + 300 persons (25%)] $30''/100$ persons = 232.5"

2nd to 1st - [200 persons (100%) + 500 persons (50%) + 400 persons (25%)] $30''/100$ persons = 165" (Use 232.5")

1st to exterior - [600 persons (100%) + (200 persons + 100 persons) (50%) + (500 persons + 300 persons) (25%)] $30''/100$ persons = 285"

B₁ to 1st - [100 persons (100%) + 300 persons (50%) + 400 persons (25%)] $30''/100$ persons = 105" (Use 150")

B₂ to B₁ - [300 persons (100%) + 400 persons (50%)] $30''/100$ persons = 150"

B₃ to B₂ - 400 persons (100%) $\times 30''/100$ persons = 120"

Stair width required from B1 to 1 is 150" as stair cannot decrease in width along path to exit [Comm 51.16 (2) (c)].

A-51.151 EXIT DISTRIBUTION. The following diagrams are provided to aid building designers in determining proper exit distribution:

ARRANGEMENT OF EXITS

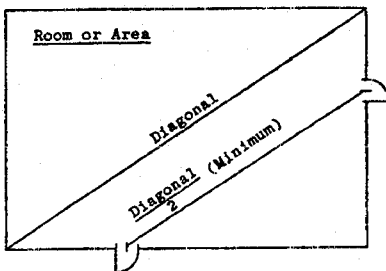

Minimum Distance = One-half of Diagonal

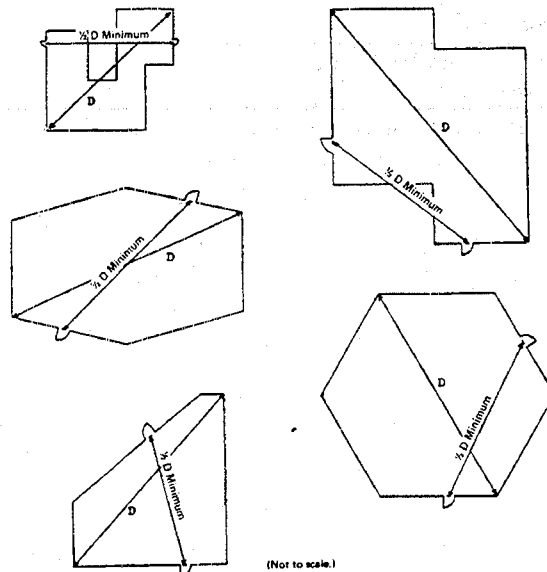

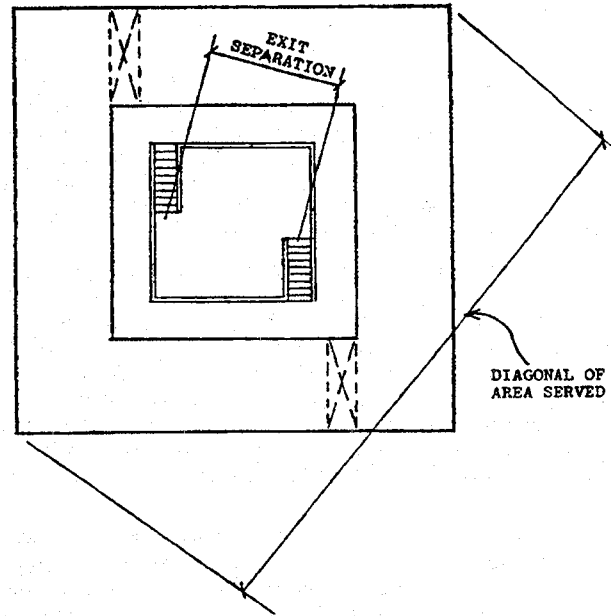
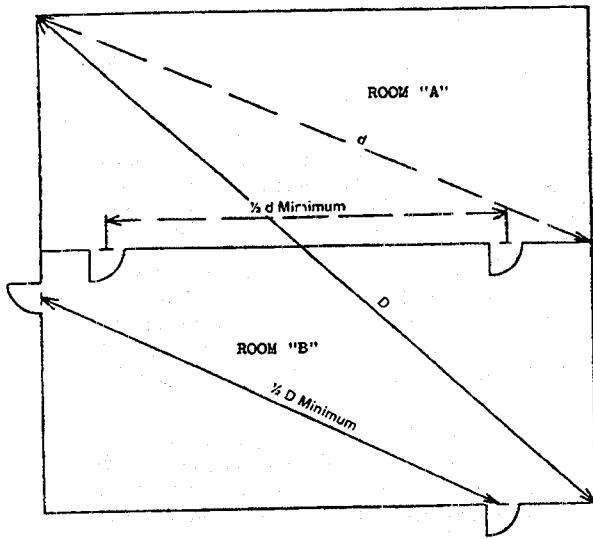

A-51.152 EGRESS CONFIGURATIONS. The following diagrams are provided to aid building designers in determining proper egress configurations:

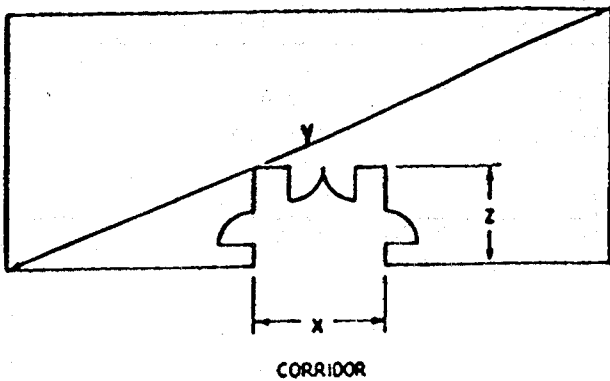

$$20' \leq x \leq \frac{y}{2}$$

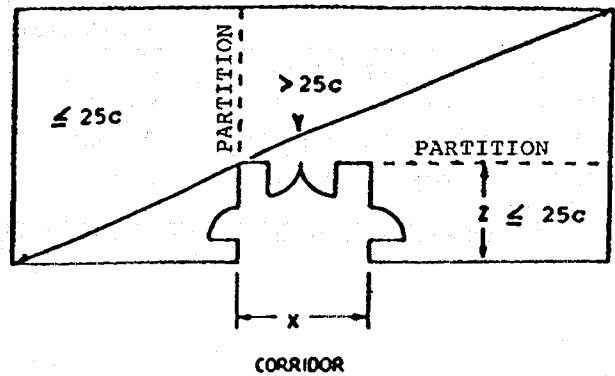

$$20' \leq x \leq \frac{y}{2}$$

A-51.22 FIRE EXTINGUISHERS. The following information is taken from the National Fire Protection Association Standard #10-1988 - Portable Fire Extinguishers. The information is provided to assist building designers in determining the number, type and location of fire extinguishers needed to comply with the provisions of the standard.

1-4 CLASSIFICATION AND RATINGS OF FIRE EXTINGUISHERS.

1-4.1 Portable fire extinguishers are classified for use on certain classes of fires and rated for relative extinguishing effectiveness at a temperature of plus 70°F by testing laboratories. This is based

upon the preceding classification of fires and the fire-extinguishment potentials as determined by fire tests.

1-4.2 The classification and rating system described in this standard is that used by Underwriters Laboratories, Inc., and Underwriters Laboratories of Canada and is based on extinguishing pre-planned fires of determined size and description as follows:

Class A Rating — Wood and excelsior.

Class B Rating — Two-inch depth n-heptane fires in square pans.

Class C Rating — No fire test. Agent must be a nonconductor of electricity.

Class D Rating — Special tests on specific combustible metal fires.

1-5 CLASSIFICATION OF HAZARDS

1-5.1 Light (low) hazard. Light hazard occupancies are locations where the total amount of Class A combustible materials, including furnishings, decorations and contents, is of minor quantity. This may include some buildings or rooms occupied as offices, classrooms, churches, assembly halls, etc. This classification anticipates that the majority of contents items are either noncombustible or so arranged that a fire is not likely to spread rapidly. Small amounts of Class B flammables used for duplicating machines, art departments, etc., are included provided that they are kept in closed containers and safely stored.

1-5.2 Ordinary (moderate) hazard. Ordinary hazard occupancies are locations where the total amount of Class A combustibles and Class B flammables are present in greater amounts than expected under light (low) hazard occupancies. These occupancies could consist of offices, classrooms, mercantile shops and allied storage, light manufacturing, research operations, auto showrooms, parking garages, workshop or support service areas of light (low) hazard occupancies and warehouses containing Class I or Class II commodities as defined by NFPA 231, Standard for General Storage.

1-5.3 Extra (high) hazard. Extra hazard occupancies are locations where the total amount of Class A combustibles and Class B flammables present, in storage, production use, and/or finished product is over and above those expected and classed as ordinary (moderate) hazards. These occupancies could consist of wood-working, vehicle repair, aircraft and boat servicing, individual product display showrooms, product convention center displays, storage and manufacturing processes such as painting, dipping,

coating, including flammable liquid handling. Also included is warehousing of, or in-process storage of other than Class I and Class II commodities.

3-2 FIRE EXTINGUISHER SIZE AND PLACEMENT FOR CLASS A HAZARDS.

3-2.1 Minimal sizes of fire extinguishers for the listed grades of hazards shall be provided on the basis of Table 3-2.1 except as modified by 3-2.3. Extinguishers shall be located so that the maximum travel distances shall not exceed those specified in Table 3-2.1, except as modified by 3-2.3.

3-2.1.1 Certain smaller extinguishers which are charged with multipurpose dry chemical or Halon 1211 are rated on Class B and Class C fires, but have insufficient effectiveness to earn the minimum 1-A rating even though they have value in extinguishing smaller Class A fires. They shall not be used to meet the requirements of 3-2.1.

3-2.2 Up to one-half of the complement of extinguishers as specified in Table 3-2.1 may be replaced by uniformly spaced 1 1/2 inch hose stations for use by the occupants of the building. When hose stations are so provided they shall conform to NFPA 14, Installation of Standpipe and Hose Systems. The location of hose stations and the placement of fire extinguishers shall be in such a manner that the hose stations do not replace more than every other extinguisher.

3-2.3 Where the floor area of a building is less than that specified in Table 3-2.1, at least one extinguisher of the minimum size recommended shall be provided.

3-2.4 The protection requirements may be fulfilled with extinguishers of higher rating provided the travel distance to such larger extinguishers shall not exceed 75 feet.

Table 3-2.1

	Light (Low) Hazard Occupancy	Ordinary (Moderate) Hazard Occupancy	Extra (High) Hazard Occupancy
Minimum rated single extinguisher	2-A	2-A	4-A*
Maximum floor area per unit of A	3,000 sq. ft.	1,500 sq. ft.	1,000 sq. ft.
Maximum floor area for extinguisher	11,250 sq. ft.	11,250 sq. ft.	11,250 sq. ft.
Maximum travel distance to extinguisher	75 ft.	75 ft.	75 ft.

*Two 2 1/2 gal water type extinguishers can be used to fulfill the requirements of one 4-A rated extinguisher.

A-52.011 HAZARD CLASSIFICATIONS. The following information is provided to assist building owners and designers in determining the hazard classifications of typical building usage or occupancy:

HAZARD CLASSIFICATION	DESCRIPTION OF FUEL LOAD	TYPICAL EXAMPLES
Low Hazard	Buildings or structures used for the manufacture or storage of noncombustible or low hazard materials, that do not ordinarily burn rapidly, such as but not limited to: asbestos; chalk; non-alcoholic beverages; brick and masonry; ceramic products; gypsum; glass and metals; foods in noncombustible containers; fresh fruits and vegetables in non-plastic containers; dairy products in non-wax coated paper containers; beer or wine in metal or glass containers; electrical motors and coils; and fertilizer.	Metal fabricating and assembly; foundries; water pumping and waste water treatment plants; fertilizer storage; telephone exchanges; freezer warehouses; storage in closed front metal cabinets; storage of noncombustible or low hazard materials on wood pallets or in paper cartons without significant amounts of combustible wrappings; and similar occupancies with slight combustibles.
Moderate Hazard	Buildings and structures used for the manufacture or storage of moderate hazard materials, which are likely to burn with moderate rapidity, but which do not produce either poisonous gases, fumes or explosives, such as but not limited to: cloth, burlap and paper bags; bamboo and rattan; canvas and leather belting; baskets; books and paper in rolls or packs; boots and shoes; cardboard and cardboard boxes; clothing; cordage; furniture; furs; glue, mucilage, paste and size; linoleum; silk; soap; sugar; tobacco products; wax candles; athletic equipment; musical instruments; beverages containing more than 12% alcohol; furniture other than metal; business machines; electronics; and plastic products not classified as high hazard.	Mercantile storage and display; offices; school-rooms; auto showrooms; aircraft storage; light manufacturing; school shop areas; leather enameling or japanning operations; grain elevators with less than one million bushel bulk storage capacity; livestock shelters; fertilizer bagging operations; feed, flour and grist mills; lumber yards; motor vehicle repair shops; petroleum warehouses for storage of lubricating oils with a flash point of 200°F. or higher; photo engraving operations; public garages; stables; upholstering and mattress manufacturing; aircraft servicing; woodworking and millworking; bakeries; boatbuilding operations; food processing; condensed and powdered milk manufacturing; paper mills or products; printing or publishing; refuse incinerators; and textile mills.
High Hazard	Buildings and structures used for the storage, manufacture or processing of: highly combustible or explosive products or materials, which are likely to burn with extreme rapidity or which may produce poisonous fumes or explosions; highly corrosive, toxic or noxious alkalies, acids or other liquids or chemicals producing flame, fumes, poisonous, irritant or corrosive gases; materials producing explosive mixtures or dusts or which result in the division of matter into fine particles subject to spontaneous ignition.	Ammunition, explosive and firework manufacture; artificial flowers and synthetic leather manufacture; celluloid and celluloid products; cotton batting and waste processes; dry cleaning establishments using or storing more than 3 gallons of flammable liquids with a flash point below 100°F. or more than 60 gallons of flammable liquids with a flash point between 100°F. and 140°F.; feather renovating; fruit ripening processes; grain elevators with one million bushel or more bulk storage capacity; hydrogenation processes; match manufacture and storage; metal enameling and japanning; nitro-cellulose film exchanges and laboratories; paint and varnish manufacture; petroleum manufacture; processing of paper or cardboard in loose form; pyroxylin product storage and manufacture; smoke houses; factories or warehouses where loose combustible fibers or dust are manufactured, processed, generated or stored; handling or using flammable liquids under conditions involving possible release of flammable vapors; and fabrication facilities and research and development areas in which hazardous production materials are used.

A-52.07 (11) ACCEPTANCE OF THE ATRIUM SMOKE CONTROL SYSTEM. The following is a reprint of an approved test procedure:

Acceptance test procedure for the atrium smoke management system.

1. All testing shall be in the presence of a representative from the department.
2. All exhaust and supply-air systems shall be operationally balanced and tested. Complete air-balance reports shall be recorded on each piece of equipment, all exhaust inlets, and all supply outlets.
3. Each automatic initiating device shall be tripped to observe proper function. This test shall be performed on both normal and emergency power.
4. Each manual switch and override shall be tripped to observe proper function. This test shall be performed on both normal and emergency power.
5. All indicator lights shall display the appropriate detection and operating status.
6. Select a location on the first floor approximately 5 ft. outside the perimeter of the atrium opening. The location shall be acceptable to the department's representative.
7. Prepare three two-minute smoke bombs.
8. Ignite all three smoke bombs. When they become fully active, manually activate the atrium smoke-management system.
9. Observe and record the results.
10. After all smoke has been cleared, select an additional location on an upper level acceptable to the department's representative.

11. Prepare three more two-minute smoke bombs.

12. Ignite all three smoke bombs. When they become fully activated, again manually activate the atrium smoke-management system.

13. Observe and record the results.

14. Acceptable performance shall be movement of the smoke from the source into the atrium and out through exhaust at the top of the atrium. Smoke migration down the corridors shall be limited to no more than a light haze at a point 25 ft from the source. Furthermore, the balconies around the perimeter of the atrium shall maintain a smoke-free zone.

15. Upon the successful completion of these tests, a signed and dated copy of the department's acceptance shall be filed with the test records and a copy shall be maintained with the quarterly test log.

16. A copy of this acceptance test procedure and all plans, specifications, and calculations for the building shall be maintained with the quarterly test log.

A-52.20 Chapter Comm 16, Wisconsin State Electrical Code, Volume 2, requires the installation of standby emergency power for certain occupancies; the following is a reprint of s. Comm 16.46 (1):

(1) WHERE REQUIRED. Standby emergency power of a type recognized by NEC 700-12 (a), (b), (c) or (f) shall be provided as a source of supply for required exit lights, emergency lighting or power in occupancies where people are housed, assembled or confined with a capacity or area equal to or greater than those listed in Column B of Table 16.46.

TABLE 16.46
OCCUPANCIES REQUIRING STANDBY EMERGENCY POWER

Column A Occupancy	Column B Calculated Capacity or Area
1. Apartment buildings	50 bedrooms, including efficiency units
2. Arenas	800 square feet (Use seated space only)
3. Art galleries	20,000 square feet
4. Assembly halls such as church dining rooms and fellowship halls, dance halls, banquet halls, dining rooms, restaurants, taverns, night clubs, school and day care center multi-purpose rooms, and similar occupancies	2,000square feet
5. Assembly halls with stage	1,400 square feet
6. Auditoriums	1,400 square feet
7. Banks	30,000 square feet
8. Bowling alleys	200 persons based on 5 persons per alley plus number of spectator seats and 10 square feet per person for bar and dining areas
9. Centers for developmentally disabled	20 inmate beds
10. Children's homes	20 beds
11. Community-based residential facilities	20 beds
12. Convents	200 beds
13. Dormitories, including those used in detention schools	200beds
14. Exhibition buildings	12,000 square feet
15. Factories	30,000 square feet
16. Field houses	800 square feet (Use seated space only)
17. Gymnasiums	200 persons based on 6 square feet per person for seated space and 15 square feet per person forunseated space
18. Hospitals	20 patient beds
19. Hotels	200 rooms
20. Jails	20 inmate beds
21. Lecture halls	1,400 square feet
22. Libraries	200 persons based on 20 square feet per person for reading rooms and 100 square feet per person for balance
23. Lodge halls	200 persons based on 6 square feet per person for seated space and 15 square feet per person for unseated space
24. Motels	100 rooms
25. Museums	20,000 square feet
26. Nursing homes	20 patient beds
27. Office buildings	30,000 square feet
28. Rooming houses	200 rooms
29. Skating rinks	3,000 square feet
30. Stores	200 persons based on 30 square feet per person for first floor and 60 square feet per person for second floor and above
31. Swimming pools (indoor)	450 square feet
32. Theaters and theater lobbies	1,400 square feet (Theater and lobby must be combined in determining total area)
33. Warehouses	120,000 square feet

A-52.60 (1) WATER CLOSETS. The following is a reprint of s. Comm 84.20 (5) (m) 7. from the plumbing code:

7. A water closet may not be located closer than 15 inches from its center to any side wall, partition, vanity, or other obstruction, nor closer than 30 inches center to center, between water closets.

There shall be at least 24 inches clearance in front of a water closet to any wall, fixture or door.

A-53.11 (4) (c) Increase in roof loads. The following design provisions may be used to determine the increase in roof loads as required by this section.

ROOF SHAPES

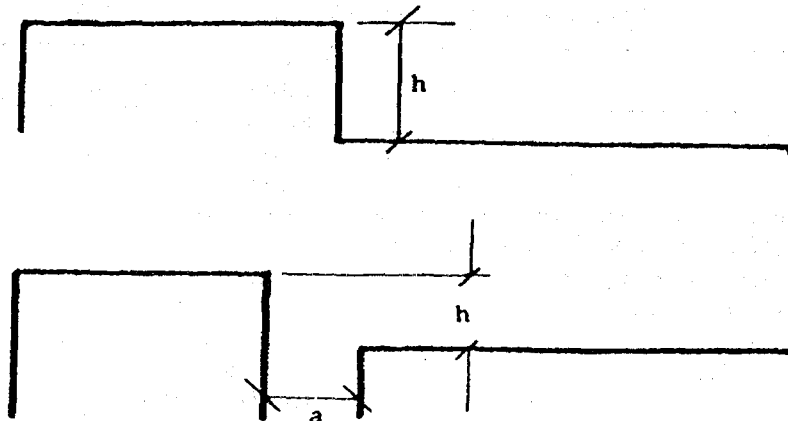

Lower level of multi-level roofs (when upper roof is part of the same building or on an adjacent building not more than 15 feet away).

SNOW LOAD DISTRIBUTIONS AND COEFFICIENTS, LIMITATIONS

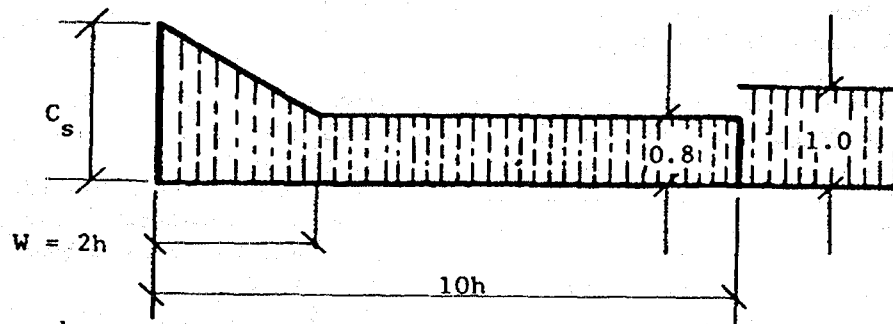

$$C_s = 15 \frac{h}{g}$$

when $15 \frac{h}{g} < 1.0$ use $C_s = 1.0$

when $15 \frac{h}{g} > 3.0$ use $C_s = 3.0^*$

$$W = 2 h$$

when $h < 5$ ft use $W = 10$

$h > 15$ ft use $W = 30$

h = difference of roof heights in ft.

g = roof live load in psf [LHR 53.11 (4)]

w = width of drift from higher building in ft.

a = distance between buildings < 15 ft.

Design upper roof for loads applicable to single-level roofs.

*An upper limit of 3 times the basic roof load has been suggested. It should be noted, however, that higher loads have been observed where an upper roof was very long (measured perpendicularly to the step between the upper and lower roofs). On the other hand, for relatively short upper roofs (say less than 50 ft), a reduction below the calculated C_s value may be judged adequate by the designer.

ROOF SHAPES

Valley areas of two-span and multi-span sloped or curved roofs

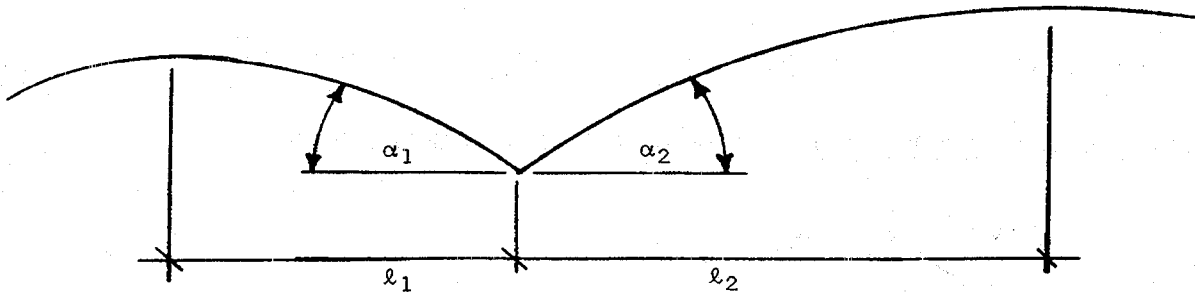
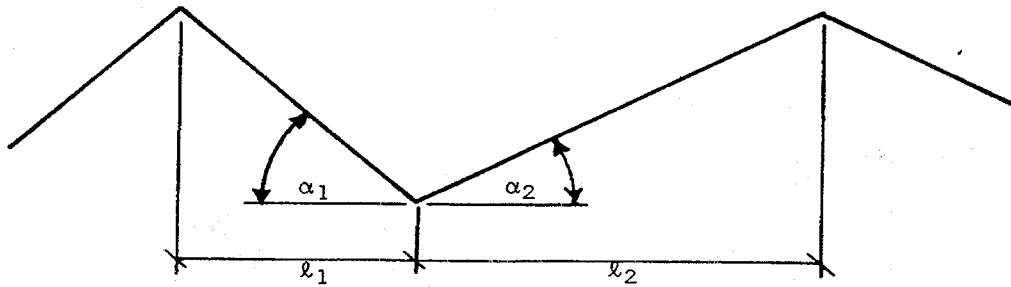

SNOW LOAD DISTRIBUTIONS AND COEFFICIENTS, LIMITATIONS

CASE I

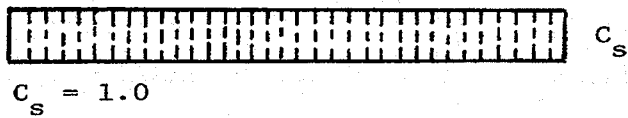

CASE II

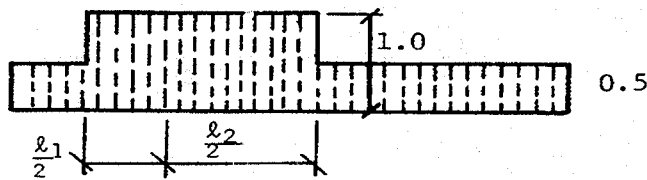

CASE III

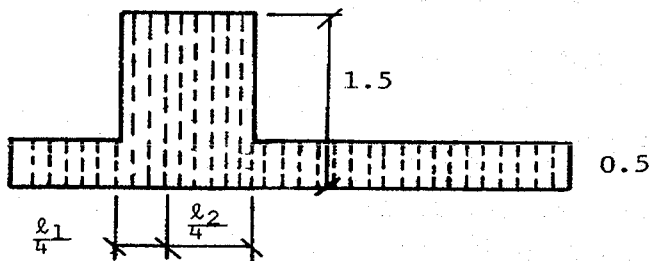

For both α_1 and $\alpha_2 \leq 10^\circ$ use Case I only; otherwise use Case I, II and III

ROOF SHAPES

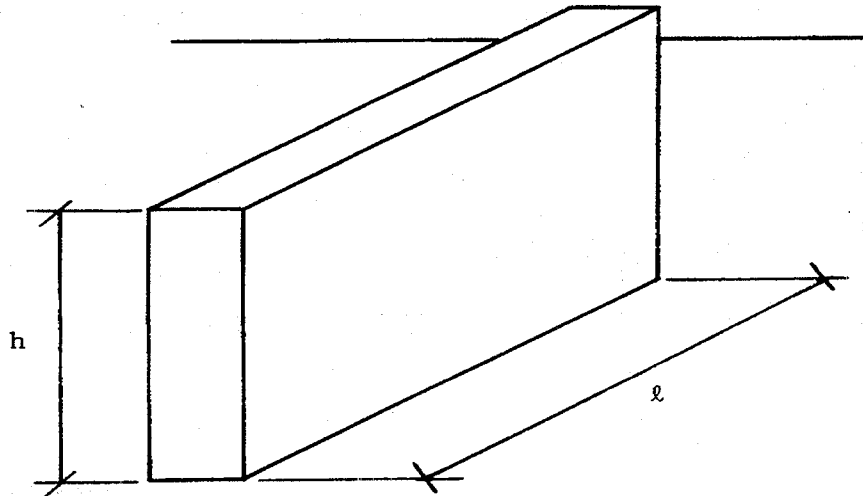

Roof areas adjacent to projections and obstructions on roofs

SNOW LOAD DISTRIBUTIONS AND COEFFICIENTS, LIMITATIONS

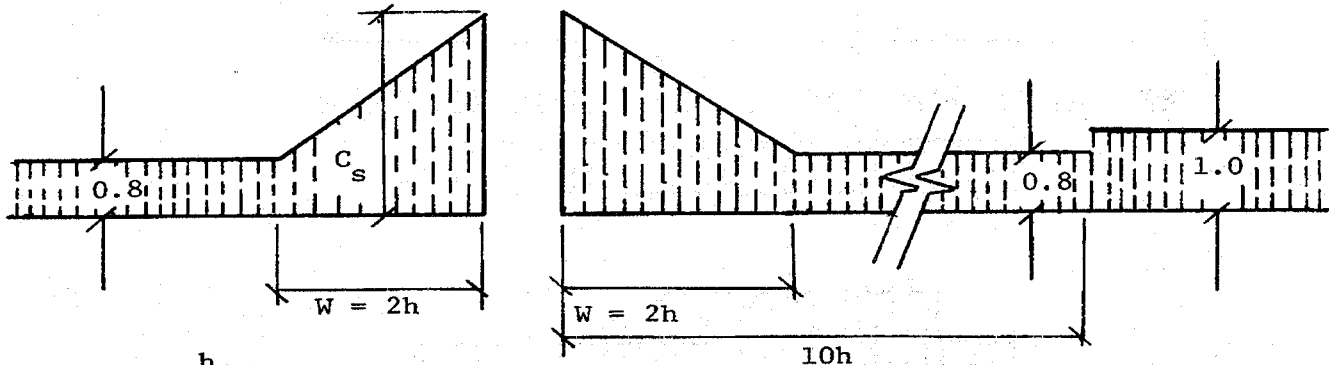

$$C_s = 10 \frac{h}{g}$$

when $10 \frac{h}{g} < 1.0$ use $C_s = 1.0$

when $10 \frac{h}{g} > 2.0$ use $C_s = 2.0$

when $l < \frac{g}{6}$ use $C_s = 1.0$

$$W = 2 h$$

when $h < 5$ ft use $W = 10$

when $h > 15$ ft use $W = 30$

h = height of projection in ft.

g = roof live load in psf

w = width of snow drift in ft.

l = length of projection in ft.

A-53.11 (4) (d) ROOF DESIGNED FOR CONTROL FLOW DRAINAGE. This section refers to the requirements of the Plumbing Code (ch. Comm 82) for storm drain sizes where control flow drainage roof design is used. The following information from the plumbing code is provided for use by the building designer:

Partial Reprint of s. Comm 82.36 (4) and (5)

(4) LOAD ON DRAIN PIPING. (a) *Storm water drainage.* The load factor on storm water drain piping shall be computed in terms of gallons per minute or on the square footage of the horizontal projection of roofs, paved areas, yards and other tributary areas.

(b) *Continuous flow devices.* Where there is a continuous or semi-continuous discharge into the storm building drain or storm building sewer, as from a pump, air conditioning unit, or similar device, each gallon per minute of such discharge shall be computed as being equivalent to 26 square feet of roof area.

(5) SELECTING SIZE OF STORM AND CLEAR WATER DRAIN PIPING. (a) *Horizontal storm water drain piping.* The pipe size for horizontal drain piping for storm water shall be determined from Tables 82.36-1 to 82.36-4.

**Table 82.36-1
MINIMUM SIZE OF STORM WATER HORIZONTAL
DRAIN PIPING ROOF AREAS**

Pipe Diameters (in inches)	Maximum Roof Areas (in square feet)			
	Pitch of Piping Per Foot			
	1/16 inch	1/8 inch	1/4 inch	1/2 inch
3	650	910	1,300	1,820
4	1,300	1,950	2,990	3,770
5	2,470	3,640	5,070	7,020
6	4,160	5,980	8,320	11,700
8	9,320	13,000	18,200	26,000
10	17,680	24,700	33,800	50,440
12	27,300	41,080	57,200	81,900
15	52,000	72,800	105,300	146,640
18	85,800	121,550	174,200	247,000
21	156,520	179,660	256,880	374,400
24	187,200	261,560	382,200	546,000

Divide square footage by 26 to obtain flow in gpm.

**Table 82.36-4
MAXIMUM CAPACITY OF STORM WATER
HORIZONTAL DRAIN PIPING FLOWING FULL**

Pipe Diameters (in inches)	Maximum Capacities in Gallons Per Minute			
	Pitch of Piping Per Foot			
	1/16 inch	1/8 inch	1/4 inch	1/2 inch
3	25	35	50	70
4	50	75	115	145
5	97	140	195	270
6	160	230	320	450
8	355	500	700	1,000
10	680	950	1,300	1,940
12	1,050	1,580	2,200	3,150
15	2,000	2,800	4,050	5,640
18	3,300	4,675	6,700	9,500
21	6,020	6,910	9,880	14,400
24	7,200	10,060	14,700	21,000

(b) *Vertical conductors for storm water.* 1. A vertical conductor for storm water shall not be smaller than the largest horizontal branch connected thereto.

2. Vertical conductors shall be sized in accordance with Table 82.36-5 or the diameter D, where

$$D = 1.128 \sqrt{\frac{A}{X}}$$

Where,

- A = the area of the roof in square feet
- X = 300 square feet per square inch for a roof covered with gravel or slag and with a pitch not exceeding 1/4 inch per foot; or
- = 250 square feet per square inch for a roof covered with gravel or slag and with a pitch of greater than 1/4 inch per foot; or
- = 200 square feet per square inch for a roof with a metal, tile, brick or slate covering and of any pitch.

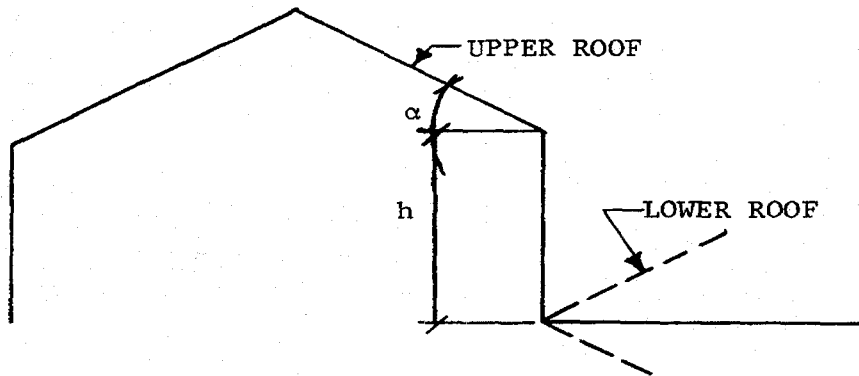

Lower of multi-level roofs with upper roof sloped towards lower roof, where α exceeds 10° .

SNOW LOAD DISTRIBUTIONS AND COEFFICIENTS, LIMITATIONS

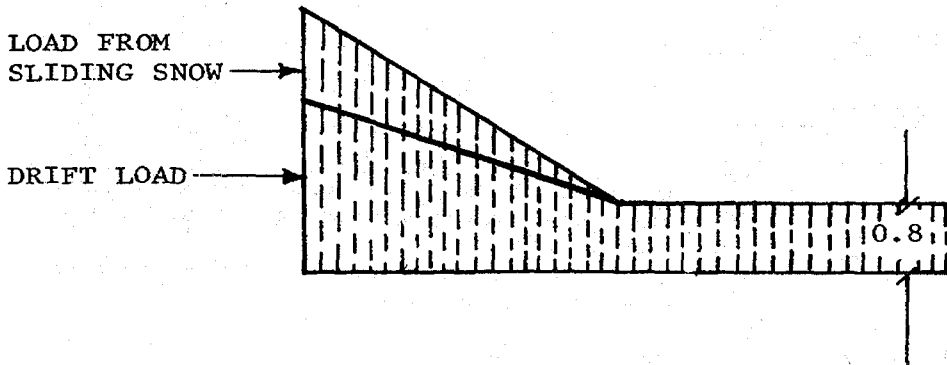

Design lower roof for loads applicable to multi-level roof plus a portion of the sliding snow from the upper roof.*

Design upper roof for loads applicable to single-level roofs.

*Where snow is likely to slide onto a lower roof from an upper roof, the lower roof should be designed for the load as provided for multi-level roofs plus an additional load produced by the snow that may slide from the upper roof. It is not possible to provide coefficients for this situation, but the following guide is recommended. Because of the remote probability that both upper and lower roofs will have their full load over the full areas simultaneously when sliding occurs, it may be assumed that the lower roof would be carrying its full load and that sliding of 50% of the total weight of the applicable uniformly distributed snow load from the upper roof would occur.

Table 82.36-5
MINIMUM DIAMETER OF VERTICAL CONDUCTORS

Type of Roof	Maximum Roof Areas (in square feet)					
	Pipe Diameters (in inches)					
	2 1/2	3	4	5	6	8
Roofs covered with gravel, slag, or similar material and with a pitch of 1/4" per foot or less.	1,645	2,120	3,780	5,885	8,490	15,125
Roofs covered with gravel, slag or similar material and with a pitch greater than 1/4" per foot.	1,220	1,770	3,150	4,905	7,075	12,600
Roofs covered with metal, tile, brick, slate or similar material and of any pitch.	975	1,415	2,520	3,925	5,660	10,080

Divide square footage by 26 to obtain flow in gpm.

A-53.15 LOAD COMBINATIONS. It is the intent of this section that the loads specified in ss. Comm 53.10 through 53.14 be considered to act in the following combinations, whichever is critical, for the design of the building frame, foundation or structural member:

1. Dead load plus live load.
2. Dead load plus wind load.
3. Dead load plus live load plus wind load.
4. Dead load plus live load plus crane loads.

Distribution of live loads which would cause the maximum shear, bending moment or stress in structural members should be investigated.

A-54.02 (4) EXIT DISTANCE. The following illustrations and text are provided to explain the procedure and intent of using the triangulation method of exit distance determination.

Exit travel must terminate at one of the following types of exits:

1. Standard exit to grade (Comm 51.15)
2. Enclosed stairways (Comm 51.17 and 51.18)
3. Horizontal exits (Comm 51.19)
4. Fire escapes (Comm 51.20)

Therefore, exit distance must be measured from one of these exit types. All exits must lead to a street, alley or open court which is connected to a street or alley.

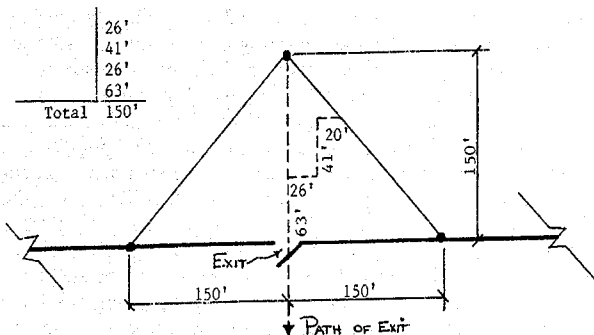

Procedure:

1. Beginning at designated exit type, measure required exit distance (150 feet, for example) at right angles to and parallel with (on both sides) the exit.
2. Connect end points to form the "exit triangle".

3. All areas within the triangle are within the required exit distance when traveling toward or at right angles to the exit.

4. All the interior space of a building must fall within the "exit triangles" formed by using the required exits for the building.

5. When measuring exit distance in stairways, only the horizontal travel distance is included in the determination.

A-54.02 (4) (c) The use of the term "high hazard" as referred to in this section is intended to apply to the following list of operations and occupancies:

1. Aircraft hangars.
2. Dry cleaning establishments: using gasoline or other volatile flammable liquids.
3. Enameling or japanning.
4. Mills: sugar, starch cereal, feed, flour and grist mills.
5. Paint and varnish: manufacturing, storing, handling, spraying, and other related operations.
6. Proxylin products: manufacture and storage.
7. Repair garages.
8. Smoke houses.
9. Storage of: explosive gases under pressure (15 psi and over 2500 cubic feet) such as acetylene, hydrogen, natural gas, etc.
10. Storage of: materials with a flash point under 200° F. such as celluloid products, kerosene, oils, etc.
11. Woodworking establishments.

A-57.02 (2) (b) VERTICAL DIVISION WALLS. See drawings and illustrations in s. A 51.03 (5) (a) for typical floor/ceiling-wall connection details for vertical division walls. Disregard masonry components shown in drawings when masonry is not used in the construction of the vertical division wall.

A-57.07 (3) CHANGES OF ELEVATION WITHIN INDIVIDUAL LIVING UNITS. Section Comm 57.07 (3) permits the steps, stairs and ramps within individual living units to conform with s. Comm 21.04 of the Uniform Dwelling Code. The following is a reprint of the applicable portions of that section:

Comm 21.04 Stairs. Every exterior or interior stairs, except those leading to attics or crawl space or similar non-habitable spaces, shall conform to the requirements of this section.

(1) LANDINGS. (a) *Intermediate landings.* Intermediate landings located in a flight of stairs shall be at least as wide as the stairs and shall measure at least 3 feet in the direction of travel. Trim and handrails may project no more than 3 1/2 inches into the required width.

(b) *Landings at the top and base of stairs.* A level landing shall be provided at the top and at the foot of every stairs. The landing

shall be at least as wide as the stairs and shall measure at least 3 feet in the direction of travel.

(c) *Doors at landings.* Except as provided in subds. 1 to 4, level landings shall be provided on each side of any door located at the foot or head of a stairway, regardless of the door swing. In the application of the exceptions given in subds. 1 to 4, stairways to attached garages or porches are considered to be interior stairways.

1. Exception. A landing shall not be required between the door and the head of interior stairs, provided the door does not swing over the stairs.

2. Exception. A landing shall not be required between the door and the head of an interior stairway of 2 or fewer risers, regardless of doorswing.

3. Exception. A landing shall not be required between a sliding glass door and the head of an exterior stairway of 3 or fewer risers.

4. Exception. The exterior landing, platform or sidewalk at an exterior doorway shall be located not more than 8 inches below the interior floor elevation. The landing platform shall have a length at least equal to the width of the door.

(2) **HANDRAILS AND GUARDRAILS.** (a) *Handrails.* Every stairs of more than 3 risers shall be provided with at least one handrail. Handrails shall be provided on all open sides of stairways.

(b) *Guardrails.* All openings between floors, open sides of landings, platforms, balconies or porches which are more than 24 inches above grade or a floor, shall be protected with guardrails.

(c) *Handrail and guardrail details.* 1. Height. Handrails shall be located at least 30 inches, but not more than 34 inches, above the nosing of the treads. Guardrails shall be located at least 36 inches above the upper surface of the floor.

2. Open railings. Open guardrails or handrails shall be provided with intermediate rails or an ornamental pattern to prevent the passage of a sphere with a diameter larger than 9 inches.

3. Clearance. The clearance between the handrail and the wall surface shall be at least 1¹/₂ inches.

4. Loading. Handrails and guardrails shall be designed and constructed to withstand a 200 pound load applied in any direction.

5. Exterior rails. Exterior handrails and guardrails shall be constructed of metal, decay resistant or pressure treated wood or shall be protected from the weather.

(3) **STAIR DETAILS.** Stairs shall meet the following requirements:

(a) *Minimum width.* Every stairs shall measure at least 3 feet in width.

(b) *Headroom.* Every stairs shall be provided with a minimum headroom clearance of 6 feet 4 inches. The minimum clearance shall be measured vertically from a line parallel to the nosing of the treads to the ceiling or soffit directly above that line.

(c) *Treads and risers.* Risers shall not exceed 8 inches in height, measured vertically from tread to tread. Treads shall be at least 9 inches wide, measured horizontally from nosing to nosing. There shall be no variation in uniformity exceeding ³/₁₆ inch in the width of tread or in the height of risers. No flight of stairs shall exceed 12 feet in height unless landings are provided.

(d) *Winders.* Winder steps may be used in stairs where the length of the tread is at least 3 feet and the winder tread measures at least 7 inches in width from nosing to nosing at a point one foot from the narrow end of the tread.

(e) *Spiral stairs.* Spiral stairs may be used as an exit stairs. The tread shall measure at least 26 inches from the outer edge of the supporting column to the inner edge of the handrail and at least 7

inches in width from nosing to nosing at a point one foot from the narrow end of the tread.

A-57.11 The intent of this section is to apply to floor levels not more than one story below grade (at building).

A-57.11 (1) (f) It is the intent of this subsection that each living unit needs only one means of exit from within the unit and that the entire building be provided with no less than 2 exits.

A-57.81 Requirement 1. (4) SITE IMPRACTICALITY GUIDELINES.

(2) Site impracticality. Covered multifamily dwellings with elevators shall be designed and constructed to provide at least one accessible entrance on an accessible route, regardless of terrain or unusual characteristics of the site. Covered multifamily dwellings without elevators shall be designed and constructed to provide at least one accessible entrance on an accessible route unless terrain or unusual characteristics of the site are such that the following conditions are found to exist:

(a) Site impracticality due to terrain. There are two alternative tests for determining site impracticality due to terrain: the individual building test provided in paragraph (i), or the site analysis test provided in paragraph (ii). These tests may be used as follows.

A site with a single building having a common entrance for all units may be analyzed only as described in paragraph (i).

All other sites, including a site with a single building having multiple entrances serving either individual dwelling units or clusters of dwelling units, may be analyzed using the methodology in either paragraph (i) or paragraph (ii). For these sites for which either test is applicable, regardless of which test is selected, at least 20% of the total ground floor units in nonelevator buildings, on any site, must comply with the guidelines.

(i) Individual building test. It is impractical to provide an accessible entrance served by an accessible route when the terrain of the site is such that:

(A) the slopes of the undisturbed site measured between the planned entrance and all vehicular or pedestrian arrival points within 50 feet of the planned entrance exceed 10 percent; and

(B) the slopes of the planned finished grade measured between the entrance and all vehicular or pedestrian arrival points within 50 feet of the planned entrance also exceed 10 percent.

If there are no vehicular or pedestrian arrival points within 50 feet of the planned entrance, the slope for the purposes of this paragraph (i) will be measured to the closest vehicular or pedestrian arrival point.

For purposes of these guidelines, vehicular or pedestrian arrival points include public or resident parking areas; public transportation stops; passenger loading zones; and public streets or sidewalks. To determine site impracticality, the slope would be measured at ground level from the point of the planned entrance on a straight line to (i) each vehicular or pedestrian arrival point that is within 50 feet of the planned entrance, or (ii) if there are no vehicular or pedestrian arrival points within that specified area, the vehicular or pedestrian arrival point closest to the planned entrance. In the case of sidewalks, the closest point to the entrance will be where a public sidewalk entering the site intersects with the sidewalk to the entrance. In the case of resident parking areas, the closest point to the planned entrance will be measured from the entry point to the parking area that is located closest to the planned entrance.

(ii) Site analysis test. Alternatively, for a site having multiple buildings, or a site with a single building with multiple entrances, impracticality of providing an accessible entrance served by an accessible route can be established by the following steps:

(A) The percentage of the total buildable area of the undisturbed site with a natural grade less than 10% slope shall be calculated. The analysis of the existing slope (before grading) shall be done

on a topographic survey with two foot (2') contour intervals with slope determination made between each successive interval. The accuracy of the slope analysis shall be certified by a professional licensed engineer, landscape architect, architect or surveyor.

(B) To determine the practicality of providing accessibility to planned multifamily dwellings based on the topography of the existing natural terrain, the minimum percentage of ground floor units to be made accessible should equal the percentage of the total buildable area (not including floodplains, wetlands, or other restricted use areas) of the undisturbed site that has an existing natural grade of less than 10% slope.

(C) In addition to the percentage established in paragraph (B), all ground floor units in a building, or ground floor units served by a particular entrance, shall be made accessible if the entrance to the units is on an accessible route, defined as a walkway with a slope between the planned entrance and a pedestrian or vehicular arrival point that is no greater than 8.33%.

(b) Site impracticality due to unusual characteristics. Unusual characteristics include sites located in a federally-designed floodplain or coastal high-hazard area and sites subject to other similar requirements of law or code that the lowest floor or the lowest structural member of the lowest floor must be raised to a specified level at or above the base flood elevation. An accessible route to a building entrance is impractical due to unusual characteristics of the site when:

(i) the unusual site characteristics result in a difference in finished grade elevation exceeding 30 inches and 10 percent measured between an entrance and all vehicular or pedestrian arrival points within 50 feet of the planned entrance; or

(ii) if there are no vehicular or pedestrian arrival points within 50 feet of the planned entrance, the unusual characteristics result in a difference in finished grade elevation exceeding 30 inches and 10 percent measured between an entrance and the closest vehicular or pedestrian arrival point.

A-57.85 REACH DIMENSIONS OVER AN OBSTRUCTION.

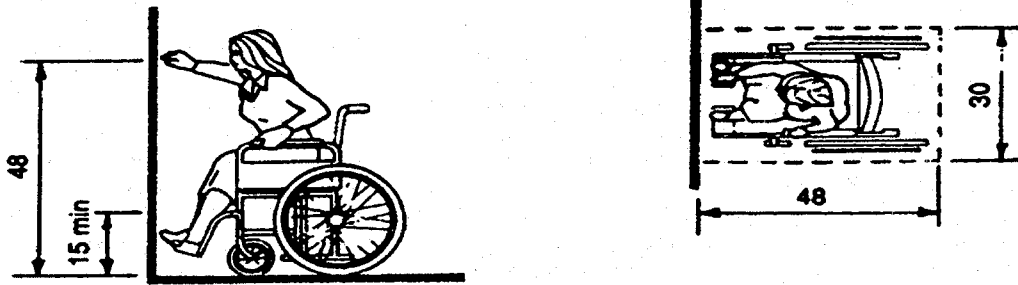

(a) Forward Reach Limit

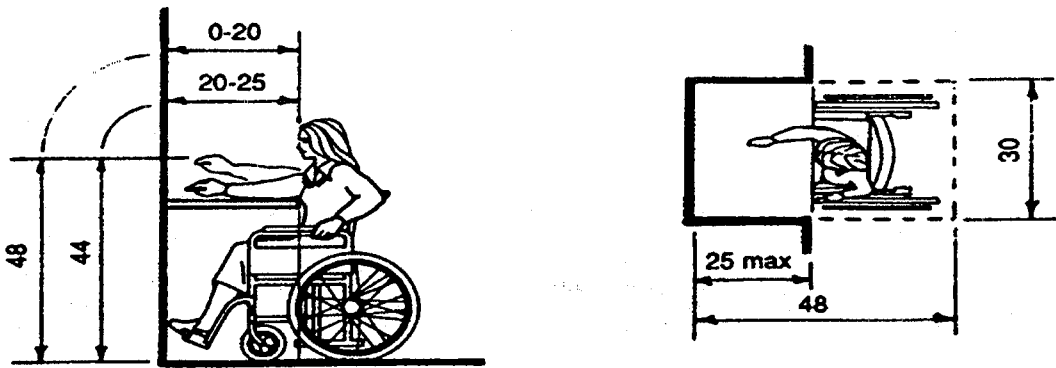

NOTE: Clear knee space should be as deep as the reach distance.

(b) Maximum Forward Reach Over an Obstruction

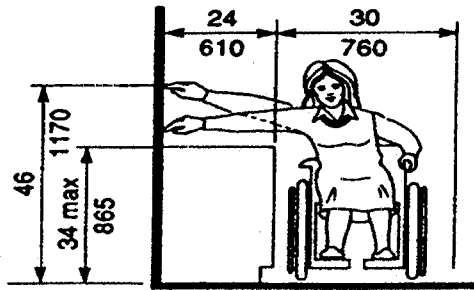

(c) Maximum Side Reach Over Obstruction

A-57.87 Usable kitchens. MINIMUM CLEAR FLOOR SPACE FOR WHEELCHAIRS.

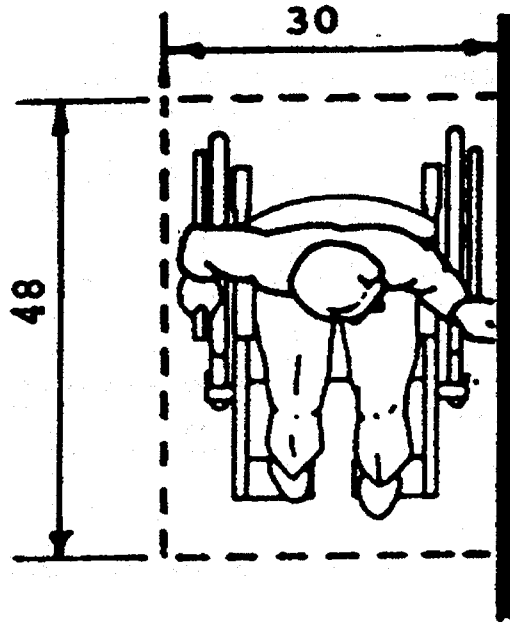

(a) Parallel Approach

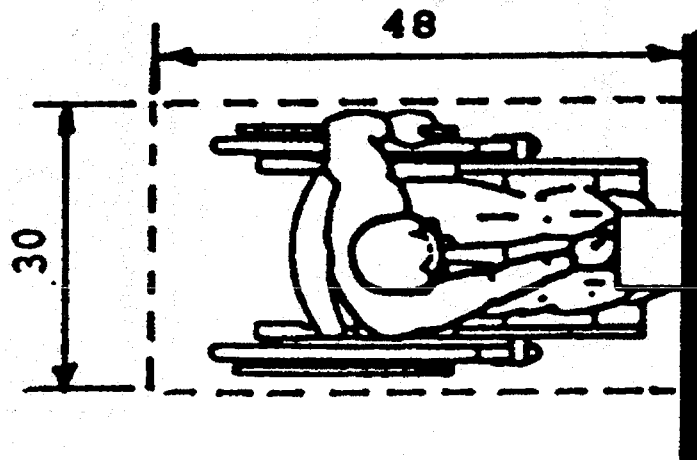

(b) Forward Approach

A-57.871 (1) BASIC USABILITY AND 57.871 (2) HIGHER LEVEL OF USABILITY: CLEAR FLOOR SPACE FOR WATER CLOSETS.

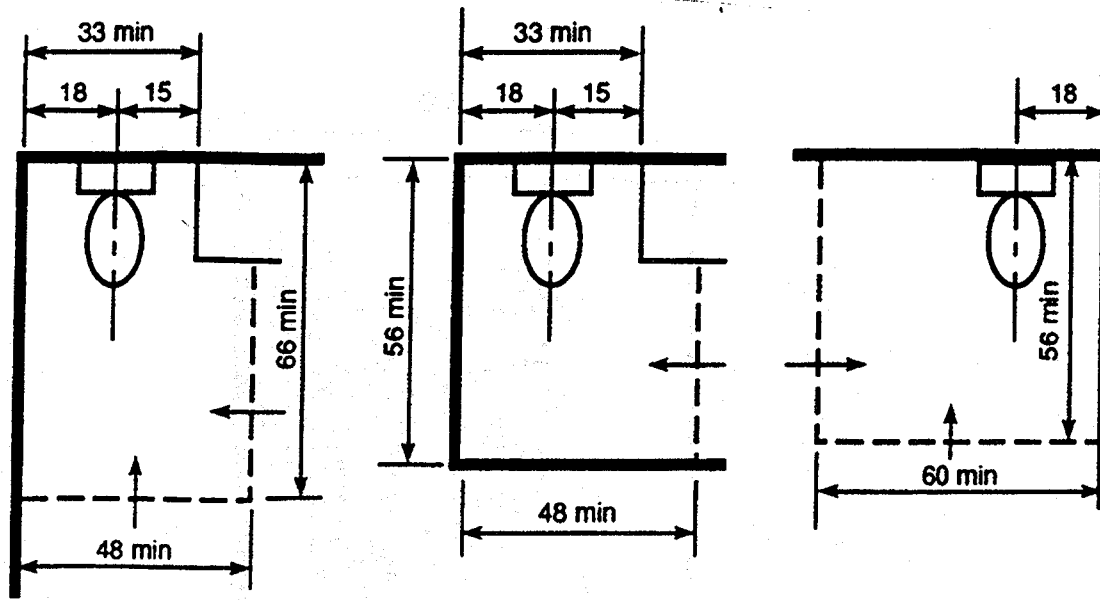

Clear Floor Space for Water Closets

A-57.871 (1) BASIC USABILITY: CLEAR FLOOR SPACE AT BATHTUBS.

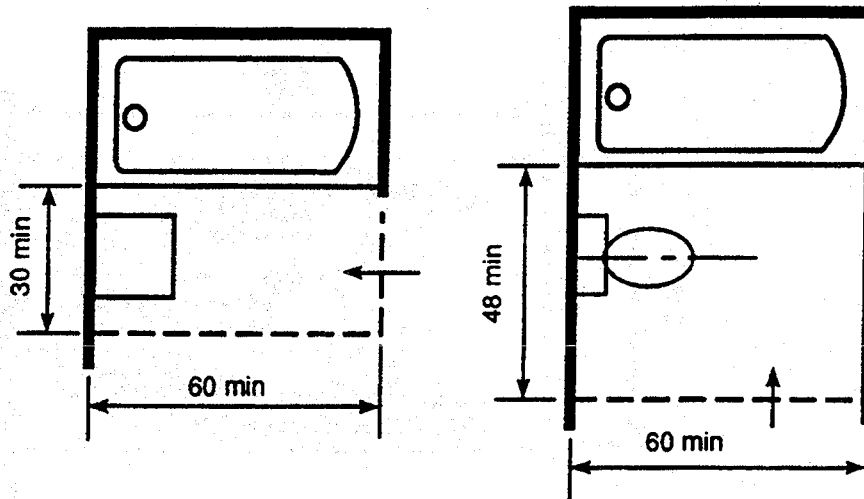

Clear Floor Space at Bathtubs

A-57.871 (1) BASIC USABILITY AND 57.871 (2) HIGHER LEVEL OF USABILITY: CLEAR FLOOR SPACE AT LAVATORIES.

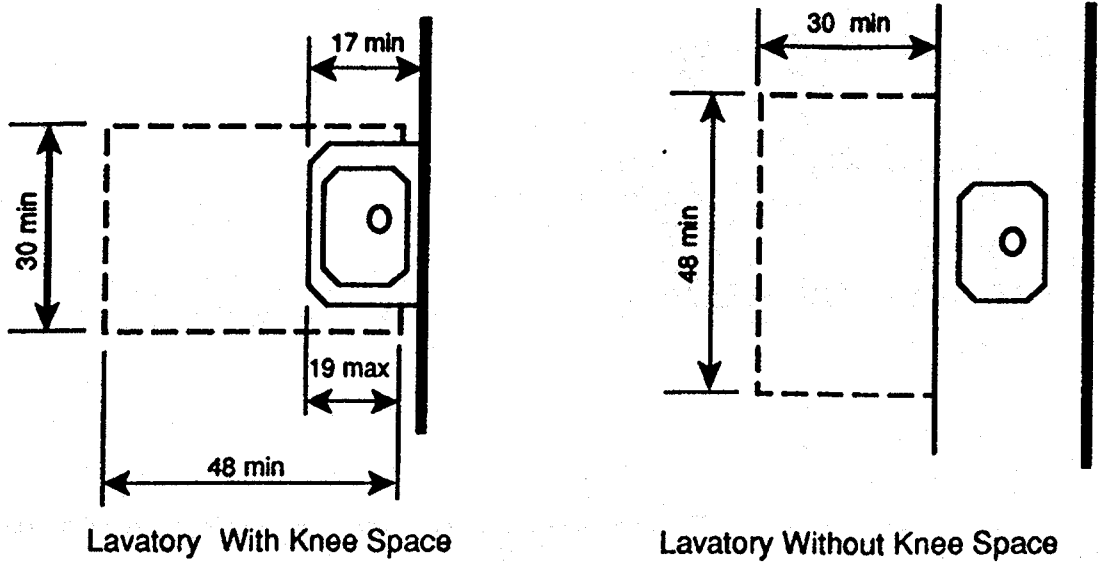

Lavatory With Knee Space

Lavatory Without Knee Space

Clear Floor Space at Lavatories

A 57.871 (1) BASIC USABILITY AND 57.871 (2) HIGHER USABILITY: CLEAR FLOOR SPACE AT SHOWERS.

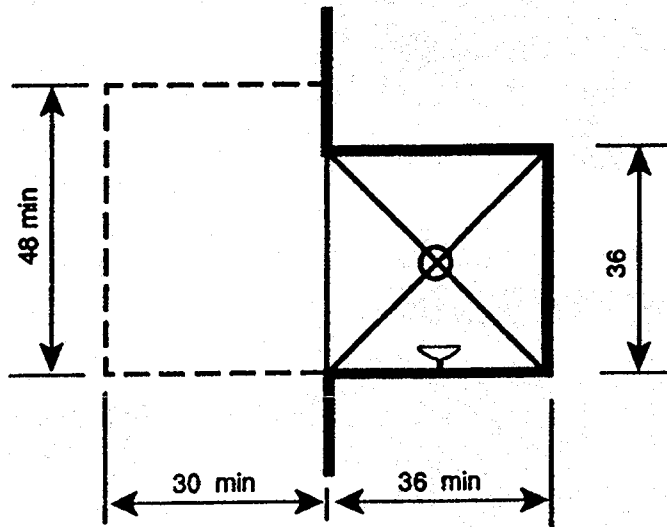

Clear Floor Space at Shower

A-57.871 (1) BASIC USABILITY: EXAMPLE OF A COMPLETE BATHROOM COMPLYING WITH BASIC USABILITY.

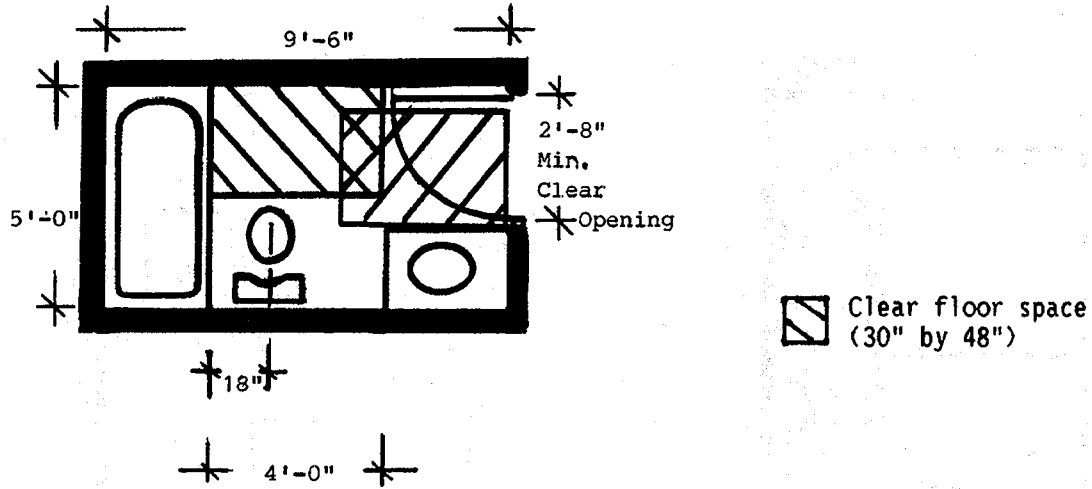

A-57.871 (2) HIGHER LEVEL OF USABILITY: EXAMPLES OF COMPLETE BATHROOMS COMPLYING WITH THE HIGHER LEVEL OF USABILITY.

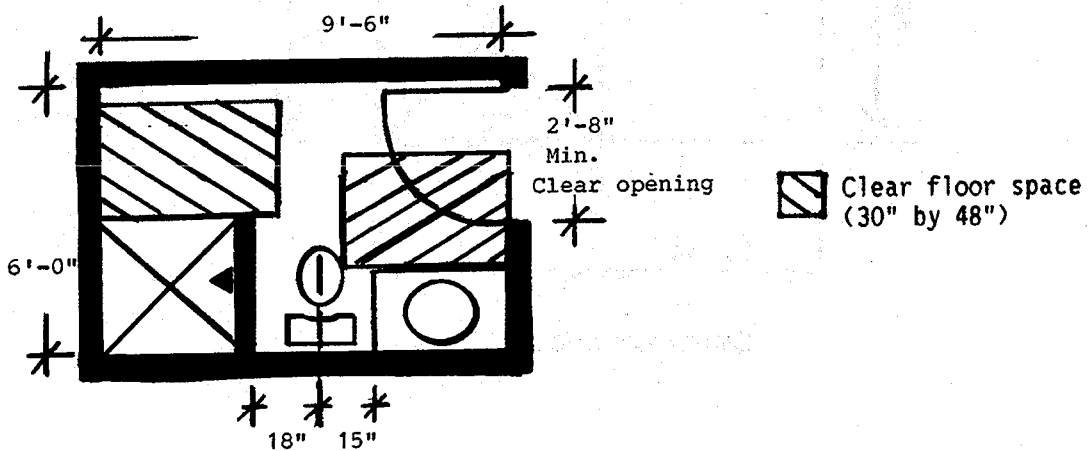
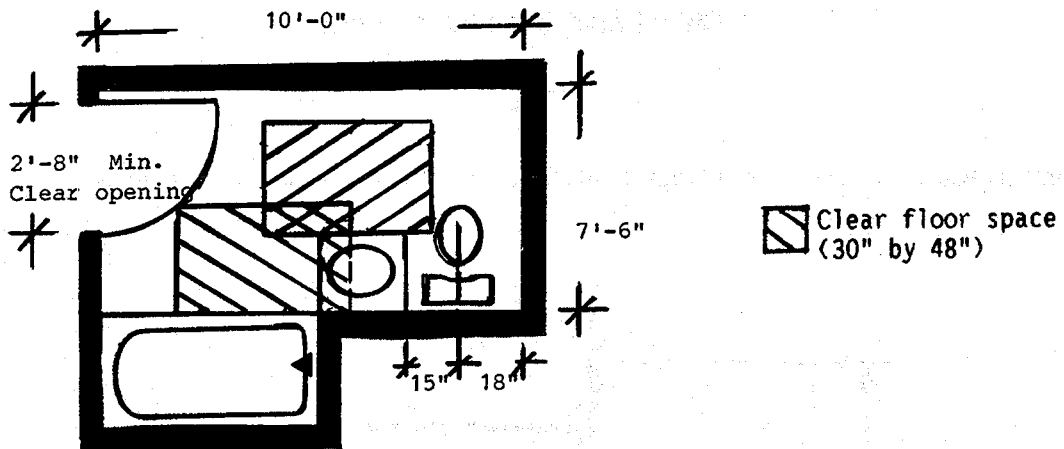

A-57.871 (2) HIGHER LEVEL OF USABILITY: EXAMPLES OF COMPLETE BATHROOMS COMPLYING WITH THE HIGHER LEVEL OF USABILITY.

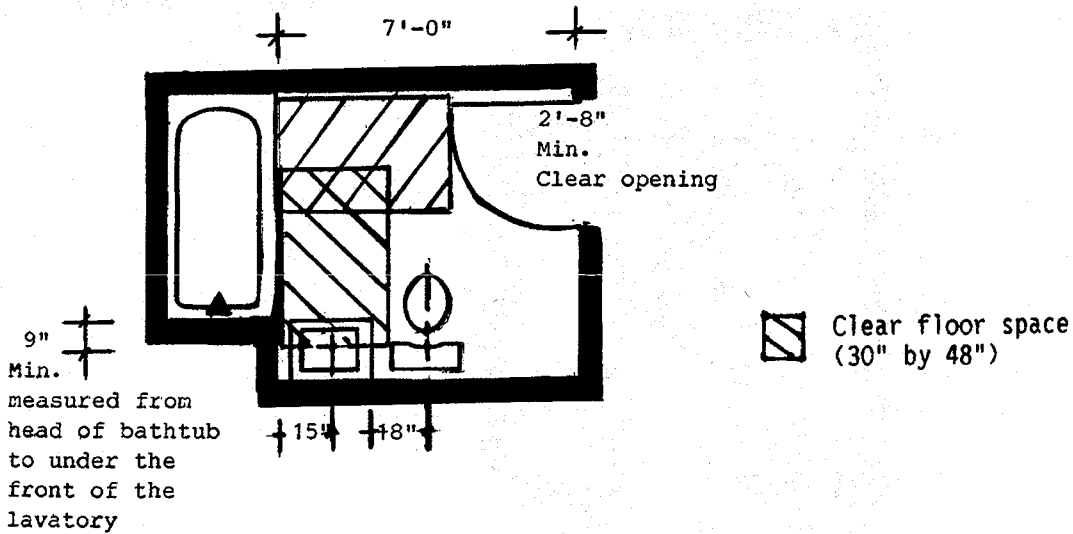
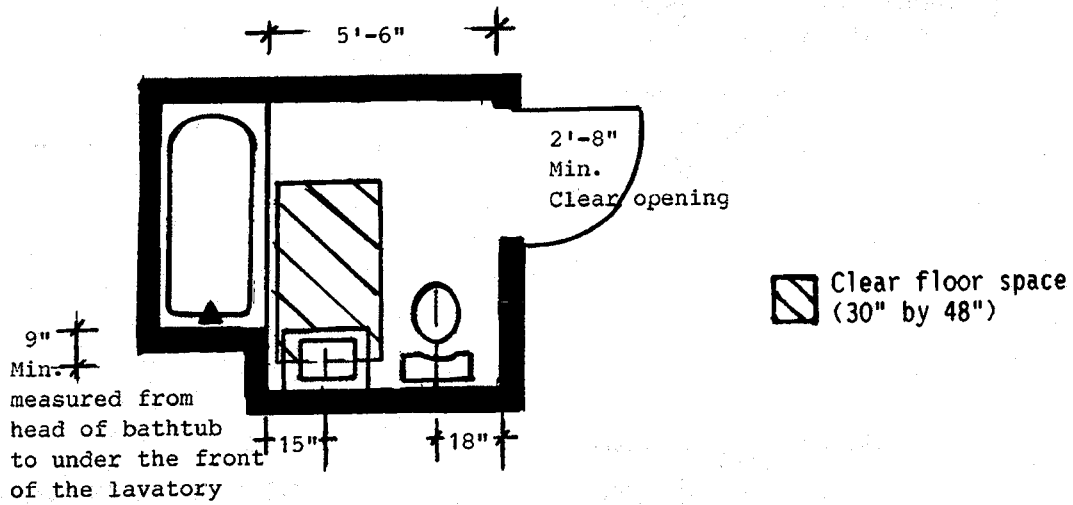
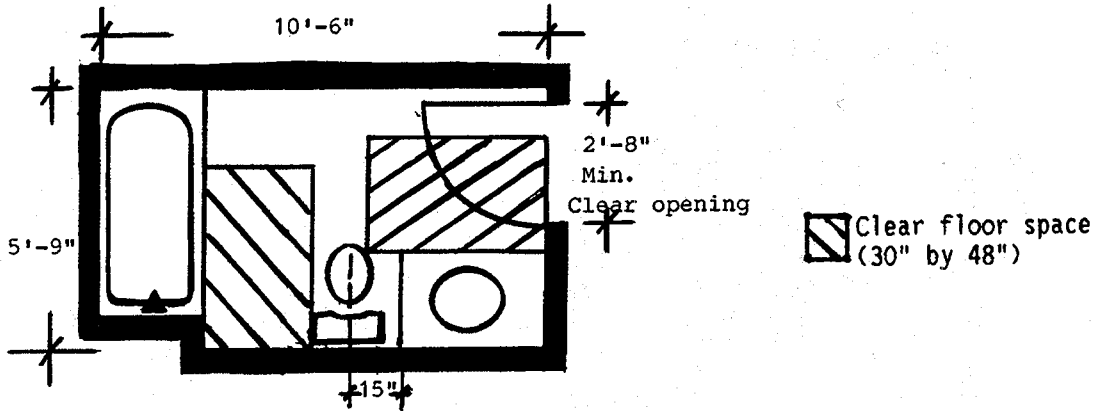

A-57.871 (2) HIGHER LEVEL OF USABILITY: EXAMPLES OF COMPLETE BATHROOM COMPLYING WITH THE HIGHER DEGREE OF USABILITY.

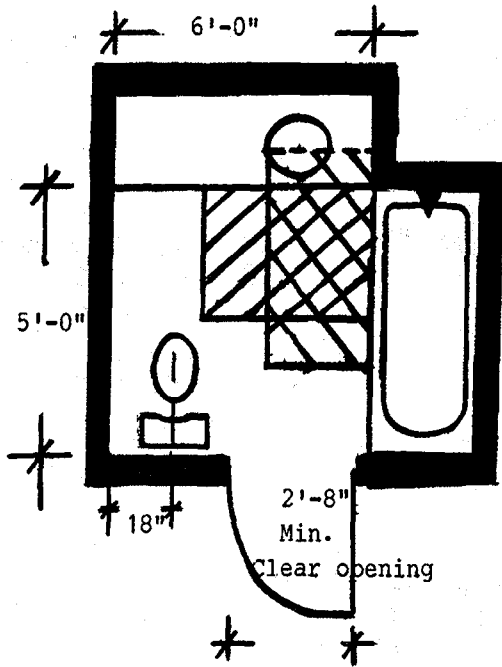

 Clear floor space (30" by 48")

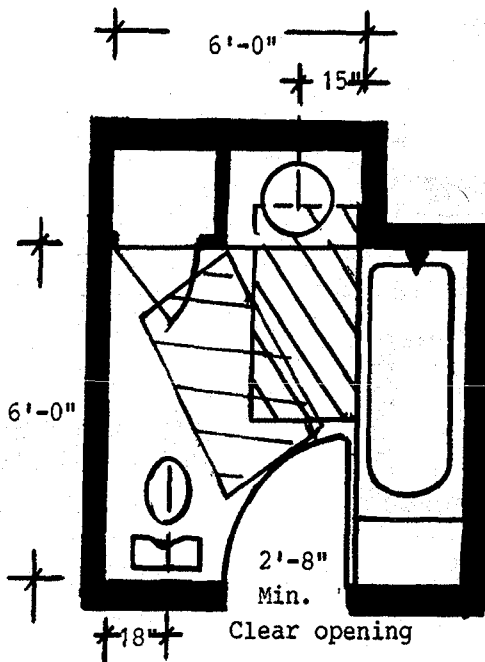

 Clear floor space (30" by 48")

A-57.871 (3) POWDER ROOMS: EXAMPLES OF ADAPTABLE POWDER ROOMS.

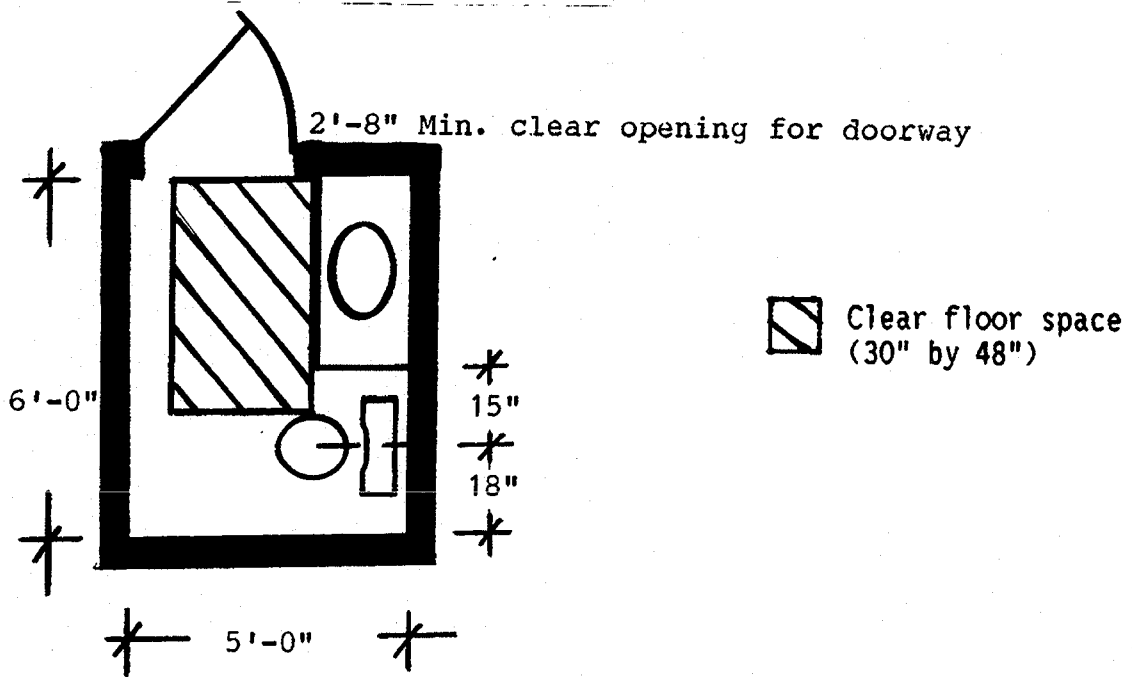
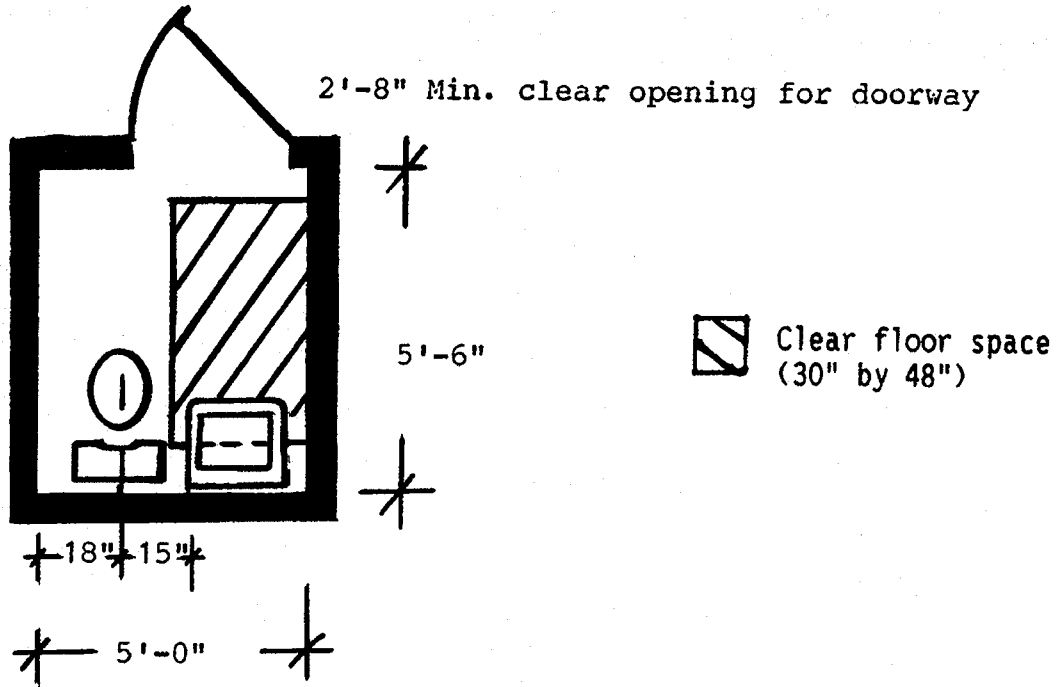

A-59.14 (2) (c) EXIT DISTANCE. See the information and illustration contained in A-54.02 (4).

A-60.19 (4) The standard is available from the National Fire Protection Association, Batterymarch Park, Quincy, Massachusetts 02269.

A-60.35 Class A fires are fires in ordinary combustible materials such as wood, cloth, paper, rubber, and many plastics. Class B fires are fires in flammable liquids, gases and greases.

A-60.36 (1) (a) See A-60.19 (4).

A-62.25 (1) CLEARANCE LIMITATIONS. The intent is to require the minimum 7 feet 0 inches clearance only in traffic lanes and in all areas normally used by the public to leave from and return to their vehicles.

A-62.50 FIRE EXTINGUISHERS. See A-51.22 for related information.



CHAPTERS COMM 63 & 64 PLAN CHECK WORKSHEETS

SECTION I. ENERGY/HVAC FORM INDEX

SECTION II. BUILDING ENVELOPE

SECTION III. LIGHTING

SECTION IV. HVAC

The following worksheets, or equivalent information, is required to be submitted with each project. See Comm Ch. 63 and 64 for details.

INDEX **I-6**



Transaction ID#	Submitter's Name		
Owner's Name	Date		
Building Location (Number & Street)	City	Village	Township of

All constructions or installations under s. Comm 50.07 (2) and (3) shall be supervised by a Wisconsin registered architect or engineer, except that a Wisconsin registered HVAC designer may supervise the installation of heating, ventilating and air conditioning systems, and a registered electrical designer may supervise the installation of illumination systems. The plans, specifications, and calculations require the signature and seal or stamp of the appropriate professional listed above. Comm 50.08.

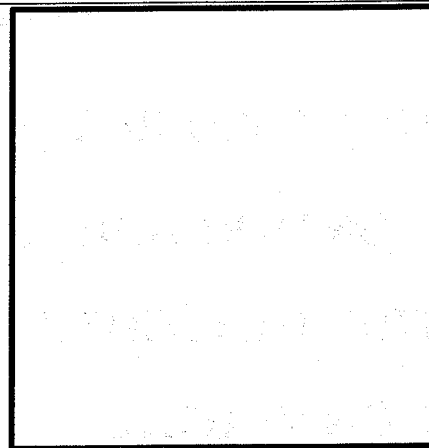

Registration Stamp & Signature

ENERGY EFFICIENCY PLAN CHECK WORKSHEETS

I. ENERGY/HVAC FORM INDEX

Check below if included with submittal

I-1: Index

II. BUILDING ENVELOPE PLAN CHECK WORKSHEETS

E-1: Building Envelope Summary

E-2: Fenestration Worksheet

E-3: Opaque Surfaces Worksheet

E-4: Skylight Exemption Worksheet

E-5: Opaque Trade-Off Worksheet

III. LIGHTING PLAN CHECK WORKSHEETS

L-1: Lighting Summary

L-2: Exterior Lighting Power Worksheet

L-3: Installed Interior Lighting Power Worksheet

L-4: Complete Building/Area Category Methods Worksheet

L-5: Activity Method Worksheet

IV. HVAC PLAN CHECK WORKSHEETS

H-1: HVAC Summary

H-2: HVAC Prescriptive Worksheet

H-3: HVAC Equipment Summary

The information you provide may be used by other agency programs [Privacy Law, s. 15.04 (1)(m)].

SBD-10512 (R. 10/98)

II. BUILDING ENVELOPE PLAN CHECK DOCUMENTS

This section describes the forms and procedures for documenting compliance with the building envelope energy efficiency requirements of the code. It does not describe the details of the requirements; these are presented in the code. Determination of code compliance will be based on the actual code section. The following discussion is addressed to the designer preparing construction documents and compliance statements and to the plan reviewers who are examining those documents for compliance with the code.

The use of each form is briefly described below. The complete instructions for each form are presented in the following subsections.

E-Building Envelope Summary.

This information is required for every project involving the building envelope.

E-Fenestration Worksheet.

Used only for the Component Standards and System Standards methods. This worksheet produces area-weighted average values for the Fenestration U-Value and Shading Coefficient (SC_x). For the System Standards method of s. Comm 63.16, one of these worksheets should be completed for each orientation. (It is not necessary to fill this out if there is only one Fenestration U-Value and Shading Coefficient for the entire project.)

E-~~O~~paque Surfaces Worksheet.

This worksheet is used only for the Component Standards method and System Standards method. This worksheet produces the area-weighted average values for the U-values of roof, walls (including opaque doors), and floor assemblies. For the System Standards method, one of these worksheets should be completed for each orientation.

E-~~S~~kylight Exemption Worksheet.

This information will only be required when skylights are to be exempt from the roof area thermal performance calculation.

E-~~O~~paque Trade-Off Worksheet.

This information will only be required when opaque trade-offs are used per the requirements of Comm 63.15 (3) & (4).

SBD-10373 (R.10/98)

BUILDING ENVELOPE SUMMARY E-1

This worksheet is applicable to all projects involving the building envelope.

Project Information

This information asks for the project name and address and those people responsible for the building design and compliance forms.

Compliance Approach

Check one of the three boxes:

- Component Standards:** If this box is checked, provide the number of the region in which the building is located from Figure 63.15-2 of the code and the Alternate Component Package (ACP) Table letter.
- System Standards:** If this box is checked, provide the computer printout or other documentation of envelope compliance and E-1 form, or appropriate thermal performance calculations for factories and warehouses as listed in Comm 63.14 (2)(3).
- System Analysis Design:** If the project is demonstrating compliance through the System Analysis Design method, check this box. A complete analysis must be provided.

Basic Requirements

Fill the boxes in this column with either a check mark or "X" to indicate a positive response or "N/A" to indicate a negative response. If the skylight exemption is marked (see "Special Considerations"), attach the Skylight Exemption Worksheet (E-4).

Prescriptive/Performance Requirements

If the project is demonstrating compliance through the Component Standards method, all of these items must be completed. The area-weighted properties such as components U-values and fenestration SC_x are obtained from the Fenestration Worksheet (E-2) and Opaque Surfaces Worksheet (E-3). The items under "Requirements" are obtained from the ACP Table.

If the System Standards method is used (e.g., ASHRAE's ENVSTD Program), only the items in the "Design" column need to be completed. Where there is more than one of a particular assembly, enter all of the values.

If the Opaque Trade-Off is used, provide the design information and demonstrate that the Total Design $U \cdot \text{Area}$ is equal to or less than the Total Required $U \cdot \text{Area}$.

If the System Analysis Design method (e.g., ASHRAE's Energy Cost Budget method) is used, the items in the design column should be filled in, where applicable, to speed the plan review.

Additional Data

This column serves as a reference for additional building envelope forms and calculations. If Worksheets E-2 through E-5 are submitted, it should be indicated on Form I-1. Boxes are provided for other submittal data. An additional blank is provided to indicate attached calculations such as calculation of mass wall heat capacity or interpolations of tables.

FENESTRATION WORKSHEET E-2

This worksheet is applicable to projects that demonstrate compliance through the Component Standards method or the System Standards method. It is not applicable to projects that demonstrate compliance through the System Analysis Design method.

Project Information

A box for basic project information and identification of the document author is provided in the upper part of this form. This should match the information contained in the Basic Project Information section of the Building Envelope Summary (E-1) form.

Area-Weighted Properties

- | | |
|---|--|
| Assembly ID: | Insert a descriptor of the particular assembly. A separate ID must be supplied for each group of assemblies that have unique U-values or shading coefficients. |
| Area: | Enter the Total Area (in ft ²) for that fenestration assembly (glazing and frame) on a project-wide basis. For the System Standards method, this would be the area for that assembly on an orientation basis. The values from all entries in this column should be summed into the box marked "Total Area" at the bottom of the column. |
| U-Value (or shading coefficient, SC _x): | Enter the appropriate property for each fenestration assembly (glazing and frame). |
| U (or SC _x) • Area: | This column is the product of the assembly area (second column) by the fenestration U-value (or SC _x from the third column). The values from all entries in this column should be summed into the box marked "Total U•Area" at the bottom of the column.

The area-weighted U-value (or SC _x) is calculated by dividing the value in "Total U•Area" by the value in "Total Area." |

OPAQUE SURFACES WORKSHEET E-3

This worksheet is applicable to projects that demonstrate compliance through either the Component Standards method or System Standards method. It is not applicable to projects that demonstrate compliance through the System Analysis Design method.

Project Information

A box for basic project information and identification of the document author is provided in the upper part of this form. This should match the information contained in the Basic Project Information section of the Building Envelope Summary (E-1) form.

Assembly ID: Insert a descriptor of the particular assembly. This may be a descriptor or number from the appropriate schedule in the plans. A separate item must be supplied for each group of assemblies that have unique U-values.

Area: Enter the Total area (in ft²) for that assembly (roof, wall, or floor) on a project-wide basis. For the System Standards method, this would be the area for that assembly on an orientation basis. The values from all entries in this column should be summed into the box marked "Total Area" at the bottom of the column.

U-Value: Enter the appropriate property for each assembly. Overall thermal transmittance of assemblies must be calculated in accordance with s. Comm 63.18. The calculation procedure must consider the effect of framing.

If skylights are installed, they must be included in the overall U-value calculation of the roof unless an exemption is obtained under s. Comm 63.12. A skylight exemption worksheet (E-4) must be included.

U•Area: This column is the product of the assembly area (second column) by the assembly U-value. The values from all entries in this column should be summed into the box marked "Total U•Area" by the value in "Total Area."

The area-weighted U-value is calculated by dividing the value in "Total U•Area" by the value in "Total Area."

SKYLIGHT EXEMPTION WORKSHEET E-4

This worksheet is applicable when skylights are exempt from the roof area overall U-value calculation per the requirements of Comm 63.12. It may be used with any method of compliance.

Project Information

A box for basic project information and identification of the document author is provided in the upper part of this form. This should match the information contained in the Basic Project Information section of the Building Envelope Summary (E-1) form.

Skylight Exemption Worksheet

All of the boxes except the item marked "Special Consideration" (50% shading device credit) must be filled in with a check or "X" to indicate affirmation. The 50% shading device credit box must be filled in with either a check, "X," or "N/A."

All of the "Design" and "Requirement" information must be completed. The skylight-to-roof ratio requirement is the maximum percent of skylight area taken from ASHRAE 90.1, Tables 8-3a and 8-3b of Table A63.12. The maximum area will depend on the visible light transmittance (VLT) and whether or not shading is provided for the skylight.

The lighting power density may be taken from the allowed lighting power density from s. Comm 63.47, 63.48, or 63.49, or the actual installed lighting power density adjusted for controls under s. Comm 63.45 (2) may be used.

The design lighting level, in foot-candles, is the judgment of the designer, but should be in general agreement with the recommendations of the Illuminating Engineering Society. (Refer to the IES Lighting Handbook, application volume, 1987.) The designer should choose the lighting level in the table closest to the condition in the proposed building. Interpolation or extrapolation for lighting level is not permitted.

OPAQUE TRADE-OFF WORKSHEET E-5

This worksheet is applicable to projects that demonstrate compliance through Opaque Trade-Offs as used with the requirements of Comm 63.15 (3) & (4).

Project Information

A box for basic project information and identification of the document author is provided in the upper part of this form. This should match the information contained in the Basic Project Information section of the Building Envelope Summary (E-1) form.

Assembly ID: Insert a descriptor of the particular assembly. This may be a descriptor or number from the appropriate schedule in the plans. A separate item must be supplied for each group of assemblies that have unique U-values.

Area: Enter the Total area (in ft²) for that assembly (roof, wall, or floor) on a project-wide basis. For the System Standards method, this would be the area for that assembly on an orientation basis. The values from all entries in this column should be summed into the box marked "Total Area" at the bottom of the column.

U-Value: Enter the appropriate property for each assembly. Overall thermal transmittance of assemblies must be calculated in accordance with s. Comm 63.18. The calculation procedure must consider the effect of framing.

If skylights are installed, they must be included in the overall U-value calculation of the roof unless an exemption is obtained under s. Comm 63.12. A skylight exemption worksheet (E-4) must be included.

U•Area: This column is the product of the assembly area (second column) by the assembly U-value.

Total Design U•Area: Add all U•Area values associated with the Design column. The U•Area values are to be derived from the designed roofs, walls adjacent to unconditioned spaces, above grade exterior walls, and floors over unconditioned spaces.

Total Required U•Area: Add all U•Area values associated with the Requirement column. The U•Area values are to be derived from code required roofs, walls adjacent to unconditioned spaces, above grade exterior walls, and floors over unconditioned spaces

Compliance is shown when the "Total Design U•Area" is less than or equal to the "Total Required U•Area."

BUILDING ENVELOPE SUMMARY

E-1



Transaction ID#	Submitter's Name
Owner's Name	Date
Building Location (Number & Street)	City Village Township of

Compliance Approach **Component Standards** **System Standards** **System Analysis Design**
 (See Comm 63.15) (See Comm 63.16) (See Comm 63.70-72)
Region **ACP Table** (See Fig. 63.15-2)

Basic Requirements		Prescriptive/Performance Requirements			Additional Data	
		Fenestration Properties	Design	Requirement		
<input type="checkbox"/>	U-values reported on this form are area-weighted averages. Comm 63.18 (1)				<input type="checkbox"/>	Fenestration Worksheet (E-2)
<input type="checkbox"/>	Windows and doors meet the air infiltration requirements. Comm 63.11	Window Area (WA) Comm 63.05 (79)	_____	If using Component Standards, see ACP Table Fig. 63.15-2	<input type="checkbox"/>	Opaque Surfaces Worksheet (E-3)
<input type="checkbox"/>	Fenestration U-values are certified by NFRC or from Table 63.18-3. Comm 63.18 (2) (b)	Gross Wall Area (GWA) Comm 63.05 (27) Comm 63.18 (2) (b) & (3)	_____		<input type="checkbox"/>	
<input type="checkbox"/>	Fenestration shading coefficients are obtained from either the 1989 ASHRAE Handbook of Fundamentals or manufacturer's data. Comm 63.18 (4)	Window-Wall Ratio (WA/ GWA) Comm 63.05 (80)	_____	≤ _____	<input type="checkbox"/>	Skylight Exemption Worksheet (E-4)
<input type="checkbox"/>	Exterior joints, cracks, and holes in the building envelope are caulked, gasketed, weather stripped, or otherwise sealed. Comm 63.11	Window U-value Comm 63.18 (2) (b) Window SCx Comm 63.18 (4)	_____ _____		<input type="checkbox"/>	Opaque Trade-off Worksheet (E-5) Marked Up ACP Table Included
<input type="checkbox"/>	Double entry vestibule? (Optional—check if provided)	Skylights Installed	_____ Yes	_____ No	<input type="checkbox"/>	
<input type="checkbox"/>	U-values reported on this form are area-weighted averages. Comm 63.18 (1)	Wall Design			<input type="checkbox"/>	COMcheck-EZ Report Included
<input type="checkbox"/>	An approved method which accounts for the thermal bridging of framing is used to calculate U-values for envelope assemblies. Comm 63.18 (2)	U-value Comm 63.18 (2) (a) Heat Capacity (HC) Comm 63.05 (34) Appendix A63.15 (3) (b)	_____ _____		<input type="checkbox"/> <input type="checkbox"/>	ENVSTD Output Included
<input type="checkbox"/>	Exterior joints, cracks, and holes in the building envelope are caulked, gasketed, weather stripped, or otherwise sealed. Comm 63.11	Insulation position (interior or exterior) Comm 63.05 (44)	_____		<input type="checkbox"/>	
<input type="checkbox"/>	Vapor barriers are installed to prevent deterioration of insulation performance. Comm 63.11 (4)	U-Values Roof Comm 63.18 (2) (a)	_____	≤ _____	<input type="checkbox"/>	
<input type="checkbox"/>	Special Consideration The skylight exemption is applied. Comm 63.12	Walls adjacent to unconditioned space Comm 63.18 (2) (a)	_____	≤ _____	<input type="checkbox"/>	
	(Attach Skylight Exemption Worksheet E-4)	Floors over unconditioned space Comm 63.18 (2) (a)	_____	≤ _____	<input type="checkbox"/>	
<input type="checkbox"/>	R-values reported on this form for slab-on-grade floors and walls before grade include only the insulating material. Comm 63.15 (5) and (6)	R-Values Walls below grade Comm 63.18 (2) (a)	_____	≥ _____	<input type="checkbox"/>	
<input type="checkbox"/>	Insulation continuity is maintained. Comm 63.15 (5)	Slab-on-grade Comm 63.18 (2) (a)	_____	≥ _____	<input type="checkbox"/>	

BUILDING ENVELOPE SUMMARY

E-2



Transaction ID#	Submitter's Name
Owner's Name	Date
Building Location (Number & Street)	City Village Township of

Fenestration Orientation:
For System Standards Method

Area-Weighted Properties – Comm 63.18

Fenestration U-Value (U_{of}) see Comm 63.18 (2) (b)

Assembly ID	Area	U-Value	U•Area
		X	=
		X	=
		X	=
		X	=
		X	=
		X	=
		X	=
		X	=
Total Area →		Total U•Area →	

$$\frac{\text{Total U} \cdot \text{Area}}{\text{Total Area}} = \boxed{}$$

Fenestration Shading Coefficient (SC_x) see Comm 63.18 (4)

Assembly ID	Area	SC _x	SC _x •Area
		X	=
		X	=
		X	=
		X	=
		X	=
		X	=
		X	=
		X	=
Total Area →		Total SC _x •Area →	

$$\frac{\text{Total SC}_x \cdot \text{Area}}{\text{Total Area}} = \boxed{}$$

OPAQUE SURFACES WORKSHEET

E-3



Transaction ID#	Submitter's Name
Owner's Name	Date
Building Location (Number & Street)	City Village Township of

Fenestration Orientation:

For System Standards Method

Area-Weighted Properties - Comm 63.18

Roofs see Comm 63.18 (2) (a)

Assembly ID	Area	U-Value	U•Area
		X	=
		X	=
		X	=
		X	=
Total Area →		Total U•Area →	

$$\frac{\text{Total U•Area}}{\text{Total Area}} = \boxed{}$$

Walls Adjacent to Unconditioned Spaces see Comm 63.18 (2) (a)

Assembly ID	Area	U-Value	U•Area
		X	=
		X	=
		X	=
		X	=
Total Area →		Total U•Area →	

$$\frac{\text{Total U•Area}}{\text{Total Area}} = \boxed{}$$

Above Grade Exterior Walls see Comm 63.18 (2) (a)

Assembly ID	Area	U-Value	U•Area
		X	=
		X	=
		X	=
		X	=
Total Area →		Total U•Area →	

$$\frac{\text{Total U•Area}}{\text{Total Area}} = \boxed{}$$

Floors Over Unconditioned Spaces see Comm 63.18 (2) (a)

Assembly ID	Area	U-Value	U•Area
		X	=
		X	=
		X	=
		X	=
Total Area →		Total U•Area →	

$$\frac{\text{Total U•Area}}{\text{Total Area}} = \boxed{}$$

SKYLIGHT EXEMPTION WORKSHEET

E-4



Transaction ID #	Submitter's Name		
Owner's Name	Date		
Building Location (Number & Street)	City	Village	Township of

Skylight Exemption Requirements see Comm 63.12		Additional Data	
<input type="checkbox"/> U-values of skylight curbs are less than 0.21 Btu/hr•ft ² •°F.	Skylight Design Data	Design	Requirement
<input type="checkbox"/> Overall thermal transmittance of skylight assemblies is less than 0.70 Btu/hr•ft ² •°F.	Skylight Area (SA)	_____	
	Gross Roof Area (GRA)	_____	
	Skylight-to-Roof Ratio (SA/GRA)	_____	≤ _____
<input type="checkbox"/> Air leakage is less than 0.5 cfm/ft ² of skylight.			
<input type="checkbox"/> Automatic daylighting controls installed to reduce electric lighting by 50%.	Skylight U-value	_____	
	Skylight VLT	_____	
Special Consideration	Lighting Power Density (LPD/ft ²)	_____	
<input type="checkbox"/> Shading devices used to block 50% of the solar gain during peak cooling conditions.	Design lighting level (footcandles)	_____	
			<input type="checkbox"/> ENVSTD output
			<input type="checkbox"/> Calculation of allowed skylight percent.
			<input type="checkbox"/> Sketch of shading devices.

OPAQUE ASSEMBLY TRADE-OFF WORKSHEET E-5



Transaction ID#	Submitter's Name
Owner's Name	Date
Building Location (Number & Street)	City Village Township of

DESIGN

Design – Roofs see Comm 63.18 (2) (a)

Assembly ID	Area	U-Value	U•Area
	×		=
	×		=
	×		=
	×		=
Total Area →			

Design – Above Grade Exterior Walls
see Comm 63.18 (2) (a)

Assembly ID	Area	U-Value	U•Area
	×		=
	×		=
	×		=
	×		=

Design – Walls Adjacent to Unconditioned Space
see Comm 63.18 (2) (a)

Assembly ID	Area	U-Value	U•Area
	×		=
	×		=
	×		=
	×		=
Total Area →			

Design – Floors Over Unconditioned Space
see Comm 63.18 (2) (a)

Assembly ID	Area	U-Value	U•Area
	×		=
	×		=
	×		=
	×		=
Total Area →			

REQUIREMENT

Required – Roofs see Comm 63.15 (4)

Total Area	Required U-Value	U• Area
×		=

Required – Above Grade Exterior Walls
See Comm 63.15 (4)

Total Area	Required U-Value	U• Area
×		=

Required – Walls Adjacent to Unconditioned Space
See Comm 63.15 (4)

Total Area	Required U-Value	U• Area
×		=

Required – Floors Over Unconditioned Space
See Comm 63.15 (4)

Total Area	Required U-Value	U• Area
×		=

III. LIGHTING PLAN CHECK DOCUMENTS

This section describes the forms and procedures for documenting compliance with the lighting energy efficiency requirements of the code. It does not describe the details of the requirements; these are presented in the code. The following discussion is addressed to the designer preparing construction documents and compliance statements and to the plan reviewers who are examining those documents for compliance with the code.

The use of each form is briefly described below. The complete instructions for each form are presented in the following subsections.

L-1: Lighting Summary.

This information is required for every project involving lighting and lighting controls.

L-2: Exterior Lighting Power Worksheet.

This information is also required for every project involving lighting and lighting controls.

L-3: Installed Interior Lighting Power Worksheet.

This information is also required for every project involving lighting and lighting controls.

L-4: Complete Building/Area Category Methods Worksheet

This information will only be required when calculating the Interior Lighting Power Allowance using either the Complete Building Method or the Area Category Method.

L-5: Activity Method Worksheet.

This information will only be required when calculating the Interior Lighting Power Allowance using the activity method.

SBD-10377 (R.10/98)

LIGHTING SUMMARY L-1

The Lighting Summary (L-1) form is in four parts. A copy of these forms must be submitted to the Division along with the rest of the compliance submittal at the time of building plan review.

A. Lighting Summary (L-1) Part 1

Project Information

Part 1 of the Lighting Summary form asks for the project name and address and those people responsible for the lighting design and compliance forms. The project name and address should be the same as on the Building Envelope forms for the project.

Method of Interior Lighting Compliance

Check one of the four boxes:

- | | |
|--------------------|--|
| Complete Building: | If this box is checked, the Complete Building/Area Category Methods Worksheet (L-4) must be provided. |
| Area Category: | If this box is checked, the Complete Building/Area Category Methods Worksheet (L-4) must be provided. |
| Activity: | If this box is checked, the Activity Method Worksheet (L-5) must be provided. |
| Other: | If compliance for the project is demonstrated through the System Analysis Design method of ss. Comm 63.70-72 where all energy-using systems are considered together, check this box. A complete analysis must be provided. |

Basic Requirements

All of the boxes in this column must be filled with either a check or "X" to indicate affirmation or "N/A" to indicate not applicable. For exterior lighting, enter the Exterior Lighting Power (ELP) and the Exterior Lighting Power Allowance (ELPA). These are obtained from the Exterior Lighting Power Worksheet (L-2).

Prescriptive/Performance Requirements

Enter the Installed Interior Lighting Power (ILP) and the Interior Lighting Power Allowance (ILPA). The ILP is obtained from the Interior Lighting Power Allowance Worksheet (L-3). The ILPA is obtained from the Complete Building/Area Category Methods Worksheet (L-4) if either the Complete Building Method or the Area Category Method is used. The ILPA is obtained from the Activity Method Worksheet (L-5) if the if the Activity Method is used. The lighting power control credits box is filled with a check or "X" when control credits are taken, otherwise enter "N/A."

Worksheets

Indicate which worksheets are attached.

B. Lighting Summary (L-1) Parts 2 to 4

Parts 2 to 4 of the Lighting Summary should be used to describe the installed lighting schedule, and the control devices associated with the building design. If necessary, make extra copies of the forms. The information on the L-1 parts 2 to 4 forms may be incorporated into equipment schedules on the plans along with light fixture information, rather than presented on the forms. If this is done, however, the same information should be included in one schedule and in a similar format as the forms.

Lighting Summary (L-1) Part 2

Luminaire Name: Record the description by name or type.

- Lamp Type:** Record the type of lamp (Incandescent, Fluorescent or High-Intensity discharge).
- Watts/Lamp:** Record the listed watts per lamp. For track and incandescent medium base socket fixture, see s. Comm 63.45 (4) for how to determine the watts of these types of luminaires. If track lighting is used and the fixtures are not shown on the Installed Lighting Schedule, 45 watts per foot of track is entered in this column.
- Ballasts Type:** Record the ballast type — Standard Energy-Saving Magnetic (S), Electronic High Frequency* (E) or Other* (O). If Electronic High Frequency or Other ballast types are used, the exact ballast type and model number should be specified.
- Number/Luminaire:** Record the number of ballasts installed in each Luminaire.

Mandatory Controls (L-1) Part 3

The Mandatory Controls portion is where those devices to meet the mandatory control requirements are listed. This would include devices for building shut-off, individual room control, and control of exterior lights. If some mandatory controls meet the requirements of s. Comm 63.45 (2), the information should also be recorded on Part 4, Automatic Controls for Credit, if control credits are taken in the ILP calculation.

- Control Location:** Record the location of the control on the plans.
- Control Identification:** Record the symbol of the control on the plans.
- Control Type:** Record the type of certified control device used to meet the mandatory automatic control requirement.
- Space Controlled:** Record the location of controlled lights.
Typical controls may be covered by general notation.

Automatic Controls for Credit (L-1) Part 4

The Automatic Controls for Credit portion is similar to the Mandatory Controls portion. The only difference is the last column.

- Luminaires Controlled:** Record the luminaire type and quantity controlled for credit.
- Type:** Record the same name as on the plans.
- Number of Luminaires:** Record the number of luminaires of that type that are controlled by the control type.
Typical controls may be covered by general notation.

Reviewer Notes

This space is used by the Department Plan Examiner during review of the submitted information.

EXTERIOR LIGHTING POWER WORKSHEET L-2

This worksheet is applicable to all projects.

Project Information

A box for basic project information and identification of the document author is provided in the upper part of this form. This should match the information contained in the Project Information section of the Lighting Summary (L-1) form.

Exterior Lighting Power Allowance — ELPA

- Area Description:** This is a descriptor of each line. These descriptors match those in Comm Table 63.43.
- Allowance:** This is the allowance in either W/ft^2 or watts of lineal feet. These allowances match those in Comm Table 63.43.
- Area or Lineal Feet in Proposed Design:** Record the area (ft^2) or lineal footage (lf) as appropriate. These values should be project-wide values.
- ELPA:** Multiply the allowance from Column B by the area (or lineal footage) from Column C. Record the resultant ELPA in Column D. The values should be summed into the box marked "Total ELPA" at the bottom of the column.

Installed Exterior Lighting Power

Do not include luminaires that are exempted under s. Comm 63.42.

- Fixture Type:** Record the description of the luminaires that are included.
- Number of Luminaires:** Record the total number of similar luminaires in the project.
- Watts per Luminaire:** Record the input wattage for each luminaire, including the ballast.
- Installed Wattage:** Multiply the number of luminaires from Column B by the wattage per luminaire from Column C. Enter the resultant installed wattage in Column D. The values from all entries in the column should be summed into the box marked "Total ELP" at the bottom of the column.

INSTALLED INTERIOR LIGHTING POWER WORKSHEET L-3

The Installed Interior Lighting Power Worksheet (L-3) will be completed and submitted with all applications. Either the Complete Building/Area Category Method Worksheet (L-4), the Activity Method Worksheet (L-5), or System Analysis Design documentation will be included with L-3, depending on the ILPA calculation method chosen.

Project Information

A box for basic project information and identification of the document author is provided in the upper part of this form. This should match the information contained in the Project Information section of the Lighting Summary (L-1) form.

Installed Interior Lighting Power

The calculated interior lighting power to be installed is determined by completing this form. *Do not include luminaires that are exempted under s. Comm 63.45.* If necessary, make extra copies of this form. Use as many sheets as needed for the project.

Luminaire Name or ID No.: Record the name or symbol. It should be consistent with what is used in the lighting schedule.

Description: Record a short list of the technical features (i.e., luminaire size and type, lamp type and number, ballast type, lens/louver type).

Number of Luminaires: Record the quantity of each fixture type in the building. If track lighting is used and the fixtures are not shown on the plans, the length of the track is entered in this column.

(Tip: If control credits are to be used and all of any type of luminaires are not controlled or used with the same control, split the luminaries up over several lines, one for each control type.)

Watts per Luminaire: Record the total wattage of each luminaire type (including ballasts for fluorescent or high intensity discharge fixtures). For track and incandescent medium base socket fixtures, see s. Comm 63.45 (4) for how to determine the watts of these types of luminaires. If track lighting is used and the fixtures are not shown on the Installed Lighting Schedule, 45 watts per foot of track is entered in this column. The wattage may be a standard value from the data in Table A63.45. Nonstandard values not from Table A63.45 must be substantiated with manufacturer's data sheets.

Total Watts: Record the product of the quantity of each luminaire listed times its watts per luminaire. If credit for automatic lighting controls is not sought, the interior lighting power is the sum of this Column E.

LPAF for Automatic Controls: If lighting power control credits are used, enter the appropriate lighting power adjustment factor from Table 63.45. If this credit is not used, leave Columns F, G, and H blank.

Control Credit: Multiply the total watts of luminaires associated with the control of Column E by the LPAF of Column F. Record the resultant control credit in Column G.

Adjusted Watts: Subtract the control credit of Column G from the total watts of Column E. Record the remainder in Column H.

The sum of Column E (or Column H if control credits are used) is the calculated interior lighting power for the building. If more than one sheet is used, enter the total for all sheets. This total cannot be greater than the Interior Lighting Power Allowance calculated on worksheet L-4 or L-5.

COMPLETE BUILDING/AREA CATEGORY METHODS WORKSHEET L-4

This worksheet will be attached to L-3 whenever the Complete Building Method or the Area Category Method is used to calculate the Interior Lighting Power Allowance.

Project Information

A box for basic project information and identification of the document author is provided in the upper part of this form. This should match the information contained in the Project Information section of the Lighting Summary (L-1) form.

Interior Lighting Power Allowance

The Interior Lighting Power Allowance (ILPA) is determined by calculating the maximum total watts of lighting that may be installed. As noted on the Lighting Summary, L-1, there are four different methods that may be used. These methods may not be mixed in the same building permit application. This form is used when the ILPA is calculated by the Complete Building or Area Category Method.

Complete Building Method

This method may only be used when plans and specifications for the entire building are included in the application.

Building Type of Use:	This is taken from Table 63.47 for the type of use of the building. If the building has a mixture of uses, the major use must be at least 80 percent of the conditioned floor area. If there is no major use, this method may not be used.
Watts per Square Foot:	Record the allowed lighting power density in watts per square foot for this building type taken from Comm Table 63.47.
Complete Building Area:	Record the conditioned floor area of the entire building, including the conditioned floor area of minor occupancies. See 63.05 (6) for the definition of conditioned floor area.
Allowed Watts:	Record the product of the watts per square foot times the complete building area. This becomes the Interior Lighting Power Allowance for the building.

Area Category Method

This method may be used when different primary function areas of a building are included in the application.

Primary Function:	This is taken from Comm Table 63.48 for the primary function of the area. If the building has a mixture of functions, each function area must be listed separately.
Watts per Square Foot:	Record the allowed lighting power density watts per square foot for this building type taken from Comm Table 63.48.
Area:	Record the conditioned floor area (in square feet) of the primary function area measured from the inside of partitions.
Allowed Watts:	Record the product of the watts per square foot times the primary function area. This becomes the allowed lighting power for the area.

The sum of the allowed lighting power for each primary function area is the Interior Lighting Power Allowance for the building.

ACTIVITY METHOD WORKSHEET L-5

This worksheet is applicable to all projects including those that use the Activity Method of s. Comm 63.49. If necessary, make extra copies of this form. Use as many sheets as needed for the project.

Project Information

A box for basic project information and identification of the document author is provided in the upper part of this form. This should match the information contained in the Project Information section of the Lighting Summary (L-1) form.

Interior Lighting Power Allowance — ILPA

- Column A: Record the room number or room name. A range of similar rooms may also be entered.
- Column B: Record the average ceiling height of the room in feet.
- Column C: Record a description of each line item. The description shall match the appropriate description from Table 63.49.
- Column D: Record any notes from Table 63.49. These notes may limit the Area Factor used in Activity Method calculations.
- Column E: Record the appropriate unit lighting power density (UPD) from Table 63.49.
- Column F: Record the floor area of the room (inside wall to inside wall, ft²). Where multiple rooms are included in single line, this is the average area of each type of room and not the total area of all rooms.
- Column G: Record the area factor from either s. Comm 63.49, Figure 63.49, or an applicable footnote from Table 63.49.
- Column H: Record the number of similar spaces.
- Column I: Multiply the UPD from Column E by the floor Column F by the area factor from Column G by the number of similar rooms from Column H. Record the resultant lighting power budget in Column I. The values from all entries in this column should be summed into the box marked "ILPA" at the bottom of the column.

LIGHTING SUMMARY

L-1 - Part 1 of 4



Transaction ID #	Submitter's Name		
Owner's Name	Date		
Building Location (Number & Street)	City	Village	Township of

Method of Interior Lighting Compliance (check one)

- Complete Building s. Comm 63.47
- Area Category s. Comm 63.48
- Activity s. Comm 63.49
- Other s. Comm 63.70-72

Basic Requirements	Prescriptive/Performance	Additional Data
<input type="checkbox"/> Exterior lighting not intended for 24-hour use controlled by photocell. Comm 63.50	$\frac{\text{Installed ELP}}{\text{ELPA Comm 63.43}} \leq \underline{\hspace{2cm}}$	Exterior Lighting Power Worksheet (L-2)
<input type="checkbox"/> Shut-off control in each space enclosed by ceiling-high partitions. Comm 63.50 (1) <input type="checkbox"/> Controls to reduce lighting by 50%. Comm 63.50 (2) <input type="checkbox"/> Controls to reduce lighting in daylit areas. Comm 63.50 (3) <input type="checkbox"/> Automatic shut-off controls. Comm 63.50 (4) <input type="checkbox"/> Display lighting separately switched on circuits ≤ 20 amps. Comm 63.50 (5) <input type="checkbox"/> Hotel/motel guest rooms have master switches at the main door to turn off lights and receptacles. Comm 63.50 (7)		
<input type="checkbox"/> Exit signs have installed wattage of 20 watts or less. Comm 63.52 <input type="checkbox"/> Fluorescent lamps use multiple lamp ballasts with tandem wiring as required. Comm 63.53	$\frac{\text{ILP}}{\text{ILPA Comm 63.47, 63.48, or 63.49}} \leq \underline{\hspace{2cm}}$ <input type="checkbox"/> Lighting Power Control Credits Applied. Comm 63.45 <ul style="list-style-type: none"> <input type="checkbox"/> Daylight Sensing Controls <input type="checkbox"/> Occupancy Sensors <input type="checkbox"/> Programmable Timing Controls <input type="checkbox"/> Lumen Maintenance Controls 	Interior Lighting Power Worksheet (L-3) Interior Lighting Power Allowance Worksheet (L-4) Activity Method Worksheet (L-5)

The information you provide may be used by other agency programs [Privacy Law, s. 15.04 (1)(m)].

SBD-10377 (R.10/98)

LIGHTING SUMMARY **L-1 - Part 3 of 4**



Transaction ID #	Submitter's Name		
Owner's Name	Date		
Building Location (Number & Street)	City	Village	Township of

MANDATORY CONTROLS (s. Comm 63.50)
 (Optional if included on plans - Use as many sheets as necessary)

Control Location (Room #)	Control Identification	Control Type (Occupancy Sens., Daylight, etc.)	Space Controlled	Note to Field

REVIEWER NOTES - For Department Use Only

LIGHTING SUMMARY **L-1 - Part 4 of 4**



Transaction ID #	Submitter's Name
Owner's Name	Date
Building Location (Number & Street)	City Village Township of

CONTROLS FOR CREDIT (s. Comm Table 63.45)
 (Optional if included on plans - Use as many sheets as necessary)

Control Location (Room # or Dwg.#)	Control Identification	Control Type (Occupant, Daylight, Dimming, etc.)	Luminaires Controlled		Note to Field
			Type	# of Lumin.	

REVIEWER NOTES - For Department Use Only

EXTERIOR LIGHTING POWER WORKSHEET L-2



Transaction ID #	Submitter's Name
Owner's Name	Date
Building Location (Number & Street)	City Village Township of

EXTERIOR LIGHTING POWER ALLOWANCE - ELPA (s. Comm 63.43)

A Area Description	B Allowance (Table 63.43)	C Area or Lineal Feet in Proposed Design	D ELPA (B•C)
Exit (with or without canopy)	25 W/lf of door opening		
Entrance (without canopy)	30 W/lf of door opening		
High Traffic Entrance (with canopy)	10 W/ft ² of canopied area		
Light Traffic Entrance (with canopy)	4 W/ft ² of canopied area		
Loading Area	0.40 W/ft ²		
Loading Door	20 W/lf of door opening		
Building Exterior Surfaces or	0.25 W/ft ² of illuminated		
Storage and Nonmanufacturing	0.20 W/ft ²		
Casual Use Areas (gardens, etc.)	0.10 W/ft ²		
Private Driveways or Walkways	0.10 W/ft ²		
Public Driveways or Walkways	0.15 W/ft ²		
Private Parking Lots	0.12 W/ft ²		
Public Parking Lots	0.18 W/ft ²		
Total ELPA			

INSTALLED EXTERIOR LIGHTING POWER - ELP (s. Comm 63.42)

A Fixture Type	B Number of Luminaires Installed	C Watts per Luminaire (including ballast)	D Installed Watts (B•C)
Total Installed ELP			

INSTALLED INTERIOR LIGHTING POWER WORKSHEET L-3



Transaction ID #	Submitter's Name		
Owner's Name	Date		
Building Location (Number & Street)	City	Village	Township of

INSTALLED INTERIOR LIGHTING POWER (s. Comm 63.45)

(Use as many sheets as necessary)

A	B	C	D	E	F	G	H
Luminaire Name or ID No.	Luminaire Description	Number of Luminaires	Watts per Luminaire (including ballast)	Total Watts (C•D)	LPAF for Automatic Controls (Table 63.45)	Control Credit (E•F)*	Adjusted Watts (E-G)
Total for this Sheet						Total for this Sheet	
Total for all Sheets (if control credits not taken)						Total for all Sheets (Adjusted with control credits)	

*Note: If control credits are taken. Form L-1. Part 3 must be completed or controls must be indicated on the plans.

COMPLETE BUILDING/AREA CATEGORY METHOD WORKSHEET L-4



Transaction ID #	Submitter's Name		
Owner's Name	Date		
Building Location (Number & Street)	City	Village	Township of

INTERIOR LIGHTING POWER ALLOWANCE (ILPA) (s.Comm 63.47 or 63.48)
 (Choose *one* method or use the Activity Method and Form L-5)

Complete Building Method

Building Type of Use From Table 63.47	Watts/ft ²	Complete Bldg. Area	Allowed Watts

Area Category Method

Primary Function From Table 63.48	Watts/ft ²	Area (ft sq.)	Allowed Watts
Totals			

ft² Area Watts

IV. HVAC SYSTEMS PLAN CHECK DOCUMENTS

This section describes the forms and procedures for documenting compliance of Heating, Ventilation and Air Conditioning (HVAC) systems with the **energy efficiency** requirements of the code. It does not describe the details of the requirements; these are presented in the code. Determination of compliance will be based on the actual code section. The following discussion is addressed to the designer preparing construction documents and compliance statements, and to the plan reviewers who examine those documents for compliance with the code.

Note: These forms cannot be used to demonstrate compliance with the Ch. Comm 64 ventilation requirements. That information must be provided separately.

The use of each form is briefly described below. The complete instructions for each form are presented in the following subsections.

H-1: HVAC Systems Summary.

This information is required for every project involving heating, ventilation and air conditioning equipment & systems.

H-2: HVAC Prescriptive Worksheet.

This information is applicable to projects that demonstrate compliance through a prescriptive means by following the requirements of Subchapter IV. It is not applicable to projects that demonstrate compliance through the System Analysis Design method of ss. Comm 63.70-72.

H-3: HVAC Equipment Summary.

This information is required for every project.

SBD-10375 (R.10/98)

HVAC SYSTEMS SUMMARY H-1

This worksheet is applicable to all projects

Project Information

This information asks for the project name and address and those people responsible for the HVAC design and compliance forms. The project name and address must match the information given on the building envelope forms. Check the box as indicated if the System Analysis Design method will be used to show compliance.

Basic Requirements Check List

All of the boxes in this column must be filled with either a check or "X" to indicate affirmation or "N/A" to indicate that the item or issue is not applicable.

Worksheet

If using the System Analysis Design method, the HVAC Prescriptive worksheet (H-2) does not need to be completed. Fill in the box with a check or "X" if it is included.

Special Considerations

Fill in these boxes with a check or "X" where applicable.

HVAC PRESCRIPTIVE WORKSHEET H-2

This worksheet provides detailed information on zone controls and economizer controls. It is not required if the System Analysis Design method is used.

Project Information

A box for basic project information and identification of the document author is provided in the upper part of this form. This should match the information contained in the Basic Project Information section of the HVAC Systems Summary (H-1) form.

Prescriptive Requirements

Each of the requirements is organized in a similar fashion. A major check box certifies compliance with each requirement. Each one of these is followed by a series of minor check boxes that are used to identify exceptions to that requirement. All of the major check boxes must be filled in with either a check, "X," or "N/A." In addition, a check or "X" should be placed in each applicable exception box. On the line adjacent to these exception descriptions, identify the systems or equipment to which the exception applies.

HVAC EQUIPMENT SUMMARY H-3

Project Information

A box for basic project information and identification of the document author is provided in the upper part of this form. This should match the information contained in the Basic Project Information section of the HVAC Equipment Summary (H-1) form.

Equipment Efficiency Information

Each piece of HVAC equipment that has efficiency requirements under ASHRAE 90.1 should be listed here. See Code Appendix A63.20 for reprinted standards.

- System ID Number: List the system identification number or zone identification number or other descriptor.
- Unit Type and Category: List the unit type and category from the appropriate table.
- Table Number: Give the table number, Table A63.20-1 through A63.20-15 of the Code Appendix, on which the equipment and its required efficiency are listed.
- Rated Output (Btu/h): This is the unit capacity (heating or cooling as appropriate) at rated conditions. The rating conditions should match those from the reference column of the corresponding table.
- Unit Efficiency: For each unit, list the efficiency of the selected unit at rated conditions on the left and the required minimum efficiency from the corresponding table on the right. Under "Rating Units" place "EER," "IPLV," "ET," etc., as applicable.

HVAC SYSTEMS WORKSHEET

H-1



Transaction ID #	Submitter's Name		
Owner's Name	Date		
Building Location (Number & Street)	City	Village	Township of

Check here if using System Analysis Design (see Comm 63.70-72)

	Basic Requirements Checklist	Additional Data
Design	<input type="checkbox"/> Load calculations involve the use of the minimum interior temperatures of Table Comm 64.05 for heating and Comm 63.23(2) for cooling as well as meet or exceed the minimum heating or maximum cooling outdoor design temperatures given in code. Comm 63.23(3) <input type="checkbox"/> Cooling pull-down/heating pick-up loads were either calculated or did not exceed 10%/30% of design load. Comm 63.23 (7) <input type="checkbox"/> Equipment is properly sized. Comm 63.24 <input type="checkbox"/> Process loads are served by separate systems from comfort conditioning loads. Comm 63.25 <input type="checkbox"/> HVAC fan and pumping system motors meet efficiency standards. Comm 63.32	HVAC Prescriptive Worksheet (H-2)
Controls	<input type="checkbox"/> Temperature controls are provided as required: one for each HVAC system and individual controls for each thermal zone. Comm 63.26 <input type="checkbox"/> Thermostatic controls meet the setpoint adjustment requirements: heating down to 55°F, cooling setpoints up to 85°F, and deadbands of 5°F minimum. Comm 63.26 <input type="checkbox"/> Systems do not reheat, recool or mix air. Comm 63.27* <input type="checkbox"/> Variable volume systems have minimum stops adjusted as required. Comm 63.27* <input type="checkbox"/> Each system that does not need to operate continuously is provided with either automatic time or setback/setup controls. Comm 63.27 (3) <input type="checkbox"/> Ventilation supply systems and exhaust systems are provided with either gravity or motorized dampers as required to limit infiltration during off hours. Comm 64.19 (5) <input type="checkbox"/> Combustion air dampers provided per Comm 64.09 (2) <input type="checkbox"/> A humidistat shall be provided if a system is equipped with a means for adding moisture to maintain specific humidity levels in a zone or zones. Comm 63.28 <input type="checkbox"/> Fan cooling systems employ air or water economizer controls. Comm 63.31* <input type="checkbox"/> Heat pumps with supplementary heaters have controls to prevent heater operation when heating load can be met by heat pump. Comm 63.22	
Completion & Construction	<input type="checkbox"/> Pipe insulation meets the requirements of Comm Table 63.29-1. Duct insulation meets the requirements of Table 63.29-2. Comm 63.29 <input type="checkbox"/> The plans or specifications spell out the requirements for leakage testing ductwork. Comm 64.34 <input type="checkbox"/> Low and medium pressure supply ductwork which is located outside of the conditioned space is sealed in accordance with SMACNA Seal Class C. Comm 64.34 <input type="checkbox"/> Complying air and water system balancing procedures are spelled out on the plans or in the specifications. Comm 64.53 <input type="checkbox"/> Testing, adjusting and calibration of control systems is spelled out on the plans or in the specifications. Comm 64.43 and Comm 64.53 <input type="checkbox"/> Plans or specifications require that equipment is provided with operation and maintenance manuals and system schematics. Comm 64.52	

Special Considerations: Heat recovery utilized Continuous system operation required

* If the ASHRAE 90.1 Energy Cost Budget method is used for system analysis design, these items do not have to be met prescriptively. Complete documentation must be provided.

The information you provide may be used by other agency programs [Privacy Law, s. 15.04 (1)(m)]

SBD-10375 (R 10/98)

HVAC PRESCRIPTIVE WORKSHEET

H-2



Transaction ID #	Submitter's Name		
Owner's Name	Date		
Building Location (Number & Street)	City	Village	Township of

Zone Controls - Constant Volume Systems Comm 63.27

Systems have controls which prevent simultaneous heating and cooling including: reheat, recool, mixing of heated and cooled airstreams, and simultaneous heating and cooling by separate systems within a zone.

System or Zone Number or ID

Exceptions

- 75% of reheat energy is from site-recovered or solar energy (provide documentation).
- System serves zones with process-driven humidity requirements.
- Multiple reheat systems serving multiple zones with controls or dual duct and multizone systems with controls to reset supply temperatures per Paragraphs (f), (g), or (n).
- Zones with a peak supply of 150 cfm or less or multizone systems with reheating or recooling limited to 5,000 cfm or 20%, whichever is less.

Zone Controls - Variable Volume Systems Comm 63.27

Before reheating or mixing of airstreams occur, zone controls must reduce the air supply to a minimum volume which is no greater than the largest of the following: (1) 30% of the peak supply volume, (2) the minimum required to meet ventilation requirements of Comm 64.05, or (3) 0.4 cfm/ft² of zone conditioned floor area.

System or Zone Number or ID

Exceptions

- There is no reheating or mixing of airstreams in these zones.
- Pressurization requirements prevent such reduction of airflow (provide documentation).
- 75% of reheat energy is from site-recovered or solar energy (provide documentation).
- System serves zones with process-driven humidity requirements.
- Zones with a peak supply of 150 cfm or less or multizone systems with reheating or recooling limited to 5,000 cfm or 20%, whichever is less.

Economizer Controls Comm 63.31

Fan-cooling systems are equipped with complying air or water economizers.

System Number or ID

Exceptions

- System capacity is less than either 2,000 cfm or 62,000 Btuh total cooling for a split system or less than 55,000 Btuh for all other types.
- Economizers would not save energy (provide documentation).
- Benefit of air economizer would be offset by increased energy use for humidity control.

A-63.05 (13) Daylit Area is the space on the floor that is the larger of (a) or (b);

(a) 1. For areas daylit by vertical glazing, the daylit area has a length of 15 feet, or the distance on the floor, perpendicular to the glazing, to the nearest 60-inch or higher opaque partition, whichever is less; and a width of the window plus either 2 feet on each side, the distance to an opaque partition, or one-half the distance to the closest skylight or vertical glazing, whichever is least.

2. For areas daylit by horizontal glazing, the daylit area is the footprint of the skylight plus, in each of the lateral and longitudinal dimensions of the skylight, the lesser of the floor-to-ceiling height, the distance to the nearest 60-inch or higher opaque partition, or one-half the horizontal distance to the edge of the closest skylight or vertical glazing.

(b) The daylit area calculated using a method acceptable to the department. Such methods include DOE 2.1D and E, Superlite, Quicklite and other computer-based models that determine the daylit area based on modeling the features of the space.

Figures A63.05-A and A63.05-B illustrate the determination of daylit areas. The dimensions given in Figure A63.05-B are for demonstration only and will vary with each space.

Figure A63.05-A Window Daylit Area

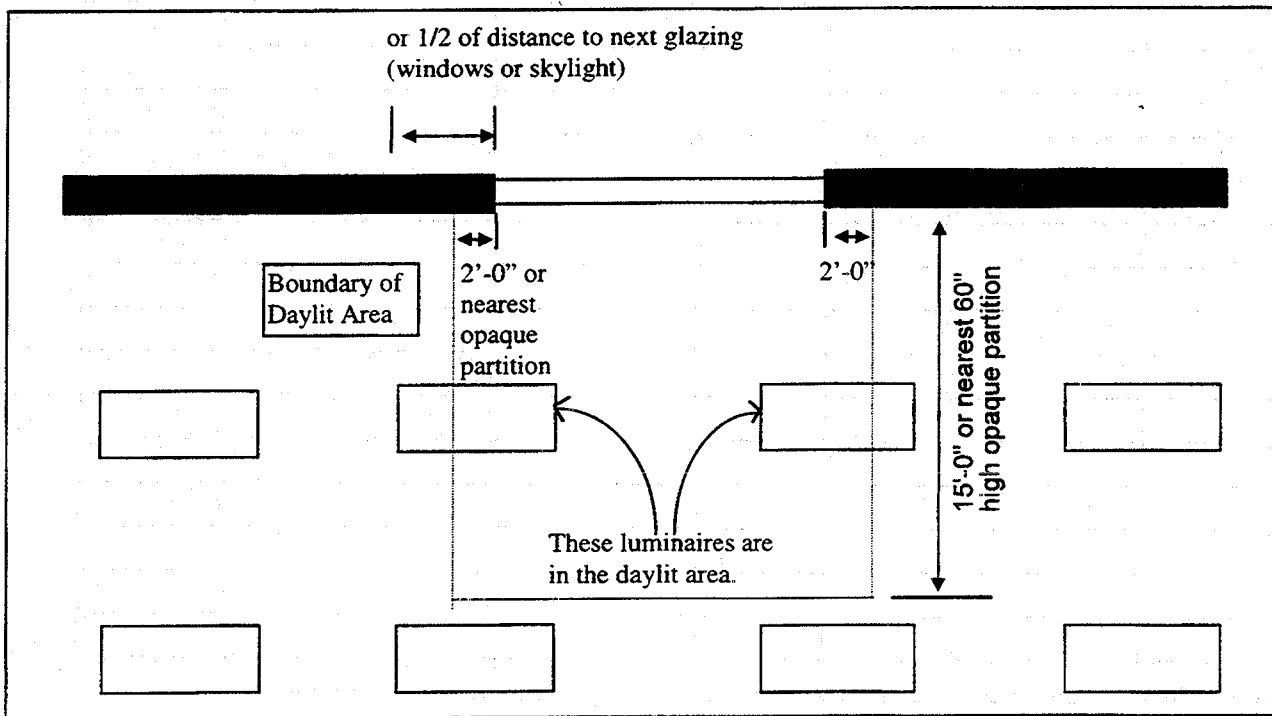

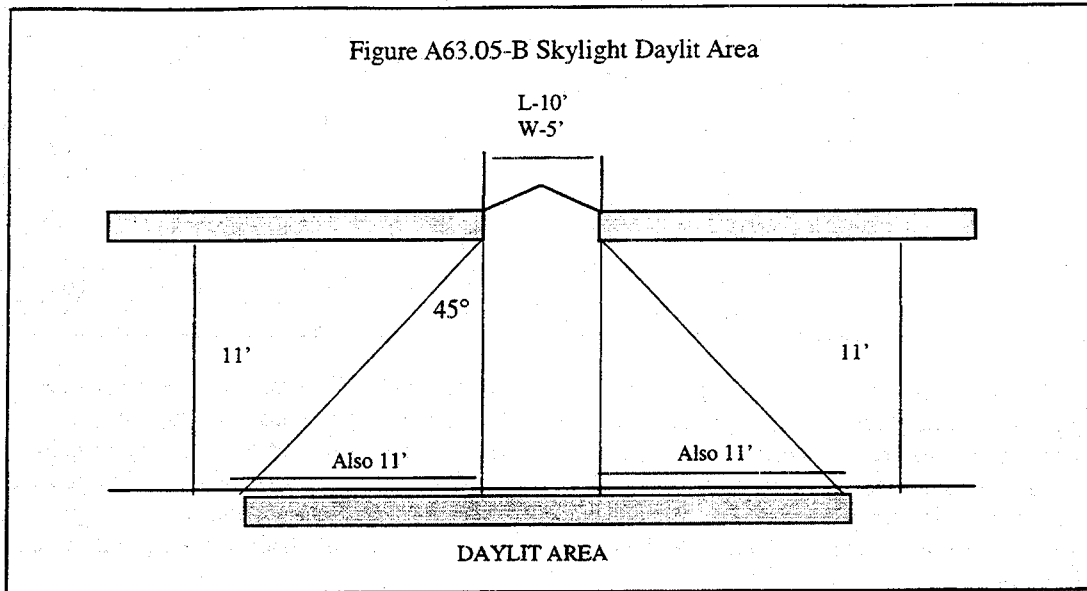

A63.12 Section 8.4.8 of ASHRAE Standard 90.1 requires the following criteria to be met for exemption of skylights:

- 1) The U-value of the opaque portion of the roof must be less than the criteria given in Figure 63.15;
- 2) Automatic daylighting controls are required;
- 3) The skylight U-value must be less than 0.70 Btu/hr°F;
- 4) The skylight curb U-value must be less than 0.21 Btu/hr°F;
- 5) The air leakage must be less than 0.5 cfm/ft² of skylight;
- 6) The maximum area of the skylight will depend on the visible light transmittance and whether shading is provided for the skylight.

**Table A63.12
Maximum Percent Skylight Area**

Visible Light Transmission (VLT)	Light Level (fc)	Range of Lighting Power (W/ft ²)				
		<1.00	1.01-1.50	1.51-2.00	2.01-2.50	>2.50
0.75	30	2.3	3.4	4.5	5.6	5.6
	50	2.5	4.0	5.5	7.0	7.0
	70	2.8	4.6	6.4	8.2	8.2
0.50	30	3.6	5.1	6.6	8.1	8.1
	50	3.9	6.0	8.1	10.2	10.2
	70	4.2	6.9	9.6	12.3	12.3

The maximum allowable skylight area may be increased by 50 percent if shading devices are installed that block more than 50 percent of the solar gain during the peak cooling design condition. If this credit is taken, calculations on data must be prepared that show that solar gains are reduced by 50 percent. Exterior shading devices such as fixed louvers on opaque parapet walls will qualify if all direct solar radiation is eliminated during the peak design condition. Integral, interior or movable exterior shading devices will qualify if they cut the shading coefficient in half when closed.

This summary is provided for general information only. For exact compliance criteria, see the ASHRAE 90.1 Standard.

A63.15 (3)(b) Heat Capacity (HC) of an assembly is the amount of heat necessary to raise the temperature of all the components of a unit area in the assembly one degree F. It is calculated as the sum of the average thickness times the density times the specific heat for each component, and is expressed in Btu per square foot per degree F.

Heat capacity describes the thermal mass of an assembly. It is used in the prescriptive envelope requirements for walls and floors, where the U-value criterion is tied to the heat capacity of the assembly.

For a single layer, homogeneous wall or floor, such as poured concrete walls with no applied finish materials, heat capacity can be calculated by multiplying the weight of the wall (pounds per square foot) times the specific heat. For instance, a 6-inch concrete wall (specific heat = 0.20 Btu/lb°F) with a weight of 70 pounds per square foot would have an HC of 70 x 0.20 or 14 Btu/sf°F. The wall weight is calculated from the density (pounds per square foot); density divided by 12 and multiplied by the thickness (inches) gives the wall weight (pounds per square foot).

For assemblies made up of many layers, HC may be calculated separately for each layer and summed.

The following Table A63.15-1 lists the thermal properties of typical, thermally massive construction materials.

The heat capacity of unit masonry walls, such as those made of concrete block or brick, are too complicated to calculate by this method. Tables A63.15-2 and A63.15-3 include HC calculated for a large variety of masonry wall assemblies. These tables also give the U-value (U) and the total R-value (Rt) for the wall, including interior and exterior air films.

A63.15-1 Thermal Mass Properties

Matter	Conductivity <u>Btu. in</u> hr.sf.°F	Density (lbs/cf)	Specific Heat (Btu/lb°F)
Adobe	0.33	120	0.20
Heavy Concrete	0.98	140	0.20
Lightweight Concrete	0.36	85	0.20
Gypsum	0.09	50	0.26
Masonry Veneer	0.62	127	0.20
Masonry Infill	0.44	120	0.20
Concrete Masonry Unit	0.59	105	0.20
Grouted Concrete Masonry Unit	1.00	134	0.20
Stucco	0.47	105	0.20
Tile in Mortar	0.67	120	0.20
Solid Wood (fir)	0.07	32	0.33

From: ASHRAE Handbook of Fundamentals, Table 4, Chapter 22

**Table A63.15-2 Properties of Hollow Unit
Masonry Walls**

Thickness/Material Type			Core Treatment		
			Solid Grout	Partly Grouted with UngROUTED Cells	
				Empty	Insulated
12"	LW CMU	U	0.51	0.43	0.30
		R _t	2.0	2.3	3.3
		HC	23.0	14.8	14.8
	MW CMU	U	0.54	0.46	0.33
		R _t	1.9	2.2	3.0
		HC	23.9	15.6	15.6
	NW CMU	U	0.57	0.49	0.36
		R _t	1.8	2.0	2.8
		HC	24.8	16.5	16.5
10"	LW CMU	U	0.55	0.46	0.34
		R _t	1.8	2.2	2.9
		HC	18.9	12.6	12.6
	MW CMU	U	0.59	0.49	0.37
		R _t	1.7	2.1	2.7
		HC	19.7	13.4	13.4
	NW CMU	U	0.62	0.52	0.41
		R _t	1.6	1.9	2.4
		HC	20.5	14.2	14.2
8"	LW CMU	U	0.62	0.50	0.37
		R _t	1.6	2.0	2.7
		HC	15.1	9.9	9.9
	MW CMU	U	0.65	0.53	0.41
		R _t	1.5	1.9	2.4
		HC	15.7	10.5	10.5
	NW CMU	U	0.69	0.56	0.44
		R _t	1.4	1.8	2.3
		HC	16.3	11.1	11.1
Clay Unit	U	0.57	0.47	0.39	
	R _t	1.8	2.1	2.6	
	HC	15.1	11.4	11.4	
6"	LW CMU	U	0.68	0.54	0.44
		R _t	1.5	1.9	2.3
		HC	10.9	7.9	7.9
	MW CMU	U	0.72	0.58	0.48
		R _t	1.4	1.7	2.1
		HC	11.4	8.4	8.4
	NW CMU	U	0.76	0.61	0.52
		R _t	1.3	1.6	1.9
		HC	11.9	8.9	8.9
	Clay Unit	U	0.65	0.52	0.45
		R _t	1.5	1.9	2.2
		HC	11.1	8.6	8.6

Notes:

LW CMU is a Light Weight Concrete Masonry Unit per ASTM C 90, calculated at 105 PCF density.

MW CMU is a Medium Weight concrete Masonry Unit per ASTM C 90, calculated at 115 PCF density.

NW CMU is a Normal Weight Concrete Masonry Unit per ASTM C 90, calculated at 125 PCF density.

Clay Unit is a hollow clay unit per ASTM C 652, calculated at 130 PCF density.

Values include thermal resistance of interior air film ($R = 0.68$) and exterior air film ($R = 0.17$).

Calculations based on Energy Calculations and Data, CMACN, 1986.

Grouted Cells at 32" x 48" in partly grouted walls

[Source: Berkeley Solar Group; Concrete Masonry Association of California and Nevada (CMACN).]

**Table A63.15-3 Properties of Solid Unit
Masonry and Solid Concrete Walls**

Type	Layer Thickness in Inches									
	3	4	5	6	7	8	9	10	11	12
LW CMU U	na	0.71	0.64	na	na	na	na	na	na	na
R _i	na	1.4	1.6	na	na	na	na	na	na	na
HC	na	7.00	8.75	na	na	na	na	na	na	na
MW CMU U	na	0.76	0.70	na	na	na	na	na	na	na
R _i	na	1.3	1.4	na	na	na	na	na	na	na
HC	na	7.67	9.58	na	na	na	na	na	na	na
NW CMU U	0.89	0.82	0.76	na	na	na	na	na	na	na
R _i	1.1	1.2	1.3	na	na	na	na	na	na	na
HC	6.25	8.33	10.42	na	na	na	na	na	na	na
ClayUnit U	0.80	0.72	0.66	na	na	na	na	na	na	na
R _i	1.3	1.4	1.5	na	na	na	na	na	na	na
HC	6.30	8.40	10.43	na	na	na	na	na	na	na
Concrete U	0.96	0.91	0.86	0.82	0.78	0.74	0.71	0.68	0.65	0.63
R _i	1.0	1.1	1.2	1.2	1.3	1.4	1.4	1.5	1.5	1.6
HC	7.20	9.60	12.00	14.40	16.80	19.20	21.60	24.00	26.40	28.80

Notes:

LW CMU is a Light Weight Concrete Masonry Unit per ASTM C 90 or 55, calculated at 105 PCF density.

MW CMU is a Medium Weight concrete Masonry Unit per ASTM C 90 or 55, calculated at 115 PCF density.

NW CMU is a Normal Weight Concrete Masonry Unit per ASTM C 90 or 55, calculated at 125 PCF density.

Clay Brick is a clay unit per ASTM C 62, calculated at 130 PCF density.

Concrete is structural poured or precast concrete, calculated at 144 PCF density.

Calculations based on Energy Calculations and Data, CMACN, 1986.

Values include thermal resistance of interior air film (R = 0.68) and exterior air film (R = 0.17).

[Source: Berkeley Solar Group; Concrete Masonry Association of California and Nevada (CMACN).]

A-63.18 (2)(a) 3.

Default U-Values for Wood and Steel Swinging Doors Btu/(h-ft²·°F) - Part I

Nominal Thickness (Inches)	Description	No. Storm Door	Wood Storm Door ^c	Metal Storm Door ^d
Wood Doors^{a,b}				
1 3/8	Panel door with 7/16" panels ^e	0.57	0.33	0.37
1 3/8	Hollow-core flush door	0.47	0.30	0.32
1 3/8	Solid-core flush door	0.39	0.26	0.28
1 3/4	Panel door with 7/16" panels ^e	0.54	0.32	0.36
1 3/4	Hollow-core flush door	0.46	0.29	0.32
1 3/4	Panel door with 1 1/8" panels ^e	0.39	0.26	0.28
1 3/4	Solid-core flush door	0.33	0.25	0.28
2 1/4	Solid-core flush door	0.27	0.20	0.21
Steel Doors^b				
1 3/4	Fiberglass or mineral wool core with steel stiffeners, no thermal break ^f	0.60	na	na
1 3/4	Paper honeycomb core without thermal break ^f	0.56	na	na
1 3/4	Solid urethane foam core without thermal break ^f	0.40	na	na
1 3/4	Solid fire-rated mineral fiberboard core without thermal break ^f	0.38	na	na
1 3/4	Polystyrene core without thermal break (18 gage Commercial steel) ^f	0.35	na	na
1 3/4	Polyurethane core without thermal break (18 gage Commercial steel) ^f	0.29	na	na
1 3/4	Polyurethane core without thermal break (24 gage Commercial steel) ^f	0.29	na	na
1 3/4	Polyurethane core with thermal break and perimeter (24 gage Commercial steel) ^f	0.20	na	na
1 3/4	Solid urethane foam core with thermal break ^a	0.19	0.16	0.17

Note: All U-Values for exterior doors in this table are for doors with no glazing, except for the storm doors which are in addition to the main exterior door. Any glazing area in exterior doors shall be included with the appropriate glass type and analyzed as fenestration. Interpolation and moderate extrapolation are permitted for door thicknesses other than those specified. In order to take credit for a thermal break, the door must have a thermal break in both the door slab and the frame.

^a Values are based on a nominal 32" by 80" door size with no glazing.

^b U-values include the thermal resistance of air films. Outside air conditions: 15 mph wind speed, 0°F air temperature; inside air conditions: natural convection, 70°F air temperature.

^c Values for wood storm door are for approximately 50% glass area.

^d Values for metal storm door are for any percent glass area.

^e 55% panel area.

^f ASTM C 236 hotbox data on a nominal 3' x 7' door size with no glazing.

Default U-Values for Sliding and Roll-Up Doors Btu/h-ft²-°F) - Part II

Door Description	Overall U-Factor
Uninsulated, single-layer	1.15
Nominal 2" thick with 1 3/4" polyurethane foam core and vinyl thermal breaks and section joint seals	0.14
Nominal 3" thick with 2 7/8" expanded polystyrene core and continuous vinyl extrusion to form a thermal break and weather-tight seal along section joint	0.12
Other doors	Use value from most similar swinging door above

Note: See s. Comm 51.06 for thermal barrier requirements for foam plastic insulation.

A63.20 Tables A63.20-1 through 10 specify the ASHRAE 90.1-1989 efficiency standards for equipment not covered by federal efficiency standards, but are covered by s. Comm 63.20.

Table A63.20-1
Standard Rating Conditions and Minimum Performance,
Unitary Air Conditioners and Heat Pumps
--Air-Cooled, Electrically Operated, <135,000 Btu/h Cooling Capacity--
Except Packaged Terminal and Room Air Conditioners

Reference Standards ^a	Category	Sub-Category & Rating Condition (Outdoor Temp. °F)	Minimum Performance ^c
ARI 210/240-89	<65,000 Btu/h Cooling Capacity Cooling Mode ^b	<u>Seasonal Rating</u> Split System Single Package	10.0 SEER 9.7 SEER
	≥65,000 and <135,000 Btu/h Cooling Mode	Standard Rating (95°F db) Integrated Part Load Value (80°F db)	8.9 EER 8.3 IPLV
	<65,000 Btu/h Cooling Capacity Heating Mode (Heat Pump) ^b	<u>Seasonal Rating</u> Split System Single Package	6.8 HSPF 6.6 HSPF
	≥65,000 and <135,000 Btu/h Cooling Capacity Heating Mode	<u>Split System & Single Package</u> High Temp. Rating (47°F db/43°F wb) Low Temp. Rating (17°F db/15°F wb)	3.0 COP 2.0 COP

^a For detailed references, see ASHRAE Standard 90.1.

^b Exception: the following equipment is not covered by s. Comm 63.20, but is covered by the National Appliance Energy Conservation Act (NAECA) of 1987 (Public Law 100-12): central air conditioners other than packaged terminal air conditioners which are powered by single phase electric current, air cooled, rated below 65,000 Btu per hour, not contained within the same cabinet as a furnace, the rated capacity of which is above 225,000 Btu per hour, and is a heat pump or a cooling unit only; and Heat pumps other than packaged terminal heat pumps which consist of one or more assemblies, powered by single-phase electric current, rated below 65,000 Btu per hour, utilizing an indoor conditioning coil, compressor, and refrigerant-to-outdoor air heat exchanger to provide air heating, and may also provide air cooling, dehumidifying, humidifying circulating, and air cleaning.

^c COP = Coefficient of Performance, EER = Energy Efficiency Ratio, IPLV = Integrated Part Load Value. See reference documents for detailed definitions.

Table A63.20-2
Standard Rating Conditions and Minimum Performance, Unitary Air Conditioners and Heat Pumps--Evaporatively Cooled, Electrically Operated, Cooling Mode <135,000 Btu/h Cooling Capacity--Except Packaged Terminal and Room Air Conditioners

Reference Standards ^a	Category	Rating Condition °F		Minimum Performance ^b
		Indoor Temp.	Outdoor Temp.	
ARI 210/240-89	<65,000 Btu/h Cooling Capacity	<u>Standard Rating</u>		9.3 EER
		95°F db/75°F wb		
CTI 201 (86)	<65,000 Btu/h	Integrated Part Load Value (80°F db/67°F wb)		8.5 IPLV
	≥65,000 but <135,000 Btu/h	<u>Standard Rating</u>		10.5 EER
	≥65,000 but <135,000 Btu/h	95°F db/75°F wb		9.7 IPLV

^a For detailed references, see ASHRAE Standard 90.1.

^b EER = Energy Efficiency Ratio, IPLV = Integrated Part Load Value. See reference documents for detailed definitions.

Table A63.20-3
Standard Rating Conditions and Minimum Performance, Water-Cooled Air Conditioners and Heat Pumps -- Electrically Operated and Cooling Mode <135,000 Btu/h Cooling Capacity

Reference Standards ^a	Category	Rating Condition °F		Minimum Performance ^b
		Indoor Air Temp.	Entering Water Temp.	
Water-Source Heat Pump	<65,000 Btu/h Cooling Capacity	<u>Standard Rating</u>		9.3 EER
		85		
ARI 320-86 CTI 201 (86)	≥65,000 but <135,000 Btu/h Cooling Capacity	<u>Low Temperature Rating</u>		10.2 EER
		75		
Groundwater Source Heat Pumps	<135,000 Btu/h Cooling Capacity	<u>Standard Rating</u>		11.0 EER
		70		
ARI 325-85	<65,000 Btu/h Cooling Capacity	<u>Low Temperature Rating</u>		11.5 EER
		50		
Water-Cooled Unitary Air Conditioners	<65,000 Btu/h Cooling Capacity	<u>Standard Rating</u>		9.3 EER
		85		
ARI 210/240-89 CTI 201 (86)	≥65,000 <135,000 Btu/h Cooling Capacity	<u>Integrated Part Load Value</u>		8.3 IPLV
		75		
		<u>Standard Rating</u>		10.5 EER
		85		

^a For detailed references, see ASHRAE Standard 90.1.

^b EER = Energy Efficiency Ratio, IPLV = Integrated Part Load Value. See reference documents for detailed definitions.

Table A63.20-4
Standard Rating Conditions and Minimum Performance, Packaged Terminal Air
Conditioners and Heat Pumps--Air-Cooled, Electrically Operated^a

Reference Standards ^c	Category PTACs & PTAC Heat Pumps	Sub-Category & Rating Conditions (Outdoor Temp. °F)	Efficiency Rating	Minimum Performance ^b
ARI 310-90	Cooling Mode	Standard Rating (95°F db)	EER	10.0 - (0.16 x Cap./1000)
		Low Temp. Rating (82°F db)	EER	12.2 - (0.20 x Cap./1000)
ARI 380-90	Heating Mode	Standard Rating (47°F db/43°F wb)	COP	2.9 - (0.026 x Cap./1000)

^a For multicapacity equipment, the minimum performance shall apply to each capacity step provided. Multicapacity refers to manufacturer published ratings for more than one capacity mode allowed by the product's controls.

^b Cap. means the rated cooling capacity of the product in Btu/h in accordance with the cited ARI Standard. If the unit's capacity is less than 7000 Btu/h, use 7000 Btu/h in the calculation. If the unit's capacity is greater than 15,000 Btu/h, use 15,000 Btu/h in the calculation. COP = Coefficient of Performance, EER = Energy Efficiency Ratio. See reference documents for detailed definitions.

^c For detailed references, see ASHRAE Standard 90.1.

Table A63.20-5
Standard Rating Conditions and Minimum Performance,
Water-Source and Groundwater-Source Heat Pumps
--Electrically Operated, <135,000 Btu/h Cooling Capacity

Reference Standards ^c	Rating Condition °F ^a	Minimum Performance ^d
Water-Source Heat Pumps ARI 320-86 CTI 201-(86)	<u>Standard Rating</u> 70°F Entering Water ^b	3.8 COP
Groundwater-Source Heat Pumps ARI 325-85	1. High Temperature Rating 70°F Entering Water ^b	3.4 COP
	2. Low Temperature Rating 50°F Entering Water ^b	3.0 COP

^a Air entering indoor section 70°F db/60°F wb (max.)

^b Water flow rate per manufacturer's specifications.

^c For detailed references, see ASHRAE Standard 90.1.

^d COP = Coefficient of Performance. See reference documents for detailed definitions.

**Table A63.20-6
Standard Rating Conditions and Minimum Performance,
Large Unitary Air Conditioners and Heat Pumps--
Electrically Operated >135,000 Btu/h Cooling Capacity**

Category Reference Standards ^c	Efficiency Rating ^d	Minimum Performance	
Air Conditioners ^a Air Cooled ARI 360-86	EER	≤760,000 Btu/h: 8.5	>760,000 Btu/h: 8.2
	IPLV	7.5	
Air Conditioners ^a Water/Evaporatively Cooled ARI 360-86 CTI 201-86	EER	9.6	
	IPLV	9.0	
Heat Pumps ^a Air Cooled-Cooling Air Cooled-Heating ARI 340-86	EER	<760,000 Btu/h: 8.5	≥760,000 Btu/h: 8.2
	IPLV	7.5	
	COP (47°F)	2.9	
	COP (17°F)	2.0	
Condensing Units ^b Air Cooled ARI 365-87	EER	9.9	
	IPLV	11.0	
Condensing Units ^b Water/Evaporatively Cooled ARI 365-87 CTI 201-86	EER	12.9	
	IPLV	12.9	

^a For units that have a heating section, deduct 0.2 from all required EERs and IPLVs

^b Condensing unit requirements are based on single-number ratings defined in paragraph 5.1.3.2 of ARI Standard 365.

^c For detailed references, see ASHRAE Standard 90.1.

^d COP = Coefficient of Performance, EER = Energy Efficiency Ratio, ILPV = Integrated Part Load Value. See reference documents for detailed definitions.

Table A63.20-7
Standard Rating Conditions and Minimum Performance,
Water Chilling Packages -- Water and Air Cooled and Electrically Operated

Reference Standards ^b	Category	Efficiency Rating ^c	Minimum Performance
ARI 550-90	Water-Cooled		
	≥300 Tons	COP	5.2 ^a
		IPLV	5.3 ^a
	≥150 Tons but <300 Tons	COP	4.2
		IPLV	4.5
	<150 Tons	COP	3.8
IPLV		3.9	
ARI 590-86	Air-Cooled With Condenser		
CTI 201-86	≥150 Tons	COP	2.5
		IPLV	2.5
<150 Tons	COP	2.7	
	IPLV	2.8	
	Air-Cooled Without Condenser		
	All Capacities	COP	3.1
		IPLV	3.2

^a Where R-22, or CFC refrigerants with ozone depletion factors less than or equal to those for R-22 is used, these requirements are reduced to 4.7 COP and 4.8 IPLV.

^b For detailed references, see ASHRAE Standard 90.1.

^c COP = Coefficient of Performance, EER = Energy Efficiency Ratio, ILPV = Integrated Part Load Value. See reference documents for detailed definitions.

**Table A63.20-8
Standard Rating Conditions and Minimum Performance,
Gas- and Oil-Fired Boilers**

Reference ^b	Category	Rating Condition	Minimum Performance ^c
ANSI Z21.13-87 H.I. Htg. Boiler Std. 86 ASME PTC 4.1-64 U.L. 795-73	Gas-Fired ≥300,000 Btu/h	1. Max. Rated Capacity ^a Steady-State	E _c 80%
		2. Min. Rated Capacity ^a Steady-State	E _c 80%
U.L. 726-90 H.I. Htg. Boiler Std. 86 ASME PTC 4.1-64	Oil-Fired ≥300,000 Btu/h	1. Max. Rated Capacity ^a Steady-State	E _c 83%
		2. Min. Rated Capacity ^a Steady-State	E _c 83%
H.I. Htg. Boiler Std. 86 ASME PTC 4.1-64	Oil-Fired (Residual) ≥300,000 Btu/h	1. Max. Rated Capacity ^a Steady-State	E _c 83%
		2. Min. Rated Capacity ^a Steady-State	E _c 83%

^a Provided and allowed by the controls.

^b For detailed references, see ASHRAE Standard 90.1.

^cE_c = Combustion efficiency, 100%-flue losses.

**Table A63.20-9
Standard Rating Conditions and Minimum Performance,
Warm Air Furnaces and Combination Warm Air
Furnaces/Air Conditioning Units**

Reference ^b	Category	Rating Condition	Minimum Performance ^c
ANSI Z21.47-90	Gas-Fired ≥225,000 Btu/h	1. Max. Rated Capacity ^a Steady-State	E _t 80%
		2. Min. Rated Capacity ^a Steady-State	E _t 78%
U.L. 727-86	Oil-Fired ^d ≥225,000 Btu/h	1. Max. Rated Capacity ^a Steady-State	E _t 81%
		2. Min. Rated Capacity ^a Steady-State	E _t 81%

^a Provided and allowed by the controls.

^b For detailed references, see ASHRAE Standard 90.1.

^cE_t = Thermal efficiency, 100%-flue losses. See referenced document for detailed definition.

**Table A63.20-10
Warm Air Duct Furnaces and Unit Heaters**

Reference ^b	Category	Rating Condition	Minimum Performance ^c
ANSI Z83.9-90	Duct Furnaces Gas-Fired	1. Max. Rated Capacity ^a Steady-State	E _t 78%
		2. Min. Rated Capacity ^a Steady-State	E _t 75%
ANSI Z83.8-90	Unit Heaters Gas-Fired	1. Max. Rated Capacity ^a Steady-State	E _t 78%
		2. Min. Rated Capacity ^a Steady-State	E _t 74%
U.L. 731-88	Unit Heaters Oil-Fired	1. Max. Rated Capacity ^a Steady-State	E _t 81%
		2. Min. Rated Capacity ^a Steady-State	E _t 81%

^a Provided and allowed by the controls.

^b For detailed references, see ASHRAE Standard 90.1.

^cE_t = Thermal efficiency, 100%-flue losses. See reference document for detailed definition.

Equipment efficiencies for the following appliances are established under federal Department of Energy rules 10 cfr Part 430 - Energy Conservation Program for Consumer Products and are not contained in this code:

Central air conditioners other than packaged terminal air conditioners which are powered by single phase electric current, air cooled, rated below 65,000 Btu per hour, not contained within the same cabinet as a furnace, the rated capacity of which is above 225,000 Btu per hour, and is a heat pump or a cooling unit only.

Furnaces which utilize only single-phase electric current, or single-phase electric current or DC current in conjunction with natural gas, propane, or home heating oil, and which comply with the following:

- (a) Are designed to be the principal heating sources for the living space of a residence;
- (b) Are not contained within the same cabinet with a central air conditioner whose rated cooling capacity is above 65,000 Btu per hour;
- (c) Are electric central furnaces, electric boilers, forced-air central furnaces; gravity central furnaces, or low pressure steam or hot water boilers, and
- (d) Have a heat input rate of less than 300,000 Btu per hour for electric boilers and low pressure steam or hot water boilers and less than 225,000 Btu per hour for forced-air central furnaces, gravity central furnaces, and electric central furnaces, gravity central furnaces, and electric central furnaces.

Heat pumps other than packaged terminal heat pumps which consist of one or more assemblies, powered by single-phase electric current, rated below 65,000 Btu per hour, utilizing an indoor conditioning coil, compressor, and refrigerant-to-outdoor air heat exchanger to provide air heating, and may also provide air cooling, dehumidifying, humidifying circulating, and air cleaning.

Direct heating equipment which is self-contained, and provides heat directly to the space proximate to the heater by gravity or fan circulation without duct connections.

The Department of Energy rules, section 430.31, requires the following efficiencies for heating and cooling equipment and water heaters.

Table A63.20-11
Room Air Conditioners

Product Class		Energy Efficiency Ratio
1.	Without reverse cycle and with louvered sides less than 6,000 Btu	8.0
2.	Without reverse cycle and with louvered sides 6,000 to 7,999 Btu	8.5
3.	Without reverse cycle and with louvered sides 8,000 to 13,999 Btu	9.0
4.	Without reverse cycle and with louvered sides 14,000 to 19,999 Btu	8.8
5.	Without reverse cycle and with louvered sides 20,000 and more Btu	8.2
6.	Without reverse cycle and without louvered sides less than 6,000 Btu	8.0
7.	Without reverse cycle and without louvered sides 6,000 to 7,999 Btu	8.5
8.	Without reverse cycle and without louvered sides 8,000 to 13,999 Btu	8.5
9.	Without reverse cycle and without louvered sides 14,000 to 19,999 Btu	8.5
10.	Without reverse cycle and without louvered sides 20,000 and more Btu	8.2
11.	With reverse cycle and with louvered sides	8.5
12.	With reverse cycle and without louvered sides	8.0

Table A63.20-12
Central Air Conditioners and
Central Heat Pumps

Product Class	Seasonal Energy Efficiency Ratio	Heating Seasonal Performance Factor
1. Split systems	10.0	6.8
2. Single package systems	9.7	6.6

**Table A63.20-13
Water Heaters**

Product Class	Energy Factor
1. Gas water heater	0.62-(.0019 x rated storage volume in gallons)
2. Oil water heater	0.59-(.0019 x rated storage volume in gallons)
3. Electric water heater	0.93-(.00132 x rated volume storage in gallons)

Note: Rated storage volume = the water storage capacity of a water heater, in gallons, as specified by the manufacturer.

**Table A63.20-14
Furnaces**

Product Class	AFUE ¹ (percent)
1. Furnaces (excluding classes noted below) (percent)	78
2. Mobile home furnaces (percent)	75
3. Small furnaces (other than furnaces designed solely for installation in mobile homes) having an input rate of less than 45,000 Btu/hr	
(A) Weatherized (outdoor)	78
(B) Nonweatherized (indoor)	78
4. Boilers (excluding gas steam) (percent)	80
5. Gas steam boilers (percent)	75

¹ Annual Fuel Utilization Efficiency, as determined in s. 430.22 (n)(2) of the DOE rules.

**Table A63.20-15
Direct Heating Equipment**

Product Class	Annual Fuel Utilization Efficiency (percent)
1. Gas wall fan type up to 42,000 Btu/hour	73
2. Gas wall fan type over 42,000 Btu/hour	74
3. Gas wall gravity type up to 10,000 Btu/hour	59
4. Gas wall gravity type over 10,000 Btu/hour up to 12,000 Btu/hour	60
5. Gas wall gravity type over 12,000 Btu/hour up to 15,000 Btu/hour	61
6. Gas wall gravity type over 15,000 Btu/hour up to 19,000 Btu/hour	62
7. Gas wall gravity type over 19,000 Btu/hour up to 27,000 Btu/hour	63
8. Gas wall gravity type over 27,000 Btu/hour up to 46,000 Btu/hour	64
9. Gas wall gravity type over 46,000 Btu/hour	65
10. Gas floor up to 37,000 Btu/hour	56
11. Gas floor over 37,000 Btu/hour	57
12. Gas room up to 18,000 Btu/hour	57
13. Gas room over 18,000 Btu/hour up to 20,000 Btu/hour	58
14. Gas room over 20,000 Btu/hour up to 27,000 Btu/hour	63
15. Gas room over 27,000 Btu/hour up to 46,000 Btu/hour	64
16. Gas room over 46,000 Btu/hour	65

A-63.29 ALTERNATIVE HVAC PIPING INSULATION TYPES. Insulation thicknesses in Table 63.29-1 are based on insulation with thermal conductivities within the range listed in Table 63.29-1 for each fluid operating temperature range, rated in accordance with ASTM C335-84 at the mean temperature listed in the table. For insulation that has a conductivity outside the range shown in Table 63.29-1 for the applicable fluid operating temperature range at the mean rating temperature shown (when rounded to the nearest 0.01 Btu in./ $(h \text{ } ^\circ\text{F ft}^2)$), the minimum thicknesses shall be determined in accordance with the equation given below:

$$T = PR[(1 + t/PR)^{K/k} - 1]$$

where:

T = minimum insulation thickness for material with conductivity K, in.

PR = pipe actual outside radius, in.

t = insulation thickness from Table 63.29-1 in.

K = conductivity of alternate material at the mean rating temperature indicated in Table 63.29-1 for the applicable fluid temperature range, Btu in./ $(h \text{ ft}^2 \text{ } ^\circ\text{F})$

k = the lower value of the conductivity range listed in Table 63.29-1 for the applicable fluid temperature range, Btu in./ $(h \text{ ft}^2 \text{ } ^\circ\text{F})$

Table A63.45-1
Typical Lighting Power for Magnetically Ballasted Fluorescent Lamp-Ballast Systems (watts)

	4 Lamps 2 Ballasts		3 Lamps 2 Ballasts		3 Lamps Tandem-Wired Ballasts		2 Lamps 1 Ballast	
	ANSI	Enclosed	ANSI	Enclosed	ANSI	Enclosed	ANSI	Enclosed
Standard Magnetic Energy Saving Ballasts								
31-watt FB31T8			105	97	104	96	69	64
32-watt F32T8	140	129	106	98	105	97	70	65
34-watt F40T12/ES	144	137	112	107	108	103	72	68
40-watt F40T12	176	160	134	121	129	117	88	80
40-watt FB40T12			134	121	129	117	86	78
40-watt F40T5 Twin Tube			130	120			86	79
60-watt F96T12/ES Slimline							123	
75-watt F96T12 Slimline							158	
95-watt F96T12/High Output/ES							199	
110-watt F96T12/High Output/ES							237	

Notes: Data listed are for standard energy efficient magnetic ballasts.

Values listed for 3-lamp systems with 2 magnetic ballasts have 1 single-lamp ballast and 1 double-lamp ballast.

Table A63.45-2
Typical Lighting Power for Electronically Ballasted Rapid-Start Fluorescent Lamp-Ballast Systems

Lamp/Ballast Combination	4 Lamps 1 Ballast		3 Lamps 1 Ballast		2 Lamps 1 Ballast		1 Lamp 1 Ballast	
	ANSI	Enclosed	ANSI	Enclosed	ANSI	Enclosed	ANSI	Enclosed
265 mA T-8 Lamps								
17-watt F17T8					34	33	16	15
25-watt F25T8			66	63	46	44	23	22
32-watt F32T8	120	116	90	87	61	59	31	30
40-watt F40T8			108		73	71	39	
T-12 and T-10 Lamps								
25-watt F30T12/ES			77		49	47	27	25
30-watt F30T12			87		59	57	32	30
34-watt F40T12/ES	117		90	87	62	60	31	30
40-watt F40T10			109	106	73	71	39	38
40-watt F40T12	140		106	103	72	70	38	36
40-watt FB40T12			100	93	67	62		
85-watt F72T12 High Output					164		82	
95-watt F96T12/HO/ES					170			
110-watt F96T12/HO					201			
Twin Tube Biax Lamps								
36-watt FT36T5 Twin Tube			106		72		37	
39-watt FT39T5 Twin Tube			104		70		37	
40-watt FT40T5 Twin Tube				69	67		37	
50-watt FT50T5 Twin Tube			125		106		54	

Notes: Data listed represents averages of rapid-start products available in 1994 from established manufacturers of electronic ballasts.

Actual input wattages for these system may be tuned by using specific products and will differ from these values.

Systems shown have minimum 0.85 ballast factor.

ANSI values listed for fluorescent systems assume open air operation of lamps where there is no solid lens between the lamp and the lighted space. Open suspended fixtures and heat extract type recessed troffers will have similar input values.

Input wattage values for enclosed lamps are generally less than they are under ANSI conditions. It is important to note that while input wattage is reduced in enclosed fixtures, so is light output.

Table A63.45-3
Typical Lighting Power for Electronically Ballasted Instant-Start Fluorescent Lamp-Ballast Systems
(watts)

Lamp/Ballast Combination	4 Lamps 1 Ballast		3 Lamps 1 Ballast		2 Lamps 1 Ballast		1 Lamp 1 Ballast	
	ANSI	Enclosed	ANSI	Enclosed	ANSI	Enclosed	ANSI	Enclosed
265 mA T-8 Lamps								
17-watt F17T8	62	60	50	49	34	32	18	17
25-watt F25T8	87	85	68	67	48	46	28	27
31-watt FB31T8			88	79	61	55	31	30
32-watt F32T8	110	104	89	88	61	57	33	31
36-watt F36T8	150		112		78			
55-watt F96T8					110			
T-12 Slimline Lamps								
55-watt F72T12					109			
60-watt F96T12 Slimline/ES					110		72	
75-watt F96T12 Slimline					135		85	
Twin Tube Biax Lamps								
39-watt FT39T5					64		42	
40-watt FT40T5			103		72		43	
55-watt FT55T5 Twin Tube						115		

Notes: Data listed represents averages of rapid-start products available in 1994 from established manufacturers of electronic ballasts. Actual input wattages for these system may be tuned by using specific products and will differ from these values. Systems shown have minimum 0.85 ballast factor.

Table A63.45-4
Typical Lighting Power for Electronically Ballasted Low-Wattage Reduced-Output
Fluorescent Lamp-Ballast Systems (watts)

Lamp/Ballast Combination	4 Lamps 1 Ballast		3 Lamps 1 Ballast		2 Lamps 1 Ballast		1 Lamp 1 Ballast	
	ANSI Watts	Ballast Factor	ANSI Watts	Ballast Factor	ANSI Watts	Ballast Factor	ANSI Watts	Ballast Factor
17-watt F17T8	54(RS)	0.77			27(RS)	0.77	14(RS)	0.77
25-watt F25T8	80(IS)	0.82			41(RS)	0.77	21(RS)	0.77
	79(RS)	0.77						
32-watt F32T8	99(IS)	0.79	79(IS)	0.82	54(IS)	0.82	28(RS)	0.77
	101(RS)	0.77	78(RS)	0.75	55(RS)	0.79		
34-watt F40T12/ES	117	0.83	85	0.83	61	0.83	31	0.82
39-watt F39T5 Twin Tube			73(IS)	0.63	52(IS)	0.64		
40-watt F40T5 Twin Tube					60(RS)	0.7		
40-watt F40T8			69(IS)	0.8	66(IS)	0.82		
					69(RS)	0.80		
40-watt F40T12			85	0	61	0.73	57	
40-watt F40T10					72	0.84	37	0.84
59-watt F96T8					105	0.83		
85-watt F72T12/HO					160	0.80		
110-watt F96T12						190	0.8	

Notes: All systems with ballast factor of <0.85

RS = rapid start operation

IS = instant start operation

Ballast factor listed is typical for the average input wattage given for all available products. Note that reducing the ballast factor decreases light output in addition to reducing input wattage.

**Table 63.45-5
Typical Lighting Power for Compact Fluorescent Lamps**

Lamp Type	Ballast Type	Input Watts
5-watt Twin Tube	Reactor preheat	9
7-watt Twin Tube	Reactor preheat	11
9-watt Twin Tube	Reactor preheat	13
13-watt Twin Tube	Reactor preheat	17
9-watt Quad Tube	Reactor preheat	13
13-watt Quad Tube	Reactor preheat	17
10-watt Quad Tube	Autotransformer preheat	16
	Reactor preheat	13
13-watt Quad Tube	Autotransformer preheat	18
	Reactor preheat	16
15-watt Quad Tube	Reactor preheat	20
18-watt Quad Tube	Autotransformer preheat	25
	Reactor preheat	22
18-20-watt Twin Tube	370 mA preheat or rapid start	22
18-watt Twin Tube	270 MA rapid start	23
	265 mA electronic IS	17
20-watt Quad Tube	Reactor preheat	27
24-27-watt Twin Tube	340 mA rapid start	32
	265 mA electronic IS	21
26-watt Quad Tube	Autotransformer preheat	37
	Reactor preheat HPF	33
	Electronic HPF	23
27-watt Quad Tube	Reactor preheat	34

Table A63.45-6
Typical Lighting Power for High-Intensity Discharge Lamps

Lamp Watts	Ballast Watts	Fixture Input Watts
Mercury Vapor Lamps		
75	15	90
100	18	118
175	25	200
250	35	285
400	50	450
1,000	75	1,075
Metal Halide Lamps		
32	6	38
50	13	63
70	18	88
100	25	125
175	35	210
250	42	292
400	55	455
1,000	70	1,070
High Pressure Sodium Lamps		
35	8	43
50	13	63
70	18	88
100	30	130
150	38	188
250	50	300
400	65	465
1,000	90	1,090

Notes: Source: Pacific Gas & Electric

Figures listed represent average values taken from Osram-Sylvania, Philips, and General Electric lamp catalogs.

A-64.20 EQUIPMENT RATINGS AND SAFETY CONTROLS. The department recognizes the following reference standards for the testing and installation of heating and ventilating equipment:

- (1) American National Standards Institute, Inc., 1430 Broadway, New York, N.Y. 10018:
 - (a) GAS WATER HEATERS, Vol. I, ANSI Z21.10.1
 - (b) GAS WATER HEATERS, Vol. III, ANSI Z21.10.3
 - (c) GAS-FIRED ROOM HEATERS, Vol. I, ANSI Z21.11.1;
 - (d) GAS-FIRED LOW PRESSURE STEAM AND HOT WATER BOILERS, ANSI Z21.13;
 - (e) GAS UNIT HEATERS, ANSI Z21.16;
 - (f) DOMESTIC GAS CONVERSION BURNERS, ANSI Z21.17;
 - (g) GAS APPLIANCE PRESSURE REGULATORS, ANSI Z21.18;
 - (h) AUTOMATIC GAS IGNITION SYSTEMS AND COMPONENTS, ANSI Z21.20;
 - (i) AUTOMATIC GAS VALVES, ANSI Z21.21;
 - (j) RELIEF VALVES AND AUTOMATIC GAS SHUTOFF DEVICES FOR HOT WATER SYSTEMS, ANSIZ21.22;
 - (k) GAS APPLIANCE THERMOSTATS, ANSI Z21.23;
 - (l) GAS-FIRED DUCT FURNACES, ANSI Z21.34;
 - (m) GAS FILTERS ON APPLIANCES, ANSI Z21.35;
 - (n) GAS-FIRED GRAVITY AND FAN TYPE DIRECT VENT WALL FURNACES, ANSI Z21.44;
 - (o) GAS-FIRED GRAVITY AND FORCED AIR CENTRAL FURNACES, ANSI Z21.47;
 - (p) GAS-FIRED GRAVITY AND FAN TYPE FLOOR FURNACES, ANSI Z21.48;
 - (q) GAS-FIRED GRAVITY AND FAN TYPE VENTED WALL FURNACES, ANSI Z21.49;
 - (r) VENTED DECORATIVE GAS APPLIANCES, ANSI Z21.50;
 - (s) GAS-FIRED SINGLE FIREBOX BOILERS, ANSI Z21.52;
 - (t) GAS-FIRED HIGH PRESSURE STEAM AND HOT WATER BOILERS (Inputs not over 400,000 Btu/hour), ANSI Z21.59;
 - (u) DECORATIVE GAS APPLIANCES FOR INSTALLATION IN VENTED FIREPLACES, ANSIZ21.60;
 - (v) DIRECT VENT CENTRAL FURNACES, ANSI Z21.64;
 - (w) DIRECT GAS-FIRED MAKE-UP AIR HEATERS, ANSI Z83.4;
 - (x) GAS-FIRED HEAVY DUTY FORCED AIR HEATERS, ANSI Z83.5;
 - (y) GAS-FIRED INFRARED HEATERS, ANSI Z83.6;
 - (z) GAS UNIT HEATERS, ANSI Z83.8;
 - (aa) GAS-FIRED DUCT FURNACES, ANSI Z83.9;
 - (bb) DIRECT GAS-FIRED DOOR HEATERS, ANSI 283.17; and
 - (cc) DIRECT GAS-FIRED INDUSTRIAL AIR HEATERS, ANSI Z83.18.
- (2) Canadian Standards Association, Certification Division, Rexdale, Ontario Canada, M9W 1R3:
 - (a) Solid-Fuel Fired Appliances for Residential Use, CSAB 366M.
- (3) Energy Testing Laboratory of Maine, South Maine Vocational Technical Institute, South Portland, Maine 04106.
 - (a) Testing for Safety—Requirements and Test Procedures for Solid-Fuel Burning Central Heating Appliances and Combination Oil- and Solid-Fuel Burning Central Heating Appliances, ETLM Standard #78-1.
- (4) International Conference of Building Officials, Inc., 5360 South Workman Mill Road, Whittier, California 90601:
 - (a) Research Committee Acceptance Criteria for Fireplace Heat Exchangers.
- (5) Underwriters' Laboratories, Inc., 333 Pfingsten Road, Northbrook, Illinois 60062:
 - (a) CHIMNEYS, FACTORY-BUILT, RESIDENTIAL TYPE AND BUILDING HEATING APPLIANCES, UL 103;
 - (b) FACTORY BUILT FIREPLACES, UL 127;
 - (c) OIL BURNERS, UL 296;
 - (d) CONTROLS, PRIMARY SAFETY FOR GAS- AND OIL-FIRED APPLIANCES, UL 372;
 - (e) SOLID-FUEL FIRED CENTRAL FURNACES, UL 391;
 - (f) GAS VENTS, UL 441;

- (g) HEATING APPLIANCES, ELECTRIC, UL 499;
- (h) HEAT PUMPS, UL 559;
- (i) TYPE L LOW-TEMPERATURE VENTING SYSTEMS, UL 641;
- (j) OIL-FIRED BOILER ASSEMBLIES, UL 726;
- (k) OIL-FIRED CENTRAL FURNACES, UL 727;
- (l) OIL-FIRED FLOOR FURNACES, UL 729;
- (m) OIL-FIRED WALL FURNACES, UL 730;
- (n) OIL-FIRED UNIT HEATERS, UL 731;
- (o) HEATERS, AIR AND DIRECT-FIRED HEATERS, OIL-FIRED, UL 733;
- (p) FIREPLACE STOVES, UL 737;
- (q) COMMERCIAL-INDUSTRIAL GAS HEATING EQUIPMENT (Inputs over 400,000 Btu/hour), UL 795;
- (r) HEATERS, ELECTRIC, FOR USE IN HAZARDOUS LOCATIONS; Class I, Groups A, B, C and D, and Class II, Groups E, F and G, UL 823;
- (s) ELECTRIC BOILERS, UL 834;
- (t) HEATERS, ELECTRIC DRY BATH, UL 875;
- (u) FAN COIL UNITS AND ROOM FAN HEATER UNITS, UL 883;
- (v) OIL-BURNING STOVES, UL 896;
- (w) HEATERS, ELECTRIC AIR, UL 1025;
- (x) HEATING EQUIPMENT, ELECTRIC BASEBOARD, UL 1042;
- (y) HEATING EQUIPMENT, ELECTRIC CENTRAL AIR, UL 1096; and
- (z) ROOM HEATERS, SOLID-FUEL TYPE, UL 1482.

The table on the following page is a tabular summary of UL 296 and UL 795.e.

TABULAR SUMMARY UL STANDARD 296 AND UL STANDARD 795

FUNCTION/BURNER INPUTS	OIL BURNERS UL 296				COMMERCIAL/INDUSTRIAL GAS UL 795				
	3 GPH	7 GPH	20 GPH	Over 20 GPH 3 million Btu	Mechanical Draft Burners				ATM Draft
	400,000 Btu or less	1 million Btu or less	3 million Btu or less		Over 400,000 to 2,500,000	Over 2,500,000 to 5,000,000	Over 5,000,000 to 12,500,000	Over 12,500,000	
Prepurge timing	--	--	--	--	4	4	4	4	90 sec ³
Air changes	--	--	--	--	4	4	4	4	--
Interlock Controls (Recycle)	Yes	Yes	Yes	Yes	Yes	Yes	Yes	Yes	Yes
Proven combustion air	8	8	8	8	Yes	Yes	Yes	Yes	--
Valve seal overtravel ⁹	--	--	--	--	--	Optional	Yes	Yes	13
Low gas pressure	--	--	--	--	--	Yes ²⁰	Yes ²⁰	Yes ²⁰	13
High gas pressure	--	--	--	--	--	Yes ²⁰	Yes ²⁰	Yes ²⁰	13
Low fire start	11	11	11	11	11	11	11	11	13
High limit (press. or temp.)	Yes	Yes	Yes	Yes	Yes	Yes	Yes	Yes	Yes
Low water cutoff	Boilers ²¹	Boilers ²¹	Boilers ²¹	Boilers ²¹	Boilers	Boilers	Boilers	Boilers	13
Pilot - Intermittent	Optional	Optional	Optional	--	Optional	Optional	Optional	Optional	12
Pilot - Interrupted	19	19	19	Yes ⁵	Optional	Optional ²	Optional ²	Optional ²	2, 10
Direct spark ignition	Yes	Yes	Yes	5	--	--	--	--	--
System & sequence approved safety control	Yes	Yes	Yes	Yes	Yes	Yes	Yes	Yes	Yes
Approved safety shutoff valves (SSOV)	IN	BURNER	DESIGN	--	Yes ¹⁴	Yes ¹⁴	Yes ¹⁴	Yes ¹⁴	Yes ^{13, 14}
No vent valve	--	--	--	--	--	--	--	Yes	13
Pilot valve	18	18	18	Yes	Yes ⁵	Yes	Yes	Yes	Yes
Proved pilot	Optional	Optional	Optional	Yes	Yes	Yes	Yes	Yes	Yes
Trial for pilot	17	17	17	15 sec	15 sec	10 sec	10 sec	10 sec	13
Trial for main flame	90 sec ^{2, 17}	30 sec ^{2, 17}	15 sec ^{2, 17}	10/30 sec ⁷	15 sec ²²	10 sec	10 sec	10 sec	13
Flame failure response time	90 sec ¹⁷	4 sec max ^{16, 17}	4 sec max ^{15, 17}	4 sec max	4 sec max	4 sec max	4 sec max	2 sec max	13
Valve closing time (max.)	23	23	23	23	5 sec max	1 sec max	1 sec max	1 sec max	13
Supervise main flame	17	17	17	Yes	--	Yes ²	Yes ²	Yes ²	2, 10
Action on flame failure	Recycle optional ¹	1	1	Lockout or recycle	Lockout or recycle ⁶	Lockout	Lockout	Lockout	13
Action on limit open	Close SSOV	Close SSOV	Close SSOV	Close SSOV	Close SSOV	Close SSOV	Close SSOV	Close SSOV	13

See following page for footnotes.

FOOTNOTES TO TABULAR SUMMARY UL STANDARD 296 AND UL STANDARD 795:

SSOV=Safety shutoff valve

¹May relight if ignition is re-energized within 0.8 sec. See 15 and 16.

²Where intermittent pilot is desired, it is allowable to switch from pilot detector to main flame detector if main flame detector responds to main flame only.

³Without shutters, no prepurge required.

⁴Options (whichever is chosen, a minimum of 4 air changes must be provided):

- 30 sec at high fire rate; OR
- 60 sec at 1/2 high fire rate; OR
- 90 sec at 1/3 high fire rate.

⁵With 2-stage lightoff, direct ignition is permitted if first stage is 20 gph or less (requirements for 20 gph or less apply). Pilot is required if igniting more than 20 gph.

⁶Lockout on interrupted pilot applications; recycle on intermittent pilot applications.

⁷10 sec for distillate fuel (No. 1 or No. 2); 30 sec for residual fuel (No. 4, 5, 6).

⁸Conventional type pressure burner—none needed. Needed for applications with combustion air supply separate from oil supply.

⁹Valve seal overtravel switch can be wired into either the start circuit or pre-ignition interlock circuit (if provided).

¹⁰Interrupted pilot over 2.5 million Btuh if modulating or high/low firing rate. Otherwise over 5 million Btuh.

¹¹If low fire start is not proved, UL will test for smooth lightoff at high fire.

¹²Intermittent up to 5 million Btuh unless firing rate control is over 2,500,000 Btuh.

¹³Requirements same as mechanical draft burners.

¹⁴See Table 1 at end of footnotes for main gas valves.

¹⁵Up to 15 sec is permitted if intermittent ignition is employed, or if the ignition system is re-energized in not more than 0.8 sec after flame is extinguished.

¹⁶Up to 30 sec is permitted if intermittent ignition is employed, or if the ignition system is re-energized in not more than 0.8 sec after flame is extinguished.

¹⁷If proved pilot igniter is used, timings for over 20 gal flame safeguard control may be applied.

¹⁸Required for electrically ignited, gas-piloted systems.

¹⁹Interrupted pilot may be required if using flame safeguard control with a proved pilot. Otherwise, interrupted pilot is optional.

²¹Safety shutdown by this limit can be accomplished either by manual reset limits or in the programmer limit circuit.

²¹Required on boilers fired by oil burners—not a requirement of UL 296.

²²If intermittent pilot is used, no main burner flame-establishing period is required.

²³If a separate oil valve is used, it must close within 5 sec max when de-energized.

TABLE 1—AUTOMATIC MAIN GAS SAFETY SHUT-OFF VALVES (SSOV) FOR MECHANICAL OR ATMOSPHERIC BURNERS—UL 795 REQUIREMENTS, EFFECTIVE OCTOBER 1, 1974

	400,000 to 2,500,000 BTUH	Over 2,500,000 to 5,000,000 BTUH	Over 5,000,000 to 12,500,000 BTUH	Over 12,500,000 BTUH
Main Valve Requirement	One valve rated for safety shutoff services(SSOV). Closing-time 5 sec.	Two SSOV's in series, or one SSOV of the type incorporating a valve seal overtravel interlock. Closing time 1 sec max.	Two SSOV's in series, one of which incorporates a valve seal overtravel interlock. Closing time 1 sec max.	Two SSOV's in series, one of which incorporates a valve seal overtravel interlock. When fuel gas has specific gravity of less than 1.0, include a N.O. 3/4 inch or larger electrically operated valve in a vent line between the two SSOV's.