

NR 112 *Nov May*
Reg 200
135

Chapter RD 12

WELL CONSTRUCTION AND PUMP INSTALLATION

| | | | |
|----------|---|----------|---|
| RD 12.01 | Scope of the code | RD 12.10 | Well construction equip- ment |
| RD 12.02 | Basic principles | RD 12.11 | Concrete and grout mix- tures |
| RD 12.03 | Definitions | RD 12.12 | Use of wells for drain- age purposes |
| RD 12.04 | Location | RD 12.13 | Abandonment of wells |
| RD 12.05 | Design and construction | RD 12.14 | Orders |
| RD 12.06 | Surface protection | RD 12.15 | Existing installations |
| RD 12.07 | Miscellaneous well con- struction requirements | | |
| RD 12.08 | Samples and reports | | |
| RD 12.09 | Pump installation and construction | | |

NR 12.01

RD 12.01 Scope of the code. (1) **APPLICABILITY.** The provisions of the regulations governing well construction and pump installation shall apply to all new or reconstructed wells intended or used for supplying water for human consumption, including those used in the production and preparation of food and food products, excepting those for public utility and institutional water supplies, cooperative water supplies serving 10 or more premises of mixed ownership, and new, additional or reconstructed wells on one property, whose capacity and rate of pumping, either singly or in the aggregate, are in excess of 100,000 gallons per day.

(2) **APPROVED COMPARABLE CONSTRUCTION.** When strict compliance with this code appears to be impracticable, the reasons therefor shall be communicated in writing to the department of resource development for advice and approval of comparable specifications.

(3) **CONTRACT APPLICABILITY.** Applicable specifications and provisions of this code are, by law, a part of any order or agreement, written or verbal, for the construction or reconstruction of a well or appurtenances thereto, or for the installation of pumping equipment. Construction or installation shall be deemed complete when all code requirements or approved comparable specifications are complied with. (See Wis. Adm. Code section RD 12.08 (1)).

(4) **EXISTING INSTALLATIONS.** Existing well and pump installations that conform to section RD 12.15 will be acceptable. Non-complying pit and pump installations made prior to the effective date of this section shall be corrected to comply with section RD 12.15 or the regulations for new construction before January 1, 1956. Well and pump installations that are unsafe should be corrected as soon as possible.

History: 1-2-56; renum. from H 55.01 to be RD 12.01, and am., Register, June, 1967, No. 138, eff. 7-1-67.

RD 12.02 Basic principles. (1) **GENERAL.** Regulations are hereby prescribed to establish uniform minimum standards and methods of procuring and protecting an adequate supply of ground water safe and fit for human consumption and for the preparation of food products through adequate construction or reconstruction of wells, installation of pumping equipment, or other methods approved by the department of resource development, in conformity with chapter 162, Wis.

NR
112.01
Nov
May
Reg
200
135
135
135
135

Stats. The following basic principles, general in scope and fundamental in character, shall govern the location, construction or reconstruction and maintenance of wells, installation and maintenance of pumping equipment, and supervision of well constructors and pumping equipment installers.

(2) **WELL CONSTRUCTION.** Where a well is constructed to supply ground water for human consumption and preparation of food products, such well shall be:

(a) Located in such manner that the well and its surroundings can be kept in a sanitary condition.

(b) Adequate in size to permit such construction or reconstruction as may be necessary to provide a safe water supply.

(c) Constructed in such manner as to maintain natural protection against contamination of water bearing formations and to exclude known sources of contamination.

(3) **PUMP INSTALLATION.** The installation of the pumping equipment shall be:

(a) Located in such manner that the pump and its surroundings can be kept in a sanitary condition,

(b) Adequate in capacity to supply the required volume of water, where available for maintenance of sanitary conditions, all ordinary domestic purposes and other specified uses. (See section RD 12.03 (1)).

(c) Designed to meet the well characteristics, durable in character and made in such manner that continued operation without priming is assured at time of installation.

(d) Made in such manner as to provide adequate protection against contamination of any character from any surface or subsurface source.

History: 1-2-56; renum. from H 55.02 to be RD 12.02, and am., Register, June, 1967, No. 138, eff. 7-1-67; am. (1), Register, February, 1968, No. 146, eff. 3-1-68.

RD 12.03 Definitions. For the purpose of these regulations the following definitions are established:

(1) **ADEQUATE WATER SUPPLY** means that, where obtainable, the yield of a well or the capacity of a pump and distribution system shall be sufficient to meet the requirements which the user has stated are necessary for drinking, culinary, food processing and other purposes for which well water is intended to be used.

(2) **ANNULAR SPACE** means the space between 2 circular objects, one of which surrounds the other, such as the opening between a drill-hole and a casing pipe or between a casing pipe and a liner pipe.

(3) **APPROVED** means sanctioned by the department of resource development in conformity with applicable laws, regulations and specifications.

(4) **CONTAMINATION** means any matter which will render water unsafe for human consumption.

(5) **DRAWDOWN** means the extent of lowering of the water level in a well when water flows or is pumped from it.

(6) **DRILLHOLE.** (a) **Lower drillhole** means that part of a drillhole below the vertical zone of contamination.

(b) Upper drillhole means that part of a drillhole, augerhole or excavation established through the vertical zone of contamination.

(7) DRIVEN POINT WELL means a well constructed by joining a "drive point" with a length of pipe, extended as may be necessary, and driving the assembly into the ground without preliminary excavation in excess of 10 feet depth. So called "tubular" type wells are considered drilled type wells.

(8) ESTABLISHED GRADE means the permanent point of contact of the ground or artificial surface with the casing pipe or curbing of the well.

(9) ESTABLISHED GROUND SURFACE means the permanent elevation of the surface of the site of the well.

(10) FLUSHING means the act of causing a rapid flow of water from a well by pumping, bailing or similar operation.

(11) NEAR-SURFACE WATER means water in the zone immediately below the ground surface. It may include seepage from barnyards, leaching pools and disposal beds or leakage from sewers, drains and similar sources of contaminated water.

(12) PREPARATION OF FOOD PRODUCTS means washing, cooling, cooking, pasteurizing, bottling, canning, or otherwise preparing food for human consumption, and including the washing of utensils and equipment used in production or preparation of food.

(13) PRIVATE WATER SUPPLY means one or more sources of ground water, including facilities for conveyance thereof, such as wells, springs and pumps, on one property, other than those serving a municipality or a group of 10 or more premises of mixed ownership.

(14) PUMPING WATER LEVEL means that elevation of the surface of the water in a well when water flows or is pumped from it at the customary rate.

(15) SAFE WATER means water that is free from contaminating matter.

(16) SANITARY CONDITION. (a) When referring to a well it means that the construction of the well and the installation of the pumping equipment are such that the well is effectively protected against entrance of contaminating matter.

(b) When referring to the surroundings of a well it means that the location and surrounding area are free from debris or filth of any character and not subject to flooding.

(17) SEWER means a conduit used or intended for conveying sewage.

(18) SPECIFIC CAPACITY means the continuous yield of a well at a given drawdown expressed in gallons per minute, per foot of drawdown.

(19) STATIC WATER LEVEL means that elevation of the surface of the water in a well when no water flows or is being pumped therefrom.

(20) STOCK WATERING WELL means a well used to supply water for farm animals and agricultural purposes, water from which is not used in the production or preparation of food or food products for human consumption.

(21) **STUFFING BOX** means an approved receptacle in which packing may be compressed to form a water or airtight junction between 2 objects.

(22) **VERTICAL ZONE OF CONTAMINATION** means that depth of near-surface formations containing connecting pore spaces, crevices or similar openings, including artificial channels, such as unprotected wells, through which contaminated water may gain access to a well or the ground-water body.

(23) **WATER-TIGHT CONSTRUCTION** implies cased and grouted construction through firm formations like clay or rock. Through granular material like sand or gravel, it implies that the casing pipe is of approved quality and assembled water-tight.

(24) **WELL SEAL** means an approved removable arrangement or device used to cap a well or to establish and maintain a junction between the casing or curbing of a well and the piping or equipment installed therein, so as to prevent water from entering the well at the upper terminal.

(25) **WELL VENT** means an outlet at the upper end of the well casing to allow equalization of air pressure in the well.

(26) **YIELD** means the quantity of water per unit of time, which may flow or be pumped from a well.

(Note: For definitions of department, ground water, permit, well, well driller, well drilling, see chapter 162, Wis. Stats.)

History: 1-2-56; renum. from H 55.03 to be RD 12.03, and am., Register, June, 1967, No. 138, eff. 7-1-67; am. (21), Register, February, 1968, No. 146, eff. 3-1-68.

RD 12.04 Location. (1) **GENERAL.** Every well shall be located in keeping with the following principles:

(a) At the highest point in the premises consistent with general layout and surroundings, but in any case protected against surface wash.

(b) As far removed from any known or probable source of contamination as the general layout of the premises and the surroundings permit.

(2) **RELATION TO POLLUTION SOURCES.** Minimum distances between wells and sources of contamination shall be maintained as follows:

(a) Seepage pit, filter bed, soil absorption field or similar sewage disposal unit—50 feet.

(b) Water-tight grease trap, septic tank or tile sewer—25 feet.

(c) Cast iron sewer having leaded joints—8 feet.

(d) Sewer-connected foundation drain—15 feet.

(e) Independent clear water drain, downspout, cistern or similar unit—10 feet.

(3) **RELATION TO BUILDINGS.** With respect to buildings the location of a well shall be as follows:

(a) When a well is located adjacent to a building, it shall be located so that the center line of the well extended vertically will clear any projection from the building by not less than 2 feet.

(b) Every well shall be located so that it will be reasonably accessible with proper equipment for cleaning, treatment, repair, test, inspection, and such other attention as may be necessary.

(c) No well shall be located so that the top thereof will be within the basement of any building nor under a building having no basement.

History: 1-2-56; renum. from H 55.04 to be RD 12.04, Register, June, 1967, No. 138, eff. 7-1-67.

RD 12.05
RD 12.05 Design and construction. (1) **GENERAL.** The construction of every well shall be planned and carried out so that it is:

(a) Adapted to the geologic (earth structure) and ground water conditions existing at the site of the well so as to insure full utilization of every natural protection afforded thereby.

(b) Designed to facilitate such supplementary construction as may be required to provide a sufficient and safe water supply, where obtainable, and to conserve ground water.

(c) Capable of yielding, where obtainable, the quantity of water required to satisfy the requirements which the user has stated are necessary and for which well water is intended to be used.

(2) **DRILLED TYPE WELLS.** The foregoing requirements shall be deemed to be fulfilled to the minimum extent when a drilled well has been installed in conformity with the applicable construction set forth in table 1. (See Appendix figures 1, 2, 3, 4, 5.)

Handwritten notes:
 11/2, 05
 11/2, 05
 11/2, 05
 11/2, 05

Table 1
DRILLED TYPE WELL REQUIREMENTS

| No. | Water-Bearing Formation | Overlying Material | Drillhole | | | Well Pipe | | Construction Conditions |
|-----|---------------------------------|---|-------------------------|--|-----------------|-----------------|---|--|
| | | | Upper | | Lower Diameter | Casing Diameter | Liner Diameter | |
| | | | Diameter | Depth | | | | |
| a. | Sand or Gravel | Sand or mixture of sand and gravel. | | | Same as casing. | Minimum 2" | | a, b, c. An adequate screen shall be provided where necessary. They shall be installed in such a manner that removal or replacement can be accomplished without adversely affecting the water-tight construction of the well. |
| b. | Sand or Gravel | Clay or similar material to depth of 30' or more, containing layers of sand or gravel. | Casing diameter plus 4" | 5' into clay below any sand or gravel above the 20' depth. | Same as casing. | Minimum 2" | The casing shall extend 5' below the pumping level. The annular space shall be grouted with cement slurry. | |
| c. | Sand or Gravel | Clay or similar material only to depth of 25' or more. | Casing diameter plus 4" | Minimum 20' | Same as casing. | Minimum 2" | The casing shall extend 5' below the pumping level. The upper drillhole shall be kept about 1/2 filled with clay slurry throughout driving of permanent well casing. The balance of the annular space shall be filled with clay slurry or cement grout. | |
| d. | Limestone, Granite or Quartzite | Drift, mainly sand or gravel, to depth of at least 40' to a radius of 1/2 mile. No record of sink holes, test holes or abandoned wells in above area. | | | 6" | Minimum 6" | Minimum 4" | d, e. The casing pipe shall be firmly seated in the rock formation. Liner pipe 2" smaller than casing pipe or drillhole shall be assembled without couplings. |
| e. | Limestone, Granite or Quartzite | Clay or similar material to depth of at least 40' to a radius of 1/2 mile. No record of sink holes, test holes or abandoned wells in above area. | Casing diameter plus 4" | Minimum 20' | 6" | Minimum 6" | Minimum 4" | |

Table 1—Continued
DRILLED TYPE WELL REQUIREMENTS

| No. | Water-Bearing Formation | Overlying Material | Drillhole | | Well Pipe | | Construction Conditions | |
|-----|---------------------------------|---|-------------------------|--|----------------|-----------------|-------------------------|---|
| | | | Upper | | Lower Diameter | Casing Diameter | | Liner Diameter |
| | | | Diameter | Depth | | | | |
| f. | Limestone, Granite or Quartzite | Drift material for depth less than 40' within a radius of ½ mile. No record of sink holes, test holes or abandoned wells in above area. | Casing diameter plus 4" | 10' into unreveiled rock below 30' | 6" | Minimum 6" | Minimum 4" | f, g, h. Neat cement grout shall be used. When grout material is placed by a suitable pump from the bottom of the casing the upper drillhole diameter need be only 2" larger than the casing pipe. Liner pipe 2" smaller than casing pipe or drillhole shall be assembled without couplings. |
| g. | Sandstone | Any material except limestone to depth of 20' or less. | Casing diameter plus 4" | 15' into firm sandstone or to 30' depth. | 4" | Minimum 4" | Minimum 2" | g, h. The casing pipe shall be effectively seated into sandstone. |
| h. | Sandstone | Any material except limestone to depth of 21 to 25'. | Casing diameter plus 4" | Into firm sandstone. Minimum depth 30'. | 4" | Minimum 4" | Minimum 2" | |
| i. | Sandstone | Mixed deposits mainly sand and gravel to depth of 25' or more. | | Into firm sandstone | 4" | Minimum 4" | Minimum 2" | i, j. The casing pipe shall be effectively seated into sandstone. Liner pipe 2" smaller than casing pipe or drillhole shall be assembled without couplings. |
| j. | Sandstone | Clay or similar material to depth of 25' or more. | Casing diameter plus 4" | Minimum 20' | 4" | Minimum 4" | Minimum 2" | The upper drillhole shall be kept about ½ filled with clay slurry throughout driving of permanent well casing. The balance of the annular space shall be filled with clay slurry or cement grout. |
| k. | Sandstone | Limestone at variable depth. | Casing diameter plus 4" | Minimum 15' into firm sandstone. | 6" | Minimum 6" | Minimum 4" | The annular space shall be filled with cement grout. When grout material is placed by a suitable pump from the bottom of the casing the upper drillhole diameter need be only 2" larger than the casing pipe. |

Register, September, 1970, No. 177
Environmental Protection

(a) Well casing pipe. The minimum standard of quality for casing material through the vertical zone of contamination shall be steel or wrought iron pipe having weights as specified in table 2.

Table 2
CASING PIPE WEIGHTS AND DIMENSIONS

| Size in Inches | Wt. Lbs. Per Ft. Threads and Couplings | Pipe | | | Threads Per Inch | Couplings | |
|-----------------|--|---------------------|-----------------|----------|------------------|------------------|--------------------------|
| | | Thickness in Inches | Diameter-Inches | | | Length in Inches | External Diameter Inches |
| | | | External | Internal | | | |
| 1 | 1.68 | .133 | 1.315 | 1.049 | 11 $\frac{1}{2}$ | 1 $\frac{7}{8}$ | 1.556 |
| 1 $\frac{1}{4}$ | 2.23 | .140 | 1.660 | 1.380 | 11 $\frac{1}{2}$ | 2 $\frac{1}{8}$ | 1.907 |
| 1 $\frac{1}{2}$ | 2.73 | .145 | 1.900 | 1.610 | 11 $\frac{1}{2}$ | 2 $\frac{3}{8}$ | 2.218 |
| 2 | 3.68 | .154 | 2.375 | 2.067 | 11 $\frac{1}{2}$ | 2 $\frac{5}{8}$ | 2.760 |
| 2 $\frac{1}{2}$ | 5.82 | .208 | 2.875 | 2.469 | 8 | 2 $\frac{7}{8}$ | 3.276 |
| 3 | 7.62 | .216 | 3.500 | 3.068 | 8 | 3 $\frac{1}{8}$ | 3.948 |
| 3 $\frac{1}{2}$ | 9.20 | .226 | 4.000 | 3.548 | 8 | 3 $\frac{5}{8}$ | 4.591 |
| 4 | 10.89 | .237 | 4.500 | 4.026 | 8 | 3 $\frac{5}{8}$ | 5.091 |
| 4 $\frac{1}{2}$ | 12.64 | .247 | 5.000 | 4.506 | 8 | 4 $\frac{1}{8}$ | 5.591 |
| 5 | 14.81 | .258 | 5.563 | 5.047 | 8 | 4 $\frac{1}{8}$ | 6.296 |
| 6 | 19.18 | .280 | 6.625 | 6.065 | 8 | 4 $\frac{1}{8}$ | 7.358 |
| 7 | 23.769 | .301 | 7.625 | 7.023 | 8 | 4 $\frac{1}{8}$ | 8.358 |
| 8 | 25.00 | .277 | 8.625 | 8.071 | 8 | 4 $\frac{5}{8}$ | 9.420 |
| 10 | 35.00 | .307 | 10.750 | 10.136 | 8 | 6 $\frac{1}{8}$ | 11.721 |
| 12 | 45.00 | .330 | 12.750 | 12.090 | 8 | 6 $\frac{1}{8}$ | 13.958 |
| 14 OD | 57.00 | .375 | 14.000 | 13.250 | 8 | 7 $\frac{1}{8}$ | 15.446 |
| 15 OD | 61.15 | .375 | 15.000 | 14.250 | 8 | 7 $\frac{1}{8}$ | 16.446 |
| 16 OD | 65.30 | .375 | 16.000 | 15.250 | 8 | 7 $\frac{1}{8}$ | 17.446 |
| 17 OD | 73.20 | .375 | 17.000 | 16.250 | 8 | 7 $\frac{1}{8}$ | 18.683 |
| 18 OD | 81.20 | .375 | 18.000 | 17.250 | 8 | 7 $\frac{1}{8}$ | 19.921 |
| 20 OD | 90.00 | .375 | 20.000 | 19.250 | 8 | 7 $\frac{5}{8}$ | 21.706 |

(b) Well casing pipe shall be assembled water-tight by means of joints welded in accordance with approved practice or by correctly mated, standard weight couplings.

(c) Well casing pipe shall be driven or installed so that no injury affecting the safety of the water supply results.

(d) No second hand or reclaimed pipe shall be used as the protective casing in the permanent construction of a well.

(3) FLOWING WELLS. The construction of flowing wells shall comply with the minimum requirements of RD 12.05 (2).

(a) Every practicable effort shall be made to extend the water-tight (cased and cement grouted) construction into the upper confining bed of the artesian basin.

(b) When it is impractical to extend the water-tight construction as indicated in subsection (a), an adequate packer shall be set and maintained in the confining bed with a flowpipe extending therefrom to a point at least one foot above the established grade.

(Note: Owners of flowing wells can contribute substantially to the conservation of their artesian ground-water supply by maintaining their wells in good repair and controlling the flow therefrom within the limits of their actual needs.)

(4) BORED TYPE WELLS. Through the vertical zone of contamination the construction of a bored type well shall conform to the specifications for drilled type wells. (Section RD 12.05 (2) and Appendix figure 6.)

(a) The minimum diameter of the casing pipe shall be 6 inches.

(b) The curbing below the vertical zone of contamination shall be properly cured concrete pipe or equal. In such case the joints shall be the tongue and groove type. Plain end or bell and spigot pipe shall not be used.

(c) The minimum inside diameter of well curbing shall be 8 inches.

(Note: By placing a short length of casing pipe concentrically within a section of curbing pipe and filling the resulting annular space with rich concrete, a very satisfactory junction is obtained between the casing and curbing pipe.)

(5) **DRIVEN POINT WELLS.** Through the vertical zone of contamination the depth of the unperforated pipe of a driven point well shall conform to the specifications for drilled type wells. (See section RD 12.05 (2)).

(a) The depth of a driven point well shall be sufficient to prevent breaking suction when pumping the well at a rate of 50% greater than the capacity of the permanent pump.

(b) Protection against freezing shall be accomplished by means of casing pipe. So-called "frost-pits" curbed with stones, brick, tile, wood and the like are prohibited. (See Appendix figure 7.)

(6) **DUG TYPE WELLS.** The retaining wall of every dug type well shall be substantial and water-tight to a depth of at least 2 feet below the vertical zone of contamination but in no case less than 12 feet below the established grade at the well. The curbing through the intake area shall be of adequate strength to withstand any external pressure to which it may be subjected and must be seated sufficiently firm to prevent settling.

(a) *Concrete wall.* The concrete mixture shall conform with the provisions of section RD 12.11 (1). The wall shall be circular and at least 6 inches thick with concrete so placed as to be free from voids. Vertical and horizontal reinforcing with three-eighths inch rods on 12-inch centers shall be provided. Rods shall lap 12 inches but such lap shall not occur at construction joints. If possible, the wall shall be poured in one operation but in no case shall there be a construction joint within 10 feet of the surface. Construction joints shall be left rough and shall be washed and brushed with neat cement grout before pouring of concrete is continued. (See Appendix figure 8 (a).)

(b) *Metal wall.* A metal retaining wall of steel or wrought iron shall be at least three-sixteenths of an inch thick, with welded joints. The wall shall be sufficiently thick and so reinforced as to resist any external pressure to which it may be subjected.

(c) *Casing pipe reduction.* In lieu of extending well curbing of full dug well diameter to the surface, a standard weight steel or wrought iron pipe at least 6 inches in diameter may be used. This pipe shall be firmly seated in a reinforced concrete slab which shall be mounted on the full diameter curbing. Such slab shall be located so that the top is at least 12 feet below the established grade at the well. If the vertical zone of contamination extends below a depth of 12 feet, the casing pipe or water-tight curbing shall extend to any additional depth necessary. (See figure Appendix 8 (b).)

(d) *Curbing installation.* In caving soil formation, the curbing shall be constructed at the surface and carried down by excavating from the interior. If wood forms are used on the exterior of the wall, they shall be removed before the wall is lowered. Use of exterior wood forms below the ground surface is prohibited. Metal forms may be left in place.

(e) *Annular opening.* The opening between the face of the excavation and curbing or casing through the vertical zone of contamination shall be filled with clean puddled clay or equal.

(f) *Upper terminal.* Except when a dug well is constructed in accordance with subsection (c), the curbing shall extend at least 8 inches above an established free draining grade, and the ground graded up around same to a height of 6 inches, above the ground so as to conduct all surface water away from the well.

(g) *Dug well cover.* The cover of a well curbed according to subsection (a) or (b) shall be made of substantial reinforced water-tight concrete at least 5 inches thick and of sufficient diameter to overlap the wall or curb by at least 2 inches. The cover shall be free from joints. A tight joint shall be provided between the top of the wall and the cover, using a plastic compound, if necessary. The top of the slab shall be sloped to drain away from the pump. A manhole, if installed, shall be provided with a metal curb, the top of which extends 4 inches above the slab and is equipped with an overlapping cover, the sides of which extend downward at least one and one-half inches. The manhole cover shall be locked or bolted in place in such manner as to be safe and to prevent entrance of water. (See section RD 12.09 (1).)

(h) *Equipment location.* No pumping equipment or appurtenances requiring access to the interior of the well for maintenance or repair operations shall be installed in the well.

(7) **DEEPENING DUG TYPE WELLS.** A drilled type well may be constructed through an existing dug type well in accordance with the following procedures:

(a) *Preparation for deepening.* Any sediment or debris in the bottom of the dug well shall be removed. The bottom shall be disinfected by distributing a chlorine solution over the bottom or mixing such solution to water in the well. A concentration of 200 parts per million of chlorine should be attained for disinfection.

(b) *Applicability to drilled type construction.* Deepening construction done by drilling methods shall conform to applicable conditions of subsection (2) (See Appendix figure 9.)

(Note: Existing "dug and drilled" type wells can be effectively protected against entrance of surface and near-surface water by extending the casing pipe of the drilled part of the well to the surface and filling the dug part of the well with puddled clay or equally impermeable material.)

History: 1-2-56; renum. from H 55.05 to be RD 12.05, Register, June, 1967, No. 133, eff. 7-1-67.

RD-12.06 Surface protection. (1) The water-tight casing or curbing of any well supplying water used in production or preparation of food or food products or supplying water to premises serving the public shall extend to a point above the established ground surface. A sub-surface pipe connection to such a well shall not be allowed, unless it is made with an approved threaded fitting, the connection is above ground-water level, the piping is under pressure and no pit is required. On off-set installations in basements, the pump impeller or cylinder shall be located at an elevation above the ground surface or at a height of 2 or more feet above the basement floor. Pressure conduits may terminate at the end of the horizontal line entering the basement if the point of entrance is 2 feet or more above a basement floor that is in active use. Exceptions to this section may be

made only where a permit for a well pit has been obtained from the department. Such a permit shall be granted where the plans and specifications submitted for the construction of the pit and the pump installation assure a reasonably safe water supply.

(2) The water-tight casing or curbing of any well supplying water to residential units housing not more than 3 families shall extend to a point above the established ground surface unless a permit for a well pit is obtained from the department. A pitless sub-surface connection is permitted if made with approved fittings or welding procedures, the connection is above ground-water level, and the pump location is not subject to flooding. Suction, submersible and jet pump piping shall be enclosed in a pipe conduit having a minimum thickness of 0.237 inches. (See section RD 12.09 (1)).

am
(2)

(Note: Application for a permit to install a well pit shall be made to the department.)

History: 1-2-56; renum. from H 55.06 to be RD 12.06, and am., Register, June, 1967, No. 138, eff. 7-1-67; am. (1) and (2), Register, February, 1968, No. 146, eff. 3-1-68.

RD 12.07 Miscellaneous well construction requirements. (1) ALIGNMENT. The deviation of the center line of a well of a drilled or bored type from a straight line per one hundred feet of depth shall not exceed the following tolerances to the depth of pump setting plus 25%. Diameter of curb in inches ----- 2 to 6 8 to 10 12 or more
Deviation based on diameter, % -- 100 75 50

am
112.07

For greater or lesser depths or for any given well length the allowable deviation shall be proportional.

(2) **CAVING PROTECTION.** When caving or sloughing formations that would interfere with the proper functioning of the well or the pumping equipment are encountered, entrance of foreign material shall be prevented by means of liner pipe, cementing or other approved methods.

(3) **FINISHING OPERATIONS.** Upon completing construction or reconstruction operations, the constructor of the well shall carry out finishing operations as follows:

(a) *Disinfection.* Disinfect the well in the manner prescribed by the department.

(Note: Adequate chlorination or other approved disinfection of all water used or present in the well during construction operations insures maximum effectiveness and reduces the time and effort involved in final disinfection to a minimum.)

(b) *Flushing.* Flush the well sufficiently to remove all traces of the disinfectant and to condition the well for use.

(c) *Testing.* Test the well by pumping, except when flowing in excess of requirements, to determine the amount of drawdown and the quantity and stability of the yield within the requirements of sections RD 12.02 (3) (b), RD 12.03 (1), RD 12.05 (1) (c) or if in excess thereof, as specified by agreement with the purchaser.

am
(3) (c) &
(d)

(d) *Sealing.* Seal the well water-tight. (See sections RD 12.09 (2) (a) and RD 12.09 (3).)

(Note: A properly fitted and firmly driven, solid wooden plug is considered the minimum acceptable method of sealing a well until the pumping equipment is installed.)

(4) **BLASTING.** The use of explosives for increasing or recovering yield of any well developed into limestone, granite or quartzite forma-

am
(4) &
(5)

tions, or of any sandstone well in which casings and liners are not grouted or in which the diameter of the drillhole is larger than that of casings or liners above the point of shooting, shall be undertaken only under permit from the department. (See section RD 12.08 (3).)

(5) **CHEMICAL CONDITIONING.** The use of dry ice, detergents, chlorine, acids, or other chemicals in wells for the purpose of increasing or restoring yield shall be undertaken only under permit from the department. Any chemical treatment of a well shall be under supervision of a registered well contractor, professional engineer, or qualified water superintendent. (See section RD 12.08 (3).)

History: 1-2-56; renum. from H 55.07 to be RD 12.07, and am., Register, June, 1967, No. 138, eff. 7-1-67; am. (3) (a) and (d), Register, February, 1968, No. 146, eff. 3-1-68.

RD 12.08 Samples and reports. (1) **WATER SAMPLES.** After flushing and testing a well and after completing installation of pumping equipment the constructor or installer shall collect one or more water samples from the well for bacteriological analysis. Such samples shall be submitted to the state laboratory of hygiene or one of its branch or cooperative laboratories.

(Note: If the well contractor installs the pumping equipment, submission of a sample upon completion of the pump installation will be satisfactory compliance. Where unforeseeable contamination is encountered the initial construction of a well will be considered complete if the construction conforms to these regulations.)

(2) **WELL CONSTRUCTION REPORTS TO DEPARTMENT.** Within 10 days after completing the construction or reconstruction of a well the constructor thereof shall submit a construction report to the department upon a form prescribed and furnished by the department.

(3) **WELL CONDITIONING REPORT TO DEPARTMENT.** Within 10 days after completing any well blasting or chemical treatment operation the contractor or supervisor shall submit a complete report as to methods used (unless covered in a permit application) and the results achieved.

(4) **REPORTS TO OWNERS.** The well constructor and pump installer shall report to the owner or his agent the laboratory analysis of the sample submitted at completion of the respective work. The well constructor shall also supply to the owner or his agent a copy of the well construction report at the time the report is made to the department.

History: 1-2-56; renum. from H 55.08 to be RD 12.08, and am., Register, June, 1967, No. 138, eff. 7-1-67.

RD 12.09 Pump installation and construction. (1) **UPPER WELL TERMINAL.** The casing pipe of any drilled, bored or driven type well and the pump installation pipe sleeve on any dug well shall project not less than 8 inches above the permanent established ground surface at the well, or 8 inches above a pump house floor, platform or cover installed above such established ground surface unless a permit for a subsurface terminal has been obtained.

(2) **HAND PUMP.** Every shallow well type hand pump and every deep well type hand pump head, stand or similar device shall be so constructed that no unprotected opening connecting with the interior of the pump exists. The spout shall be of the closed type.

(a) A hand pump shall be mounted firmly to the well casing pipe or pump mounting sleeve in such manner as to effectively seal the top of the casing or sleeve.

(3) **POWER DRIVEN PUMP.** Any power driven pump located over the well shall be mounted on the well casing, a pump foundation or a pump stand in such manner as to effectively seal the top of the well. In case the pump unit is not located over the well, and the pump delivery or suction pipe emerges from the top thereof, a water-tight expanding or equivalent seal shall be provided between the well casing and the piping. A similar seal shall be provided at the terminal of a conduit containing suction, submersible or jet pump piping. (See sections RD 12.06 (1) (2) and RD 12.09 (4).)

(Note: On the above ground pump installations the extension of the well casing at least one inch into the pump base will be considered an effective seal provided the pump base is mounted on a base plate or foundation in such manner as to exclude entrance of insects into the well and the elevation at the top of the well is at least 2 feet above any known flood water level.)

(a) **Pumphouse.** The structure housing a power driven pump shall be constructed so as to permit access to the pump for maintenance and repair work. The pumphouse floor shall be constructed of concrete. On above ground installations the surface thereof shall be located not less than 4 inches above the established ground surface. (See section RD 12.06 (2).)

(b) **Protection against freezing.** The pump, discharge line and accessory equipment shall be protected against freezing by insulation of structure and piping and installation of dependable heating facilities, preferably of a thermostatically controlled type.

(4) **WELL VENT.** Any well vent opening shall be piped watertight to a point not less than 24 inches above any known flood water level but at least 12 inches above the top of the well. Such vent opening and extension thereof shall be not less than one-quarter inch in diameter, the extension pipe to be firmly attached. The terminal of the vent pipe shall be shielded and screened so as to prevent entrance of foreign matter. Any opening in a pump base shall be sealed water-tight.

(5) **SAMPLING FAUCET.** In all pressure water systems provision shall be made for collection of water samples by installation of a faucet or pet cock on the discharge side of the pump.

(6) **CASING NOT PART OF PUMP INSTALLATION.** In areas where ground water is known to be corrosive, no pipe serving as the casing of any well shall be used as a delivery pipe or be utilized in the pumping operation. Moving pump parts located in any well shall be enclosed.

(7) **DISINFECTION AND SAMPLING.** Upon completing the installation of pumping equipment, the installer thereof shall conform to sections RD 12.07 (3) (a) (b) and RD 12.08 (1) (4).

History: 1-2-56; renum. from H 55.09 to be RD 12.09, Register, June, 1967, No. 138, eff. 7-1-67.

RD 12.10 Well construction equipment. (1) **ADEQUACY.** Every registered well constructor shall be adequately equipped or shall have unquestionable access to adequate equipment to enable full compliance with all regulatory requirements applicable to any construction undertaken by him.

(2) **IDENTIFICATION.** The well constructor's name and current permit number shall be conspicuously displayed on every well construction job, preferably on his equipment.

History: 1-2-56; renum. from H 55.10 to be RD 12.10, Register, June, 1967, No. 138, eff. 7-1-67.

(3/2/70)
+
(a)
am
Mary
Reg
7/11/75

am
NR
112.10

an
112.11

RD 12.11 Concrete and grout mixtures. (1) **CONCRETE AGGREGATE AND MIXTURE.** Concrete for use in construction of wells, well platforms and pump floors shall be made of clean, hard, tough and durable aggregates. The maximum diameter of aggregate particles shall not exceed one-fifth of the minimum width between forms. The fine aggregate, or sand, should be separated from the coarse aggregate by means of one-fourth inch screen, the ratio of coarse aggregate to fine aggregate shall be about one and one-half to one, by volume. This ratio shall not exceed 2 to one nor be less than one to 2. From 30 to 70 per cent of the sand passing a one-fourth inch screen should be retained on a number 30 sieve. In proportioning concrete, sufficient sand and coarse aggregate shall be mixed to make approximately 3 cubic feet of mixed aggregate. To this aggregate shall be added one sack of cement and five and one-half gallons of water. If the aggregate is wet, the water ratio shall be 5 gallons per sack of cement. The consistency shall be wet enough to permit easy placement without an excess of water.

(2) **CONCRETE GROUT.** The mixture shall consist of cement, sand and water in the proportion of one bag of cement (94 pounds), and an equal volume of dry sand, and 5 to 6 gallons of clean water.

(3) **NEAT CEMENT GROUT.** The mixture shall consist of cement and water in the proportion of one bag of cement (94 pounds) to 5 to 6 gallons of clean water. Approved ingredients to increase fluidity, reduce shrinkage or control time of set may be used in a grout mixture.

History: 1-2-56; renum. from H 55.11 to be RD 12.11, Register, June, 1967, No. 138, eff. 7-1-67.

an
12.12

RD 12.12 Use of wells for drainage purposes. (1) **DRAINAGE WELLS PROHIBITED.** The use of any well for disposal of sewage or other drainage, other than shallow leaching pools installed under governing regulations, is prohibited. (See Wis. Adm. Code section H 62.20. Wisconsin plumbing code.)

History: 1-2-56; renum. from H 55.12 to be RD 12.12, Register, June, 1967, No. 138, eff. 7-1-67.

an
12.13

RD 12.13 Abandonment of wells. (1) **METHODS.** When a well is permanently abandoned, the owner thereof shall fill and seal the well in such manner as to prevent it from acting as a channel for contamination or vertical movement of water by one of the following methods:

(a) *Drift formations.* Fill with clean puddled clay or concrete.

(b) *Limestone formation.* Fill any limestone strata with concrete or alternate layers of concrete and gravel or stone aggregate capping with a layer of concrete 20 feet deep at the top of formation.

(c) *Sandstone formation.* Fill any sandstone formations with concrete or with sand capped with layer of concrete at least 20 feet in depth at top of formation.

(d) *Mixed formation wells.* Fill limestone and sandstone strata in compliance with preceding sections, providing concrete plugs 20 feet in depth, at the top of every recognized geologic formation.

(e) *Flowing wells.* Confine flow and fill well in accord with preceding sections or seal by pressure cementing.

(f) *Obstructions.* Any debris or obstructions that may interfere with sealing operations shall be removed from well to be abandoned.

(2) TEMPORARY ABANDONMENT. When a well is temporarily removed from service the top shall be sealed with a water-tight threaded or welded cap or it shall be filled with clean puddled clay.

(3) REPORT TO DEPARTMENT. A report shall be made to the department by the owner of every well which has been abandoned or temporarily removed from service. Such report shall include a detailed description of location, construction and geologic features, and method of sealing.

History: 1-2-56; renum. from H 55.13 to be RD 12.13, and am., Register, June, 1967, No. 138, eff. 7-1-67.

RD 12.14 Orders. (1) GENERAL. The director may, upon receiving written notice of any alleged failure on the part of any well constructor or installer of pumping equipment to observe and comply with any rule or regulations of this code, order any such constructor or installer to give at least 48 hours notice to the department of the day and date upon which any well under construction or any installation of the pumping equipment, by such constructor or installer, or any employe or agent thereof, will be completed; and, require any such constructor or installer to assist the supervisor of well construction in ascertaining the size, depth and character of the construction of any such well or the character of the samples of water from any such well, and such other information as may be required by the said supervisor to determine if any such well has been constructed or any such equipment has been installed in accordance with the rules and regulations of this code. The aforesaid order shall remain in effect for such time as in the discretion of the department may be deemed necessary to attain full compliance with the rules and regulations of this code and until terminated by written notice issued by the said officer.

am NR
12.14
d
am

History: 1-2-56; renum. from H 55.14 to be RD 12.14, and am., Register, June, 1967, No. 138, eff. 7-1-67.

RD 12.15 Existing installations. (1) LOCATION AND CONSTRUCTION. Each existing water supply system shall be viewed as an individual unit and its safety shall be interpreted on basis of location and construction.

NR 12.15
(a) +
(b) (1) (2)

(a) *Location.* The location shall reasonably conform to Wis. Adm. Code section RD 12.04.

(b) *Construction.* The underground construction shall be in reasonable compliance with section RD 12.05 as to depth and type of casing and curbing. Existing well pit installations shall meet the following requirements.

1. The floor and roof of any well pit shall be crack-free poured concrete having a thickness of at least 4 inches. The walls of the pit shall be 6-inch thick poured concrete or equivalent construction unless the pit is provided with an independent drain discharging by gravity to the ground surface at an elevation not subject to flooding or gives a history of being continuously dry in which case masonry walls of cement block, brick or stone shall be acceptable. A 3-inch thick concrete facing on substantial masonry walls shall be accepted as equivalent wall construction. The junction of walls and floors shall be water-tight. The pit roof or deck shall be above the ground surface.

2. The well pit shall be fitted with a manhole opening having a raised curbing edge at least 3 inches higher than the pit roof. A sub-

stantial, water-tight, overlapping, tight-fitting cover with skirted sides shall be provided for the manhole.

3. Where practical the well pit shall be drained by a separate gravity type drain discharging to the ground surface or to a seepage point above ground-water level and be laid water-tight from the pit to a point at least 10 feet from the pit, such drain being constructed either with steel or with cast iron pipe. When such a drain is not installed, a water-tight sump shall be provided, except that where ground water gains access to the pit an automatic sump pump shall also be required. A pump room adjoining a basement may be drained to the basement provided the basement in turn is adequately drained. No pit drain or sump pump discharge pipe shall be connected directly with any other sewer, drain, or plumbing system.

4. The well casing shall terminate at least 6 inches above the pit floor and be provided with a sanitary expanding type well seal.

5. Well pits should preferably be vented by use of two 2-inch galvanized steel pipes located in opposite corners, one pipe to extend to within one foot of the pit floor and the other to extend only through the pit roof. The upper end of the vent pipes should terminate with return bends.

(2) **PUMP INSTALLATION.** Existing pump installations shall conform to the following requirements:

(a) *Offset units.* The suction line of an offset shallow well pump or the piping of an offset jet pump shall be contained in a sealed conduit between the well and a basement, be connected to the well through a stuffing box or short sealed conduit in a conforming well pit, or be connected to the well with a pitless adapter. It is recommended that the pump impeller or cylinder of pump units located in basements be located above the ground level or be at least 3 feet above the floor.

(b) *Pit setting.* A deep well reciprocating, turbine or jet pump and set-length type force pump located in a conforming pit shall be so installed as to permit the sealing of the top of the well with an approved type seal. Any well vent pipe shall extend to the top of the pit and terminate with a return bend.

(c) *Hand type pumps.* Hand type pumps may be continued in service provided that the pump base flange rests upon a casing flange and the flanges are separated by a gasket. The casing flange must be placed at least 6 inches above the ground or a concrete pump platform. If water is pumped from a hand pump to a reservoir, the piping attachment to the pump should be a closed system.

History: 1-2-56; renum. from H 55.15 to be RD 12.15, Register, June, 1967, No. 138, eff. 7-1-67.

Appendix

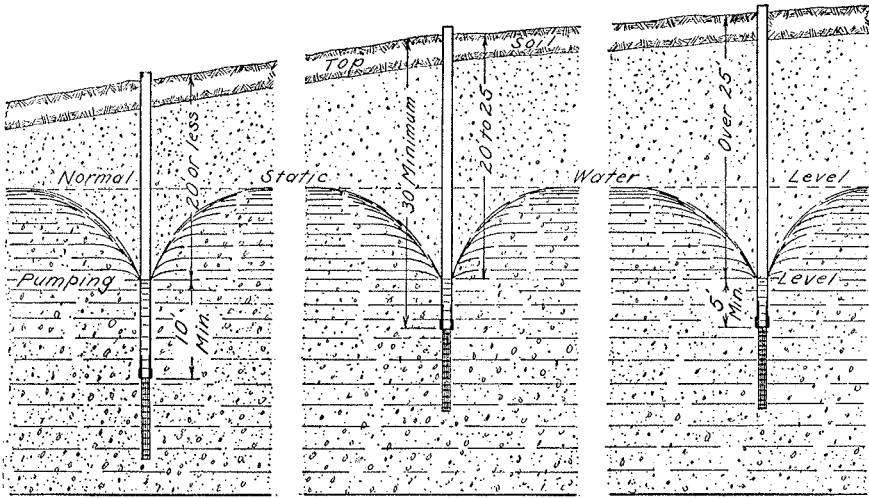

Figure 1. Construction of Wells in Sand and Gravel. See Table 1. a.

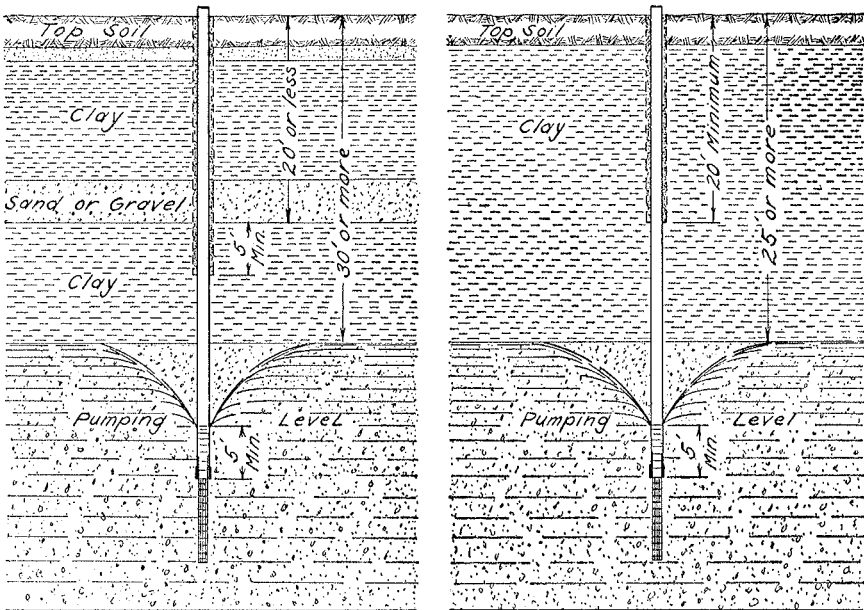

Figure 2. Construction of Wells Terminating in Sand and Gravel Underlying Clay. See Table 1, b and c.

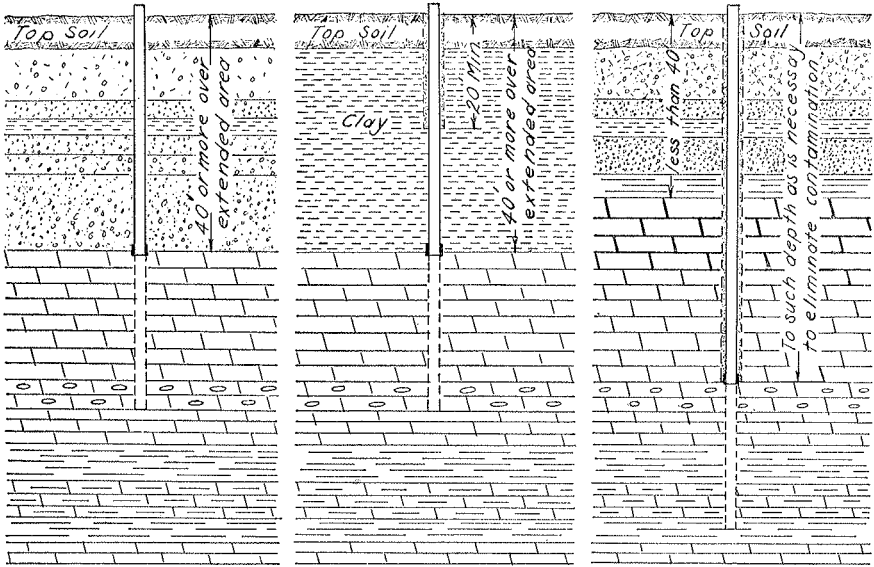

Figure 3. Construction of Wells Terminating in Limestone, Granite, or Quartzite. See Table 1, d, e and f.

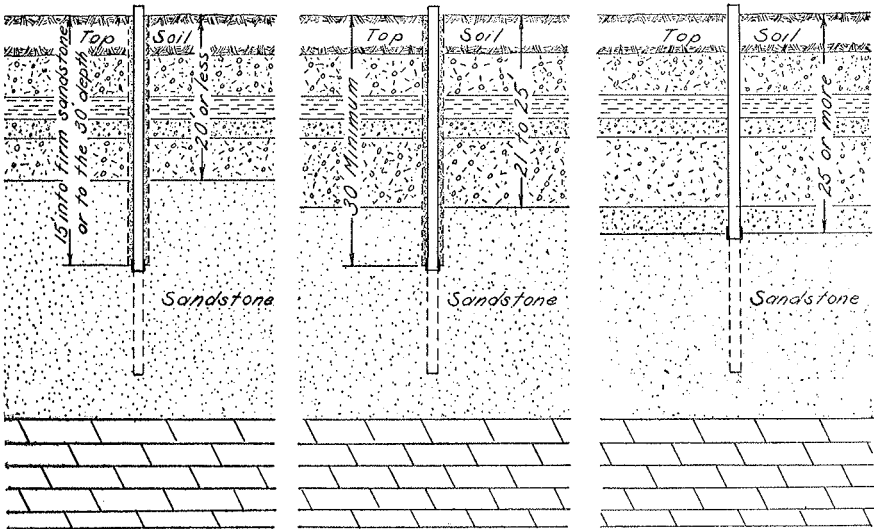

Figure 4. Construction of Wells Terminating in Sandstone Underlying Unconsolidated Material. See Table 1, g, h and i.

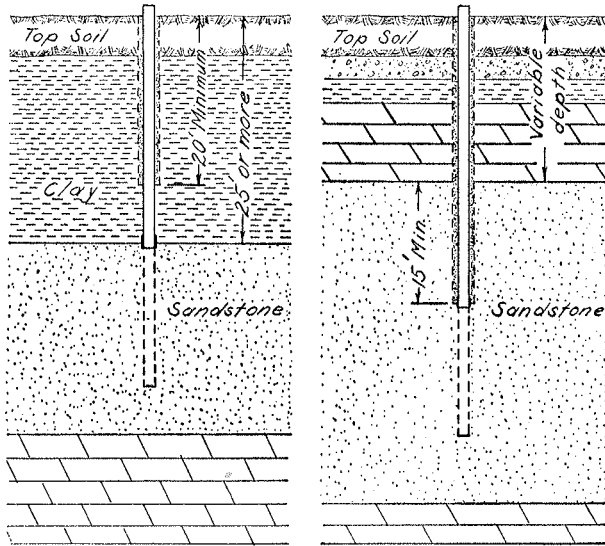

Figure 5. Construction of Wells Terminating in Sandstone Overlain with Clay or Limestone. See Table 1, j and k.

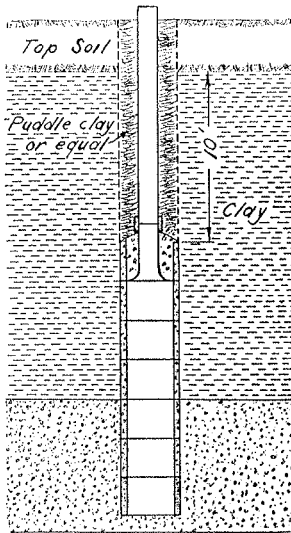

Figure 6. Bored Type Well Construction. See Wis. Adm. Code section RD 12.05 (4).

Handwritten signature: [unclear] May 1970

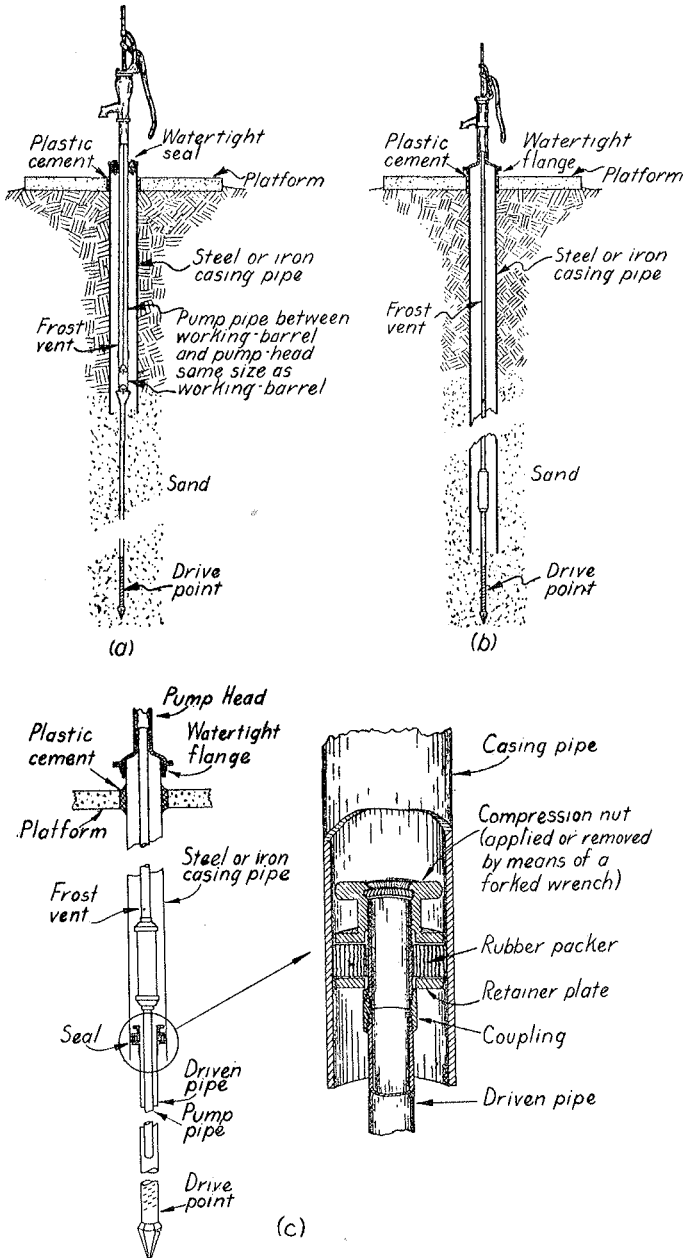

Figure 7. Driven Point Well Construction. Illustration (c) shows suitable method of returning frost drain water to well when impervious soil is present. See Wis. Adm. Code section RD 12.05 (5).

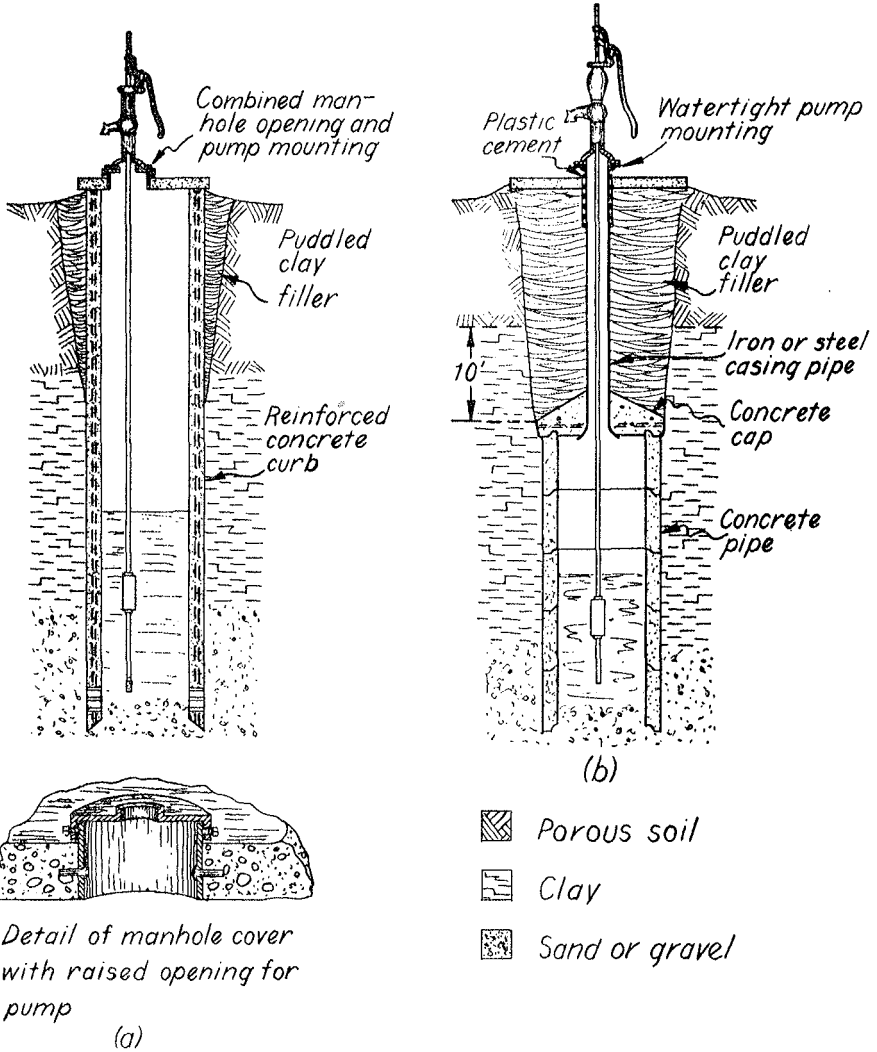

Figure 8. Sanitary Construction of Dug Wells. See Wis. Adm. Code Section RD 12.05 (6).

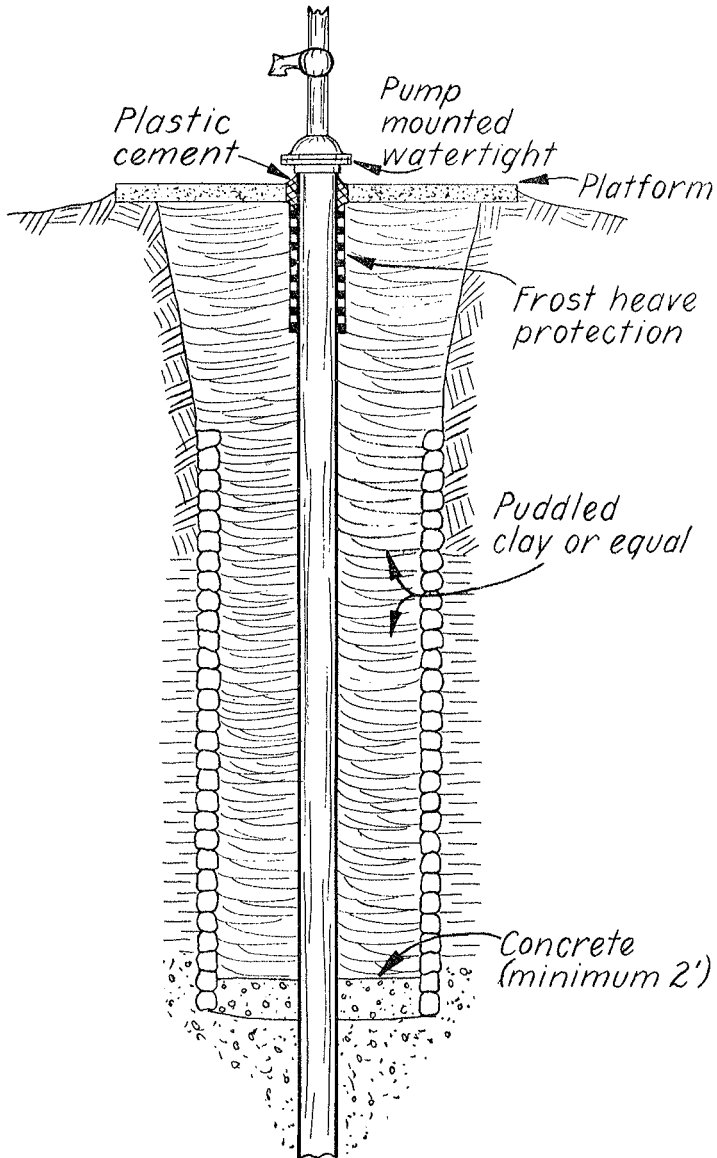

Figure 9. Drilled Well Constructed in Existing Dug Well. See Wis. Adm. Code section RD 12.05 (7).

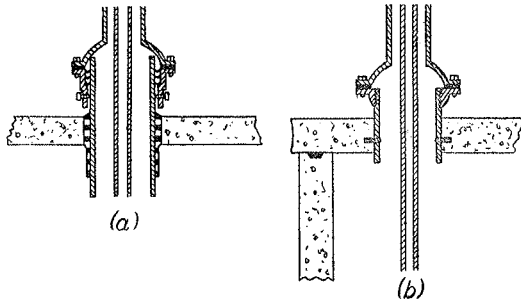

Figure 10. Hand Pump Mountings. (a) On well casing pipe through a water-tight pump flange. (b) On a section of pipe set in concrete well top and fitted with a pipe flange. See RD 12.09 (1) and (2) (a).

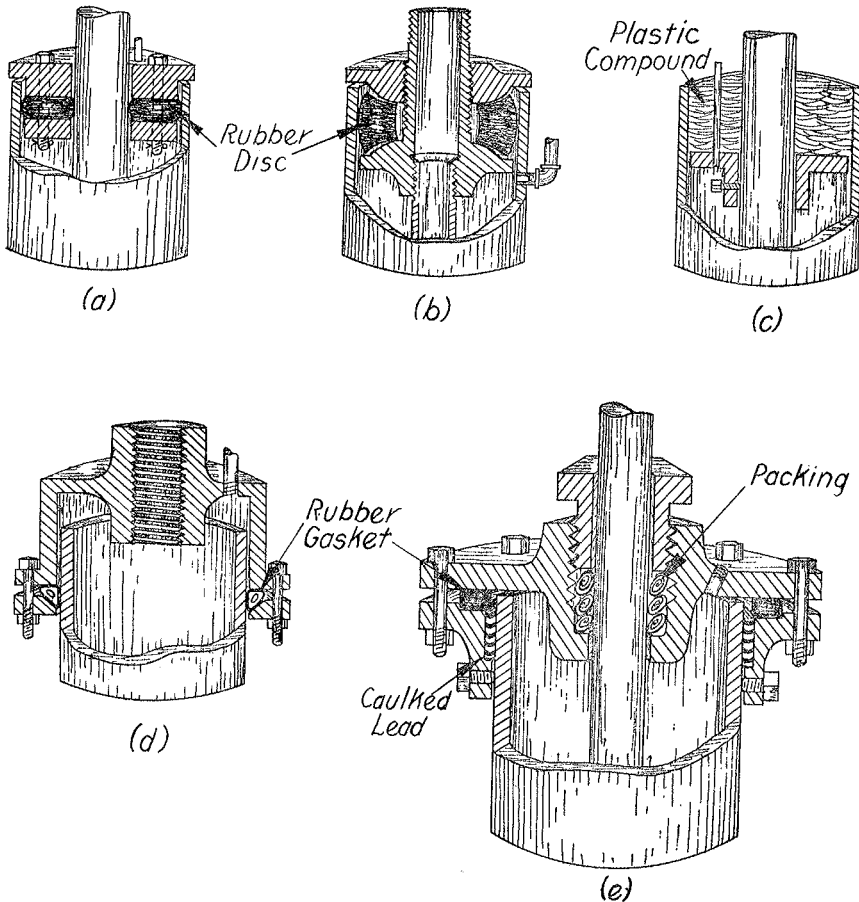

Figure 11. Types of Well Seals. (a) and (b): Seals using inside compressed rubber. (c) using inside plastic compound. (d) using outside compressed rubber gasket. (e) using caulked lead, compressed rubber and packing. See Wis. Adm. Code section RD 12.09 (3).