

Chapter Ind 35

SAFETY IN CONSTRUCTION

Ind 35.001	Scope of code	Ind 35.20	Scaffold platforms
Ind 35.01	Responsibility for provision and maintenance of safeguards	Ind 35.21	Guard railing and toeboards for scaffolds
Ind 35.02	Definitions	Ind 35.22	Roofing scaffolds
Ind 35.03	Guard railing	Ind 35.23	Protection of openings in floors and roofs
Ind 35.04	Toeboard	Ind 35.24	Construction and protection of runways
Ind 35.05	Standard lumber and timber dimensions	Ind 35.25	Ladders
Ind 35.06	Demolition work on structures	Ind 35.26	Stairs and stair wells
Ind 35.07	Excavation	Ind 35.27	Temporary floors
Ind 35.08	Shoring	Ind 35.28	Elevators for workmen
Ind 35.09	Falsework	Ind 35.29	Material hoists
Ind 35.10	Scaffolds required	Ind 35.30	Derricks
Ind 35.11	General scaffold requirements	Ind 35.31	Operation of hoists and derricks
Ind 35.12	Scaffold materials	Ind 35.32	Fibre and wire rope
Ind 35.13	Scaffold design and workmanship	Ind 35.33	Protection from falling objects
Ind 35.14	Built-up wood scaffolds and sectional metal scaffolds	Ind 35.34	Slippery conditions
Ind 35.15	Square scaffolds	Ind 35.35	Storage of materials
Ind 35.16	Horse scaffolds	Ind 35.36	Storage or disposal of debris
Ind 35.17	Carpenter's bracket scaffolds	Ind 35.37	Electrical hazards
Ind 35.18	Suspended scaffolds, swinging scaffolds, swinging chair scaffolds and boatswain chairs	Ind 35.38	Illumination
Ind 35.19	Ladder jack scaffolds	Ind 35.39	Toilets
		Ind 35.40	Drinking water
		Ind 35.41	Protection of machine operators from the weather
		Ind 35.42	Inspection and maintenance

Ind 35.001 Scope of code. (1) The requirements of sections Ind 35.001 to Ind 35.42, inclusive, shall apply to the erection (including excavation), repair, alteration, renovation, relocation and demolition of buildings and other structures, or any part thereof, and to all operations incident to the equipping and maintenance of buildings and other structures.

(2) By equipping, is meant the installation, repair or changing of equipment needed in the furnishing and distribution of water, drainage, light, heat, power, ventilation, communication, conveyance, radio, television, refrigeration and similar building service, and does not include the installation or changing of occupancy equipment, such as machinery (and all accessories) used in manufacturing processes.

Note. The installation or changing of machinery (and all accessories) used in manufacturing processes comes within the scope of the general orders on safety issued by the industrial commission.

Ind 35.01 Responsibility for provision and maintenance of safeguards. The responsibility for the provision and maintenance of the protection for a workman required under this code rests with his immediate employer, unless this responsibility is otherwise definitely assigned in the specifications or contract, and properly executed by the assignee.

WISCONSIN ADMINISTRATIVE CODE

Ind 35.02 Definitions. (1) The term "brace" shall mean a tie or strut that holds one point in a fixed position with respect to another point. Bracing is a system of braces which prevents distortion of a structure.

(2) The term "built-up scaffold" shall mean a rigid scaffold constructed of appropriate materials and parts, built where it is to be used, and which is ordinarily dismantled when its purpose at that place has been accomplished.

(3) The term "carpenter's bracket scaffold" shall mean a scaffold, the platform of which is composed of planks or boards and supported on triangular braced brackets secured to a building or structure.

(4) The term "chicken ladder" shall mean a single plank or board having cleats attached at equal intervals in a manner to permit the use of the finished device as a means of walking or crawling up or down steep inclines.

(5) The term "derrick" shall mean a combination of power, boom, flexible cable and accessories, without a car, used to elevate, lower or swing materials or equipment from one position to another.

(6) The term "design", as used in this code, shall mean to plan or devise, and does not necessarily involve the preparation of drawings.

(7) The term "elevator", as used in this code, shall mean an elevating and lowering device, other than a dumbwaiter, provided with a platform and cage which is located in a permanent or temporary shaftway and is designed or used to carry persons or materials from one level to another.

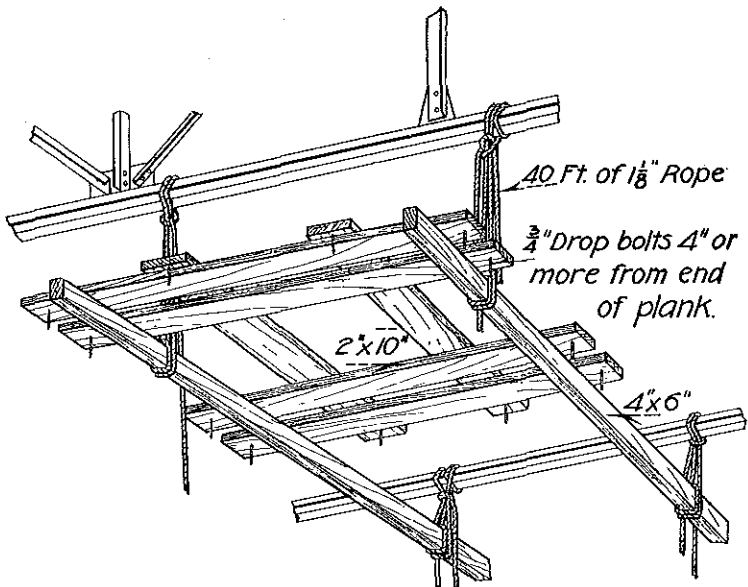

Fig. 1.—Hanging (Riveters) Scaffold

(8) The term "falsework" shall mean any construction used to support or form plastic or easily distorted parts of a structure, such as fresh concrete and incompletely assembled parts or members of a structure which cannot retain their permanent shape without such support, and which remains in place until the part or member is capable of sustaining itself and any superimposed load.

(9) The term "hanging scaffold" shall mean a scaffold consisting of a plank platform resting on two parallel horizontal beams, called needle beams, suspended from overhead construction by ropes.

(10) The term "horse" shall mean a beam having four legs fastened and braced thereto in a manner to provide a rigid, stable and portable support for working platforms.

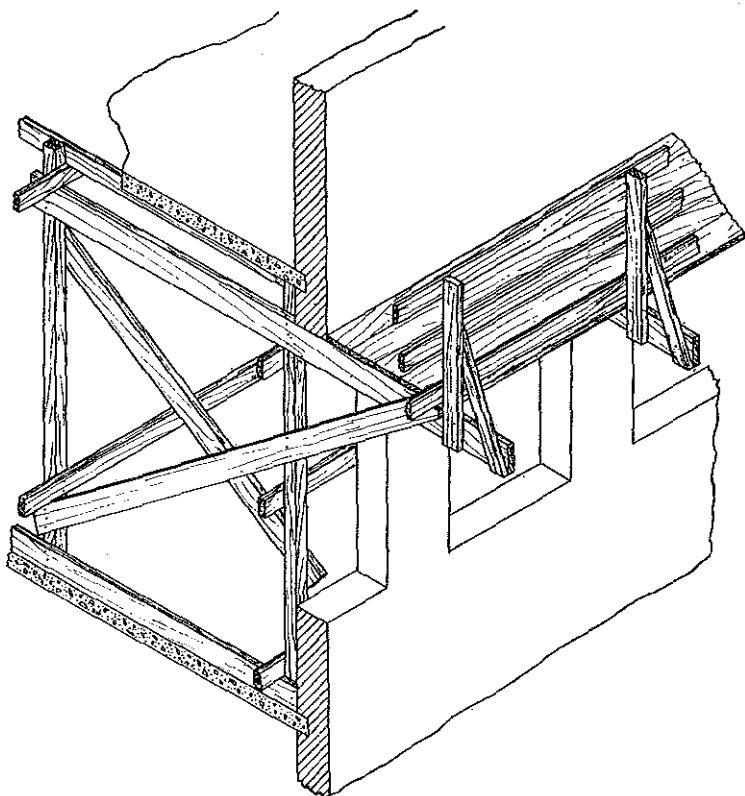

Fig. 2.—Outrigger Scaffold

(11) The term "independent post scaffold" shall mean a scaffold wherein all of the support consists of posts, not a part of the building construction, provided for that purpose.

(12) The term "ladder" shall mean a device or piece of equipment consisting of 2 or more approximately parallel side rails joined together at regular intervals with uniformly spaced cross pieces called rungs, steps, or cleats, used for ascending to or descending from elevated places.

(a) An extension ladder is a ladder consisting of 2 or more sections traveling in guides or brackets so arranged that it may be adjusted to variable lengths.

(13) The term "ladder jack scaffold" shall mean a scaffold, the platform of which is supported by jacks attached to ladders.

(14) The term "ledger" shall mean a member of a scaffold which extends horizontally from post to post at right angles to the putlogs, forms a tie between posts, supports the putlogs and is a part of the scaffold bracing.

(15) The term "material hoist" shall mean a device having a platform, cage or other container in which only materials are elevated or lowered from one level to another.

(16) The term "outrigger scaffold" shall mean a working platform supported by beams or outriggers projecting from a building, the inner ends of which are secured inside the building.

(17) The term "putlog" shall mean a scaffold member upon which the floor or platform is laid; in the case of an independent post scaffold each end of the putlog rests on a ledger; in the case of a single post scaffold, one end of the putlog rests on a ledger and the other end on the building construction.

(18) The term "runway" shall mean any aisle, walk or drive constructed or maintained as a passageway for workmen or rolling equipment.

(19) The term "scaffold" shall mean a temporarily located elevated platform used for supporting workmen and materials in the course of constructing, wrecking, altering, repairing, cleaning, or pointing and to all operations incident to the equipping and maintenance of buildings or other structures.

(20) The term "shoring" shall mean any temporary construction or device which is used to support a structure, or any part thereof, in place until the permanent support therefor is provided.

(21) The term "single post scaffold" shall mean a scaffold wherein the putlogs are supported at one end by a ledger and at the other by the building or structure.

(22) The term "square" shall mean a framed structure built up of vertical and horizontal members and braces, which when used in pairs and set up and braced longitudinally, provides a support for a working platform.

(23) The term "stepladder" shall mean a portable ladder having flat steps and so constructed with a back frame, either hinged or rigid, as to be self-supporting.

(24) The term "structure" shall mean anything that is built or constructed, an edifice or building of any kind, or any piece of work artificially built up or composed of parts joined together in some definite manner.

(25) The term "suspended scaffold" shall mean a scaffold suspended from more than two points on a building or structure by means of steel cables, and is raised and lowered for position by hoisting mechanism.

(26) The term "swinging scaffold" shall mean a scaffold suspended by means of ropes or cables from not more than 2 points on a building or structure in a manner to permit of raising and lowering for position adjustment.

(27) The terms "swinging chair scaffold" and "boatswain chair" shall mean a scaffold suspended by means of a rope or cable from one point on a building or structure in a manner to permit raising or lowering for position adjustment.

(28) The term "unsupported height", as applied to scaffold framework, shall mean the distance between points where braces, ties or ledgers are attached, or other lateral support is provided.

Ind 35.03 Guard railing. A guard railing shall have a vertical height of 42 inches from the floor or platform to the upper surface of the top rail. An intermediate rail shall be provided midway between the floor or platform and the under side of the top rail. The construction shall be as follows:

(1) **WOOD GUARD RAILING.** The posts or uprights shall not be less than nominal 2x4 inches spaced not to exceed 8 feet center to center, the top rail not less than nominal 2x4 inches and the intermediate rail not less than nominal 1x6 inches. The posts shall be fastened and braced in place and the whole assembly shall be capable of withstanding a load of 175 pounds applied at any direction at any point of the top rail.

(2) **PIPE GUARD RAILING.** The posts or uprights shall be constructed of $1\frac{1}{4}$ inch pipe inside diameter or $1\frac{1}{4}$ inch tubing outside diameter. The top rails shall be of not less than $1\frac{1}{4}$ inch pipe and the intermediate rails of not less than 1 inch pipe, both inside diameter, or of tubing not less than 1 inch outside diameter. The spacing of posts or uprights shall not exceed 8 feet and shall be anchored as in (1).

(3) **STRUCTURAL METAL GUARD RAILING.** The posts or uprights and top rail shall be of angle iron not less than $1\frac{1}{2} \times 1\frac{1}{2} \times \frac{3}{8}$ inches or the equivalent strength in other shapes, and the intermediate rail shall be of angle iron not less than $1\frac{1}{4} \times 1\frac{1}{4} \times \frac{1}{8}$ inches or the equivalent strength in other shapes. The spacing of posts or uprights shall not exceed 8 feet and shall be anchored as in (1).

Ind 35.04 Toeboard. A toeboard shall consist of a wood board not less than nominal 1x6 inches resting edgewise on the working floor or platform, fastened and braced in place. Metal or plywood toeboards of equal height and strength may also be used.

Ind 35.05 Standard lumber and timber dimensions. (Wherever the sectional dimensions of lumber and timber are referred to as nominal in this code, the actual sectional dimensions shall be not less than

those shown in the second column for corresponding nominal dimensions in the following table:

Nominal Dimensions, In Inches	Actual Dimensions, In Inches
1 x 3	25/32 x 25/8
1 x 4	25/32 x 35/8
1 x 6	25/32 x 55/8
1 x 8	25/32 x 71/2
1 x 10	25/32 x 91/2
1 x 12	25/32 x 111/2
2 x 4	15/8 x 35/8
2 x 6	15/8 x 55/8
2 x 8	15/8 x 71/2
2 x 10	15/8 x 91/2
2 x 12	15/8 x 111/2
3 x 4	25/8 x 35/8
3 x 6	25/8 x 55/8
3 x 8	25/8 x 71/2
3 x 10	25/8 x 91/2
3 x 12	25/8 x 111/2
4 x 4	35/8 x 35/8
4 x 6	35/8 x 55/8
4 x 8	35/8 x 71/2
4 x 10	35/8 x 91/2
4 x 12	35/8 x 111/2
6 x 6	51/2 x 51/2
6 x 8	51/2 x 71/2
6 x 10	51/2 x 91/2
6 x 12	51/2 x 111/2
8 x 8	71/2 x 71/2
8 x 10	71/2 x 91/2
8 x 12	71/2 x 111/2

Ind 35.06 Demolition work on structures. (1) All materials or parts removed from the elevated portions of any structure in alteration, repair, or demolition work thereon shall be lowered to grade or other storage or disposal level by means of appropriate hoisting equipment, except such material may be dropped through holes in the floor if such holes and the ground or floor on which the material is dropped are provided with proper guard rails at least 20 feet from the perimeter of the opening or chutes may be used. All such chutes shall be enclosed on all 4 sides if they are at an angle of more than 45 degrees with the horizontal. If less than 45 degrees with the horizontal, the upper side may be left open.

(2) All floor openings in demolition work, other than those openings which are in use, shall be completely covered as described in section Ind 35.23.

(3) No object or volume of material shall be caused to tip, or fall, onto a floor or other part of a structure which may be caused to fail because of such practice, except that the whole or part of a structure may be pulled down if no persons are exposed to the hazard of falling or flying materials.

(4) Where workmen or frequenters may be exposed to material or objects which may accidentally fall from upper working levels, the exposed area shall be shut off from access by means of standard guard railings, or better. If the structure to be demolished is more than 2 stories or 25 feet high above the sidewalk and the horizontal distance from the inside of the sidewalk to the structure is 15 feet or less, a substantial sidewalk shed shall be constructed over the entire width of the sidewalk adjacent to the structure. The sidewalk shed shall be capable of sustaining a live load of 150 pounds per square foot, or more, and shall be lighted by natural or artificial means to produce an intensity of illumination of not less than 2 foot-candles.

Ind 35.07 Excavation. (1) All work in excavation more than 8 feet in minimum horizontal dimension and which is 4 feet or more in depth, where there is danger of slides or cave-ins, shall be supported by substantial sheet-piling and bracing, or other effective means, or the sides of the excavation sloped to the angle of repose of the material being excavated.

(2) Excavations, in other than hard rock, below the level of the top of the footing or base of any foundation or retaining wall shall not be permitted unless the wall is properly shored, braced, or underpinned to insure the stability of the wall.

(3) A guard railing as described in section Ind 35.03, or other effective guard or barricade, shall be provided at or near the edge of an excavation as soon as possible, except where the installation of such safeguard will interfere with the excavation or other work.

(4) All excavation to which employes or frequenters may be exposed at night shall have red lanterns or torches placed at unbarri-caded points, and along the exposed side where the excavation adjoins a public thoroughfare.

Note. The protection of workmen in excavation less than 8 feet in minimum horizontal dimension shall be as required under the general orders on tunnel, caisson and trench construction issued by the industrial commission. Where explosives are used, the requirements of the general orders on explosives, issued by the industrial commission shall be complied with.

Ind 35.08 Shoring. (1) All shoring, as defined in section Ind 35.02, done on projects within the scope of this code shall be done in a manner which will not overstress any part of the structure being shored or any part of the shoring construction or device. By over-stress is meant exceeding the stresses permitted for various materials under section Ind 35.13.

(2) The shoring construction or device shall in every case be stable in itself and shall not disturb the stability of the structure, or part thereof, being shored.

Ind 35.09 Falsework. All falsework, as defined in section Ind 35.02, which supports workmen, material or equipment at any time shall comply with the requirements that apply to scaffolds in this code, except that the requirements for guard rails and toeboards need not apply.

Ind 35.10 Scaffolds required. Scaffolds which comply with the requirements of this code shall be provided to furnish reasonably safe working places for workmen in exposed or elevated places except that ladders may be used where work can be safely done for short periods.

Ind 35.11 General scaffold requirements. (1) All scaffolds, and parts thereof, shall be erected, installed, maintained and inspected in accordance with the provisions of this code, and such work shall be done, and the scaffold removed, only by persons experienced in such work. Dismantling and removal of scaffolds shall always proceed systematically, and the platform planks shall first be removed, proceeding from top to bottom, before any braces, ledgers or putlogs are removed or loosened. When braces are removed, this removal shall also proceed from top to bottom but no braces or other supports shall be disturbed while any person is on the scaffold.

(2) All post, square and outrigger scaffolds shall be braced to prevent the lateral movement or distortion of the whole or any part thereof.

(3) No scaffold post shall stand directly on the ground but shall be provided with a footing or foundation of sufficient size and strength to spread the load from the post over a sufficient area to prevent settlement. If the footing is of wood, it shall be a solid block or plank not less than 2 inches nominal thickness and not less than one foot square and shall be securely nailed to the post and shall be placed on solid soil sufficiently below the surface to prevent displacement. The use of objects, such as building tile or blocks, loose brick, boxes, barrels, loose board construction, and similar material for the support of posts or scaffolds is prohibited.

(4) No scaffold or part thereof shall at any time be loaded or used in a manner such that the loads and stresses permitted under section Ind 35.13 will be exceeded.

(5) Every scaffold member, except floor planks or boards, subjected to bending stress shall be set in the position to resist greatest bending load.

3,
5th, 7th
Ind 35.12 Scaffold materials. (1) All lumber used in scaffolds, except lumber used for braces only, shall be of stress grade material and shall be of sufficient size, quality, and strength to carry the imposed loads safely without exceeding the allowable working stresses specified in section Ind ~~53.28~~ of the Wisconsin state building code. Lumber used for braces shall be sound, free from cross grain, shakes, or other defects that will impair its strength or durability.

(2) All metal used in any part of a scaffold shall conform to the standard specifications of the American Society for Testing Materials, as follows:

(a) For Steel, Standard Specifications for Structural Steel for Bridges and Buildings, Serial Designation A7-50 T

(b) For Wrought Iron, Standard Specifications for Refined Wrought Iron Plates, Serial Designation A42-47

(c) For Cast Iron, Standard Specifications for Gray Iron Castings, Serial Designation A48-48

Ind 35.13 Scaffold design and workmanship. (1) All scaffolds shall be so designed and built that the unit stresses in the material of any member when under maximum loading will not exceed those specified for that material in chapter 53 of the Wisconsin state building code issued by the industrial commission.

(2) The following tables show the allowable safe load for some of the beams and posts commonly used in scaffold construction. These

(f) Putlogs for the support of working platforms shall be square or rectangular in cross section, set with their greatest dimensions vertical and long enough to project over the ledgers not less than 6 inches nor more than 12 inches.

(g) Putlogs shall be supported on the ledgers, located against the sides of the posts and nailed to both the post and the ledger. Where intermediate putlogs are used, they shall be secured to the ledger by nailing, cleats or clamps so that they cannot slip from the supporting member.

(h) For single post scaffolds, the inner end of the putlog shall rest in the wall of the building at least 4 inches and shall not be notched or otherwise reduced in section to fit bearing holes in walls. Where, instead of putlogs, cross-beams fastened to posts (or to a part of the building construction) are used to support scaffold platforms, such beams shall be not less than nominal 2x6 inches in cross sectional dimension. No putlog or similar cross beam having a cross sectional dimension less than 4 inches (nominal) shall be used to support a platform on which wheeling is to be done, unless 2 putlogs, one nailed to each of 2 opposite sides of each post, are provided.

(2) SECTIONAL METAL SCAFFOLDS AND ROLLING METAL SCAFFOLDS.

(a) The following additional requirements shall apply to sectional metal scaffolds and rolling metal scaffolds.

(b) The frame of a sectional metal scaffold shall incorporate the posts and horizontal beams substantially braced for supporting the planks for the scaffold platform. The width of the frame shall not exceed 6 feet.

(c) All cross brace members for tying the frame together shall be designed to automatically square and align the frame, so the erected scaffold is always plumb, square and rigid.

(d) Coupling pins shall be provided for connecting the posts of the frame to hold the frames in a fixed position.

(e) Base plates which telescope into the foot of the posts shall be provided for securing the frames to the footing or foundation.

(f) All accessories, such as leveling jacks, brackets, putlogs, frame extensions, straddle trestles, etc., shall have the same load carrying capacity as the scaffold with which they are used.

(3) LIGHT DUTY SCAFFOLDS. All light duty metal scaffolds shall be designed to safely support a live load of at least 25 pounds per square foot with the load concentrated on one level or divided between various levels. The height shall not exceed 40 feet and the distance between frames shall not exceed 10 feet along the length of the scaffold.

(4) SINGLE POLE SCAFFOLDS. All single pole metal scaffolds shall be designed to safely support a live load of at least 25 pounds per square foot, with the load concentrated on one level or divided between various levels. The height shall not exceed 15 feet and the distance between poles shall not exceed 10 feet along the length of the scaffold.

(5) LIGHT DUTY SCAFFOLDS. Light duty scaffolds may be used for the accommodation of carpenters, painters, and other similar trades where the scaffold supports no load other than the workmen, tools, and a minimum amount of light weight material.

(6) **HEAVY DUTY SCAFFOLDS.** (a) All heavy duty metal scaffolds shall be designed to safely support a live load of at least 75 pounds per square foot with the load concentrated on one level or divided between various levels. The height shall not exceed 125 feet and the distance between frames shall not exceed 8 feet.

(b) Heavy duty scaffolds shall be used for the accommodation of masons and similar trades where the scaffolds support building material in addition to workmen, tools, or vehicles.

(c) A factor of safety of not less than 4 shall be used in the design of all metal scaffolds and this or a greater factor of safety shall be observed in the use of all such scaffolds.

(d) The scaffold shall be securely anchored to the building at distances of not more than 30 feet horizontally and 25 feet vertically.

(7) **SCALING SCAFFOLD.** Ladders complying with section Ind 35.25 shall be provided for scaling the scaffold.

(8) **DESIGN OF METAL SCAFFOLDS.** All unit parts of metal scaffolds shall be so designed that they may be readily inspected and any omission of parts or defects in erection can be readily detected.

(9) **PAINTING OF METAL SCAFFOLDS.** All metal scaffold members, except those constructed of aluminum, shall be painted with a weather resisting and rust preventing material.

(10) **PLATFORMS.** Scaffold platforms constructed of plank shall comply with the requirements of section Ind 35.20. Guard railings and toeboards shall comply with sections Ind 35.03 and Ind 35.04.

(11) **APPROVAL.** Complete plans and specifications, together with structural calculations to prove compliance with this section for each type and design of metal scaffolds, shall be submitted to the industrial commission for approval before the equipment is used. The industrial commission will ordinarily accept a certified test report made by a recognized testing laboratory in lieu of plans and design data.

(12) **ROLLING SCAFFOLDS.** (a) Rolling tower scaffolds shall have a base dimension of not less than 20 per cent of the height and the maximum unsupported height shall not exceed 40 feet. Any rolling tower over 40 feet in height shall be guyed or supported by some other approved method.

(b) All rolling towers shall be designed to support a live load of at least 25 pounds per square foot.

(c) A factor of safety of 4 shall be used in the design of all rolling tower scaffolds and this or a greater factor of safety shall be observed in the use of all such scaffolds.

(d) Rollers or wheels of sufficient diameter and having the same load carrying capacity as the tower shall be used. The rolling mechanism shall be equipped with a safety brake actuating on both the swivel and the wheels or otherwise blocked to hold the tower in position. No rolling tower scaffold shall be moved while supporting workmen.

(e) All tower members shall be painted as specified for sectional metal scaffolds.

Ind 35.15 Square scaffolds. (1) Wood squares used for the support of working platforms shall be made of material not less than nominal 2 x 4 inches in cross sectional dimension, corners abutting one another with the top and bottom members overlapping the uprights. In addition to nailing the corners, they shall be braced on both sides with nominal 1 x 6 inch bracing pieces.

(2) The squares shall have braces of nominal 1 x 8 inches in size on both sides, extending diagonally from the center of each member to the center of each adjacent member. Where the height (or width) of a square is more than 5 feet, the depth of members and braces shall be increased in direct proportion to the increase in height (or width).

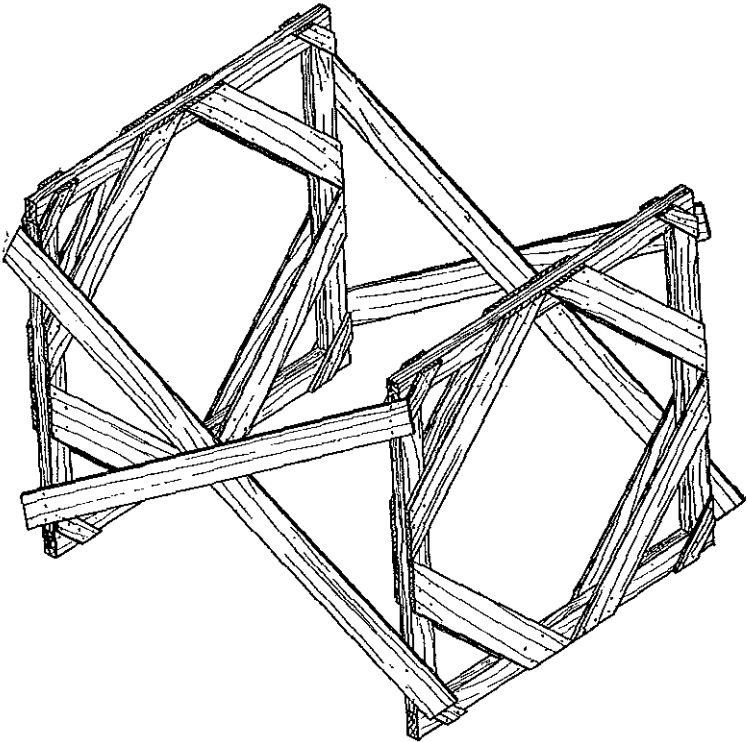

Fig. 5.—Scaffold Squares

(3) When the squares are set up, they shall be braced laterally by nominal 1 x 6 bracing on both the front and rear sides of the scaffold, the bracing to extend from the bottom of one square to the top of the next adjacent square.

(4) Squares shall not be used in scaffolds more than 3 squares, or 16 feet, in height.

Ind 35.16 Horse scaffolds. (1) Wood horses used for the support of working platforms shall be made of material not less than nominal 2 inches in thickness. The beam and legs shall conform to the requirements which apply to crossbeams and posts, sections Ind 35.12 and Ind 35.13. The legs shall be braced to the beam. Factory made horses shall be the equivalent of the above in strength, stability and rigidity and shall be of a type approved by the industrial commission.

(2) The height of a horse shall not exceed two times the minimum spread of the legs at the bottom. Horses shall not be used in scaffolds more than 2 horses, or 20 feet, in height.

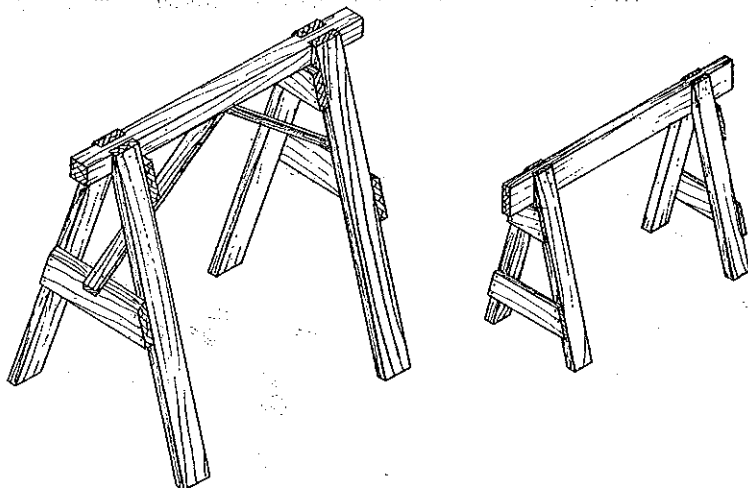

Fig. 6.—Scaffold Horses

(3) The beam and legs of every horse shall be continuous, not spliced, except that the legs may be made adjustable in an approved manner.

(4) Every horse used as a scaffold, or used to support a scaffold platform, shall rest on a solid and level floor or similar footing. No such horse shall rest directly on the ground.

Ind 35.17 Carpenter's bracket scaffolds. (1) All bracket scaffolds shall be constructed of triangular frame portable brackets, and platforms of planks. The brackets shall be spaced not more than 8 feet center to center, measured along the platform, and shall be secured to prevent turning, slipping and spreading. Nails shall not be used to secure a bracket to a building or structure except at the bottom to prevent turning or spreading.

(2) When constructed of wood, the brackets shall be of essentially clear, dressed material. Each member shall be of not less than nominal 2 inches by 3 inches, and mortised together and bolted. Each member of the bracket shall be set in a position to resist the greatest bending load. Cross grain in the bracket members shall not exceed a slope of one in 12.

TOTAL SAFE LOAD FOR BEAMS—LOAD CONCENTRATED AT CENTER OF BEAM

Allowable Unit Stress—1200 Lb. Per Square Inch

Span, in Feet	Nominal Size of Beams, in Inches, Greatest Dimension Vertical												
	2x4	2x6	2x8	2x10	2x12	3x4	3x6	3x8	4x4	4x6	6x6	6x8	8x8
4	356	357	1523	2444	3582	575	1384	2460	794	1912	2773	5156	7081
6	237	571	1015	1630	2388	383	923	1640	529	1275	1849	3437	4688
8	178	429	762	1222	1791	288	692	1230	397	956	1387	2578	3515
10	142	342	609	978	1432	230	554	984	318	765	1110	2062	2812
12	119	286	508	815	1194	192	461	321	264	688	925	1719	2344
14	101	245	435	698	1027	164	395	707	228	545	793	1477	2008
16	89	214	380	611	895	144	346	615	199	478	693	1289	1758

Where the load is distributed over the length of the beam, the safe loads in the above table may be doubled.

53, 2nd

WISCONSIN ADMINISTRATIVE CODE

tables are based on an allowed unit stress of 1200 pounds per square inch. For other kinds of timber with higher or lower allowable unit stresses, see section Ind 53.28 of the Wisconsin state building code. The safe load is in direct proportion to the allowed unit stress.

(3) No wheeling shall be done on scaffold platforms supported by posts which are less than nominal 4 x 4 inches, or equivalent in strength.

(4) Scaffolds shall not be built higher than as follows:

(a) Where the posts are of nominal 2 inch material, 24 feet;

(b) Where the posts are of nominal 3 inch material, 40 feet;

(c) Where the posts are of nominal 4 inch material, or better, no height limit.

(5) No nail smaller than the following sizes shall be used for the various thicknesses of materials in the construction of any scaffolding:

(a) 1 inch (nominal) material, 8d common (2½ inches), or 10d double head (3 inches).

(b) 2 inch (nominal) material, 16d common (3½ inches), or 20d double head (4 inches).

(c) 3 inch (nominal) material, 30d common (4½ inches), or 40d double head (5 inches).

(d) 4 inch (nominal) material, 50d common (5½ inches), or 60d double head (6 inches).

MAXIMUM PERMISSIBLE SPAN (IN FEET) FOR PUTLOGS

Allowable Unit Stress—1200 Lb. Per Sq. In.

Carpenter, Painter, Decorator and Similar Light Duty Scaffolds		Mason, Plasterer and Similar Heavy Duty Scaffolds	
Nominal Cross-Sectional Dimensions of Putlog in Inches	Span	Nominal Cross-Sectional Dimensions of Putlog in Inches	Span
2 x 6	4	2 x 8	4
2 x 8	5	2 x 10	5
2 x 10	7	2 x 12	6
2 x 12	8	4 x 4	4
4 x 4	4	4 x 6	5
4 x 6	6	6 x 6	6
		6 x 8	8

TOTAL SAFE LOADS FOR DOUGLAS FIR POSTS

Compression Parallel to Grain—1100 Lb. Per Sq. In.

Clear Height Between Braces or Ties in Feet	Nominal Cross-Sectional Dimensions of Posts in Inches							
	2x4	2x6	2x8	3x4	4x4	4x6	6x6	8x8
4	2,782	4,317	5,757	9,236	13,991	21,711	33,300	61,800
6	1,233	1,944	2,553	5,212	12,055	18,706	32,243	61,800
8	693	1,070	1,430	2,980	7,720	11,900	29,981	60,142
10	-----	-----	-----	1,873	4,929	7,649	25,322	57,606
12	-----	-----	-----	1,300	3,426	5,317	18,112	52,965
14	-----	-----	-----	-----	2,512	3,909	13,365	45,416
16	-----	-----	-----	-----	1,930	2,980	10,207	35,276
18	-----	-----	-----	-----	-----	-----	8,050	27,873
20	-----	-----	-----	-----	-----	-----	6,540	22,577

(6) No nail shall be subjected to straight pull in any portion of a scaffold except nails which fasten sheathing boards to the framework that supports carpenter's bracket scaffolds as specified in section Ind 35.17.

(7) All nails shall be driven full length, except in the case of double-headed nails, the nails shall be driven tightly to the guard head. A sufficient number of nails shall be driven at each connection to develop the designed strength of the scaffold.

(a) For load supporting members, such as ledgers, a minimum of 5 nails shall be driven at each connection.

(b) For braces and guard rails, a minimum of 2 nails shall be driven at each connection.

History: 1-2-56; am. (1), Register, October, 1963, No. 94, eff. 11-1-63.

Ind 35.14 Built-up wood scaffolds and sectional metal scaffolds.

(1) **WOOD SCAFFOLDS.** (a) Posts for wood post scaffolds shall be spaced not more than 8 feet center to center, measured along the platform, and shall conform to the requirements of section Ind 35.13.

(b) Where necessary to increase the height of a wood post by splicing, the squared end of the upper section shall rest evenly upon the squared end of the lower section, and the 2 ends shall be held in place by fastening not less than 2 wood cleats, each not less than 4 feet in length, centered approximately at the joint, to adjoining sides of such post. The combined sectional area of the cleats shall be not less than that of the post. Every post having joints shall be braced at a point not more than 3 feet from the joint.

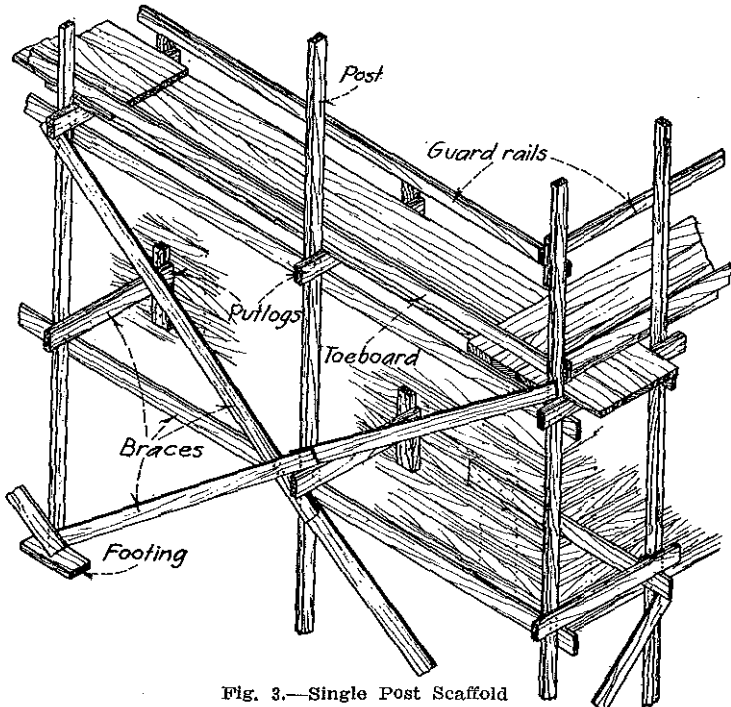

Fig. 3.—Single Post Scaffold

(c) In the construction of single post scaffolds, the scaffold framework shall be braced to the adjoining permanent structure. In the case of independent post scaffolds, the scaffold framework shall be braced independent of the adjoining permanent structure.

(d) Ledgers shall be not less than nominal 2 x 8 inches in sectional dimension, except that where putlogs are supported only at posts, the section of the ledger may be reduced to not less than nominal 2 x 6 inches in sectional dimension. Ledgers shall not be loosened or removed until the scaffold is dismantled.

(e) Ledgers shall be fastened to the inside (platform side) of posts, except where they interfere with bracing. In the case of scaffolds used by masons and upon which wheeling is done, where such fastening is by nailing to a post, the nail support shall be reinforced by a cleat of the same thickness as the ledger, nailed to the post directly under the ledger.

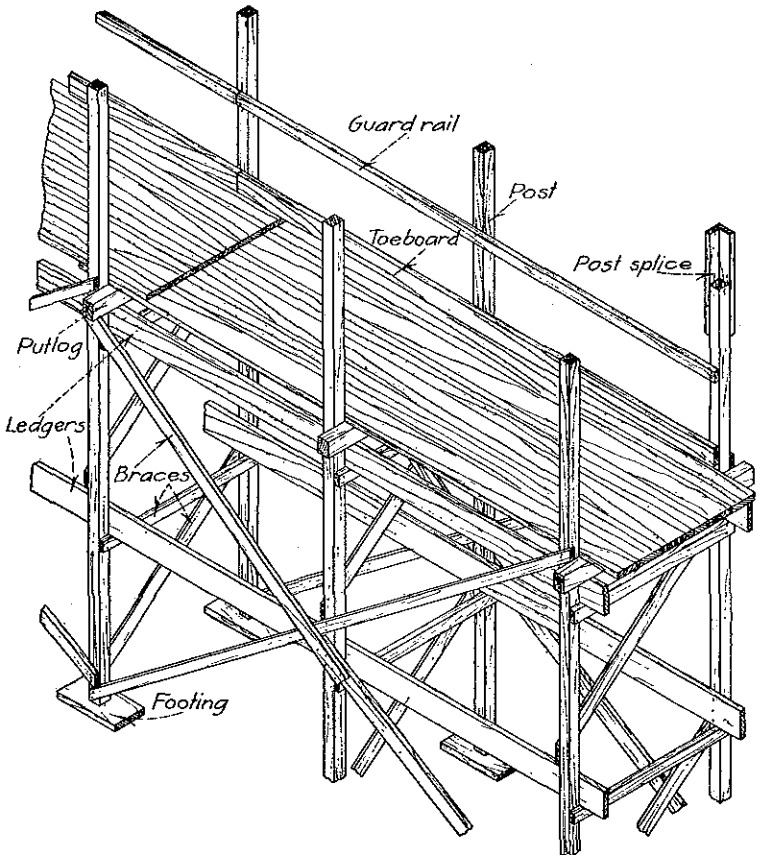

Fig. 4.—Independent Post (Masonry and Wheeling) Scaffold

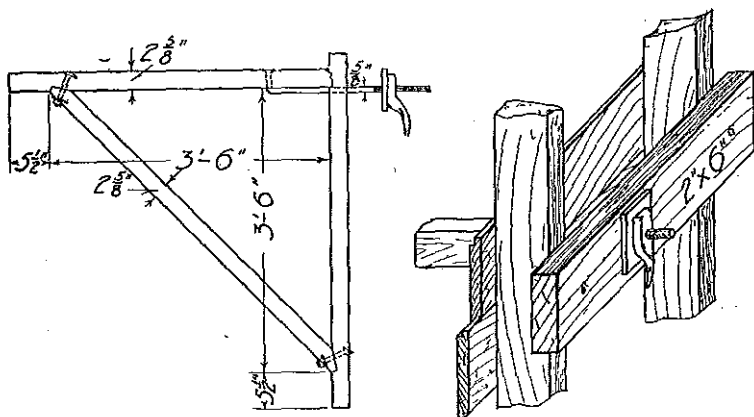

Fig. 7.—Carpenter's Bracket or Jack

(a) Wood brackets shall be anchored to the building structure by means of a bolt not less than $\frac{5}{8}$ -inch in diameter welded to a flat iron member, not less than 2 feet long, drilled, spiked and set in flush with the top surface of the horizontal member. The bolt shall be of sufficient length to extend well within the studs (when secured to a frame building) and provided with a washer and lever handle nut. A nominal 2x6-inch block shall be placed horizontally across the inside of 2 studs with the bolt passing through the block and the nut turned up tight.

(3) When constructed of steel, each member shall be of not less than 2 x 2 x $\frac{3}{8}$ -inch angles or their equivalent. Steel brackets shall be anchored to the framework of the building by means of a bolt not less than $\frac{5}{8}$ -inch in diameter, welded or riveted to the top horizontal member of the bracket or the equivalent. The bolt shall be of suffi-

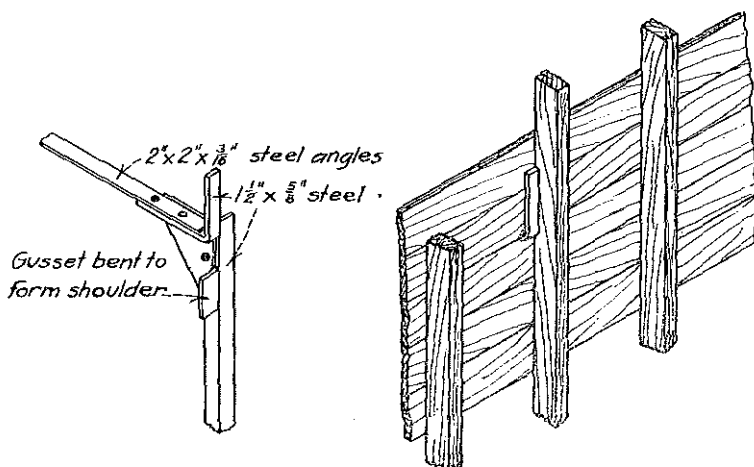

Fig. 8.—Hook Detail for Carpenter Scaffold Bracket

cient length to extend through the wall and shall be provided with a washer and lever handle nut anchored to the building framework as specified for wood brackets, except that steel brackets may be supported by the sheathing under the following conditions:

(a) A bracket hook of not less than $1\frac{1}{2}$ x $\frac{5}{8}$ -inch steel shall be designed to enter the sheathing at the lower edge of a board adjacent to a member of the framework and shall distribute the pull and pressure due to the bracket load over the full width of that board, and shall apply the weight of the bracket load to the board below the hook entrance opening. (See Fig. 8.)

(b) The nails which fasten the upper sheathing board to the framework shall be plainly visible at all times while the scaffold is in use.

(c) No joint in the sheathing boards that support a bracket scaffold shall be less than 2 feet from the bracket hook opening.

(4) Where the building walls are constructed with composition sheathing, nominal 2 x 6-inch blocks shall be nailed horizontally across the outside of 2 studs at the top and bottom of the bracket, to prevent the bracket from breaking through the sheathing.

History: Cr. Register, June, 1956, No. 6, eff. 8-1-56.

Ind 35.18 Suspended scaffolds, swinging scaffolds, swinging chair scaffolds and boatswain chairs. (1) All mechanism and parts of the suspension system of any suspended scaffold shall be of a type and design approved by the industrial commission.

Note. To secure such approval, plans and specifications for the complete suspension system, including details of operating mechanism, shall be submitted to the industrial commission.

(2) Suspended scaffolds shall be supported by steel wire rope suspended from overhead thrustouts or outriggers, consisting of steel I-beams or channels securely anchored to the framework of the building by U-bolts and anchor plates, tightened and made secure by washers and nuts. If channel irons are used, they shall be in pairs, placed parallel and fastened together by pipe separators and bolts, with the channel flanges turned out. All beams shall be set with their webs vertical and shall be equivalent in strength to 7 inch 15.3 pound I-beams and at least 15 feet long.

(3) Such beams resting on the structurally completed roof of a building may be held in place by weighting if the weighting is done on a stable platform resting on the beams, and the weighting force is equal to not less than 3 times the overturning force due to the maximum suspended load.

(4) Wire rope which conforms to the requirements of section Ind 35.32 shall be used to support all suspended scaffolds.

(5) Swinging scaffolds shall be supported in the manner required for suspended scaffolds, or may be supported by the completed wall of a structure by means of forged iron or steel hooks, or other equivalent devices, with bearing so arranged as to distribute the load at each anchorage uniformly along a horizontal section of the wall. The hooks shall be tied back to an anchorage on the building.

(6) The stirrups or hangers supporting each end of the platform shall be made of wrought iron having a cross sectional area equal to $\frac{3}{8}$ x $1\frac{1}{4}$ inch, or if round, not less than $\frac{3}{4}$ inch in diameter or of other material having the equivalent strength. The hangers shall be so designed as to support the guard rail, intermediate rail, and toe-

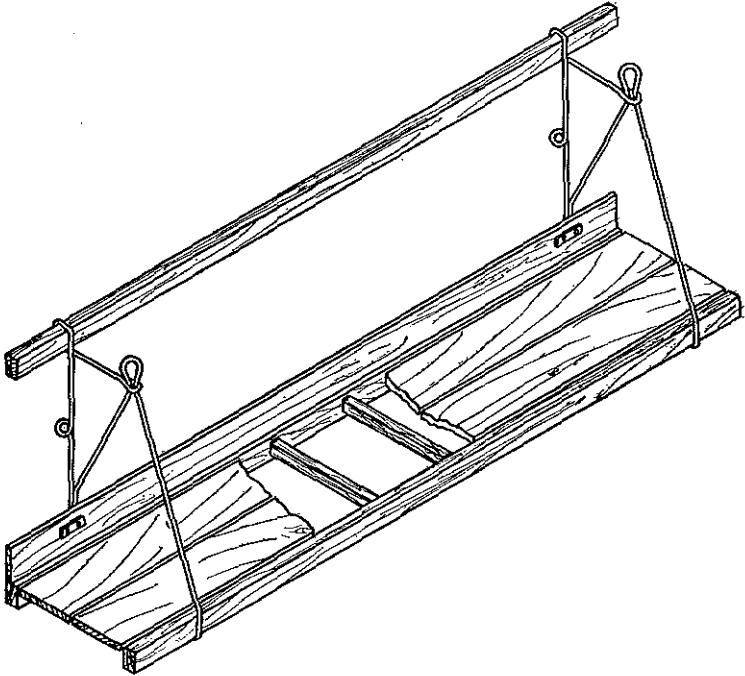

Fig. 9.—Swinging Scaffold

board, as required by this code. A center support attached to the guard rail and toeboard shall be provided for all swinging scaffolds more than 12 feet in length.

(7) Where more than one swinging scaffold is used on any job, there shall be no connection between such scaffolds unless the individual scaffolds are so arranged that they cannot be moved while the connecting platforms are in place.

(8) A life line, with fixed end fastened independent of the scaffold and with free end extending to the ground, shall be provided for each workman on a swinging scaffold. Each workman on a swinging scaffold shall be secured with a life line, such as by passing the life line through a loop or ring in a safety belt worn by him. It is also recommended that life lines be provided in connection with suspended scaffolds wherever possible.

(9) Wire rope or Manila rope which conforms to the requirements of section Ind 35.32 shall be used to support all swinging scaffolds, swinging chair scaffolds and boatswain chairs.

(10) Swinging chair scaffolds shall have a rigid metal frame constructed of not less than $\frac{1}{2}$ " x $1\frac{1}{2}$ " bars extending around the under side of a nominal 2" x 10" plank seat. The frame shall be at least 42 inches in height and not less than 24 inches in width. The chair shall have a back support constructed of a $\frac{1}{2}$ " x $1\frac{1}{2}$ " bar or equal located at least 16 inches above the seat and having a brace extending from

the center point of the back support to the center of the frame below the seat. A metal eye or loop having a cross sectional area equal to that of the frame shall be provided at the top of the frame for fastening the rope or cable. The seat shall be bolted to the bottom of the frame and all metal connections shall be welded, bolted or riveted.

(11) Every workman using a swinging chair scaffold shall be provided with a safety belt secured to an independent life line.

(12) A boatswain chair shall have a seat not less than 2 feet long constructed of a nominal 2" x 12" plank and having the ends bound with a metal strap to prevent splitting. The chair shall be supported by means of a sling attached to all 4 corners of the seat. The sling ropes shall be fastened to a metal ring or loop not more than 2 feet above the seat and having a guard rope at back approximately 16 inches above the seat.

(13) Every workman using a boatswain chair shall be provided with a safety belt secured to an independent life line.

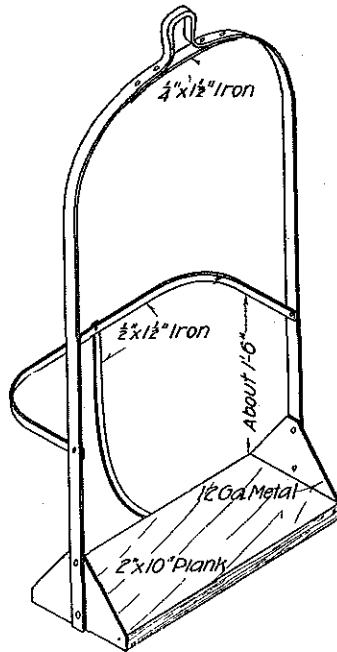

Fig. 10.—Swinging (Chair) Scaffold

Ind 35.19 Ladder jack scaffolds. (1) All ladder jacks shall be of a type approved by the industrial commission and shall be so designed that they will bear on the side rails when used on wood ladders and shall be clamped or otherwise securely fastened to the ladder. Ladder jacks not bearing on the side rails may be used on the rungs of metal ladders or on the rungs of wood ladders which are reinforced with a metal bar or rod extending through the side rails.

(2) Every ladder jack scaffold shall be composed of 2 ladders, 2 ladder jacks and a platform plank not less than nominal 2" x 10".

Where lap planks are used, the planks shall be supported at each lap by a ladder jack attached to a separate ladder.

(3) Ladder jack scaffolds shall not be used at a greater height than 35 feet above the ground or working level.

(4) The use of each ladder jack scaffold is restricted to not more than 2 persons and not more than 70 pounds of material or equipment shall be permitted on the scaffold at any one time.

(5) All ladders used in conjunction with ladder jacks shall conform to the requirements set forth under paragraphs (1) to (4), inclusive, of section Ind 35.25.

Note—See Ind 35.20 for additional scaffolding requirements.

History: 1-2-56; am. Register, September, 1958, No. 33, eff. 10-1-58.

Ind 35.20 Scaffold platforms. (1) Planks for scaffold platforms shall be not less than nominal 2" x 10". The span of scaffold planks shall not be greater than 8 feet between supports, except that for painting, decorating and paper hanging work the span of nominal 2" x 10" planks (or wider) may exceed 8 feet, but not more than 12 feet, if selected planks, which have been tested with a load at least 2 times as great as the greatest loads which the planks are to carry are used. Where tested planks are used, the top surface of the plank shall be marked and the plank shall be used with that side up.

(2) Where wheeling is to be done on scaffold platforms, the span of planks shall not exceed 6 feet for wheelbarrows and 5 feet for carts. Planks used in a scaffold platform shall be of uniform thickness.

(3) The safe load for planks under this section is indicated in the following table. The table applies to coast type Douglas fir, based on an allowable stress of 1200 pounds per square inch. The safe load for other grades and other woods is in direct proportion to the allowable stress. The safe load for planks of other widths is in direct proportion to the width.

**SAFE LOAD AT CENTER FOR DOUGLAS FIR PLANK
1½ INCHES THICK (NOMINAL 2 INCH MATERIAL)**

Span in Feet	WIDTH OF PLANK, IN INCHES	
	9½(2 x 10)	11½(2 x 12)
5	334	405
6	278	337
7	239	289
8	209	254
9	185	225
10	168	202
11	151	184
12	141	170

(a) Where the load is distributed over the length of the plank, the safe load in the above table may be doubled.

(4) Two successive lengths of planking shall not abut upon a single supporting putlog or bearer. If planks are laid to abut end to end, 2 parallel bearers or putlogs shall be provided not more than 8 inches apart, so that one putlog will support the end of one plank, and the other putlog the end of the other plank.

(5) Where platform planks overlap, a single bearer or putlog is sufficient, the ends of both the upper and lower planks overlapping the bearer or putlog by at least 6 inches.

(6) Platform planking shall project over the last bearer or putlog by at least 6 inches, but in no case more than 12 inches.

(7) The minimum width of flooring or platforms for scaffolds used for various purposes shall be as follows:

- (a) For use by painters and decorators, inside or outside of buildings and structures ----- 9½ inches
- (b) Where used for men and tools only, and where the platform is not more than 6 feet above the ground or floor, inside or outside of buildings or structures ----- 19 inches
- (c) Where used for men and tools only, where the platform is more than 6 feet above the ground or floor, inside or outside of buildings or structures ----- 23 inches
- (d) Where used for men, materials and tools only -- 46 inches
- (e) Where used for men, materials, tools and vehicles ----- 57 inches

(8) The platforms of all scaffolds shall be solid except that the platform of scaffolds used by painters, decorators, lathers, or plasterers, or similar light work, not more than 12 feet above the floor may have the platform planks or boards spaced not more than 18 inches apart.

(9) Extension plank and toothpick or ladder type plank having the equivalent strength of a solid plank platform may be used by painters and decorators and for similar light work. Such plank shall not be less than 12 inches in width and not more than 25 feet in length. Toothpick or ladder type plank more than 16 feet in length shall have the side rails properly reinforced with steel angles or by a ⅜ inch steel cable running full length under the side rails, securely fastened at each end.

(10) Extension plank used by painters and decorators and for similar light work shall be made of select ladder stock and surfaced on all sides to insure free and easy operation. Sliding bars shall be riveted to a metal holding plate. The ends of the plank shall be rodded to prevent twisting and cracking. Extension plank shall not be more than 2 piece construction and shall be equipped with a locking or blocking device.

RECOMMENDED SPECIFICATIONS

Width	Plank Closed	Plank Open	Stock
10 strips wide	6 feet	10'6"	1½" x 2⅜"
" " "	7 "	12'6"	" "
" " "	8 "	14'6"	" "
" " "	10 "	17'6"	" "

(11) Where scaffolds extend over moving machinery or other dangerous areas, the scaffold platform shall cover or be arranged to adequately guard such machinery or areas.

Ind 35.21 Guard railing and toeboards for scaffolds. (1) A guard railing, as defined in section Ind 35.03, shall be provided on all open sides of all swinging and suspended scaffolds, runways, ramps, rolling scaffolds, elevated platforms or any other elevation 10 feet or more above the ground or floor.

(2) Riveters' platforms, ladder jack and horse scaffolds and single plank painters' scaffolds only are excepted.

(3) A toeboard as defined in section Ind 35.04, shall be provided on the open sides of the platforms of all mason scaffolds, scaffolds on which wheeling is done and other scaffolds where material or tools may slide or be pushed from the working platform. If material on a scaffold is piled higher than the toeboard, $\frac{1}{2}$ inch wire mesh or canvas or equivalent protection shall be provided between the railing and toeboard, and secured top and bottom.

Ind 35.22 Roofing scaffolds. (1) Appropriate support shall be provided for all workmen who are required to work on inclined surfaces having a slope of more than 4 inches rise in 12 inches of horizontal run.

(2) Such support shall consist of foot stops or jack platforms, ladders, chicken ladders, or equivalent devices or construction, anchored to the surface or framework of the roof or other inclined construction in a manner to carry safely, within the limits of stress provided in this code, the maximum load to which the support may be subjected.

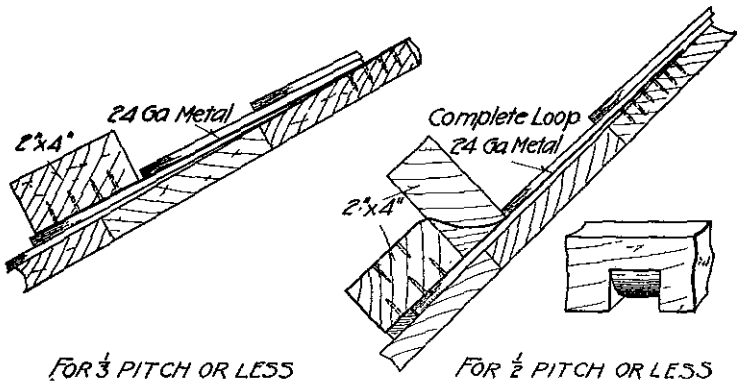

Fig. 11.—Roofing Scaffolds

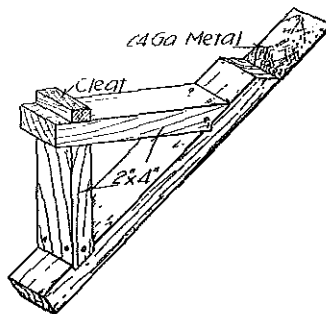

Fig. 12.—Typical jack for roofing scaffold for use where a working platform is desired.

A life line with the fixed end attached to the structure and the free end extending to the ground may be used by painters working on valleys and similar roof areas.

(3) Where foot stops or jack platforms are used, they shall be constructed of not less than 2 x 4 material and secured to the roof surface or structure with 24 gauge metal as shown in the accompanying illustrations.

Ind 35.23 Protection of openings in floors and roofs. (1) Every opening in a floor, or roof, whether such floor or roof is temporary or permanent, shall be enclosed with a guard railing as described in section Ind 35.03 and with toeboards as described in section Ind 35.04. Such railing and toeboards shall be constructed immediately after the floor around the opening is constructed and shall be left in place until the permanent enclosure is installed.

(2) The requirement for guarding a floor or roof opening can be avoided only by closing the opening by means of solid construction as required for scaffold platforms under section Ind 35.13. Such cover shall be fastened in place, or cleated to fit the opening, to prevent shifting.

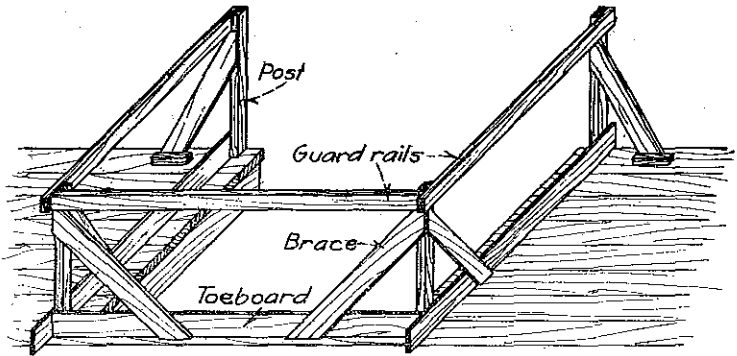

Fig. 13.—Portable Guard Railing

(3) Every runway or scaffold adjoining a floor or roof opening shall have a guard railing and toeboards, as described in sections Ind 35.03 and Ind 35.04, on the side next to the opening.

(4) Where a runway or scaffold is built across any opening, the entire opening shall be completely planked over, unless all open sides of such runway or scaffold are protected with a solid enclosure not less than 3 feet in height.

Ind 35.24 Construction and protection of runways. (1) Every elevated runway shall be built as required for scaffolds, except as otherwise provided in this section.

(2) The floor of every elevated runway shall be constructed of not less than nominal 2 x 10 planks, laid tightly together and secured to the supports by nailing or other means approved by the industrial commission.

(3) The width of every runway floor shall not be less than 19 inches, and where the floor is more than 5 feet above the supporting level the width shall be increased to not less than 28½ inches.

(4) Where used for vehicles, the width of platform and the distance between railings for any runway shall be such that there will be a clearance between railings and vehicle, and between vehicles, of not less than 6 inches for all vehicles used thereon.

(5) A guard railing as defined in section Ind 35.03 shall be provided on runways as follows:

(a) On the open sides of every runway, the floor of which is more than 24 inches above the supporting level.

(b) On the outer side of all runways at turns.

(c) At all openings as in the case of scaffolds.

(6) Toeboards, as defined in section Ind 35.04, shall be provided on the open sides of every elevated runway at all places where the runway floor is 8 feet or more above a work space or similar exposed area.

(7) No runway shall have an incline of more than one foot of vertical rise in 3 feet of horizontal run.

(8) Every runway shall be maintained in safe structural condition while in use, and the floor thereof shall be kept unobstructed and free of objects or material that may cause persons to stumble or slip.

Ind 35.25 Ladders. (1) LADDERS REQUIRED. Where permanent or temporary stairways are not in place or runways are not provided, ladders shall be provided for safe and easy access to elevated working levels and shall be left in place until permanent or temporary stairways are ready for use. Every ladder used under this code shall conform to the definitions set forth in section Ind 35.02.

(2) DESIGN AND CONSTRUCTION OF ALL LADDERS. (a) *Wood ladder.* Every wood ladder shall be designed and constructed to support the maximum load, including weight of materials and persons, within the limits of unit stresses specified in section Ind-53-28 of the Wisconsin state building code.

Note. For a complete specification of wood ladder, see American Standard Safety Code for Wood Ladders sponsored by the American Society of Safety Engineers and approved by the American Standards Association, April 2, 1948.

(b) *Metal ladders.* 1. Ladders constructed of metal shall be the equivalent of wood ladders in strength. Before being used, every metal ladder shall be tested as a simple beam by placing the ladder in a flat, horizontal position, supported at the extreme ends of the side rails. When tested in the above manner, all metal ladders shall sustain for 10 minutes a static load of 200 pounds applied at the center of the rung, located midway between the supports without taking a permanent set or developing any indication of failure.

2. Metal ladders shall not be used in locations where there is danger of the ladder or the person using the ladder coming in contact with conductors carrying electrical current.

(3) *WOOD SIDE RAILS.* Wood side rails shall be made of coast type Douglas fir, Southern yellow pine, Sitka spruce, or wood of equivalent strength and resistance. Wood of other species may be used for the construction of side rails if suitable adjustments are made in the size of the side rails on the basis of the mechanical properties of the

species used. They shall be made of thoroughly seasoned material, free from shakes, decay and other weakening defects. Cross grain in the side rails shall not exceed a slope of one in 12. Checks will be permitted in side rails provided they are not more than 6 inches in length or $\frac{1}{2}$ inch in depth. There shall be no knots in the narrow faces of the side rails. Sound knots not more than $\frac{1}{2}$ inch in diameter will be permitted in the wide faces of the side rails provided they are located not less than $\frac{1}{2}$ inch from either edge of the side rail and are not more frequent than one knot to each 3 feet of ladder length.

(4) RUNGS, STEPS OR CLEATS. (a) Rungs and cleats shall be made of white ash, oak, hickory, or other wood of equal strength. Wood of other species may be used for cleats if suitable adjustments are made in the size of the cleats on the basis of the mechanical properties of the species used. They shall be made of thoroughly seasoned material, free from shakes, decay or other defects. Cross grain shall not exceed a slope of 1 in 15 for rungs or cleats, or 1 in 12 for flat steps. Knots over $\frac{1}{8}$ inch in diameter shall not appear in rungs. Knots in the wide faces of flat steps or cleats shall not exceed $\frac{1}{4}$ inch in diameter. There shall be no knots in the narrow faces of flat steps or cleats.

(b) The rungs, cleats and steps of every ladder shall be of uniform size and spacing, but in no case shall the spacing exceed 14 inches, center to center.

Note. For all new ladders, it is recommended that the spacing of rungs, treads or cleats should not exceed 12 inches, center to center.

(c) Wooden rungs shall be inserted in holes bored along the center line of the wide face of the side rails. The holes shall extend through the side rails or be bored so as to give $1\frac{1}{8}$ inch length of bearing to the rung tenon. In through bored construction, the rungs shall extend through and flush with the outside face of the side rails. The size of the hole shall be such as to insure a driving fit for the rung, with the shoulder forced firmly against the rail and the tenon secured in place by nails.

(d) Wooden cleats shall be housed into the side rails not less than $\frac{1}{2}$ inch, and nailed to each rail with three 10d wire nails, or fastened with through bolts.

(e) Wooden treads shall be inset into the side rails not less than $\frac{1}{8}$ inch and fastened thereto by nails or screws and further secured by braces, bolts, tie rods, or the equivalent.

(5) CLEAT LADDERS. (a) Portable cleat ladders built on the job shall be not more than 24 feet in length and shall conform to the following requirements.

Length in Feet	Inside Width in Inches, [Not Less Than		Minimum Nominal Cross Section, in Inches	
	At Bottom	At Top	Side Rails	Cleats
Not more than 16.....	20	16	2 x 4	1 x 4
More than 16, not more than 24.....	24	20	2 x 6	1 x 4

(b) All wood used in the building of portable cleat ladders on the job and used on only one project shall be 1200# stress grade lumber or better. Wooden cleats shall be nailed to each side rail with at least 3—8d nails or fastened with through bolts.

(6) USE OF LADDERS. (a) When in use, every portable ladder shall have a solid bearing for both stringers at the top and bottom and shall be secured to prevent slipping, such as:

(b) By nailing a cleat to the floor in front of the ladder.

(c) By lashing at top and bottom.

(d) By nailing the feet rigidly to the support.

(e) By installing approved safety shoes.

(f) All ladders bearing against a floor, roof or platform shall extend not less than 3½ feet above such support.

(g) No wood ladder shall be painted with an opaque pigment. Where wood ladders are treated for preservation, a transparent oil or varnish shall be used.

(h) When portable ladders are used, they shall be inclined so that the horizontal distance from the foot of the ladder to a plumb line dropped from the upper point of support is not less than ¼ of the length of the ladder. In case of necessity, where a ladder is inclined less than this, such ladder shall be fastened in place to prevent tipping.

(7) FIXED LADDERS. (a) Fixed ladders shall have parallel sides of either wood or approved metal and shall be firmly secured in place.

(b) When fixed ladders are spliced, the splice plates shall be of metal not less than ¼ of an inch in thickness extending the entire depth of the side rail. The length of the plates shall be at least 4 times the depth of the side rail and all exposed edges shall be chamfered. Splice plates shall be secured by bolts or rivets of not less than ½ inch nor more than ⅝ inch in diameter. A minimum of 3 bolts or rivets shall be used on each side of the joint for metal side rails and a minimum of 4 bolts or rivets for wood side rails. In each case, the bolts or rivets shall be staggered in position and washers shall be provided on wood side rails.

(c) The distance from front of rungs to the nearest permanent object on the climbing side of the ladder shall be not less than 30 inches and the distance from the back of the rungs to the building or structure to which it is fastened shall be not less than 6½ inches. The maximum distance between fastenings or braces shall not exceed 10 feet. The width of a fixed ladder shall not be less than 15 inches from center to center of side rails. In buildings more than 2 stories in height, ladders provided for floor to floor access shall be fixed double ladders.

(d) No ladder, whether fixed or portable, shall be permitted in any hoistway or other shaft in locations exposed to falling objects from operations at higher elevations in, or adjoining, the shaft.

(e) *Landings.* Where landing platforms are provided at the top of fixed ladders, such landing shall be provided with guard railings conforming to the requirements as specified in section Ind 35.03.

(f) Where fixed ladders are used to ascend to heights exceeding 20 feet, landing platforms shall be provided for each 20 feet or fraction thereof, and the ladder sections shall be offset at each platform. Where such offsets are required, the sections shall be joined by the landing platform.

(g) The side rails of fixed ladders shall extend at least $3\frac{1}{2}$ feet above the landing platform, and the upper end shall be goosenecked unless other convenient and secure hand holds are provided at such places. The rungs shall be omitted from this extension, and the top rung shall be at the level or above the adjacent platform and never below.

(8) STEPLADDERS AND TRESTLE LADDERS. (a) Stepladders and trestle ladders over 20 feet in height shall not be used. Extension trestle ladders may be used up to 22 feet in height.

(b) Stepladders shall be so constructed that when in the open position the front section shall have a minimum slope of $3\frac{1}{2}$ inches and the back section a minimum slope of 2 inches for each 12 inch length of ladder side rail. For both stepladders and trestle ladders there shall be a spread at the bottom of the front and back section equal to at least $5\frac{1}{2}$ inches for every foot of length of ladder, including the vertical extension section at the top in the case of extension trestle ladders.

(c) The minimum distance between side rails of stepladders, trestle ladders and the extension section of trestle ladders shall not be less than 12 inches, with a spread of not less than one inch per foot of length of ladder for all stepladders, trestle ladders and bases of extension trestle ladders. The extension section shall have parallel side rails.

(d) A locking device or spreader to hold each of the front and back sections of stepladders and trestle ladders securely in open position shall be an integral part of each ladder. All metal parts shall be malleable iron, wrought iron or steel.

(e) For painter's stepladders, a rope or chain spreader may be substituted for a metal spreader. Rope spreaders shall have sash cord not less than $\frac{1}{8}$ of an inch in diameter or its equivalent. Where chain spreaders are used, the chain shall be of a non-kinking type.

(f) All such ladders shall be secured to prevent slipping by installing approved safety shoes or by some other equally effective method when used on polished or other equally slippery floor surfaces.

(g) Each step of a stepladder shall be reinforced by a metal tie rod or a metal brace.

(h) While in use, every stepladder over 12 feet in height shall be held by an attendant.

(9) EXTENSION LADDERS. (a) No extension ladder shall be used exceeding 60 feet in length when extended and shall have not more than 2 sliding sections. Each sliding section shall be equipped with 2 positive locks of an approved type. Locks and guide irons shall be of such construction as to make the extension ladder of equal strength to a ladder of equal length constructed of continuous side rails.

(b) All parts of the lock shall be of malleable iron, steel or other approved material, except the spring and bushing which shall be of

non-corrosive material. All other metal parts of the ladder shall be of malleable iron, wrought iron, steel or other approved material.

Ind 35.26 Stairs and stair wells. (1) In all buildings, the permanent stairways shall be installed as soon as working conditions will permit.

(2) When work on a building has progressed to a height in excess of 60 feet above the grade, and it has not been practicable to install the permanent stairways, at least one temporary stairway shall be provided for the entire height of the structure, continued upward as the work progresses and shall remain in place until the permanent stairways are installed.

(3) Temporary stairs shall have a pitch of not more than 45 degrees with the horizontal and shall have treads of not less than nominal 2 x 8 material. They shall be not less than 40 inches wide and so constructed that treads and risers are of uniform width and height in any one flight.

(4) No flight of temporary stairs shall have an unbroken vertical rise of more than 12 feet and all intermediate floor landings shall be not less than 30 inches in depth. Where temporary stairs are enclosed, no door shall open directly on the stairs, but there shall be a landing of a width equal to at least the width of the door between the door and the stairs.

(5) All temporary stairs shall be so constructed as to be able to support a live load of at least 100 pounds per square foot of tread and landing surface.

(6) On permanent stairways designed and installed with steel treads and landings to receive cement or other filling material, temporary wooden treads shall be laid in the full width of the tread and landing to the height of the nosing, firmly fitted in and secured in place. Such wooden treads shall be free from protruding nails and splinters and shall be replaced when any part of the same is worn below the height of the nosing.

(7) All stairways, whether temporary or permanent, shall be provided with at least one handrail and where open on both sides, shall have a handrail on each side. Where only one handrail is required, it shall be placed on the left hand side as one mounts the stairs, or on the open side, if any. Rails shall not be less than 2 feet 6 inches vertically above the nose of treads or 3 feet 6 inches above the platform. Railings on open sides of stairways and platforms shall be provided with an intermediate member at mid height. Toeboards conforming to the requirements of section Ind 35.04 shall be provided on the open sides of all platforms.

Ind 35.27 Temporary floors. (1) In buildings or other structures being erected with steel construction, the permanent floor filling (except for temporary shaftway openings) shall be installed as the erection progresses or a temporary plank floor shall be provided not less than 2 tiers below the tier of beams on which bolting, riveting, welding, or painting is being done. Such temporary floor shall cover the entire tier of beams except for such places as are required for access to ladders and stairways and for hoisting purposes.

(2) In buildings or other structures of reinforced concrete construction, the floors shall be filled in, either with forms or concrete, on each floor before the starting of work upon the walls of the second floor above, or the starting of work upon the next floor above.

(3) In buildings or other structures of wood joist floor construction, the underflooring shall be laid on each tier of joists as the structure progresses, or if double floors are not to be used, the tier of joists next below where work is being performed shall be entirely floored over except for such spaces as are required for ladders and shaftways. The temporary flooring shall consist of boards not less than nominal one inch in thickness.

(4) Planks shall, in each case, be laid close together with all ends over solid bearing and the ends overlapped at least 4 inches. They shall be clean and free from projecting nail points or splinters and not less than nominal 2 inches thick with a maximum span of 10 feet.

Ind 35.28 Elevators for workmen. (1) When a permanent or temporary elevator car is put in use for carrying workmen, the hoistway shall be completely enclosed for its entire height. If such an enclosure is permanent, it shall comply with the requirements of the elevator code issued by the industrial commission. All openings into the hoistway shall be enclosed with self-latching doors locked on the hatchway side, and only opened on the outside by a key kept in the possession of an authorized person, and control shall be so arranged that the car cannot travel while a landing or car door is open.

(2) All hoistway doors and car doors and gates shall be equipped with mechanical or electrical interlocks which will prevent the movement of the car when any door or gate is open.

(3) The car shall be enclosed on all sides except at the entrance which shall be provided with a door or gate which is kept closed while the car is in motion.

(4) The top of each elevator car shall be provided with a strong substantial cover, opened only from the inside of the car. The cover shall be made in sections which shall be hinged and arranged to swing upward when handling long material, but such cover shall be kept closed at all other times.

(5) An electrical push button signaling device or other approved signaling system shall be provided at each floor landing and connected to an annunciator in the car.

(6) The machinery and equipment of such elevators, as well as any other part of the installation which is permanent, shall comply with the requirements of the elevator code issued by the industrial commission.

(7) The elevator machine and controls shall be housed in as a protection against accidents and the weather, and the entrance kept locked against unauthorized entrance.

(8) The car shall be in charge of a competent operator.

Ind 35.29 Material hoists. (1) **INSIDE MATERIAL HOIST SHAFTWAYS.** (a) All material hoist shaftways erected inside of buildings shall preferably be enclosed tightly their entire length. When this is not practicable, the sides of the shaftway not used for entrances shall be enclosed on each floor to a height of at least 8 feet with not less than number 16 U. S. gauge wire netting, 1½ inch mesh, or enclosed with wooden slats spaced vertically not more than 4 inches apart,

with a toeboard conforming to the requirements of section Ind 35.04 around all sides except the entrance. Where two material shaftways are erected side by side, similar protection shall be placed between them. The enclosure shall extend at least 2 feet in front of the shaftway unless the entrances are protected by gates.

(b) The entrance to the shaftway at the main loading floor shall be guarded with an automatic sliding gate and at all other floors with hand raised sliding gates at least 6 feet high and with the bottom of the gate not more than 2 inches off the floor.

(c) The guide rails shall be of sound lumber or steel, of adequate uniform size to provide a firm track, and shall be kept rigid and in perfect alignment at all times.

(d) Overhead sheave beams and their supports shall be of good sound timber, or of steel, designed with a factor of safety of not less than 5 to support the maximum combined dead and live loads which will be imposed.

(e) A protective covering of planking or heavy wire netting shall be provided above the overhead work of all hoists to prevent objects falling down the shaftway.

(2) HOISTING TOWERS. (a) Material hoist towers, whether erected inside or outside of buildings, shall be constructed of strong, sound material and designed with a factor of safety of not less than 5 to carry the maximum intended loads. Level foundations shall be provided of sufficient size so that the allowable bearing capacity of the soil will not be exceeded. Posts and connections, if of wood, shall conform to the following minimum dimensions:

Car Capacity Pounds	Nominal Size of Corner Posts		Nominal Size of Horizontal Ties		Nominal Size of Bracing
	Height in Feet		Size	Vertical Spacing	
	Less Than 100	100 or more			
Not more than 500--	4 x 4	4 x 4	2 x 6	6	2 x 4
500 to 1000-----	4 x 4	4 x 6	2 x 6	6	2 x 4
1000 to 2000-----	4 x 4	6 x 6	2 x 8	8	2 x 6
2000 to 4000-----	4 x 6	8 x 8	2 x 8	8	2 x 6

(b) Except that where the height of a hoist tower does not exceed 60 feet, and the car capacity is less than 2,000 pounds, the ties may be reduced to nominal 2" x 6" and the braces to nominal 1" x 8".

(c) All splices in posts shall be not less than 2 inches in thickness, 4 feet long, and shall be spiked or bolted to at least 2 adjacent sides of the posts. All splices shall be staggered.

(d) Each hoist tower shall be securely guyed and well anchored and shall be provided with a fixed ladder conforming to the requirements of section Ind 35.25, extending the entire length of the tower.

(e) Hoist towers shall be enclosed on all sides at the loading and unloading levels to a height of at least 6 feet, with number 16, U. S. gauge wire screen with 1½ inch mesh, or with other material that will provide the equivalent safety. The entrances to the enclosure at

the loading and unloading levels shall be protected with gates at least 6 feet high and the bottom not more than 2 inches off the floor or with other devices that will provide the equivalent in safety. Platforms and runways shall be constructed and guarded as required for scaffolds under sections Ind 35.20 and Ind 35.21.

(f) The overhead framework of all towers shall be of sufficient strength to support the total maximum load of all sheaves, car and material to be hoisted, with a factor of safety of 5.

(3) MATERIAL HOIST PLATFORMS. (a) Material hoist platforms shall be constructed of materials conforming to the provisions of section Ind 35.12 and shall be designed with a factor of safety of 5 for the maximum load to be carried.

(b) Overhead protective covering of planking or heavy wire mesh shall be provided on the cross-head of every material hoist platform. The protection on the cross-head shall be made in sections and each section hinged where long material is to be hoisted.

(c) Suitable blocking and cleats shall be provided on all platforms when wheelbarrows or other rolling pieces of equipment are transported to hold them securely in place.

(d) The platforms of every hoist shall be enclosed on all sides, where openings are not to be left, with toeboards and a wire screen enclosure of not less than number 16 U. S. gauge wire with 1½ inch mesh.

(e) Workmen shall not be permitted to ride on material hoists and a sign prohibiting this practice shall be posted on the shaftway enclosure at each floor opening. This requirement does not apply to mechanics when making repairs or servicing the hoist.

(4) ROPE AND SHEAVES. (a) Wire rope not less than ¾ inch in diameter shall be used as the hoisting medium for all mechanical powered hoists and shall conform to the requirements of section Ind 35.32.

(b) The sheaves and drums for all hoists shall be of steel or cast iron, except that lining (or lagging) may be of hardwood, and their diameters shall be not less than the following:

Diameter of Hoisting Rope in Inches	Diameter of Sheave or Drum in Inches (at bottom of groove)	Diameter of Axle in Inches
¾	12	1- ³ / ₁₆
1½	12	1- ³ / ₁₆
5⁄8	14	1- ¹ / ₈
¾	16	1- ¹¹ / ₁₆
7⁄8	18	1- ¹⁵ / ₁₆
1	20	2- ³ / ₁₆

(5) **HOISTING ENGINES.** (a) Hoisting engines shall be equipped with brakes capable of stopping and sustaining 150% of the maximum load in any position. A pawl shall be used in addition to the brake to hold the load when it is suspended, but a pawl or any other similar substitute contrivance will not be acceptable without the required brake as specified herein.

(b) All gearing on hoisting engines shall be completely enclosed, and all hoisting cables within 7 feet of any working level shall be completely enclosed or so guarded as to prevent persons coming in contact with the cables.

(c) Every hoisting machine shall be so arranged or equipped that the location of the car or platform at any stopping position is accurately indicated to the operator.

Ind 35.30 Derricks. (1) Derricks shall be constructed of sound, seasoned lumber, with proper iron or steel braces and fittings, or entirely of steel. They shall be designed and constructed in a manner such that the unit stresses in the material of any part of the derrick, when under maximum loading, will not exceed those specified for that material under chapter 5 of the state building code issued by the industrial commission.

(2) The foot block or support for any derrick shall be anchored or firmly secured to prevent slipping or tipping under any load condition.

(3) The top of the mast on guy derricks shall have at least 6 guy cables equally spaced.

(4) The requirements for rope and sheaves described in section Ind 35.29 (4) for material hoists shall also apply to derricks.

Ind 35.31 Operation of hoists and derricks. (1) No person shall be permitted to be lifted by, carried by or to ride on, any material hoist or derrick, with or without other load.

(2) Bell, whistle or electric signals shall be provided for all material hoists where an operator is stationed at the power device and for all derricks except where the operator has a clear and unobstructed view of the load or signalman, in which case a manual system of signaling may be used.

(3) The signal code shall be posted adjacent to the signal device at each work level and at the operator's position.

Ind 35.32 Fibre and wire rope. (1) **FIBRE ROPE.** (a) All fibre rope used for hoisting purposes of any kind or for the support of scaffolds or any part thereof shall be of a high grade of long fibred Manila hemp. (abaca)

(b) All such fibre rope used for the support of scaffolds, or any part thereof, except rope used for lashing and tying purposes, shall be not less than $\frac{3}{4}$ inch in diameter.

(c) The maximum safe working load for fibre rope shall not exceed $\frac{1}{6}$ of the maximum strength (breaking load). The safe work-

ing loads for high grade Manila rope based on data furnished by the Bureau of Standards are as follows:

Approximate Diameter, in Inches	Circumference, in Inches	Safe Load, in Pounds
$\frac{3}{16}$ (6 yarns) -----	$\frac{1}{2}$	98
$\frac{1}{4}$ (6 yarns) -----	$\frac{3}{4}$	116
$\frac{5}{16}$ (9 yarns) -----	1	200
$\frac{3}{8}$ (12 yarns) -----	$1\frac{1}{8}$	241
$\frac{1}{2}$ (15 yarns) -----	$1\frac{1}{4}$	291
$\frac{5}{8}$ (18 yarns) -----	$1\frac{3}{8}$	350
$\frac{3}{4}$ (21 yarns) -----	$1\frac{1}{2}$	408
$\frac{7}{8}$ -----	$1\frac{3}{4}$	526
$\frac{15}{16}$ -----	2	666
1 -----	$2\frac{1}{4}$	816
$1\frac{1}{8}$ -----	$2\frac{1}{2}$	983
$1\frac{1}{4}$ -----	$2\frac{3}{4}$	1,166
$1\frac{1}{2}$ -----	3	1,366
$1\frac{3}{4}$ -----	$3\frac{1}{4}$	1,688
2 -----	$3\frac{1}{2}$	1,833
$2\frac{1}{4}$ -----	$3\frac{3}{4}$	2,083
$2\frac{1}{2}$ -----	4	2,365
$2\frac{3}{4}$ -----	$4\frac{1}{4}$	2,666
3 -----	$4\frac{1}{2}$	2,916

Note. If for any reason Manila fibre rope is not available, ropes of other fibres may be used upon submission of data from the U. S. Bureau of Standards covering the breaking strength thereof to the industrial commission for approval.

(2) WIRE ROPE. (a) The maximum safe working load for all wire rope used for any purpose covered by this code shall not exceed 1/6 of the breaking load as determined by the manufacturers.

Note. The table on page 35 shows the maximum safe working loads as provided in this section for wire rope of various construction and material as produced by one manufacturer. The purpose of this table is only to show approximate limitations of wire rope capacity. The actual safe load for any rope must be based on the breaking load as determined by the manufacturer of the rope being used.

(b) A wire rope is considered unsafe and shall be renewed when through broken wires, wear, rust, undue strain, or other cause, the strength of the rope becomes reduced 25%. Any wire rope showing 10% of its wires broken in a 3 foot length shall not be used.

(c) Wire rope shall be kept lubricated with a lubricant recommended by the rope manufacturer.

(3) USE OF FIBRE AND WIRE ROPE. (a) Where the bearing for any fibre or wire rope fastening has a diameter less than 2 times the diameter of such rope, the loop passing around the anchorage shall be lined with a thimble to prevent chafing or abrading of the rope at the bearing.

SAFE WORKING LOAD, IN POUNDS, FOR TYPICAL WIRE ROPE
Wire Rope Construction and Material

Diameter of Rope, in Inches	6x7			6x19			6x37			8x19			6x7 or 6x19 Cast Steel Guy Rope	6x7 or 6x19 Iron Guy Rope
	Cast Steel	Mild Plow Steel	Plow Steel	Cast Steel	Mild Plow Steel	Plow Steel	Cast Steel	Mild Plow Steel	Plow Steel	Cast Steel	Mild Plow Steel	Plow Steel		
¼	-----	-----	-----	730	810	880	-----	-----	730	600	670	750	-----	330
⅜	1160	1310	1460	1030	1160	1260	-----	-----	1130	910	1010	1110	1060	470
½	1530	1750	1960	1600	1760	1910	1400	1550	1700	1400	1550	1700	1400	650
⅝	1830	2080	2330	2160	2410	2660	1830	2110	2400	1900	2100	2300	1660	780
¾	2560	2950	3330	2800	3060	3330	2410	2750	3080	2460	2660	2900	2330	1130
⅞	3330	3660	4000	3330	3730	4100	3160	3500	3860	2900	3360	3860	3000	1430
1	4330	4830	5330	4160	4660	5160	3760	4200	4660	3660	4130	4660	3900	1900
1 ¼	6200	7000	7660	5830	6730	7660	5830	6330	7000	5100	5860	6660	5600	2600
1 ½	8000	9330	10330	7660	8660	9660	7660	8330	9000	6660	7660	8660	7330	3700
1 ¾	10330	11660	12660	10000	11330	14660	9660	10660	11660	8660	9900	11000	9330	4700

INDUSTRIAL COMMISSION

(b) Where any fibre or wire rope comes in contact with a rough surface or sharp edge, a smooth frictionless guard shall be provided at all points of contact to prevent injury to the rope.

(c) Fibre rope fastenings shall be by means of knots such that the free end will not have a tendency to slip. The free end of all knots shall be served to prevent untwisting and loosening of the fibres.

(d) Wire rope fastenings, except for elevators for workmen, shall be secured by clips, using not less than 3 clips to fasten the free end to the standing portion of the rope, or shall be fastened as required by the elevator code. Where clips are used, the U shall be placed on the dead end of the rope.

(e) Every rope subject to load strain shall be maintained straight, without bends or turns, except where proper pulleys or sheaves are provided to accomplish the change in direction.

(f) Fibre rope supporting a scaffold, where acid is used, shall be protected by an acid resisting shield. Fibre rope that has been exposed to acid shall be tested each day, and if found to be damaged by the acid, shall not be used. Rope shall not be stored in the same place with acid containers.

Ind 35.33 Protection from falling objects. (a) Every hoisting engine, air compressor, concrete mixer or other machine used in construction work and which requires an attendant, shall be covered over to protect the operators stationed at the machine, wherever the horizontal distance from such machine to the nearest point where work is being done is less than one-half the vertical height of such point above the machine. The covering shall be solid, shall extend not less than 4 feet outside the normal working area of the machine operators, and shall be constructed to support a uniform load of not less than 30 pounds per square foot over the entire covering, in addition to the weight of the covering itself.

(b) When men are working in an elevator shaftway, hatchway or stair well during the construction, demolition or alteration to any structure, a protection shall be provided not more than 2 stories above nor more than one story below the level at which the men are working. Such protection shall be solid and shall be of not less than nominal 2 inch plank.

(c) All material and other objects on upper levels shall be kept at least 6 feet away from any shaftway, except where a solid enclosure is provided.

Ind 35.34 Slippery conditions. (1) No structural metal on which the paint or other protective covering has not dried sufficiently to present a non-slippery surface shall be erected or placed in any structure.

Note. Paint that can be smeared or broken by light rubbing cannot be considered dry and non-slippery.

(2) No person shall work on the surface of any structural member, floor or other working platform which has become slippery from ice, snow, frost, painting or other cause, unless such surface is cleaned, sprinkled with sand or made non-slippery insofar as the nature of the work will reasonably permit.

History: 1-2-56; am. Register, January, 1963, No. 85, eff. 2-1-63.

Ind 35.35 Storage of materials. (1) **LUMBER.** Lumber shall be piled level on solid supports and shall be not less than 4 vertical tiers wide. When piled more than 4 feet high, all lumber shall be cross-piled.

(2) **CEMENT, LIME AND PLASTER.** Bags of cement, lime, plaster, or other similar materials shall not be piled more than 10 bags high unless stored in bins or enclosures built for the purpose of storage. Where piled more than 5 feet high, the faces of the pile shall be tapered back so as to form an angle of not more than 60 degrees with the horizontal, or shall be cross-piled in each horizontal layer to prevent falling or collapsing.

(3) **BRICK, TILE AND BLOCK.** Brick, tile, concrete block and similar material shall not be piled more than 6 feet high. When a pile reaches the height of 4 feet, it shall be stepped back on all sides so as to form an angle of not more than 60 degrees with the horizontal.

(4) No material or objects shall be stored less than 6 feet from the outside edge of any floor, any side of any court or floor opening or from the side of any excavation, except where a solid wall or fence not less in height than the piled material has been provided to prevent anything from falling over the edge, and except material being used at such outside edge.

Cross Reference. See general orders on explosives and the flammable liquids code, both issued by the industrial commission, for requirements applying to the storage of explosives and flammable liquids.

Ind 35.36 Storage or disposal of debris. (1) All boards, planks, blocks and other material and debris containing projecting nails, waste clippings or cuttings of lumber, metal (including pieces of sheet metal, pipe, metal lath, rolled shapes, wire), masonry materials and similar objects, shall be removed from the working area or shall be placed in orderly piles where workmen will not be likely to step on, stumble over or fall on them.

(2) Oily rags and similar debris fire hazards shall not be permitted to accumulate on a project, but shall be destroyed immediately.

Ind 35.37 Electrical hazards. (1) **PROTECTION FROM ADJOINING POWER AND LIGHT LINES.** No part of a structure in progress of erection, including accessory scaffolds, towers, power equipment, booms and other fixed and movable equipment constructed or used in connection with a construction project, shall extend nearer to conductors carrying electrical current than the distance indicated in the following table:

Voltage of Conductors	Minimum Vertical Clearance at Conductors	Minimum Lateral Clearance, in Feet	
		Bare Conductors	Insulation Covered Conductors
300 or less.....	8	3	3
More than 300 to 750.....	8	3	3
More than 750 to 7500.....	10	10	10
More than 7500.....	10 plus 1/10 foot for each 1000 volts over 7500	10 plus 1/10 foot for each 1000 volts over 7500	10 plus 1/10 foot for each 1000 volts over 7500

(a) By "insulation" is meant as defined in the Wisconsin state electrical code.

Cross Reference. See section 134.40, Wis. Stats., regarding "Injury to Wires by Removal of Building, etc."

Note. In every case where work is to be done in close proximity to current carrying conductors, the operator of such conductors should be notified in writing.

(2) **GROUNDING.** Where equipment is connected to a source of electrical power, all metal or other current conducting, but non-current carrying, parts shall be grounded. In the case of electric hoists, the friction levers, controller handles, foot brakes and other non-current carrying parts shall be grounded.

(3) **EQUIPMENT USED IN VICINITY OF CONDUCTORS TO BE GROUNDED.** All parts of equipment, such as steam shovels, derricks and similar machinery and devices, which are moved or put in use in the vicinity of conductors carrying electrical current, shall be grounded so far as practicable.

(4) **PROVISIONS OF ELECTRICAL CODE TO GOVERN.** Every ground shall be made in accordance with the provisions of the Wisconsin state electrical code.

Ind 35.38 Illumination. (1) Natural or artificial illumination shall be provided during the progress of construction at the head and foot of all stairs and ladders which are open to use, at all openings in floors, at all elevator and hoist landings, and at all power and other moving equipment. The following intensities of illumination in foot-candles, shall be considered a minimum for the locations specified:

(a) At the head and foot of stairs and ladders -----	1.0
(b) At openings in floors -----	1.0
(c) At woodworking and other operative machines -----	5.0
(d) At moving power equipment not requiring operators or attendants -----	2.0
(e) At elevator and hoist landings -----	2.0

(2) The requirements of the industrial lighting code issued by the industrial commission shall apply under this code so far as possible and practical.

(3) The requirements of this section shall apply during all hours of employment, including one-half hour before and one-fourth hour after the regular hours, and shall apply to all working areas on the site of any project which comes within the scope of this code.

Ind 35.39 Toilets. On every project which comes within the scope of this code, one privy or toilet shall be provided for every 20 persons, or fraction thereof, employed on any one shift. Toilet facilities shall be shielded from view, protected against the weather and falling objects, and maintained as sanitary as local conditions will permit. A sufficient supply of toilet paper shall be provided at all times in each toilet room or privy.

Ind 35.40 Drinking water. (1) Sufficient pure drinking water shall be provided for workmen on every project covered by this code. Common drinking cups or dippers are prohibited.

(2) Where running water is not available, a covered drinking water container shall be provided. The container shall be cleaned and sterilized at frequent intervals and kept in a sanitary condition and in good repair.

Ind 35.41 Protection of machine operators from the weather. From November 1 to April 1, all hoisting machines that require continuous attendance while in use shall be housed in to protect the operators from the weather. This section does not apply to machines used on a job for not more than 3 days.

Ind 35.42 Inspection and maintenance. (1) All equipment and construction included in this code shall be maintained to the standards prescribed herein.

(2) Inspections shall be made by a foreman or other designated responsible workman with sufficient frequency to insure complete investigation of the condition of all such equipment and construction. Equipment or construction which has not been in use for a period of 30 days or more shall be inspected as above before being used. Where any equipment or construction, or part thereof, has become weakened in any respect, the same shall not be used until it is made to conform with the provisions of this code.

GENERAL NOTE

The requirements of the general orders on safety issued by the industrial commission apply to machinery and similar equipment used on projects within the scope of this code.

The general orders on dusts, fumes, vapors and gases issued by the industrial commission apply to operations where there is exposure to harmful dusts, fumes, vapors and gases, such as those produced by salamanders, sanding, grinding, sand blasting, etc.

The general orders on spray coating apply to all spray coating operations in, and on, buildings and structures.