

Chapter ILHR 33

TRAMWAYS, LIFTS AND TOWS

Subchapter I		Subchapter V	
SCOPE-APPLICATION-DEFINITIONS		AERIAL LIFT SYSTEMS	
ILHR 33.001	Purpose (p. 1)	ILHR 33.40	Application (p. 21)
ILHR 33.002	Scope (p. 2)	ILHR 33.41	Design requirements (p. 21)
ILHR 33.003	Saving and severable clause (p. 2)	ILHR 33.42	System location and clearances (p. 30)
ILHR 33.004	Application (p. 2)	ILHR 33.43	Loading and unloading areas (p. 31)
ILHR 33.01	Definitions (p. 3)	ILHR 33.44	Towers (p. 32)
Subchapter II		ILHR 33.45	Carrier speeds (p. 33)
ADMINISTRATION & ENFORCEMENT		ILHR 33.46	Manual and automatic stops (p. 34)
ILHR 33.02	Application (p. 5)	ILHR 33.47	System operations (p. 35)
ILHR 33.03	Department review (p. 5)	ILHR 33.48	Signs (p. 35)
ILHR 33.04	Notification of alterations (p. 6)	Subchapter VI	
ILHR 33.05	Petition for variance (p. 6)	SURFACE LIFT SYSTEMS	
ILHR 33.06	Department inspections (p. 7)	ILHR 33.60	Application (p. 36)
ILHR 33.07	Owner's responsibility (p. 8)	ILHR 33.61	Design requirements (p. 36)
ILHR 33.08	Fees (p. 8)	ILHR 33.62	System location and clearances (p. 40)
ILHR 33.09	Penalties (p. 8)	ILHR 33.63	Loading and unloading areas (p. 41)
Subchapter III		ILHR 33.64	Towers (p. 41)
GENERAL REQUIREMENTS		ILHR 33.65	Carrier speeds (p. 41)
ILHR 33.10	Application (p. 8)	ILHR 33.66	Manual and automatic stops (p. 42)
ILHR 33.11	Design passenger weight (p. 8)	ILHR 33.67	System operations (p. 42)
ILHR 33.12	Towers and structures (p. 9)	ILHR 33.68	Signs (p. 43)
ILHR 33.13	Power sources (p. 9)	Subchapter VII	
ILHR 33.14	Machine guarding (p. 10)	ROPE TOW SYSTEMS	
ILHR 33.15	Wire ropes, cables and strands (p. 10)	ILHR 33.80	Application (p. 43)
ILHR 33.16	Maintenance (p. 10)	ILHR 33.81	Design requirements (p. 43)
ILHR 33.17	Accidents and evacuation (p. 10)	ILHR 33.82	Tow path, clearances and location (p. 46)
ILHR 33.18	Communications (p. 11)	ILHR 33.83	Loading and unloading areas (p. 47)
Subchapter IV		ILHR 33.84	Towers (p. 47)
AERIAL TRAMWAYS		ILHR 33.85	Haul rope speeds (p. 47)
ILHR 33.20	Application (p. 11)	ILHR 33.86	Manual and automatic stops (p. 47)
ILHR 33.21	Design requirements (p. 11)	ILHR 33.87	System operations (p. 48)
ILHR 33.22	System location and clearances (p. 18)	ILHR 33.88	Signs (p. 49)
ILHR 33.23	Loading and unloading areas (p. 19)	Subchapter VIII	
ILHR 33.24	Towers (p. 19)	INCORPORATION OF	
ILHR 33.25	Carrier speeds (p. 20)	STANDARDS BY REFERENCE	
ILHR 33.26	Manual and automatic stop switches (p. 20)	ILHR 33.90	Incorporation of standards by reference (p. 49)
ILHR 33.27	System operations (p. 21)		

Note: Ch. Ind 46 as it existed on June 30, 1984 was repealed and a new chapter ILHR 33 was created effective July 1, 1984.

SUBCHAPTER I

SCOPE-APPLICATION-DEFINITIONS

ILHR 33.001 Purpose. Pursuant to ss. 101.02 (1) and 101.17, Stats., the purpose of this chapter is to protect the health, safety and welfare of the public and employes by establishing minimum design, construction, in-

stallation and operation standards for aerial tramways, aerial lifts, surface lifts and rope tows.

History: Cr. Register, June, 1984, No. 342, eff. 7-1-84.

ILHR 33.002 Scope. This chapter applies to all locations where aerial tramways, aerial lifts, surface lifts and rope tows are installed, constructed, altered or operated.

History: Cr. Register, June, 1984, No. 342, eff. 7-1-84.

ILHR 33.003 Saving and severable clause. If, for any reason, any one or more sections, sentences, clauses or parts of this chapter are held invalid, such invalidity shall not affect, impair or invalidate the remaining provisions.

History: Cr. Register, June, 1984, No. 342, eff. 7-1-84.

ILHR 33.004 Application. (1) **NEW INSTALLATIONS.** The provisions of this chapter shall apply to all aerial tramways, aerial lifts, surface lifts and rope tows installed or constructed after the effective date of this chapter.

(2) **ALTERATIONS.** The provisions of this chapter shall apply to all alterations of and additions to an aerial tramway, aerial lift, surface lift or rope tow which affect a system's design, structural strength or operation or which replace any piece of major equipment on a system. The provisions of this chapter do not apply to minor repairs necessary for a system's maintenance.

(3) **EXISTING INSTALLATIONS.** Except as specified in pars. (a) and (b), the provisions of this chapter shall not apply to those aerial tramways, aerial lifts, surface lifts and rope tows installed or constructed prior to the effective date of this chapter.

(a) The sections listed in Table 33.004 shall apply to those systems existing prior to the effective date of this chapter.

**Table 33.004
RETROACTIVE PROVISIONS**

1. ILHR 33.06(2)	13. ILHR 33.41(1), except par.(b)2.	24. ILHR 33.64
2. ILHR 33.15	14. ILHR 33.41(8)(c)	25. ILHR 33.65
3. ILHR 33.16	15. ILHR 33.41(9)(c)	26. ILHR 33.67
4. ILHR 33.17	16. ILHR 33.42(1)and(2)	27. ILHR 33.68
5. ILHR 33.18	(a),(c)and(d)	28. ILHR 33.81(2)(a)4.
6. ILHR 33.21(1)(c)	17. ILHR 33.44	29. ILHR 33.81(5)(b)2.
7. ILHR 33.21(8)(c)	18. ILHR 33.45	30. ILHR 33.82(1)(c)
8. ILHR 33.21(9)(c)	19. ILHR 33.46(3)(b)5.a.	31. ILHR 33.84
9. ILHR 33.21(11)(a)7. and 8.	20. ILHR 33.47	32. ILHR 33.85
10. ILHR 33.22(1)and(2)	21. ILHR 33.48	33. ILHR 33.87
11. ILHR 33.24	22. ILHR 33.61(2)(a)3.	34. ILHR 33.88
12. ILHR 33.27	23. ILHR 33.61(7)(c)	

(b) On July 1, 1989, the sections listed in subds. 1. to 4. shall apply to those systems existing prior to the effective date of this chapter:

1. ILHR 33.22 (4) (b);

2. ILHR 33.42 (4) (b);

Register, June, 1984, No. 342

3. ILHR 33.62 (3) (b); and

4. ILHR 33.82 (3).

History: Cr. Register, June, 1984, No. 342, eff. 7-1-84.

ILHR 33.01 Definitions. In this chapter:

(1) "Aerial lift" means that class of conveyance system in which people are transported in carriers which circulate around a closed system activated by a wire, rope or chain, and wherein the passengers are not in contact with the ground or snow surface. Types of aerial lifts are:

(a) "Chairlifts" means that type of aerial lift wherein the passengers are transported in either open or partially enclosed chairs.

(b) "Gondola lifts" means that type of aerial lift wherein the passengers are transported in open or enclosed cabins.

(2) "Aerial tramway" means that class of conveyance system in which people are transported in carriers which reciprocate between terminals and wherein the passengers are not in contact with the ground or snow surface. Types of aerial tramways are:

(a) "Single tramways" means that type of aerial tramway having a single carrier, or single group of carriers, which moves back and forth between terminals on a single path of travel.

(b) "Double tramways" means that type of aerial tramway having 2 carriers, or 2 groups of carriers, which oscillate back and forth between terminals on 2 paths of travel.

(3) "Approved" means acceptable to the department.

(4) "Carrier" means that part of an aerial tramway, aerial lift, surface lift or rope wire tow on which or in which people are transported or ride.

(5) "Department" means the department of industry, labor and human relations.

(6) "Designated" means as determined or indicated by the owner or operator of an aerial tramway, aerial lift, surface lift or rope tow.

(7) "Evacuation" means an emergency unloading procedure to remove passengers at other than designated unloading areas.

(8) "Haul rope" means a fiber or wire rope which propels equipment or people.

(9) "Monocable system" means a conveyance system using a moving haul rope to both support and control motion of its carriers.

(10) "Multicable system" means a conveyance system using separate cables to support and control the motion of its carriers.

(11) "Path" means that area of a surface lift system or rope tow system traversed by a user which extends between the loading area and the point beyond the safety gate for the unloading area where a passenger would disembark if the safety gate was actuated.

(12) "Rope" means a cord consisting of several strands twisted or braided together. Types of ropes are:

(a) "Fiber rope" means a rope made from natural or synthetic strands; and

(b) "Wire rope" means a rope made from metallic strands with or without a core of synthetic or fiber material.

(13) "Rope tow" means that class of conveyance system by which people grasp a circulating haul rope or a fixed handle attached to the circulating haul rope, and are pulled by the circulating haul rope while remaining in contact with the ground or snow surface. The upward-traveling haul rope remains adjacent to the uphill track of the users and at an elevation that permits them to maintain their grasp on the haul rope or fixed handle throughout the portion of the tow length that is designed to be traveled. Types of rope tows are:

(a) "Fiber rope tow" means that type of tow having a fiber haul rope; and

(b) "Wire rope tow" means that type of tow having a wire haul rope.

(14) "Safety gate" means a type of automatic stop switch which is actuated by a passenger's weight, contact or passage.

(15) "Safety stop switch" means a device to stop an aerial tramway, aerial lift, surface lift or rope tow as a result of passenger contact, an attendant's action, haul rope deropement, cable derailment or movement of a terminal sheave or counterweight.

(16) "Sheave" means a pulley or wheel grooved for rope. Types of sheaves include:

(a) "Counterweight sheave" means a sheave which is used in the counterweight system and which is active during the system's operation.

(b) "Drive sheave" means a bull wheel which propels a system's haul rope.

(c) "Haul rope sheave" means a sheave that supports or holds down a system's haul rope at towers or terminals.

(d) "Return sheave" means a bull wheel which reverses the direction of travel, but does not transmit power to the haul rope.

(e) "Terminal sheave" means a haul rope sheave which rotates continuously when the haul rope is moving and which deflects the haul rope by an angle of 10° or more. Types of terminal sheaves are:

1. "Bull wheel" means a sheave which deflects the haul rope 150° or more; and

2. "Deflection sheave" means a sheave which is used for the primary function of changing the course of direction of the haul rope more than 10° but less than 150°.

(17) "Surface lift" means that class of conveyance system by which people are moved by means of a circulating overhead wire rope while remaining in contact with the ground or snow surface. Types of surface lifts are:

(a) "J-bar lift" means that type of surface lift where the device between the haul rope and the user is in the general form of the letter "J", moving a single user located on the one side of the stem of the "J".

(b) "Platter lift" means that type of surface lift where the device between the haul rope and the user is a single stem with a platter or disk attached to the lower end of the stem, moving the user astride the stem of the platter or disk.

(c) "T-bar lift" means that type of surface lift where the device between the haul rope and the users forms the shape of an inverted letter "T", moving users located on the sides of the stem of the "T".

(18) "System" means a mode of conveyance for moving people. Types of systems are:

(a) Aerial tramways;

(b) Aerial lifts;

(c) Surface lifts; and

(d) Rope tows.

(19) "Track cable" means a fixed cable or rope which supports a moving load.

(20) "Track cable saddle" means a component designed to directly support a track cable.

History: Cr. Register, June, 1984, No. 342, eff. 7-1-84.

SUBCHAPTER II ADMINISTRATION & ENFORCEMENT

ILHR 33.02 Application. The requirements in this subchapter shall apply to all aerial tramways, aerial lifts, surface lifts and rope tows.

History: Cr. Register, June, 1984, No. 342, eff. 7-1-84.

ILHR 33.03 Department review. (1) **PLANS AND SPECIFICATIONS.** Before the construction, erection or relocation of or addition to an aerial tramway, aerial lift, surface lift or rope tow may commence, plans and specifications for the proposed system shall be submitted to the department for review and plan approval shall be obtained from the department.

Note: See Appendix for further explanatory material.

(a) At least 3 copies of the system's plans which are clear, legible and permanent copies and one copy of specifications shall be submitted to the department.

Note: Original drawings are not considered a substitute for permanent prints.

(b) Plans shall include the following applicable information:

1. Name of the owner and the location of the system;
2. Name and address of the system's designer;

Register, June, 1984, No. 342

ILHR 33

3. Site plan and profile map showing location of towers, power units, counterweights and pits;

4. Clearances of towers, system path and counterweights; and

5. Details of tower construction mountings, foundations and supports, sheave assemblies and carriages.

(c) The specifications shall be coordinated with the plans and describe the quality of the materials.

(d) All plans submitted for review shall be accompanied by sufficient data and information for the department to judge if the design of the system, the capacity of the equipment, and the performance of the system will meet the provisions of this chapter.

(2) **PLAN APPROVAL.** (a) If, upon review, the department determines that the plans and the specifications for the proposed system substantially conform to the provisions of this chapter, a conditional approval, in writing, shall be granted. All non-code-complying conditions stated in the conditional approval shall be corrected before or during construction or erection. A conditional approval issued by the department is not to be construed as an assumption of any responsibility for the design or construction of the system.

(b) If the department determines that the plans or the specifications for the proposed system do not substantially conform to the provisions of this chapter, the application for conditional approval shall be denied in writing.

(3) **EVIDENCE OF PLAN APPROVAL.** (a) At least one set of plans of the system bearing the department's stamp of conditional approval and a copy of the specifications for a new system shall be kept at the installation site. The plans shall be open to inspection by an authorized representative of the department.

(b) At least one set of approved plans of the new system shall be retained at the installation area for at least 3 years after the system's installation. The plans shall be open to inspection by an authorized representative of the department.

(4) **REVOCATION OF APPROVAL.** The department may revoke any approval, issued under the provisions of this chapter, for any false statements or misrepresentation of facts on which the approval was based.

History: Cr. Register, June, 1984, No. 342, eff. 7-1-84.

ILHR 33.04 Notification of alterations. No alteration of an aerial tramway, aerial lift, surface lift or rope tow which affects the design, structural strength or operation of a system or which replaces any piece of major equipment of a system may be initiated until written notification has been sent to the department indicating the proposed alterations or modifications to be undertaken.

History: Cr. Register, June, 1984, No. 342, eff. 7-1-84.

ILHR 33.05 Petition for variance. The department may consider and may grant a variance to an administrative rule upon receipt of a fee and a completed petition for variance form from the owner, provided an equivalency is established in the petition for variance which meets the Register, June, 1984, No. 342

intent of the rule being petitioned. The department may impose specific conditions in a petition for variance to promote the protection of the health, safety or welfare of the employes or the public. Violation of those conditions under which the petition is granted shall constitute a violation of this chapter.

Note #1: A copy of a petition for variance (form SB-3) is available from the Division of Safety and Buildings, P.O. Box 7969, Madison, Wisconsin 53707.

Note #2: Section 101.02 (6), Stats., outlines the procedure for submitting petitions to the department and the department procedures for hearing petitions.

History: Cr. Register, June, 1984, No. 342, eff. 7-1-84.

ILHR 33.06 Department inspections. (1) **NEW INSTALLATIONS.** Every new system and addition to or relocation of an existing system shall be inspected by an authorized representative of the department to ascertain whether or not the construction or installation conforms to the conditionally approved plans, the conditional approval letter and the provisions of this chapter.

(a) Notice shall be given to the department at least 10 days prior to the time the system is ready for inspection.

(b) The department shall complete its inspection within 14 days after the system is ready for inspection or may issue a temporary permit to operate until such an inspection is completed and installation is approved or disapproved.

(2) **PERIODIC INSPECTIONS.** All aerial tramways, aerial lifts, surface lifts and rope tows, including existing systems erected or constructed prior to the effective date of this chapter, shall be subject to inspection at least once every 12 months by an authorized representative of the department. The purpose of the department inspection shall be to ascertain whether or not the systems conform to the provisions of this chapter and, where applicable in the case of existing systems, to the appropriate provisions of ch. Ind 46 as it existed prior to the effective date of this chapter.

Note: Prior to the adoption of chapter ILHR 33, administrative rules for aerial tramways, aerial lifts, surface lifts and rope tows were specified in ch. Ind 46, Wis. Adm. Code.

(3) **LOAD TESTS.** (a) Prior to public use, a load test, to be witnessed by the department, shall be conducted for every new installation of, relocation of or addition to an aerial tramway or an aerial lift.

(b) A load test shall include:

1. Thorough operating tests under full loading and any partial loading that may provide the most adverse operating conditions;

2. Test loads per carrier of at least 110% of the design live load; for the purposes of design, passenger weight shall be considered to be at least 170 pounds;

3. Passing a loaded carrier with twice the design live load around the bull wheel at full speed where loaded carriers can pass around a terminal;

4. Checking the functioning of all push-button stops, automatic stops, limit switches, selected deropement switches and communication devices;

ILHR 33

5. Checking acceleration and deceleration rates under all loadings;

6. Proving the adequacy of all brakes and backstops under the most adverse loading; and

7. At least 6 hours of continuous operation with empty carriers to check for overheating of moving parts, excessive vibration or excessive deflection of mechanical or structural components and excessive free movement of the tensioning systems.

(4) **ADDITIONAL DATA.** When requested, additional data pertaining to the design, construction, materials or equipment of a system shall be submitted to the department for approval or to substantiate compliance with the provisions of this chapter.

History: Cr. Register, June, 1984, No. 342, eff. 7-1-84.

ILHR 33.07 Owner's responsibility. No owner may construct or alter any system or portion of a system, or permit any system to be constructed or altered except in compliance with the provisions of this chapter. Compliance with the provisions of this chapter does not relieve the owner from compliance with other rules.

History: Cr. Register, June, 1984, No. 342, eff. 7-1-84.

ILHR 33.08 Fees. Fees for plan examinations, inspections and certificates of operation shall be computed and submitted to the department as specified in ch. Ind 69.

Note: See appendix for further explanatory material.

History: Cr. Register, June, 1984, No. 342, eff. 7-1-84.

ILHR 33.09 Penalties. Penalties for violations of this chapter shall be assessed pursuant to s. 101.02 (12) and (13) (a), Stats.

Note #1: Section 101.02 (13) (a), Stats., indicates penalties will be assessed against any employer, employe, owner or other person who fails or refuses to perform any duty lawfully enjoined, within the time prescribed by the department, for which no penalty has been specifically provided, or who fails, neglects or refuses to comply with any lawful order made by the department, or any judgment or decree made by any court in connection with ss. 101.01 to 101.25. For each such violation, failure or refusal, such employer, employe, owner or other person must forfeit and pay into the state treasury a sum not less than \$10 nor more than \$100 for each such offense.

Note #2: Section 101.02 (12), Stats., indicates that every day during which any person, persons, corporation or any officer, agent or employe thereof, fails to observe and comply with an order of the department will constitute a separate and distinct violation of such order.

History: Cr. Register, June, 1984, No. 342, eff. 7-1-84.

SUBCHAPTER III GENERAL REQUIREMENTS

ILHR 33.10 Application. The requirements in this subchapter shall apply to all aerial tramways, aerial lifts, surface lifts and rope tows.

History: Cr. Register, June, 1984, No. 342, eff. 7-1-84.

ILHR 33.11 Design passenger weight. For the purpose of design, a passenger of a system shall be considered as having a weight of not less than 170 pounds.

History: Cr. Register, June, 1984, No. 342, eff. 7-1-84.

Register, June, 1984, No. 342

ILHR 33.12 Towers and structures. All towers and structures and their foundations shall be designed and constructed in accordance with the requirements specified in chs. Ind [ILHR] 50 to 64.

History: Cr. Register, June, 1984, No. 342, eff. 7-1-84.

ILHR 33.13 Power sources. (1) **ELECTRICAL.** (a) All electrical installations shall conform to the requirements specified in ch. ILHR 16.

(b) All electrical installations over 600 volts shall comply with the ch. PSC 114 in addition to the requirements specified in ch. ILHR 16.

(c) All transformer stations and other high voltage electrical equipment shall be marked with conspicuous warning signs. All power equipment shall be protected against overcurrent by circuit breakers or fuses.

(d) Signal, lighting, communication and control circuits may be supported between the towers that support a system. Voltage on overhead or exposed circuits shall be limited to 50 volts with the exception of intermittent ring-down circuits for telephone systems.

(e) All underground exterior lighting and snow-making circuits, mounted on or within 60 feet a system's centerline, shall be ground-fault-interrupter protected.

(f) All metallic structures shall be connected to a common grounding conductor. Electrical continuity of all metal parts of the structures shall be assured by mechanical connection.

(g) The drive terminal structure shall have one point referred to as a ground point. All direct-current and alternating-current electrical systems shall be referenced to the ground point.

1. If an electrical power unit is used, the electric service grounding electrode conductor shall terminate at this point.

2. Under the worst case conditions, the resistance from the ground point to any grounded point within the system shall not exceed 50 ohms.

3. To ensure that the 50-ohm grounding requirement is met under all conditions of soil, moisture, temperature, and circulating ground and air currents, all terminals and line structures shall be bonded together with a bonding conductor.

4. The grounding system for a tramway, lift or tow shall not be used as a grounding system for any other type of system not related to the tramway, lift, or tow system.

(h) Grounding sheaves or equivalent means shall be provided at one location for the purpose of grounding track cables and haul ropes, as applicable, for static electrical discharge.

(i) All systems equipped with electrical power units shall have phase loss protection on all power phases.

(2) **FLAMMABLE AND COMBUSTIBLE LIQUIDS.** All flammable and combustible liquids, such as, but not limited to, gasoline and diesel fuel, shall be stored, handled and used in accordance with the requirements specified in ch. Ind 8.

ILHR 33

(3) **LPG AND LNG.** Liquefied petroleum gases, LPG, and liquefied natural gases, LNG, shall be used, handled and stored in accordance with the requirements specified in ch. Ind 9.

(4) **STATIONARY COMBUSTION ENGINES.** Stationary combustion engines shall be installed and operated in accordance with NFPA 37-1979, Standard for the Installation and Use of Stationary Combustion Engines and Gas Turbines.

History: Cr. Register, June, 1984, No. 342, eff. 7-1-84.

ILHR 33.14 Machine guarding. Moving machine parts shall be guarded in accordance with the provisions specified in ch. Ind 1000-2000.

History: Cr. Register, June, 1984, No. 342, eff. 7-1-84.

ILHR 33.15 Wire ropes, cables and strands. (1) **GENERAL.** All wire ropes, cables and strands shall be designed, constructed and maintained in accordance with the provisions of ANSI B77.1, section 7.

(2) **WIRE ROPE TOWS.** No wire haul rope may be permitted to remain in service for a rope tow when broken wires are visible on the exterior portions of the strands.

History: Cr. Register, June, 1984, No. 342, eff. 7-1-84.

ILHR 33.16 Maintenance. (1) **GENERAL.** All aerial tramways, aerial lifts, surface lifts and rope tows shall be kept in good operating condition, properly lubricated and clean, including counterweight areas and pits and machine rooms and areas.

(2) **LOCK OUTS.** Provisions shall be incorporated, including the use of lock out devices, to render an aerial tramway, aerial lift, surface lift or rope tow inoperable when persons are working on the system.

(3) **RECORDS.** Permanent records shall be kept of all inspections and major repairs made to all systems. These records shall be made available to the department upon request.

History: Cr. Register, June, 1984, No. 342, eff. 7-1-84.

ILHR 33.17 Accidents and evacuation. (1) **ACCIDENTS.** (a) *First aid.* Provisions shall be made to render first aid to a person injured as a result of use or operation of a system.

(b) *Reporting.* An accident resulting in bodily injury as a result of a system malfunctioning shall be reported to the department within 10 days from the date of the accident.

Note: Accidents are to be reported to:

Bureau of Safety Inspection, Division of Safety and Buildings
Department of Industry, Labor and Human Relations
P.O. Box 7969
Madison, Wisconsin 53707

(2) **EVACUATION.** Provisions shall be made for the emergency evacuation of aerial tramways and aerial lifts.

(a) *Provisions.* Evacuation provisions shall include:

1. A written plan of evacuation;
2. Equipment and personnel necessary for evacuation; and

Register, June, 1984, No. 342

3. Adequate training of personnel in evacuation procedures.

(b) *Equipment.* 1. Evacuation equipment for aerial tramways and aerial lifts conveying passengers more than 250 feet above the ground or over obstacles such as, but not limited to, rivers, shall include an emergency carrier system or other approved rescue device.

2. All nonmetallic rope used for evacuation shall be of synthetic polyester fiber or of a hard lay nylon with a minimum diameter of 7/16 inch and a minimum breaking strength when new of at least 5000 pounds. No natural fiber or polypropylene ropes may be used for evacuation purposes.

3. All nonmetallic ropes used for evacuation shall be carefully stored when not in use, and shall be examined by the owner after each complete lift evacuation and prior to each season of operation, both summer and winter, to ascertain that they are in usable condition.

(c) *Drills.* 1. At least one evacuation drill to train personnel shall be conducted every 12 months.

2. A record of all evacuation drills shall be maintained by the owners of the systems and be made available to the department upon request.

History: Cr. Register, June, 1984, No. 342, eff. 7-1-84.

ILHR 33.18 Communications. Every aerial tramway, aerial lift, surface lift and rope tow requiring 2 or more attendants shall be provided with a permanently installed two-way communication system with communication stations at all loading areas, unloading areas and operating controls, and in carriers of aerial tramways where an attendant is required. The power for the communication equipment shall be independent of the primary power source for the system.

History: Cr. Register, June, 1984, No. 342, eff. 7-1-84.

SUBCHAPTER IV AERIAL TRAMWAYS

ILHR 33.20 Application. The requirements of this subchapter shall apply to all aerial tramways.

History: Cr. Register, June, 1984, No. 342, eff. 7-1-84.

ILHR 33.21 Design requirements. All aerial tramways shall be so designed and constructed that the maximum loads will not stress any part of a system beyond allowable limits.

(1) **POWER UNITS.** Except as provided in par. (b), every aerial tramway shall have at least 2 functional power units, a primary power unit and a secondary power unit.

(a) 1. The primary power unit shall have the capability of handling the system's most unfavorable design loading conditions, including the starting of a fully loaded aerial lift.

2. The secondary power unit shall have the capability to unload a fully loaded aerial lift in the event of the failure of the primary power unit.

(b) Each power unit shall:

1. Have an independent power source; and
2. Not depend upon the mechanical integrity of the other power unit to drive the aerial tramway.

(c) An aerial tramway with only one functional power unit may be operated:

1. For maintenance purposes; or
2. For unloading purposes.

(2) **BRAKES.** (a) *Service brake.* Every aerial tramway shall be provided with an automatic service brake to stop and hold the system under maximum load when the power is shut off or the system is stopped for any reason.

1. The service brake shall be applied to a drive shaft so that there is no clutch, or similar device, between the brake and the drive sheave.

2. The service brake shall be applied by springs or weights, except where another approved type of fail-safe brake is to be installed.

3. The service brake shall be normally in the applied position. It shall be held open for operation of the aerial tramway by a device which is automatically cut out when power is shut off or the system is stopped.

4. The service brake shall decelerate the aerial tramway at a minimum rate of one foot per second per second when operating under the most unfavorable condition of overhauling load and at full speed.

(b) *Overspeed brake.* Every aerial tramway shall be provided with an automatic overspeed brake or device which will interrupt the power to the power unit and actuate the service brake or an approved independent brake, when the speed of the system exceeds the rated speed by more than 10%.

(c) *Emergency brake.* Every aerial lift shall be provided with an emergency brake. The emergency brake shall have the capability to stop and hold the lift under the most unfavorable design loading condition.

1. The emergency brake shall act on the system's drive sheave assembly.

2. The controls to activate the emergency brake shall be located within 10 feet from an attendant. The controls shall not be located in a position that would require the attendant to pass through the path of moving carriers in order to operate the controls.

3. The emergency brake shall be automatically applied by springs, weights or other approved forms of stored energy.

4. The activation of the emergency brake shall automatically stop the system's power unit.

5. The emergency brake shall have the capability to stop an aerial tramway operating at full speed and under the most unfavorable condition of overhauling load at a deceleration rate not less than 1.5 feet per second per second.

6. The emergency brake shall stop an aerial tramway at a maximum deceleration rate of 7 feet per second per second.

(3) **SPEED REDUCERS AND GEARING.** (a) *General.* All speed reducers and gearing shall have the capacity for starting and operating an aerial tramway under the most unfavorable design loading conditions.

(b) *Manual transmissions.* Where manual transmissions are used, gears shall not be shifted when the aerial tramway is moving.

(c) *Reversing.* Where a system has reverse direction capabilities, provisions shall be made to prevent the accidental shifting into reverse whenever the aerial tramway is operating.

(d) *Standards.* Speed reducers and gearing shall comply with the applicable standards of the American Gear Manufacturers Association, AGMA, specified in subds. 1. to 6.

1. Surface Durability (Pitting) Formulas for Straight Bevel and Zerol Bevel Gear Teeth, AGMA 212.02.

2. Rating the Pitting Resistance and Bending Strength of Spur and Helical Involute Gear Teeth, AGMA 218.01.

3. Rating the Strength of Straight Bevel and Zerol Bevel Gear Teeth, AGMA 222.02.

4. Practice for Enclosed Speed Reducers or Increaseers Using Spur, Helical, Herringbone and Spiral Bevel Gears, AGMA 420.04.

5. Practice for Gearmotors Using Spur, Helical, Herringbone and Spiral Bevel Gears, AGMA 460.05.

6. Practice for Spur, Helical and Herringbone Gear Shaft-Mounted Speed Reducers, AGMA 480.06.

(4) **SHEAVES.** (a) *General.* 1. All sheaves, including the mountings and frames, shall be designed to withstand all static and dynamic loads.

2. Unlined sheaves for wire ropes shall have grooves with V-shaped cross-sections and shall have rounded bottoms with a radius equal to not less than 55% of the rope diameter.

3. For the purpose of this subsection, the diameter of a sheave shall be measured at the bottom of the sheave's groove.

(b) *Terminal and deflection sheaves.* 1. Frames for terminal and deflection sheaves shall be designed to retain the haul rope in the event of sheave, shaft or mounting failure.

2. a. The minimum diameter for terminal sheaves and deflection sheaves shall be at least 72 times the nominal diameter of the haul rope, provided that no gripping device passes around the sheave.

b. The minimum diameter for terminal sheaves and deflection sheaves shall be at least 96 times the nominal diameter of the haul rope where gripping devices pass around the sheave.

3. Terminal sheave assemblies and deflection sheave assemblies shall be designed to retain the haul rope in the event of a deropement from the sheave.

4. Terminal sheaves shall be designed so that the haul rope does not slip in the sheave groove.

(c) *Counterweight rope sheaves.* 1. Except as provided in subd. 2., the minimum diameter for counterweight sheaves shall be as specified in Table 33.21.

Table 33.21
Minimum Diameters for Counterweight
Rope Sheaves

Rope Classification	Sheave Diameter		
	Condition A ¹	Condition B ²	Condition C ³
6 x 7	72d	42d	24d
6 x 19	45d	30d	20d
6 x 37	27d	18d	12d

Note #1: Condition A is applicable where bending over sheaves is of major importance. This condition is to be used as a minimum design criterion for track cable counterweight ropes.

Note #2: Condition B is applicable where bending over sheaves is important, but some sacrifice in rope life is acceptable to achieve reduction in weight, economy in design or other purpose.

Note #3: Condition C is applicable to sheaves that are not intended to rotate due to any tension sheave movement but are intended to rotate only due to counterweight adjustment.

Note #4: "d" equals the nominal counterweight rope diameter.

2. Where a locked coil track cable passes over a sheave or roller chain and connects directly to a counterweight, the radius of curvature of the sheave or the roller chain shall not be less than 100 times the cable diameter or 1200 times the dimension of the cross-section of the largest wire of the cable, whichever is greater.

(d) *Haul rope sheaves and mounts.* Sheaves which support or hold down the haul rope at towers shall comply with the requirements of this paragraph.

1. The diameter of a haul rope sheave shall not be less than 10 times the nominal diameter of the haul rope for metallic sheaves or 8 times for sheaves with elastomer liners.

2. The design and construction of a haul rope sheave assembly shall be such that the haul rope cannot become entangled in the sheave assembly in the event the haul rope leaves the sheave away from a tower.

3. On hold-down sheave assemblies, rope-catching devices shall be installed to prevent the haul rope from moving upward in the event of deropement.

4. On support sheave assemblies, rope-catching devices shall be installed to prevent the haul rope from falling in the event of deropement. Rope-catching devices shall extend a minimum of 2 haul rope diameters beyond the sheave flange and shall be located less than one sheave diameter above or below the normal operating position of the rope.

5. Each haul rope sheave assembly shall be provided with devices which will stop an aerial tramway in case of haul rope deropement.

6. Sheave mounts or mounting frames shall be designed to be adjustable, allowing the sheave assemblies to be aligned and held in the plane of the haul rope.

7. Provisions shall be made to retain the haul rope in the sheave grooves under all loading conditions.

(5) TRACK CABLE SADDLES AND MOUNTS. (a) *Saddle radius*. The radius of a track cable saddle shall be not less than that which requires the largest radius to:

1. Minimize bending stresses in the cable; the radius shall be equal to at least 1200 times the largest dimension of the outer wire of the cable;

2. Provide smooth transition of the carrier trucks from span to span;

3. Reduce the bearing pressure to a value that will permit proper lubrication of the cable to facilitate sliding in the saddle groove; or

4. Prevent a carrier's truck wheels to lose contact under uplift centrifugal forces, if an aerial tramway's carrier trucks were to travel over the saddle at twice normal speed.

(b) *Saddle length*. The track cable saddle shall be of sufficient arc length to ensure that under maximum loading conditions the cable will not come into contact with the end of the saddle groove.

(c) *Saddle design*. 1. Track cable saddles shall be designed so that a track cable brake, if any, may function at the time a carrier is passing the saddle without derailment of the carrier's trucks.

2. Track cable saddles shall permit free passage of the carrier trucks even when the carrier is swinging laterally to its design limit as it approaches or passes a tower.

(6) COUNTERWEIGHT AND TENSIONING SYSTEMS. A counterweight or other approved devices shall be provided to determine and regulate the tension of the haul rope.

(a) *Design*. 1. A counterweight, where used, shall be arranged and maintained to move freely up and down.

2. Where a counterweight is contained in a structural frame, guides shall be provided to protect the frame, and to ensure free movement of the counterweight.

3. The counterweight, or other approved device, shall have sufficient travel to take care of all operating changes in loading and temperature.

(b) *Guarding of counterweights*. Guardrails or enclosures shall be provided to prevent persons from coming in contact with or passing under counterweights.

(c) *Winches*. 1. Winches which are used for a counterweight system's take-up and remain a permanent part of that system, shall have a minimum factor of safety of 6 relative to the ultimate capacity. Where this factor of safety cannot be established by manufacturer's endorsement, a safety device shall be installed on the counterweight rope ahead of the

winch that will keep the tensioning system intact in the event of failure or release of the winch.

2. Winches shall have a positive lock against release.

(7) HAUL ROPES. (a) *Factor of safety.* Haul ropes, when new, shall have a minimum static factor of safety of 5.

(b) *Splices.* 1. The splicing of a haul rope shall be prohibited except for systems where 2 haul ropes are employed. One haul rope may be spliced, if the other unspliced haul rope is capable of sustaining the maximum load of the system with a static factor of at least 5 if the other haul rope was broken.

2. The minimum length of a splice for a haul rope shall be 1200 times the nominal rope diameter.

3. The tails of the haul rope strands tucked into the core of the rope on splicing, shall be a minimum of 30 times the nominal rope diameter in length.

4. Where 2 or more splices occur in a haul rope, the splices shall be separated by an undisturbed length of rope which equals a minimum of 2400 times the nominal rope diameter.

(c) *End connections.* Sockets used as end connections for haul ropes on multicable aerial tramways shall be capable of developing the full strength of the rope to which the sockets are attached.

(d) *Lubrication.* Substances used to lubricate a haul rope shall be of a type which will not adversely affect a sheave or sheave liner.

(8) TRACK CABLE. (a) *Design.* 1. Wire rope, where used as track cables, shall have an independent wire rope or strand center.

2. Track cables consisting of one strand comprised entirely of round wires shall be prohibited.

(b) *Factor of safety.* Track cables, when new, shall have a minimum static factor of safety of 3 and a minimum dynamic factor of safety of 2.5.

(c) *Splices.* 1. Splices shall not be permitted in wire rope used as a track cable.

2. Couplings shall not be permitted in track cables.

(d) *End connections.* Rope and cable sockets shall be designed so that they are not stressed beyond the yield point of the material used when the ropes or cables anchored are under tensions equal to their nominal breaking strength.

(e) *Lubrication.* Substances used to lubricate a track cable shall be of a type which will not adversely affect a sheave or sheave liner.

(9) COUNTERWEIGHT ROPES. (a) *Factor of safety.* Counterweight ropes, when new shall have a minimum factor of safety of 6. The factor of safety shall be equal to the nominal breaking strength of the rope divided by the maximum static design tension.

(b) *Adjustment.* Counterweight ropes shall be adjusted so that the counterweight will reach the end of its travel before the attached tension sheave carriage comes within 6 inches of the end of its travel.

(c) *Splices.* Splices in counterweight ropes shall be prohibited.

(d) *End connections.* 1. End connections of counterweight ropes shall not fail or slip under a tension equal to 80% of the strength of the rope.

2. Sections of counterweight rope permanently deformed or damaged by the application of wire rope clips, or bent around thimbles, sheaves, or other anchoring devices not meeting the minimum diameters specified in ANSI B77.1, section 7 shall not be relocated or reused as a part of the section under load.

(e) *Metallic core.* Counterweight ropes shall have metallic cores.

(10) **TRACK CABLE TRUCK WHEELS.** (a) *Loading.* 1. The weight of a loaded carrier shall be distributed over all truck wheels so that the load per wheel does not exceed that permitted by the wheel liner material.

2. Where a track strand is used with unlined sheaves, the load per wheel shall not exceed 1/80 of the minimum design tension in the track cable.

3. Where a track strand is used with sheaves with resilient liner material, the load per wheel shall not exceed 1/60 of the minimum design tension in the track cable.

4. Where wire rope is used as a track cable, the load per wheel shall not exceed 1/40 of the minimum design tension in the track cable.

(b) *Design.* The truck wheels shall be designed to prevent them from leaving the track cable.

(11) **CARRIERS.** Carriers for aerial tramways shall comply with the requirements specified in pars. (a) to (d).

(a) *Cabins.* 1. Passenger cabins shall be enclosed and ventilated.

2. Cabins shall be equipped with doors which fill the entire entrance opening.

a. Each door shall be provided with a lock located in such a manner that it cannot be unlocked except by authorized persons.

b. A key for the door lock shall be placed under glass with a notice posted to prohibit use except under specified emergency conditions.

3. All cabin windows shall be of shatterproof material.

4. Cabin floor space available to passengers may not be less than 2.5 square feet per person for the first 15 passengers and 2.0 square feet per passenger thereafter.

5. Each cabin having a capacity of more than 6 passengers, shall be provided with emergency evacuation equipment which is located in the cabin.

6. An attendant shall be present in each cabin having a capacity of more than 6 passengers and shall have controls to stop the aerial tramway.

Note: See s. ILHR 36.26 (2) regarding provisions for manual stop switches.

7. Each cabin shall be provided with a first aid kit.
8. Each cabin shall be provided with the appropriate signs indicating:
 - a. The maximum capacity, in pounds and number of passengers;
 - b. The exits;
 - c. Caution when exiting;
 - d. No smoking; and
 - e. Ski tips up and pole tips down.

(b) *Hangers.* 1. The hanger for a carrier shall be of sufficient length vertically so that under longitudinal swing the top of the carrier cannot strike the haul rope, the track cables or the bottom of a tower saddle.

2. The carrier shall be able to swing longitudinally, without interference, to an angle of 15° from the vertical.

(c) *Sway dampers.* Sway dampers, where used, shall operate smoothly and without danger of deropement of the track cable trucks or the haul rope.

(d) *Track cable brakes.* Each carrier of a multicable aerial tramway shall be equipped with a brake which will grip the track cable.

1. The brake shall be capable of stopping and holding a fully loaded carrier at the point of maximum gradient of the track cables.

2. The brake shall function automatically in case of a haul rope failure.

3. Application of the track cable brake shall automatically disconnect or stop the system's power unit.

History: Cr. Register, June, 1984, No. 342, eff. 7-1-84.

ILHR 33.22 System location and clearances. (1) **CARRIER CLEARANCE.** Trees or vegetation shall not extend within 5 feet of any portion of an aerial tramway's carrier.

(2) **VERTICAL CLEARANCES.** Except at loading and unloading areas, a minimum vertical clearance of 5 feet shall be maintained between the lowest edge of an aerial tramway's carrier, the carrier's haul ropes and track cables and the terrain and other obstacles, including snow pack.

(a) Wherever the vertical clearance is less than 15 feet, no surface transportation shall be permitted beneath an aerial tramway.

(b) Wherever the vertical clearance is less than 8 feet, provisions shall be made to prevent access to the area beneath the system by unauthorized persons.

(3) **HORIZONTAL CLEARANCES.** (a) The horizontal distance between 2 passing aerial tramway carriers, each swung 10° inward from the vertical shall be not less than 2 feet 6 inches or the distance D, whichever is greater, where:

Register, June, 1984, No. 342

$$D = 0.02(X) \left[1 - \frac{X}{S} \right]$$

where:

S is the slope length of the span, in feet; and

X is the slope distance, in feet, from the point of the carriers passing to the nearest tower or track rope supporting structure

(b) The distance between haul ropes or track cables, for the purpose of determining this horizontal clearance, shall be considered as equal to the gauge of the line.

(4) LOCATION. (a) Unless approved by the department, an aerial tramway shall not be located under:

1. Trees or branches;
2. Terrain features, including cliffs and overhangs;
3. Bridges; and
4. Buildings and structures other than at loading and unloading areas.

(b) 1. Unless approved by the department, an aerial tramway shall not be located under or over electrical lines greater than 50 volts.

2. Aerial tramway systems and electrical power lines of greater than 50 volts shall be separated by a distance such that:

- a. Passengers cannot come in contact with the electrical lines; or
- b. If the electrical lines break or collapse, the lines will not come in contact with any part of the tramway system.

History: Cr. Register, June, 1984, No. 342, eff. 7-1-84.

ILHR 33.23 Loading and unloading areas. (1) PLATFORMS. Loading and unloading platforms serving aerial tramways shall be sized to accommodate passengers embarking onto and disembarking from the carriers.

(2) SEGREGATION OF PASSENGERS. Provisions shall be made for separation of passengers embarking onto and disembarking from the aerial tramway's carriers.

(3) RAILINGS. Railings shall be provided to guide passengers safely to and from the carriers of an aerial tramway.

(4) CARRIER GUIDE RAILS. Guide rails with curved ends shall be provided so that entrance and exit of an aerial tramway's carriers to and from the loading and unloading platforms can be accomplished smoothly and with minimum impact when carriers are deflected from the vertical 10° laterally and, simultaneously, 10° longitudinally.

History: Cr. Register, June, 1984, No. 342, eff. 7-1-84.

ILHR 33.24 Towers. (1) TOWER IDENTIFICATION. All towers for an aerial tramway shall be identified with successive numbers.

(2) TOWER GUYS. Where the tower guys of an aerial tramway intersect the ground within or near ski runs, the guys shall be marked for visibility with boards with painted black and yellow stripes or other approved

Register, June, 1984, No. 342

means. Painted boards shall be at least 8 inches in nominal width and shall extend at least 8 feet in length above the surface of the snow.

History: Cr. Register, June, 1984, No. 342, eff. 7-1-84.

ILHR 33.25 Carrier speeds. Except as provided in subs. (1) and (2), carriers for aerial tramways shall not exceed the speed limits specified in Table 33.25.

**Table 33.25
Maximum Carrier Speeds
(in feet per minute)**

Condition	Monocable System	Multicable System
Clear spans	2000	2000
Across towers	1000	1500
Entering loading and unloading areas	300	300

(1) **MULTICABLE SYSTEMS.** Where on a multicable aerial tramway a carrier's truck wheels come in contact with or ride on any part of the track cable saddle, the carrier's speed over the saddle shall not exceed 800 feet per minute.

(2) **CARRIERS WITHOUT ATTENDANTS.** Where there is no attendant in a carrier, the maximum allowable speeds specified in Table 33.25 shall be reduced by 25% for clear spans and 30% across towers.

History: Cr. Register, June, 1984, No. 342, eff. 7-1-84.

ILHR 33.26 Manual and automatic stop switches. (1) **GENERAL.** (a) All electric control circuits for stop switches shall be energized circuits so that in the event of an electric power failure, the aerial tramway shall be inoperative.

(b) An inadvertent ground shall cause an automatic stop switch to be activated.

(c) Where guillotine-type stop switches are used to sever wires in the emergency stop circuit upon haul rope deropement from a sheave, solid-wire conductors shall be used.

(d) All stop switches, manual and automatic, shall be of a type which must be reset manually.

(e) When there is only one stop circuit, it shall be classified as the emergency stop circuit.

(f) Interruption of the emergency stop circuit shall stop the power unit of the aerial tramway in use at the time.

(2) **MANUAL STOPS.** (a) All aerial tramways shall be provided with manual stop switches which will stop the system's power unit and activate the service brake.

(b) Manual stop switches shall be installed at the following locations:

Register, June, 1984, No. 342

1. At each loading and unloading area;
2. In carriers required to have an attendant; and
3. At the aerial tramway's operating controls.

(3) **AUTOMATIC STOPS.** (a) All aerial tramway systems shall be provided with automatic stop switches which will stop the system's power unit and activate the service brake.

(b) An automatic stop shall be activated:

1. When manual or automatic controls fail to reduce a carrier's speeds to design values at critical points along the line;
2. Before a carrier reaches its limit of travel;
3. Before a counterweight or tension sheave carriage reaches its limit of travel; or
4. When a carrier's track cable brake is applied.

History: Cr. Register, June, 1984, No. 342, eff. 7-1-84.

ILHR 33.27 System operations. (1) **PERSONNEL.** Each aerial tramway shall have at least one attendant present at each loading area and unloading area.

(a) The duties of the attendants at the loading and unloading areas shall include observing for any potentially dangerous operational or mechanical developments within their view.

(b) Each required attendant shall have controls to stop the aerial tramway readily available and shall maintain an operating position not more than 10 feet from these controls.

(c) An aerial tramway shall be stopped whenever a required attendant is further than 10 feet from the controls to stop the system.

(2) **OPERATIONAL REQUIREMENTS.** After any stop, an aerial tramway shall not be started until the cause of the stop has been determined and clearance has been obtained from all of the system's attendants.

History: Cr. Register, June, 1984, No. 342, eff. 7-1-84.

SUBCHAPTER V AERIAL LIFT SYSTEMS

ILHR 33.40 Application. The requirements of this subchapter shall apply to all aerial lifts.

History: Cr. Register, June, 1984, No. 342, eff. 7-1-84.

ILHR 33.41 Design requirements. All aerial lifts shall be so designed and constructed that the maximum loads will not stress any part of a system beyond allowable limits.

(1) **POWER UNITS.** Except as provided in pars. (b) and (c), every aerial lift shall have at least 2 functional power units, a primary power unit and a secondary power unit. If the primary power unit becomes nonfunctional, the procedure to start up the secondary power unit shall be implemented within 15 minutes.

Register, June, 1984, No. 342

(a) 1. The primary power unit shall have the capability of handling the system's most unfavorable design loading conditions, including the starting of a fully loaded aerial lift.

2. The secondary power unit shall have the capability to unload a fully loaded aerial lift in the event of the failure of the primary power unit.

(b) Each power unit shall:

1. Have an independent power source; and

2. Not depend upon the mechanical integrity of another power unit to drive the aerial lift.

(b) A gondola lift with only one functional power unit may be operated:

1. For maintenance purposes; or

2. For unloading purposes.

(c) A chairlift with only one functional power unit may be operated:

1. For maintenance purposes;

2. For unloading purposes; or

3. For a period of not more than 10 days if:

a. All automatic brakes, manual brakes and the backstop brake are functional with the power unit;

b. All control circuits, safety gates and stop switches are functional and control the power unit;

c. Temperature and weather conditions are such that a 2-hour waiting period in the carrier would not be injurious to passengers; and

d. Evacuation gear and personnel are immediately available so that the entire lift can be evacuated in a 2-hour period.

(d) Where a power unit has reverse direction capabilities, provisions shall be made to prevent the accidental shifting into reverse whenever the aerial lift is operating.

(2) BRAKES. (a) *Service brake.* Every aerial lift shall be provided with an automatic service brake to stop and hold the system under maximum load when power is shut off or the system is stopped for any reason.

1. The service brake shall be applied to the drive shaft so that there is no clutch, or similar device, between the brake and the drive sheave.

2. The service brake shall be applied by springs or weights except where another approved type of fail-safe brake is to be installed.

3. The service brake shall be normally in the applied position. It shall be held open for operation of the aerial lift system by a device which is automatically cut out when power is shut off or the system is stopped.

4. The service brake shall be adjusted so that it is capable of stopping a system which is operating at full speed and under the most unfavorable loading conditions, in a distance not exceeding the larger of:

a. 10 feet; or

b. A distance in feet equal to $V^2/8,000$, where V is the aerial lift operating speed in feet per minute.

5. The rate of application of the service brake shall not cause an excessively rapid stop so as to cause undue swinging of the carriers or oscillations of the haul rope.

6. The controls for the service brake shall be located in a position that would not require an attendant to pass through the path of a moving carrier in order to operate the controls.

(b) *Emergency brake.* Every aerial lift shall be provided with an emergency brake. The emergency brake shall have the capability to stop and hold the lift under the most unfavorable design loading condition.

1. The emergency brake shall act on the system's drive sheave assembly.

2. The controls to activate the emergency brake shall be located within 15 feet from an attendant. The controls shall not be located in a position that would require the attendant to pass through the path of moving carriers in order to operate the controls.

3. The emergency brake shall be automatically applied by springs, weights or other approved forms of stored energy.

4. The activation of the emergency brake shall automatically stop the system's power unit.

5. The emergency brake shall be adjusted so that it is capable of stopping a system which is operating at full speed and under the most unfavorable loading conditions, in a distance not exceeding the greater of:

a. 10 feet; or

b. A distance in feet equal to $V^2/8,000$, where V is the aerial lift operating speed in feet per minute.

6. The emergency brake shall automatically activate when the speed of the haul rope exceeds the design value by 15% in the forward direction on an overhauling lift, or a reverse rotation exceeding that which normally activates the backstop brake.

(c) *Backstop brake.* Every aerial lift shall be provided with a backstop brake to automatically prevent reverse rotation of the system. The backstop brake shall act directly on a bull wheel, on a ring gear attached to the drive sheave or on the haul rope.

(d) *General.* The service brake, emergency brake and backstop brake shall be independent systems. The failure of one brake system shall not impair the functioning of the other brake systems.

(3) **SPEED REDUCERS AND GEARING.** (a) *General.* All speed reducers and gearing shall have capacity for starting and operating an aerial lift under the most unfavorable design loading conditions.

(b) *Manual transmissions.* Where manual multi-speed transmissions are used, gears shall not be shifted when the carriers of an aerial lift are moving.

(c) *Standards.* Speed reducers and gearing shall comply with the standards specified in s. ILHR 33.21 (3).

(4) **SHEAVES.** (a) *General.* 1. All sheaves, including the mountings and frames, shall be designed to withstand all static and dynamic loads.

2. Unlined sheaves for wire ropes shall have grooves with V-shaped cross-sections and shall have rounded bottoms with a radius not less than 55% of the rope diameter.

3. For the purpose of this subsection, the diameter of a sheave shall be measured at the bottom of the sheave's groove.

(b) *Terminal and deflection sheaves.* 1. Frames for terminal and deflection sheaves shall be designed to retain the haul rope in the event of sheave, shaft or mounting failure.

2. a. The minimum diameter for terminal sheaves and deflection sheaves shall be at least 72 times the nominal diameter of the haul rope, provided that no gripping device passes around the sheave.

b. The minimum diameter for terminal sheaves and deflection sheaves shall be at least 96 times the nominal diameter of the haul rope where gripping devices pass around the sheave.

3. Terminal sheave assemblies and deflection sheave assemblies shall be designed to retain the haul rope in the event of a deropement from the sheave.

4. Terminal sheaves and deflection sheaves shall be designed so that the haul rope does not slip in the sheave groove.

(c) *Counterweight rope sheaves.* 1. The minimum diameter for counterweight sheaves shall be as specified in Table 33.41, except as provided in subd. 2.

Table 33.41
Minimum Diameters for Counterweight
Rope Sheaves

Rope Classification	Sheave Diameter		
	Condition A ¹	Condition B ²	Condition C ³
6 x 7	72d	42d	24d
6 x 19	45d	30d	20d
6 x 37	27d	18d	12d

Note #1: Condition A is applicable where bending over sheaves is of major importance. This condition is to be used as a minimum design criterion for track cable counterweight ropes.

Note #2: Condition B is applicable where bending over sheaves is important, but some sacrifice in rope life is acceptable to achieve reduction in weight, economy in design or other purpose.

Note #3: Condition C is applicable to sheaves that are not intended to rotate due to any tension sheave movement but are intended to rotate only due to counterweight adjustment.

Note #4: "d" equals the nominal counterweight rope diameter.

2. Where a locked coil track cable passes over a sheave or roller chain and connects directly to a counterweight, the radius of curvature of the sheave or the roller chain shall not be less than 100 times the cable diameter or 1200 times the dimension of the cross-section of the largest wire of the cable, whichever is greater.

(d) *Haul rope sheaves and mounts.* Sheaves which support or hold down the haul rope at towers shall comply with the requirements of this paragraph.

1. The diameter of a haul rope sheave shall not be less than 10 times the nominal diameter of the haul rope for metallic sheaves or 8 times for sheaves with elastomer liners.

2. The design and construction of a haul rope sheave assembly shall be such that the haul rope cannot become entangled in the sheave assembly in the event the haul rope leaves the sheave away from a tower.

3. On hold-down sheave assemblies, rope-catching devices shall be installed to prevent the haul rope from moving upward in the event of deropement.

4. On support sheave assemblies, rope-catching devices shall be installed to prevent the haul rope from falling in the event of deropement. Rope-catching devices shall extend a minimum of 2 haul rope diameters beyond the sheave flange and be located less than one sheave diameter above or below the normal operating position of the rope.

5. On both hold-down and support sheaves, approved devices shall be installed and maintained which will stop an aerial lift in case of haul rope deropement.

6. Sheave mounts or mounting frames shall be designed to be adjustable, allowing the sheave units to be aligned and held in the plane of the haul rope.

7. Provisions shall be made to retain the haul rope in the sheave grooves under all loading conditions.

(5) **TRACK CABLE SADDLES AND MOUNTS.** (a) *Saddle radius.* The radius of a track cable saddle shall be not less than that which requires the largest radius to:

1. Minimize bending stresses in the cable; the radius shall be equal to at least 1200 times the largest dimension of the outer wire of the cable;

2. Provide smooth transition of the carrier trucks from span to span;

3. Reduce the bearing pressure to a value that will permit proper lubrication of the cable to facilitate sliding in the saddle groove; or

4. Prevent a carrier's truck wheels to lose contact under uplift centrifugal forces, if an aerial lift's carrier trucks were to travel over the saddle at twice normal speed.

(b) *Saddle length.* The track cable saddle shall be of sufficient arc length to ensure that under maximum loading conditions the cable will not come into contact with the end of the saddle groove.

(c) *Saddle design.* 1. Track cable saddles shall be designed so that a track cable brake, if any, may function at the time the carrier is passing the saddle without derailment of the carrier's trucks.

2. Track cable saddles shall permit free passage of the carrier trucks even when the carrier is swinging laterally to its design limit as it approaches or passes a tower.

(6) COUNTERWEIGHT AND TENSIONING SYSTEMS. A counterweight or other approved devices shall be provided to determine and regulate the tension of the haul rope.

(a) *Design.* 1. A counterweight, where used, shall be arranged to move freely up and down.

2. Where a counterweight is contained in a structural frame, guides shall be provided to protect the frame, and to ensure free movement of the counterweight.

3. The counterweight, or other approved device, shall have sufficient travel to take care of all operating changes in loading and temperature.

(b) *Guarding of counterweights.* Guardrails or enclosures shall be provided to prevent persons from coming in contact with or passing under counterweights.

(c) *Winches.* 1. Winches which are used for a counterweight system's take-up and remain a permanent part of that system, shall have a minimum factor of safety of 6 relative to the ultimate capacity. Where this factor of safety cannot be established by manufacturer's endorsement, a safety device shall be installed on the counterweight rope ahead of the winch that will keep the tensioning system intact in the event of failure or release of the winch.

2. Winches shall have a positive lock against release.

(7) HAUL ROPES. (a) *Factor of safety.* Haul ropes, when new, shall have a minimum static factor of safety of 5.

(b) *Splices.* 1. The minimum length of a splice for a haul rope shall be 1200 times the nominal rope diameter.

2. The tails of the haul rope strands tucked into the core of the rope on splicing, shall be a minimum of 30 times the nominal rope diameter in length.

3. Where 2 or more splices occur in a haul rope, the splices shall be separated by an undisturbed length of rope which equals a minimum of 2400 times the nominal rope diameter.

(c) *End connections.* Sockets used as end connections for haul ropes on multicable aerial lifts shall be capable of developing the full strength of the rope to which the sockets are attached.

(d) *Lubrication.* Substances used to lubricate a haul rope shall be of a type which will not adversely affect a sheave or sheave liner.

(8) TRACK CABLE. (a) *Design.* 1. Wire rope where used as track cables, shall have an independent wire rope or strand center.

2. Track cables consisting of one strand comprised entirely of round wires shall be prohibited.

(b) *Factor of safety.* Track cables, when new, shall have a minimum static factor of safety of 3 and a minimum dynamic factor of safety of 2.5.

(c) *Splices.* 1. Splices shall not be permitted in wire rope used as a track cable.

2. Couplings shall not be permitted in track cables.

(d) *End connections.* Rope and cable sockets shall be designed so that they are not stressed beyond the yield point of the material used when the ropes or cables they anchor are under tensions equal to their nominal breaking strength.

(e) *Lubrication.* Substances used to lubricate a track cable shall be of a type which will not adversely affect a sheave or sheave liner.

(9) COUNTERWEIGHT ROPES. (a) *Factor of safety.* Counterweight ropes, when new, shall have a minimum factor of safety of 6. The factor of safety shall be equal to the nominal breaking strength of the rope divided by the maximum static design tension.

(b) *Adjustment.* Counterweight ropes shall be adjusted so that the counterweight will reach the end of its travel before the attached tension sheave carriage comes within 6 inches of the end of its travel.

(c) *Splices.* Splices in counterweight ropes shall be prohibited.

(d) *End connections.* 1. End connections of counterweight ropes shall not fail or slip under a tension equal to 80% of the strength of the rope.

2. Sections of counterweight rope permanently deformed or damaged by the application of wire rope clips, or bent around thimbles, sheaves, or other anchoring devices not meeting the minimum diameters specified in ANSI B77.1, section 7, shall not be relocated or reused as a part of the section under load.

(e) *Metallic core.* Counterweight ropes shall have metallic cores.

(10) HAUL ROPE GRIPS. (a) *Design.* 1. Haul rope grips shall be designed to pass smoothly over and under sheaves which have flanges of adequate depth to prevent the haul rope from leaving the sheaves.

2. The design of a haul rope grip shall incorporate provisions to accommodate a 10% reduction in haul rope diameter.

(b) *Slippage.* 1. A haul rope grip shall be designed and maintained during use so as to resist a force, which tends to slide it along the haul rope, which is a minimum of 3 times the force required to move a carrier along a properly lubricated haul rope at the steepest incline, under the most adverse conditions of carrier loading.

2. A haul rope grip shall automatically adjust to maintain its gripping force with a 3% reduction in haul rope diameter.

3. A haul rope grip shall not be located closer than 3 feet to the tail of a haul rope or to the rope tuck of a splice.

(c) *Strength.* The strength of a haul rope grip shall be based upon the criteria specified in subds. 1. to 5.

1. All parts of a haul rope grip subject to a static stress which is proportional to the dead load and live load of a carrier shall have a minimum factor of safety such that, with the grip in its operating position, a downward load equal to the dead load of the carrier plus 6 times the design live load, will not cause any part of the grip to fail.

2. Those parts of a grip whose stress is not changed by the application of a live load shall be designed on the basis of an allowable stress of not more than the yield point divided by 3.0. In the design of springs, where used, the allowable stress may be increased if load tests are conducted by an approved testing laboratory to provide assurances that the fatigue life of the actual spring is more than ample for the various applied loads.

3. Grips subject to stresses caused by horizontal loads, such as centrifugal loads that stress the grips as they pass around the drive sheaves or return sheaves, shall be designed in accordance with sub. (12) (b) 2.

4. The material of which the grip is made shall be selected or selected and treated to obtain optimum impact resistance.

5. Grips made up of cast parts shall be proof-loaded with forces equal to the gripping force plus 3 times the sum of the dead load plus the design live load.

(d) *Maximum loads.* 1. The maximum total vertical load on a single haul rope grip may not exceed 1/14 of the minimum tension in the haul rope.

2. Where 2 or more haul rope grips are used for a single carrier, the maximum total vertical load on each grip shall not exceed 1/14 of the minimum tension in the haul rope, provided:

a. Each grip is independently loaded; and

b. The clear length of haul rope between the grips equals or exceeds one-half rope lay.

(e) *Detachable grips.* A detachable haul rope grip shall be designed and constructed in such a manner that it grips the haul rope positively without damaging the haul rope and in such a manner that it cannot become accidentally uncoupled.

(f) *Incorrect attachment.* Approved devices shall be installed which will stop an aerial lift, if any detachable grip is incorrectly attached to haul rope.

(11) **TRACK CABLE TRUCK WHEELS.** (a) *Loading.* 1. The weight of a loaded carrier shall be distributed over all truck wheels so that the load per wheel does not exceed that permitted by the wheel liner material.

2. Where a track strand is used with unlined sheaves, the load per wheel shall not exceed 1/80 of the minimum design tension in the track cable.

3. Where a track strand is used with sheaves with resilient liner material, the load per wheel shall not exceed 1/60 of the minimum design tension in the track cable.

4. Where wire rope is used as a track cable, the load per wheel shall not exceed 1/40 of the minimum design tension in the track cable.

(b) *Design.* The truck wheels shall be designed to prevent them from leaving the track cable.

(12) CARRIERS. (a) *Gondola systems.* Carriers for gondola systems shall comply with the requirements of this paragraph.

1. Passenger cabins of gondola systems shall be enclosed and ventilated.

2. Cabins shall be equipped with doors that fill the entire entrance opening.

a. Each door shall be provided with a lock located in such a manner that it cannot be unlocked except by authorized persons.

b. A key for the door lock shall be placed under glass with a notice posted to prohibit use except under specified emergency conditions.

3. All cabin windows shall be of shatterproof material.

4. Where passengers are to remain standing, floor space of at least 2.5 square feet per person shall be provided.

5. The width of cabin seats shall be at least 18 inches.

6. The maximum capacity of the cabin, both in pounds and number of passengers, shall be posted in the cabin.

7. Each cabin having a capacity of more than 6 passengers, shall be provided with emergency evacuation equipment which is located in the cabin.

8. An attendant shall be present in each cabin having a capacity of more than 6 passengers.

9. The hanger for a carrier shall be of sufficient length vertically so that under longitudinal swing the top of the carrier cannot strike the haul rope, the track cables, or the bottom of a tower saddle.

10. The carrier shall be able to swing longitudinally, without interference, to an angle of 15° from the vertical.

11. Sway dampers, where used, shall operate smoothly and without danger of deropement of the track cable trucks or the haul rope.

12. All carriers shall be clearly identified with successive numbers.

(b) *Chairlift systems.* Carriers for chairlift systems shall comply with the requirements of this paragraph.

1. Carriers of chairlifts systems shall be designed to support a vertical load 4 times the design load without permanent deformations of the assembly or component parts.

2. The parts of carriers, including the hangers and the grips, subject to dynamic stresses caused by horizontal loads, such as centrifugal loads that stress the carriers as they pass around terminal sheaves shall have:

a. A minimum factor of safety of 3.6 with respect to the yield point of the material when automatic stops are provided to prevent the passage of loaded carriers around a terminal sheave; or

b. A minimum factor of safety of 2.0 with respect to the yield point of the material when automatic stops are not provided to prevent the passage of loaded carriers around a terminal sheave.

3. All carriers shall be clearly identified with successive numbers.

4. Each carrier shall be equipped with a rail at each side. The rail shall be positioned at a height of not less than 4 inches above the seat and shall extend for a length of not less than 12 inches from the back of the seat to the front.

History: Cr. Register, June, 1984, No. 342, eff. 7-1-84.

ILHR 33.42 System location and clearances. (1) **SYSTEM'S PATH.** (a) Trees or vegetation shall not extend within 5 feet of any portion of a aerial lift's carrier.

(b) Trees located below the path of an aerial lift's carriers may not exceed a height of 6 feet for a width of 5 feet on each side of the centerline of the carriers' path of travel.

(2) **VERTICAL CLEARANCES.** (a) Except at loading areas and unloading areas, a minimum vertical clearance of 5 feet shall exist between the lowest edge of an aerial lift's carrier, a carrier's haul ropes and track cables and the terrain or other obstacles, including snow pack.

(b) Where skiing is permitted beneath an aerial lift system, a minimum vertical clearance of 13 feet shall be maintained between the snow surface and the top of the carrier's seat.

(c) No surface transportation may be permitted beneath an aerial lift system wherever the vertical clearance from the surface to the lowest part of a carrier is less than 15 feet.

(d) Provisions shall be made to prevent unauthorized persons access beneath aerial lift system wherever the vertical clearance is less than:

1. Eight feet from the lowest part of a gondola's carrier to the snow surface or the terrain; and

2. Eight feet from the top of the seat of empty carriers of a chair lift system to the snow surface or the terrain; and

3. Ten feet from the top of the seat of occupied carriers of a chair lift system to the snow surface or the terrain.

(3) **HORIZONTAL CLEARANCES.** (a) *Chair lift systems.* The minimum distance between 2 passing carriers of a chair lift system, each swung 10° inward from the vertical shall be not less than 2 feet 6 inches.

(b) *Gondola systems.* The horizontal distance between 2 passing carriers of a gondola system, each swung 10° inward from the vertical, shall be not less than 2 feet 6 inches or the distance D, whichever is greater, where:

$$D = 1/2\% \text{ span length between support towers.}$$

(4) **LOCATION.** (a) Unless approved by the department, an aerial lift shall not be located under:

1. Trees or branches;

Register, June, 1984, No. 342

2. Terrain features, including cliffs and overhangs;
3. Bridges; and
4. Buildings and structures, other than at loading and unloading areas.

(b) 1. Unless approved by the department, an aerial lift shall not be located under or over electrical lines greater than 50 volts.

2. Aerial lift systems and electrical lines of greater than 50 volts shall be separated by a distance such that:

- a. Passengers cannot come in contact with the electrical lines; or
- b. If the electrical lines break or collapse, the lines will not come into contact with any part of the lift system.

History: Cr. Register, June, 1984, No. 342, eff. 7-1-84.

ILHR 33.43 Loading and unloading areas. (1) **LOADING AREAS.** (a) Loading areas for aerial lifts shall be of sufficient length to permit passengers to load onto the carriers. The loading area for a chair lift shall be at least 8 feet in length, centered on the designated loading spot for the carriers.

(b) Towers adjacent to chair lift loading areas shall be protected to prevent ski tips of passengers from becoming entangled in the towers.

(c) Every loading area for aerial lifts shall have a definite method for marshalling passengers to the carriers.

(2) **UNLOADING AREAS.** Unloading areas for aerial lifts shall be of sufficient length to permit a passenger to unload from the carrier.

(a) *Gondola lifts.* Unloading areas for gondola lifts shall comply with the requirements specified in s. ILHR 33.23.

(b) *Chairlifts.* Unloading areas for chairlifts shall comply with the provisions of this paragraph. In this paragraph, the unloading area shall be comprised of the approach ramp; disembarking area; discharge ramp; and runout area.

1. The disembarking area shall be level and shall be at least 6 feet in length and at least 2 feet wider than the width of the carrier.

2. The disembarking area shall be preceded by an approach ramp with an ascending slope not to exceed a ratio of one to one. The lower edge of the approach ramp shall not be less than 6 feet below the top of the carrier seat. The approach ramp shall be at least as wide as the disembarking area.

3. The discharge ramp from the disembarking area shall be at least as wide as the disembarking area. The lower end of the discharge ramp shall be at least 4 feet below the elevation of the disembarking area.

4. The maximum slope of the discharge ramp from the disembarking area shall be 40%.

5. The minimum slope of the discharge ramp from the disembarking area shall be:

ILHR 33

a. 15% for chairlifts with a maximum carrier speed of 350 feet per minute;

b. 20% for chairlifts with a maximum carrier speed of 450 feet per minute; or

c. 25% for chairlifts with a maximum carrier speed greater than 450 feet per minute.

6. Where unloading occurs under a bullwheel, the beginning of the discharge ramp shall be located before the centerline of the bullwheel. The minimum horizontal distance between the discharge ramp and the centerline of the bullwheel shall be:

a. 6 feet for chairlifts with a maximum carrier speed of 350 feet per minute;

b. 8 feet for chairlifts with a maximum carrier speed of 450 feet per minute; or

c. 10 feet for chairlifts with a maximum carrier speed greater than 450 feet per minute.

7. The runout area beyond the discharge ramp shall be at least 20 feet in length. The maximum downward slope of the runout area shall be 5%.

Note: See Appendix for further explanatory material.

(3) INTERMEDIATE LOADING AND UNLOADING AREAS. Intermediate loading and unloading areas where located in tandem to permit simultaneous loading and unloading at an intermediate point in the system shall be separated by an adequate distance which permits the exit of the unloading passenger and the reloading of the vacated carrier. In no case may the distance, in feet, from the unloading point to the loading point be less than 8 times the maximum rope speed in feet per second.

(4) CARRIER CONTROL. Carriers passing loading and unloading areas shall not vary in height above the area greater than 4 inches under the most adverse conditions of design loadings and rope tensions.

History: Cr. Register, June, 1984, No. 342, eff. 7-1-84.

ILHR 33.44 Towers. (1) TOWER IDENTIFICATION. All towers of an aerial lift shall be identified with successive numbers.

(2) TOWER GUARDS AND CLEARANCES. (a) *Guards.* Except as permitted in par. (c), all towers of an aerial lift shall be equipped with guards to prevent the contact of any part of the carrier with a tower or tower machinery and to maintain the minimum clearances specified in par. (b).

1. Carriers shall be capable of swinging 8° laterally before engaging a guard or encroaching upon the clearance specified in par. (b).

2. Guards shall be so shaped and located that a 30° lateral swing from the vertical will not place any part of a carrier on the inner side of the guard.

(b) *Clearances.* A carrier swung laterally 8° from a vertical position shall maintain the following minimum clearances with the tower:

1. Twelve inches between the innermost point on a carrier of a chairlift and the tower clearance line or surface; and

Register, June, 1984, No. 342

2. Eighteen inches between the innermost point of a gondola lift with open windows on the tower side and the tower clearance line or surface.

(c) *Exceptions.* The requirements of pars. (a) and (b) are inapplicable, if contact with a tower or tower machinery does not occur where a carrier is swung 15° from the vertical position.

(3) **TOWER GUYS.** Where the tower guys of an aerial lift intersect the ground within or near ski runs, the guys shall be marked for visibility, with boards painted with black and yellow stripes or other approved means. Painted boards shall be at least 8 inches in nominal width and shall extend at least 8 feet in length above the surface of the snow.

(4) **SKI TIP DEFLECTORS.** Ski tip deflectors shall be provided as specified in this subsection in order to prevent the entanglement of skis with the tower structures of a chairlift.

(a) With the carrier swinging in laterally 10° from the vertical position, or to the limit permitted by the tower guards, if the clearance is less than 24 inches from any open frame tower or 18 inches from any closed tubular tower, tip deflectors to keep skis from being caught in the structure shall be provided on each side where passengers wearing skis are allowed. For the purpose of this provision, clearance shall mean the distance between the inner limit of the passenger seat and the clearance line or surface of the tower.

(b) Tip deflectors shall be at least 72 inches in height, extending at least 18 inches above and at least 54 inches below the carrier seat.

(c) A tubular tower with permanent ladder rungs shall be considered as an open frame tower, unless ski tips cannot be caught in the ladder.

History: Cr. Register, June, 1984, No. 342, eff. 7-1-84.

ILHR 33.45 Carrier speeds. (1) AERIAL LIFTS WITH DETACHABLE GRIPS. Haul rope speeds for aerial lifts with detachable grips shall not exceed 900 feet per minute.

(2) **AERIAL LIFTS WITH FIXED GRIPS.** Except as provided in pars. (a) and (b), carriers for aerial lifts with fixed grips shall not exceed the speed limits specified in Table 33.45.

Table 33.45
 Maximum Carrier Speeds For
 Aerial Lifts With Fixed Grips
 (in feet per minute)

Single Chair	Double Chair	Triple Chair	Other Chairs
600	550	500	450

(a) Carriers of an aerial lift which is stopped for the purposes of loading and unloading shall not exceed a speed of 700 feet per minute.

Register, June, 1984, No. 342

(b) Carriers of an aerial lift which is not stopped for loading and unloading of foot passengers shall not exceed a speed of 175 feet per minute when the carriers are at the loading and unloading areas.

History: Cr. Register, June, 1984, No. 342, eff. 7-1-84.

ILHR 33.46 Manual and automatic stops. (1) **GENERAL.** (a) All electric control circuits for stop switches shall be energized circuits so that in the event of an electric power failure, the aerial lift shall be inoperative.

(b) An inadvertent ground shall cause an automatic stop switch to be activated.

(c) Where guillotine-type stop switches are used to sever wires in the emergency stop circuit upon a haul rope deropement from a sheave, solid-wire conductors shall be used.

(d) All stop switches, manual and automatic, shall be of the type which must be reset manually.

(e) When there is only one stop circuit, it shall be classified as the emergency stop circuit.

(f) Interruption of the emergency stop circuit shall disengage or stop the power unit of the aerial lift in use at the time.

(2) **MANUAL STOPS.** (a) All aerial lifts shall be provided with manual stop switches which will stop the system's power unit and activate the service brake.

(b) Manual stop switches shall be installed at the following locations:

1. At each loading and unloading area;
2. At the aerial lift's operating controls; and
3. At the aerial lift's power units.

(3) **AUTOMATIC STOPS.** (a) All aerial lifts shall be provided with automatic stop switches which will stop the system's power unit and activate the service brake.

(b) An automatic stop shall be activated:

1. When the haul rope leaves the groove of any terminal sheave;
2. Before a counterweight or tension sheave carriage reaches its limit of travel;
3. When a carrier's detachable grip does not engage properly to the haul rope at every grip attachment point; or
4. When a carrier's detachable grip does not disengage properly from the haul rope at every grip attachment point; and
5. In the event a carrier's passenger travels beyond the designated unloading area.

a. Where a hazard exists to passengers or equipment in the event a passenger enters or passes around a terminal, the automatic stop switch shall be so located that the distance from the stop switch to the first obstruction or the tangent of the bull wheel, whichever is less, is 150% of

Register, June, 1984, No. 342

the distance required to stop with the aerial lift operating at maximum speed under the most unfavorable unloading condition.

b. Where no hazard exists to passengers or equipment in the event a passenger enters or passes around a terminal, the automatic stop switch shall be so located that the aerial lift is stopped before the passenger passes beyond an unloading area on the opposite side of the lift from the designated unloading area and adjacent to the terminal, under conditions of maximum speed under the most unfavorable unloading condition.

History: Cr. Register, June, 1984, No. 342, eff. 7-1-84.

ILHR 33.47 System operations. (1) **PERSONNEL.** Each aerial lift shall have at least one attendant present at each loading area and unloading area.

(a) The duties of the attendants at the loading and unloading areas shall include observing for any potentially dangerous operational or mechanical developments within their view.

(b) Each attendant shall have controls to stop the aerial lift readily available and shall maintain an operating position no more than 10 feet from these controls.

(c) An aerial lift shall be stopped whenever a required attendant is further than 10 feet from the controls to stop the system.

(2) **OPERATIONAL REQUIREMENTS.** After any stop, an aerial lift shall not be started until the cause of the stop is determined and clearance has been obtained from all of the system's attendants.

History: Cr. Register, June, 1984, No. 342, eff. 7-1-84.

ILHR 33.48 Signs. (1) **INFORMATION.** Chairlifts shall be posted with signs at appropriate locations indicating the information specified in pars. (a) to (g).

(a) The removal of pole straps at loading areas.

(b) Advance notice of the unloading area at least 50 feet before its location.

(c) Keeping ski tips up ahead of any point where skis may come in contact with an unloading platform or the snow surface.

(d) The designated unloading area.

(e) After unloading, to ski away and under control.

(f) To remain in the carriers until reaching the unloading areas.

(g) The location of the safety gate and how to actuate the safety gate in order to stop the lift.

(2) **VISIBILITY.** The signs specified in sub. (1) shall be visible during normal operating periods.

History: Cr. Register, June, 1984, No. 342, eff. 7-1-84.

SUBCHAPTER VI
SURFACE LIFT SYSTEMS

ILHR 33.60 Application. The requirements of this subchapter shall apply to all surface lifts.

History: Cr. Register, June, 1984, No. 342, eff. 7-1-84.

ILHR 33.61 Design requirements. All surface lifts shall be so designed and constructed that the maximum loads will not stress any part of a system beyond allowable limits.

(1) **POWER UNITS.** The power unit for a surface lift shall have the capability of handling the system's most unfavorable design loading conditions, including the starting of a fully loaded surface lift.

(2) **BRAKES.** (a) *Service brake.* Unless an unloaded surface lift operating at maximum speed is capable of stopping within a distance of 25 feet or a distance equal to the equation $d = V^2/18,000$, where d is the stopping distance in feet and V is the system's speed in feet per minute, whichever is greater, a service brake shall be provided which is capable of stopping a surface lift within this stopping distance.

1. A service brake shall be applied by springs or weights, except where another approved type of fail-safe brake is to be installed.

2. The service brake shall be applied to a drive shaft so that there is no clutch, or similar device between the brake and the drive sheave.

3. If the power unit for a surface lift is an internal combustion engine, the compression of the engine shall not serve as the service brake.

(b) *Backstop brake.* Every surface lift shall be provided with a backstop brake to automatically prevent reverse rotation of the system. The backstop brake shall be independent of the surface lift's power unit.

(3) **SPEED REDUCERS AND GEARING.** (a) All speed reducers and gearing shall have capacity for starting and operating a surface lift under the most unfavorable design loading conditions, and shall comply with s. ILHR 33.21 (3).

(b) Where reverse capability is provided on the power unit of a surface lift, provisions shall be made to prevent accidentally shifting into reverse whenever the system is operating.

(4) **SHEAVES.** (a) *General.* 1. All sheaves, including the mountings and frames, shall be designed to withstand all static and dynamic loads.

2. Unlined sheaves for wire ropes shall have grooves with V-shaped cross-sections and shall have rounded bottoms with a radius not less than 55% of the rope diameter.

3. For the purpose of this subsection, the diameter of a sheave shall be measured from the bottom of the sheave's grooves.

(b) *Terminal and deflection sheaves.* 1. Frames for terminal and deflection sheaves shall be designed to retain the rope in the event of sheave, shaft or mounting failure.

Register, June, 1984, No. 342

2. a. The minimum diameter for terminal sheaves and deflection sheaves shall be at least 72 times the nominal diameter of the haul rope, provided that no gripping device passes around the sheaves.

b. The minimum diameter for terminal sheaves and deflection sheaves shall be at least 80 times the nominal diameter of the haul rope where gripping devices pass around the sheaves.

3. Terminal sheave assemblies and deflection sheave assemblies shall be designed to retain the haul rope in the event of a deropement from the sheave.

4. Terminal sheaves and deflection sheaves shall be designed so that the haul rope does not slip in the sheave groove.

(c) *Counterweight rope sheaves.* The minimum diameter for counterweight sheaves shall be as specified in Table 33.61.

Table 33.61
Minimum Diameters for Counterweight
Rope Sheaves

Rope Classification	Sheave Diameter	
	Condition B ¹	Condition C ²
6 x 7	42d	24d
6 x 19	30d	20d
6 x 37	18d	12d

Note #1: Condition B is applicable where bending over sheaves is important, but some sacrifice in rope life is acceptable to achieve reduction in weight, economy in design or other purposes.

Note #2: Condition C is applicable to sheaves that are not intended to rotate due to any tension sheave movement but are intended to rotate only due to counterweight adjustment.

Note #3: "d" equals the nominal counterweight rope diameter.

(d) *Haul rope sheaves and mounts.* Sheaves which support or hold down the haul rope shall comply with the requirements of this paragraph.

1. The diameter of a haul rope sheave shall not be less than 10 times the nominal diameter of the haul rope for metallic sheaves or 8 times for sheaves with elastomer liners.

2. The design and construction of a haul rope sheave assembly shall be such that the haul rope cannot become entangled in the sheave assembly in the event the haul rope leaves the sheave away from a tower.

3. On hold-down sheave assemblies, rope-catching devices shall be installed to prevent the haul rope from moving upward in the event of deropement.

4. On support sheave assemblies, rope-catching devices shall be installed to prevent the haul rope from falling in the event of deropement. Rope-catching devices shall extend a minimum of 2 haul rope diameters beyond the sheave flange and be located less than one sheave diameter above or below the normal operating position of the rope.

5. Each haul rope sheave assembly shall be provided with devices which will stop the surface lift in case of deropement.

6. Sheave mounts or mounting frames shall be designed to be adjustable, allowing the sheave assemblies to be aligned and held in the plane of the rope.

7. Provisions shall be made to retain the haul rope in the sheave grooves under all loading conditions.

(5) COUNTERWEIGHT AND TENSIONING SYSTEMS. A counterweight or other devices shall be provided to determine and regulate the tension of the haul rope.

(a) *Design*. 1. A counterweight, where used, shall be arranged to move freely up and down.

2. Where a counterweight is contained in a structural frame, guides shall be provided to protect the frame, and to ensure free movement of the counterweight.

3. The counterweight, or other approved device, shall have sufficient travel to take care of all normal operating changes in loading and temperature.

(b) *Enclosures*. Guardrails or enclosures shall be provided to prevent persons from coming in contact with or passing under counterweights.

(c) *Winches*. 1. Winches which are used for a counterweight system's take-up and remain a permanent part of that system, shall have a minimum factor of safety of 6 relative to the ultimate capacity. Where this factor of safety cannot be established by manufacturer's endorsement, a safety device shall be installed on the counterweight rope ahead of the winch that will keep the tensioning system intact in the event of failure or release of the winch.

2. Winches shall have a positive lock against release.

(6) HAUL ROPES. (a) *Factor of safety*. Haul ropes, when new, shall have a minimum static factor of safety of 5.

(b) *Splices*. 1. The minimum length of a splice for a haul rope shall be 1200 times the nominal rope diameter.

2. The tails of the haul rope strands tucked into the core of the rope on splicing, shall be a minimum of 30 times the nominal rope diameter in length.

3. Where 2 or more splices occur in a haul rope, the splices shall be separated by an undisturbed length of rope which equals a minimum of 2400 times the nominal rope diameter.

(c) *Lubrication*. Substances used to lubricate a haul rope shall be of a type which will not adversely affect a sheave or sheave liner.

(7) COUNTERWEIGHT ROPES. (a) *Factor of safety*. Counterweight ropes, when new, shall have a minimum factor of safety of 6. The factor of safety shall be equal to the nominal breaking strength of the rope divided by the maximum static design tension.

(b) *Adjustment.* Counterweight ropes shall be adjusted so that the counterweight will reach the end of its travel before the attached tension sheave carriage comes within 6 inches of the end of its travel.

(c) *Splices.* Splices in counterweight ropes shall be prohibited.

(d) *End connections.* 1. End connections shall not fail or slip under a tension equal to 80% of the strength of the rope.

2. Sections of counterweight rope permanently deformed or damaged by the application of wire rope clips, or bent around thimbles, sheaves, or other anchoring devices not meeting the minimum diameters specified in ANSI B77.1, section 7, shall not be relocated or reused as a part of the section under load.

(e) *Metallic core.* Counterweight ropes shall have metallic cores.

(8) HAUL ROPE GRIPS. (a) *Design.* 1. Haul rope grips shall be designed to pass smoothly over and under those sheaves which have flanges of adequate depth to prevent the haul rope from leaving the sheaves.

2. The design of a haul rope grip shall incorporate provisions to accommodate a 10% reduction in haul rope diameter.

(b) *Slippage.* 1. A haul rope grip shall be designed and maintained during its use so as to resist a force, which tends to slide it along the haul rope, which is a minimum of 3 times the force required to move a carrier along a properly lubricated haul rope at the steepest incline under the most adverse conditions of carrier loading.

2. A haul rope grip shall automatically adjust to maintain its gripping force with a 3% reduction in haul rope diameter.

3. A haul rope grip shall not be located closer than 3 feet to the tail of a haul rope or to the rope tuck of a splice.

(c) *Strength.* The strength of a haul rope grip shall be based upon the criteria specified in subs. 1. to 5.

1. All parts of a haul rope grip subject to a stress which is proportional to the dead load and live load of a carrier shall have a minimum factor of safety of 6.

2. Those parts of a grip whose stress is not changed by the application of a live load shall be designed on the basis of an allowable stress of not more than the yield point divided by 3.0. In the design of springs, where used, the allowable stress may be increased if load tests are conducted by an approved testing laboratory to provide assurances that the fatigue life of the actual spring is more than ample for the various applied loads.

3. Grips subject to stresses caused by horizontal loads, such as centrifugal loads that stress the grips as they pass around the drive sheaves or return sheaves, shall be designed with a minimum factor of safety of 3.6 with respect to the yield point of the material.

4. The material of which the grip is made shall be selected or selected and treated to obtain optimum impact resistance.

5. Grips made up of cast parts shall be proof-loaded with forces equal to the gripping force plus 3 times the sum of the dead load plus the design live load.

(d) *Maximum loads.* The maximum total vertical load on a haul rope grip shall not exceed 1/14 of the minimum tension in the haul rope.

(e) *Detachable grips.* A detachable haul rope grip shall be designed and constructed in such a manner that it grips the haul rope positively without damaging the haul rope and in such a manner that it cannot become accidentally uncoupled.

(f) *Incorrect attachment.* Approved devices shall be installed which will stop an aerial lift, if any detachable grip is incorrectly attached to haul rope.

(9) **CARRIERS.** (a) *Loads.* Surface lift carriers shall be designed to support a vertical load at least 4 times the design load without permanent deformations of the carrier assembly or component parts.

(b) *General.* The bar, platter, or other device in contact with the skier shall be so designed that the passenger can embark and disembark. Devices which envelop the passenger, such as a strap, shall be prohibited.

(c) *Retractable towing outfits.* Retraction of a towing outfit shall be so controlled that it may be released from a fully extended position without causing such violent oscillations as to expose any part of the towing outfit to entanglement with the haul rope, sheaves, other structures, or equipment.

History: Cr. Register, June, 1984, No. 342, eff. 7-1-84.

ILHR 33.62 System location and clearances. (1) **SYSTEM'S PATH.** (a) Trees or vegetation shall be cleared so as not to interfere with the operation or function of the surface lift.

(b) The maximum permissible grade for the ski track of a surface lift's path shall be 100% for systems using single passenger carriers, and 80% for lifts using carriers for more than one passenger.

(c) No reverse grades may be permitted in the ski track of a surface lift's path.

(d) The cross slope of the ski track for a surface lift's path shall not exceed 5%.

(e) 1. The surface lift's path shall be cleared and maintained in such a manner that no rocks, stumps, or other obstructions project above the snow surface from the point where the passenger embarks on the lift to a point beyond the safety gate where the passenger would stop if the passenger failed to disembark and the safety gate was actuated.

2. The minimum snow track width for a surface lift's path shall be at least 2 feet 6 inches times the design number of passengers per carrier, but not less than 6 feet.

(2) **VERTICAL CLEARANCES.** (a) The haul rope of a surface lift shall be positioned high enough to clear a passenger's head by at least 2 feet, and keep down-coming, empty carriers clear of the snow.

(b) The down-coming, empty carrier of a surface lift shall clear a passenger's head by at least 2 feet at any area where skiers cross the path of the carriers.

Register, June, 1984, No. 342

(3) LOCATION. (a) Unless approved by the department, a surface lift shall not be located under:

1. Terrain features, such as cliffs and overhangs;
2. Bridges; and
3. Buildings and structures, other than at loading and unloading areas.

(b) 1. Unless approved by the department, a surface lift shall not be located under electrical lines greater than 50 volts.

2. Surface lift systems and electrical power lines of greater than 50 volts shall be separated by a distance such that:

a. Passengers cannot come in contact with the electrical lines; or

b. If the electrical lines break or collapse, the lines will not come into contact with any part of the lift system.

History: Cr. Register, June, 1984, No. 342, eff. 7-1-84.

ILHR 33.63 Loading and unloading areas. (1) LOADING AREAS. (a) *General*. Loading areas shall be of sufficient length and grade to permit the passenger to embark onto the carriers of the surface lift.

(b) *Minimum dimensions and grades*. 1. The loading area shall be at least 8 feet in length, centered on the designated loading spot for the carriers, and shall be at least 4 feet in width.

2. The loading area shall have a maximum slope of 2%, in the carrier's line of travel, and a maximum cross slope of 5%.

(2) UNLOADING AREAS. Unloading areas shall be of sufficient length and grade to permit the disembarking passenger to leave the carrier.

(a) The unloading area shall have a minimum slope of 2% downward in the direction of the carrier's line of travel from the top breakover sheave to the unloading area's safety gate.

(b) The distance between unloading area and upper terminal guides shall be of sufficient length to allow towing outfits to become retracted and to permit their oscillations to diminish adequately before entering the terminal.

History: Cr. Register, June, 1984, No. 342, eff. 7-1-84.

ILHR 33.64 Towers. (1) TOWER IDENTIFICATION. All towers of a surface lift shall be identified with successive numbers.

(2) TOWER GUYS. Where tower guys of a surface lift intersect the ground within or near ski runs, the guys shall be marked for visibility, with boards painted with black and yellow stripes or other approved means. Painted boards shall be at least 8 inches in nominal width and shall extend at least 8 feet in length above the surface of the snow.

History: Cr. Register, June, 1984, No. 342, eff. 7-1-84.

ILHR 33.65 Carrier speeds. (1) SINGLE PASSENGER CARRIERS. Surface lift carriers designed to accommodate a single passenger shall not exceed speeds which maintain at least a minimum loading interval of 3 seconds plus the time required to extend the carriers to a point where the passenger begins to move uphill.

Register, June, 1984, No. 342

(2) **MULTIPLE PASSENGER CARRIERS.** Surface lift carriers designed to accommodate more than a single passenger shall not exceed speeds that maintain at least a minimum loading interval of 4 seconds plus the time required to extend the carrier to such a point that the passenger begins to move uphill.

History: Cr. Register, June, 1984, No. 342, eff. 7-1-84.

ILHR 33.66 Manual and automatic stops. (1) **GENERAL.** (a) All electric control circuits for stop switches shall be energized circuits so that in the event of electric power failure, the surface lift shall be inoperative.

(b) An inadvertent ground shall cause an automatic stop to be activated.

(c) Where guillotine-type stop switches are used to sever wires in the emergency stop circuits upon a haul rope deropement from a sheave, solid-wire conductors shall be used.

(d) All stop switches, manual and automatic, shall be of a type which must be reset manually.

(e) When there is only one stop circuit, it shall be classified as the emergency stop circuit.

(f) Interruption of the emergency stop circuit shall disengage or stop the power unit of the surface lift.

(2) **MANUAL STOPS.** (a) All surface lifts shall be provided with manual stop switches which will stop the system's power unit and activate the service brake.

(b) Manual stop switches shall be installed at the following locations:

1. At each loading and unloading area;
2. At the surface lift's operating controls; and
3. At the surface lift system's power unit.

(3) **AUTOMATIC STOPS.** (a) All surface lifts shall be provided with automatic stop switches which will stop the system's power unit and activate the service brake.

(b) An automatic stop switch shall be activated:

1. Before a counterweight or tension sheave carriage reaches its limit of travel; or

2. In the event a carrier's passenger travels beyond the designated point of unloading. The stop switch shall be so located that the distance from the stop switch to the first obstruction or point of reversal of direction of the towing outfits is 150% of the distance required to stop an empty surface lift operating at maximum speed.

History: Cr. Register, June, 1984, No. 342, eff. 7-1-84.

ILHR 33.67 System operations. (1) **PERSONNEL.** Each surface lift shall have at least one attendant present at each loading area and unloading area.

Register, June, 1984, No. 342.

(a) The duties of the attendants at the loading and unloading areas shall include observing for any potentially dangerous operational or mechanical developments within their view.

(b) Each required attendant shall have controls to stop the surface lift readily available and shall maintain an operating position not more than 10 feet from these controls.

(c) A surface lift shall be stopped whenever a required attendant is further than 10 feet from the controls to stop the system.

(2) OPERATIONAL REQUIREMENTS. After any stop, a surface lift shall not be started until the cause of the stop has been determined and clearance has been obtained from all of the system's attendants.

History: Cr. Register, June, 1984, No. 342, eff. 7-1-84.

ILHR 33.68 Signs. (1) INFORMATION. Surface lift systems shall be posted with signs at appropriate locations indicating the information specified in pars. (a) to (g).

(a) The removal of pole straps from wrists before loading.

(b) To stay in the ski track of the surface lift's path when riding the lift.

(c) Advance notice of the unloading area at least 50 feet before its location.

(d) The designated unloading area.

(e) Release carrier gently when unloading.

(f) After unloading, to ski away and under control.

(g) The location of the safety gate and how to actuate the safety gate in order to stop the lift.

(2) VISIBILITY. The signs specified in sub. (1) shall be visible during normal operating periods.

History: Cr. Register, June, 1984, No. 342, eff. 7-1-84.

SUBCHAPTER VII ROPE TOW SYSTEMS

ILHR 33.80 Application. The requirements of this subchapter shall apply to all rope tow systems.

History: Cr. Register, June, 1984, No. 342, eff. 7-1-84.

ILHR 33.81 Design requirements. All rope tows shall be so designed and constructed that the maximum loads will not stress any part of a system beyond allowable limits.

(1) POWER UNIT. (a) The power unit for a rope tow shall have capacity to handle the most unfavorable design loading conditions, including the starting of a fully loaded rope tow.

(b) Where manual multispeed transmissions are used on the power unit, gears shall not be shifted when the rope tow system is moving.

Register, June, 1984, No. 342

(c) Where the power unit of a rope tow has reverse capabilities, provisions shall also be made to prevent accidentally shifting into reverse whenever the system is operating.

(2) BRAKES. (a) *Service brake*. Unless an unloaded rope tow operating at maximum speed is capable of stopping within a distance of 25 feet, a service brake shall be provided which is capable of stopping the rope tow within this stopping distance.

1. The service brake shall be applied by springs or weights, except where another approved type of fail-safe brake is to be installed.

2. The service brake shall be applied to a drive shaft so that there is no clutch, or similar device between the brake and the drive sheave.

3. The service brake shall be applied when any stop circuit is interrupted.

4. If the power unit for a rope tow is an internal combustion engine, the compression of the engine shall not serve as the service brake.

(b) *Backstop brake*. 1. Every rope tow with an average grade in excess of 15% shall be provided with a backstop brake to prevent reverse rotation of the system, unless the tow will not roll back under the most adverse loading.

2. The service brake may serve as the backstop brake where a tow will not roll back under the most adverse loading.

(3) SHEAVES. (a) *General*. 1. All sheaves, including the mountings and frames, shall be designed to withstand all static and dynamic loads.

2. Unlined sheaves for wire ropes shall have grooves with V-shaped cross-sections and shall have rounded bottoms with a radius not less than 55% of the rope diameter.

3. For the purpose of this subsection, the diameter of a sheave shall be measured from the bottom of the sheave's grooves.

(b) *Terminal sheaves and deflection sheaves*. 1. Terminal and deflection sheave frames shall be designed to retain the haul rope in the event of sheave, shaft or mounting failure.

2. a. The minimum diameter for terminal sheaves and deflection sheaves for wire ropes shall be at least 72 times the nominal diameter of the haul rope, provided that no gripping device passes around the sheave.

b. The minimum diameter for terminal sheaves and deflection sheaves for wire ropes shall be at least 80 times the nominal diameter of the haul rope in cases where gripping devices pass around the sheave.

3. Terminal sheave assemblies and deflection sheave assemblies shall be designed to retain the haul rope in the event of a deropement from the sheave.

4. Terminal and deflection sheaves shall be designed so that the haul rope does not slip in the sheave groove.

5. Return rope sheaves for fiber ropes shall be mounted high enough on intermediate towers to hold the haul rope at least 7 feet above the snow surface of the rope tow path.

(4) TENSIONING SYSTEMS. (a) *Wire rope tows.* Wire rope tow systems shall be provided with an approved mechanical or hydraulic tensioning system that will ensure that the haul rope tension does not exceed a value of one-fifth its nominal breaking strength under the most unfavorable accumulation of stress due to loading, operating, temperature, and like considerations.

(b) *Fiber rope tows.* An approved counterweight system or other approved tensioning device shall be provided for all fiber rope tow systems.

(5) HAUL ROPES. (a) *Wire haul ropes.* 1. Factor of safety. Wire haul ropes shall have a minimum static factor of safety of 5 when new.

2. Splices. a. Except as provided in subpar. d., the minimum length of a splice for a wire haul rope shall be 1200 times the nominal rope diameter.

b. The tails, or lengths of the wire haul rope strands tucked into the core of the rope on splicing, shall be a minimum of 30 times the nominal rope diameter in length.

c. Where 2 or more splices occur in a wire haul rope, the splices shall be separated by an undisturbed length of rope which equals a minimum of 2400 times the nominal rope diameter.

d. Sleeve-type splices or wedge-splice handles may be provided in wire rope tows. These types of splices shall be replaced annually.

(b) *Fiber haul ropes.* 1. Fiber haul ropes shall have minimum factor of safety of 5 based upon the breaking strength of the new rope divided by the maximum full-load static tension in the haul rope.

2. Sheave adjustment or other approved means shall be provided to regulate rotation of the up-going haul rope of a fiber rope tow, limiting spiraling to no more than one complete revolution in 200 feet of travel and not to exceed 3 revolutions in the total uphill length of any tow. This spiraling measurement shall be taken with no one using the rope tow system.

(6) COUNTERWEIGHT ROPES. (a) *Factor of safety.* Counterweight ropes, when new, shall have a minimum factor of safety of 6. The factor of safety shall be equal to the nominal breaking strength of the rope divided by the maximum static design tension.

(b) *Adjustment.* Counterweight ropes shall be adjusted so that the counterweight will reach the end of its travel before the attached tension sheave carriage comes within 6 inches of the end of its travel.

(c) *Splices.* Splices in counterweight ropes shall be prohibited.

(d) *End connections.* 1. End connections shall not fail or slip under a tension equal to 80% of the strength of the rope.

2. Sections of wire counterweight rope permanently deformed or damaged by the application of wire rope clips, or bent around thimbles, sheaves, or other anchoring devices not meeting the minimum diameters specified in ANSI B77.1, section 7, shall not be relocated or reused as a part of the section under load.

ILHR 33

(e) *Metallic core.* Counterweight ropes shall have metallic cores.

(7) CARRIERS. (a) *Wire rope tows.* Wire rope tows shall be provided with fixed towing handles.

1. Towing handles on wire rope tows shall be designed to prevent sliding along the haul rope when subject to twice the force required to move a passenger along the tow path at the steepest point.

2. Towing handles shall be designed to preclude entangling gloves or clothing, or pinching fingers between the handles and the wire haul rope.

3. The attachment of towing handles shall not impair the strength of the wire haul rope.

4. Towing handles shall be relocated on a wire haul rope at least once a year.

(b) *Fiber rope tows.* Towing outfits, handles or rope grippers shall not be attached to fiber rope tows.

History: Cr. Register, June, 1984, No. 342, eff. 7-1-84.

ILHR 33.82 Tow path, clearances and location. (1) TOW PATH. (a) Reverse grades shall not be permitted in the ski track of a rope tow's path except for very gradual inclines at loading and unloading areas.

(b) 1. The cross slope for the ski track of a rope tow path shall not exceed 5% except at unloading areas.

2. The cross slope for the ski track of a wire rope tow's path shall be away from the system's haul rope.

(c) The rope tow's path shall have a minimum snow track width of 3 feet on each side of the centerline of the uphill haul rope that shall be cleared and maintained in such a manner that no rocks, stumps, or other obstructions project above the snow surface from the point where a person embarks on the tow to the point beyond the safety gate where the passenger would stop. For the purpose of this requirement, the centerline of the uphill haul rope shall be determined by a straight line from the loading terminal sheave to the first sheave after the safety gate.

(2) CLEARANCES. (a) Trees and vegetation shall be cleared so as not to interfere with the operation or function of the rope tow.

(b) At no point between the loading and unloading areas may the haul rope exert a downward force greater than 35 pounds, or an upward force greater than 30 pounds, when held at a height of 2 feet above the snow surface by a single passenger.

(c) Towing devices on wire rope tow systems shall not contact the ground or snow surface at any point along the system.

(d) Where the downhill haul rope is less than 7 feet above the ski track, protective fencing, or other approved means, shall be provided to prevent persons from coming in contact with the downhill haul rope.

(e) The distance between the uphill and downhill haul rope of a wire rope tow shall, at all points, exceed twice the projection of any towing device attached to the haul rope.

Register, June, 1984, No. 342

(3) **LOCATION.** (a) Unless approved by the department, a wire rope tow system shall not be located under electrical power lines greater than 50 volts.

(b) Wire rope tow systems and electrical power lines of greater than 50 volts shall be separated by a distance such that:

1. Passengers cannot come in contact with the electrical lines; or
2. If the electrical lines break or collapse, the lines will not come into contact with any part of the tow system.

History: Cr. Register, June, 1984, No. 342, eff. 7-1-84.

ILHR 33.83 Loading and unloading areas. (1) **LOADING.** Loading areas shall be level or nearly level. The area shall be free of obstructions and fenced in a manner to guide passengers to the loading point.

(2) **UNLOADING.** Unloading areas shall be nearly level or graded to form a ramp inclined downward in the direction of travel and outward from the line of the uphill haul rope to provide movement away from the tow.

History: Cr. Register, June, 1984, No. 342, eff. 7-1-84.

ILHR 33.84 Towers. (1) **TOWER IDENTIFICATION.** All towers of a rope tow system shall be identified with successive numbers.

(2) **TOWER GUYS.** Where tower guys of a rope tow intersect the ground within or near ski runs, the guys shall be marked for visibility with boards painted with black and yellow stripes or other approved means. Painted boards shall be at least 8 inches in nominal width and shall extend at least 8 feet in length above the surface of the snow.

History: Cr. Register, June, 1984, No. 342, eff. 7-1-84.

ILHR 33.85 Haul rope speeds. (1) **WIRE ROPE TOWS.** The haul rope for wire rope tow systems shall not exceed a speed of 400 feet per minute.

(2) **FIBER ROPE TOWS.** The haul rope for fiber rope tow systems shall not exceed a speed of 1200 feet per minute.

History: Cr. Register, June, 1984, No. 342, eff. 7-1-84.

ILHR 33.86 Manual and automatic stops. (1) **GENERAL.** (a) All electric control circuits for stop switches shall be energized circuits so that in the event of an electric power failure, the rope tow shall be inoperative.

(b) An inadvertent ground shall cause an automatic stop to be activated.

(c) All stop switches, manual and automatic, shall be of a type which must be reset manually.

(d) When there is only one stop circuit, it shall be classified as the emergency stop circuit.

(e) Interruption of the emergency stop circuit shall disengage or stop the power unit of the rope tow.

(2) **MANUAL STOPS.** (a) All rope tows shall be provided with manual stop switches which will stop the system's power unit and activate the service brake.

Register, June, 1984, No. 342

(b) Manual stop switches shall be installed at the following locations:

1. At each loading and unloading area;
2. At the rope tow's operating control; and
3. At the rope tow's power unit.

(3) AUTOMATIC STOPS. (a) All tows shall be provided with automatic stop switches which will stop the system's power unit and activate the service brake.

(b) An automatic stop switch shall be actuated in the event a user of a rope tow travels beyond the designated point of unloading. This automatic stop switch shall conform to the provisions specified in subs. 1. to 4.

1. The stop switch shall be located so that a user cannot bypass the switch.

2. The stop switch shall be of the suspended type. The suspended portion of the switch shall be strong enough to cause activation of the switch under the most adverse conditions. Each end of the suspended portion shall be detachable and shall activate the stop switch.

3. The design and operation of the stop switch shall not pose a hazard to the user.

4. The automatic stop switch shall be so located that the distance from the stop switch to the first obstruction or point of reversal of direction of the towing outfits is 150% of the distance required to stop the empty tow operating at maximum speed.

History: Cr. Register, June, 1984, No. 342, eff. 7-1-84.

ILHR 33.87 System operations. (1) PERSONNEL. Except as provided in pars. (b) and (c), each rope tow shall have at least one attendant present at each loading area and unloading area.

(a) 1. The duties of the attendants at the loading and unloading areas shall include observing for any potentially dangerous operational or mechanical developments within their view.

2. Each attendant shall have controls to stop the rope tow readily available and shall maintain an operating position no more than 10 feet from these controls.

3. The rope tow shall be stopped whenever a required attendant is further than 10 feet from the controls to stop the rope tow system.

(b) A rope tow system may have only one attendant present at either the loading area or unloading area, if:

1. The rope tow system is less than 800 feet in length, measured from the loading area to the safety gate; and

2. The attendant is positioned so as to have an unobstructed view of the entire length of the system, either physically or through television surveillance; and

Register, June, 1984, No. 342

3. The attendant has controls to stop the rope tow system readily available and maintains an operating position no more than 10 feet from these controls; and

4. The tow system will be stopped whenever the required attendant is further than 10 feet from the controls to stop the rope tow system.

(c) One attendant may serve more than one rope tow loading area or unloading area, if:

1. The attendant is positioned so that all loading areas or unloading areas under their responsibility are within a 90 degree cone of vision; and

2. The attendant has controls to stop all rope tows readily available and maintains an operating position no more than 10 feet from these controls; and

3. The stopping controls are clearly marked to indicate the corresponding rope tow system; and

4. All tow systems under the attendant's responsibility will be stopped whenever the required attendant is further than 10 feet from the controls to stop the rope tow systems.

(2) OPERATIONAL REQUIREMENTS. After any stop, a rope tow shall not be restarted until the cause of the stop has been determined and clearance has been obtained from all attendants for that rope tow.

History: Cr. Register, June, 1984, No. 342, eff. 7-1-84.

ILHR 33.88 Signs. (1) INFORMATION. Rope tow systems shall be posted with signs at appropriate locations indicating the information specified in pars. (a) to (g).

(a) The removal of pole straps from wrists before loading.

(b) A warning for loose clothing or exposed hair at the loading area.

(c) To stay in the ski track of the rope tow's path when riding the tow.

(d) Advance notice of the unloading area at least 50 feet before its location.

(e) The designated unloading area.

(f) After unloading, to ski away and under control.

(g) The location of the safety gate and how to actuate the safety gate in order to stop the tow.

(2) VISIBILITY. The signs specified in sub. (1) shall be visible during normal operating periods.

History: Cr. Register, June, 1984, No. 342, eff. 7-1-84.

SUBCHAPTER VIII INCORPORATION OF STANDARDS BY REFERENCE

ILHR 33.90 Incorporation of standards by reference. (1) CONSENT. Pursuant to s. 227.025, Stats., the Attorney General and the Revisor of Stat-

Register, June, 1984, No. 342

utes have consented to the incorporation by reference of the standards adopted in sub. (4).

(2) COPIES. Copies of the adopted standards are on file in the offices of the department, the secretary of state and the revisor of statutes. Copies also may be purchased through the respective organizations.

(3) INTERIM AMENDMENTS. Interim amendments of the adopted standards shall have no effect in the state until such time as this section is correspondingly revised to reflect the changes.

(4) STANDARDS INCORPORATED. The standards specified in Tables 33.90-1, 33.90-2 and 33.90-3 are hereby incorporated by reference into this chapter.

Table 33.90-1

AGMA	American Gear Manufacturers Association Standards Department 1901 North Fort Meyer Drive Arlington, Virginia 22209
------	---

(a) Surface Durability (Pitting) Formulas for Straight Bevel and Zerol Bevel Gear Teeth, AGMA 212.02 - 1964;

(b) Rating the Pitting Resistance and Bending Strength of Spur and Helical Involute Gear Teeth, AGMA 218.01 - 1982;

(c) Rating the Strength of Straight Bevel and Zerol Bevel Gear Teeth, AGMA 222.02 - 1964;

(d) Practice for Enclosed Speed Reducers or Increases Using Spur, Helical, Herringbone and Spiral Bevel Gears, AGMA 420.04 - 1975;

(e) Practice for Gearmotors Using Spur, Helical, Herringbone and Spiral Bevel Gears, AGMA 460.05 - 1971; and

(f) Practice for Spur, Helical and Herringbone Gear Shaft-Mounted Speed Reducers, AGMA 480.06 - 1977.

Table 33.90-2

ANSI	American National Standards Institute, Inc. Sales Department 1430 Broadway New York, New York 10018
	Safety Requirements for Passenger Tramways, Aerial Tramways and Lifts, Surface Lifts, and Tows, ANSI B77.1, Section 7, Wire Rope and Strand Re- quirements, 1982

Table 33.90-3

NFPA	National Fire Protection Association Publications Sales Department Batterymarch Park Quincy, Massachusetts 02269
------	---

Standard for the Installation and Use of Stationary Combustion Engines and Gas Turbines, NFPA 37-1979.

History: Cr. Register, June, 1984, No. 342, eff. 7-1-84.

APPENDIX

The material contained in the Appendix is for clarification purposes only. The notes, illustrations, etc. are numbered to correspond to the number of the rule as it appears in the text of the code.

A-33.03 (1) PLAN SUBMITTALS. Plans for tows, lifts and tramways are to be submitted to the Bureau of Safety Inspection, Division of Safety and Buildings, P.O. Box 7969, 201 East Washington Avenue, Room 146, Madison, Wisconsin 53707.

A 33.08 FEES. The fees for plan examinations, inspections and certificates of operation are specified in s. Ind 69.13. The fees of s. Ind 69.13 are subject to change; contact the Bureau of Safety Inspection, P.O. Box 7969, 201 East Washington Avenue, Madison, Wisconsin 53707, for the current fees. On July 1, 1984, s. Ind 69.13 read as follows:

Ind 69.13 Ski lifts and towing devices. (1) PLAN EXAMINATION FEE. Fee for the examination of plans for ski lifts and towing devices shall be determined in accordance with Table 69.13-1.

Table 69.13-1

Type of Lift or Device	Fee Per Plan
Gondola lifts and rides.....	\$270.00
Chair lifts and rides.....	\$205.00
Surface tows, except fiber and wire rope tows	\$135.00
Fiber and wire rope tows	\$ 81.00

Note: See s. Ind 47.02 for definition of the term "Amusement Ride" as it applies to ski lift and towing devices used as amusement rides.

(2) INSPECTION FEES. Fees for the inspection of new installations, annual inspections and other inspections shall be determined in accordance with Table 69.13-2.

Note: See s. Ind 47.02 for definition of the term "Amusement Ride" as it applies to ski lift and towing devices used as amusement rides.

Table 69.13-2

Type of Lift of Device	Inspection Fee Per Installation
Gondola Lifts and rides	\$205.00
Chair lifts and rides.....	\$205.00
Surface tows, except fiber and wire rope tows	\$135.00
Fiber and wire rope tows	\$ 81.00

Note: Surface tows include T-bar, platter, and similar devices.

(3) LOAD TEST FEE. The fee for certifying a load test shall be \$135.00.

(4) CERTIFICATE OF OPERATION. The department shall issue a certificate of operation upon receipt of a \$16.00 fee for each device and the inspection report indicating the device satisfies the minimum operating standards specified in ch. Ind 46 [ch. ILHR 33]

A-33.43 (2) (b) Unloading Areas for Chairlifts.

Register, June, 1984, No. 342

A33.43(2)(b) UNLOADING AREAS FOR CHAIRLIFTS

Register, June, 1984, No. 842

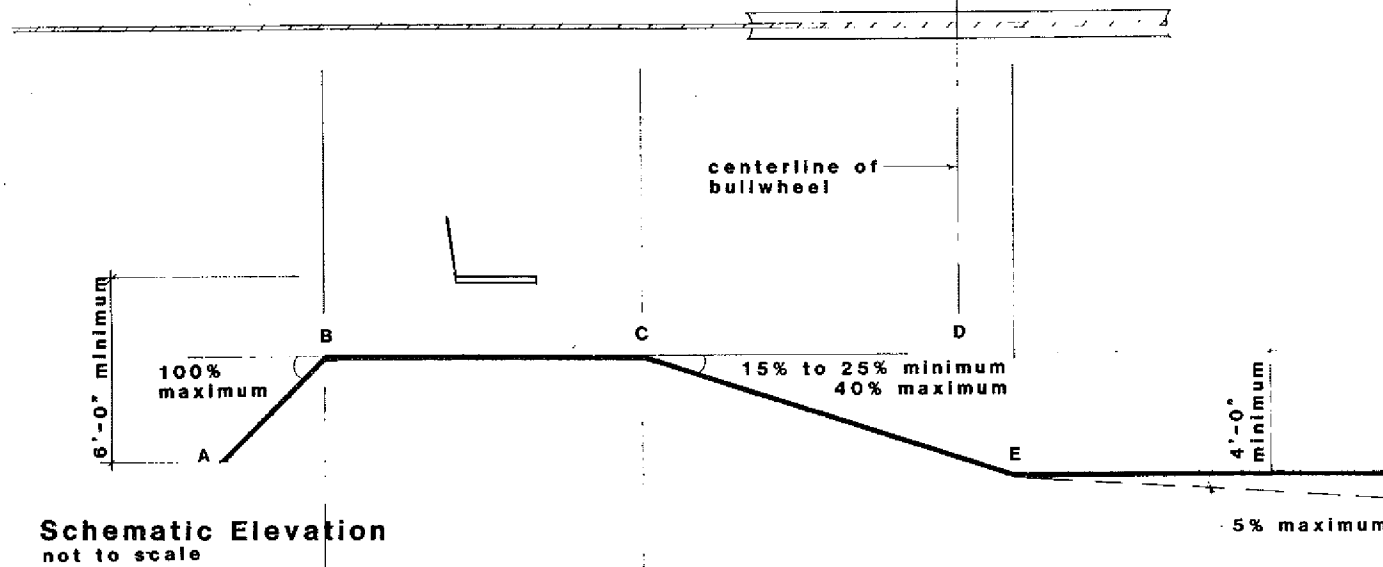
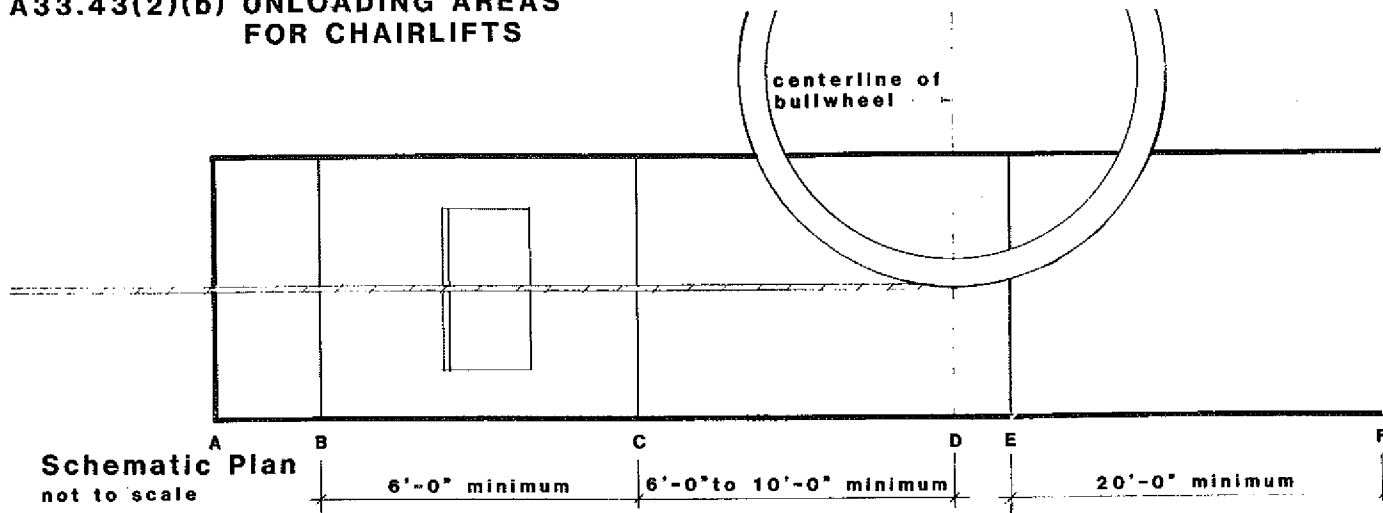

APPROACH RAMP	DISEMBARKING AREA	DISCHARGE RAMP	RUNOUT AREA
ILHR 33.43 (2) (b) 2. maximum downward pitch - 100% minimum vertical distance between points "A" and "B" - 6 feet	ILHR 33.43 (2) (b) 1. minimum length - 6 feet minimum width - 2 feet wider than carrier	ILHR 33.43 (2) (b) 3, 5 & 4. maximum slope - 40% minimum vertical distance between points "C" and "E" - 4 feet ILHR 33.43 (2) (b) 5, 6 & 6. minimum slopes: 15% for maximum carrier speed of 350 fpm 20% for maximum carrier speed of 450 fpm 25% for maximum carrier speed of over 450 fpm bullwheel unloading: minimum distance between points "C" and "D": 6 feet for maximum carrier speed of 350 fpm 8 feet for maximum carrier speed of 450 fpm 10 feet for maximum carrier speed of over 450 fpm	ILHR 33.43 (2) (b) 7. minimum length - 20 feet maximum downward slope - 5%